

AD

TECHNICAL REPORT ARCCB-TR-95029

THE RELATIONSHIP BETWEEN RESIDUAL STRESS AND HARDNESS AND THE ONSET OF PLASTIC DEFORMATION

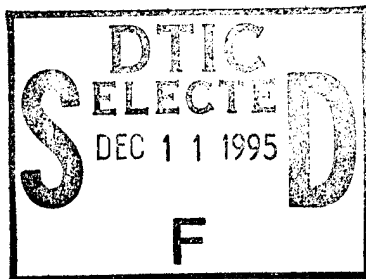

S.C. SCHROEDER
J. FRANKEL
A. ABBATE

MAY 1995



US ARMY ARMAMENT RESEARCH,
DEVELOPMENT AND ENGINEERING CENTER
CLOSE COMBAT ARMAMENTS CENTER
BENÉT LABORATORIES
WATERVLIET, N.Y. 12189-4050



APPROVED FOR PUBLIC RELEASE; DISTRIBUTION UNLIMITED

19951208 032

DTIC QUALITY INSPECTED A

DISCLAIMER

The findings in this report are not to be construed as an official Department of the Army position unless so designated by other authorized documents.

The use of trade name(s) and/or manufacturer(s) does not constitute an official indorsement or approval.

DESTRUCTION NOTICE

For classified documents, follow the procedures in DoD 5200.22-M, Industrial Security Manual, Section II-19 or DoD 5200.1-R, Information Security Program Regulation, Chapter IX.

For unclassified, limited documents, destroy by any method that will prevent disclosure of contents or reconstruction of the document.

For unclassified, unlimited documents, destroy when the report is no longer needed. Do not return it to the originator.

REPORT DOCUMENTATION PAGE

Form Approved
OMB No. 0704-0188

Public reporting burden for this collection of information is estimated to average 1 hour per response, including the time for reviewing instructions, searching existing data sources, gathering and maintaining the data needed, and completing and reviewing the collection of information. Send comments regarding this burden estimate or any other aspect of this collection of information, including suggestions for reducing this burden, to Washington Headquarters Services, Directorate for Information Operations and Reports, 1215 Jefferson Davis Highway, Suite 1204, Arlington, VA 22202-4302, and to the Office of Management and Budget, Paperwork Reduction Project (0704-0188), Washington, DC 20503

1. AGENCY USE ONLY (Leave blank)		2. REPORT DATE May 1995	3. REPORT TYPE AND DATES COVERED Final	
4. TITLE AND SUBTITLE THE RELATIONSHIP BETWEEN RESIDUAL STRESS AND HARDNESS AND THE ONSET OF PLASTIC DEFORMATION			5. FUNDING NUMBERS AMCMS: 6126.24.H180.0 PRON: LT4B4FVQ1ABJ	
6. AUTHOR(S) S.C. Schroeder (Benét Laboratories and RPI, Troy, NY), J. Frankel, A. Abbate				
7. PERFORMING ORGANIZATION NAME(S) AND ADDRESS(ES) U.S. Army ARDEC Benét Laboratories, AMSTA-AR-CCB-O Watervliet, NY 12189-4050			8. PERFORMING ORGANIZATION REPORT NUMBER ARCCB-TR-95029	
9. SPONSORING / MONITORING AGENCY NAME(S) AND ADDRESS(ES) U.S. Army ARDEC Close Combat Armaments Center Picatinny Arsenal, NJ 07806-5000			10. SPONSORING / MONITORING AGENCY REPORT NUMBER	
11. SUPPLEMENTARY NOTES				
12a. DISTRIBUTION / AVAILABILITY STATEMENT Approved for public release; distribution unlimited			12b. DISTRIBUTION CODE	
13. ABSTRACT (Maximum 200 words) The stress distribution in the wall of a hollow steel cylinder that had been autofrettaged varies from compressive at the inside diameter to tensile at the outside diameter. The question of how the Rockwell-C (R_C) hardness varies with residual stress was treated previously. In order to generalize the previously developed concepts, in this report the hardness in the wall was measured as a function of radial position using various hardness testers. Each of the hardness testers used a different applied load to indent the sample surface to measure its hardness. The residual stress of the sample was measured using ultrasonic techniques. From a model proposed by Frankel, Abbate, and Scholz, the relationship between the residual stress and the onset of plastic deformation was derived, and the experimental dependence of R_C on residual stress was shown. From previous work we saw that the effect of residual stress on measured hardness stems from the effect of stress on the onset of plastic deformation: plastic deformation is delayed and hardness is increased for a compressive residual stress, and plastic deformation is enhanced for a tensile residual stress, therefore the measured hardness is decreased. From this work, we see that the effect is detectable for the tests using larger loads, R_C and Rockwell-D (R_D), and becomes washed out for the tests using lower loads (i.e., less total plastic deformation). The Rockwell-A (R_A) and the Microdur® testers using Vickers indenters did not show the hardness dependence on residual stress. We point out that (a) Rockwell-C and Rockwell-D hardness tests on gun steel should be done with an awareness that residual stress can affect the results, and (b) careful Rockwell-C and Rockwell-D tests can be used to obtain residual stress distribution.				
14. SUBJECT TERMS Residual Stress, Hardness, Plastic Deformation, Yield Criteria, Ultrasonic Inspection			15. NUMBER OF PAGES 28	
			16. PRICE CODE	
17. SECURITY CLASSIFICATION OF REPORT UNCLASSIFIED	18. SECURITY CLASSIFICATION OF THIS PAGE UNCLASSIFIED	19. SECURITY CLASSIFICATION OF ABSTRACT UNCLASSIFIED	20. LIMITATION OF ABSTRACT UL	

TABLE OF CONTENTS

ACKNOWLEDGEMENTS	iii
INTRODUCTION	1
BACKGROUND AND THEORY	1
EXPERIMENTAL PROCEDURE	4
RESULTS	5
DISCUSSION	7
SUMMARY AND CONCLUSION	8
REFERENCES	9

Tables

1. Selection of Residual Stress Measurement Methods	3
---	---

List of Illustrations

1. Brinell Indentation Process: (a) Schematic of the principle of the Brinell indentation process; (b) Brinell indentation with measuring scale in millimeters	10
2. Principle of the Rockwell Hardness Method	11
3. Diamond pyramid indenter used for the Vickers test and resulting indentation in the workpiece: D is the mean diagonal of the indentation in millimeters	12
4. The right circular cylinder in which hardness measurements and ultrasonic residual stress measurements were made	13
5. Schematic of the Microdur® I portable hardness tester	14
6. Schematic of the Microdur® II portable hardness tester	15
7. Schematic of a Standard Rockwell hardness testing machine	16

8. The measured residual hoop stress and calculated radial stress for the sample cylinder plotted as a function of the position	17
9. The Rockwell-C hardness measured using a standard Rockwell hardness tester is plotted as a function of R	18
10. The Rockwell-C hardness plotted as a function of radial position from ID	19
11. The Rockwell-C hardness measured using the Microdur® I portable hardness tester is plotted as a function of R	20
12. The Rockwell-C hardness measured using the Microdur® II portable hardness tester is plotted as a function of R	21
13. The Rockwell-A hardness measured using a standard Rockwell hardness tester plotted as a function of R	22
14. The converted Rockwell-C hardness measurements along with the experimentally-measured Rockwell-A hardness measurements plotted as a function of R	23
15. The converted Rockwell-C hardness measurements along with the experimentally-measured Rockwell-C hardness measurements plotted as a function of R	24
16. The experimentally-measured Rockwell-D and C hardness plotted as a function of R	25

ACKNOWLEDGEMENTS

The authors would like to thank Ellen Fogarty for excellent editorial contributions and Chris Rickard for help in the hardness testing.

Accession For		
NTIS CRA&I		<input checked="" type="checkbox"/>
DTIC TAB		<input type="checkbox"/>
Unannounced		<input type="checkbox"/>
Justification		
By _____		
Distribution/		
Availability Codes		
Dist	Avail and/or Special	
A-1		

INTRODUCTION

The hardness of a metal refers to its ability to resist permanent or plastic deformation by a penetrator and it is determined by measuring the amount of permanent deformation produced by a fixed force acting on the penetrator (usually a hard metallic ball or a specially shaped diamond indenter). The resistance of the metal to deformation is principally a function of its yield strength (ref 1), its modulus of elasticity, and its strain-hardening characteristics (ref 2).

Hardness tests are useful in process quality control and they are simple and inexpensive to perform. Hardness testers rely on the slow application of a fixed force onto an indenter that is forced into the smooth surface of the specimen. After the force is removed, either the area or the depth of the penetration is measured. This measurement is an indication of the resistance to the force. The area or the depth of the penetration is converted into a number called the hardness number. The hardness number for different tests is not universal; a Rockwell-C hardness number for instance does not equal a Brinell hardness number for the same material, however, conversions exist between the two. The methodology, scales, and conversions are empirical.

The residual stress in a metal refers to a system of stresses that can exist in a body when it is free from external forces. This system must be in static equilibrium, and therefore the total force acting on any plane must be zero. The maximum value a residual stress can reach is the yield stress of the material under actual three-dimensional stress conditions.

Residual stresses in a material can be beneficial or harmful because they affect its ability to sustain loads, since a compressive residual stress effectively subtracts from the applied tensile stress and a tensile residual stress adds to an applied tensile stress. This means that if a tensile stress is applied to a material under compressive residual stress, the tensile stress needed to cause yielding or crack propagation in the material will have to be increased. This effectively "strengthens" the material and improves its fatigue limit.

BACKGROUND AND THEORY

The three common types of hardness tests are the Brinell, Rockwell, and Vickers hardness tests.

The Brinell hardness test (See Figure 1) (ref 3) relies on an applied load of 3000 kg acting on a 10-mm hardened steel or carbide ball. After the load is removed, the diameter of the impression made by the ball is measured using a microscope. The Brinell hardness number (BHN) is equal to the applied load divided by the actual area of the impression. Usually the BHN is read directly from a table listing different values of the impression diameter for various applied loads (ref 3).

The Rockwell tests depend on the measurement of the differential depth of the permanent deformation caused by application and removal of differential loads on a diamond Brale indenter. The standard Rockwell tests use a 10-kg load (the minor load) to seat the penetrator firmly in the surface of the specimen. After the application of the minor load, the

depth gauge is zeroed and a larger load (the major load) is applied and then removed. With the minor load still acting, the depth of permanent penetration is measured (see Figure 2) (ref 4). The gauge that measures the depth of penetration is calibrated to read in hardness numbers rather than indentation distance. The standard Rockwell testers use different indenter types and sizes, and also different major loads, therefore a letter has been assigned to each combination of major load and indenter (ref 4).

The Vickers hardness test uses a diamond ground in the shape of an inverted square-based pyramid as a penetrator. A load is applied to the penetrator and the diagonal of the impression made by the indenter is measured by means of a microscope (see Figure 3) (ref 5). The length of the diagonal is converted into a hardness number that is computed by dividing the load by the area of contact. This hardness test is considered a microhardness tester (ref 5).

Residual stresses in many realistic situations are difficult to calculate with any precision by analytical methods, so experimental techniques are usually employed. There are four common methods used to measure residual stress: hole drilling, X-ray diffraction, ultrasonic velocity, and Barkhausen noise analysis (see Table 1).

Since most residual stress problems of practical interest arise in components too large to be moved, there is a need for some residual stress measurement instruments to be portable (ref 6) and give quick and accurate measurements. Each of the methods listed in Table 1 involve detailed techniques and require specific conditions. The residual stress in a test piece with parallel flat surfaces in general can be obtained, but many components to be tested are cumbersome to move. Therefore, an easy-to-use and universal technique would be welcome. Some experimental data has been obtained showing that hardness data is sensitive to applied or residual stresses (refs 1,9-12). By considering the addition of the compressive force generated by the application of the indenter during the hardness test, the effect of residual stress on hardness has been modelled using the von Mises-Hencky criterion (ref 1). For example, if the material tested has a tensile residual stress, yielding would be promoted by the indentation during the hardness test and the apparent hardness of the material would decrease. The reverse would be true if the material tested had a compressive residual stress.

The model was used to find the relationship between the Rockwell-C hardness and the hoop residual stress in three right circular cylinders (see Figure 4) (ref 1) that had been autofrettaged to induce residual stresses. The Rockwell-C hardness test utilizes the depth of indentation under a constant load (150 kg) as a measure of hardness. Each of the common hardness tests--Brinell, Vickers, and Rockwell--are all related to each other, either by means of empirically obtained reference tables or by equations relating the geometrical characteristics of the indentation. The following experiments were conducted to determine the effect of the residual stress on the measured hardness as the applied load and indenter type are varied.

Table 1. Selection of Residual Stress Measurement Methods (ref 6)*

Method	Nondestructive	Reliability	Bulk Stress	Stress Direction	Resolution	Cost Relative	Portability	Speed
Stress relief techniques (mechanical methods)	No	Good	Yes	Yes	~4 mm ³	1 to 10	Yes	Poor
Hole drilling	Partially	Good	No	Yes	> 30 mm ³	1	Yes	Poor
X-ray diffraction	Surface	Good	No	Yes	< 1 mm ³	0.1 to 1	Yes	Poor to excellent
Ultrasonics	Yes	Poor*	Yes	Yes	> 5 mm ³	< 0.1	Yes	Excellent
Barkhausen noise	Surface	Poor	No	Yes	> 10 mm ³	< 0.1	Yes	Excellent

3

*This method yields high reliability and accuracy when the experimental procedure was utilized by present authors (refs 1,8).

EXPERIMENTAL PROCEDURE

The samples used for this experiment were hollow right circular cylinders from an autofrettaged 4340 steel gun tube (see Figure 4) (ref 1). The samples were approximately 150 mm at the inside diameter (ID), 300 mm at the outside diameter (OD), and 50 mm thick. Autofrettage is a process in which an oversized mandril is pushed through a gun tube causing plastic deformation inside the tube and expanding the bore. As the bore expands, the OD is placed in tension. Since the deformation at the bore is permanent or plastic, the tension at the outside as well as the compression at the bore are permanent, thereby increasing the resistance of the system to crack growth from the ID. The flat faces of the cylinder were ground smooth and parallel to give proper surface conditions for hardness and ultrasonic measurements.

First the residual stress in the hoop direction was measured using a technique that utilizes ultrasonic velocity measurements. A 5-MHz shear transducer with a high viscosity liquid bond was placed on a flat face of the sample. Shear wave velocity measurements were made starting from the OD of the cylinder and moving toward the inside at 3-mm increments. The change in velocity (Δv) was measured by observing the change in return time on an oscilloscope screen. This change in wave return time was used to calculate the residual stress of the sample. The change in wave velocity is related to the residual stress by $\Delta v/v = k\sigma$, where k is the stress-acoustic constant for the steel and σ is the residual stress (refs 1,8).

The next procedure was to measure the hardness of the cylinder using a variety of hardness tests:

The first test used a Microdur® I portable hardness tester (see Figure 5) (ref 7) manufactured by the Krautkrämer Company (GMBH) Hürth, Germany. This is a Vickers low load hardness tester with indentation evaluation according to the Ultrasonic Contact Impedance (UCI) method. The Microdur® I uses a Vickers diamond that is excited to a point of oscillation by a piezo-electric converter. Since unimpeded oscillations have a certain frequency that change as the diamond penetrates the test materials, the size of the indentation and therefore the change in frequency increases in relation to the decrease in material hardness. The indenter used was a diamond pyramid according to Vickers with a roof angle of 136 degrees and the testing load was 7.7 N or 0.785 kg (ref 7). This test load was applied to the diamond tip by a small motor that drives the rod into the active or non-active position. Using the Microdur® I along with a specially fabricated clamp to ensure that the sample surface was perpendicular to the tester, hardness measurements were taken every 3 mm in a radial direction across the sample cylinder. The hardness measurements obtained were taken and the average of these five lines were accepted as the true hardness of that particular region.

The second test was the Microdur® II portable hardness tester (see Figure 6) (ref 7). The indenter used was a diamond pyramid according to Vickers with a roof angle of 136 degrees and the testing load was 49.05 N or 5.0 kg (ref 7). The hardness of the sample was measured by using the Microdur® II portable hardness tester in the following operation: The indenter is pressed against the sample surface, compressing an internal spring, thus increasing the load applied to the diamond tip. Upon reaching the required testing load of precisely 5.0 kg, the indentation is evaluated (ref 7). The hardness is displayed in values of Rockwell-C hardness numbers. This probe was also fitted with a clamp to ensure that the tester was always

perpendicular to the surface of the sample. The procedure for actually measuring the hardness of the sample was the same as that described for the Microdur® I portable hardness tester, except here only four lines were measured.

Third, the Rockwell hardness test was performed. Using a standard Rockwell hardness tester (see Figure 7) (ref 4), the hardness of the sample was measured using three different major loads, 60, 100, and 150 kg, with a diamond Brale indenter. The Rockwell-C (R_C) scale was used when a major load of 150 kg was applied, the Rockwell-D (R_D) scale was used for the 100-kg load, and the Rockwell-A (R_A) scale was used for the 60-kg load. Hardness measurements of the sample were made as a function of radial position starting at the OD of the cylinder and moving toward the center at 3 mm increments. Three lines of hardness measurements were made and averaged for Rockwell-C, D, and A. In each case calibration procedures were followed according to ASTM specification and instrument manufacturer's suggestion, i.e., the hardness readings were checked against test blocks supplied with the instrument.

RESULTS

The residual stress measured by ultrasonic techniques was plotted as a function of R as shown in Figure 8. We use the abscissa, R , as the measured position of interest (X) minus the ID divided by the OD minus the ID ($R = [X - ID] / [OD - ID]$). It is seen that the hoop residual stress is compressive at the ID and becomes more tensile as the distance from the ID is increased. In Figure 9 the R_C hardness data of one cylinder is plotted as a function of R . The actual hardness readings, as well as the calculated average of the four hardness readings, are plotted. As can be seen, as R increases from 0 to 1, the hardness decreases. This corresponds to the fact that as R increases from 0 to 1 in Figure 8, the residual stress changes from compressive to tensile. The model proposed in 1 predicts that as the residual stress changes from compressive to tensile, the hardness of the sample should decrease. The relationship corresponds to the definition of hardness: the hardness of a metal is its ability to resist permanent or plastic deformation from an indenter (ref 2). When the sample has a compressive residual stress, the hardness should be higher than when it has a tensile residual stress, because compressive residual stress requires a higher compressive stress (provided by the indenter) to cause yielding or plastic deformation to deform the metal as occurs in hardness measurements.

In Figure 10 the experimental R_C hardness data of the cylinder is plotted as a function of R . The curve fit in the plot is the calculated R_C hardness from residual stress using the model (ref 1).

In Figures 11 and 12, the R_C hardness measured using the Microdur® I and II portable hardness testers is plotted as a function of R . These hardness testers use a Vickers diamond indenter to measure the hardness and the values are converted to R_C . As seen in Figure 11, the hardness readings obtained using this method are fairly uniform (invariant) along the radius of the sample; the average hardness is $47.2 \pm 1.1 R_C$. As seen from the standard deviation of the data, there is quite a wide variation from the average using this method. Using the standard R_C hardness tester, the measured hardness varied from $43 \pm 0.33 R_C$ at the OD to $38 \pm 0.33 R_C$ at the ID. Therefore, it can be concluded that the hardness measured using the Microdur® I did

not correspond to the true hardness of the sample. Since the Microdur® I measures the microhardness, the values obtained are strongly dependent on the surface finish of the sample, grain orientation, dislocation density, and/or surface hardening due to sample preparation. All these are largely uncontrolled variables. Although these effects should be expected in tests with both indenters, it seems that due to the higher load and larger indenter in the R_C test, the effect of residual stress on plastic deformation here outweighed the effects that could not be controlled in the experiment. These uncontrolled effects in the Microdur® test cause the larger scatter in the hardness values.

In Figure 12, the average hardness of the data is $45.8 \pm 0.91 R_C$. The scatter in Figures 11 and 12 is much greater than in Figure 9. Since the Microdur® portable hardness testers measure microhardness, which is very dependent on surface finish, the reason for this scatter is most likely the surface finish. The surface of the sample was ground smooth enough for ultrasonic measurements to be taken. However, a surface roughness (R_a) of the sample was not smooth enough ($R_a \leq 0.25 \mu\text{m}$) to obtain accurate results using these portable hardness testers. A problem with these testers in evaluating residual stress is that the applied load for the Microdur® I and II is 0.785 kg and 5.0 kg, respectively. Since the accuracy of the microhardness of a material is very dependent on the applied load, one would expect that as the applied load is increased, as is the case when using the Microdur® II as opposed to the Microdur® I, the accuracy of the measurements should increase. The accuracy of both Microdur® portable hardness testers was about the same. Although the Microdur® portable hardness testers did not give extremely accurate hardness measurements on the sample, they did produce accurate results when testing the hardness of standardized test blocks. These test blocks are the standard blocks used to calibrate the hardness testers. The surface of these test blocks is extremely flat--typically a surface roughness of $\leq 25 \mu\text{m}$. The manufacturer of these portable hardness testers recommends that for cases requiring extreme precision, the quality of the test piece surface should be equal to that of a standard test block.

The R_A hardness of the sample was measured using a standard Rockwell hardness tester, and the results are plotted as a function of R in Figure 13. The average hardness is $69.7 \pm 0.87 R_A$. The R_A hardness tester is usually used to measure the hardness of cemented carbides, thin steel, and shallow case-hardened steel, whereas R_C is usually used to measure steel, hard cast iron, pearlitic malleable iron, and deep case-hardened steel. Using a conversion table (ref 4) to convert the average R_A to R_C , the results were plotted in Figure 14 as a function of position. In Figure 14 it is shown that when the average R_A hardness is converted to R_C hardness, the relationship is not the same as in Figure 9. Although the R_A hardness did decrease as R increased, the decrease in the hardness was not as great as experienced in Figure 9 when experimental R_C hardness was measured.

In Figure 15 the converted R_C hardness from Figure 14 and the experimentally-measured R_C hardness from Figure 9 are plotted as a function of position. Here it can be seen that the converted R_C hardness and the experimentally-measured R_C hardness do not overlap, therefore the conversion is not valid in the presence of residual stress.

The R_D hardness of the sample was measured using a standard Rockwell hardness tester, and the results along with the R_C hardness values are plotted as a function of R in Figure 16. By plotting the two hardness values on the same figure, it can be seen that both R_C and R_D show a relationship to the residual stress, but the R_D (with lesser load) showed larger scatter. The average hardness of the data is $55.0 \pm 0.95 R_D$.

DISCUSSION

Since the cylindrical sample used in this experiment had been cut and polished for ultrasonic inspection, the residual stress at the surface was changed during the sample preparation. The ultrasonic techniques used to measure the residual stress in the sample assume that this stress is uniform throughout the thickness of the sample. Since the residual stress at the surface was changed during sample preparation, the effect of residual stress on hardness is dependent on the depth of the indentation employed during hardness measurements. The hardness testers that apply a relatively low load on the indenter during measurements (such as the Microdur® I and II) measure the surface hardness of the sample. However, hardness testers, in which the applied load is substantial enough to penetrate the surface layer where the residual stress has changed, would most likely measure the hardness of the sample where surface effects are muted.

For the Microdur® portable hardness testers, the Vickers diamond pyramid indenter is used. The hardness tester converts the measured Vickers hardness number into the R_C hardness number that is then given as data. In order to do this, the relationship between Vickers and R_C hardness is assumed to be linear and the validity of this assumption in the presence of residual stress is untested.

As seen in Figure 15, the converted R_C hardness numbers and the experimental R_C hardness numbers show very little correlation. This could mean that the relationship between the R_C and the R_A hardness is not linear. When using a conversion table to obtain one hardness from another, the assumption of linearity is implicit. The experimental data presented here shows that if a metal contains residual stresses, then the conversion of hardness numbers from one type to another is not simply a linear conversion process. Since residual stress is present in most commercially available metals, with the implied assumption of linearity between hardness numbers using different tests, a relationship must include the effects of residual stress in the metals and thereby compensate for the non-linearity that exists in real alloys.

One explanation for the non-linearity of the hardness numbers measured using different testers is that the residual stress present in the metal affects the penetration of the indenter into the metal. When the residual stress is compressive in nature, the pressure needed to cause yielding is greater than when only a tensile residual stress is present. The effect of residual stress is also dependent on the contact area of the indenter. Different hardness testers use different indenters to penetrate the metal, and the contact area, as well as its load dependence, is different for different indenters.

The Microdur® portable hardness testers use the UCI method (ref 7). As the Vickers diamond comes in contact with the sample, the resonance frequency changes relative to the size of the indentation area. The hardness is calculated from this change in the resonance frequency. Here the hardness is measured under an applied load, so the effects of plastic as well as elastic deformation are both considered when this method is used. The residual stresses present in the metal should have no effect on the amount of elastic deformation the indenter produces during the hardness measurement (Theory of Superposition). As seen in Figure 16, a correlation between the R_C and R_D hardness values can be seen. Since the R_C and the R_D tests use major loads of 150 and 100 kg, respectively, the plastic deformation is much more pronounced compared to the other tests performed. An argument can be made that because of the plastic deformation, the effect of residual stress is best seen in the R_C test in terms of the model proposed in Reference 1. There the effect of residual stress on hardness is understood in terms of the initiation of plastic deformation by the three-dimensional stress state (von Mises-Hencky Principle) (ref 2). Since the plastic deformation in the R_C test is higher, the effects of the plastic deformation are more likely to dominate other effects such as surface condition or any other surface anomaly that exists.

The Microdur® portable hardness tester results can be strongly influenced by the surface roughness or surface treatment, since their penetration depth is relatively shallow. The Microdur® have typical calculated penetration depths of 11.2 μm and 28.7 μm , respectively. Typical surface roughness of the sample studied is equal to or greater than 0.25 μm . Consequently, the surface roughness effects on the hardness are minimized even in this extreme case.

SUMMARY AND CONCLUSION

The effect of residual stress on R_C hardness had been measured experimentally and effectively modelled (ref 1). Here measurements were extended to other hardness testers using less load (R_D and R_A), smaller indenters, and vibrational hardness determination (Microdur® I and Microdur® II) in addition to repeating the R_C tests.

Only R_C and R_D , the tests with the highest applied load, showed the effect of residual stress.

The difference between the hardness values that showed the effect and those that did not is the load applied. For a larger load there is more plastic yielding, and for more yielding there is more strain which translates into permanent indentation. This means that with the parameters of these experiments, the effect of residual stress that affects the onset of plastic deformation is more easily seen when the plastic deformation is greater.

The vibrational tests in addition to their small indentation are more sensitive to surface residual stresses and to individual grains--quantities that were uncontrolled in this experiment and hence tended to cause larger scatter and obliterate the effect of the measured residual stress in the results.

REFERENCES

1. J. Frankel, A. Abbate, and W. Scholz, "Measurement and Theory of the Dependence of Hardness on Residual Stress," *Journal of Experimental Mechanics*, pp. 164-168, June 1993.
2. G.E. Dieter, *Mechanical Metallurgy*, McGraw-Hill Book Co., New York, 1986, Chapter 3 and 9.
3. A.R. Fee, R. Segabache, and E.L. Tobolski, "Brinell Hardness Testing," in: *Metals Handbook*, Vol. 8, 9th ed., pp. 84-89.
4. A.R. Fee, R. Segabache, and E.L. Tobolski, "Rockwell Hardness Testing," in: *Metals Handbook*, Vol. 8, 9th ed., pp. 74-83.
5. A.R. Fee, R. Segabache, and E.L. Tobolski, "Knoop and Vickers Microhardness Testing," in: *Metals Handbook*, Vol. 8, 9th ed., pp. 90-97.
6. C.O. Ruud, "A Review of Selected Non-Destructive Methods for Residual Stress Measurements," *NDT Int.*, Vol. 15, No. 1, February 1982, pp. 15-23.
7. P.A. Meyer and D.P. Lutz, "Ultrasonic Microhardness Testing," in: *Metals Handbook*, Vol. 8, Ninth Edition, pp. 99-103.
8. J. Frankel, W. Scholz, G. Capsimalis, and W. Korman, "Residual Stress Measurement in Circular Steel Cylinders," *Proceedings of the Ultrasonic Symposium*, 1983, pp. 1009-1012.
9. G. Sines and R. Carlson, "Hardness Measurements for Determination of Residual Stresses," *ASTM Bulletin*, February 1952, pp. 31-33.
10. T.R. Simes, S.G. Mellor, and D.A. Hills, "A Note on the Influence of Residual Stress on Measured Hardness," *Journal of Strain Analysis*, Vol. 19, No. 2, 1984, pp. 135-137.
11. P.A. Blain, "Influence of Residual Stress on Hardness," *Metal Progress*, January 1957, pp. 99-100.
12. S. Kokubo, "On the Change in Hardness of a Plate Caused by Bending," *Material Deformation*, Vol. 3, No. 21, 1932, pp. 256-267.

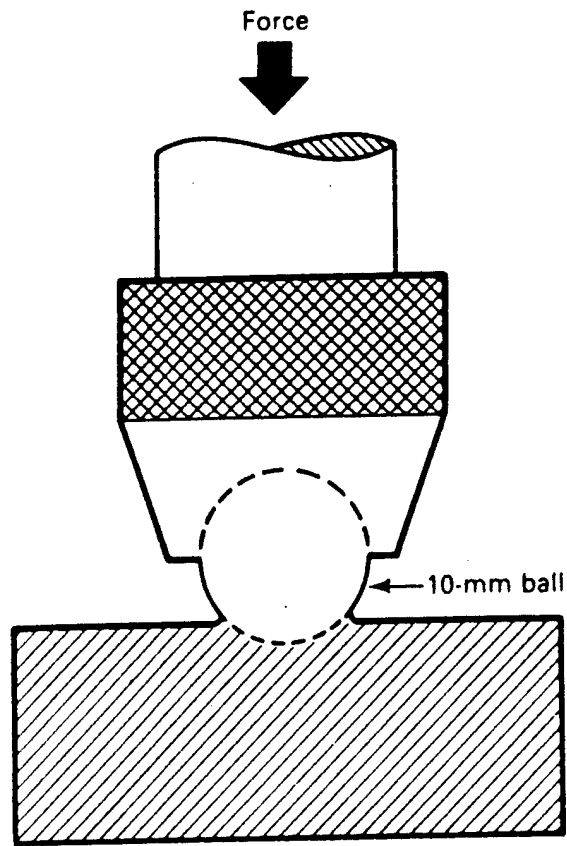

(a)

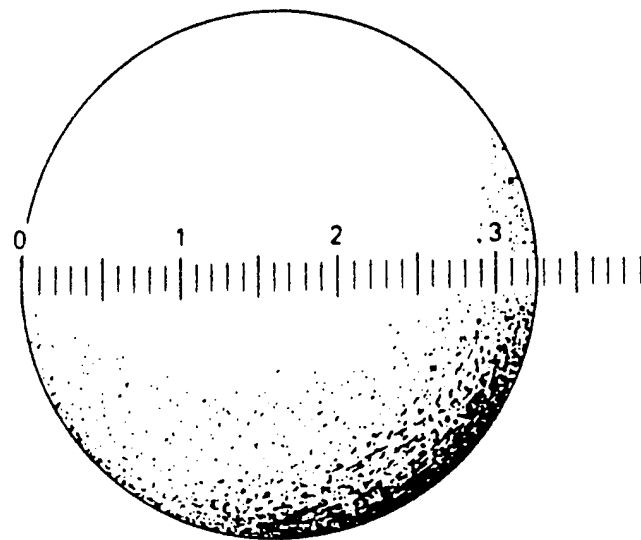

(b)

Figure 1. Brinell Indentation Process: (a) Schematic of the principle of the Brinell indentation process; (b) Brinell indentation with measuring scale in millimeters.

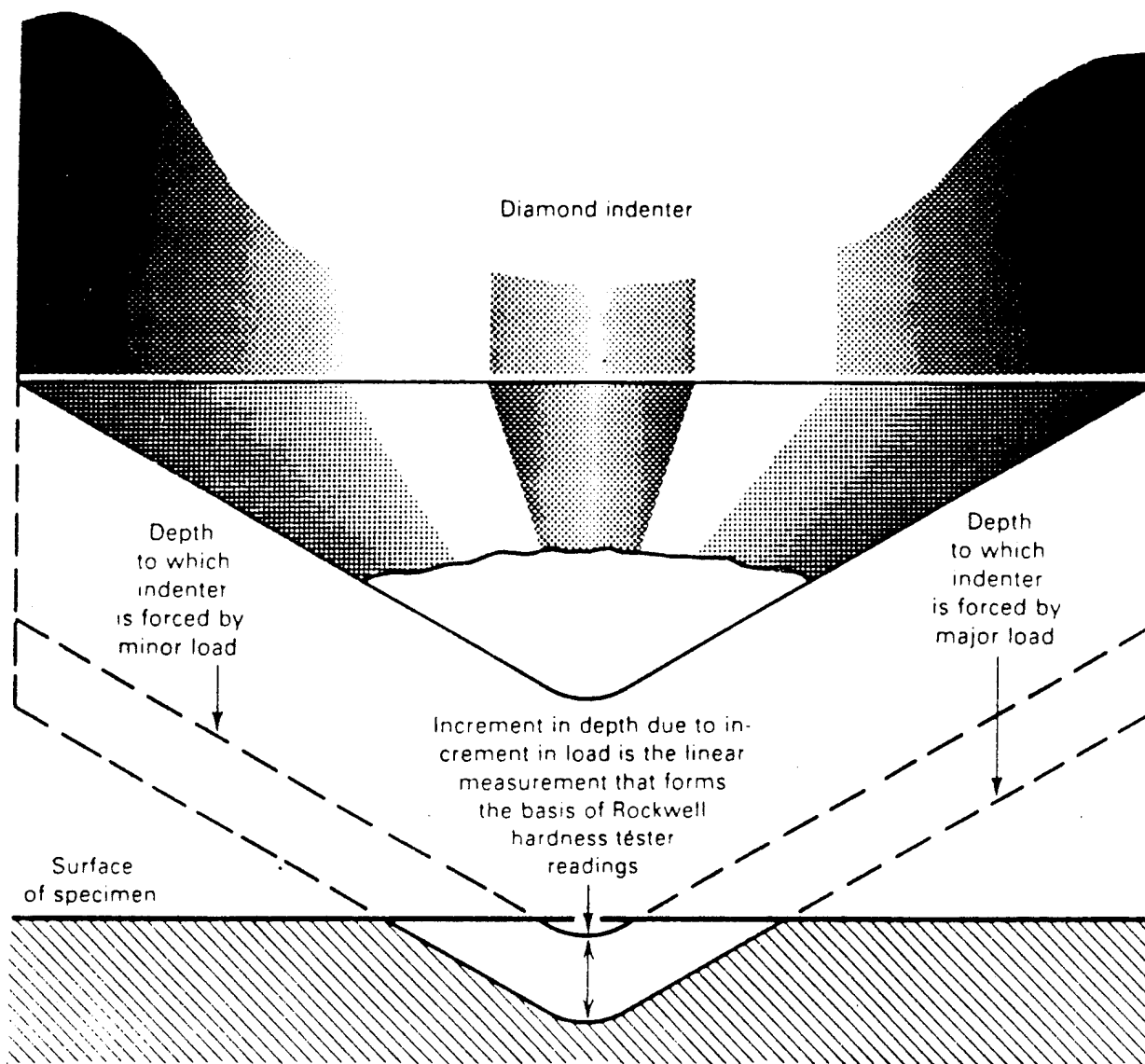

Figure 2. Principle of the Rockwell Hardness Method.

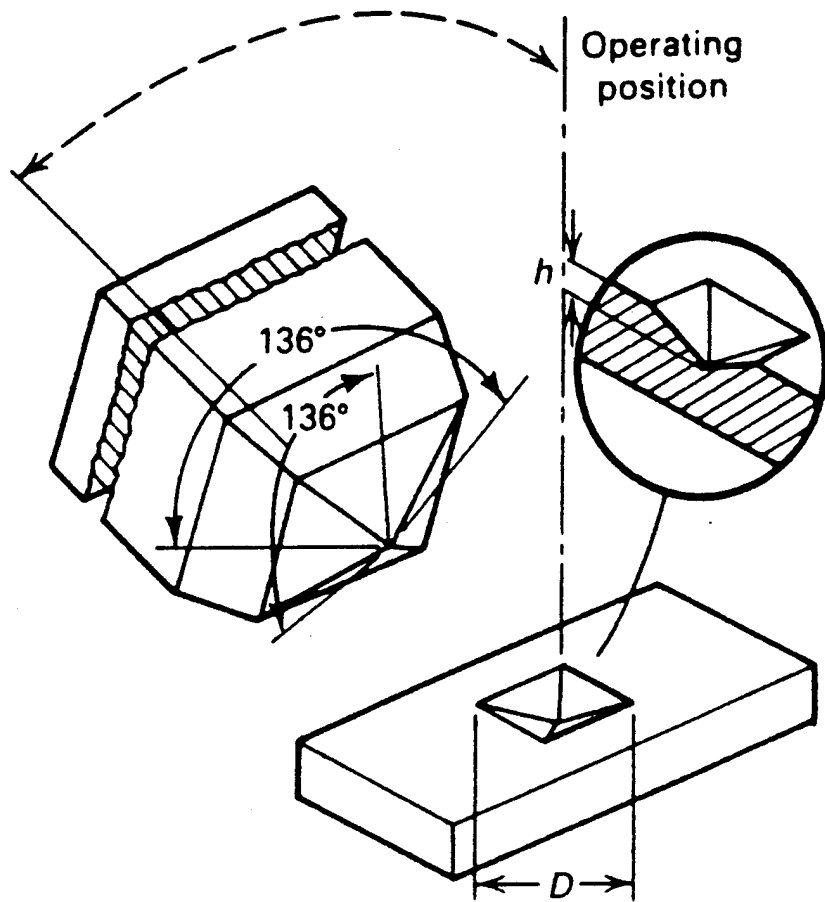

Figure 3. Diamond pyramid indenter used for the Vickers test and resulting indentation in the workpiece: D is the mean diagonal of the indentation in millimeters.

Acoustic Transducer

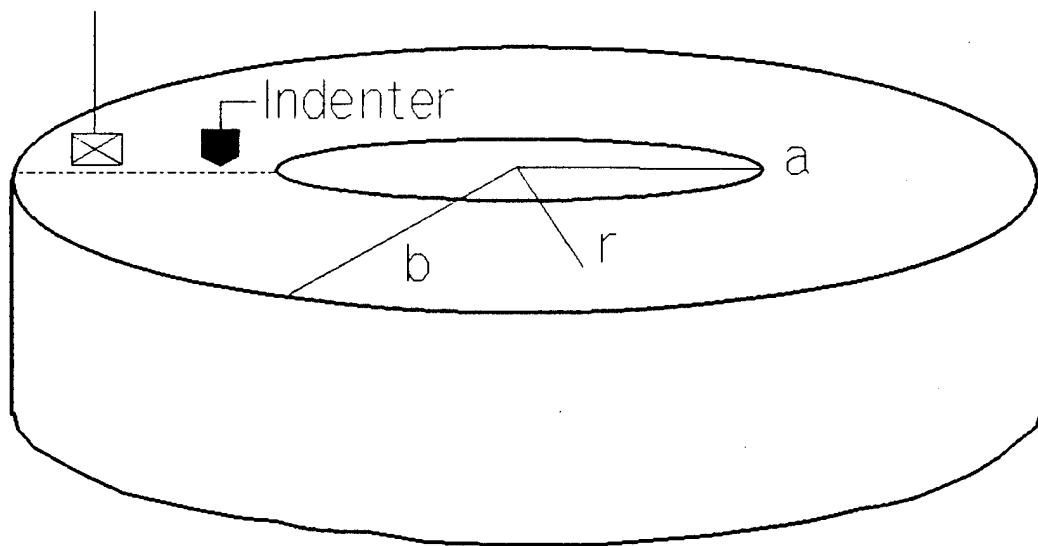
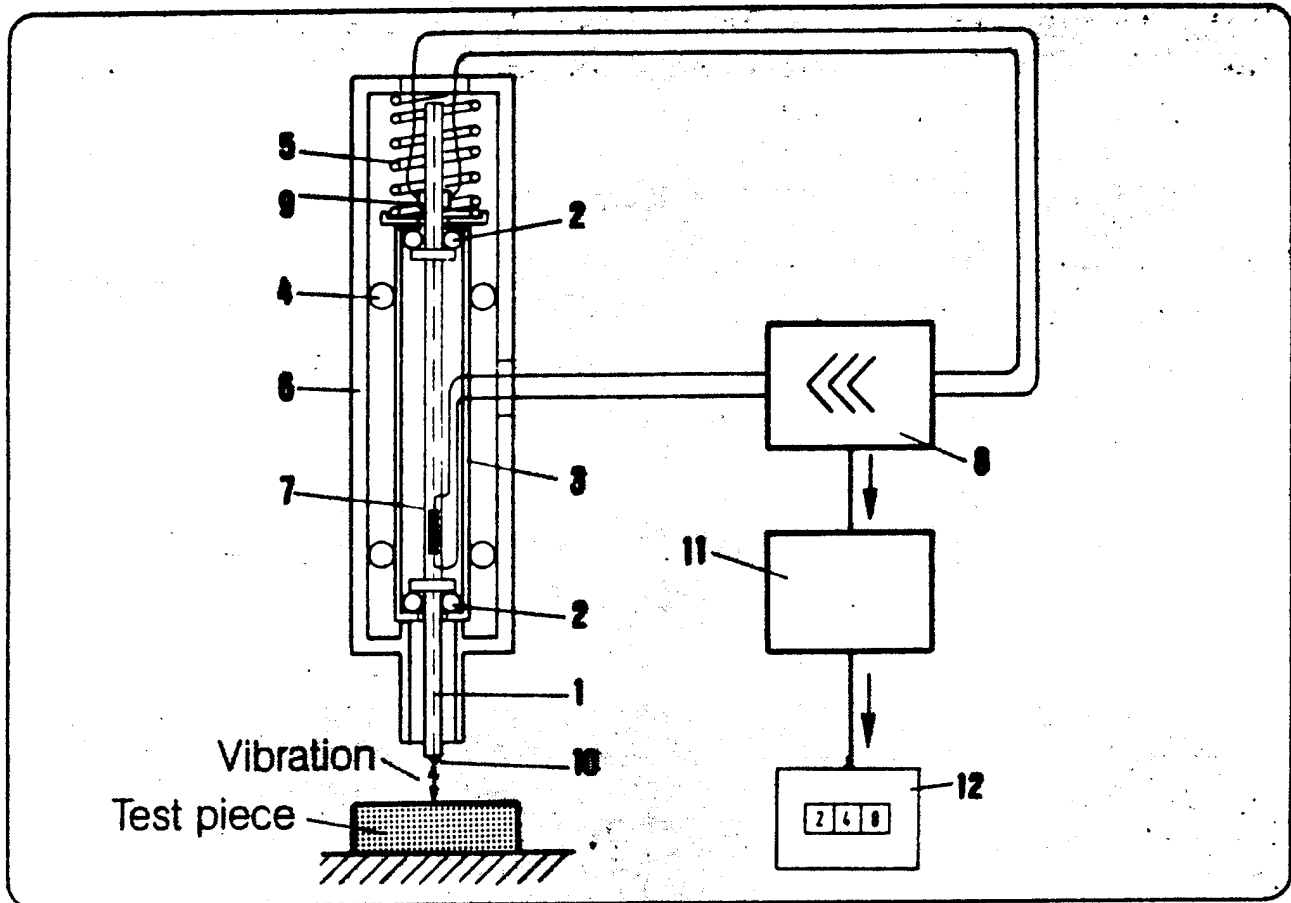

Figure 4. The right circular cylinder in which hardness measurements and ultrasonic residual stress measurements were made.



5 = oscillating rod, 2 = rubber seal, 3 = metal sleeve, 4 = ball bearing bushings, 5 = special spring,
 6 = housing, 7 = oscillating converter, 8 = amplifier, 9 = oscillation detector, 10 = diamond tip,
 11 = frequency discriminator, 12 = ammeter

Figure 5. Schematic of the Microdur® I portable hardness tester.

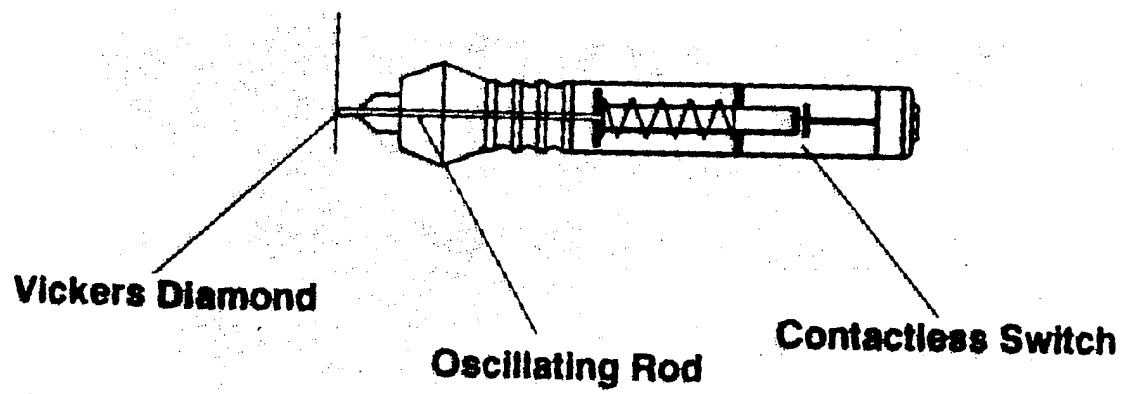

Figure 6. Schematic of the Microdur® II portable hardness tester.

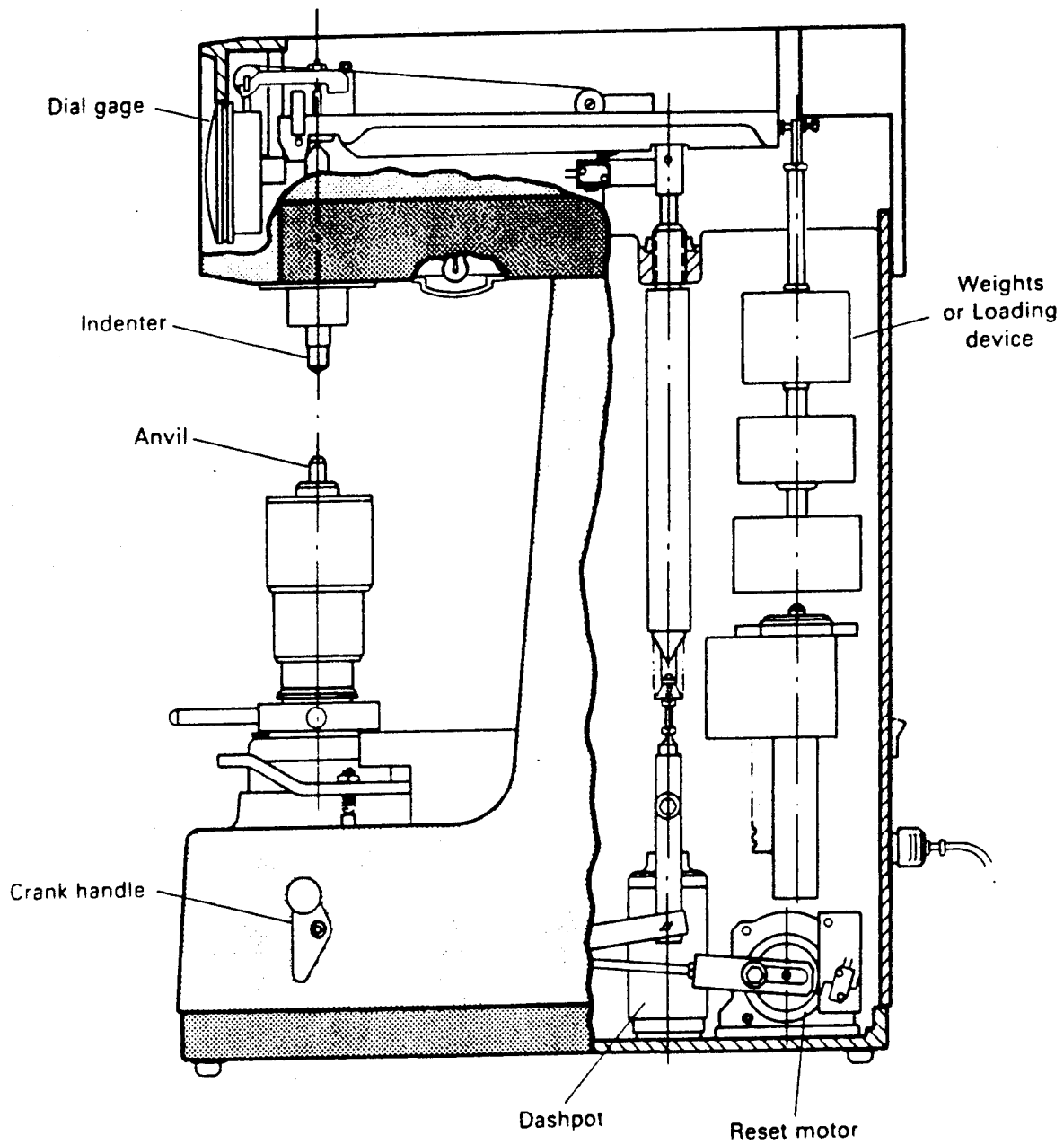

Figure 7. Schematic of a Standard Rockwell hardness testing machine.

FIGURE #8

RESIDUAL STRESS MEASUREMENTS

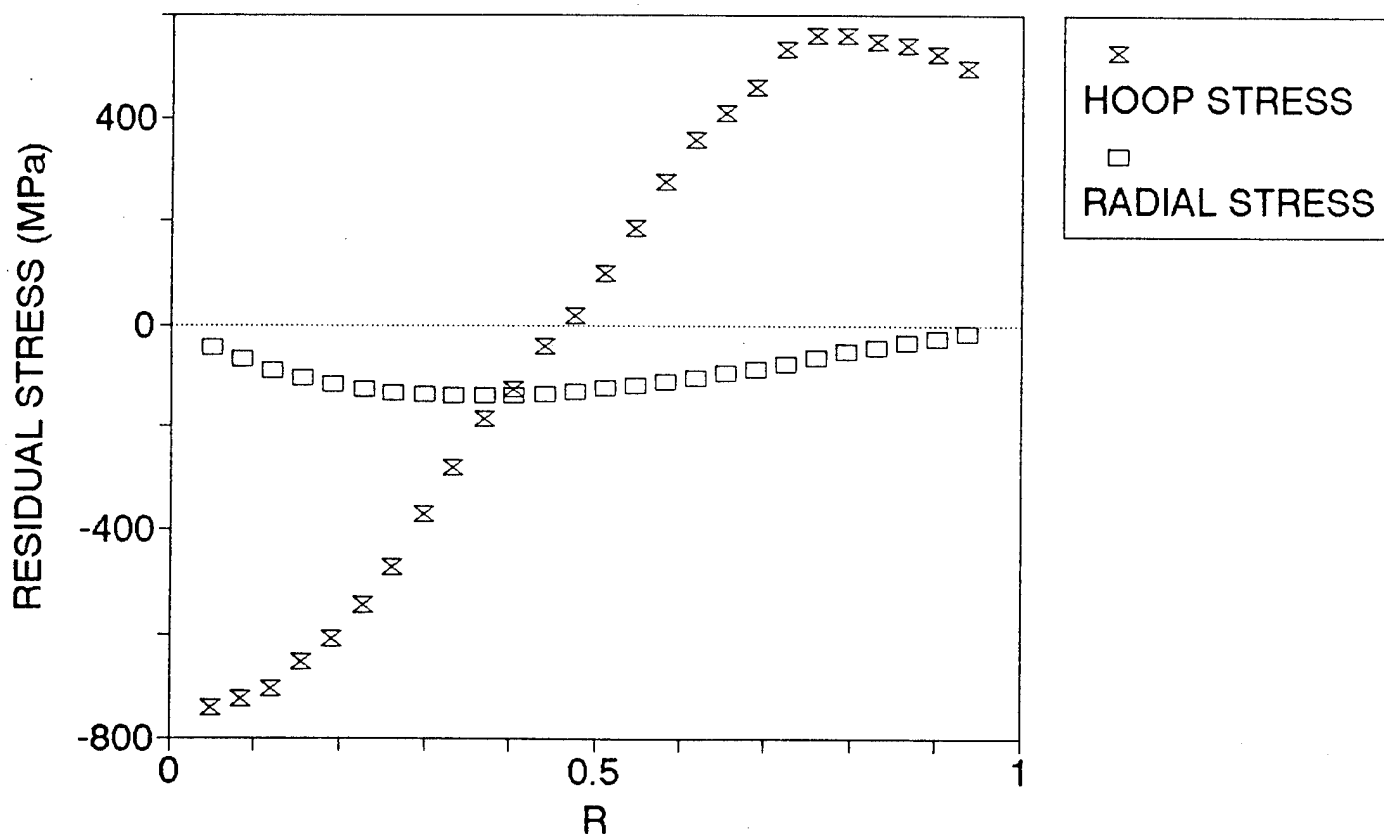

Figure 8. The measured residual hoop stress and calculated radial stress for the sample cylinder plotted as a function of the position. Zero position corresponds to the ID of the cylinder while 1 corresponds to the OD.

FIGURE #9

ROCKWELL-C MEASUREMENTS OF SAMPLE G

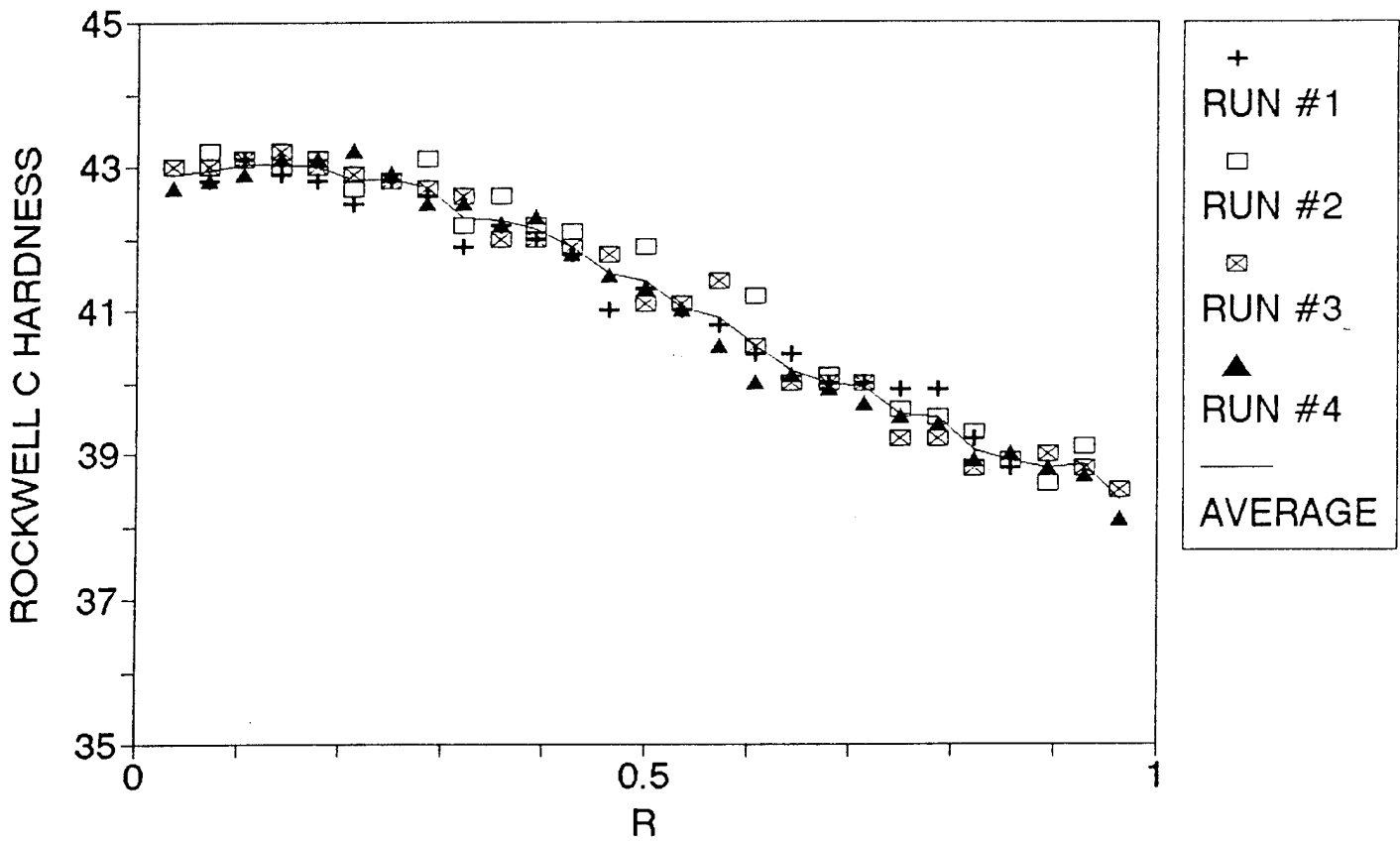

Figure 9. The Rockwell-C hardness measured using a standard Rockwell hardness tester is plotted as a function of R. The symbols represent the experimentally-measured hardness values, while the solid line represents the average hardness.

FIGURE #10

ROCKWELL-C MEASUREMENTS OF SAMPLE G

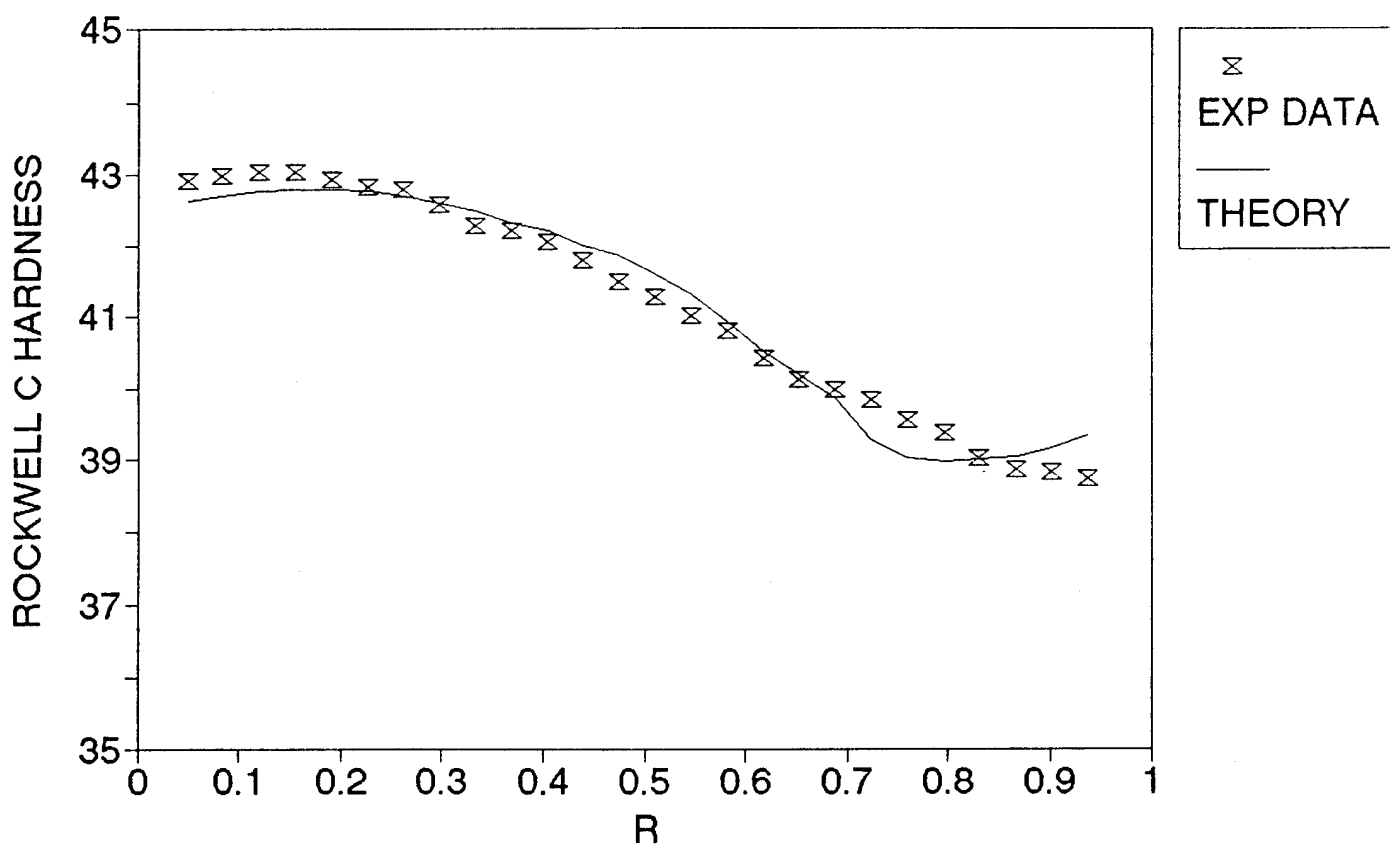

Figure 10. The Rockwell-C hardness plotted as a function of radial position from ID. The symbols represent the experimentally-measured hardness values, while the solid line represents the predicted hardness using the α parameter and theory presented in Frankel, Abbate, and Scholz (ref 1).

FIGURE #11

MICRODUR I-R_C HARDNESS OF SAMPLE G

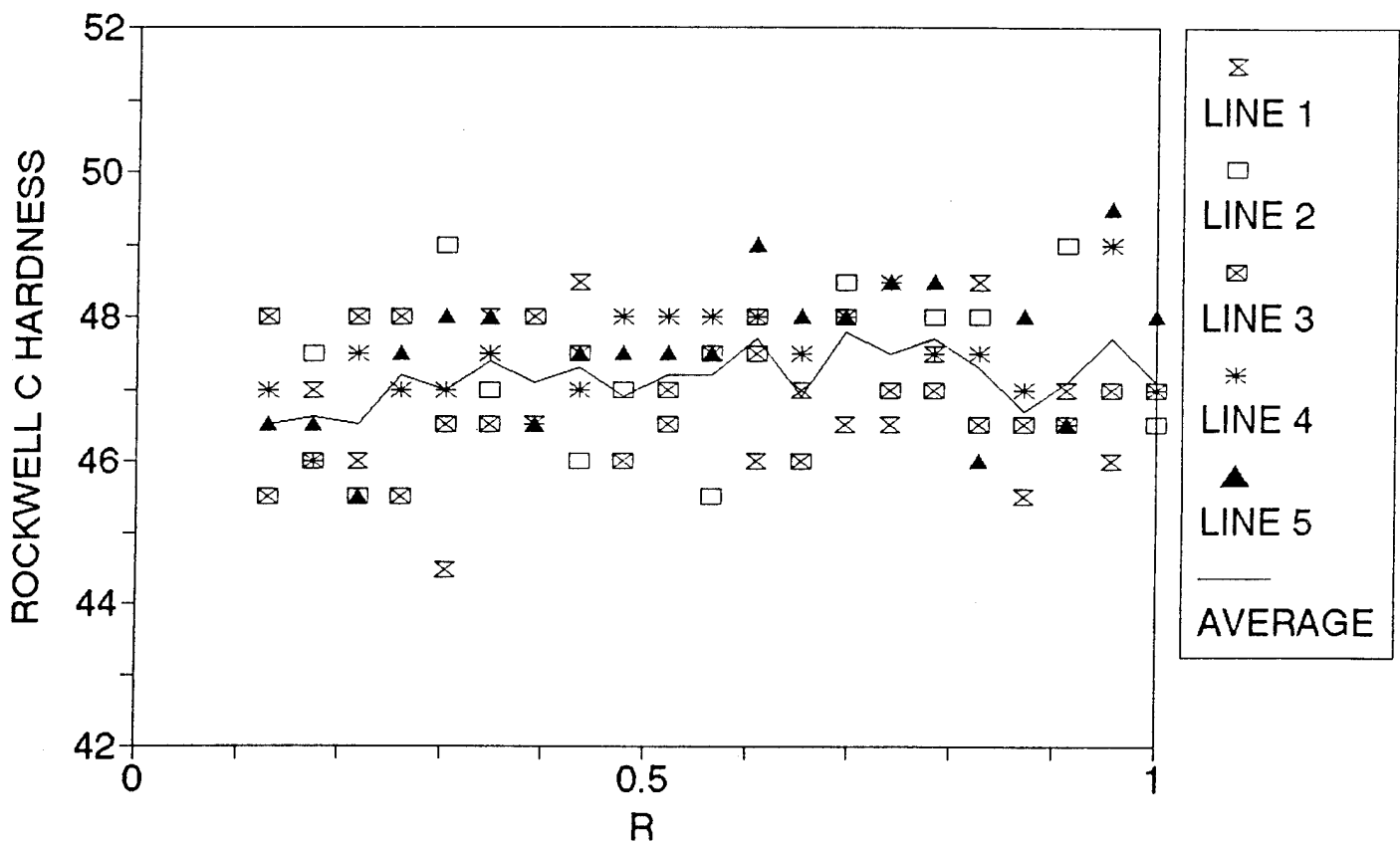

Figure 11. The Rockwell-C hardness measured using the Microdur® I portable hardness tester is plotted as a function of R. The symbols represent the experimentally-measured hardness values, while the solid line represents the average hardness.

FIGURE #12

MICRODUR II-R_C HARDNESS OF SAMPLE G

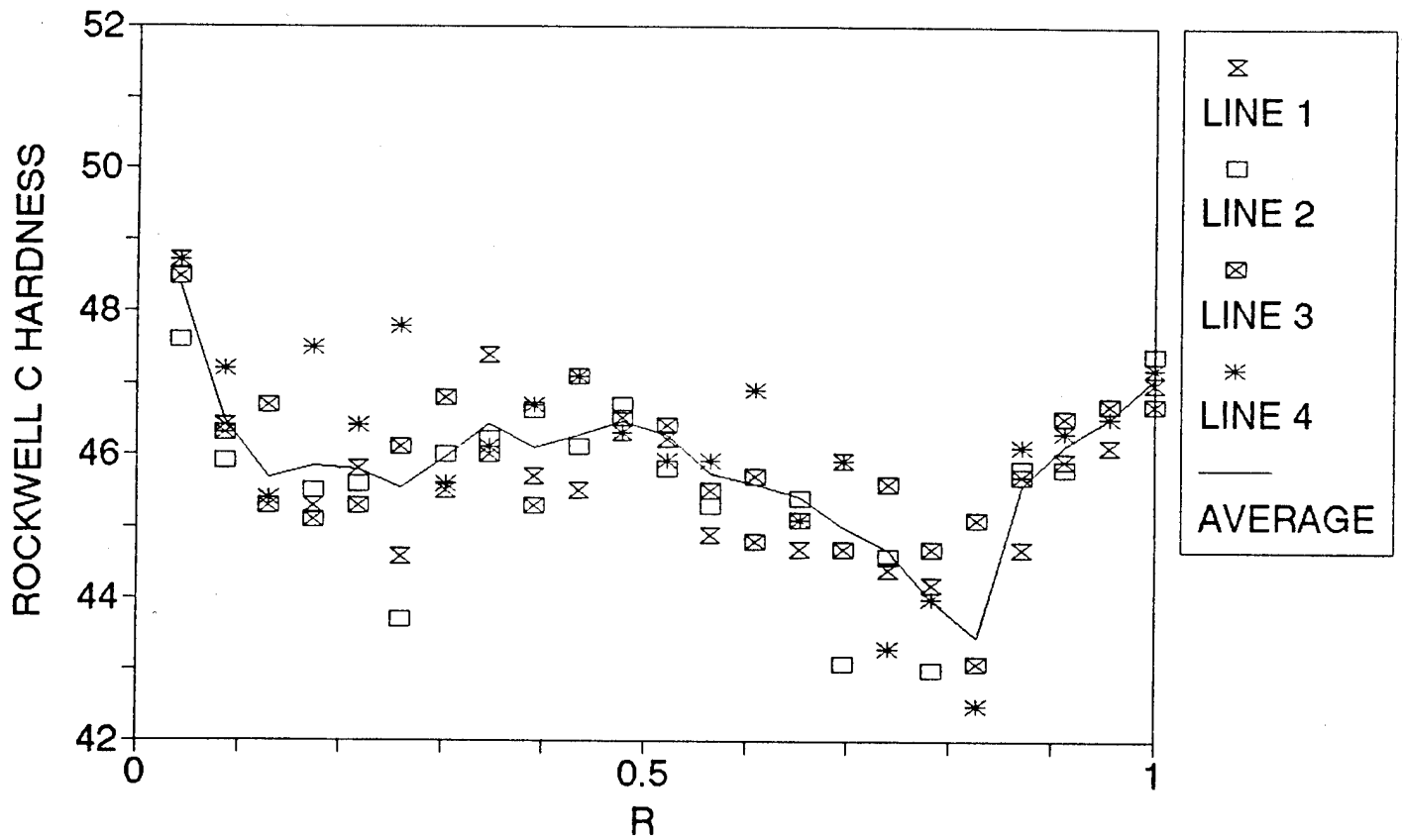

Figure 12. The Rockwell-C hardness measured using the Microdur® II portable hardness tester is plotted as a function of R. The symbols represent the experimentally-measured hardness values, while the solid line represents the average hardness.

FIGURE #13

ROCKWELL A HARDNESS OF SAMPLE G

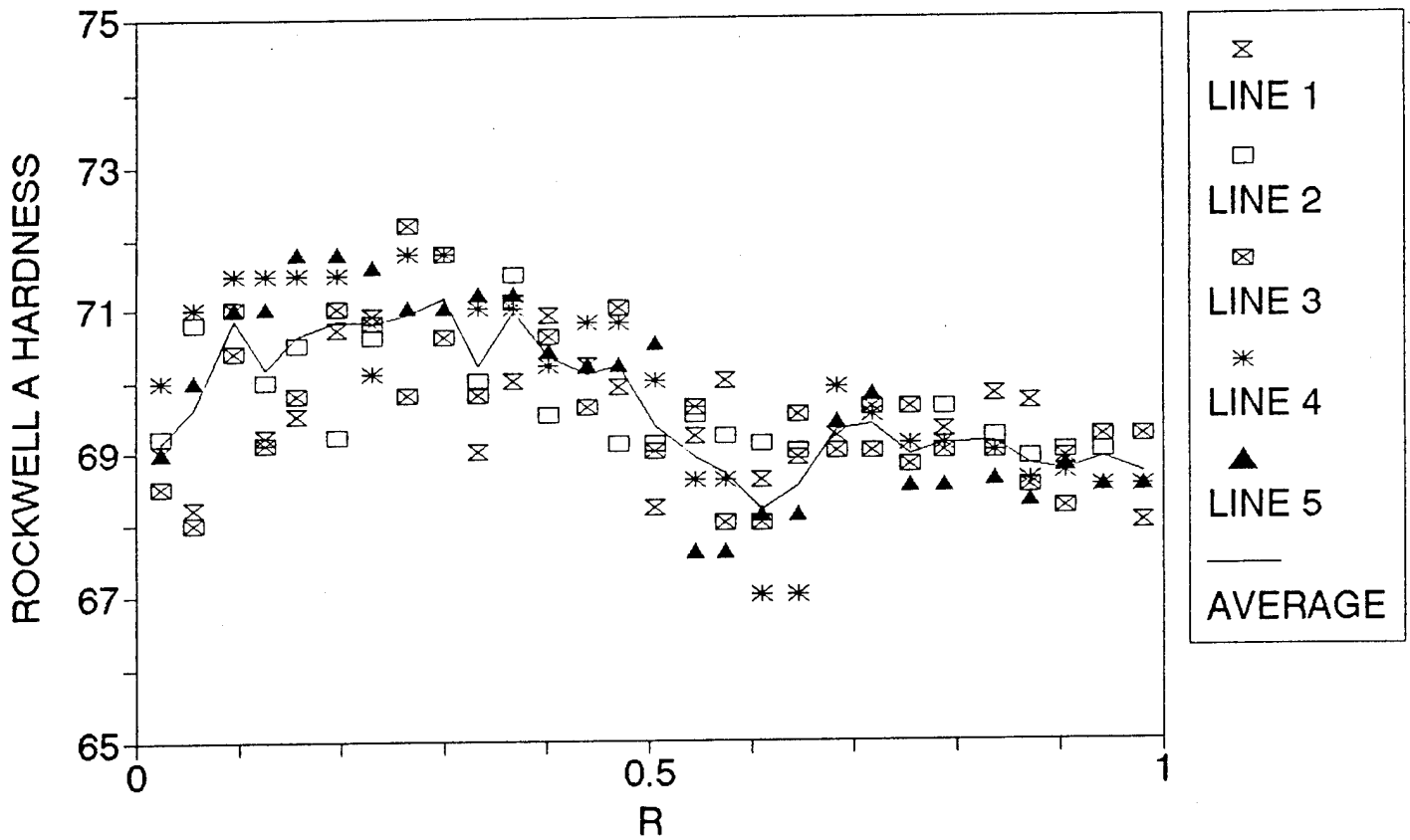

Figure 13. The Rockwell-A hardness measured using a standard Rockwell hardness tester is plotted as a function of R. The symbols represent the experimentally-measured hardness values, while the solid line represents the average hardness.

FIGURE #14

ROCKWELL A AND C HARDNESS OF SAMPLE G

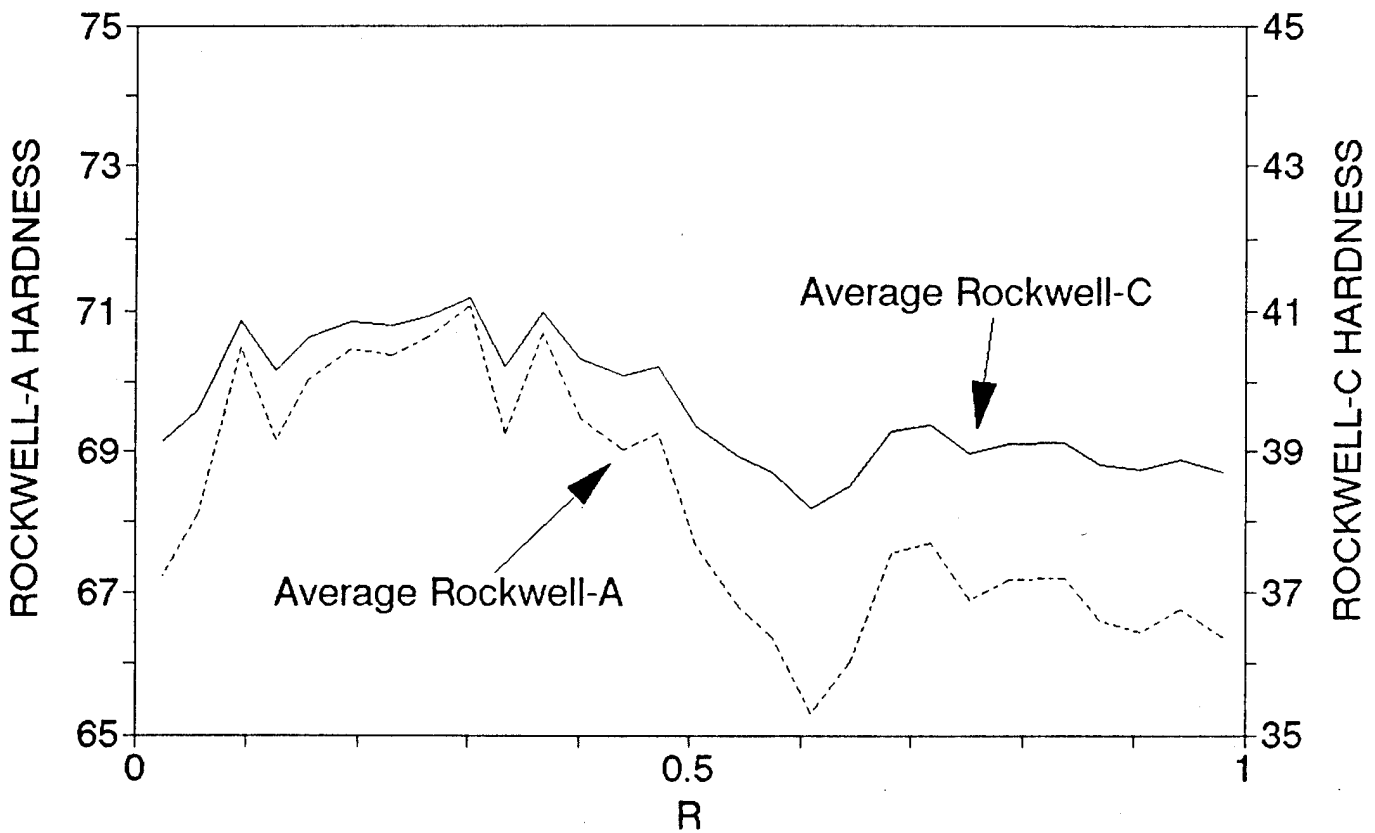

Figure 14. The converted Rockwell-C hardness measurements along with the experimentally-measured Rockwell-A hardness measurements plotted as a function of R. The solid line represents the experimentally-measured Rockwell-A hardness values and the dotted line represents the converted Rockwell-C hardness values.

FIGURE #15

ROCKWELL-C HARDNESS OF SAMPLE G

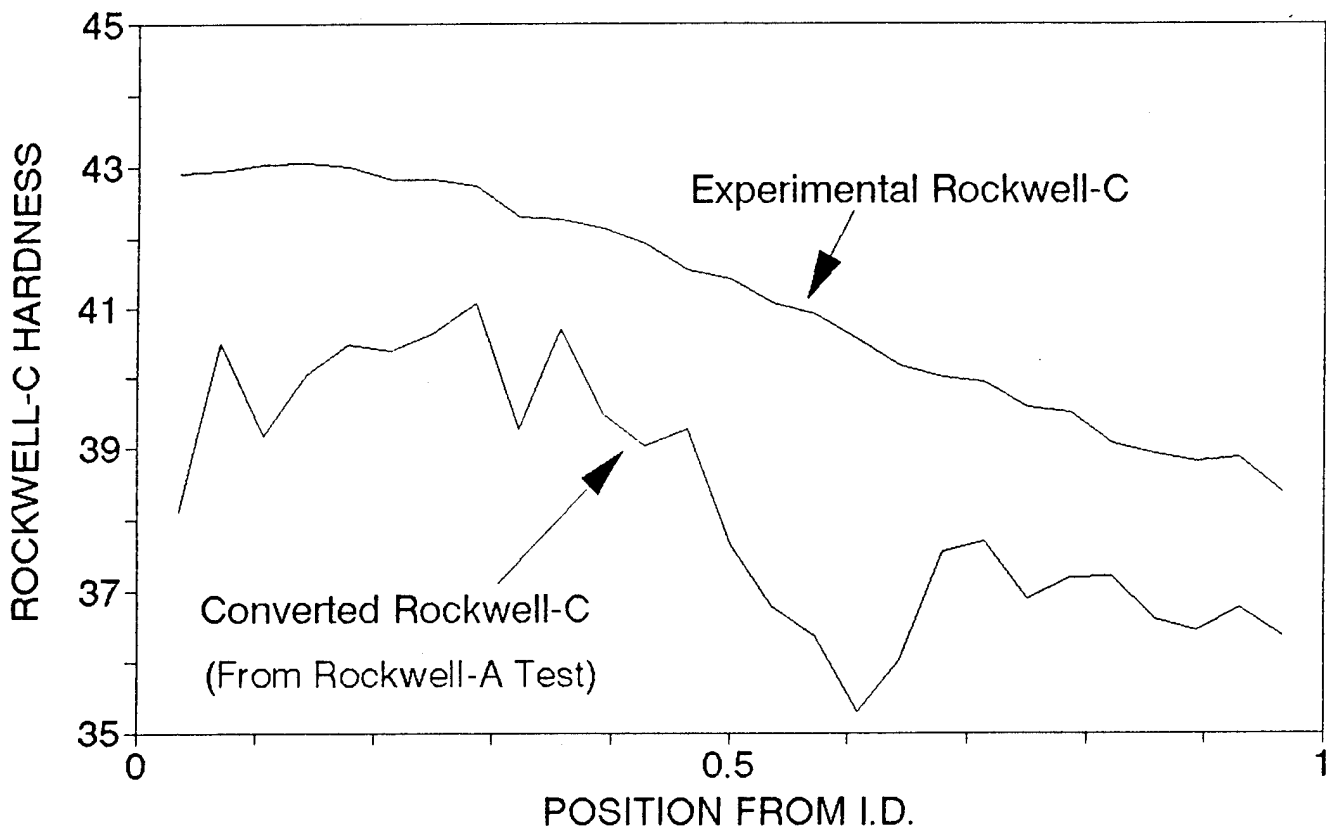

Figure 15. The converted Rockwell-C hardness measurements along with the experimentally-measured Rockwell-C hardness measurements plotted as a function of R. The solid line represents the experimentally-measured Rockwell-C hardness values and the dotted line represents the converted Rockwell-C hardness values.

FIGURE # 16

ROCKWELL C AND D HARDNESS OF SAMPLE G

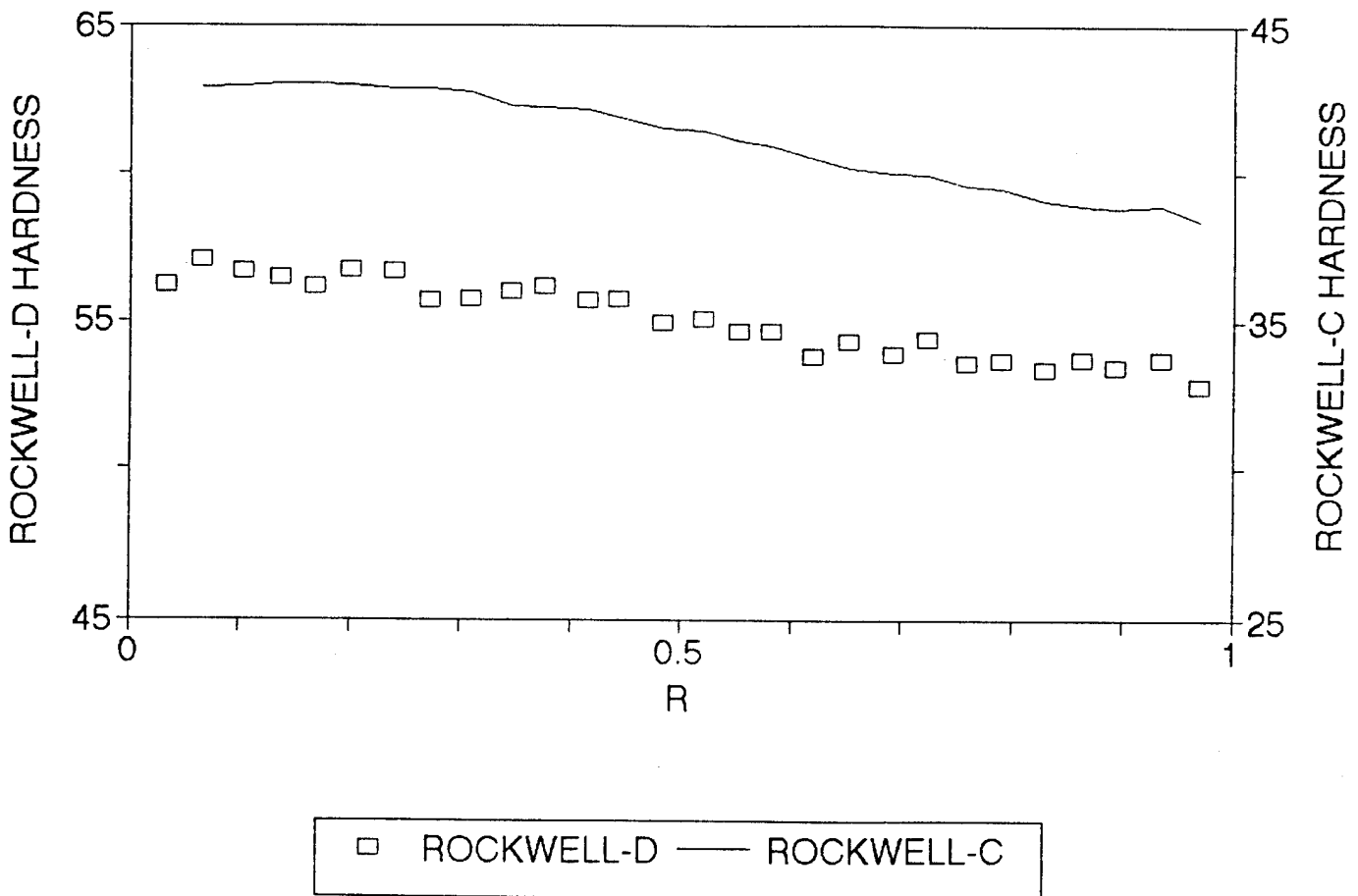

Figure 16. The experimentally-measured Rockwell-D and C hardness plotted as a function of R. The solid line represents the experimentally-measured Rockwell-C hardness values the open square represents the experimentally-measured Rockwell-D hardness values.

TECHNICAL REPORT INTERNAL DISTRIBUTION LIST

	<u>NO. OF COPIES</u>
CHIEF, DEVELOPMENT ENGINEERING DIVISION	
ATTN: AMSTA-AR-CCB-DA	1
-DB	1
-DC	1
-DD	1
-DE	1
 CHIEF, ENGINEERING DIVISION	
ATTN: AMSTA-AR-CCB-E	1
-EA	1
-EB	1
-EC	
 CHIEF, TECHNOLOGY DIVISION	
ATTN: AMSTA-AR-CCB-T	2
-TA	1
-TB	1
-TC	1
 TECHNICAL LIBRARY	
ATTN: AMSTA-AR-CCB-O	5
 TECHNICAL PUBLICATIONS & EDITING SECTION	
ATTN: AMSTA-AR-CCB-O	3
 OPERATIONS DIRECTORATE	
ATTN: SMCWV-ODP-P	1
 DIRECTOR, PROCUREMENT & CONTRACTING DIRECTORATE	
ATTN: SMCWV-PP	1
 DIRECTOR, PRODUCT ASSURANCE & TEST DIRECTORATE	
ATTN: SMCWV-QA	1

NOTE: PLEASE NOTIFY DIRECTOR, BENÉT LABORATORIES, ATTN: AMSTA-AR-CCB-O OF ADDRESS CHANGES.

TECHNICAL REPORT EXTERNAL DISTRIBUTION LIST

	<u>NO. OF COPIES</u>		<u>NO. OF COPIES</u>
ASST SEC OF THE ARMY RESEARCH AND DEVELOPMENT ATTN: DEPT FOR SCI AND TECH THE PENTAGON WASHINGTON, D.C. 20310-0103	1	COMMANDER ROCK ISLAND ARSENAL ATTN: SMCRI-ENM ROCK ISLAND, IL 61299-5000	1
ADMINISTRATOR DEFENSE TECHNICAL INFO CENTER ATTN: DTIC-OCP (ACQUISITION GROUP) BLDG. 5, CAMERON STATION ALEXANDRIA, VA 22304-6145	2	MIAC/CINDAS PURDUE UNIVERSITY P.O. BOX 2634 WEST LAFAYETTE, IN 47906	1
COMMANDER U.S. ARMY ARDEC ATTN: SMCAR-AEE	1	COMMANDER U.S. ARMY TANK-AUTMV R&D COMMAND ATTN: AMSTA-DDL (TECH LIBRARY) WARREN, MI 48397-5000	1
SMCAR-AES, BLDG. 321	1	COMMANDER	
SMCAR-AET-O, BLDG. 351N	1	U.S. MILITARY ACADEMY	
SMCAR-FSA	1	ATTN: DEPARTMENT OF MECHANICS	1
SMCAR-FSM-E	1	WEST POINT, NY 10966-1792	
SMCAR-FSS-D, BLDG. 94	1		
SMCAR-IMI-I, (STINFO) BLDG. 59	2	U.S. ARMY MISSILE COMMAND	
PICATINNY ARSENAL, NJ 07806-5000		REDSTONE SCIENTIFIC INFO CENTER	2
		ATTN: DOCUMENTS SECTION, BLDG. 4484	
		REDSTONE ARSENAL, AL 35898-5241	
DIRECTOR U.S. ARMY RESEARCH LABORATORY ATTN: AMSRL-DD-T, BLDG. 305 ABERDEEN PROVING GROUND, MD 21005-5066	1	COMMANDER U.S. ARMY FOREIGN SCI & TECH CENTER ATTN: DRXST-SD 220 7TH STREET, N.E. CHARLOTTESVILLE, VA 22901	1
DIRECTOR U.S. ARMY RESEARCH LABORATORY ATTN: AMSRL-WT-PD (DR. B. BURNS) ABERDEEN PROVING GROUND, MD 21005-5066	1	COMMANDER U.S. ARMY LABCOM MATERIALS TECHNOLOGY LABORATORY ATTN: SLCMT-IML (TECH LIBRARY) WATERTOWN, MA 02172-0001	2
DIRECTOR U.S. MATERIEL SYSTEMS ANALYSIS ACTV ATTN: AMXSY-MP ABERDEEN PROVING GROUND, MD 21005-5071	1	COMMANDER U.S. ARMY LABCOM, ISA ATTN: SLCIS-IM-TL 2800 POWER MILL ROAD ADELPHI, MD 20783-1145	1

NOTE: PLEASE NOTIFY COMMANDER, ARMAMENT RESEARCH, DEVELOPMENT, AND ENGINEERING CENTER,
BENÉT LABORATORIES, CCAC, U.S. ARMY TANK-AUTOMOTIVE AND ARMAMENTS COMMAND,
AMSTA-AR-CCB-O, WATERVLIT, NY 12189-4050 OF ADDRESS CHANGES.

TECHNICAL REPORT EXTERNAL DISTRIBUTION LIST (CONT'D)

	<u>NO. OF COPIES</u>		<u>NO. OF COPIES</u>
COMMANDER U.S. ARMY RESEARCH OFFICE ATTN: CHIEF, IPO P.O. BOX 12211 RESEARCH TRIANGLE PARK, NC 27709-2211	1	WRIGHT LABORATORY ARMAMENT DIRECTORATE ATTN: WL/MNM EGLIN AFB, FL 32542-6810	1
DIRECTOR U.S. NAVAL RESEARCH LABORATORY ATTN: MATERIALS SCI & TECH DIV CODE 26-27 (DOC LIBRARY) WASHINGTON, D.C. 20375	1 1	WRIGHT LABORATORY ARMAMENT DIRECTORATE ATTN: WL/MNMF EGLIN AFB, FL 32542-6810	1

NOTE: PLEASE NOTIFY COMMANDER, ARMAMENT RESEARCH, DEVELOPMENT, AND ENGINEERING CENTER,
BENÉT LABORATORIES, CCAC, U.S. ARMY TANK-AUTOMOTIVE AND ARMAMENTS COMMAND,
AMSTA-AR-CCB-O, WATERVLIET, NY 12189-4050 OF ADDRESS CHANGES.

DEPARTMENT OF THE ARMY

ARMAMENT RESEARCH, DEVELOPMENT AND ENGINEERING CENTER
BENÉT LABORATORIES, CCAC
US ARMY TANK-AUTOMOTIVE AND ARMAMENTS COMMAND
WATERVLIET, N.Y. 12189-4050

OFFICIAL BUSINESS

AMSTA-AR-CCB-O
TECHNICAL LIBRARY

DEPARTMENT OF THE ARMY

OFFICIAL BUSINESS

ADMINISTRATOR
DEFENSE TECHNICAL INFO CENTER
ATTN: DTIC-OCF (ACQUISITION GROUP)
BLDG. 5, CAMERON STATION
ALEXANDRIA, VA 22304-6145

DA Label 18-1, Sep 83
Edition of Oct 74 will be used until exhausted.