

DTIC
SELECTED
DEC 27 1995
F

**United States Air Force
611 Air Support Group
611 Civil Engineer Squadron**

Elmendorf AFB, Alaska

FINAL

Indian Mountain LRRS, Alaska

**CONSTRUCTION REPORT FOR
INTERIM REMEDIAL ACTION AND
TREATABILITY STUDY**

DISTRIBUTION STATEMENT A
Approved for public release
Distribution Unlimited

*Original contains color
plates. All DTIC reproductions
will be in black and
white*

DECEMBER 1995

1995 12 15 084

DISCLAIMER NOTICE



THIS DOCUMENT IS BEST QUALITY AVAILABLE. THE COPY FURNISHED TO DTIC CONTAINED A SIGNIFICANT NUMBER OF PAGES WHICH DO NOT REPRODUCE LEGIBLY.

**United States Air Force
611 Air Support Group
611 Civil Engineer Squadron**

Elmendorf AFB, Alaska

FINAL

Indian Mountain LRRS, Alaska

CONSTRUCTION REPORT FOR
INTERIM REMEDIAL ACTION AND
TREATABILITY STUDY

DECEMBER 1995

By:



JACOBS ENGINEERING GROUP INC.

600 17th Street, Suite 1100N

Denver, CO 80202

19951215 084

NOTICE

This report has been prepared for the U.S. Air Force by Jacobs Engineering Group Inc. to aid in the implementation of Interim Remedial Actions under the Air Force Installation Restoration Program (IRP). Because the report relates to actual or possible releases of potentially hazardous substances, its dissemination before an Air Force final decision on remedial action may be in the public's best interest. It is important to note the limited objectives of this report and the ongoing nature of the IRP, along with the evolving knowledge of site conditions and chemical effects on human health and the environment, because subsequent facts may become known that make this report premature or inaccurate. Acceptance does not mean the U.S. Air Force adopts the conclusions, recommendations, or other views expressed herein, which are those of the contractor only and do not necessarily reflect the official position of the U.S. Air Force.

Government agencies and their subcontractors registered with the Defense Technical Information Center (DTIC) should direct requests for copies of this report to: DTIC, 8725 John J. Kingman Road, Fort Belvoir, Virginia 22060.

Nongovernment agencies may purchase copies of this document from: National Technical Information Service (NTIS), 6285 Port Royal Road, Springfield, Virginia 22161.

Accession For		
NTIS	CRA&I	<input checked="" type="checkbox"/>
DTIC	TAB	<input type="checkbox"/>
Unannounced		<input type="checkbox"/>
Justification		
By		
Distribution /		
Availability Codes		
Dist	Avail and/or Special	
A-1		

(intentionally blank)

REPORT DOCUMENTATION PAGE				Form Approved OMB No. 0704-0188	
1a. REPORT SECURITY CLASSIFICATION Unclassified		1b. RESTRICTIVE MARKINGS Not Applicable			
2a. SECURITY CLASSIFICATION AUTHORITY Not Applicable		3. DISTRIBUTION/AVAILABILITY OF REPORT Not Applicable			
2b. DECLASSIFICATION/DOWNGRADING SCHEDULE Not Applicable					
4. PERFORMING ORGANIZATION REPORT NUMBER(S) Not Applicable		5. MONITORING ORGANIZATION REPORT NUMBER(S) Not Applicable			
6a. NAME OF PERFORMING ORGANIZATION Jacobs Engineering Group Inc.		6b. OFFICE SYMBOL (if applicable)	7a. NAME OF MONITORING ORGANIZATION Air Force Center for Environmental Excellence		
6c. ADDRESS (City, State, and Zip Code) 600 17th Street, Suite 1100N, Denver, CO 80202		7b. ADDRESS (City, State, and Zip Code) Brooks Air Force Base, TX 78235-5363			
8a. NAME OF FUNDING/SPONSORING ORGANIZATION Air Force Center for Environmental Excellence		8b. OFFICE SYMBOL (if applicable) AFCEE/ERD	9. PROCUREMENT INSTRUMENT IDENTIFICATION NUMBER USAF Contract No. F41624-94-D-8046-0004		
9c. ADDRESS (City, State, and Zip Code) Brooks AFB, TX 78235-5363		10. SOURCE OF FUNDING NUMBERS			
		PROGRAM ELEMENT NO. N/A	PROJECT NO. N/A	TASK NO. N/A	WORK UNIT ACCESSION NO. N/A
11. TITLE (Include Security Classification) Installation Restoration Program, Construction Report for Interim Remedial Action and Treatability Study for Indian Mountain Long Range Radar Station, Alaska					
12. PERSONAL AUTHOR(S) Jacobs Engineering Group Inc.					
13a. TYPE OF REPORT Final	13b. TIME COVERED FROM 1 August 1995 TO 08 December 1995		14. DATE OF REPORT (Year, Month, Day) 11 December 1995		15. PAGE COUNT
16. SUPPLEMENTARY NOTATION Not Applicable					
17. COSATI CODES			18. SUBJECT TERMS (Continue on reverse if necessary and identify by block number) Interim Remedial Action, Diversion Ditch, Containment Cell, Treatability Study, Investigation-Derived Waste		
FIELD	GROUP	SUB-GROUP			
19. ABSTRACT (Continue on reverse if necessary and identify by block number) This Final Construction Report is provided under Contract No. F41624-94-D-8046-0004, between the U.S. Air Force and Jacobs Engineering Group Inc. The purpose of this report is to describe and detail the activities conducted as part of the Interim Remedial Action and Treatability Study at Indian Mountain Long Range Radar Station, Alaska. This report contains five sections. Section 1.0 provides introduction and background information, and describes general tasks completed. Section 2.0 describes the construction activities. Section 3.0 presents the environmental sampling results and data evaluation for the two tasks. Conclusions and final recommendations are in Section 4.0. Section 5.0 lists references cited in the report.					
20. DISTRIBUTION/AVAILABILITY OF ABSTRACT [x] Unclassified/Unlimited [] Same as RPT. [] DTIC Users			21. ABSTRACT SECURITY CLASSIFICATION Unclassified		
22a. NAME OF RESPONSIBLE INDIVIDUAL Samer Karmi		22b. TELEPHONE (Include Area Code) (210) 536-5297		22c. OFFICE SYMBOL AFCEE/ERD	

(intentionally blank)

PREFACE

This report describes several tasks completed in 1995 at Indian Mountain Long Range Radar Station, Alaska. An interim remedial action was completed, a treatability study containment cell was constructed, and investigation-derived waste was managed. This work was performed in accordance with the requirements of Contract No. F41624-94-D-8046, Delivery Order No. 0004, between the U.S. Air Force and Jacobs Engineering Group Inc.

The Jacobs Engineering Group Inc. Project Manager for this delivery order is Ms. Sarah Brown. Mr. Samer Karmi of the Air Force Center for Environmental Excellence is the Alaska Restoration Team Chief for this task.

Approved:

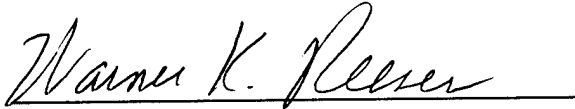

Warner K. Reeser
Program Manager
Jacobs Engineering Group Inc.

(intentionally blank)

TABLE OF CONTENTS

<u>Section</u>	<u>Page</u>
ACRONYMS AND ABBREVIATIONS	ix
1.0 INTRODUCTION.....	1
1.1 Interim Remedial Action	1
1.2 Treatability Study - Investigation-Derived Waste Management.....	2
2.0 CONSTRUCTION ACTIVITIES.....	3
2.1 Diversion Ditch Construction.....	3
2.2 Containment Cell Construction	8
3.0 SAMPLING, ANALYSIS AND DATA EVALUATION.....	11
3.1 Diversion Ditch.....	11
3.2 Containment Cell	14
4.0 CONCLUSIONS	33
5.0 REFERENCES.....	35
<u>List of Figures</u>	
Figure 2.1-1 As-Built of Diversion Ditch Plan View OT08.....	4
Figure 2.1-2 As-Built of Diversion Ditch and Sampling Port Cross Section OT08	5
Figure 2.2-1 Containment Cell Location.....	9
Figure 2.2-2 As-Built of Containment Cell - Plan View	12
Figure 2.2-3 As-Built of Containment Cell - Cross Sectional Views	13
<u>List of Tables</u>	
Table 2.1-1 Geotechnical Results OT08 - Diversion Ditch.....	7
Table 3.1-1 Laboratory Analytical Results Diversion Ditch	15
Table 3.2-1 Laboratory Analytical Results Containment Cell and Investigation-Derived Waste Drums	20
Table 3.2-2 Mean Analyte Concentrations Containment Cell and Investigation- Derived Waste Drums	27
Table 3.2-3 1994 Background Levels of Metals	29
<u>Appendix</u>	
Appendix A OT08 Test Pit Field Sampling Forms	

(intentionally blank)

ACRONYMS

ADEC	Alaska Department of Environmental Conservation
bgs	below ground surface
CERCLA	Comprehensive Environmental Response, Compensation, and Liability Act of 1980
CO ₂	carbon dioxide
DRO	diesel range organic compounds
EPA	Environmental Protection Agency
F	Fahrenheit
GRO	gasoline range organic compounds
HDPE	high-density polyethylene
ID	inside diameter
IDW	investigation-derived waste
IRA	Interim Remedial Action
Jacobs	Jacobs Engineering Group Inc.
LRRS	Long Range Radar Station
mg/L	milligrams per liter
O ₂	oxygen
OD	outside diameter
PCB	polychlorinated biphenyl
ppm	parts per million
RI/FS	Remedial Investigation/Feasibility Study
SAP	Sampling and Analysis Plan
SVOC	semivolatile organic compound
TCLP	Toxicity Characteristic Leaching Procedure
µg/L	micrograms per liter
UST	underground storage tank
UTL	upper tolerance limit
VOC	volatile organic compound
WACS	White Alice Communications System
°	degree

(intentionally blank)

1.0 INTRODUCTION

During the summer of 1995, two construction tasks were conducted at Indian Mountain Long Range Radar Station (LRRS). This work was completed under the U.S. Air Force (Air Force) Installation Restoration Program (IRP). Additional IRP source area sampling was also performed and is described in a separate report. The original design and sampling approach for these tasks was described in the Work Plan and Sampling and Analysis Plan (SAP) for Interim Remedial Actions (Air Force 1995a). The construction tasks included excavation of a water diversion ditch as an interim remedial action (IRA). Also, a biotreatment cell was constructed to conduct a treatability study of contaminated soils excavated during 1994 sampling activities. This report describes the completion of these two construction tasks, analytical results from associated soil and water sampling, and conclusions based on observations and sampling results. The results and conclusions of the additional IRP source area sampling component of the plan are presented in a separate report, the Remedial Investigation/Feasibility Study (RI/FS) Report Addendum (Air Force 1995b).

1.1 Interim Remedial Action

Interim remedial actions are taken to contain contamination or prevent further migration of contaminants. In August 1995, an IRA was completed at source area OT08, the former White Alice Communications System (WACS) facility, located below the summit of Indian Mountain. The goal of the action was to prevent further migration of surface water and groundwater from source area SS10 into source area OT08. Water flowing from SS10 contains fuel from historical leaks and releases. Surface and subsurface soils at OT08 contain levels of polychlorinated biphenyls (PCBs) above the risk-based screening criteria. By diverting water flow around OT08 the amount of PCBs transported by erosion is reduced. In addition, the IRA was designed to dewater source area OT08 to simplify potential future PCB remediation.

The project involved excavating a diversion ditch along the west and north sides of OT08 to catch surface water and groundwater flowing down from the top of the mountain and source area SS10 and to divert the water around source area OT08. PCB results from 1994 were used to select a ditch location that would avoid PCB-contaminated soils. The ditch was lined with an impermeable and weatherproof material and backfilled. Descriptions of ditch construction, including as-built drawings, sampling activities, and analytical results, are presented in Sections 2.0 and 3.0.

1.2 Treatability Study - Investigation-Derived Waste Management

Treatability studies at Comprehensive Environmental Response, Compensation, and Liability Act (CERCLA) sites may be performed to achieve several different goals and may be undertaken during various stages of the process. At Indian Mountain LRRS, a treatability study was initiated to determine if a passive biotreatment process would reduce petroleum contamination levels in soil cuttings generated during site investigations. Such material is often referred to as investigation-derived waste (IDW). A containment cell designed for passive biotreatment of fuel-contaminated IDW was constructed during August 1995. The soils were generated during borehole drilling activities in 1994 and were characterized using petroleum hydrocarbon test kit and laboratory analyses. Laboratory analytes included fuel and fuel-related compounds, and metals. A detailed evaluation of IDW contamination was completed to determine soils disposition (Jacobs Engineering Group Inc. [Jacobs] 1995). The risk-based screening criteria compiled for the RI/FS risk evaluation were also used for IDW characterization. The contaminants expected to be biodegraded are organic compounds commonly found in diesel fuel and gasoline. Cell construction and sampling activities performed after cell completion are described below.

2.0 CONSTRUCTION ACTIVITIES

The following sections describe construction of a ditch to divert the flow of fuel-contaminated water from IRP source area SS10 into adjacent IRP source area OT08, and a biotreatment containment cell for IDW soils.

2.1 Diversion Ditch Construction

The ditch was constructed as described in the Work Plan and SAP Addendum (Air Force 1995a). Station personnel determined that the excavation area was clear of utility lines. Station records and maps were reviewed to clear the area. A backhoe was used to excavate the ditch around the western and northern edges of source area OT08. The ditch is 199 feet long (Figure 2.1-1). The ditch was planned, using map information, to be 300 to 500 feet long. Field observations made before ditch excavation, including the utility clearance, resulted in changing the location and length of the ditch. These changes should not compromise the original objective of water diversion around source area OT08.

The ditch was excavated in short segments starting at the western end of the ditch. After excavating each section, a liner consisting of 30-mil high-density polyethylene (HDPE) (specifically XR-5) was lowered into the bottom of the ditch, and the ditch was backfilled with excavated soil. All removed soil material was left onsite. Most of the soil was used to backfill the trench. The remainder was used to construct the berm on the downgradient side of the ditch or was spread around the excavation area. An extension of the liner was draped up the downgradient side of the ditch and over backfilled material within the ditch and anchored with soil (Figure 2.1-2). Several small, unlined excavations were made at the eastern terminus of the ditch to allow water flow into subsurface soil.

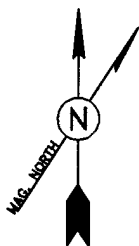
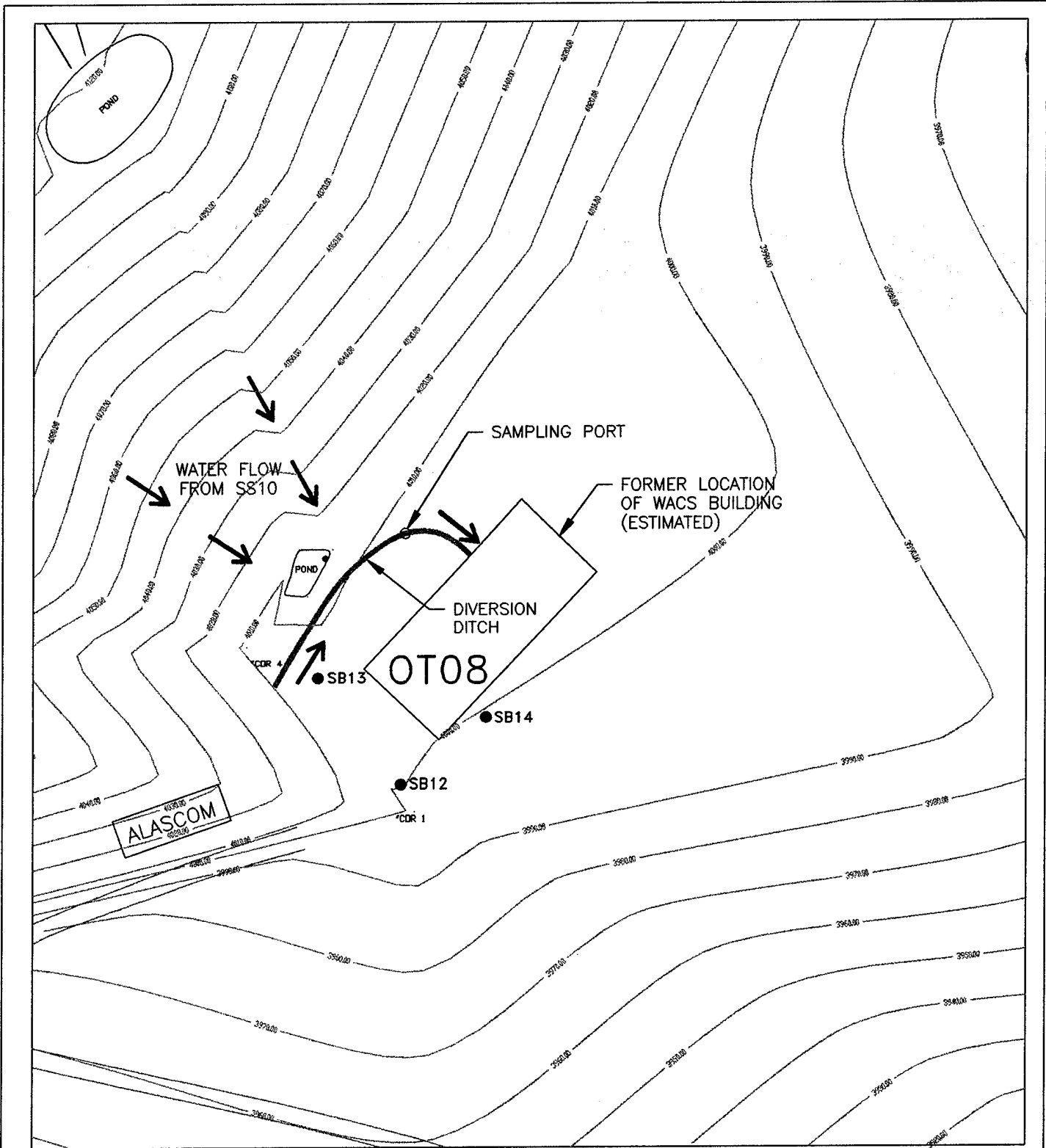

MAGNETIC DECLINATION : 24° 42'
 ANNUAL RATE OF CHANGE : 4.1'
 U.S.G.S. EPOCH 1985

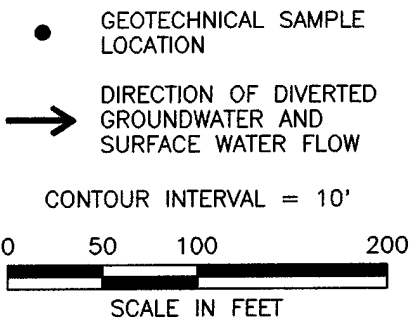

**INDIAN MOUNTAIN
 LONG RANGE RADAR STATION**

AS-BUILT OF DIVERSION DITCH
 PLAN VIEW OT08

PROJ. MGR. S. BROWN	ACAD FILE NO. 2_1-1	FIGURE NO. 2.1-1
DRAWN BY J. HUNTER	PROJ. NO. 05-G-46200	DATE 10/12/95

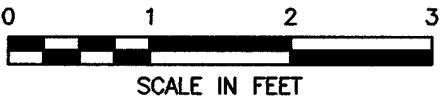
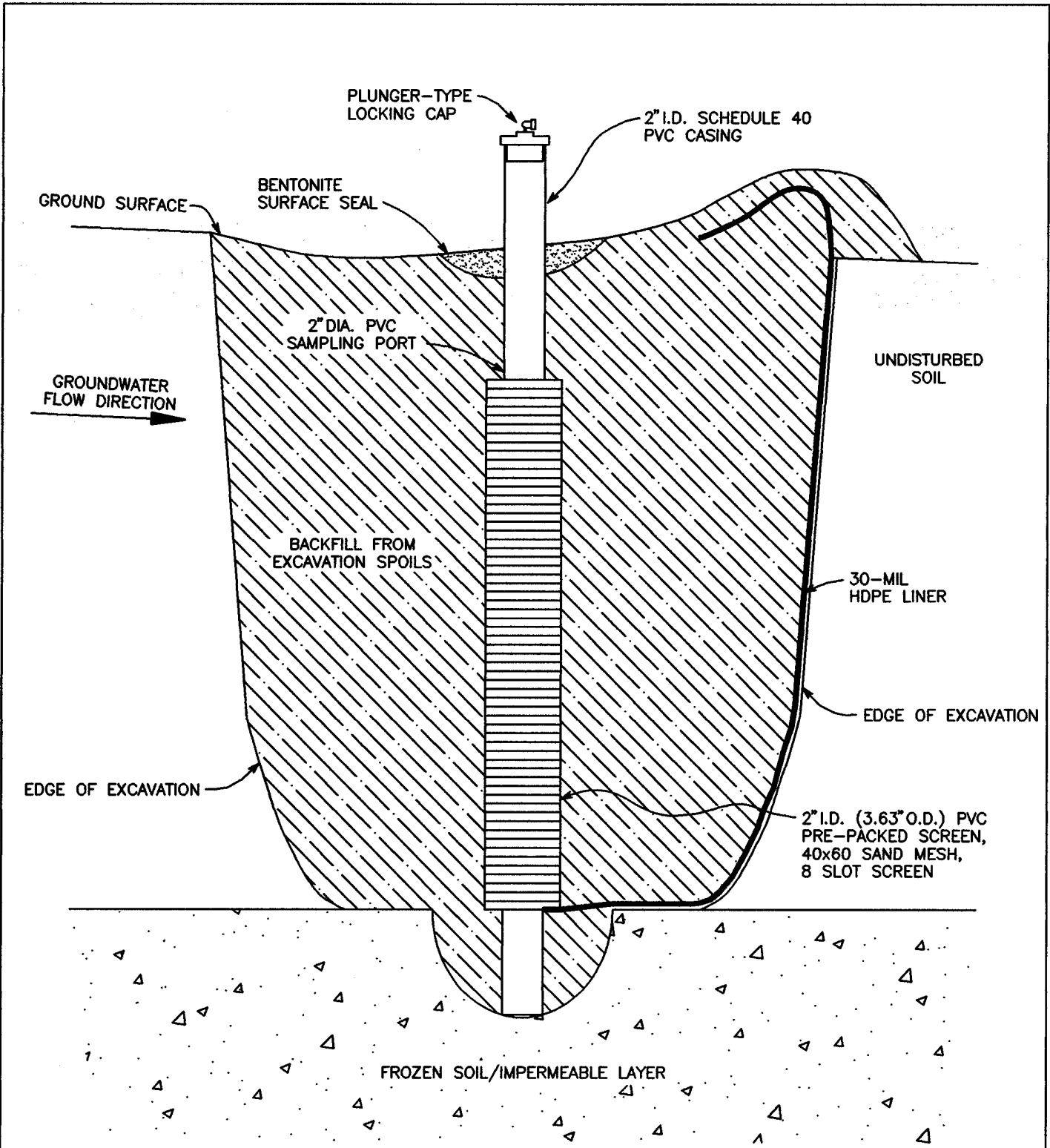



**INDIAN MOUNTAIN
LONG RANGE RADAR STATION**

AS-BUILT OF DIVERSION DITCH
AND SAMPLING PORT
CROSS SECTION OT08

PROJ. MGR. S. BROWN	ACAD FILE NO. 2_1-2	FIGURE NO. 2.1-2
DRAWN BY J. HUNTER	PROJ. NO. 05-G-46200	DATE 10/12/95

Observations and soil sampling results suggest that subsurface soil along all but the last 25 feet of the ditch path is contaminated with diesel fuel. Soil sampling is described in Section 3.0. The average depth of the ditch is 4.73 feet below ground surface (bgs). The maximum and minimum depths are 5.91 and 3.56 feet bgs, respectively. The depth of excavation was dependent on the presence of permafrost. Permafrost was encountered throughout the length of the ditch. The presence of permafrost controlled the maximum depth of the ditch because the backhoe was not capable of excavating in frozen ground. Water was encountered in the ditch excavation from the upgradient end until the ditch curved to the southeast, about 100 feet from the beginning of the excavation (Figure 2.1-1). Depth to water varied from water flowing across the ground surface to approximately 2.5 feet bgs. Subsurface material consisted of disturbed soil and rocks or fill from demolition of the former WACS facility. The material ranged from silt to boulders in size. Conditions observed during ditch excavation were similar to those seen during test pit excavation and sampling for source area OT08. The OT08 sampling effort is described in the RI/FS Report Addendum (Air Force 1995b). The test pit field forms have been included in this report as Appendix A to provide greater detail about subsurface conditions in the vicinity of the ditch. OT08 test pit samples were also analyzed for several geotechnical parameters including the following: cation-exchange capacity, clay percent, percent moisture, permeability, particle size analysis/distribution, total organic carbon, and bulk density. The geotechnical sample results are considered representative of soil conditions within the ditch because the test pit locations are near the ditch (Figure 2.1-1) and similar, fill-type material was observed. The geotechnical results have been summarized in Table 2.1-1.

A prefabricated well (sampling port) was installed in a sump about two-thirds down the length of the ditch (Figure 2.1-1). The well consisted of a Johnson Wheelabrator V-pack screen 5 feet long and was constructed of Schedule 40 Johnson polyvinyl

TABLE 2.1-1
Geotechnical Results
OT08 - Diversion Ditch
Indian Mountain Long Range Radar Station

Sample Identification	Test Method	Analyte	Value	Mean Value *	Units	Detection Limit
SO-OT08-SB12	SW9081	CATION-EXCHANGE CAPACITY	32.00	32.33	MEQ/100G	5.0000
SO-OT08-SB12	SWD422	CLAY PERCENT	4.00	4.33	%	
SO-OT08-SB12	D2216	PERCENT MOISTURE	7.70	16.56	%	0.0000
SO-OT08-SB12	SWD5084	PERMEABILITY	3.4E-06	4.1E-06	CM/SEC	
SO-OT08-SB12	SWD422	SAND PERCENT	9.00	11.66	%	
SO-OT08-SB12	SWD422	SILT PERCENT	13.00	19.33	%	
SO-OT08-SB12	D2487	SOIL CLASSIFICATION	BSG	N/A	N/A	N/A
SO-OT08-SB12	D854	SPECIFIC GRAVITY	2.75	2.72	MG/KG	0.0000
SO-OT08-SB12	SW9060	TOTAL ORGANIC CARBON	480.00	476.66	MG/KG	22.0000
SO-OT08-SB13	SW9081	CATION-EXCHANGE CAPACITY	30.00	32.33	MEQ/100G	5.0000
SO-OT08-SB13	SWD422	CLAY PERCENT	4.00	4.33	%	
SO-OT08-SB13	D2216	PERCENT MOISTURE	26.00	16.56	%	0.0000
SO-OT08-SB13	SWD5084	PERMEABILITY	7.3E-07	4.1E-06	CM/SEC	
SO-OT08-SB13	SWD422	SAND PERCENT	11.00	11.66	%	
SO-OT08-SB13	SWD422	SILT PERCENT	14.00	19.33	%	
SO-OT08-SB13	D2487	SOIL CLASSIFICATION	BSG/S	N/A	N/A	N/A
SO-OT08-SB13	D854	SPECIFIC GRAVITY	2.72	2.72	MG/KG	0.0000
SO-OT08-SB13	SW9060	TOTAL ORGANIC CARBON	500.00	476.66	MG/KG	27.0000
SO-OT08-SB14	SW9081	CATION-EXCHANGE CAPACITY	35.00	32.33	MEQ/100G	5.0000
SO-OT08-SB14	SWD422	CLAY PERCENT	5.00	4.33	%	
SO-OT08-SB14	D2216	PERCENT MOISTURE	16.00	16.56	%	0.0000
SO-OT08-SB14	SWD5084	PERMEABILITY	NA	4.1E-06	CM/SEC	
SO-OT08-SB14	SWD422	SAND PERCENT	15.00	11.66	%	
SO-OT08-SB14	SWD422	SILT PERCENT	31.00	19.33	%	
SO-OT08-SB14	D2487	SOIL CLASSIFICATION	BSS/G	N/A	N/A	N/A
SO-OT08-SB14	D854	SPECIFIC GRAVITY	2.70	2.72	MG/KG	0.0000
SO-OT08-SB14	SW9060	TOTAL ORGANIC CARBON	450.00	476.66	MG/KG	10.0000

Notes:

* = mean concentration of all samples
 BSG = brown silty gravel
 BSG/S = brown silty gravel with sand
 BSS/G = brown silty sand with gravel

CM/SEC = centimeters per second
 N/A = not applicable
 MEQ/100G = milliequivalent weights per 100 grams
 MG/KG = milligrams per kilogram
 % = percent

chloride. Specifications for the well were included as an appendix to the Work Plan and SAP Addendum (Air Force 1995a). The well was fitted with a locking well cap and locked. The liner material does not extend underneath the well, but the edge of the liner is against the downgradient side of the well (Figure 2.1-2).

2.2 Containment Cell Construction

Three potential cell locations were presented in the Work Plan and SAP Addendum (Air Force 1995a). The proposed Location No. 1 was selected and station personnel approved the area (Figure 2.2-1). The area was leveled with the backhoe and nearby soil and gravel were moved in to construct the cell berms. The XR-5 high-density polyethylene (HDPE) liner material was draped across the cell and berms. Ten of the 11 drums identified in the Work Plan and SAP Addendum (Air Force 1995a) were emptied into the containment cell. Drum 33 was not a soils drum but contained mixed liquid waste from 1994 test kit analyses; therefore, it was not added to the containment cell. Based on rapid turnaround laboratory results for volatile organic compounds (VOC) and metals analysis for the two drums (26 and 32) containing sediment from the 1994 decontamination area, these soils were also added to the containment cell. If the sediment contained elevated VOC and metals concentrations would have been held pending the TCLP results and disposition determined based on those data.

The soils to be treated were spread out across the cell and mixed slightly using a shovel. Several of the drums were not completely full, so the final volume of soil placed in the cell was approximately 2 cubic yards. The volume estimate used for the original cell design was 5 cubic yards. The dimensions of the cell, sump, and ventilation system were scaled down to accommodate the decreased soil volume.

LOWER CAMP

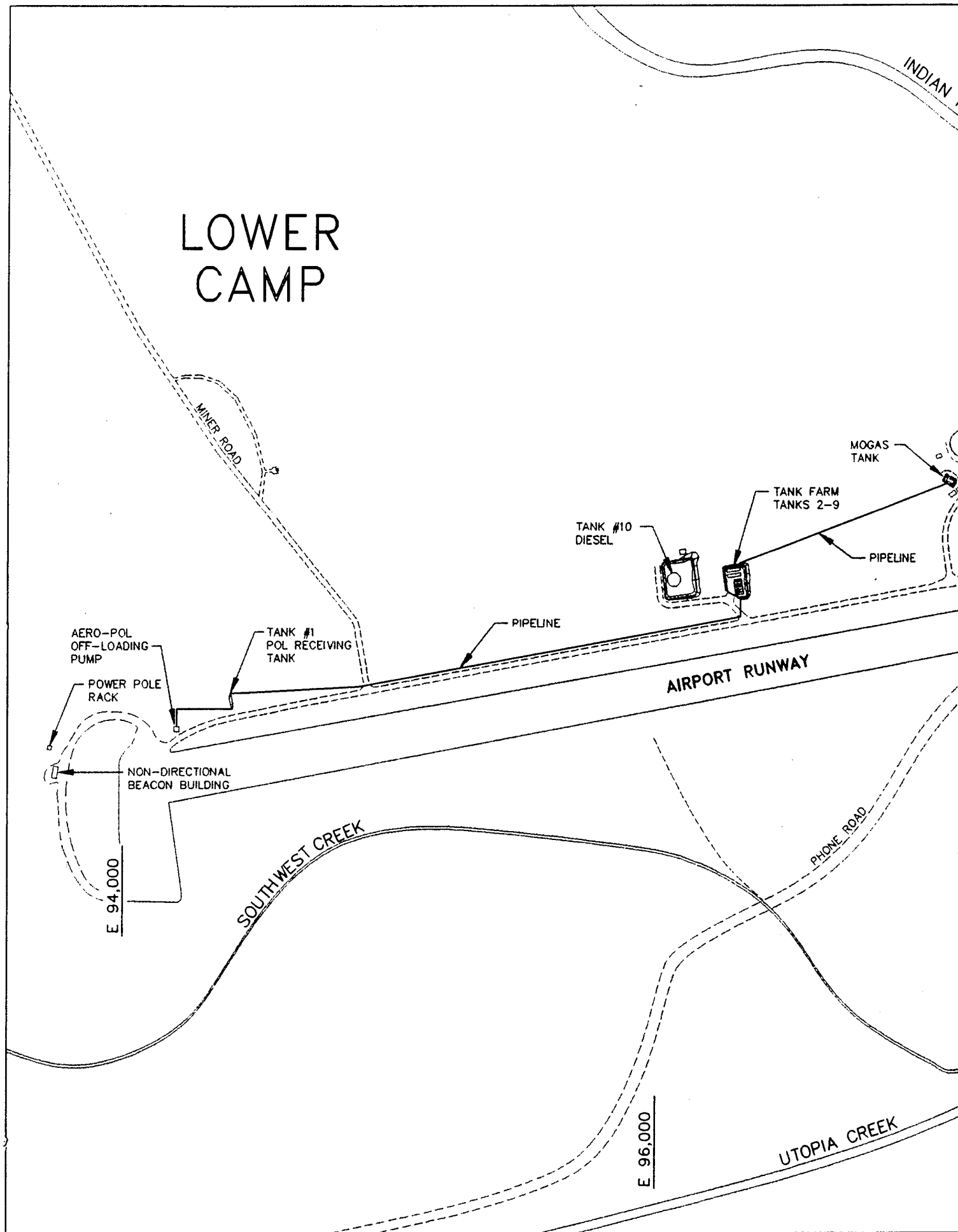

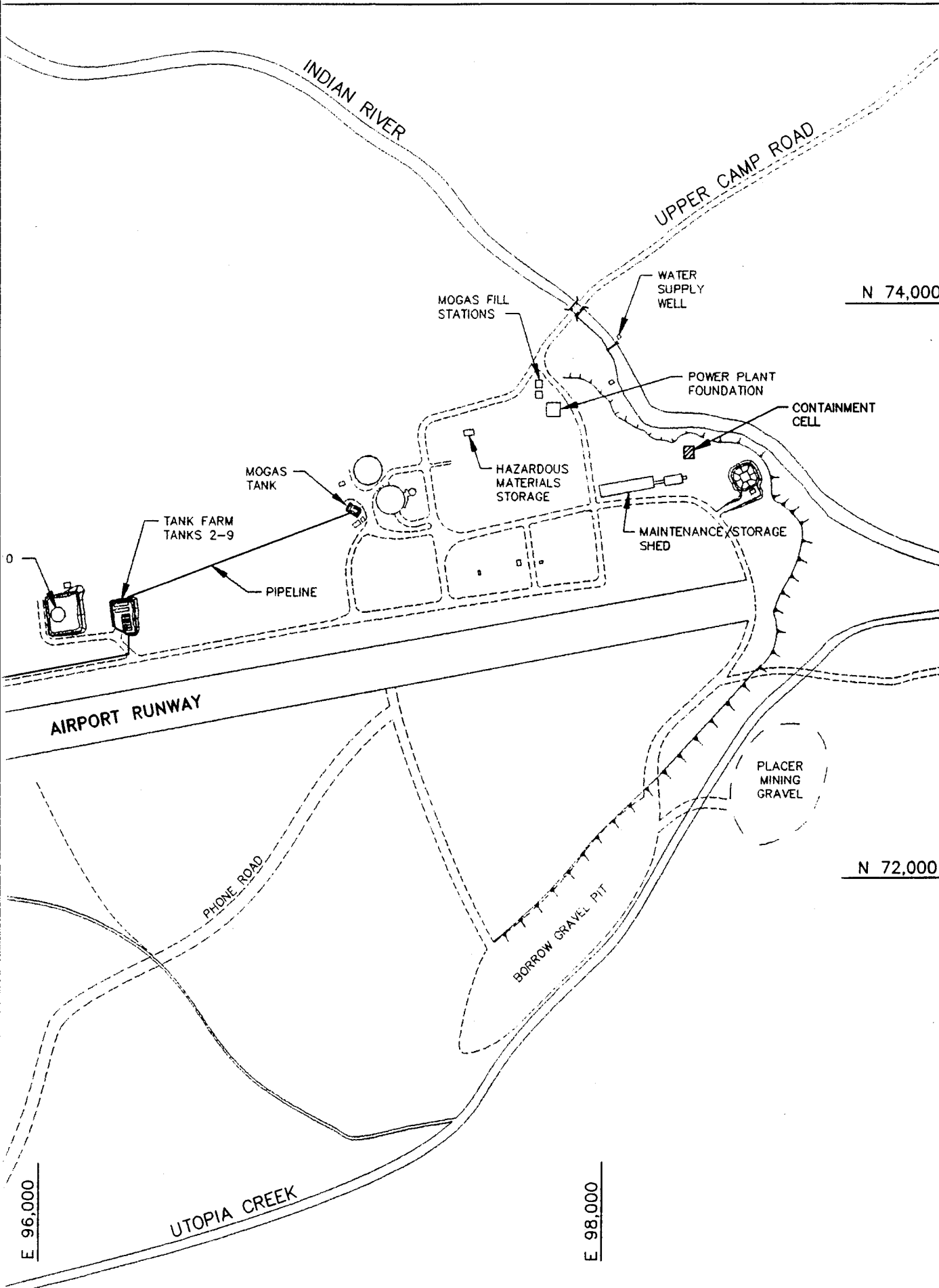

LEG





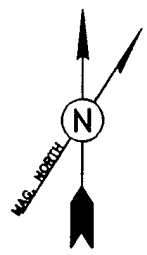
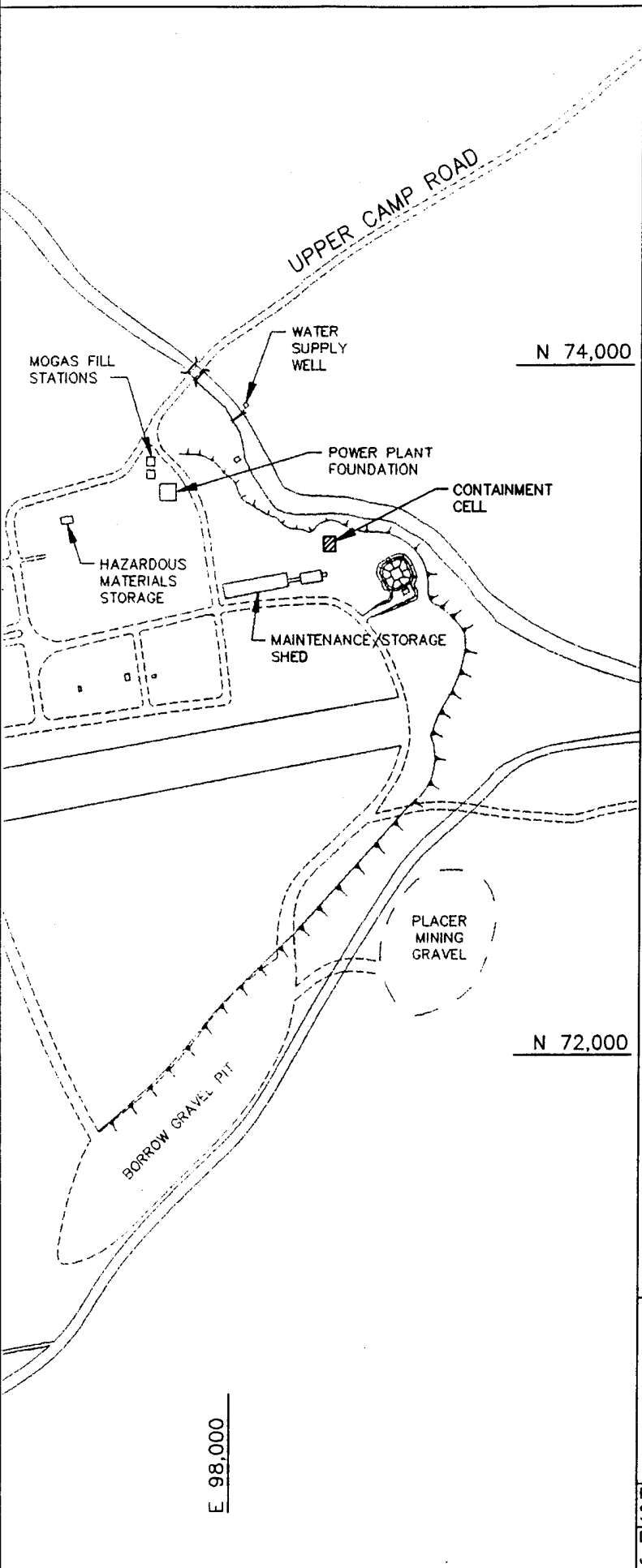

PROJ. MGR.	ACA
S. BROWN	2-
DRAWN BY	PRC
J. HUNTER	05

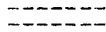

MAGNETIC DECLINATION : 24° 42'
 ANNUAL RATE OF CHANGE : 4.1"
 U.S.G.S. EPOCH 1985

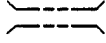
LEGEND

-  BUILDINGS
-  GRAVEL ROADS
-  RIVER, STREAM, OR CREEK
-  ESCARPMENT
-  CULVERT
-  CONTAINMENT CELL



**INDIAN MOUNTAIN
 LONG RANGE RADAR STATION**

CONTAINMENT CELL
 LOCATION

PROJ. MGR. S. BROWN	ACAD FILE NO. 2-1	FIGURE NO. 2.2-1
DRAWN BY J. HUNTER	PROJ. NO. 05-G-46200	DATE 10/13/95

Figures 2.2-2 and 2.2-3 depict the final construction details of the cell. As mentioned in the Work Plan and SAP Addendum (Air Force 1995a), those drums containing uncontaminated soils were emptied at the active station landfill. All drums were decontaminated and staged adjacent to the containment cell. Decontamination water was filtered using a carbon water conditioning unit and discharged into the station sewage treatment pond. Drum 33, containing liquid waste, and the used carbon filter drum were put on pallets inside the maintenance shed.

3.0 SAMPLING, ANALYSIS AND DATA EVALUATION

The following sections describe sampling and analysis performed during and after construction of the diversion ditch at OT08 and the containment cell at Lower Camp. Field test kit samples and samples collected for analytical laboratory analyses are described. Sample results are also presented. When appropriate, an evaluation of the results is provided.

3.1 Diversion Ditch

Immunoassay test kits designed for PCBs (U.S. Environmental Protection Agency [EPA] Method 4020) were used to ensure that PCB-contaminated soils were not present in soils where the ditch was excavated. Four samples collected from excavated soils were analyzed and no PCBs were detected. Test kit detection levels were 1, 10, and 40 parts per million (ppm).

Four petroleum hydrocarbon test kit samples (EPA Method 4030) were analyzed to estimate the presence and concentration of contamination in ditch soils. Four samples were analyzed, and all four samples contained petroleum fuels above the maximum detection level. Test kit sensitivities at the maximum detection level correspond to gasoline range organic compounds (GRO) at concentrations greater than 200 ppm and

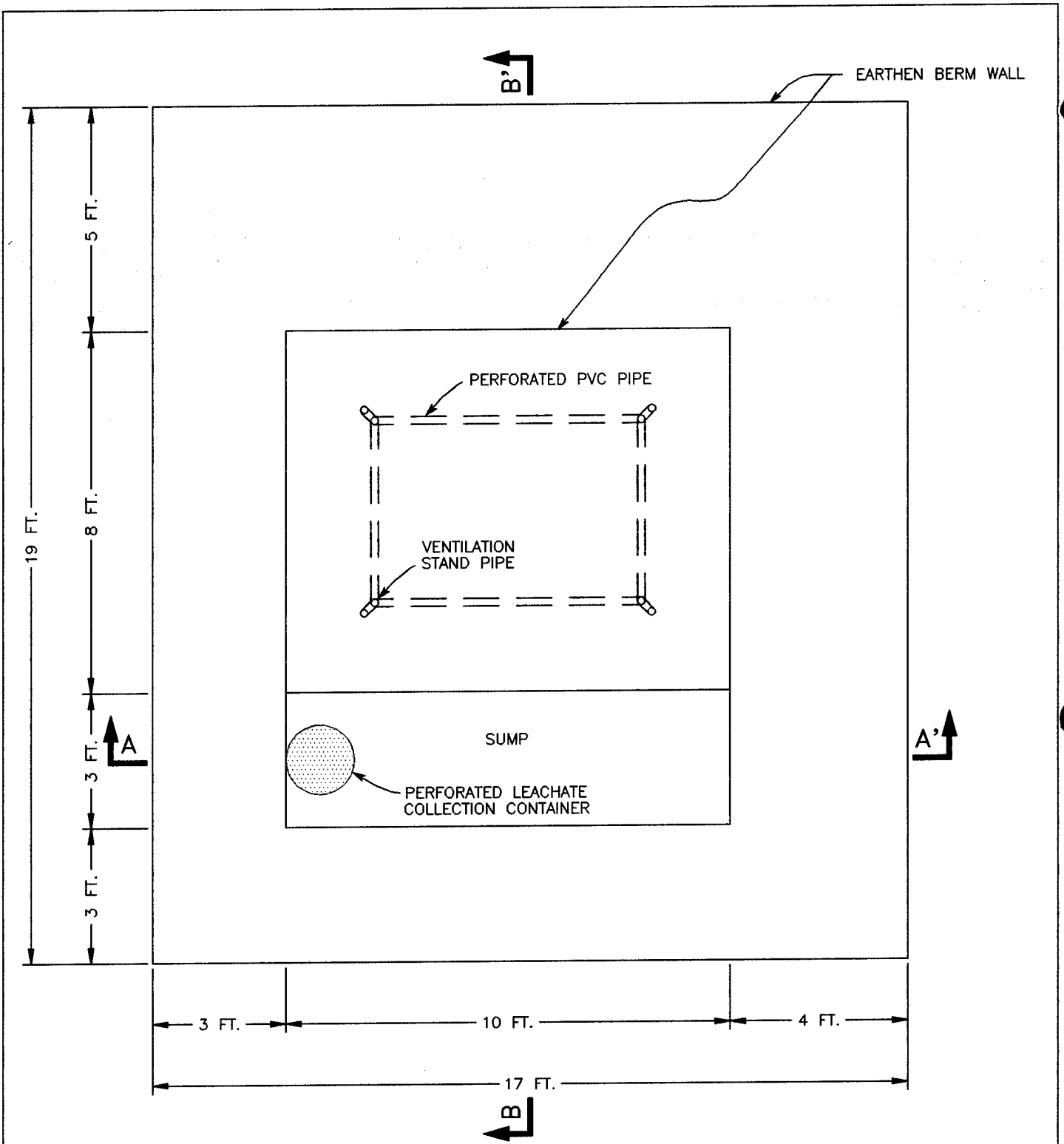

NOTE:
FOR CROSS SECTIONS, SEE
FIGURE NUMBER 2.2-3.

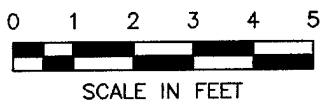



**INDIAN MOUNTAIN
LONG RANGE RADAR STATION**

AS-BUILT OF
CONTAINMENT CELL
PLAN VIEW

PROJ. MGR. S. BROWN	ACAD FILE NO. 3_1-2	FIGURE NO. 2.2-2
DRAWN BY J. HUNTER	PROJ. NO. 05-G-46200	DATE 10/13/95

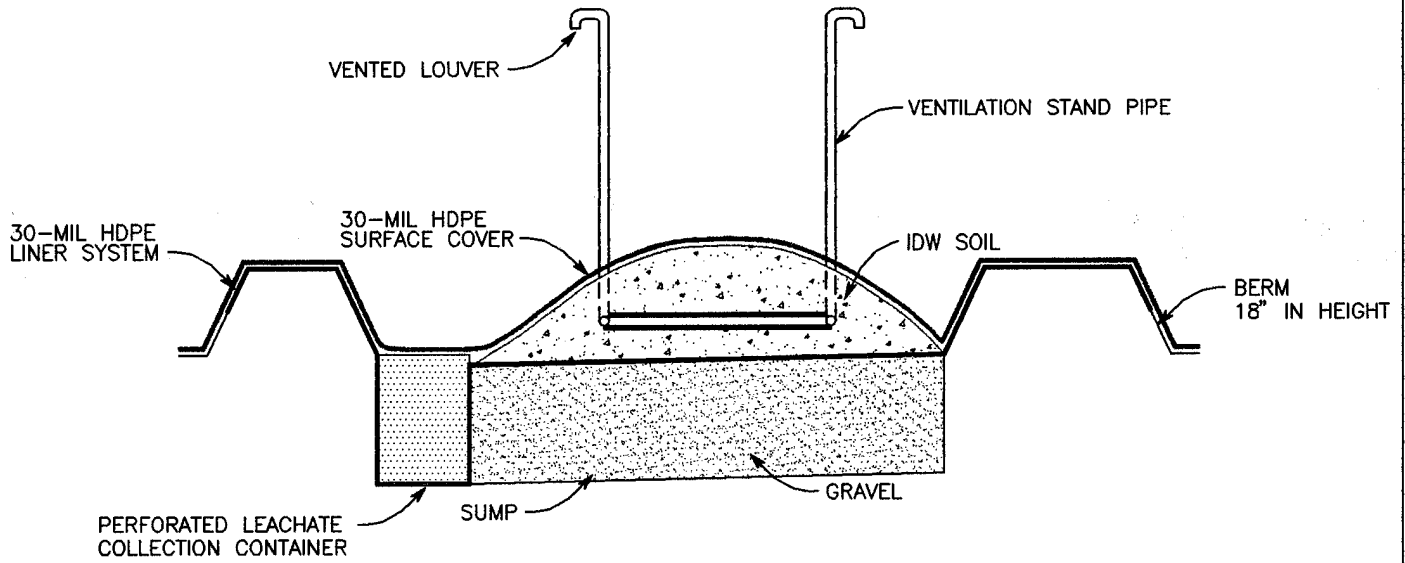

SECTION A-A'

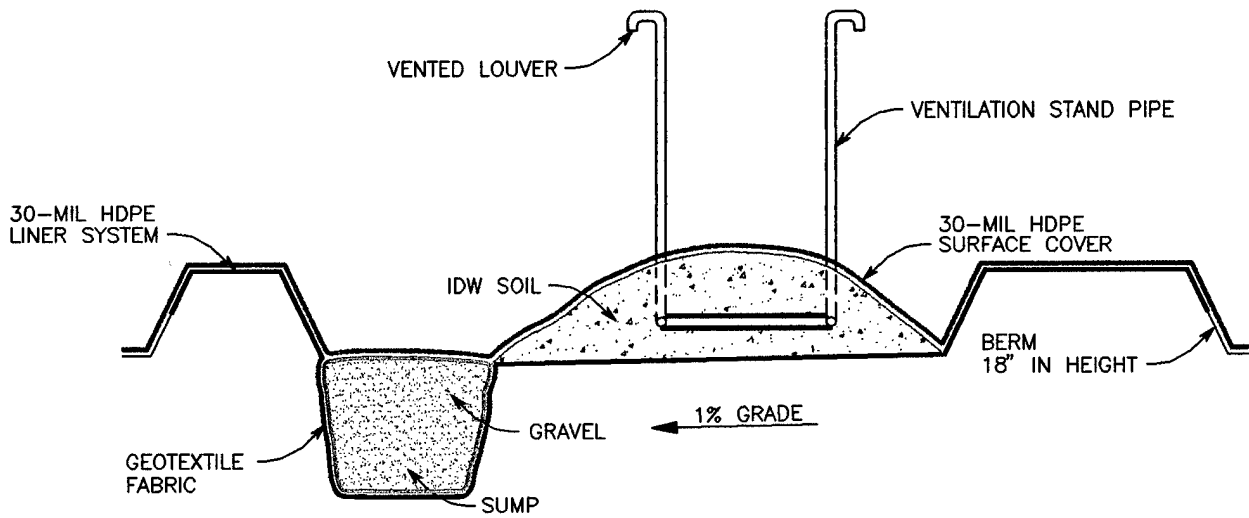

SECTION B-B'

NOTE:
FOR PLAN VIEW, SEE
FIGURE NUMBER 2.2-2.

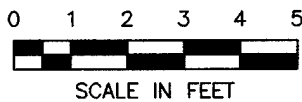

**INDIAN MOUNTAIN
LONG RANGE RADAR STATION**

AS-BUILT OF
CONTAINMENT CELL
CROSS SECTIONAL VIEWS

PROJ. MGR. S. BROWN	ACAD FILE NO. 3_1-3	FIGURE NO. 2.2-3
DRAWN BY J. HUNTER	PROJ. NO. 05-G-46200	DATE 10/13/95

greater than 300 ppm diesel range organic compounds (DRO). Specifications for the test kits were included in the Work Plan and SAP Addendum (Air Force 1995a).

Groundwater was collected from the well one day after the ditch was completed. The well was not purged before sampling because the volume of water in the well was small and recovery slow. Samples were submitted to the laboratory for VOC, semivolatile organic compound (SVOC), GRO, and DRO analyses.

GRO and DRO, measured using Methods AK101 and AK102, were detected in the ditch water collected from the well at 2.6 and 6.7 milligrams per liter (mg/L), respectively. Fluorene and bis(2-ethylhexyl) phthalate concentrations were estimated by the laboratory at 4.0 and 5.4 micrograms per liter ($\mu\text{g/L}$), respectively. No other compounds were detected in the ditch water sample. Table 3.1-1 includes a complete list of analyses and results. The difference between soil and water concentrations of DRO and GRO suggests that fuel contamination is bound to soil particles and is not readily dissolved and transported by water.

Geotechnical results from samples collected for source area OT08 characterization were presented in Table 2.1-1. Figure 2.1-1 shows the relative location of the test pits and diversion ditch.

3.2 Containment Cell

Sampling of the containment cell soils and two IDW drums was completed as proposed in the Work Plan and SAP Addendum (Air Force 1995a). Laboratory samples were collected from the drums using a stainless steel hand auger. Immunoassay test kit samples and laboratory samples were collected from the containment cell soils using the hand auger and a stainless steel spoon.

TABLE 3.1-1
Laboratory Analytical Results Diversion Ditch
Indian Mountain Long Range Radar Station

Matrix	Sample Identification	Test Method	Analyte	Value	Units	Detection Limit	Lab Qualifier
WG	WG-SS10-DD01	SW8260	1,1,1,2-TETRACHLOROETHANE	0.00	µg/L	0.2000	U
WG	WG-SS10-DD01	SW8260	1,1,1-TRICHLOROETHANE	0.00	µg/L	0.3000	U
WG	WG-SS10-DD01	SW8260	1,1,2,2-TETRACHLOROETHANE	0.00	µg/L	0.4000	U
WG	WG-SS10-DD01	SW8260	1,1,2-TRICHLOROETHANE	0.00	µg/L	0.4000	U
WG	WG-SS10-DD01	SW8260	1,1-DICHLOROETHANE	0.00	µg/L	0.2000	U
WG	WG-SS10-DD01	SW8260	1,1-DICHLOROETHENE	0.00	µg/L	0.4000	U
WG	WG-SS10-DD01	SW8270	1,2,4-TRICHLOROBENZENE	0.00	µg/L	4.0000	U
WG	WG-SS10-DD01	SW8260	1,2-DICHLOROBENZENE	0.00	µg/L	0.3000	U
WG	WG-SS10-DD01	SW8270	1,2-DICHLOROBENZENE	0.00	µg/L	4.0000	U
WG	WG-SS10-DD01	SW8260	1,2-DICHLOROETHANE	0.00	µg/L	0.3000	U
WG	WG-SS10-DD01	SW8260	1,2-DICHLOROPROPANE	0.00	µg/L	0.4000	U
WG	WG-SS10-DD01	SW8260	1,3-DICHLOROBENZENE	0.00	µg/L	0.3000	U
WG	WG-SS10-DD01	SW8270	1,3-DICHLOROBENZENE	0.00	µg/L	4.0000	U
WG	WG-SS10-DD01	SW8260	1,4-DICHLOROBENZENE	0.00	µg/L	0.2000	U
WG	WG-SS10-DD01	SW8270	1,4-DICHLOROBENZENE	0.00	µg/L	4.0000	U
WG	WG-SS10-DD01	SW8260	1-CHLOROHEXANE	0.00	µg/L	0.3000	U
WG	WG-SS10-DD01	SW8270	2,4,5-TRICHLOROPHENOL	0.00	µg/L	4.0000	U
WG	WG-SS10-DD01	SW8270	2,4,6-TRICHLOROPHENOL	0.00	µg/L	4.0000	U
WG	WG-SS10-DD01	SW8270	2,4-DICHLOROPHENOL	0.00	µg/L	4.0000	U
WG	WG-SS10-DD01	SW8270	2,4-DIMETHYLPHENOL	0.00	µg/L	4.0000	U
WG	WG-SS10-DD01	SW8270	2,4-DINITROPHENOL	0.00	µg/L	3.0000	U
WG	WG-SS10-DD01	SW8270	2,4-DINITROTOLUENE	0.00	µg/L	3.0000	U
WG	WG-SS10-DD01	SW8270	2,6-DINITROTOLUENE	0.00	µg/L	4.0000	U
WG	WG-SS10-DD01	SW8270	2-CHLORONAPHTHALENE	0.00	µg/L	6.0000	U
WG	WG-SS10-DD01	SW8270	2-CHLOROPHENOL	0.00	µg/L	4.0000	U
WG	WG-SS10-DD01	SW8270	2-METHYLNAPHTHALENE	0.00	µg/L	4.0000	U
WG	WG-SS10-DD01	SW8270	2-METHYLPHENOL (o-CRESOL)	0.00	µg/L	4.0000	U
WG	WG-SS10-DD01	SW8270	2-NITROANILINE	0.00	µg/L	4.0000	U
WG	WG-SS10-DD01	SW8270	2-NITROPHENOL	0.00	µg/L	5.0000	U
WG	WG-SS10-DD01	SW8270	3,3'-DICHLOROBENZIDINE	0.00	µg/L	3.0000	U
WG	WG-SS10-DD01	SW8270	3-NITROANILINE	0.00	µg/L	4.0000	U
WG	WG-SS10-DD01	SW8270	4,6-DINITRO-2-METHYLPHENOL	0.00	µg/L	5.0000	U

TABLE 3.1-1
Laboratory Analytical Results Diversion Ditch
Indian Mountain Long Range Radar Station

Matrix	Sample Identification	Test Method	Analyte	Value	Units	Detection Limit	Lab Qualifier
WG	WG-SS10-DD01	SW8270	4-BROMOPHENYL PHENYL ETHER	0.00	µg/L	3.0000	U
WG	WG-SS10-DD01	SW8270	4-CHLORO-3-METHYLPHENOL	0.00	µg/L	4.0000	U
WG	WG-SS10-DD01	SW8270	4-CHLOROANILINE	0.00	µg/L	5.0000	U
WG	WG-SS10-DD01	SW8270	4-CHLOROPHENYL PHENYL ETHER	0.00	µg/L	3.0000	U
WG	WG-SS10-DD01	SW8270	4-METHYLPHENOL (p-CRESOL)	0.00	µg/L	7.0000	U
WG	WG-SS10-DD01	SW8270	4-NITROANILINE	0.00	µg/L	4.0000	U
WG	WG-SS10-DD01	SW8270	4-NITROPHENOL	0.00	µg/L	3.0000	U
WG	WG-SS10-DD01	SW8270	ACENAPHTHENE	0.00	µg/L	3.0000	U
WG	WG-SS10-DD01	SW8270	ACENAPHTHYLENE	0.00	µg/L	4.0000	U
WG	WG-SS10-DD01	SW8270	ANTHRACENE	0.00	µg/L	3.0000	U
WG	WG-SS10-DD01	SW8260	BENZENE	0.00	µg/L	0.2000	U
WG	WG-SS10-DD01	SW8270	BENZO(a)ANTHRACENE	0.00	µg/L	2.0000	U
WG	WG-SS10-DD01	SW8270	BENZO(a)PYRENE	0.00	µg/L	2.0000	U
WG	WG-SS10-DD01	SW8270	BENZO(b)FLUORANTHENE	0.00	µg/L	2.0000	U
WG	WG-SS10-DD01	SW8270	BENZO(g,h,i)PERYLENE	0.00	µg/L	2.0000	U
WG	WG-SS10-DD01	SW8270	BENZO(k)FLUORANTHENE	0.00	µg/L	2.0000	U
WG	WG-SS10-DD01	SW8270	BENZOIC ACID	0.00	µg/L	30.0000	U
WG	WG-SS10-DD01	SW8270	BENZYL ALCOHOL	0.00	µg/L	4.0000	U
WG	WG-SS10-DD01	SW8270	BENZYL BUTYL PHTHALATE	0.00	µg/L	3.0000	U
WG	WG-SS10-DD01	SW8270	bis(2-CHLOROETHOXY) METHANE	0.00	µg/L	5.0000	U
WG	WG-SS10-DD01	SW8270	bis(2-CHLOROETHYL) ETHER (2-CHLOROETHYL ETHER)	0.00	µg/L	5.0000	U
WG	WG-SS10-DD01	SW8270	bis(2-CHLOROISOPROPYL) ETHER	0.00	µg/L	5.0000	U
WG	WG-SS10-DD01	SW8270	bis(2-ETHYLHEXYL) PHTHALATE	5.40	µg/L	3.0000	J
WG	WG-SS10-DD01	SW8260	BROMOBENZENE	0.00	µg/L	0.3000	U
WG	WG-SS10-DD01	SW8260	BROMODICHLOROMETHANE	0.00	µg/L	0.4000	U
WG	WG-SS10-DD01	SW8260	BROMOFORM	0.00	µg/L	0.4000	U
WG	WG-SS10-DD01	SW8260	BROMOMETHANE	0.00	µg/L	0.2000	U
WG	WG-SS10-DD01	SW8260	CARBON TETRACHLORIDE	0.00	µg/L	0.4000	U
WG	WG-SS10-DD01	SW8260	CHLOROBENZENE	0.00	µg/L	0.2000	U
WG	WG-SS10-DD01	SW8260	CHLOROETHANE	0.00	µg/L	0.5000	U
WG	WG-SS10-DD01	SW8260	CHLOROFORM	0.00	µg/L	0.3000	U
WG	WG-SS10-DD01	SW8260	CHLOROMETHANE	0.00	µg/L	0.4000	U

TABLE 3.1-1
Laboratory Analytical Results Diversion Ditch
Indian Mountain Long Range Radar Station

Matrix	Sample Identification	Test Method	Analyte	Value	Units	Detection Limit	Lab Qualifier
WG	WG-SS10-DD01	SW8270	CHRYSENE	0.00	µg/L	2.0000	U
WG	WG-SS10-DD01	SW8260	cis-1,2-DICHLOROETHYLENE	0.00	µg/L	0.3000	U
WG	WG-SS10-DD01	SW8270	Di-n-BUTYL PHTHALATE	0.00	µg/L	3.0000	U
WG	WG-SS10-DD01	SW8270	Di-n-OCTYLPHTHALATE	0.00	µg/L	2.0000	U
WG	WG-SS10-DD01	SW8270	DIBENZ(a,h)ANTHRACENE	0.00	µg/L	2.0000	U
WG	WG-SS10-DD01	SW8270	DIBENZOFURAN	0.00	µg/L	3.0000	U
WG	WG-SS10-DD01	SW8260	DIBROMOCHLOROMETHANE	0.00	µg/L	0.3000	U
WG	WG-SS10-DD01	SW8260	DIBROMOMETHANE	0.00	µg/L	0.3000	U
WG	WG-SS10-DD01	AK102	DIESEL RANGE ORGANIC COMPOUNDS	6.70	mg/L	0.2000	J
WG	WG-SS10-DD01	SW8270	DIETHYL PHTHALATE	0.00	µg/L	4.0000	U
WG	WG-SS10-DD01	SW8270	DIMETHYL PHTHALATE	0.00	µg/L	4.0000	U
WG	WG-SS10-DD01	SW8260	ETHYLBENZENE	0.00	µg/L	0.3000	U
WG	WG-SS10-DD01	SW8270	FLUORANTHENE	0.00	µg/L	3.0000	U
WG	WG-SS10-DD01	SW8270	FLUORINE	4.00	µg/L	3.0000	J
WG	WG-SS10-DD01	AK101	GASOLINE RANGE ORGANIC COMPOUNDS	2600.00	µg/L	70.0000	
WG	WG-SS10-DD01	SW8270	HEXACHLOROBENZENE	0.00	µg/L	2.0000	U
WG	WG-SS10-DD01	SW8270	HEXACHLOROBUTADIENE	0.00	µg/L	4.0000	U
WG	WG-SS10-DD01	SW8270	HEXACHLOROCYCLOPENTADIENE	0.00	µg/L	3.0000	U
WG	WG-SS10-DD01	SW8270	HEXACHLOROETHANE	0.00	µg/L	4.0000	U
WG	WG-SS10-DD01	SW8270	INDENO (1,2,3-c,d) PYRENE	0.00	µg/L	4.0000	U
WG	WG-SS10-DD01	SW8270	ISOPHORONE	0.00	µg/L	5.0000	U
WG	WG-SS10-DD01	SW8260	METHYLENE CHLORIDE	0.00	µg/L	0.4000	U
WG	WG-SS10-DD01	SW8270	N-NITROSODI-n-PROPYLAMINE	0.00	µg/L	5.0000	U
WG	WG-SS10-DD01	SW8270	N-NITROSODIPHENYLAMINE	0.00	µg/L	3.0000	U
WG	WG-SS10-DD01	SW8270	NAPHTHALENE	0.00	µg/L	5.0000	U
WG	WG-SS10-DD01	SW8270	NITROBENZENE	0.00	µg/L	5.0000	U
WG	WG-SS10-DD01	SW8270	PENTACHLOROPHENOL	0.00	µg/L	3.0000	U
WG	WG-SS10-DD01	SW8270	PHENANTHRENE	0.00	µg/L	3.0000	U
WG	WG-SS10-DD01	SW8270	PHENOL	0.00	µg/L	3.0000	U
WG	WG-SS10-DD01	SW8270	PYRENE	0.00	µg/L	3.0000	U
WG	WG-SS10-DD01	SW8260	STYRENE	0.00	µg/L	0.5000	U
WG	WG-SS10-DD01	SW8260	TETRACHLOROETHYLENE (PCE)	0.00	µg/L	0.5000	U

TABLE 3.1-1
Laboratory Analytical Results Diversion Ditch
Indian Mountain Long Range Radar Station

Matrix	Sample Identification	Test Method	Analyte	Value	Units	Detection Limit	Lab Qualifier
WG	WG-SS10-DD01	SW8260	TOLUENE	0.00	µg/L	0.3000	U
WG	WG-SS10-DD01	SW8260	TOTAL XYLENES	0.00	µg/L	0.3000	U
WG	WG-SS10-DD01	SW8260	trans-1,2-DICHLOROETHENE	0.00	µg/L	0.3000	U
WG	WG-SS10-DD01	SW8260	TRICHLOROETHYLENE (TCE)	0.00	µg/L	0.5000	U
WG	WG-SS10-DD01	SW8260	TRICHLOROFLUOROMETHANE	0.00	µg/L	0.4000	U
WG	WG-SS10-DD01	SW8260	VINYL CHLORIDE	0.00	µg/L	0.1000	U

Notes:

MG/L = milligrams per liter
µg/L = micrograms per liter

J = Estimated

SS = Surface soil

U = Undetected (analyzed for but undetected)

WG = Groundwater

Composite samples were collected from the decontamination area sediment drums filled in 1994 (Drums 26 and 32). The samples were submitted to the laboratory for rapid turnaround analysis of VOC and metals concentrations. These data were required to decide whether the sediment could be placed in the containment cell. These samples were also analyzed according to the Toxicity Characteristic Leaching Procedure (TCLP) with a normal turnaround time for results. The VOC and metals results were nondetections or below human health and ecological risk levels for most analytes and are included in Table 3.2-1. The TCLP results are also included in this table and are denoted by a "WL" matrix code and "TCLP" following the test method. The IDW samples from Drums 26 and 32 were designated SO-IDW-DR26 and SO-IDW-DR32.

Petroleum hydrocarbon test kit samples and laboratory samples were collected to characterize the soils in the cell. The samples were collected five days after soils were put in the cell and covered. Soil was collected from throughout the cell and homogenized. Four composite soil samples were analyzed using the petroleum hydrocarbon immunoassay test kits (EPA Method 4030). All four samples contained petroleum fuels above the maximum detection level. Test kit sensitivities at the maximum detection level correspond to GRO at concentrations greater than 200 ppm and greater than 300 ppm DRO. Specifications for the test kits were included in the Work Plan and SAP Addendum (Air Force 1995a). Three composite samples were sent to the laboratory for GRO and DRO analysis. These samples were designated SO-CC01-CS01 through -CS03. Three additional samples were collected from areas of obvious fuel contamination and analyzed for a suite of nutrient indicators. These analytes include the following: total Kjeldahl nitrogen, total phosphorus, alkalinity, total iron, and percent moisture. The nutrient sample numbers are SO-CC01-CS04 through -CS06. All laboratory results are summarized in Table 3.2-1. Mean concentrations of analytes are summarized in Table 3.2-2.

TABLE 3.2-1
Laboratory Analytical Results Containment Cell and Investigation-Derived Waste Drums
Indian Mountain Long Range Radar Station

Matrix	Sample Identification	Test Method	Analyte	Value	Units	Detection Limit	Lab Qualifier	Human Health Risk	Ecological Risk
SS	SO-CC01-CS01	AK102	DIESEL RANGE ORGANIC COMPOUNDS	36.00	MG/KG	0.9000			
SS	SO-CC01-CS01	AK101	GASOLINE RANGE ORGANIC COMPOUNDS	0.31	MG/KG	0.0800	J		
SS	SO-CC01-CS02	AK102	DIESEL RANGE ORGANIC COMPOUNDS	50.00	MG/KG	0.9000			
SS	SO-CC01-CS02	AK101	GASOLINE RANGE ORGANIC COMPOUNDS	0.55	MG/KG	0.0800	J		
SS	SO-CC01-CS03	AK102	DIESEL RANGE ORGANIC COMPOUNDS	35.00	MG/KG	1.0000			
SS	SO-CC01-CS03	AK101	GASOLINE RANGE ORGANIC COMPOUNDS	1.70	MG/KG	0.0800			
SS	SO-CC01-CS04	E310.1	ALKALINITY, BICARBONATE (AS CaCO3)	1300.00	MG/L	40.0000			
SS	SO-CC01-CS04	E310.1	ALKALINITY, CARBONATE (AS CaCO3)	0.00	MG/L	40.0000	U		
SS	SO-CC01-CS04	E310.1	ALKALINITY, HYDROXIDE (AS CaCO3)	0.00	MG/L	40.0000	U		
SS	SO-CC01-CS04	E310.1	ALKALINITY, TOTAL (AS CaCO3)	1300.00	MG/L	40.0000			
SS	SO-CC01-CS04	SW7380	IRON	36000.00	MG/KG	6.0000			
SS	SO-CC01-CS04	E351.2	NITROGEN, KJELDAHL, TOTAL	630.00	MG/KG	20.0000			
SS	SO-CC01-CS04	D2216	PERCENT MOISTURE	16.00	%				
SS	SO-CC01-CS04	365.4	PHOSPHORUS (AS P)	360.00	MG/KG				
SS	SO-CC01-CS04	365.4	TOTAL PHOSPHORUS (AS PO4)	1090.00	MG/KG				
SS	SO-CC01-CS05	E310.1	ALKALINITY, BICARBONATE (AS CaCO3)	410.00	MG/L	40.0000			
SS	SO-CC01-CS05	E310.1	ALKALINITY, CARBONATE (AS CaCO3)	0.00	MG/L	40.0000	U		
SS	SO-CC01-CS05	E310.1	ALKALINITY, HYDROXIDE (AS CaCO3)	0.00	MG/L	40.0000	U		
SS	SO-CC01-CS05	E310.1	ALKALINITY, TOTAL (AS CaCO3)	410.00	MG/L	40.0000			
SS	SO-CC01-CS05	SW7380	IRON	38000.00	MG/KG	7.0000			
SS	SO-CC01-CS05	E351.2	NITROGEN, KJELDAHL, TOTAL	380.00	MG/KG	20.0000			
SS	SO-CC01-CS05	D2216	PERCENT MOISTURE	27.00	%				
SS	SO-CC01-CS05	365.4	PHOSPHORUS (AS P)	420.00	MG/KG				
SS	SO-CC01-CS05	365.4	TOTAL PHOSPHORUS (AS PO4)	1300.00	MG/KG				
SS	SO-CC01-CS06	E310.1	ALKALINITY, BICARBONATE (AS CaCO3)	260.00	MG/L	40.0000			
SS	SO-CC01-CS06	E310.1	ALKALINITY, CARBONATE (AS CaCO3)	0.00	MG/L	40.0000	U		
SS	SO-CC01-CS06	E310.1	ALKALINITY, HYDROXIDE (AS CaCO3)	0.00	MG/L	40.0000	U		
SS	SO-CC01-CS06	E310.1	ALKALINITY, TOTAL (AS CaCO3)	260.00	MG/L	40.0000			
SS	SO-CC01-CS06	SW7380	IRON	36000.00	MG/KG	6.0000			
SS	SO-CC01-CS06	E351.2	NITROGEN, KJELDAHL, TOTAL	290.00	MG/KG	20.0000			
SS	SO-CC01-CS06	D2216	PERCENT MOISTURE	17.00	%				
SS	SO-CC01-CS06	365.4	PHOSPHORUS (AS P)	360.00	MG/KG				
SS	SO-CC01-CS06	365.4	TOTAL PHOSPHORUS (AS PO4)	1100.00	MG/KG				
SS	SO-IDW-DR26	SW8240	1,1,1-TRICHLOROETHANE	0.00	MG/KG	0.0007	U		
SS	SO-IDW-DR26	SW8240	1,1,2,2-TETRACHLOROETHANE	0.00	MG/KG	0.0015	U		
SS	SO-IDW-DR26	SW8240	1,1,2-TRICHLOROETHANE	0.00	MG/KG	0.0016	U		
SS	SO-IDW-DR26	SW8240	1,1-DICHLOROETHANE	0.00	MG/KG	0.0003	U		
SS	SO-IDW-DR26	SW8240	1,1-DICHLOROETHENE	0.00	MG/KG	0.0007	U		

TABLE 3.2-1
Laboratory Analytical Results Containment Cell and Investigation-Derived Waste Drums
Indian Mountain Long Range Radar Station

Matrix	Sample Identification	Test Method	Analyte	Value	Units	Detection Limit	Lab Qualifier	Human Health Risk	Ecological Risk
SS	SO-IDW-DR26	SW8240	1,2-DICHLOROETHANE	0.00	MG/KG	0.0015	U		
SS	SO-IDW-DR26	SW8240	1,2-DICHLOROPROPANE	0.00	MG/KG	0.0006	U		
SS	SO-IDW-DR26	SW8240	2-CHLOROETHYL VINYL ETHER	0.00	MG/KG	0.0016	U		
SS	SO-IDW-DR26	SW8240	2-HEXANONE	0.00	MG/KG	0.0040	U		
SS	SO-IDW-DR26	SW8240	ACETONE	0.04	MG/KG	0.0150	J		
SS	SO-IDW-DR26	SW6010	ALUMINUM	21000.00	MG/KG	15.0000			
SS	SO-IDW-DR26	SW6010	ANTIMONY	0.00	MG/KG	8.0000	U		
SS	SO-IDW-DR26	SW6010	ARSENIC	7.40	MG/KG	4.0000	J	CI	
SS	SO-IDW-DR26	SW6010	BARIUM	190.00	MG/KG	0.1000			
SS	SO-IDW-DR26	SW8240	BENZENE	0.00	MG/KG	0.0007	J		
SS	SO-IDW-DR26	SW8240	BERYLLIUM	0.44	MG/KG	0.0300			
SS	SO-IDW-DR26	SW8240	BROMODICHLOROMETHANE	0.00	MG/KG	0.0003	U		
SS	SO-IDW-DR26	SW8240	BROMOFORM	0.00	MG/KG	0.0005	U		
SS	SO-IDW-DR26	SW8240	BROMOMETHANE	0.00	MG/KG	0.0016	U		
SS	SO-IDW-DR26	SW6010	CADMIUM	5.30	MG/KG	0.3000		AB CI	AB
SS	SO-IDW-DR26	SW6010	CALCIUM	7900.00	MG/KG	3.0000		AB	AB
SS	SO-IDW-DR26	SW8240	CARBON DISULFIDE	0.00	MG/KG	0.0030	U		
SS	SO-IDW-DR26	SW8240	CARBON TETRACHLORIDE	0.00	MG/KG	0.0015	U		
SS	SO-IDW-DR26	SW8240	CHLOROBENZENE	0.00	MG/KG	0.0005	U		
SS	SO-IDW-DR26	SW8240	CHLOROETHANE	0.00	MG/KG	0.0010	U		
SS	SO-IDW-DR26	SW8240	CHLOROFORM	0.00	MG/KG	0.0010	U		
SS	SO-IDW-DR26	SW8240	CHLOROMETHANE	0.00	MG/KG	0.0016	U		
SS	SO-IDW-DR26	SW6010	CHROMIUM, TOTAL	34.00	MG/KG	0.6000			
SS	SO-IDW-DR26	SW8240	cis-1,2-DICHLOROETHYLENE	0.00	MG/KG	0.0010	U		
SS	SO-IDW-DR26	SW8240	cis-1,3-DICHLOROPROPENE	0.00	MG/KG	0.0009	U		
SS	SO-IDW-DR26	SW6010	COBALT	18.00	MG/KG	0.6000			
SS	SO-IDW-DR26	SW6010	COPPER	53.00	MG/KG	0.6000			
SS	SO-IDW-DR26	SW8240	DIBROMOCHLOROMETHANE	0.00	MG/KG	0.0009	U		
SS	SO-IDW-DR26	SW8240	ETHYLBENZENE	0.07	MG/KG	0.0006			
SS	SO-IDW-DR26	SW6010	IRON	38000.00	MG/KG	0.6000			
SS	SO-IDW-DR26	SW6010	LEAD	44.00	MG/KG	4.0000	J	AB	AB
SS	SO-IDW-DR26	SW6010	MAGNESIUM	9900.00	MG/KG	5.0000			
SS	SO-IDW-DR26	SW6010	MANGANESE	580.00	MG/KG	0.1000			
SS	SO-IDW-DR26	SW8240	METHYL ETHYL KETONE (2-BUTANONE)	0.02	MG/KG	0.0050	J		
SS	SO-IDW-DR26	SW8240	METHYL ISOBUTYL KETONE (4-METHYL-2-PENTANONE)	0.00	MG/KG	0.0030	U		
SS	SO-IDW-DR26	SW8240	METHYLENE CHLORIDE	0.00	MG/KG	0.0009	U		
SS	SO-IDW-DR26	SW6010	MOLYBDENUM	0.00	MG/KG	0.4000	U		
SS	SO-IDW-DR26	SW6010	NICKEL	9.40	MG/KG	3.0000	J		

TABLE 3.2-1
Laboratory Analytical Results Containment Cell and Investigation-Derived Waste Drums
Indian Mountain Long Range Radar Station

Matrix	Sample Identification	Test Method	Analyte	Value	Units	Detection Limit	Lab Qualifier	Human Health Risk	Ecological Risk
SS	SO-IDW-DR26	SW6010	POTASSIUM	690.00	MG/KG	26.0000			
SS	SO-IDW-DR26	SW6010	SELENIUM	0.00	MG/KG	5.0000	U		
SS	SO-IDW-DR26	SW6010	SILVER	0.00	MG/KG	1.0000	U		
SS	SO-IDW-DR26	SW6010	SODIUM	360.00	MG/KG	6.0000			
SS	SO-IDW-DR26	SW8240	STYRENE	0.00	MG/KG	0.0016	U		
SS	SO-IDW-DR26	SW8240	TETRACHLOROETHYLENE (PCE)	0.00	MG/KG	0.0006	U		
SS	SO-IDW-DR26	SW6010	THALLIUM	5.20	MG/KG	3.0000	J		
SS	SO-IDW-DR26	SW8240	TOLUENE	0.23	MG/KG	0.0005			
SS	SO-IDW-DR26	SW8240	TOTAL XYLENES	0.64	MG/KG	0.0040			
SS	SO-IDW-DR26	SW8240	trans-1,2-DICHLOROETHENE	0.00	MG/KG	0.0005	U		
SS	SO-IDW-DR26	SW8240	trans-1,3-DICHLOROPROPENE	0.00	MG/KG	0.0005	U		
SS	SO-IDW-DR26	SW8240	TRICHLOROETHYLENE (TCE)	0.00	MG/KG	0.0006	U		
SS	SO-IDW-DR26	SW6010	VANADIUM	83.00	MG/KG	0.6000			
SS	SO-IDW-DR26	SW8240	VINYL ACETATE	0.00	MG/KG	0.0010	U		
SS	SO-IDW-DR26	SW8240	VINYL CHLORIDE	0.00	MG/KG	0.0010	U		
SS	SO-IDW-DR26	SW8240	ZINC	99.00	MG/KG	0.4000			
WL	SO-IDW-DR26-WL	SW6010 - TCLP	ARSENIC	0.00	MG/L	0.0600	U		
WL	SO-IDW-DR26-WL	SW6010 - TCLP	BARIUM	1.70	MG/L	0.0020			
WL	SO-IDW-DR26-WL	SW6010 - TCLP	CADMIUM	0.00	MG/L	0.0040	U		
WL	SO-IDW-DR26-WL	SW6010 - TCLP	CHROMIUM, TOTAL	0.00	MG/L	0.0100	U		
WL	SO-IDW-DR26-WL	SW6010 - TCLP	LEAD	0.00	MG/L	0.0600	U		
WL	SO-IDW-DR26-WL	SW6010 - TCLP	SELENIUM	0.00	MG/L	0.0800	U		
WL	SO-IDW-DR26-WL	SW6010 - TCLP	SILVER	0.00	MG/L	0.0200	U		
WL	SO-IDW-DR26-WL	SW8240 - TCLP	1,1-DICHLOROETHENE	0.00	MG/L	0.0006	U		
WL	SO-IDW-DR26-WL	SW8240 - TCLP	1,2-DICHLOROETHANE	0.00	MG/L	0.0008	U		
WL	SO-IDW-DR26-WL	SW8240 - TCLP	1,4-DICHLOROBENZENE	0.00	µG/L	4.0000	U		
WL	SO-IDW-DR26-WL	SW8270 - TCLP	2,4,5-TRICHLOROPHENOL	0.00	µG/L	4.0000	U		
WL	SO-IDW-DR26-WL	SW8270 - TCLP	2,4,6-TRICHLOROPHENOL	0.00	µG/L	4.0000	U		
WL	SO-IDW-DR26-WL	SW8150 - TCLP	2,4-D (DICHLOROPHENOXACETIC ACID)	0.00	µG/L	0.3000	U		
WL	SO-IDW-DR26-WL	SW8270 - TCLP	2,4-DINITROTOLUENE	0.00	µG/L	3.0000	U		
WL	SO-IDW-DR26-WL	SW8270 - TCLP	2-METHYLPHENOL (o-CRESOL)	0.00	µG/L	3.0000	U		
WL	SO-IDW-DR26-WL	SW8270 - TCLP	3-METHYLPHENOL	0.00	µG/L	3.0000	U		
WL	SO-IDW-DR26-WL	SW8270 - TCLP	4-METHYLPHENOL (p-CRESOL)	41.00	µG/L	3.0000			
WL	SO-IDW-DR26-WL	SW8240 - TCLP	BENZENE	0.00	MG/L	0.0006	U		
WL	SO-IDW-DR26-WL	SW8240 - TCLP	CARBON TETRACHLORIDE	0.00	MG/L	0.0008	U		
WL	SO-IDW-DR26-WL	SW8080 - TCLP	CHLORDANE	0.00	µG/L	0.0080	U		
WL	SO-IDW-DR26-WL	SW8240 - TCLP	CHLOROBENZENE	0.00	MG/L	0.0004	U		
WL	SO-IDW-DR26-WL	SW8240 - TCLP	CHLOROFORM	0.00	MG/L	0.0010	J		

TABLE 3.2-1
Laboratory Analytical Results Containment Cell and Investigation-Derived Waste Drums
Indian Mountain Long Range Radar Station

Matrix	Sample Identification	Test Method	Analyte	Value	Units	Detection Limit	Lab Qualifier	Human Health Risk	Ecological Risk
WL	SO-IDW-DR26-WL	SW8270 - TCLP	CRESOLS, TOTAL	41.00	µG/L	10.0000			
WL	SO-IDW-DR26-WL	SW8080 - TCLP	ENDRIN	0.00	µG/L	0.0200	U		
WL	SO-IDW-DR26-WL	SW8080 - TCLP	GAMMA BHC (LINDANE)	0.00	µG/L	0.0090	U		
WL	SO-IDW-DR26-WL	SW8080 - TCLP	HEPTACHLOR	0.00	µG/L	0.0070	U		
WL	SO-IDW-DR26-WL	SW8080 - TCLP	HEPTACHLOR EPOXIDE	0.00	µG/L	0.0200	U		
WL	SO-IDW-DR26-WL	SW8270 - TCLP	HEXACHLOROBENZENE	0.00	µG/L	2.0000	U		
WL	SO-IDW-DR26-WL	SW8270 - TCLP	HEXACHLOROBUTADIENE	0.00	µG/L	4.0000	U		
WL	SO-IDW-DR26-WL	SW8270 - TCLP	HEXACHLOROETHANE	0.00	µG/L	4.0000	U		
WL	SO-IDW-DR26-WL	SW7470 - TCLP	MERCURY	0.00	MG/L	0.0001	U		
WL	SO-IDW-DR26-WL	SW8080 - TCLP	METHOXYCHLOR	0.00	µG/L	0.0200	U		
WL	SO-IDW-DR26-WL	SW8240 - TCLP	METHYL ETHYL KETONE (2-BUTANONE)	0.00	MG/L	0.0040	U		
WL	SO-IDW-DR26-WL	SW8270 - TCLP	NITROBENZENE	0.00	µG/L	5.0000	U		
WL	SO-IDW-DR26-WL	SW8270 - TCLP	PENTACHLOROPHENOL	0.00	µG/L	3.0000	U		
WL	SO-IDW-DR26-WL	SW8270 - TCLP	PHENOL	0.00	µG/L	3.0000	U		
WL	SO-IDW-DR26-WL	SW8270 - TCLP	PYRIDINE	0.00	µG/L	10.0000	U		
WL	SO-IDW-DR26-WL	SW8150 - TCLP	SILVEX (2,4,5-TP)	0.00	µG/L	0.0500	U		
WL	SO-IDW-DR26-WL	SW8240 - TCLP	TETRACHLOROETHYLENE (PCE)	0.00	MG/L	0.0005	U		
WL	SO-IDW-DR26-WL	SW8080 - TCLP	TOXAPHENE	0.00	µG/L	0.5000	U		
WL	SO-IDW-DR26-WL	SW8240 - TCLP	TRICHLOROETHYLENE (TCE)	0.00	MG/L	0.0005	U		
WL	SO-IDW-DR26-WL	SW8240 - TCLP	VINYL CHLORIDE	0.00	MG/L	0.0010	U		
SS	SO-IDW-DR32	SW8240	1,1,1-TRICHLOROETHANE	0.00	MG/KG	0.0007	U		
SS	SO-IDW-DR32	SW8240	1,1,2,2-TETRACHLOROETHANE	0.00	MG/KG	0.0015	U		
SS	SO-IDW-DR32	SW8240	1,1,2-TRICHLOROETHANE	0.00	MG/KG	0.0016	U		
SS	SO-IDW-DR32	SW8240	1,1-DICHLOROETHANE	0.00	MG/KG	0.0003	U		
SS	SO-IDW-DR32	SW8240	1,1-DICHLOROETHANE	0.00	MG/KG	0.0007	U		
SS	SO-IDW-DR32	SW8240	1,2-DICHLOROETHANE	0.00	MG/KG	0.0015	U		
SS	SO-IDW-DR32	SW8240	1,2-DICHLOROPROPANE	0.00	MG/KG	0.0006	U		
SS	SO-IDW-DR32	SW8240	2-CHLOROETHYL VINYL ETHER	0.00	MG/KG	0.0016	U		
SS	SO-IDW-DR32	SW8240	2-HEXANONE	0.00	MG/KG	0.0040	U		
SS	SO-IDW-DR32	SW8240	ACETONE	0.00	MG/KG	0.0150	U		
SS	SO-IDW-DR32	SW6010	ALUMINUM	15000.00	MG/KG	15.0000			
SS	SO-IDW-DR32	SW6010	ANTIMONY	8.60	MG/KG	8.0000	J		
SS	SO-IDW-DR32	SW6010	ARSENIC	6.40	MG/KG	4.0000	J	CI	
SS	SO-IDW-DR32	SW6010	BARIUM	170.00	MG/KG	0.1000			
SS	SO-IDW-DR32	SW8240	BENZENE	0.00	MG/KG	0.0007	U		
SS	SO-IDW-DR32	SW6010	BERYLLIUM	0.27	MG/KG	0.0300	J		
SS	SO-IDW-DR32	SW8240	BROMODICHLOROMETHANE	0.00	MG/KG	0.0003	U		
SS	SO-IDW-DR32	SW8240	BROMOFORM	0.00	MG/KG	0.0005	U		

TABLE 3.2-1
Laboratory Analytical Results Containment Cell and Investigation-Derived Waste Drums
Indian Mountain Long Range Radar Station

Matrix	Sample Identification	Test Method	Analyte	Value	Units	Detection Limit	Lab Qualifier	Human Health Risk	Ecological Risk
SS	SO-IDW-DR32	SW8240	BROMOMETHANE	0.00	MG/KG	0.0016	U		
SS	SO-IDW-DR32	SW6010	CADMIUM	4.90	MG/KG	0.3000	J	AB CI	AB
SS	SO-IDW-DR32	SW6010	CALCIUM	5400.00	MG/KG	3.0000			
SS	SO-IDW-DR32	SW8240	CARBON DISULFIDE	0.00	MG/KG	0.0030	U		
SS	SO-IDW-DR32	SW8240	CARBON TETRACHLORIDE	0.00	MG/KG	0.0015	U		
SS	SO-IDW-DR32	SW8240	CHLOROBENZENE	0.00	MG/KG	0.0005	U		
SS	SO-IDW-DR32	SW8240	CHLOROETHANE	0.00	MG/KG	0.0010	U		
SS	SO-IDW-DR32	SW8240	CHLOROFORM	0.00	MG/KG	0.0010	U		
SS	SO-IDW-DR32	SW8240	CHLOROMETHANE	0.00	MG/KG	0.0016	U		
SS	SO-IDW-DR32	SW8240	CHROMIUM, TOTAL	29.00	MG/KG	0.6000			
SS	SO-IDW-DR32	SW6010	CHROMIUM, TOTAL	0.00	MG/KG	0.0010	U		
SS	SO-IDW-DR32	SW8240	cis-1,2-DICHLOROETHYLENE	0.00	MG/KG	0.0008	U		
SS	SO-IDW-DR32	SW8240	cis-1,3-DICHLOROPROPENE	0.00	MG/KG	0.0008	U		
SS	SO-IDW-DR32	SW6010	COBALT	14.00	MG/KG	0.6000			
SS	SO-IDW-DR32	SW6010	COPPER	36.00	MG/KG	0.6000			
SS	SO-IDW-DR32	SW8240	DIBROMOCHLOROMETHANE	0.00	MG/KG	0.0008	U		
SS	SO-IDW-DR32	SW8240	ETHYLBENZENE	0.03	MG/KG	0.0006			
SS	SO-IDW-DR32	SW6010	IRON	28000.00	MG/KG	0.6000			
SS	SO-IDW-DR32	SW6010	LEAD	36.00	MG/KG	4.0000	J	AB	AB
SS	SO-IDW-DR32	SW6010	MAGNESIUM	8100.00	MG/KG	5.0000			
SS	SO-IDW-DR32	SW6010	MANGANESE	460.00	MG/KG	0.1000			
SS	SO-IDW-DR32	SW8240	METHYL ETHYL KETONE (2-BUTANONE)	0.00	MG/KG	0.0050	U		
SS	SO-IDW-DR32	SW8240	METHYL ISOBUTYL KETONE (4-METHYL-2-PENTANONE)	0.00	MG/KG	0.0030	U		
SS	SO-IDW-DR32	SW8240	METHYLENE CHLORIDE	0.00	MG/KG	0.0008	U		
SS	SO-IDW-DR32	SW6010	MOLYBDENUM	0.00	MG/KG	0.4000	U		
SS	SO-IDW-DR32	SW6010	NICKEL	10.00	MG/KG	3.0000	J		
SS	SO-IDW-DR32	SW6010	POTASSIUM	630.00	MG/KG	26.0000	J		
SS	SO-IDW-DR32	SW6010	SELENIUM	0.00	MG/KG	5.0000	U		
SS	SO-IDW-DR32	SW6010	SILVER	0.00	MG/KG	1.0000	U		
SS	SO-IDW-DR32	SW6010	SODIUM	120.00	MG/KG	6.0000			
SS	SO-IDW-DR32	SW8240	STYRENE	0.00	MG/KG	0.0016	U		
SS	SO-IDW-DR32	SW8240	TETRACHLOROETHYLENE (PCE)	0.00	MG/KG	0.0006	U		
SS	SO-IDW-DR32	SW6010	THALLIUM	0.00	MG/KG	3.0000	U		
SS	SO-IDW-DR32	SW8240	TOLUENE	0.19	MG/KG	0.0005			
SS	SO-IDW-DR32	SW8240	TOTAL XYLENES	0.19	MG/KG	0.0040			
SS	SO-IDW-DR32	SW8240	trans-1,2-DICHLOROETHENE	0.00	MG/KG	0.0005	U		
SS	SO-IDW-DR32	SW8240	trans-1,3-DICHLOROPROPENE	0.00	MG/KG	0.0005	U		
SS	SO-IDW-DR32	SW8240	TRICHLOROETHYLENE (TCE)	0.00	MG/KG	0.0006	U		
SS	SO-IDW-DR32	SW6010	VANADIUM	55.00	MG/KG	0.6000			

TABLE 3.2-1
Laboratory Analytical Results Containment Cell and Investigation-Derived Waste Drums
Indian Mountain Long Range Radar Station

Matrix	Sample Identification	Test Method	Analyte	Value	Units	Detection Limit	Lab Qualifier	Human Health Risk	Ecological Risk
SS	SO-IDW-DR32	SW8240	VINYL ACETATE	0.00	MG/KG	0.0010	U		
SS	SO-IDW-DR32	SW8240	VINYL CHLORIDE	0.00	MG/KG	0.0010	U		
SS	SO-IDW-DR32	SW6010	ZINC	95.00	MG/KG	0.4000			
WL	SO-IDW-DR32-WL	SW6010 - TCLP	ARSENIC	0.00	MG/L	0.0600	U		
WL	SO-IDW-DR32-WL	SW6010 - TCLP	BARIUM	1.90	MG/L	0.0020			
WL	SO-IDW-DR32-WL	SW6010 - TCLP	CADMIUM	0.02	MG/L	0.0040	J		
WL	SO-IDW-DR32-WL	SW6010 - TCLP	CHROMIUM, TOTAL	0.00	MG/L	0.0100	U		
WL	SO-IDW-DR32-WL	SW6010 - TCLP	LEAD	0.18	MG/L	0.0600	J		
WL	SO-IDW-DR32-WL	SW6010 - TCLP	SELENIUM	0.00	MG/L	0.0800	U		
WL	SO-IDW-DR32-WL	SW6010 - TCLP	SILVER	0.00	MG/L	0.0200	U		
WL	SO-IDW-DR32-WL	SW8240 - TCLP	1,1-DICHLOROETHENE	0.00	MG/L	0.0006	U		
WL	SO-IDW-DR32-WL	SW8240 - TCLP	1,2-DICHLOROETHANE	0.00	MG/L	0.0008	U		
WL	SO-IDW-DR32-WL	SW8270 - TCLP	1,4-DICHLOROBENZENE	0.00	MG/L	4.0000	U		
WL	SO-IDW-DR32-WL	SW8270 - TCLP	2,4,5-TRICHLOROPHENOL	0.00	MG/L	4.0000	U		
WL	SO-IDW-DR32-WL	SW8270 - TCLP	2,4,6-TRICHLOROPHENOL	0.00	MG/L	4.0000	U		
WL	SO-IDW-DR32-WL	SW8150 - TCLP	2,4-D (DICHLOROPHENOXYACETIC ACID)	0.00	MG/L	0.3000	U		
WL	SO-IDW-DR32-WL	SW8270 - TCLP	2,4-DINITROTOLUENE	0.00	MG/L	3.0000	U		
WL	SO-IDW-DR32-WL	SW8270 - TCLP	2-METHYLPHENOL (o-CRESOL)	0.00	MG/L	3.0000	U		
WL	SO-IDW-DR32-WL	SW8270 - TCLP	3-METHYLPHENOL	0.00	MG/L	3.0000	U		
WL	SO-IDW-DR32-WL	SW8270 - TCLP	4-METHYLPHENOL (p-CRESOL)	0.00	MG/L	3.0000	U		
WL	SO-IDW-DR32-WL	SW8240 - TCLP	BENZENE	0.00	MG/L	0.0006	U		
WL	SO-IDW-DR32-WL	SW8240 - TCLP	CARBON TETRACHLORIDE	0.00	MG/L	0.0008	U		
WL	SO-IDW-DR32-WL	SW8080 - TCLP	CHLORDANE	0.00	MG/L	0.0080	U		
WL	SO-IDW-DR32-WL	SW8240 - TCLP	CHLOROBENZENE	0.00	MG/L	0.0004	U		
WL	SO-IDW-DR32-WL	SW8240 - TCLP	CHLOROFORM	0.00	MG/L	0.0010	J		
WL	SO-IDW-DR32-WL	SW8270 - TCLP	CRESOLS, TOTAL	0.00	MG/L	10.0000	U		
WL	SO-IDW-DR32-WL	SW8270 - TCLP	ENDRIN	0.00	MG/L	0.0200	U		
WL	SO-IDW-DR32-WL	SW8080 - TCLP	GAMMA BHC (LINDANE)	0.00	MG/L	0.0090	U		
WL	SO-IDW-DR32-WL	SW8080 - TCLP	HEPTACHLOR	0.00	MG/L	0.0070	U		
WL	SO-IDW-DR32-WL	SW8080 - TCLP	HEPTACHLOR EPOXIDE	0.00	MG/L	0.0200	U		
WL	SO-IDW-DR32-WL	SW8270 - TCLP	HEXACHLOROBENZENE	0.00	MG/L	2.0000	U		
WL	SO-IDW-DR32-WL	SW8270 - TCLP	HEXACHLOROBUTADIENE	0.00	MG/L	4.0000	U		
WL	SO-IDW-DR32-WL	SW8270 - TCLP	HEXACHLOROETHANE	0.00	MG/L	4.0000	U		
WL	SO-IDW-DR32-WL	SW7470 - TCLP	MERCURY	0.00	MG/L	0.0001	U		
WL	SO-IDW-DR32-WL	SW8080 - TCLP	METHOXYCHLOR	0.00	MG/L	0.0200	U		
WL	SO-IDW-DR32-WL	SW8240 - TCLP	METHYL ETHYL KETONE (2-BUTANONE)	0.00	MG/L	0.0040	U		
WL	SO-IDW-DR32-WL	SW8270 - TCLP	NITROBENZENE	0.00	MG/L	5.0000	U		
WL	SO-IDW-DR32-WL	SW8270 - TCLP	PENTACHLOROPHENOL	0.00	MG/L	3.0000	U		

TABLE 3.2-1
Laboratory Analytical Results Containment Cell and Investigation-Derived Waste Drums
Indian Mountain Long Range Radar Station

Matrix	Sample Identification	Test Method	Analyte	Value	Units	Detection Limit	Lab Qualifier	Human Health Risk	Ecological Risk
WL	SO-IDW-DR32-WL	SW8270 - TCLP	PHENOL	0.00	µG/L	3.0000	U		
WL	SO-IDW-DR32-WL	SW8270 - TCLP	PYRIDINE	0.00	µG/L	10.0000	U		
WL	SO-IDW-DR32-WL	SW8150 - TCLP	SILVEX (2,4,5-TP)	0.00	µG/L	0.0200	U		
WL	SO-IDW-DR32-WL	SW8240 - TCLP	TETRACHLOROETHYLENE (PCE)	0.00	MG/L	0.0005	U		
WL	SO-IDW-DR32-WL	SW8080 - TCLP	TOXAPHENE	0.00	µG/L	0.5000	U		
WL	SO-IDW-DR32-WL	SW8240 - TCLP	TRICHLOROETHYLENE (TCE)	0.00	MG/L	0.0005	U		
WL	SO-IDW-DR32-WL	SW8240 - TCLP	VINYL CHLORIDE	0.00	MG/L	0.0010	U		

NOTES:

MG/KG = milligrams per kilogram
 MG/L = milligrams per liter
 µG/L = micrograms per liter
 % = percent

AB = Exceeds the maximum background value for the medium

CC01 = Containment cell

CI = Industrial carcinogenic 10⁻⁶ soil only - human health PRG (Preliminary Remediation Goal)

IDW = Investigation-derived waste drum

J = Estimated

SS = Surface soil

U = Undetected (analyzed for but undetected)

WL = Leachate

All samples are composite samples

TABLE 3.2-2
Mean Analyte Concentrations
Containment Cell and IDW Drums
Indian Mountain Long Range Radar Station

CONTAINMENT CELL	Value	Units
DIESEL RANGE ORGANIC COMPOUNDS	40.00	MG/KG
GASOLINE RANGE ORGANIC COMPOUNDS	0.85	MG/KG
ALKALINITY, BICARBONATE (AS CaCO ₃)	657.00	MG/L
ALKALINITY, TOTAL (AS CaCO ₃)	657.00	MG/L
IRON	36667.00	MG/KG
NITROGEN, KJELDAHL, TOTAL	433.00	MG/KG
PERCENT MOISTURE	20.00	%
PHOSPHORUS (AS P)	380.00	MG/KG
TOTAL PHOSPHORUS (AS PO ₄)	1163.00	MG/KG
INVESTIGATION-DERIVED WASTE DRUMS		
ACETONE *	0.04	MG/KG
ALUMINUM	18000.00	MG/KG
ARSENIC	6.90	MG/KG
BARIUM	180.00	MG/KG
BERYLLIUM	0.35	MG/KG
CADMIUM	5.10	MG/KG
CALCIUM	6650.00	MG/KG
CHROMIUM, TOTAL	31.50	MG/KG
COBALT	16.00	MG/KG
COPPER	45.00	MG/KG
ETHYLBENZENE	0.05	MG/KG
IRON	33000.00	MG/KG
LEAD	40.00	MG/KG
MAGNESIUM	9000.00	MG/KG
MANGANESE	520.00	MG/KG
METHYL ETHYL KETONE (2-BUTANONE) *	0.02	MG/KG
NICKEL	9.70	MG/KG
POTASSIUM	660.00	MG/KG
SODIUM	240.00	MG/KG
THALLIUM *	5.20	MG/KG
TOLUENE	0.42	MG/KG
TOTAL XYLENES	0.42	MG/KG
VANADIUM	69.00	MG/KG
ZINC	97.00	MG/KG
INVESTIGATION-DERIVED WASTE LEACHATE		
4-METHYLPHENOL (p-CRESOL) *	41.00	µG/L
BARIUM	1.80	MG/L
CADMIUM *	0.02	MG/L
LEAD *	0.18	MG/L
CRESOLS, TOTAL *	41.00	µG/L

NOTES:

MG/KG = milligrams per kilogram

MG/L = milligrams per liter

µG/L = micrograms per liter

% = percent

* = detected in one sample

The following discussion describes contaminants detected in 1995 IDW drum and containment cell samples. An evaluation of potential human health or ecological risk of negative effects associated with detected contaminants is provided when appropriate.

Metals. The concentrations of the metals cadmium and lead detected in Drums 26 and 32 were slightly above the background 99 percent upper tolerance limit (UTL) calculated with 95 percent confidence for surface soil using 1994 analytical results. These samples were designated SO-IDW-DR26 and -DR32. The background levels are shown in Table 3.2-3. The cadmium detections were below the background 99 percent UTL with 95 percent confidence for both sediment and subsurface soil. The lead levels were below the UTL for sediment and slightly greater than the subsurface soil UTL. The 1995 detections were about 10 percent greater than the surface soil UTLs and significantly below the sediment UTLs. Arsenic concentrations in both IDW samples exceeded the human health risk-based screening level, but were below background levels measured at the site in 1994. The metals concentrations are not considered a human health or ecological concern because the levels are generally within the range of background concentrations measured at Indian Mountain. Background levels for all media, and an explanation of their derivations, were included in Section 3.1 of the final RI/FS Report (Air Force 1995c). The 1994 background levels for sediment, surface soil, and subsurface soil are included in Table 3.2-3.

GRO and DRO. Three composited containment cell samples, designated SO-CC01-CS01 through -CS03, were analyzed for GRO and DRO content. Detections were well below the most stringent Alaska non-underground storage tank (UST) levels (Alaska Department of Environmental Conservation [ADEC] 1991). The cleanup level used for diesel range petroleum hydrocarbon compounds is 100 mg/kg. The level used for gasoline range petroleum compounds is 40 mg/kg. The test kit analyses indicated that greater than 200 ppm GRO (or 300 ppm DRO) was present in the soils.

TABLE 3.2-3
1994 Background Metals Levels
 UTL Estimates for Sediment
 (mg/kg)

ANALYTE	MEAN	STD	CV	N	K(95,95)	UTL(95,95)	K(95,99)	UTL(95,99)
Aluminum	2.604E+04	1.030E+04	3.956E-01	8	3.188	5.888E+04	4.355	7.090E+04
Antimony	4.856E+00	1.987E+00	4.092E-01	8	3.188	1.119E+01	4.355	1.351E+01
Arsenic	6.300E+00	2.500E+00	3.968E-01	8	3.188	1.427E+01	4.355	1.719E+01
Barium	6.330E+02	6.481E+02	1.024E+00	8	3.188	2.699E+03	4.355	3.456E+03
Beryllium	5.963E-01	3.514E-01	5.894E-01	8	3.188	1.717E+00	4.355	2.127E+00
Cadmium	3.499E+00	2.622E+00	7.495E-01	8	3.188	1.186E+01	4.355	1.492E+01
Calcium	8.264E+03	7.331E+03	8.871E-01	8	3.188	3.163E+04	4.355	4.019E+04
Chromium	1.881E+01	8.904E+00	4.733E-01	8	3.188	4.720E+01	4.355	5.759E+01
Cobalt	1.599E+01	5.233E+00	3.273E-01	8	3.188	3.267E+01	4.355	3.878E+01
Copper	4.229E+01	2.230E+01	5.274E-01	8	3.188	1.134E+02	4.355	1.394E+02
Iron	3.666E+04	1.276E+04	3.480E-01	8	3.188	7.734E+04	4.355	9.223E+04
Lead	5.114E+01	9.354E+01	1.829E+00	8	3.188	3.493E+02	4.355	4.585E+02
Magnesium	8.051E+03	1.049E+03	1.303E-01	8	3.188	1.140E+04	4.355	1.262E+04
Manganese	8.051E+02	4.366E+02	5.422E-01	8	3.188	2.197E+03	4.355	2.706E+03
Nickel	1.471E+01	5.830E+00	3.963E-01	8	3.188	3.330E+01	4.355	4.010E+01
Potassium	1.305E+03	8.307E+02	6.365E-01	8	3.188	3.953E+03	4.355	4.923E+03
Selenium	2.039E+01	2.324E+01	1.140E+00	8	3.188	9.447E+01	4.355	1.216E+02
Sodium	3.746E+02	3.087E+02	8.241E-01	8	3.188	1.359E+03	4.355	1.719E+03
Thallium	1.190E+01	1.067E+01	8.962E-01	8	3.188	4.591E+01	4.355	5.835E+01
Vanadium	6.986E+01	2.128E+01	3.046E-01	8	3.188	1.377E+02	4.355	1.625E+02
Zinc	2.079E+02	2.770E+02	1.333E+00	8	3.188	1.091E+03	4.355	1.414E+03

TABLE 3.2-3
1994 Background Metals Levels
 UTL Estimates for Surface Soil
 (mg/kg)

ANALYTE	MEAN	STD	CV	N	K(.95,.95)	UTL(.95,.95)	K(.95,.99)	UTL(.95,.99)
Aluminum	1.339E+04	7.313E+03	5.460E-01	5	4.21	4.418E+04	5.749	5.544E+04
Antimony	4.580E+00	1.997E+00	4.360E-01	5	4.21	1.299E+01	5.749	1.606E+01
Barium	1.594E+02	6.609E+01	4.146E-01	5	4.21	4.377E+02	5.749	5.394E+02
Beryllium	3.010E-01	8.127E-02	2.700E-01	5	4.21	6.432E-01	5.749	7.682E-01
Cadmium	1.360E+00	5.067E-01	3.726E-01	5	4.21	3.493E+00	5.749	4.273E+00
Calcium	2.846E+03	6.885E+02	2.419E-01	5	4.21	5.745E+03	5.749	6.804E+03
Chromium	1.196E+01	7.177E+00	6.001E-01	5	4.21	4.217E+01	5.749	5.322E+01
Cobalt	1.087E+01	6.378E+00	5.868E-01	5	4.21	3.772E+01	5.749	4.754E+01
Copper	1.864E+01	1.240E+01	6.652E-01	5	4.21	7.084E+01	5.749	8.992E+01
Iron	2.348E+04	1.381E+04	5.884E-01	5	4.21	8.164E+04	5.749	1.029E+05
Lead	8.820E+00	4.926E+00	5.585E-01	5	4.21	2.956E+01	5.749	3.714E+01
Magnesium	5.500E+03	3.058E+03	5.560E-01	5	4.21	1.838E+04	5.749	2.308E+04
Manganese	7.112E+02	8.985E+02	1.263E+00	5	4.21	4.494E+03	5.749	5.877E+03
Nickel	1.018E+01	5.451E+00	5.355E-01	5	4.21	3.313E+01	5.749	4.152E+01
Potassium	1.064E+03	6.999E+02	6.578E-01	5	4.21	4.011E+03	5.749	5.088E+03
Sodium	1.084E+02	6.532E+01	6.026E-01	5	4.21	3.834E+02	5.749	4.840E+02
Vanadium	4.222E+01	2.373E+01	5.621E-01	5	4.21	1.421E+02	5.749	1.787E+02
Zinc	4.518E+01	1.288E+01	2.850E-01	5	4.21	9.939E+01	5.749	1.192E+02

TABLE 3.2-3
1994 Background Metals Levels
 UTL Estimates for Subsurface Soil
 (mg/kg)

ANALYTE	MEAN	STD	CV	N	K(95,95)	UTL(95,95)	K(95,99)	UTL(95,99)
Aluminum	1.451E+04	5.772E+03	3.979E-01	5	4.21	3.881E+04	5.749	4.769E+04
Antimony	3.620E+00	2.449E+00	6.765E-01	5	4.21	1.393E+01	5.749	1.770E+01
Barium	2.163E+02	1.409E+02	6.513E-01	5	4.21	8.093E+02	5.749	1.026E+03
Beryllium	3.040E-01	1.670E-01	5.493E-01	5	4.21	1.007E+00	5.749	1.264E+00
Cadmium	1.512E+00	9.357E-01	6.188E-01	5	4.21	5.451E+00	5.749	6.891E+00
Calcium	3.440E+03	2.405E+03	6.991E-01	5	4.21	1.356E+04	5.749	1.727E+04
Chromium	1.270E+01	4.177E+00	3.289E-01	5	4.21	3.029E+01	5.749	3.672E+01
Cobalt	1.060E+01	4.777E+00	4.507E-01	5	4.21	3.071E+01	5.749	3.806E+01
Copper	2.210E+01	1.313E+01	5.940E-01	5	4.21	7.736E+01	5.749	9.756E+01
Iron	2.360E+04	1.128E+04	4.781E-01	5	4.21	7.110E+04	5.749	8.846E+04
Lead	8.880E+00	2.666E+00	3.002E-01	5	4.21	2.010E+01	5.749	2.421E+01
Magnesium	5.452E+03	3.409E+03	6.253E-01	5	4.21	1.980E+04	5.749	2.505E+04
Manganese	3.374E+02	2.495E+02	7.394E-01	5	4.21	1.388E+03	5.749	1.772E+03
Nickel	9.820E+00	2.845E+00	2.897E-01	5	4.21	2.180E+01	5.749	2.617E+01
Potassium	9.926E+02	7.670E+02	7.727E-01	5	4.21	4.222E+03	5.749	5.402E+03
Selenium	1.236E+01	2.220E+01	1.796E+00	5	4.21	1.058E+02	5.749	1.400E+02
Sodium	1.312E+02	1.900E+02	1.448E+00	5	4.21	9.312E+02	5.749	1.224E+03
Thallium	7.557E+00	1.043E+01	1.380E+00	5	4.21	5.145E+01	5.749	6.749E+01
Vanadium	4.652E+01	2.156E+01	4.634E-01	5	4.21	1.373E+02	5.749	1.704E+02
Zinc	4.784E+01	2.164E+01	4.524E-01	5	4.21	1.390E+02	5.749	1.723E+02

NOTES:

- CV = coefficient of variation = STD/MEAN
- K = Tabulated Factor (Gilbert 1987)
- mg/kg = milligrams per kilogram
- MEAN = sample mean
- N = sample size
- p = quantile
- STD = sample standard deviation
- UTL = upper tolerance level
- UTL(1 - α , p) = MEAN + K(1 - α , p)*STD
- 1 - α = confidence level

The laboratory results and test kit results do not correlate. This lack of agreement may be linked to the presence of naphthalene in the soils. Naphthalene can interfere with the test kit analyses by causing false-positive results, even at low concentrations. A review of the 1994 analytical results for the soils added to the cell suggests that naphthalene was detected in a majority of the laboratory samples. SVOC analyses, which include naphthalene, were not performed on the samples collected in 1995. Therefore, it is likely that the combination of petroleum hydrocarbons and associated constituents in the soils resulted in a higher detected concentration in the test kit samples than was measured in the laboratory samples.

Physical Characteristics and Nutrients. Soil characteristics, including nutrients, were measured in laboratory samples designated SO-CC01-CS04 through -CS06. The mean moisture content measured in the nutrient samples was 20 percent. According to Wise and Trantolo (1994), the optimal range of water content (20 to 40 percent by weight) for a given site will depend on soil type, permeability, and contaminant saturation. According to EPA research (EPA 1993), 40 to 80 percent moisture is desirable, and the rate of degradation is moisture limited below 40 percent. Because of seasonal temperature and precipitation changes, the amount of water in the soils will probably fluctuate after the cell has been sitting undisturbed. It may be useful to measure soil moisture content in 1996 to evaluate whether sufficient water for metabolic activity exists in the soils. Nutrients measured included the following: phosphorus, alkalinity, iron, and nitrogen. None of the levels were abnormal, although these measurements will be more meaningful if compared to a future data set. Bioremediation sources recommend nitrogen to phosphorus ratios ranging from 10:1 to 5:1. The ratio of the mean concentrations of total nitrogen and total phosphorus is 1:2.6. This ratio suggests that nutrient deficiency may limit the rate of destruction.

Temperature, carbon dioxide (CO₂), and oxygen (O₂) measurements were made in containment cell soils six days after the soils were placed in the cell and covered. The

CO₂ concentration was 0.07 percent and the O₂ was 21 percent. These levels are normal, although a decrease in O₂ and an increase in CO₂ concentrations should occur during periods of biodegradation. The concentration of CO₂ in soil gas depends on the presence of O₂, and vice versa. Microbial and plant activity use O₂ and generate CO₂. In addition, moisture content and soil aeration can control gas flow through soils. From 2 to 4 percent O₂ is required to maintain aerobic conditions. The soil temperature was 57.8 degrees (°) Fahrenheit (F) when the ambient temperature was approximately 54° F. These measurements made during and after cell construction will serve as baseline data. Some or all of the parameters may be measured in the future to monitor biological activity. Future data can also be used to evaluate the need for moisture or nutrient supplementation.

4.0 CONCLUSIONS

The ditch and sampling port will be inspected periodically to ensure that the ditch is effective. Water samples will be collected from the sampling port annually for up to five years to evaluate contaminant levels migrating from source area SS10. Such sampling would be incorporated into the primary FS alternative for SS10, natural attenuation and long term monitoring. Although water was seeping into the ditch, it was not possible to determine whether 100 percent diversion was achieved. Future monitoring of the area, including visual observation of downgradient seeps, will be required to determine whether the diversion was successful. These data will be useful for remedial alternative evaluation because fuel concentrations in water will indicate whether solution of contaminants by water is a significant transport mechanism.

Containment cell soil samples did not contain organic contaminants above risk-based screening criteria. DRO and GRO were not detected above the minimum Alaska levels for USTs. The petroleum hydrocarbon test kit results did not correlate with the laboratory samples. As mentioned earlier, the presence of other fuel-related

compounds may have interfered with the test kit analyses. The Work Plan and SAP Addendum (Air Force 1995a) recommended that periodic test kit analysis of the cell soils be performed to monitor petroleum hydrocarbon degradation. Based on the results presented in this report, test kit monitoring is no longer recommended. Therefore, 1996 sampling plans for the containment cell will include composite sample collection for DRO, GRO, SVOC, and VOC laboratory analyses. DRO and GRO results are recommended for continuity, and SVOC and VOC data are necessary to determine contaminant presence and levels in the containment cell soils. Samples may also be analyzed for a suite of nutrient and physical parameters to compare to the baseline cell data collected in 1995. Temperature, CO₂, and O₂ should also be monitored at this time. The laboratory results will be evaluated to determine if continued operation of the cell is necessary, and if so, if specific nutrients should be added to enhance biodegradation. If the data indicate that treatment is complete, disposal options for the soils will be considered and implemented.

5.0 REFERENCES

- Alaska Department of Environmental Conservation (ADEC). 1991 (July). *Interim Guidance for Non-UST Contaminated Soil Cleanup Levels, Guidance No. 001, Rev. 1.*
- Gilbert, Richard O. 1987. *Statistical Methods for Environmental Pollution Monitoring.* Van Nostrand Reinhold, New York, 320 pp.
- Jacobs Engineering Group Inc. 1995 (January). *Investigation Derived Waste - Evaluation and Recommendations.* Indian Mountain Long Range Radar Station. Prepared for the U.S. Air Force.
- U.S. Air Force. 1995a (July). *Work Plan and Sampling and Analysis Plan for Interim Remedial Actions, Indian Mountain LRRS, Alaska.* Prepared for the 11th Air Control Wing, 611 Civil Engineer Squadron, Elmendorf, Alaska by Jacobs Engineering Group Inc.
- U.S. Air Force. 1995b (October). *Draft Remedial Investigation/Feasibility Study Addendum. Indian Mountain LRRS, Alaska.* Prepared for the 11th Air Control Wing, 611 Civil Engineer Squadron, Elmendorf, Alaska by Jacobs Engineering Group Inc.
- U.S. Air Force. 1995c (October). *Final Remedial Investigation/Feasibility Study. Indian Mountain LRRS, Alaska.* Prepared for the 11th Air Control Wing, 611 Civil Engineer Squadron, Elmendorf, Alaska by Jacobs Engineering Group Inc.
- U.S. Environmental Protection Agency. 1993 (August). *Guide for Conducting Treatability Studies Under CERCLA. Biodegradation Remedy Selection. Interim Guidance.* EPA/540/R-93/519a.
- Wise, D.L. and D.J. Trantolo. 1994. *Remediation of Hazardous Waste Contaminated Soils.* New York: Marcel Dekker, Inc.

(intentionally blank)

APPENDIX A

OT08 TEST PIT FIELD SAMPLING FORMS

SURFACE AND SUBSURFACE SOIL SAMPLING FIELD DATA FORM

PROJECT NAME: INDIAN MOUNTAIN LRRS

PROJECT NUMBER: 05G46200

LOC ID OT08-SS09

SITE ID: OT08

SAMPLE ID: SO-OT08-SB03

LOT CONTROL NO. IN-A100101

DATE: 8/11/95

TIME: 1045

WEATHER: Overcast, 50°F

FIELD SAMPLING TEAM: S. Brown, B. Davidson

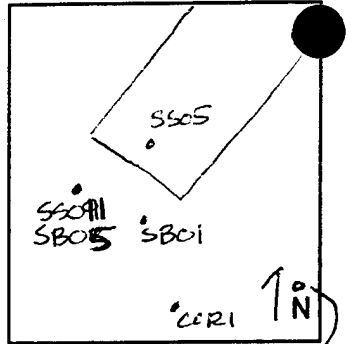

SAMPLING LOCATION: lab sample collected from 4.5-5' depth.

Approx 130' SE of COR1 marker on south side of OT08. Near area of former diesel tanks

SS09
SB03

COMPOSITE: YES NO COMPOSITE DESCRIPTION: A collection of soil from each depth

DEPTH OF SAMPLING INTERVAL: 0.5-1', 2.5-3' and 4.5-5' VOLUME COLLECTED: 1 4oz and

HEADSPACE READINGS: _____ 3 20g test kit samples
- all for PCB analysis

DESCRIPTION OF SOIL MATERIALS:

Gray, silty/clayey, moist soils with 40-50% gravel and boulders. Sheen on soils and strong degraded fuel odor. Water trickled in about 1' bgs. Bedrock not encountered

FIELD TEST KIT SCREENING TPH: _____ PCB: Aroclor 1260

SAMPLE IDs:	RESULTS:
SS09-01	>1, <10 ppm
SS09-02	-NA ND 8/12/95
SS09-03	NA
	NA= not analyzed
	ND= not detected

DATE AND TIME OF TEST KIT SCREENING 8/11/95 1530

COMPLETED BY:

Sarah Brown

Sarah Brown

8/11/95

PRINT NAME

SIGNATURE

DATE

CHECKED BY:

PRINT NAME

SIGNATURE

DATE

SURFACE AND SUBSURFACE SOIL SAMPLING FIELD DATA FORM

PROJECT NAME: INDIAN MOUNTAIN LRRS
 PROJECT NUMBER: 05G46200
 SITE ID: OTOS
 SAMPLE ID: Variety/no lab LOT CONTROL NO. _____
 DATE: 8/9/95 TIME: 1145-1315
 WEATHER: cloudy, breezy, 50°F
 FIELD SAMPLING TEAM: S. Brown & R. Henry

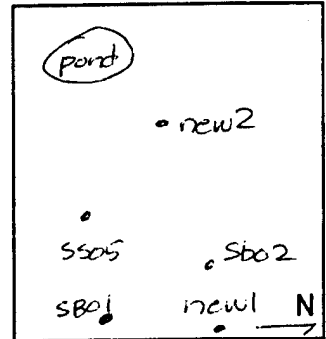

SAMPLING LOCATION:
1st two were along the road between the last switchback and Top Camp. 3rd & 4th were on north side of lower bench

COMPOSITE: YES/NO COMPOSITE DESCRIPTION: _____

DEPTH OF SAMPLING INTERVAL: 0-6", 2.5', 5' VOLUME COLLECTED: 20g each

HEADSPACE READINGS: not meas'd

DESCRIPTION OF SOIL MATERIALS:
med to dark brown silty soils with occasional clay nodules that are gray. typical to observe fuel sheen & degraded fuel odor. H₂O at 2-2.5' in SS05, SBO1, & SBO2; at 4-5' in new1; not encountered in new2. Permafrost was encountered in new2 at
 FIELD TEST KIT SCREENING TPH: _____ PCB: X
Aroclor 1260 4-5' Bedrock

SAMPLE IDS: _____ RESULTS: at 5' in new1

SBO1 - same location as 1994	Surf->10, <40; 2.5'->40; 5' - ND
SBO2 - "	surf. > 40; 2.5'>40; 5' ->40
SS05 - "	surf. > 40; 2.5' >1, <10; 5' - NA
New1 - 20' SE of SBO2	surf. >10, <40; 2.5' - ND; 5' - NA
New2 - 35' SE of pond	surf ND; 2.5' ND; 5' - NA

Detection limits 1, 10, 40 ppm
 DATE AND TIME OF TEST KIT SCREENING 8/9 7-10:30 and 8/10 8-9 am

COMPLETED BY:
Sarah Brown Sarah Brown SB 8/10/95
 PRINT NAME SIGNATURE DATE

CHECKED BY:

 PRINT NAME SIGNATURE DATE

SURFACE AND SUBSURFACE SOIL SAMPLING FIELD DATA FORM

PROJECT NAME: INDIAN MOUNTAIN LRRS Loc ID OT08-SS10
 PROJECT NUMBER: 05G46200
 SITE ID: OT08 IN-A100201
 SAMPLE ID: SO-OT08-SS10 and LOT CONTROL NO. IN-A100301
 DATE: 8/11/95 SO-OT08-SB04 TIME: 1221 ± 1224 (1228 on
 WEATHER: Overcast, 50°F CCC.)
 FIELD SAMPLING TEAM: S. Brown, R. Henry

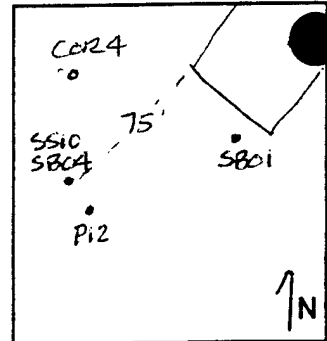

SAMPLING LOCATION: Lab samples collected from 0.5-1' and 2.5-3.0' depths
Approx. 80' west of SB01 ± 60' south of COR24
marker.

COMPOSITE: YES/NO Collection of soils from
 COMPOSITE DESCRIPTION: each interval, between rocks
 DEPTH OF SAMPLING INTERVAL: 0.5-1', 2.5-3' VOLUME COLLECTED: 1-4oz for each lab sample
and 4.5-5' ± 20g for each test kit
 HEADSPACE READINGS: _____ all for PCB analysis

DESCRIPTION OF SOIL MATERIALS:
Permafrost and fractured bedrock were encountered at 5' bgs.
No major water seepage observed. Gray, silty soil with
50% gravel and boulders.

FIELD TEST KIT SCREENING TPH: _____ PCB: X Aroclor 1260

SAMPLE IDs:	RESULTS:
SS10-01	ND
SS10-02	ND
SS10-03	ND
	ND = not detected

DATE AND TIME OF TEST KIT SCREENING 8/11 ± 8/12/95

COMPLETED BY:
Sarah Brown Sarah Brown 8/11/95
 PRINT NAME SIGNATURE DATE

CHECKED BY:

 PRINT NAME SIGNATURE DATE

SURFACE AND SUBSURFACE SOIL SAMPLING FIELD DATA FORM

PROJECT NAME: INDIAN MOUNTAIN LRRS
 PROJECT NUMBER: 05G46200 LOC ID 0T08-SS11
 SITE ID: 0T08
 SAMPLE ID: 50-0T08-SB05 LOT CONTROL NO. IN-A100401
 DATE: 8/11/95 TIME: 1247 (1250 on COC)
 WEATHER: Overcast, 50°F
 FIELD SAMPLING TEAM: S. Brown, R. Henry

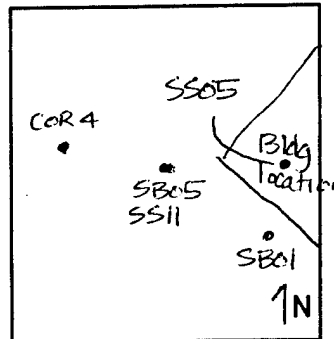

SAMPLING LOCATION: Lab sample collected from 2.5-3' depth east of COR 4 and west of SS05 (1994 location)

COMPOSITE: YES / NO COMPOSITE DESCRIPTION: collection of soils at the specific depths.
 DEPTH OF SAMPLING INTERVAL: 0.5-1', 2.5-3' and 4.5-5' VOLUME COLLECTED: 1.4oz jar for lab
 HEADSPACE READINGS: _____ 1.20g sample for test kits
 DESCRIPTION OF SOIL MATERIALS: _____ -all for PCB analysis

Soil/rock composition^{SP} is similar to other pits. Permafrost and fractured bedrock were encountered at 5' bgs. Soil became moist and 4.5'. Very rocky throughout pit.

FIELD TEST KIT SCREENING TPH: _____ PCB: X Aroclor 1260

SAMPLE IDS:	RESULTS:
SS11-01	> 1, < 10 ppm
SS11-02	ND
SS11-03	NA
	ND = not detected NA = not analyzed

DATE AND TIME OF TEST KIT SCREENING 8/11/95

COMPLETED BY:
Sarah Brown Sarah Brown 8/11/95
 PRINT NAME SIGNATURE DATE

CHECKED BY:

 PRINT NAME SIGNATURE DATE

SURFACE AND SUBSURFACE SOIL SAMPLING FIELD DATA FORM

PROJECT NAME: INDIAN MOUNTAIN LRRS
 PROJECT NUMBER: 05G46200 LOC ID 0T08-SS13
 SITE ID: 0T08 IN-A100601
 SAMPLE ID: SO-0T08-SS13 LOT CONTROL NO. IN-A100701
 DATE: 8/11/95 and SO-0T08-SB06 TIME: 1326 & 1332
 WEATHER: overcast 50°F
 FIELD SAMPLING TEAM: S Brown and R. Henry

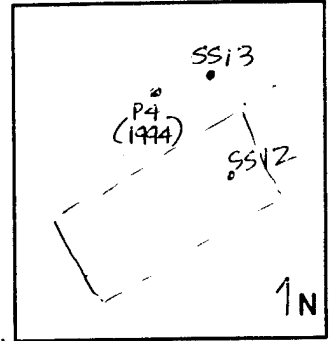

SAMPLING LOCATION: Lab samples collected from 0.5-1' and 2.5-3' bgs
NW side of 0T08 and 1994 location SS01.
NW of diversion ditch.

COMPOSITE: YES/NO COMPOSITE DESCRIPTION: Soils were composited at each interval
 DEPTH OF SAMPLING INTERVAL: 0.5-1', 2.5-3', and 4.5-5' VOLUME COLLECTED: 1-4oz for each lab sample and 20g for test kits - all for PCB analysis
 HEADSPACE READINGS: _____

DESCRIPTION OF SOIL MATERIALS:
Heavy degraded fuel odor and sheen on gray silty/clayey soils containing 70% gravel and small boulders. water was encountered about 4' bgs Six inches of peat material at surface

FIELD TEST KIT SCREENING TPH: _____ PCB: X Arcebor 1760

SAMPLE IDS:	RESULTS:
<u>SS13-01</u>	<u>ND</u>
<u>SS13-02</u>	<u>ND</u>
<u>SS13-03</u>	<u>NA</u>
	<u>ND = not detected</u>
	<u>NA = not analyzed</u>

DATE AND TIME OF TEST KIT SCREENING 8/11/95

COMPLETED BY:
Sarah Brown Sarah Brown 8/11/95
 PRINT NAME SIGNATURE DATE

CHECKED BY:

 PRINT NAME SIGNATURE DATE