

95-18

CRREL REPORT

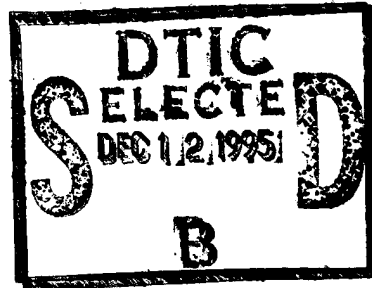

DISTRIBUTION STATEMENT A
Approved for public release
Distribution Unlimited



Efficiency of Steam and Hot Water Heat Distribution Systems

Gary Phetteplace

September 1995



Abstract

This report will provide some general guidance on the selection of distribution medium (steam or hot water) and temperature for heat distribution systems. The report discusses the efficiency of both steam and hot water heat distribution systems in more detail. The results of several field studies using data from boiler plant logs and measured heat losses are given. For steam, an efficiency analysis for the steam heat distribution system at Hawthorne Army Ammunition Plant is summarized. This analysis is based on the limited data available from the boiler logs maintained at the central plant. From this information, along with energy and mass balances that are constructed from the central plant data, gross measures of efficiency are obtained. The results of the analysis show that only 43.5% of the steam input to the distribution system is used to meet the required space heating load. The results also indicate that on average only 46.2% of the steam that leaves the plant returns as condensate. By converting this steam distribution system to a low temperature hot water heat distribution system, savings would exceed \$292,000 for the 181-day study period, which represents a typical heating season. For hot water based systems this report describes two field projects underway at U.S. Army bases. At Fort Jackson, South Carolina, a medium-temperature hot water heat distribution system has been monitored. Three different types of system construction have been instrumented: pipes enclosed in a shallow concrete trench, steel conduit with supply and return pipes in common conduit, and separate steel conduits for supply and return pipes. At Ft. Irwin, California, a low-temperature hot water system has been monitored. Two sites have been instrumented on this direct buried system that consists of steel carrier pipes insulated with polyurethane foam protected by a fiberglass jacket. The data provide a clear illustration of the much lower heat losses from the low temperature water systems.

Cover: Simplicity of the low temperature heat distribution system (bottom); complexity of high temperature heat distribution system (top).

For conversion of SI units to non-SI units of measurement consult ASTM Standard E380-93, *Standard Practice for Use of the International System of Units*, published by the American Society for Testing and Materials, 1916 Race St., Philadelphia, Pa. 19103.

CRREL Report 95-18



**US Army Corps
of Engineers**

Cold Regions Research &
Engineering Laboratory

Efficiency of Steam and Hot Water Heat Distribution Systems

Gary Phetteplace

September 1995

Prepared for
OFFICE OF THE CHIEF OF ENGINEERS

Approved for public release; distribution is unlimited.

PREFACE

This report was prepared by Gary Phetteplace, Mechanical Engineer of the Applied Research Division, Research and Engineering Directorate, U.S. Army Cold Regions Research and Engineering Laboratory, Hanover, New Hampshire. Funding was provided by DA Project 4A762784AT42, *Research in Snow, Ice and Frozen Ground*, Task CO, Work Unit M06. The author thanks Barry Coutermarsh and Herbert Ueda of CRREL for technical review of the manuscript.

This field work was primarily sponsored by the Army's Facilities Engineering Applications Program (FEAP), which seeks to demonstrate and facilitate the implementation of appropriate commercially available technologies for Army facilities. The author acknowledges the support of Bernie Wasserman of the Army's Center for Public Works, Satish Sharma of the Office of the Assistant Chief of Staff for Installation Management, and Dale Otterness, Headquarters U.S. Army Corps of Engineers, in obtaining funding for this study. Frank Hall, U.S. Army Corps of Engineers Area Office at Ft. Jackson, provided a great deal of assistance in installing and maintaining the equipment. Neil Lowell, Eric Swedberg, and Jim Blodgett all of the U.S. Army Corps of Engineers Sacramento District provided assistance on both the Ft. Irwin and Hawthorne AAP studies. The Hawthorne AAP studies were aided by Minnie Williams and Alfred Bandoni of the Directorate of Engineering and Housing office. At Ft. Irwin, Orvie Dahl of the Directorate of Engineering and Housing, as well as several people from the Area Office of the U.S. Army Corps of Engineers, Sacramento District, provided us with support. David Carbee of CRREL has been responsible for most of the data acquisition from these sites. Much of the data reduction was conducted by Rosanne Stoops and John Bement of CRREL.

The contents of this report are not to be used for advertising or promotional purposes. Citation of brand names does not constitute an official endorsement or approval of the use of such commercial products.

Accession For	
DTIC GRA&I	
DTIC TAB	
Unannounced	
Justification	
By _____	
Distribution/	
Availability Codes	
Dist	Avail and/or Special
A-1	

PREFACE

This report was prepared by Gary Phetteplace, Mechanical Engineer of the Applied Research Division, Research and Engineering Directorate, U.S. Army Cold Regions Research and Engineering Laboratory, Hanover, New Hampshire. Funding was provided by DA Project 4A762784AT42, *Research in Snow, Ice and Frozen Ground*, Task CO, Work Unit M06. The author thanks Barry Coutermarsh and Herbert Ueda of CRREL for technical review of the manuscript.

This field work was primarily sponsored by the Army's Facilities Engineering Applications Program (FEAP), which seeks to demonstrate and facilitate the implementation of appropriate commercially available technologies for Army facilities. The author acknowledges the support of Bernie Wasserman of the Army's Center for Public Works, Satish Sharma of the Office of the Assistant Chief of Staff for Installation Management, and Dale Otterness, Headquarters U.S. Army Corps of Engineers, in obtaining funding for this study. Frank Hall, U.S. Army Corps of Engineers Area Office at Ft. Jackson, provided a great deal of assistance in installing and maintaining the equipment. Neil Lowell, Eric Swedberg, and Jim Blodgett all of the U.S. Army Corps of Engineers Sacramento District provided assistance on both the Ft. Irwin and Hawthorne AAP studies. The Hawthorne AAP studies were aided by Minnie Williams and Alfred Bandoni of the Directorate of Engineering and Housing office. At Ft. Irwin, Orvie Dahl of the Directorate of Engineering and Housing, as well as several people from the Area Office of the U.S. Army Corps of Engineers, Sacramento District, provided us with support. David Carbee of CRREL has been responsible for most of the data acquisition from these sites. Much of the data reduction was conducted by Rosanne Stoops and John Bement of CRREL.

The contents of this report are not to be used for advertising or promotional purposes. Citation of brand names does not constitute an official endorsement or approval of the use of such commercial products.

CONTENTS

	Page
Preface	ii
Introduction	1
Design considerations for heat distribution systems	1
Distributed media selection	2
Low temperature water design issues	3
Efficiency analysis of a stream heat distribution system	5
Heat generation and distribution at Hawthorne AAP	5
Heating loads on the Hawthorne AAP system	6
Results for the Hawthorne system	7
Conclusions regarding the Hawthorne AAP steam system	11
Heat loss measurements	13
MTHW common conduit system	13
MTHW individual conduit system	13
MTHW shallow concrete trench system	13
LTHW preinsulated system, site 1	14
LTHW preinsulated system, site 2	14
Instrumentation, data logging and communication systems	15
Data analysis	15
Insulation method	15
Soil method, one pipe or conduit	17
Method for two buried pipes in individual conduits	17
Method for two pipes buried in a common conduit	17
Soil method for two direct buried pipes	17
Results of heat loss measurements	17
MTHW trench site	17
MTHW common conduit site	18
MTHW individual conduit site	19
LTHW preinsulated system, site 1	20
LTHW preinsulated system, site 2	21
Conclusions drawn from heat loss measurements	22
Conclusions	23
Selected bibliography	23
Abstract	25

ILLUSTRATIONS

Figure

1. An example of temperature and flow rate modulation	4
2. Steam flow from the plant as a function of degree days	7
3. Adjusted average makeup flow rate as a function of degree days	10
4. Adjusted makeup rate as a function of degree days	11
5. Construction details for the MTHW common conduit site	13
6. Construction details for the MTHW individual conduit site	13
7. Construction details for the MTHW trench site	14
8. Construction details for the LTHW site 1	14
9. Construction details for the LTHW site 2	15

Figure	Page
10. Heat losses for the MTHW trench site	18
11. Heat losses from the MTHW common conduit site	19
12. Heat losses from the MTHW individual conduit system	20
13. Heat losses from the LTHW site 1 system	21
14. Heat losses from the LTHW site 2 system	22

TABLES

Table

1. Sample data and calculated results for the Hawthorne AAP steam system ..	8
2. Averages of some calculated and measured values for the study sites	16

Efficiency of Steam and Hot Water Heat Distribution Systems

GARY PHETTEPLACE

INTRODUCTION

Most major Department of Defense (DoD) facilities are heated using central heat distribution systems. The heat from the central heating plants usually is distributed to the buildings as high-temperature hot water or steam through buried piping systems. DoD has approximately 10,000 km (6000 mi) of heat distribution piping systems in service (Segan and Chen 1984). Many of these systems are old and in need of major repairs or replacement. To replace these systems currently costs about \$1000/lineal m (\$300/lineal ft). Thus, the DoD is facing monumental costs for replacement. In addition, the technology currently being used by DoD is problematic. Many systems that have been recently replaced have failed prematurely. A previous study done by the Corps of Engineers (Segan and Chen 1984) identified many problems caused by improper design, installation, and maintenance. Most of these problems led to premature failure of the systems. For the Army's 1992 fiscal year the annual maintenance costs were over \$24 million (U.S. Army 1992). This does not include any of the larger replacement projects. In addition, as will be shown later, the cost of heat loss is much greater.

In an effort to reduce the installation and operating cost of these systems, the Army has an active research and development program in heat distribution technology. The objective of DoD heat distribution research is to identify improvements in methods and systems that will prove to be less costly and problematic. This report gives sample results from several of the Army's research projects.

One of the major components of the Army's heat distribution research is the accurate assessment of heat losses. As well as being an essential part of the design of these systems, determination of heat losses is a primary factor in making repair/replace deci-

sions. If we assume an optimistic value for average heat loss from current systems of 48 W/m (50 Btu/hr-ft) (for older systems and those with large pipes, greater than 4 in. or 100 mm, a value of several times this is likely) and a cost of \$9.48/GJ (\$10/million Btu's) for heat energy, we find that heat losses cost the Army around \$85 million per year. Before giving details on several of the heat distribution efficiency studies that CRREL has done, we will outline some of the basic design considerations for these systems.

DESIGN CONSIDERATIONS FOR HEAT DISTRIBUTION SYSTEMS

The design of heat distribution systems is much more complicated than the design of other piped utilities such as potable water and sewage systems. Because of the need to conserve thermal energy as well as the hot water or steam itself, the systems become much more complicated and costly, from both the installed cost and operations and maintenance standpoints. The major challenge in the design of heat distribution systems is keeping the thermal insulation dry so that it remains effective. This becomes a formidable task because the system is usually buried in the ground, which is frequently saturated with water, and it is carrying water inside the pipe. Fortunately, the heated pipes tend to drive moisture out of the insulation. Unfortunately, the elevated temperatures accelerate corrosion as well, which tends to increase the frequency of leaks. Leaks are very costly in heat distribution systems because not only is the treated water itself costly, but the thermal energy contained in the water is also lost when a leak exists.

Thus, the design of heat distribution systems requires careful examination of the alternatives once the site conditions and project requirements are

known. Some of the basic issues that impact distribution system efficiency are addressed below. For a more complete discussion of the issues and alternatives Phetteplace and Meyer (1990) and ASHRAE (1992) should be consulted.

Distributed media selection

District heating began in the United States in the late 19th century. These early systems used steam as the heat-carrying medium. The steam-based systems thrived with the inexpensive energy prices of the time and many systems were built, with a large number of them still operational today. The very high load density of the densely developed downtown areas these steam systems serve allows them to tolerate the large distribution losses and even today remain competitive with alternative means of building heating.

After World War II many district heating systems were built in European cities. Both steam and hot water-based systems were built. As the technology for the hot water systems evolved, it became clear that they were a good alternative to the steam systems. The hot water systems eliminated the problems of condensate handling and were easier to control than the steam systems. Thus, most systems built in Europe after the war were hot water based. This technology was brought to the United States in the early 1950s and a number of hot-water based systems were built in the United States, particularly on DoD facilities. These systems used pressurized water at temperatures above 175°C (350°F) in most cases. Hot water systems are normally broken into three temperature classes. Systems with supply temperatures over approximately 175°C (350°F) are usually considered to be high temperature hot water (HTHW) systems. Medium temperature hot water (MTHW) systems have supply temperatures in the range of 120 to 175°C (250 to 350°F). Low temperature hot water (LTHW) systems have supply temperatures of 120°C (250°F) or lower. In practice, the return temperature from all these types of systems varies widely, with the higher temperature systems tending to have higher return temperatures. Achieving a large temperature difference between supply and return is desirable because this reduces the amount of water that needs to be circulated for a given heat delivered.

While the high temperature hot water systems proved to be much less problematic than steam systems, they still suffered from relatively high levels of heat loss, as well as other problems associated with elevated temperatures and pressures. However, with energy costs still low, they offered a good compro-

mise because large temperature differentials could be achieved and thus mass flow rates and pipe sizes remained lower than was possible with water at lower temperatures. With low temperature hot water it would have been more difficult to achieve temperature differentials of the same magnitude with the heat exchanger technology of the time. In Europe, however, energy costs were higher and lower temperatures were shown to offer lower life cycle costs, particularly since the lower temperatures were much more favorable for cogeneration of heat and electricity. A number of other material developments, such as suitable nonmetallic jacket materials and polyurethane foam insulation, applicable only to lower temperature systems, further widened the advantage these systems held. These materials either were not able to withstand the higher temperatures or degraded very rapidly under such conditions. Currently nearly all systems in Europe use low temperature hot water. Such systems have been so successful in Europe that the market penetration is very high, for example, approximately 50% in Denmark and Finland. The major advantage that low temperature water holds with regard to heat losses is best illustrated by actual field measurements made on low temperature hot water and medium temperature hot water systems installed on Army bases. A study that made such measurements is described later in this report.

Regardless of whether steam or hot water is chosen, the temperature and pressures used should be only as high as required to satisfy the requirements of the consumers. This cannot be overemphasized. Higher temperatures result in higher heat losses, as will be shown from the data presented later. In addition, higher temperatures and pressures result in numerous other problems such as accelerated corrosion, higher rates of leakage, and lower safety and comfort levels for operators and maintenance personnel. Higher temperatures also may require higher pressure ratings for piping and fittings and, in addition, may preclude the use of desirable materials such as polyurethane foam insulation and non-metallic conduits. For hot water systems it is important to design for a high temperature drop at the consumer. This reduces the flow rate through the system and thus the pumping power required. Higher temperature drops at the consumer also result in lower return temperatures, which in turn result in lower return line heat loss, as the data to be presented will show.

Although hot water is widely regarded as the best alternative where either medium will meet the requirements, in many instances existing equipment

and processes will require the use of steam. Some common examples of where steam may be required on DoD installations are laundry facilities, mess halls, motor pools, and hospitals. A careful study should be made of the alternatives before selecting the distribution medium and temperature. A list of common attributes with a brief discussion of the relative merits of each medium is given below.

Heat capacity

Steam has a distinct advantage as it relies primarily on the latent heat of water rather than the sensible heat. The net heat effect for saturated steam at 6.9 bars (100 psig) (170°C or 338 °F) condensed and cooled to 82°C (180°F) is approximately 2.42 mJ/kg (1040 Btu/lbm). For hot water cooled from 175° to 120°C (350° to 250°F) the net heat effect is 0.24 mJ/kg (103 Btu/lbm), or only about 10% as much. Thus, a hot water system must circulate about 10 times more mass than a steam system of similar heat capacity.

Pipe sizes

Although much less mass of steam is required for a given heat load, steam usually requires a larger pipe size for the supply line due to its lower density. This is compensated by a much smaller condensate return pipe. Piping costs for steam and condensate, as opposed to hot water supply and return, are comparable. With regard to the temperature level in hot water systems, given an equal temperature difference between supply and return, the temperature level of the supply will have no effect on the mass flow rate. Thus, aside from any minor effects caused by viscosity and density differences, a low temperature water system with a temperature difference of 55°C (100°F) will have the same size pipes as a high temperature system with a temperature difference of 55°C (100°F). Because the heat can be used only down to some practical lower limit of temperature, low temperature hot water systems may not have as high values of temperature difference between supply and return. Thus, if temperature difference were the only consideration, higher temperature hot water systems would be favored. However, when the increased heat losses, maintenance and system complexity that result from higher temperatures is considered, lower hot water temperatures become more favorable. With proper design they will not require significantly larger piping.

Return system

Condensate return systems have proven to be very problematic. Corrosion of the piping is a major

problem. Nonmetallic piping has been used with only limited success. For these reasons condensate was seldom returned from older systems. However, at current energy costs it becomes imperative to do so. Condensate drainage systems (steam traps, condensate pumps, and receiver tanks) have also proven to be problematic, corrosion again being one of the major sources of problems. Although much developmental effort has been expended on steam traps, the best designs today still have a relatively short (less than five years) life expectancy and will leak several pounds per hour of steam in the closed condition even when new. In summary, problems in condensate collection and return are the major disadvantages of steam systems.

Pressure requirements

Flowing steam and hot water both incur pressure losses. Hot water systems may use intermediate booster pumps to increase the pressure at points between the plant and the consumer. Pressure variations due to elevation differences within hot water systems are much greater than for steam systems due to the higher density of water. This can adversely affect the economics of a hot water system by requiring the use of a higher pressure class of piping and/or booster pumps.

Low temperature water design issues

Because low temperature hot water systems are the least common system type in the United States, designers are often not as familiar with these systems. For this reason we will address a few issues with hopes of dispelling some common myths.

From a designer's perspective low temperature water systems are no more difficult, and in most cases simpler, than steam and high temperature water systems. Distribution system design is straightforward and is less complicated than steam or high temperature hot water because of the lower temperatures and pressures involved. Because of the high degree of standardization of these systems, a number of specialized components are available that simplify the design process.

Low temperature water is well suited to the gradual change-over of the distribution medium from steam or high temperature hot water. When major distribution replacement projects are under consideration, or a new area of a base or community is being expanded into, low temperature water can be used simply by putting a heat exchanger station between the existing network and the new low temperature system. In this way gradual conversion can

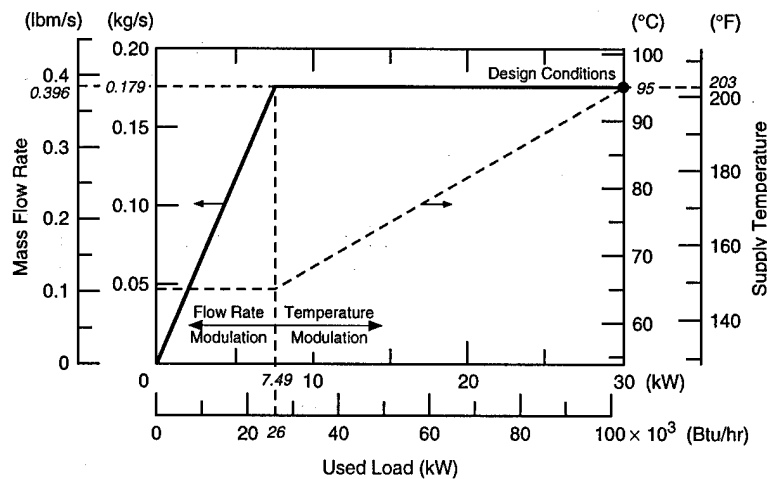

Figure 1. An example of temperature and flow rate modulation.

take place as portions of the distribution system are replaced, thus making the economics more attractive.

Despite their widespread acceptance in Europe and several successful recent installations in the United States, low temperature hot water systems are still associated with a number of myths. Some of the more commonly held misconceptions are described below.

Low temperatures are not suitable for large systems. One only needs to look at some of the enormous systems in Europe to be convinced that this is clearly not the case. For example, all of Copenhagen and the surrounding towns are tied into one big low temperature system. St. Paul, Minnesota, has a large system and several other towns in the United States have fairly large systems. Because of the high efficiency of urethane insulation and the lower temperatures, heat losses are low (approximately 5% of system capacity) and significant temperature drops during transport are simply not a problem. For example, consider the 150-mm (6-in.) LTHW system at Ft. Irwin, discussed in more detail later. The average heat loss from the supply pipe is only 20 W/m (21 Btu/hr-ft) (Phetteplace 1992). If a modest flow velocity of 1.5 m/s (5 ft/s) is assumed the water in this supply pipe would experience a temperature drop of only about 0.3°C (0.6°F) over a transport distance of one mile.

Low temperature systems require much larger piping. As stated earlier, for a given flow rate, the amount of heat conveyed depends only on the temperature difference between supply and return, not the absolute value of the supply temperature. With proper design, low temperature water systems can and do

achieve temperature differences of 55°C (100°F), just like medium and high temperature water systems. Low temperatures and pressures make it easier to control the building space heating and domestic hot water heating systems; thus, it is easier to maintain significant temperature differences between supply and return even in times of lower load. In larger systems, the flow rate is usually modulated along with the temperature in order to meet the varying load conditions while keeping the cost of pumping and heat losses as low as possible. The temperature modulation is done in a manner similar to the way the temperature of hydronic heating systems in buildings are reset based on outdoor air temperature. An example of temperature and flow rate modulation is given in Figure 1 (from Phetteplace and Labbe 1978).

Even when temperature differences between supply and return are somewhat smaller, pipe sizes do not need to be increased significantly. For example, consider the Ft. Irwin LTHW system and the Ft. Jackson MTHW system, which will be discussed in more detail later. Assume a flow velocity of 1.5 m/s (5 ft/s) in each system and a temperature difference of 36°C (65°F) for the LTHW system and 55°C (100°F) for the MTHW system. The heat conveyed by the MTHW system with 125-mm (5-in.) piping is about 3.81 MW (13.0 MBtu/hr). For the LTHW system with 150-mm (6-in.) piping the heat conveyed is only slightly lower at 3.72 MW (12.7 MBtu/hr). Despite the fact that the flow rate in the LTHW system would need to be about 50% higher than for the MTHW system, the pumping energy costs would only be about 25% higher as a result of the larger pipe size. Pumping energy is usually a

small portion of the delivered energy (2–5%), so this additional cost is insignificant when compared to the greatly reduced heat losses.

Low temperature systems require larger heat exchangers. This is true; however, it does not become a major disadvantage for several reasons. Because of the lower temperatures, it is often possible to eliminate the need for heat exchangers for building heating altogether. Since higher temperatures must ultimately be reduced within the building systems under most circumstances, lower supply temperature is seldom a problem in space heating applications. If heat exchangers are needed or desired for isolation purposes, larger buildings can use plate-and-frame heat exchangers which, because of their large surface area to volume ratios, are economical for LTHW applications. For domestic hot water production, careful design of the heat exchange system can yield a very close approach temperature between the LTHW supply and the delivered domestic hot water, again eliminating any problems with inadequate temperature at the end user. In smaller buildings, "brazed" heat exchangers, which are very similar to plate and frame units except they cannot be disassembled, are becoming very popular in Europe because of their low cost and extreme compactness. For example, a stainless steel brazed heat exchanger including preformed insulation, for a residential size application is about the size of a lunch box, and would cost about \$200.

The large surface area to volume ratios which can be achieved in plate type heat exchangers make their performance impressive. Consider, for example, a typical design for a brazed plate unit that might be used on a small space heating or domestic water heating load of about 20 kW (70,000 Btu/hr). With a primary water supply temperature of 120°C (250°F) and design secondary side temperatures of 90°C (195°F) supply and 70°C (160°F) return, the approach temperature would be less than 0.5°C (1°F). This means that the primary return water would be at about 70.5°C (161°F), within 0.5°C (1°F) of the theoretical minimum of the entering secondary water temperature. The flow rates through the heat exchanger would be about 6 liters/min (1.6 gpm) on the primary side and 14.8 liters/min (3.9 gpm) on the secondary side. Pressure losses would be about 34.5 kPa (0.5 psi) on the primary side and 145 kPa (2.1 psi) on the secondary side. The heat exchanger used for this sample design would be about 53.3 cm (21 in.) long, 11.4 cm (4.5 in.) wide, and 4.1 cm (1.6 in.) thick with 14 plates and an empty weight of less than 5.4 kg (12 lb).

The above discussion clearly illustrates that low

temperature hot water is a feasible, and in most cases, desirable heat distribution medium for DoD facilities. When new systems or major replacement projects are planned, serious consideration should be given to this technology.

To illustrate the efficiency of several types of heat distribution we will present results from several field studies conducted by CRREL over the last few years. First we will discuss an efficiency analysis conducted on a steam system at Hawthorne AAP.

EFFICIENCY ANALYSIS OF A STEAM HEAT DISTRIBUTION SYSTEM

The following efficiency analysis was conducted on data obtained from Hawthorne Army Ammunition Plant (Hawthorne AAP). This facility is located in Mineral County, Nevada, about 220 km (135 mi) southeast of Reno. Hawthorne AAP is located in a high desert region 1276 m (4,186 ft) above sea level. The 99% dry bulb heating design temperature is -13.9°C (7°F) and the 97.5% dry bulb heating design temperature is -11.7°C (11°F) (U.S. Army 1978). This climate accumulates 3060°C-days (18.3°C base) (5508°F-days, 65°F base) during an average heating season (U.S. Army 1978).

The compound of Hawthorne AAP covers about 5.87×10^8 m² (145,000 acres) and has 2,873 buildings. The land and buildings can be divided into two categories: industrial and ordnance. This study addresses only the buildings in the industrial area of Hawthorne AAP. These buildings consist of offices, shops, housing units, and recreational and other facilities. Most of these buildings are heated by steam from a central distribution system. The steam is generated in a central plant using fuel-oil-fired boilers. The conversion of this central heat distribution system from steam to low temperature hot water was the subject of a detailed study (Phetteplace 1991a).

Heat generation and distribution at Hawthorne AAP

The existing steam distribution system at Hawthorne AAP consists of a steam supply line and a condensate return line. The distance along the steam line from the central plant to the most distant consumer is less than 1 mile. The steam pressure is normally around 6.9 bars gage (100 psig) at the entrance to the distribution system. This pressure is reduced in the buildings to a nominal 1 bar (15 psig). In the housing area, a central pressure reducing station reduces the pressure to approximately 0.34 bars

gage (5 psig) before distribution to the individual family housing units.

Most of the main steam lines for the distribution system are contained in shallow concrete trenches whose covers are at grade level and used as sidewalks. A small portion of the steam distribution piping is directly buried in either steel conduit systems or loose fill insulation materials. For a more detailed description of the construction details for these types of systems, see Phetteplace and Meyer (1990). In most all cases the condensate return piping is routed entirely independently of the steam piping. Most of the return piping is buried directly in the soil and is uninsulated brass or steel piping. The condensate return is by gravity in most places. An unusual arrangement called a "sand pit" is used in the condensate return system. The sand pits resemble sewer manholes in that the incoming condensate flows into a concrete basin and then out into the outflow piping at the level of the condensate in the sand pit. Unlike a sewer manhole, the bottom of the sand pit is not concrete but is formed by the native sandy soil. To the extent that this soil is not clogged with particulates, the condensate is allowed to percolate into it. This arrangement may account for a significant portion of the mass loss from the distribution system, as will be discussed later.

Very few of the buildings at Hawthorne AAP are equipped to use steam from the central system to heat hot water for domestic uses. Electric hot water heaters are used in most cases. The notable exceptions to this are two apartment buildings that have large hot water storage tanks in their basements. These are equipped with steam heat exchangers as well as electric heating elements. Although steam has heated these tanks in the past, the electric heaters were in use at the time of our study. Personnel from the operating contractor indicated that the electric heaters have been used exclusively in recent years. Earlier they had been operated only when the heat distribution system was not in operation.

At the time of our analysis the operating policy was to turn off the central steam distribution system and the heating plant during times of low load. A portion of the system that serves a residential section of the base was sometimes shut down prior to the remainder of the system. The entire system was shut down for the summer months and was occasionally shut down and restarted during the "swing" periods of the fall and the spring seasons as well. This practice was instituted several years earlier by the operating contractor as an energy conservation measure. Because the system is not used to generate domestic hot water, this presents no problem from a heat supply standpoint. Al-

though no evidence of increased maintenance on the boiler plant equipment or distribution system was apparent to the operators at the time of the study, the long-term effect due to thermal cycling of the system is likely to be detrimental.

All of the boilers are fired with no. 2 fuel oil, which is delivered by truck and stored in several large holding tanks. Measurements on the boilers using combustion analysis have shown the efficiency to be around 85%. No steam flow data from the central plant are available due to lack of a functional flow meter. The individual buildings are not equipped with flow meters, consistent with standard practice on most DoD installations. Daily boiler logs are maintained for the heating plant. These boiler logs contain various temperature and pressure readings taken on a hourly basis. Records of daily fuel used, in storage, and delivered are maintained on the boiler logs as well. By using limited data available from the boiler logs with heat and mass balances for the system and some statistical analysis, we can find some estimates of the losses in which we are reasonably confident. The details on the development of the model used for this purpose are given in Phetteplace (1991a).

Heating loads on the Hawthorne AAP system

Without meters on the buildings or at the plant it becomes necessary to estimate the heating load on the system from weather data. The concept of the heating degree day has been used extensively for this purpose. Details on its use can be found in ASHRAE (1985). For the purposes of this analysis we need only to assume that the heating energy required over a specified period of time is proportional to the degree days accumulated over that same period of time. Werner (1984) proposes a much more detailed model of the heat load in district heating systems. From his study of the degree-day concept he concludes that it "... does not accurately explain the composition of the space heating demand." Although it is agreed that the degree-day concept does not accurately account for such factors as solar gain and infiltration, we feel that for the purposes of an efficiency analysis such as this, its use is acceptable as an alternative to more complicated models such as those proposed by Werner (1984). Data from a fairly large (approximately 75-MW or, 255 MBtu/hr) steam district heating system on Ft. Wainwright, Alaska, (Phetteplace et al. 1981) indicate that it does track the heat load reasonably well if the effects of the distribution system losses and domestic tap water heating are considered.

For residential and office buildings normally

heated to about 21°C (70°F) the base temperature for the degree day calculation is taken as 18.3°C (65°F). For other types of buildings that are not heated to as high a level, lower base temperatures can be used. The portion of Hawthorne AAP under study had residential and office buildings that would normally be heated to about 21°C (70°F) as well as shop type buildings that would not be heated to as high a level. In order to more accurately model the energy use of the shop buildings, a base temperature of 12.8°C (55°F) was used for these buildings. The degree days were calculated on a daily basis for each of the two base temperatures. These were then combined by forming a weighted average of the two degree-day figures obtained. The weighting factors used were determined by taking the relative fraction of total floor area comprised by each building type. The floor area of the residential and office buildings comprised 63.2% of the total heated floor area and the remaining 36.8% was from shop buildings. For the month of December 1987 the degree days computed for each of the two base temperatures, as well as the weighted average, are presented in Table 1.

Results for the Hawthorne system

For each of the 181 days of the continuous period of boiler operation in the 1987/88 heating season, the quantities in Table 1 were either measured or calculated based on formulas presented in Phetteplace (1991a). The measured data were input manually into a commercially available spreadsheet program, which was used to calculate the remaining quantities. This information was then transferred to

a commercially available statistical/graphical software package where the remaining analysis was performed.

The first set of results we will present is intended to enforce the premise that the heating degree day data provides a reasonable representation of the heat load from the buildings. Figure 2 shows the average steam flow rate from the plant as a function of the weighted average of the heating degree-day data. Although there is considerable scatter in these data, they clearly support the concept of the degree day. The r^2 value for the linear relationship that was fitted to the data is 72%. Since this is the total steam flow from the plant, it represents all the losses from the system that would be manifested by steam consumption as well as all energy consumption at the buildings. The components that make up the total steam flow out of the plant are the following:

1. Leaks from the steam piping into the environment.
2. Heat losses from the steam lines that cause the saturated steam to condense. The condensate is then subsequently drained from the steam pipe and passes through a steam trap into the condensate return system.
3. The heating load in the building that causes steam to be condensed to meet this load. Then the condensate passes through steam traps into the condensate return system. During the time period when our data were collected, no steam was used for domestic tapwater heating.

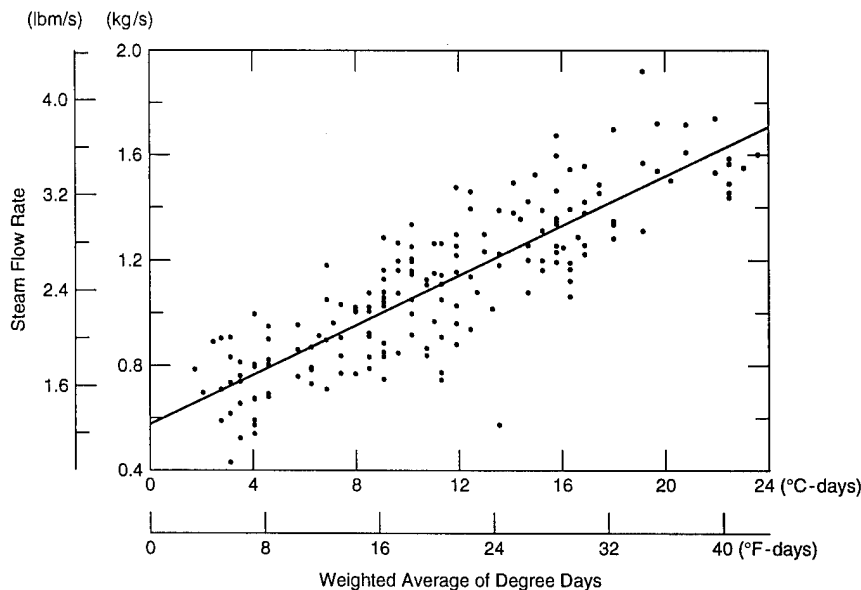

Figure 2. Steam flow from the plant as a function of degree days.

Table 1. Sample data and calculated results for the Hawthorne AAP steam system.

Date	Julian date	Avg. air temp °C (°F)	Degree days		Weighted average DD °C-day (°F-day)	Fuel use L/hr (gal./hr)	Make-up flow kg/sec (lbm/sec)	Heat rate kW (MBtu/hr)	Blow downs	Blow down rate kg/sec (lbm/sec)	Steam flow kg/sec (lbm/sec)	Make-up rate	Adjusted make-up rate
			18.3°C (65°F) base	12.8°C (55°F) base									
01 Dec 87	335	7.2 (44)	11.7 (21)	6.1 (11)	9.6 (17.3)	376 (99.4)	0.758 (1.67)	3451 (11.78)	3	0.0329 (0.072)	1.313 (2.895)	0.577	0.552
02 Dec 87	336	6.7 (45)	11.1 (20)	5.6 (10)	9.1 (16.3)	339 (89.5)	0.679 (1.50)	3108 (10.61)	3	0.0329 (0.072)	1.182 (2.606)	0.574	0.547
03 Dec 87	337	8.3 (47)	10.0 (18)	4.4 (8)	7.9 (14.3)	308 (81.3)	0.675 (1.49)	2825 (9.64)	3	0.0329 (0.072)	1.068 (2.354)	0.632	0.601
04 Dec 87	338	9.4 (49)	8.9 (16)	3.3 (6)	6.8 (12.3)	352 (92.9)	0.675 (1.49)	3227 (11.01)	3	0.0329 (0.072)	1.231 (2.713)	0.548	0.521
05 Dec 87	339	5.3 (41.5)	13.1 (23.5)	7.5 (13.5)	11.0 (19.8)	373 (98.5)	0.670 (1.48)	3421 (11.67)	3	0.0329 (0.072)	1.309 (2.887)	0.512	0.487
06 Dec 87	340	8.9 (48)	9.4 (17)	3.9 (7)	7.4 (13.3)	315 (83.2)	0.683 (1.51)	2890 (9.86)	3	0.0329 (0.072)	1.093 (2.410)	0.625	0.595
07 Dec 87	341	5.3 (41.5)	13.1 (23.5)	7.5 (13.5)	11.0 (19.8)	345 (91.1)	0.688 (1.52)	3165 (10.80)	3	0.0329 (0.072)	1.204 (2.655)	0.571	0.544
08 Dec 87	342	4.4 (40)	13.9 (25)	8.3 (15)	11.8 (21.3)	373 (98.6)	0.767 (1.69)	3424 (11.68)	3	0.0329 (0.072)	1.301 (2.868)	0.589	0.564
09 Dec 87	343	7.2 (45)	11.1 (20)	5.6 (10)	9.1 (16.3)	345 (91.1)	0.609 (1.34)	3165 (10.80)	3	0.0329 (0.072)	1.212 (2.673)	0.502	0.475
10 Dec 87	344	8.9 (48)	9.4 (17)	3.9 (7)	7.4 (13.3)	262 (69.1)	0.561 (1.24)	2401 (8.19)	3	0.0329 (0.072)	0.908 (2.002)	0.617	0.581
11 Dec 87	345	5.0 (41)	13.3 (24)	7.8 (14)	11.3 (20.3)	246 (64.9)	0.569 (1.26)	2254 (7.69)	3	0.0329 (0.072)	0.848 (1.870)	0.672	0.633
12 Dec 87	346	-1.7 (29)	20.0 (36)	14.4 (26)	17.9 (32.3)	394 (104.2)	0.644 (1.42)	3619 (12.35)	4	0.0438 (0.097)	1.391 (3.066)	0.463	0.432
13 Dec 87	347	-2.8 (27)	21.1 (38)	15.6 (28)	19.1 (34.3)	541 (142.9)	0.705 (1.55)	4962 (16.93)	6	0.0657 (0.145)	1.924 (4.242)	0.367	0.332
14 Dec 87	348	-6.1 (21)	24.4 (44)	18.9 (34)	22.4 (40.3)	460 (121.5)	0.788 (1.74)	4221 (14.40)	6	0.0657 (0.145)	1.616 (3.562)	0.488	0.447
15 Dec 87	349	-4.4 (24)	22.8 (41)	17.2 (31)	20.7 (37.3)	495 (130.8)	0.885 (1.95)	4544 (15.50)	6	0.0657 (0.145)	1.736 (3.828)	0.510	0.472
16 Dec 87	350	0.6 (33)	17.8 (32)	12.2 (22)	15.7 (28.3)	486 (128.3)	0.937 (2.07)	4457 (15.21)	6	0.0657 (0.145)	1.696 (3.739)	0.553	0.514
17 Dec 87	351	0.6 (33)	17.8 (32)	12.2 (22)	15.7 (28.3)	464 (122.5)	0.850 (1.87)	4256 (14.52)	6	0.0657 (0.145)	1.623 (3.579)	0.523	0.483
18 Dec 87	352	-0.6 (31)	18.9 (34)	13.3 (24)	16.8 (30.3)	452 (119.5)	0.780 (1.72)	4150 (14.16)	6	0.0657 (0.145)	1.588 (3.501)	0.491	0.450
19 Dec 87	353	0.6 (33)	17.8 (32)	12.2 (22)	15.7 (28.3)	400 (105.6)	0.841 (1.85)	3668 (12.52)	6	0.0657 (0.145)	1.386 (3.057)	0.607	0.559
20 Dec 87	354	-2.8 (27)	21.1 (38)	15.6 (28)	19.1 (34.3)	390 (102.9)	0.771 (1.70)	3574 (12.19)	6	0.0657 (0.145)	1.356 (2.989)	0.569	0.520
21 Dec 87	355	0.0 (32)	18.3 (33)	12.8 (23)	16.3 (29.3)	412 (108.8)	0.819 (1.81)	3778 (12.89)	6	0.0657 (0.145)	1.433 (3.160)	0.572	0.526
22 Dec 87	356	0.6 (33)	17.8 (32)	12.2 (22)	15.7 (28.3)	396 (104.7)	0.775 (1.71)	3635 (12.40)	6	0.0657 (0.145)	1.380 (3.042)	0.562	0.514
23 Dec 87	357	-3.9 (25)	22.2 (40)	16.7 (30)	20.2 (36.3)	440 (116.1)	0.828 (1.83)	4033 (13.76)	6	0.0657 (0.145)	1.535 (3.385)	0.539	0.496
24 Dec 87	358	-5.6 (22)	23.9 (43)	18.3 (33)	21.8 (39.3)	499 (131.8)	0.819 (1.81)	4578 (15.62)	6	0.0657 (0.145)	1.757 (3.874)	0.466	0.429
25 Dec 87	359	-7.2 (19)	25.6 (46)	20.0 (36)	23.5 (42.3)	465 (122.9)	0.828 (1.83)	4267 (14.56)	6	0.0657 (0.145)	1.630 (3.595)	0.508	0.468
26 Dec 87	360	-6.1 (21)	24.4 (44)	18.9 (34)	22.4 (40.3)	422 (111.5)	0.780 (1.72)	3874 (13.22)	6	0.0657 (0.145)	1.476 (3.254)	0.528	0.484
27 Dec 87	361	-4.4 (24)	22.8 (41)	17.2 (31)	20.7 (37.3)	465 (123.0)	0.793 (1.75)	4270 (14.57)	6	0.0657 (0.145)	1.635 (3.605)	0.485	0.445
28 Dec 87	362	-2.8 (27)	21.1 (38)	15.6 (28)	19.1 (34.3)	457 (120.8)	0.885 (1.95)	4196 (14.32)	6	0.0657 (0.145)	1.596 (3.518)	0.555	0.513
29 Dec 87	363	-3.3 (26)	21.7 (39)	16.1 (29)	19.6 (35.3)	451 (119.2)	0.898 (1.98)	4140 (14.13)	6	0.0657 (0.145)	1.571 (3.465)	0.571	0.530
30 Dec 87	364	0.0 (32)	18.3 (33)	12.8 (23)	16.3 (29.3)	450 (118.8)	0.810 (1.79)	4125 (14.08)	6	0.0657 (0.145)	1.575 (3.472)	0.515	0.473
31 Dec 87	365	-6.1 (21)	24.4 (44)	18.9 (34)	22.4 (40.3)	456 (120.5)	0.845 (1.86)	4183 (14.27)	6	0.0657 (0.145)	1.594 (3.516)	0.530	0.489
Totals		0.7 (33.2)	547 (985.0)	375.0 (675.0)	483.5 (870.3)	407 (108)	0.762 (1.680)	3737 (13)	151	0.0533 (0.118)	1.425 (3.141)	0.543	0.506
Averages			17.7 (31.8)	12.1 (21.8)	15.6 (28.1)				4.9				

The steam use due to leaks in the steam distribution piping is basically only a function of the pressure in the steam supply pipe. Since the supply pressure at the inlet to the distribution system is maintained at a reasonably constant level, the rate of steam leakage is also fairly constant. When higher loads are experienced at the buildings, the increased steam flow rate will result in greater pressure losses and thus the pressure will be lower under the higher load conditions. This effect will of course increase as the distance from the plant increases. The Hawthorne AAP system is a relatively small system with the longest distance along the pipe from plant to consumer being about 1035 m (3400 ft). For this reason, the amount of steam used due to leaks will be assumed to be essentially independent of the space heating load.

Steam use resulting from heat losses in the distribution system is a function of the temperature of the surroundings, and thus it is also correlated with the degree days accumulated. This function is basically proportional to the temperature difference between the steam in the pipe and the adjacent surroundings. Since most of the main steam lines are contained in concrete trenches whose covers are at grade level, there is little time lag between the time of an air temperature change and the time at which the steam system experiences heat losses proportional to the new temperature. The dependence of the rate of heat loss from the steam pipe on the ambient air temperature is not nearly as dramatic as that of the building heating load. Since the elevated temperature of the steam pipe results in a large temperature difference between itself and the environment, the changes in this temperature difference due to changes of the environmental temperature are relatively small. For example, during the 1987/88 heating season the largest temperature difference between the mean ambient air temperature and the steam pipe occurred on 25 December when the temperature difference was 177.20°C (170 to -7.2) (319°F). By contrast this temperature difference was at its lowest value during the 1987/88 heating season on 27 October when it was 154.4°C (170 to 15.6) (278°F). Thus, this temperature difference is only 12.8% less at its minimum than when at its maximum. The rate of heat loss will vary by a somewhat lesser amount, since the thermal mass and thermal resistance of the concrete trench and surrounding soil will tend to dampen the effective temperature difference between the steam pipe and the environment. Hence, during this period when the space heating load would range from essentially zero to its maximum value, the heat

losses from the steam distribution system will undergo much less variation. For this reason we will assume that the heat losses from the steam pipe are constant over the heating season. This allows us to lump the steam use due to these heat losses with the steam use due to leaks.

The remaining steam load on the system, that due to the space heating requirements of the building, will vary substantially with the outdoor air temperature and thus the degree days accumulated. In fact, if our degree-day model were an exact representation, this load would disappear when the average outdoor air temperature for the day reached 18.3°C (65°F), the point at which no degree days would be accumulated for the day. In reality this is not true for several reasons, the primary one being inadequate control of the heating system in the buildings. Some of the building heating systems at Hawthorne AAP do not shut off completely when a specified indoor temperature level is achieved. This is a common problem in steam-heated buildings, resulting primarily from leaking valves that do not completely close. Thus, some portion of the load due to space heating at the buildings is residual after degree days are no longer being accumulated. This must be lumped with the "fixed" portion of the load on the system, resulting from steam leaks and heat losses from the steam distribution piping.

A linear function has been regressed onto the data of Figure 2 as shown. The slope of the regressed line is 0.0445 kg/s-°C-day (0.0545 lbm/s-°F-day) and the intercept is 0.663 kg/s (1.46 lbm/s). Based on the discussion presented above, the intercept would represent the sum of the loads due to steam leaks, heat losses from the steam piping, and residual heating of the building due to inadequate building control systems. The slope of the regressed line would represent the rate of increase of steam use as a function of increasing degree days. One measure of the efficiency of the distribution system is the ratio of the useful heat delivered to the total heating energy that leaves the plant. We can find the useful heat delivered using the slope of the regressed line from above. To do so we multiply the slope value from the regressed function by the length of a day and then in turn multiply the resulting value by the total number of degree days for the heating season. For the period of the 1987/88 heating season under study, the total accumulation of the weighted average degree days was 2026.5°C-days (3647.7°F-days). Thus, the total useful steam delivered was 7,791,000 kg (17,176,000 lbm). The total steam delivered will include, in addition to this useful steam, that which was con-

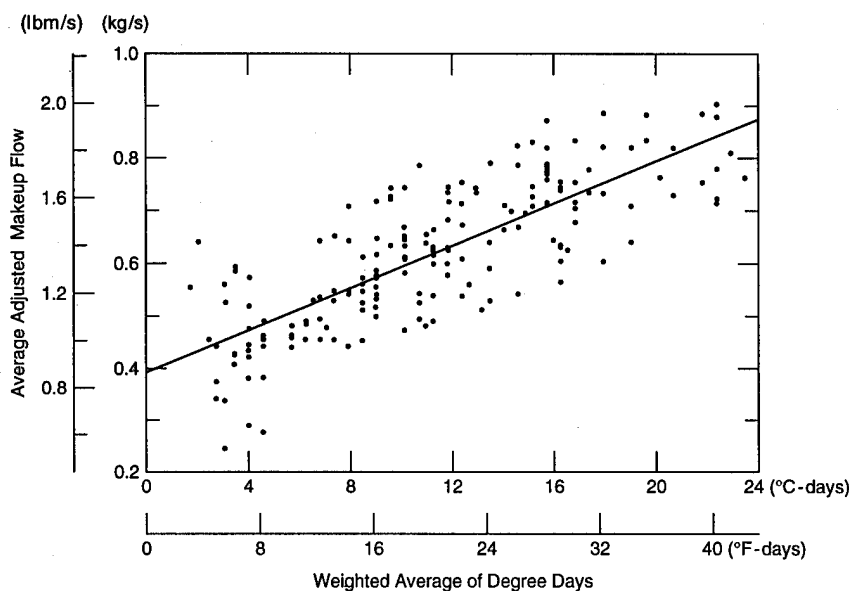

Figure 3. Adjusted average makeup flow rate as a function of degree days.

sumed due to heat losses and leaks as well as that unnecessarily used for building heating due to inadequate control. This remaining quantity is found by multiplying the intercept of the regressed line by the length of the period of the heating season under study (181 days), the result being 10,368,000 kg (22,832,000 lbm). Thus the total steam supplied was 18,159,000 kg (40,008,000 lbm). The distribution efficiency, that is the useful steam delivered divided by the total steam leaving the plant, is 42.9%.

The amount of water which must be added to the system to account for that lost is called the makeup. The amount of makeup water is another important measure of the efficiency of a heat distribution system. Figure 3 shows the average makeup water flow rate as a function of the weighted average degree days accumulated for each of the 181 days in the study period. This makeup water flow rate has been adjusted to be more representative of that due to losses in the distribution system and terminal equipment by subtracting the flow rate of water used in boiler blowdowns. Boiler blowdown is the term used to describe the periodic discharge of water from the bottom of the boiler. This water is discharged because it becomes high in contaminants as the pure water is boiled off.

Mass losses in the distribution system and terminal equipment occur in the following areas:

1. Steam leaks from the steam supply piping.
2. Steam and condensate leaks at the heat consumer's terminal equipment.

3. Condensate discarded at the consumers due to lack of a condensate return system.
4. Condensate leaks from the condensate return system.

The first two sources of leaks listed, those in the steam supply line and the consumer's equipment, will be primarily functions of pressure and thus fairly independent of heating load. To some extent this is also true of the leaks from the condensate return system. This system operates by gravity in most places. The condensate return piping is in poor condition in many places, however, and larger flow rates can result in slightly higher pressures or more completely filled pipes in cases where the pipes are not always flowing full. Thus, higher rates of leakage could accompany the increased flow resulting from higher heating loads. The remaining source of condensate loss, discarding at the consumer, will be highly dependent on heat load. With the exception of the portion of the heat load that results from excessive building heating due to inadequate control, all of the condensate loss from this source will be proportional to the load. A linear function has been regressed onto the data of Figure 3. The intercept of this linear function is 0.390 kg/s (0.860 lbm/s) and its slope is 0.020 kg/s-°C-day (0.0247 lbm/s-°F-day). In this case it is more difficult to determine what sources are responsible for the "fixed" losses represented by the intercept portion of the regressed function and what sources are responsible for the "variable" losses represented by the slope of the

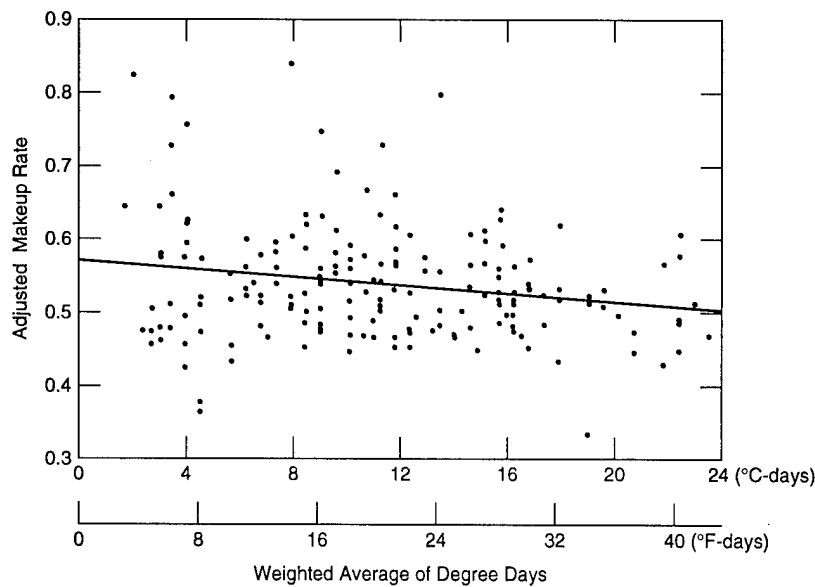

Figure 4. Adjusted makeup rate as a function of degree days.

regressed function. It is fairly certain, however, that most of the variable portion must be due to the condensate return system or lack thereof. Since leaks in the steam supply piping and terminal equipment were not prevalent during site visits, most of the fixed portion of the leakage can also be assumed to be in the form of condensate. Since the condensate has a much lower enthalpy than the steam, on a unit mass basis, the condensate leaks are of much less consequence than steam leaks would be. If we assume that all the mass loss is in the form of condensate, the equivalent energy loss would be the difference between the enthalpy of the condensate and that of the makeup water multiplied by the total mass loss from the system over the study period. From the regression equation the total mass loss is found to be 9,601,000 kg (21,234,000 lbm) and the enthalpy difference is 255.6 KJ/kg (109.9 Btu/lbm), so that the total equivalent energy loss from this mass leakage is 2,450 GJ (2,334 MBtu) for the study period. If 10% of the mass loss were to be in the form of steam the equivalent energy loss would be nearly double at 4,820 GJ (4,588 MBtu).

The most common measure of distribution system leakage is the makeup rate, as discussed earlier. We have adjusted the makeup rate by subtracting the makeup flow required for boiler blowdown. This yields a more representative picture of the mass losses in the distribution system and terminal equipment. Figure 4 shows the adjusted makeup rate as a function of the weighted average degree days accumulated for each day of the study period. A linear

function has also been regressed onto these data. The r^2 for this regressed function is only 3.7%, however, so it cannot be considered statistically significant. The average of all the adjusted makeup rate data for the entire study period is 54%.

Conclusions regarding the Hawthorne AAP steam system

With limited data we have constructed some estimates of the thermal and mass losses from the Hawthorne AAP steam heat distribution system. These estimates indicate that losses from the system are very high. Our estimates indicate that only 43% of the steam leaving the plant is ultimately used for required space heating. The remainder (57%) is consumed in steam and condensate leaks, heat losses, and unnecessary overheating of buildings due to poor control. Most of these losses would be drastically reduced if a low temperature hot water heat distribution system were retrofitted to Hawthorne AAP. For example, Werner (1984) reports the heat losses from six Swedish low temperature hot water heating systems as ranging from 4.9% to 7.7% of the total heat production, with the average being 6.6%. It is also clear from Werner's (1984) data that the heating load drops to 10%, or less, of its maximum value during times of low load. Since this includes domestic tap water heating as well as distribution system heat losses, it is apparent that control of the building heating systems on a low temperature hot water system must be much more effective than on the Hawthorne AAP steam system. Based on the

experiences of the European systems (Werner 1984) it would seem reasonable to assume that the distribution efficiency of a low temperature water system might be of the order of 90% or more. This compares very favorably with our estimate of 43% for Hawthorne AAP.

Our estimates of mass losses from the Hawthorne AAP steam system are also cause for concern. On the average only 46% of the steam that leaves the plant is returned as condensate. Relatively high mass losses are commonplace in steam systems, primarily due to the problems associated with condensate collection and return. Makeup rates of 10 to 20% are normally considered good for steam systems. The Hawthorne system, however, has a makeup rate of 54%. Some steam systems are even worse than the Hawthorne AAP system. For example, the author was recently told of a 10-year-old steam system designed to return all of the condensate that was in fact returning only 10% of the condensate, i.e., a makeup rate of 90%. For a low temperature hot water system, the makeup rate would most likely be 5% or less. Here again a significant improvement can be made by switching to low temperature hot water.

Economics is usually the driving force behind a decision to retrofit existing steam and high temperature hot water systems to low temperature hot water operation. If we make the conservative assumption that there are no leaks in the Hawthorne steam supply line, we can make some estimates of the cost savings that could be obtained from converting to low temperature hot water operation. The fuel use for a low temperature system would drop to about 48% (43%/90%) of the existing value just due to excess steam now used due to heat losses for the distribution system, condensate leaks, and overheating of the building due to inadequate control. If we assume a value of \$10/GJ for energy costs, the total fuel consumption for the 181-day study period of 1,445,250 L (381,836 gal) would be reduced to 693,720 L (183,281 gal), representing a savings of about \$292,000.

In addition, the need to heat makeup water would be reduced by a significant amount, resulting in additional savings. If we include the energy loss due to mass leakage based on our previous calculations, we can estimate these additional savings. In this case if we assume that 10% of the mass lost is in the form of steam and the remainder is condensate then the total savings would be increased to \$322,880 for the study period.

The study period did not represent an entire heating season, only that portion of the season when boiler plant operation was continuous. Savings in an

entire year would be somewhat greater. Additional savings might also be possible by switching the buildings from heating domestic hot water with electricity to using the low temperature system for that purpose. This would require that the system be left in operation over the entire year, rather than being shut down for the summer as is done now. With the greatly reduced rate of heat loss from the low temperature hot water system, the cost of heat losses from the system during the summer months might not make this economically prohibitive, as it would be with the existing steam system.

To determine if it would be economically feasible to convert the steam system at Hawthorne AAP to a low temperature hot water system, CRREL contracted with the Sacramento District of the US Army Corps of Engineers to prepare a detailed cost estimate and preliminary design for the conversion. The design work consisted of a concept design for the entire system and a detailed design for conversion of three of the buildings. The estimated cost of the conversion contract was approximately \$5.8 million and with contingencies, supervision and inspection, etc., approximately \$6.8 million was estimated for the entire project. Of this cost, the building conversion costs were about \$2.1 million, with almost half of that cost being associated with asbestos abatement due to pipe insulation containing asbestos. The distribution system cost was approximately \$2.6 million. A temporary boiler required during the plant conversion was estimated to cost about \$0.6 million.

From the projected project costs and savings given above it was clear that this project was not economically viable on the basis of energy savings alone. This result could be entirely different if, due to other reasons such as health considerations or required replacement of equipment, some portion of the work was justifiable by other means. For example, assume that the distribution system has deteriorated to the point where it needs to be replaced regardless of whether the conversion to LTHW is considered. Thus the \$2.6 million cost for the distribution system would be subtracted from the \$5.8 million project total and the cost of the conversion would be lowered to about \$3.2 million plus contingencies, supervision and inspection, etc. Under this condition the project would most likely just meet the current Energy Conservation Investment Program (ECIP) criteria of 10-year payback. Another possibility might be if renovations of the buildings were being accomplished independently of a decision to convert to LTHW. In this case the economics are not quite as favorable,

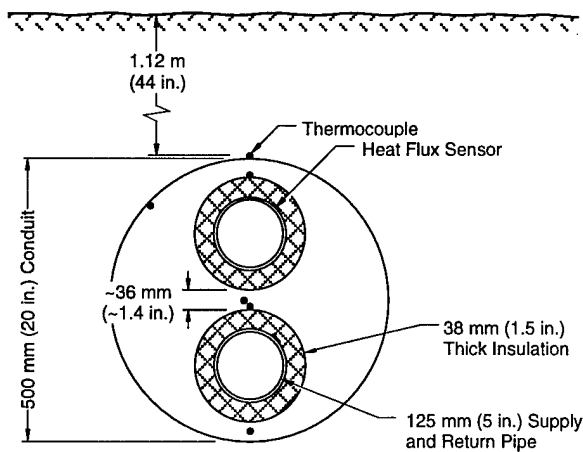

Figure 5. Construction details for the MTHW common conduit site.

but a detailed cost analysis and refinement of the LTHW design might still identify an economically viable project under ECIP criteria.

HEAT LOSS MEASUREMENTS

Over the past few years we have instrumented operating systems on Army facilities in order to make measurements of heat losses under realistic field conditions. Ft. Jackson, South Carolina, was selected as one site because a large replacement project was underway there on what would be classified as a medium-temperature hot water (MTHW) system consistent with the definitions given in ASHRAE (1992). Three types of heat distribution piping systems were instrumented.

In addition to the three sites at Ft. Jackson, two sites were instrumented on a low-temperature hot water (LTHW) system at Ft. Irwin, California. The LTHW system was a new system built to serve a new barracks complex. The specifics of the construction of all of these systems are discussed below.

MTHW common conduit system

The common conduit system has both the supply and return piping in the same steel conduit (Fig. 5). This is a prefabricated system that conforms to the Federal Agency Criteria for a class A system. This type of system is designed and installed in accordance with Corps of Engineers Guide Specification (CEGS) 02695 (U.S. Army Corps of Engineers 1989).

The class A conduit system used at Ft. Jackson consists of schedule 40 steel supply and return pipes of approximately 125 mm (5-in. nominal pipe size

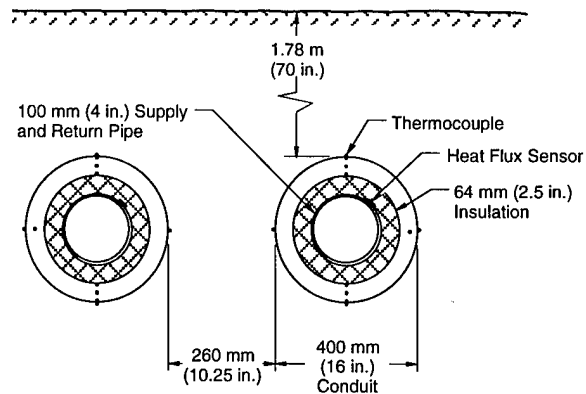

Figure 6. Construction details for the MTHW individual conduit site.

[NPS]). These pipes are insulated with a mineral wool insulation of 38 mm (1.5-in.) thickness. The insulated supply and return pipes are encased in a spiral wound steel conduit, which is approximately 3.2 mm (1/8 in.) thick. The supply and return pipes are positioned within the conduit with the supply pipe on top of the return pipe. The conduit has an outer diameter of approximately 500 mm (20 in.), thus allowing for an air space between the pipe insulation and the inside of the conduit.

MTHW individual conduit system

The individual conduit system (Fig. 6) employs the same construction features as the common conduit system described above. In this case the supply and return pipes are approximately 100-mm (4-in. NPS) Schedule 40 steel and each is encased in its own individual conduit of approximately 400-mm (16-in.) outer diameter. The insulation on the pipes is mineral wool and is 64 mm (2.5 in.) thick in each case.

MTHW shallow concrete trench system

The shallow concrete trench system (Fig. 7) consists of a cast-in-place concrete trench with cast-in-place concrete covers. The interior dimensions of the shallow concrete trench at the Ft. Jackson test site are 1 m (40 in.) in width and 550 mm (21.5 in.) in height. The trench walls are 140 mm (5.5 in.) thick and the trench covers are 150 mm (6 in.) thick, having a lip of about 25 mm (1 in.) at the outside edge so that the portion resting on the trench wall is about 125 mm (5 in.) thick. The supply and return piping is approximately 125-mm (5-in. NPS) Schedule 40 steel. Each pipe is insulated with 64 mm (2.5 in.) of mineral wool pipe insulation.

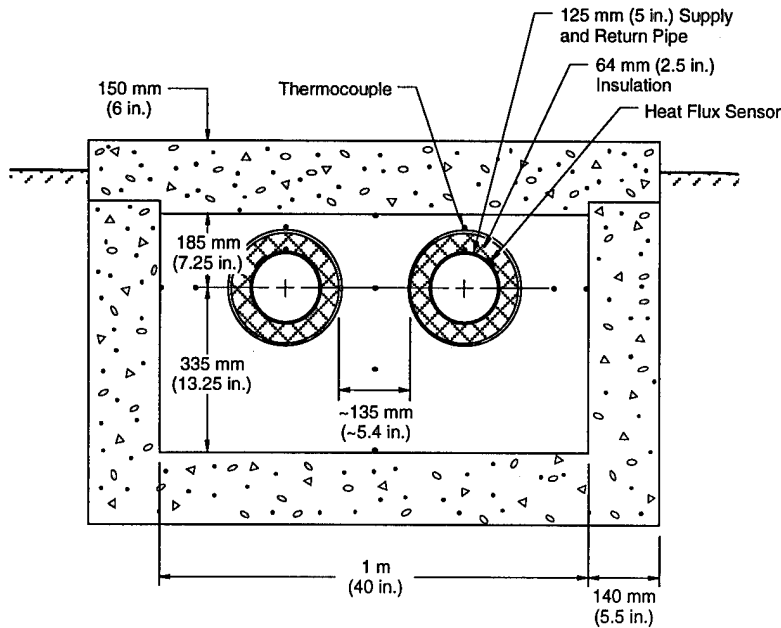

Figure 7. Construction details for the MTHW trench site.

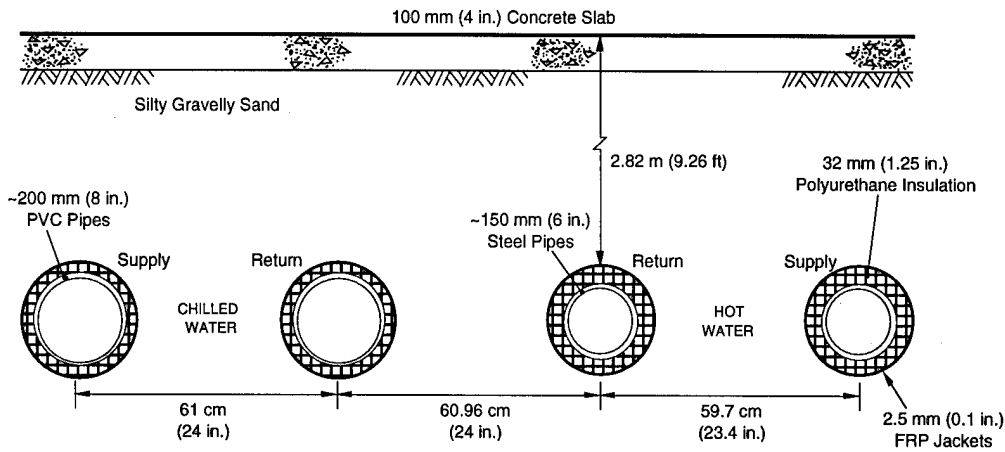

Figure 8. Construction details for the LTHW site 1.

LTHW preinsulated system, site 1

The pre-insulated piping system used at Ft. Irwin consists of schedule 40 steel pipes. At Ft. Irwin Site 1 the supply and return pipes are of approximately 150-mm diameter (6-in. NPS). These pipes are insulated with a polyurethane foam insulation of approximately 32 mm (1.25-in.) thickness. Each insulated pipe is encased in its own fiberglass-reinforced plastic (FRP) jacket, which is approximately 2.5 mm (0.10 in.) thick. The jacket has an outer diameter of approximately 240 mm (9.4 in.). The insulation was "foamed-in-place," thus allowing for no air space between the pipe insulation and inside of the jacket. Figure 8 shows the construction details of both of the LTHW sites.

LTHW preinsulated system, site 2

The pre-insulated piping system used at Ft. Irwin Site 2 is similar in construction to that used at Ft. Irwin Site 1, but is of a different size (Fig. 9). At Ft. Irwin Site 2 the supply and return pipes are approximately 75 mm in diameter (3-in. NPS). These pipes are insulated with a polyurethane foam insulation of approximately 32-mm (1.25-in.) thickness. Each insulated pipe is encased in its own fiberglass-reinforced plastic (FRP) jacket, which is approximately 2.5 mm (0.10 in.) thick. The jacket has an outer diameter of approximately 160 mm (6.25 in.). Again the insulation was "foamed-in-place" so that no air space exists between the pipe insulation and inside of the jacket.

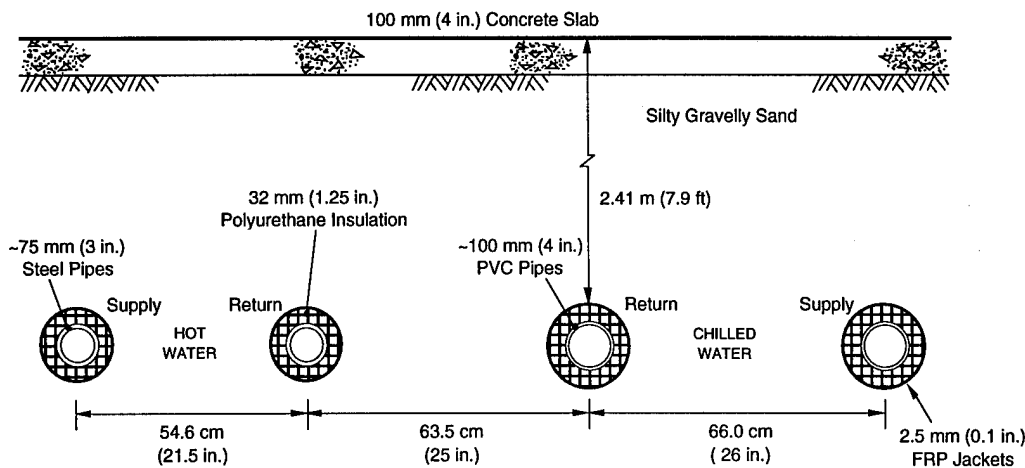

Figure 9. Construction details for the LTHW site 2.

Instrumentation, data logging and communication systems

The instrumentation consists primarily of type T copper-constantan thermocouples constructed from 20 AWG thermocouple extension wire. Detailed information on the location of the 167 thermocouples used on the MTHW sites at Ft. Jackson can be found in Phetteplace et al. (1991). A report currently in preparation will describe in detail the instrumentation of the Ft. Irwin LTHW sites. Heat flux sensors were used at all sites, but the results from these are inconclusive for reasons described in Phetteplace et al. (1991). On each of the systems instrumented, one site along the length of the system was selected. Each of the sites at Ft. Jackson was located at least 7.5 m (25 ft) from the closest manhole and was chosen as representative of the remainder of the system segment between manholes. On the LTHW system at Ft. Irwin, no manholes are used with all piping junctions buried directly in the ground. The sites at Ft. Irwin are at least 2.4 m (8 ft) from the closest junction or change in direction of the pipes.

Three microprocessor-controlled data loggers were used in this study. Each of these units was equipped with an RS-232 interface and modem so that we could transfer the data from the field sites at Ft. Jackson and Ft. Irwin directly to our personal computer at CRREL for processing. Again, more details on the extent of the data collected at Ft. Jackson can be found in Phetteplace et al. (1991), and for Ft. Irwin will be described in a future report.

Data analysis

Several different procedures are used to calculate the heat losses from the data collected at the five test sites. Some of these procedures are applicable to

more than one of the three system types while others are applicable for only one type of system. Each of these methods will be briefly described here and the systems for which each is applicable will be given. More detail on the actual methods used is included in Phetteplace et al. (1991). Worked examples of heat transfer calculations for these types of systems may be found in Phetteplace and Meyer (1990).

Insulation method

This method is applicable to all system types. With the observed temperatures on the inside and outside of the pipe insulation, the heat flow through the insulation can be easily calculated using the standard formulas for a concentric cylindrical cross section and the thermal conductivity of the insulation. In using this method on the MTHW systems, we assume that these temperatures are reasonably uniform around the circumference of the insulation. For the individual conduit system, this assumption is supported by the data of Lunardini (1989). Air temperature measurements within the concrete trench and common conduit systems in this study also support this assumption. For the LTHW system at Ft. Irwin, temperatures are measured at four equally spaced points around the perimeter of the piping system. These temperatures are then averaged and subsequently used to find the heat flow. Because of the difficulty of placing thermocouples between the jacket and insulation of the LTHW system, temperatures are measured on the outside of the jacket rather than at the outside of the insulation at these sites. An appropriate thermal resistance for the jacket has been added to the insulation thermal resistance in these cases.

Table 2. Averages of some calculated and measured values for the study sites.

Site	Supply temp. °C (°F)	Return temp. °C (°F)	Soil temp. @ pipe depth °C (°F)	Jacket or conduit temp supply/return °C (°F)	Heat loss by insulation method			Heat loss by soil method			Heat loss by CEGS method			
					Supply W/m (Btu/hr-ft)	Return W/m (Btu/hr-ft)	Total W/m (Btu/hr-ft)	Supply W/m (Btu/hr-ft)	Return W/m (Btu/hr-ft)	Total W/m (Btu/hr-ft)	Supply W/m (Btu/hr-ft)	Return W/m (Btu/hr-ft)	Total W/m (Btu/hr-ft)	
MTHW Trench	163.6 (326.4)	107.8 (226.0)	—	46.7/40.9 (116.0/105.6)	52.1 (54.2)	28.4 (29.6)	80.5 (83.8)	—	—	—	—	—	—	—
MTHW Common Conduit	164.8 (328.7)	120.8 (249.4)	17.4 (63.3)	54.1 (129.4)	63.3 (65.9)	40.7 (42.4)	104.0 (108.3)	—	—	104.9 (109.2)	74.6 (77.6)	42.8 (44.5)	117.4 (122.1)	—
MTHW Individual Conduit	165.3 (329.6)	111.6 (232.8)	14.1 (57.3)	28.7/28.1 (83.6/82.5)	48.5 (50.5)	28.8 (30.0)	77.3 (80.5)	—	—	—	46.0 (47.9)	25.9 (27.0)	71.9 (74.9)	—
LTHW Site 1	85.5 (185.9)	81.2 (178.2)	25.5 (77.9)	43.6/42.4 (110.5/108.3)	18.7 (19.5)	17.3 (18.0)	36.0 (37.5)	20.8 (21.6)	18.9 (19.7)	39.7 (41.3)	—	—	—	—
LTHW Site 2	83.5 (182.3)	80.3 (176.6)	25.6 (78.0)	37.6/37.1 (99.7/98.7)	12.3 (12.8)	11.6 (12.1)	23.9 (24.9)	13.2 (13.7)	12.3 (12.8)	25.5 (26.5)	—	—	—	—

Soil method, one pipe or conduit

This method is applicable only to the common conduit type of system. For the soil thermal resistance we use the formula for an isothermal cylinder buried in a semi-infinite medium having an isothermal surface (Holman 1972). The temperature of the cylinder and its radius are taken as those of the outside of the conduit. However, the isothermal soil surface temperature is not used as prescribed by this formula. Instead, the temperature of the soil at the depth of the pipe is used for reasons described below.

Soil temperatures vary with depth due primarily to changes in the air temperature. The thermal properties of the soil damp the amplitude of the temperature fluctuations at the surface and also cause a time delay for a temperature disturbance at the surface to reach the soil at some depth below. To accurately model the variations in heat transfer rate from a buried heat distribution system due to temperature variations at the surface requires a transient solution to the problem. Unfortunately, no closed-form transient solution is available for the case of a buried pipe. Numerical methods can be used to find very good approximate solutions to such problems, but they require much more effort than the closed form steady-state solutions. To account for the transient nature of the problem an approximation can be made by using the undisturbed soil temperature at burial depth instead of the ground surface temperature in the steady-state solution for a buried pipe (Janson 1963). We have made this substitution in the calculations for the results presented here, including those made with the other methods described below where soil surface temperature is also required.

Method for two buried pipes in individual conduits

This method is a combination of the two methods outlined above, but it also accounts for the thermal resistance of the air space and the interaction of the two conduits. For the MTHW results presented here, the method given by U.S. Army Corps of Engineers (1989), referred to as the CEGS-02695 method, has been used. This method uses steady-state conductances for the pipe, insulation, and soil. The heat transfer across the air space between outer surface of the insulation and the conduit is approximated as described below.

The actual heat transfer processes within the air space are far too complicated to warrant a complete treatment for the purpose of determining the heat losses from such systems. As an approximation, an effective heat transfer coefficient of $17 \text{ W/m}^2\text{-}^\circ\text{C}$

($3 \text{ Btu/hr-ft}^2\text{-}^\circ\text{F}$) has been assumed in the calculational procedure outlined by U.S. Army Corps of Engineers (1989). This heat transfer coefficient is based on the outer surface area of the insulation. The validity of this assumption, based on some results from this study, is discussed in Phetteplace (1991b).

Method for two pipes buried in a common conduit

This method is applicable only to the case where both the supply and return pipes are in a common conduit. Here the same assumption as in the section above is made regarding heat transfer within the air space. The equations used are again those prescribed by U.S. Army Corps of Engineers (1989) and are referred to as the CEGS-02695 method here.

Soil method for two direct buried pipes

For the LTHW sites, the soil method uses the coupled two-pipe resistance formulation presented by Phetteplace and Meyer (1990). The same assumption made above regarding soil temperatures has again been made here. The thermal properties of the soil were estimated from published data (Kersten 1949) using measured soil moisture and classification.

Results of heat loss measurements

Most of the results will be presented in graphical form in order to present a large amount of information within a reasonable space. Table 2 provides a summary of some of the more important measured parameters and calculated results. In the graphical data presented in Figures 10-14, the sharp fluctuations sometimes observed usually result from short-term transients in the supply and return temperatures. Such transients can result from a number of causes such as the startup or shutdown of pumps, boilers, or building equipment.

MTHW trench site

The average temperature of the supply pipe was 163.6°C (326.4°F) and for the return pipe 107.8°C (226.0°F). The average air temperature within the trench was 37.2°C (99.0°F). This temperature is the average of four air temperatures measured within the trench.

During the study period the average heat loss from the trench system was 80.5 W/m (83.8 Btu/hr-ft). This value was calculated using the "insulation method" described earlier, the only method used for the trench system. Figure 10 shows the heat loss from the shallow trench for the entire study period.

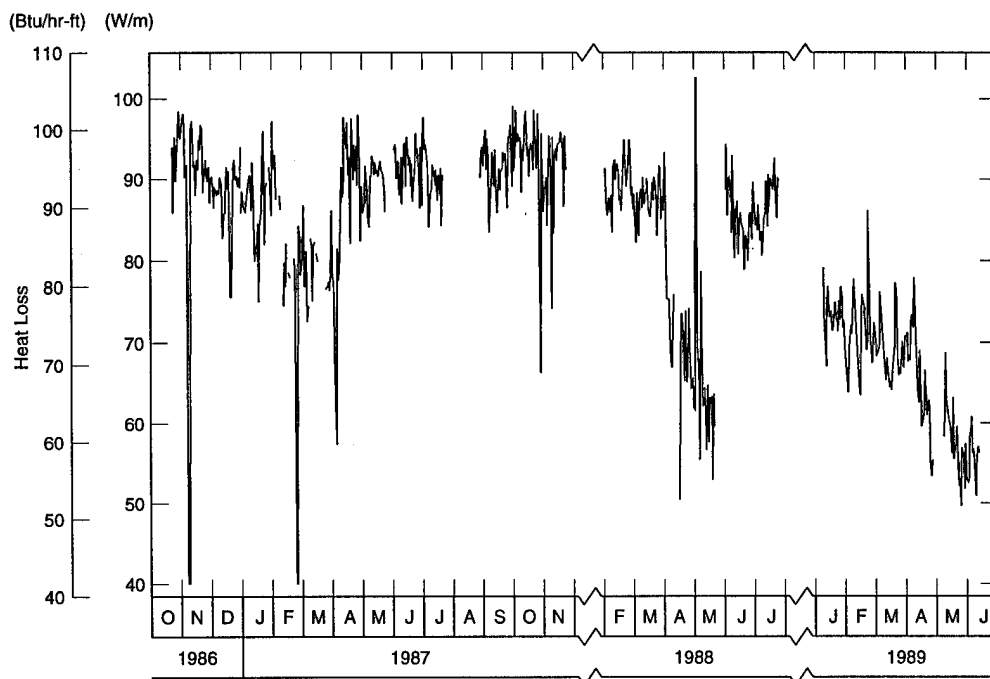

Figure 10. Heat losses for the MTHW trench site.

The reduction in heat losses during 1988 and 1989 over the previous years is attributable to the reduced return temperature during that time period. The cause of this temperature reduction is not known. This is a fairly significant reduction and provides a clear example of the benefits of keeping the temperature differential between supply and return as large as possible, thus resulting in lower return temperature. Not only will heat losses be reduced by lower return temperatures, but pumping costs are also reduced since less mass will need to be circulated. Of course, this assumes that the thermal load is constant and that some method of reducing pumping power input, such as variable speed drives or multiple pumps, is available.

MTHW common conduit site

Figure 11 shows the heat loss from the MTHW common conduit site over the study period. The temperature of the supply at this site during the study period averaged 164.8°C (328.7°F) and the return averaged 120.8°C (249.4°F) for the same period of time. The supply temperature is somewhat higher (1.3°C , or 2.3°F) than the supply temperature observed at the trench site. The return temperature averaged about 130°C (23.4°F) higher at this site as well. This would tend to make heat losses higher at this site if all else were equal, as of course is not the case. The temperature of the outer surface of the

conduit averaged 54.1°C (129.4°F), while the undisturbed ground temperature at approximately the same depth as the centerline of the conduit averaged 17.4°C (63.3°F). This illustrates the rather dramatic effect of the buried conduit on surrounding soil temperatures.

The heat losses for the common conduit system were calculated by three of the methods described earlier. The method referred to as the "soil method" uses the single buried pipe equation and the conduit outer surface temperature to calculate the heat flow. The thermal conductivity of the soil is taken as $1.08 \text{ W/m}\cdot^{\circ}\text{C}$ ($7.5 \text{ Btu}\cdot\text{in.}/\text{hr}\cdot\text{ft}^2\cdot^{\circ}\text{F}$) in this and the CEGS-02695 method, which is believed to be a realistic average value based on the observed soil type and moisture content (Phetteplace et al. 1991) and published data (Kersten 1949). Because of the inhomogeneous nature of soil and the difficulty in making thermal measurements on soils, this value is considered to be accurate only to within 25%.

The average of the values computed by the three methods is 108.8 W/m ($113.2 \text{ Btu/hr}\cdot\text{ft}$). The highest of the methods (CEGS-02695) was approximately 7.6% greater than the average value and the lowest (insulation method) was 4.3% below the average. Considering the difficulty involved in making thermal measurements of this nature, we believe this agreement is very good. This is particularly true when one considers that the CEGS-02695 method

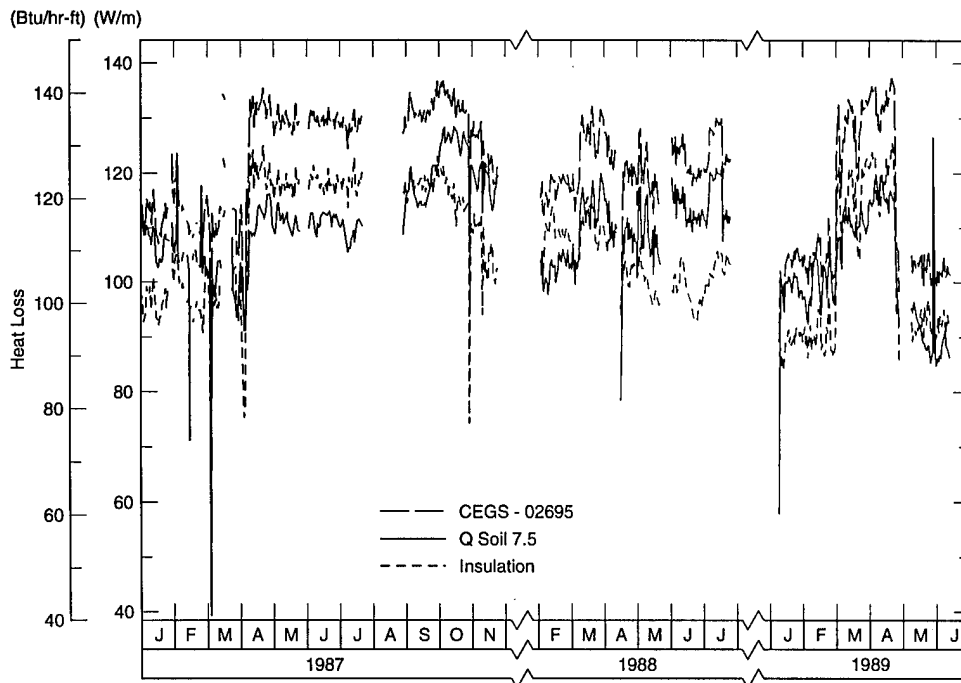

Figure 11. Heat losses from the MTHW common conduit site.

may have conservative assumptions (in that they would under-predict the actual thermal resistance) regarding the heat transfer across the air space, as discussed in Phetteplace (1991b).

The heat losses for the entire study period for the common conduit site are shown in Figure 11. Note that during the early spring (around March), for each of the three years that we have data during this time period, the results from the insulation method increase to a value greater than those for the soil method. Some time during the fall (about mid-September for 1987, the only year for which we have data during this time period) the trend is reversed. The soil moisture content offers one possible explanation for this. Soil samples taken for this study (Phetteplace et al. 1991) indicate that the soil moisture content is higher during the spring and summer than in the winter. One plausible explanation for this would be that it takes a considerable length of time for the winter precipitation to diffuse into the low-permeability soil found at Ft. Jackson. Subsequently the soil dries out slowly during the summer reaching its lowest moisture content in the fall and winter.

If the moisture content of the soil around the conduit, particularly that between the conduit and the ground surface, increases during the spring and summer months, then the thermal conductivity of the soil will increase during that time period as well.

This will reduce the thermal resistance of the soil in an absolute sense as well as relative to the other thermal resistances in the system. Presumably the other thermal resistances remain fairly constant year-round, notably the insulation thermal resistance which is much greater than the thermal resistance of the soil or any other thermal resistance in the system. Thus, the overall thermal resistance will be reduced by a much smaller relative amount than the soil thermal resistance. With the lower thermal resistance the temperature drop across the soil from the conduit casing to the ground surface will decrease relative to the other temperature drops in the system. However, we have assumed that the thermal conductivity of the soil is constant year-round in our soil method, and thus with the lower actual resistance and relative temperature drop measured we will underpredict the heat flow.

MTHW individual conduit site

At the individual conduit site, the temperature of the supply during the study period averaged 165.3°C (329.6°F) and the return averaged 111.6°C (232.8°F) for the same period of time. The temperature of the outer surface of the conduit averaged 28.7°C (83.6°F) for the supply and 28.1°C (82.5°F) for the return. The undisturbed ground temperature at approximately the same depth as the centerline of the conduit averaged 14.3°C (57.3°F). Here the average tem-

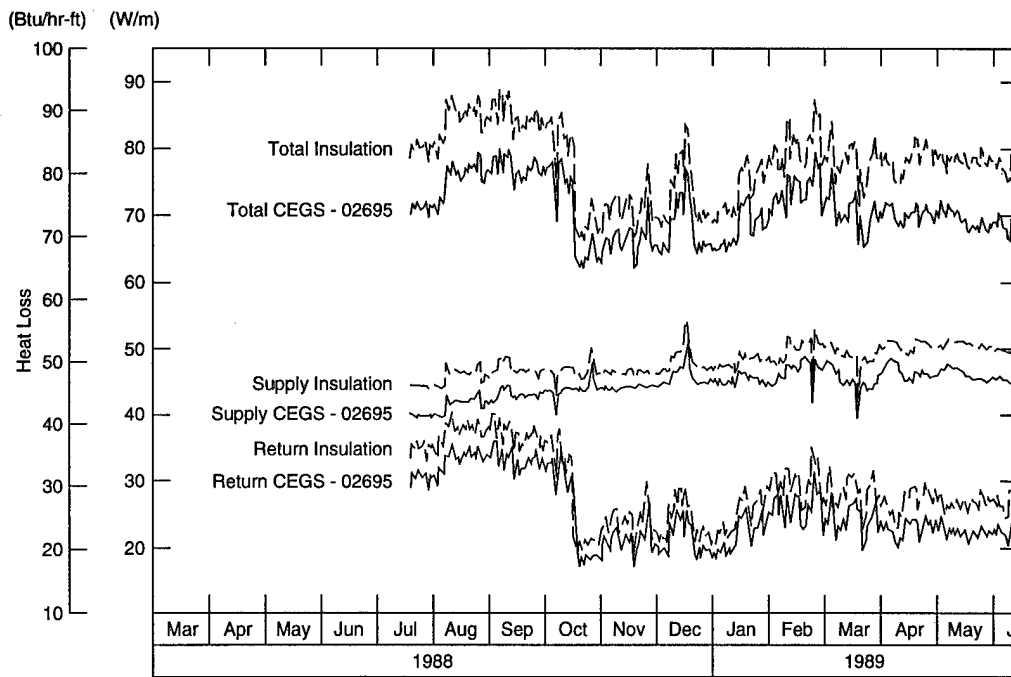

Figure 12. Heat losses from the MTHW individual conduit system.

perature difference between the outside of the conduit and the undisturbed soil temperature at the burial depth is only -3.4°C (25.8°F). This can be compared to a temperature difference of about 36.7°C (66°F) at the common conduit site. The primary reason for this much lower temperature difference at the individual conduit site is the increased insulation thickness at that site. Because the thermal resistance of the insulation is much larger at the individual conduit site, the thermal resistance of the soil becomes a much smaller fraction of the total, and thus the corresponding temperature drop across that resistance decreases.

The heat losses for the individual conduit system were calculated by the insulation and CEGS-02695 methods described earlier. As in the calculations for the common conduit site, the thermal conductivity of the soil was taken as $1.08 \text{ W/m}\cdot^{\circ}\text{C}$ ($7.5 \text{ Btu-in./hr}\cdot\text{ft}^2\cdot^{\circ}\text{F}$) for the CEGS-02695 method. The average of the heat loss values computed by the two methods is 74.7 W/m ($77.7 \text{ Btu/hr}\cdot\text{ft}$). The highest of the methods (Insulation Method) was approximately 7.5% greater than the lowest (CEGS-02695 Method). Again, considering the difficulty involved in making thermal measurements of this nature, we believe this agreement is very good. The heat losses for a

portion of the study period for the individual conduit site are shown in Figure 12.

LTHW preinsulated system, site 1

On the LTHW system at Site 1, the temperature of the supply during the study period averaged 85.5°C (185.9°F) and the return averaged 81.2°C (178.2°F) for the same period of time. The relatively small temperature difference between supply and return must be attributed to the mass flow rate being in excess of what is required. It is not known if this resulted from an error in design or from the substitution of a larger pump in the construction process. The temperature of the outer surface of the FRP jacket averaged 43.6°C (110.5°F) for the supply and 42.4°C (108.3°F) for the return. The undisturbed ground temperature at approximately the same depth as the centerline of the pipe averaged 25.5°C (77.9°F). Here the average temperature difference between the outside of the jacket and the undisturbed soil temperature at the burial depth is 17.5°C (31.5°F). This can be compared to a temperature difference of about 36.7°C (66°F) at the common conduit site and 14.3°C (25.8°F) at the individual conduit site. As with the individual conduit site, the primary reason for this much lower temperature

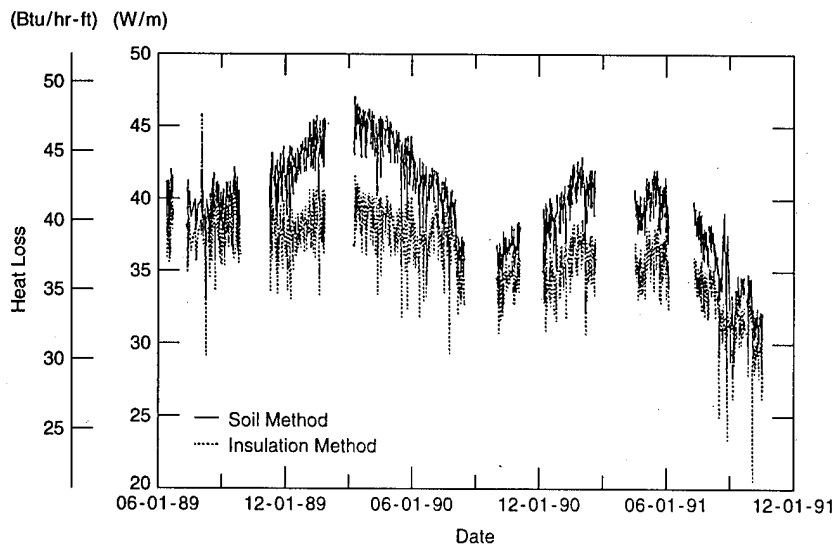

Figure 13. Heat losses from the LTHW site 1 system.

difference compared to the common conduit site is the increased insulation resistance at this site. Because the pipes at this site are buried very deep (3.0 m or 9.7 ft) this site has a relatively significant thermal resistance in the soil which results in significant temperature drops in the soil. Thus, the temperature drop between the jacket and the undisturbed soil at this site is slightly more than at the individual conduit site even though the heat losses are much lower.

The heat losses for the LTHW site 1 system were calculated by the insulation and soil methods described earlier. The thermal conductivity of the soil was taken as $1.46 \text{ W/m}\cdot\text{C}$ ($10 \text{ Btu}\cdot\text{in.}/\text{hr}\cdot\text{ft}^2\cdot\text{F}$) for the soil method. This value is based on published data (Kersten 1949) and measured soil moisture and classification. The average of the heat loss values computed by the two methods is 37.9 W/m ($39.4 \text{ Btu}/\text{hr}\cdot\text{ft}$). The highest of the methods (soil method) was approximately 10.1% greater than the lowest (insulation method). The heat losses for the LTHW system site 1 for the study period are shown in Figure 13.

LTHW preinsulated system, site 2

For the LTHW system at site 2, the temperature of the supply during the study period averaged 83.5C (182.3F) and the return averaged 80.1C (176.2F). The temperature of the outer surface of the

FRP jacket averaged 37.6C (99.7F) and 37.1C (98.7F) for the supply and return, respectively. The undisturbed ground temperature at approximately the same depth as the centerline of the pipe averaged 25.5C (78.0F). Here the average temperature difference between the outside of the jacket and the undisturbed soil temperature at the burial depth is 11.7C (21.2F), the lowest of any of the direct buried systems in this study. Despite the fact that this system is buried deep (2.5 m or 8.2 ft.), the relatively high level of insulation results in less significant temperature drops in the soil compared to the LTHW system site 1, where the same thickness of insulation is used on a pipe nearly twice as large in outer diameter. Thus, the temperature drop between the jacket and the undisturbed soil at this site is considerably less than for site 1 on the LTHW system.

As was done for site 1 on the LTHW system, heat losses from site 2 were calculated by the insulation and soil methods described earlier. Again, the thermal conductivity of the soil was taken as $1.46 \text{ W/m}\cdot\text{C}$ ($10 \text{ Btu}\cdot\text{in.}/\text{hr}\cdot\text{ft}^2\cdot\text{F}$) for the soil method. The average of the heat loss values computed by the two methods is 24.7 W/m ($25.7 \text{ Btu}/\text{hr}\cdot\text{ft}$). The highest of the methods (soil method) was approximately 6.4% greater than the lowest (insulation method). The heat losses from site 2 of the LTHW system over the course of the study period are shown in Figure 14.

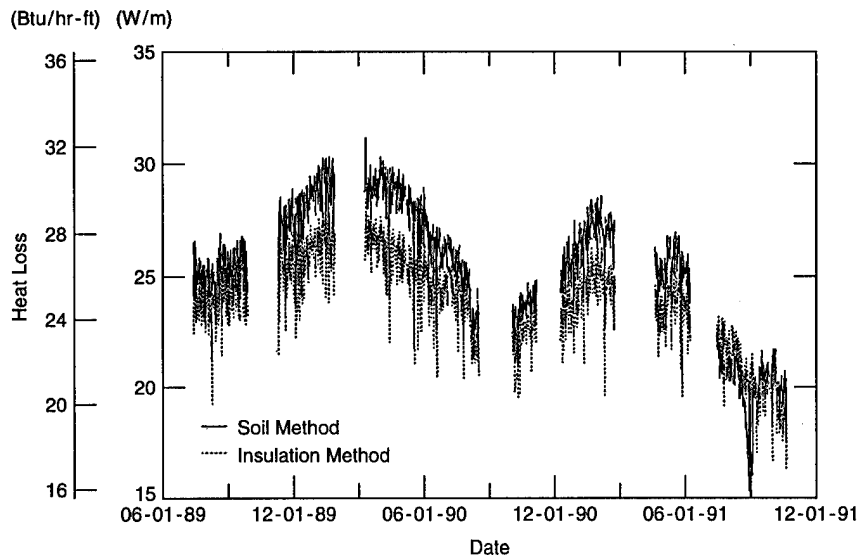

Figure 14. Heat losses from the LTHW site 2 system.

Conclusions drawn from heat loss measurements

The objective of our heat loss studies has been to achieve some insight into several aspects of thermal analysis of heat distribution systems. Of primary importance is the actual rate of heat losses from operating heat distribution systems. We have presented several years of data for five different sites on four types of heat distribution systems. In all but one case these heat losses have been measured under actual field conditions by more than one method. By making heat loss calculations using several different methods using independent measurements, we have established the validity of our techniques for systems similar to those studied. The methods used to make these measurements have proven to be very reliable and repeatable. In general, agreement between methods has been very good in terms of the magnitude of the heat losses as well as the trends over the yearly cycle.

The relative levels of heat losses found in our studies give rise to some significant conclusions regarding the cost of heat losses for the DoD and our ability to impact these costs. We can use these results to make an estimate of heat loss costs for DoD and also the savings which could be achieved by converting our high temperature water and steam systems over to low temperature hot water.

As an example, consider the reduction in heat losses possible with low temperature water as illustrated by some of the measurements taken on the Ft. Irwin system. At one of the Ft. Irwin sites

the supply and return piping is approximately 150 mm (6 in.) in diameter with approximately 32 mm (1.25 in.) of polyurethane foam insulation. The average value of the heat loss from this system using the two methods of measurement described earlier is about 37.5 W/m (39 Btu/hr-ft). For the medium temperature hot water system at Ft. Jackson, South Carolina, the common conduit site has approximately 125-mm (5-in.)-diameter supply and return piping with about 38 mm (1.5 in.) of mineral wool insulation. The heat losses of this system average 108.6 W/m (113 Btu/hr-ft) using the average of the three different methods of measurement described earlier. With proper design, the 150 mm (6-in.) low temperature piping is able to convey as much heat as the 125 mm (5-in.) medium temperature water piping. An example of the heat carrying capacity is given in Phetteplace (1992). Thus, the losses are reduced by a factor of nearly three. To put this in perspective, consider what this would do to the heat losses from the Army's 5600 km (3500 mi) of heat distribution piping (U.S. Army 1992). At 108.6 W/m (113 Btu/hr-ft) and \$9.48 per GJ (\$10 per million Btu) the annual cost of heat lost would be over \$182 million. For 37.5 W/m (39 Btu/hr-ft) and the same cost of heat the annual cost of heat losses would be about \$63 million. Thus, the Army could save nearly \$120 million per year from heat that is now lost to the environment. This assumes, of course, that all the existing systems have rates of heat loss similar to those of the Ft. Jackson system. Assuming that the size of the Ft. Jackson system is

representative, this is a conservative assumption, since the Ft. Jackson system is relatively new and is undoubtedly more thermally efficient than the Army's average system.

While these savings are significant, the cost of replacing the piping systems would be enormous. Current replacement cost for high temperature water and steam systems is approximately \$1000 per lineal meter (\$300 per lineal ft). If we assume that the cost of the LTHW systems is 50% of the cost of the high temperature water and steam systems they would replace, it would cost about \$2.8 billion to replace all the Army's 5600 km (3500 mi) of systems. Thus, the simple payback would be unacceptable, at about 23 years. But since these systems are continuously being replaced, many opportunities exist to convert to LTHW in those instances. Even when building conversion costs are considered, conversion to LTHW may be less costly than replacing in-kind from a capital cost standpoint alone. When the reduced operating costs of LTHW are considered, LTHW will have the lowest life cycle cost in many cases.

CONCLUSIONS

The objective of this report was to present information on the efficiency of heat distribution systems. Data were presented from several field studies conducted by CRREL on operating systems of Army bases. After studying this report the reader will conclude that low temperature hot water is a superior means of heat distribution. The primary advantages of low temperature water systems are listed below:

1. Capital costs are only about 50% of those for high temperature water and steam systems. This is a result of the much simpler system with fewer provisions for expansion and high pressures. In addition, the insulation and jacketing materials that can be used with LTHW not only perform better but they are less costly.
2. Heat losses are drastically reduced. As illustrated by the data given above, CRREL's measurements have shown the heat losses to be about 35% of those for a high temperature water system.
3. Leakage is usually much lower due to lower temperature and pressure. This is particularly true when compared to steam systems where problems with condensate return

usually result in significant mass losses. For example, the CRREL analysis of the Hawthorne AAP steam system described above has shown that about 50% of the mass is lost in distribution.

4. Maintenance is lower and the systems are safer as a result of lower temperatures and pressures. Frequently buildings can be connected directly to the central system without heat exchangers because of the lower temperatures and pressures.
5. Cogeneration of electricity is more favorable because the lower condensing temperature results in higher efficiency of the power generating cycle.
6. Lower density loads can be served economically. Because of the lower piping cost and simpler systems, it becomes economical to extend the distribution system into areas where the loads are smaller and farther apart. For this reason, even residential areas are served by low temperature systems in Europe.
7. Low temperature systems are more easily adaptable to many alternate sources of energy, such as solar, geothermal, and waste heat.

We hope that this report has helped provide evidence of the major advantages of low temperature hot water systems. Perhaps the strongest support for the concept comes from Europe where the vast majority of the systems are LTHW. There the much higher penetration of district heat as a space heating means is primarily due to the efficiency of the LTHW systems. If the DoD is to remain committed to district heating technology on its bases we must begin to convert existing high temperature water and steam systems to LTHW. If this is not done, it will become increasingly difficult to justify the use of district heating. This is true, even when all the inherent advantages of district heating from energy efficiency and environmental impact standpoints are considered, due to increased competition from alternate fuels, especially natural gas.

SELECTED BIBLIOGRAPHY

ASHRAE (1985) *ASHRAE Handbook, 1985 Fundamentals Volume, Chapter 15*. Atlanta, Georgia: American Society of Heating, Refrigerating, and Air-Conditioning Engineers.

- ASHRAE** (1992) *ASHRAE Handbook, 1992 HVAC Systems and Equipment Volume, Chapter 11*. Atlanta, Georgia: American Society of Heating, Refrigerating, and Air-Conditioning Engineers.
- ASME** (1977) *ASME Steam Tables, Third Edition*. New York: American Society of Mechanical Engineers.
- Holman, J.P.** (1972) *Heat Transfer, Third Edition*. New York: McGraw-Hill Book Co.
- Janson, L.** (1963) Water supply systems in frozen ground. In *Proceedings, 1st International Conference on Permafrost, 11-15 November, Lafayette, Indiana*. Washington, D.C.: National Academy of Sciences, National Research Council, Publication 1287.
- Kersten, M.S.** (1949) Laboratory research for the determination of the thermal properties of soils. Engineering Experiment Station, University of Minnesota.
- Lunardini, V.J.** (1989) Measurement of heat losses from a conduit type heat distribution system. USA Cold Regions Research and Engineering Laboratory, preliminary report (unpublished).
- Lunardini, V.J.** (1990) Measurement of heat losses from a conduit-type heat distribution system. *1990 Army Science Conference (ASC), 12-15 June 1990, Durham, North Carolina, Proceedings ASC*.
- Phetteplace, G.E.** (1990) Low temperature hot water heat distribution systems. USA Cold Regions Research and Engineering Laboratory, Facilities Engineering Applications Program (FEAP) Fact Sheet.
- Phetteplace, G.E.** (1991a) Efficiency analysis of a steam heat distribution system. In *Proceedings of the International Symposium on Fluids for District Heating, Copenhagen, Denmark, 10-11 April, 1991*, p. 199-213.
- Phetteplace, G.E.** (1991b) Measurement of heat losses from a buried heat distribution system. Presented at *1991 National Heat Transfer Conference, Minneapolis, Minnesota, American Society of Mechanical Engineers (ASME), HTD, vol. 172*, p. 47-54.
- Phetteplace, G.E.** (1992). Low temperature water for heat distribution systems. In *Proceedings of the U.S. Army Corps of Engineers Electrical/Mechanical Conference, Dallas, Texas, July 1992*, p. 139-145.
- Phetteplace, G.E. and N. Labbe** (1978) Heat distribution with low temperature hot water. USA Cold Regions Research and Engineering Laboratory, Technical Note (unpublished).
- Phetteplace, G.E. and V. Meyer** (1990) Piping for thermal distribution systems. USA Cold Regions Research and Engineering Laboratory, Internal Report 1059 (unpublished).
- Phetteplace, G.E., D. Carbee and M. Kryska** (1991) Field measurements of heat losses from three types of heat distribution systems. USA Cold Regions Research and Engineering Laboratory, Special Report 91-19.
- Phetteplace, G.E., W. Willey and M.A. Novick** (1981) Losses from the Fort Wainwright heat distribution system. USA Cold Regions Research and Engineering Laboratory, Special Report 81-14.
- Segan, E.G. and C. Chen** (1984) Investigation of tri-service heat distribution systems. U.S. Army Construction Engineering Research Laboratory, Champaign, Illinois, Technical Report M-347.
- U.S. Army** (1978) *Engineering Weather Data*. TM 5-785. Washington, D.C.: Department of the Army.
- U.S. Army** (1992) *Facilities Engineering and Housing Annual Summary of Operations, Volume III: Installations Performance, Fiscal Year 1992*. Office of the Assistant Chief of Engineers, U.S. Army Engineering and Housing Support Center.
- U.S. Army Corps of Engineers** (1989) Underground heat distribution systems (preapproved systems). CECS 02695, U.S. Army Corps of Engineers, Washington, D.C.
- Werner, S.E.** (1984) The heat load in district heating systems. Chalmers University of Technology, Goteborg, Sweden.

REPORT DOCUMENTATION PAGE

Form Approved
OMB No. 0704-0188

Public reporting burden for this collection of information is estimated to average 1 hour per response, including the time for reviewing instructions, searching existing data sources, gathering and maintaining the data needed, and completing and reviewing the collection of information. Send comments regarding this burden estimate or any other aspect of this collection of information, including suggestion for reducing this burden, to Washington Headquarters Services, Directorate for Information Operations and Reports, 1215 Jefferson Davis Highway, Suite 1204, Arlington, VA 22202-4302, and to the Office of Management and Budget, Paperwork Reduction Project (0704-0188), Washington, DC 20503.

1. AGENCY USE ONLY (Leave blank)		2. REPORT DATE September 1995		3. REPORT TYPE AND DATES COVERED	
4. TITLE AND SUBTITLE Efficiency of Steam and Hot Water Heat Distribution Systems				5. FUNDING NUMBERS PE: 6.27.84A PR: 4A762784AT42 TA: CO WU: M06	
6. AUTHORS Gary Phetteplace					
7. PERFORMING ORGANIZATION NAME(S) AND ADDRESS(ES) U.S. Army Cold Regions Research and Engineering Laboratory 72 Lyme Road Hanover, New Hampshire 03755-1290				8. PERFORMING ORGANIZATION REPORT NUMBER CRREL Report 95-18	
9. SPONSORING/MONITORING AGENCY NAME(S) AND ADDRESS(ES) Office of the Chief of Engineers Washington, D.C. 20314-1000				10. SPONSORING/MONITORING AGENCY REPORT NUMBER	
11. SUPPLEMENTARY NOTES					
12a. DISTRIBUTION/AVAILABILITY STATEMENT Approved for public release; distribution is unlimited. Available from NTIS, Springfield, Virginia 22161				12b. DISTRIBUTION CODE	
13. ABSTRACT (Maximum 200 words) This report will provide some general guidance on the selection of distribution medium (steam or hot water) and temperature for heat distribution systems. The report discusses the efficiency of both steam and hot water heat distribution systems in more detail. The results of several field studies using data from boiler plant logs and measured heat losses are given. For steam, an efficiency analysis for the steam heat distribution system at Hawthorne Army Ammunition Plant is summarized. This analysis is based on the limited data available from the boiler logs maintained at the central plant. From this information, along with energy and mass balances that are constructed from the central plant data, gross measures of efficiency are obtained. The results of the analysis show that only 43.5% of the steam input to the distribution system is used to meet the required space heating load. The results also indicate that on average only 46.2% of the steam that leaves the plant returns as condensate. By converting this steam distribution system to a low temperature hot water heat distribution system, savings would exceed \$292,000 for the 181-day study period, which represents a typical heating season. For hot water based systems this report describes two field projects underway at U.S. Army bases. At Fort Jackson, South Carolina, a medium-temperature hot water heat distribution system has been monitored. Three different types of system construction have been instrumented: pipes enclosed in a shallow concrete trench, steel conduit with supply and return pipes in common conduit, and separate steel conduits for supply and return pipes. At Ft. Irwin, California, a low-temperature hot water system has been monitored. Two sites have been instrumented on this direct buried system that consists of steel carrier pipes insulated with polyurethane foam protected by a fiberglass jacket. The data provide a clear illustration of the much lower heat losses from the low temperature water systems.					
14. SUBJECT TERMS Efficiency analysis Heat distribution systems Hot water heat distribution systems Steam heat distribution systems				15. NUMBER OF PAGES 32	
				16. PRICE CODE	
17. SECURITY CLASSIFICATION OF REPORT UNCLASSIFIED		18. SECURITY CLASSIFICATION OF THIS PAGE UNCLASSIFIED		19. SECURITY CLASSIFICATION OF ABSTRACT UNCLASSIFIED	
				20. LIMITATION OF ABSTRACT UL	