

ARMY RESEARCH LABORATORY



A Novel Permanent Magnet Electron Beam Guide

Herbert A. Leupold, Ernest Potenziani II,
Dennis P. Myers and David S. Furuno

ARL-TR-427

November 1995

DTIC QUALITY INSPECTED 3

19951227 015

APPROVED FOR PUBLIC RELEASE; DISTRIBUTION IS UNLIMITED.

NOTICES

Disclaimers

The findings in this report are not to be construed as an official Department of the Army position, unless so designated by other authorized documents.

The citation of trade names and names of manufacturers in this report is not to be construed as official Government endorsement or approval of commercial products or services referenced herein.

REPORT DOCUMENTATION PAGE

Form Approved
OMB NO. 0704-0188

Public reporting burden for this collection of information is estimated to average 1 hour per response, including the time for reviewing instructions, searching existing data sources, gathering and maintaining the data needed, and completing and reviewing the collection of information. Send comment regarding this burden estimate or any other aspect of this collection of information, including suggestions for reducing this burden, to Washington Headquarters Services, Directorate for Information Operations and Reports, 1215 Jefferson Davis Highway, Suite 1204, Arlington, VA 22202-4302, and to the Office of Management and Budget, Paperwork Reduction Project (0704-0188), Washington, DC 20503.

1. AGENCY USE ONLY (Leave blank)		2. REPORT DATE November 1995	3. REPORT TYPE AND DATES COVERED Technical Report	
4. TITLE AND SUBTITLE A NOVEL PERMANENT MAGNET ELECTRON BEAM GUIDE			5. FUNDING NUMBERS PR: 611102 PE: H94	
6. AUTHOR(S) Herbert A. Leupold, Ernest Potenziani II, Dennis P. Myers, and David S. Furono				
7. PERFORMING ORGANIZATION NAMES(S) AND ADDRESS(ES) US Army Research Laboratory (ARL) Physical Sciences Directorate (PSD) ATTN: AMSRL-PS-PC Fort Monmouth, NJ 07703-5601			8. PERFORMING ORGANIZATION REPORT NUMBER ARL-TR-427	
9. SPONSORING / MONITORING AGENCY NAME(S) AND ADDRESS(ES)			10. SPONSORING / MONITORING AGENCY REPORT NUMBER	
11. SUPPLEMENTARY NOTES				
12a. DISTRIBUTION / AVAILABILITY STATEMENT Approved for public release; distribution is unlimited.			12 b. DISTRIBUTION CODE	
13. ABSTRACT (Maximum 200 words) A unique, lightweight, clad permanent magnet structure which produces a constant, longitudinal magnetic field has been proposed previously. In this effort, a version of this structure appropriate for a conventional, linear beam electron tube was designed, constructed and evaluated. The permanent magnet system was designed to provide a 2.4 kOe axial guide field over a 23 cm distance. The design provides a volume of 3.5 cm diameter by 27 cm long for the microwave circuit, with radial penetrations for input rf, output rf and cooling. In order to minimize longitudinal flux at the position of the cathode, a shielded gun chamber is used. This chamber is clad with appropriate radially oriented magnets to prevent excessive flux leakage to the exterior and to insure field uniformity over the electron beam path. Figures depict the dependence of axial field magnitude on longitudinal position, and demonstrate excellent agreement between theory and measurement. The average field level measured is slightly higher than theoretical because of the switch to a higher remanence during construction. In addition, the field ripple near the collector end is due to penetrations in the magnet structure which were not modeled in the 2-D analyses.				
14. SUBJECT TERMS Permanent magnets; magnets; magnetic fields; electron tubes; solenoids			15. NUMBER OF PAGES 17	
			16. PRICE CODE	
17. SECURITY CLASSIFICATION OF REPORT Unclassified	18. SECURITY CLASSIFICATION OF THIS PAGE Unclassified	19. SECURITY CLASSIFICATION OF ABSTRACT Unclassified	20. LIMITATION OF ABSTRACT UL	

CONTENTS

	<u>Page</u>
Introduction and Summary	1
Electron Beam Focusing	1
Permanent Magnet Solenoid	2
Flux Supply	2
Flux Confinement or Cladding	3
Form of Solenoidal Structure	4
Actual Structure	4
Flux Patterns of Basic Field Source and that of the Required Structure	5
Beam Tester	7
Conclusions	8

Accession For	
NTIS CRA&I	<input checked="" type="checkbox"/>
DTIC TAB	<input type="checkbox"/>
Unannounced	<input type="checkbox"/>
Justification	
By	
Distribution /	
Availability Codes	
Dist	Avail and/or Special
A-1	

FIGURES

	<u>Page</u>
1. Permanent magnet solenoid.	2
2. Supply magnet, pole pieces and working space.	3
3. Cladding magnet construction.	3
4. Two permanent magnet solenoids: (A) without field-free chamber, (B) with field-free electron gun chamber on left end.	4
5. Side (A) and top (B) views of solenoid with access penetrations. (C) Flux plot of B.	5
6. (A) Axial and (B) transverse on-axis fields as a function of distance along Z axis.	6
7. The measured components of the field around the axis of rotation at the waveguide penetrations.	7
8. Sectional and assembled views of magnet structure: (A) empty magnet section, (B) magnet section with beam tester in place, and (C) closed, fully assembled structure.	9
9. Sectional details of magnet structure. (A) Partial cladding ring assembly jig, (B) section of assembled magnet.	10

INTRODUCTION AND SUMMARY

This work was done under a Cooperative Research and Development Agreement (CRDA) between the Army Research Laboratory and Martin Marietta Advanced Development Operations, and under a Martin Marietta Advanced Development Operations IR&D effort to provide an electron beam focusing device for CORSAM missile electronics.

A previously proposed, lightweight, clad permanent magnet structure which produces a constant, longitudinal magnetic field seemed appropriate for a conventional, linear beam electron tube which was then designed, constructed and evaluated.

The permanent magnet system was designed to provide a 2.4 kOe axial guide field over a 23 cm distance. The design provides a volume of 3.5 cm diameter by 27 cm long for the microwave circuit, with radial penetrations for input rf, output rf and cooling. In order to minimize longitudinal flux at the position of the cathode, a shielded gun chamber is used. This chamber is clad with appropriate radially oriented magnets to prevent excessive flux leakage to the exterior and to insure field uniformity over the electron beam path. The accompanying figure depicts the dependence of axial field magnitude on longitudinal position and demonstrates excellent agreement between theory (2-D Finite Element Analysis) and measurement. The average field level measured is slightly higher than theoretical because of the switch to a higher remanence material during construction. In addition, the field ripple near the collector end is due to penetrations present in the magnet structure which were not modeled in the 2-D analyses. The magnet structure has a mass of approximately 15 kg, which is about one third of that of the electromagnet that would otherwise be used. Also, the need for a high current electric power supply and cooling is eliminated. Details of the construction, the results of the three-dimensional computer analyses, axial and transverse field plots, and data on a 13 kV, 1.1 ampere beam tester are presented.

Acknowledgements

The authors would like to thank Dr. Allan H. Wegner, General Manager and Vice President of Martin Marietta Advanced Development Operations for his guidance and support throughout this project. In addition, the authors would like to thank Anil Nanji, Glenn K. Sadakane, Bill Ambrose, and the team at Magnet Sales for their hard work in the detailed design and fabrication of the magnet system.

The authors are also grateful for the technical assistance of Robert W. LeClair and George X. Ferguson of Martin Marietta Advanced Development Operations.

Electron Beam Focusing

To insure beam focusing in high average power microwave tubes, a solenoidal magnetic field is usually employed. The field is usually provided by an electric solenoid which allows minimum beam interception by the rf circuit and thereby minimum thermal loading. The disadvantage is in the weight of the solenoid windings, power supply, and cooling system. In order to produce a lightweight, high average power amplifier system, an alternative focusing structure is needed. A novel permanent magnet structure which produces a solenoidal field was chosen. A version of this magnet structure was designed and built to house a conventional linear beam tube. The structure was evaluated by Hall probe measurements of both axial and transverse fields, and through operation of a beam tester. Figure 1 shows a simpler version of the structure actually built.

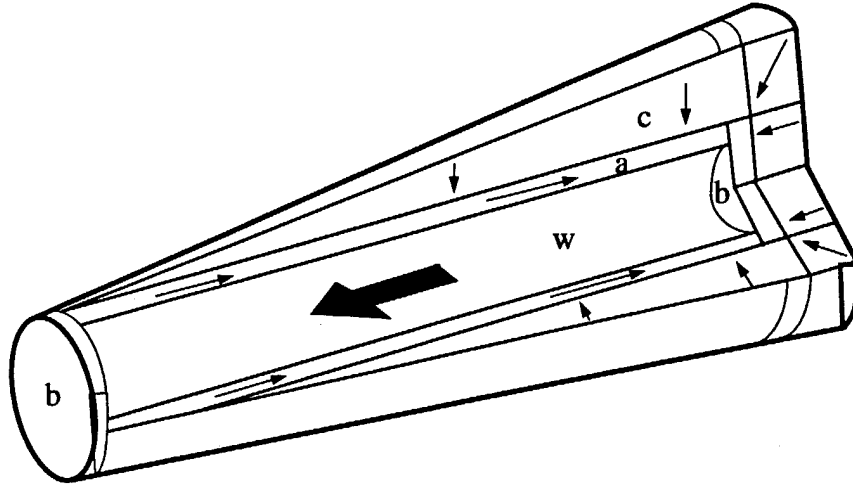

Figure 1. Permanent magnet solenoid.

Permanent Magnet Solenoid

The tube requires a uniform magnetic field $H_w = 2.0 - 2.5$ kOe confined to a cylindrical space, w . We assume that this has been attained and then deduce the form of the source necessary to attain it. The two functions of the source are assigned to separate structural components: (1) Flux supply and (2) Flux confinement (cladding).

In all of the pictures and calculations the following points should be noted:

- Magnetic fields are indicated by large, thick arrows
- Magnetization directions are indicated by small, thin arrows
- Gaussian magnetic units are used for design convenience
- μ_R denotes the slope of the demagnetization curve of the magnet used
- Only rigid (i.e., $\mu_R \approx 1$) permanent magnets are considered

Flux Supply

In Fig. 1, the cylindrical working space, w , is bounded by an axially magnetized permanent magnet shell (a). The shell is capped at its ends by iron discs (b) which guide all of the magnet's flux, Φ_M , into w , so that,

$$\Phi_M = \Phi_w \quad (1)$$

By Ampere's Law and the requirement of field uniformity:

$$H_M = H_w = B_w \quad (2)$$

These conditions afford computation of the supply magnet's cross sectional area, A_M , as shown in Fig. 2.

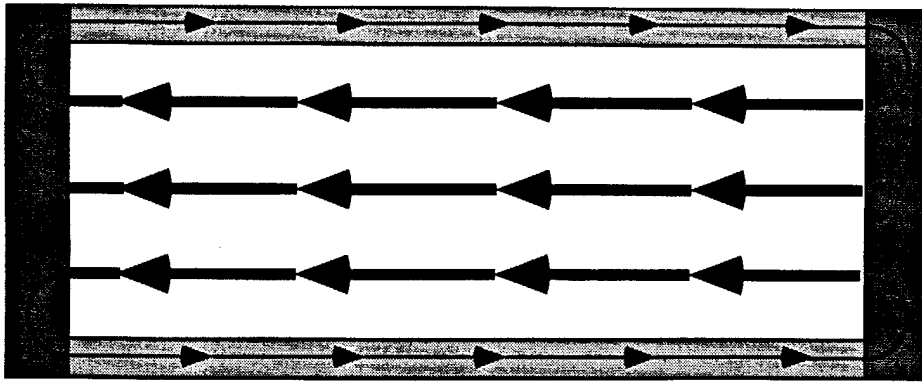

$$H_M = H_W$$

$$B_M A_M = H_W A_W$$

$$B_M = \mu_R H_M + B_R$$

$$A_M = A_W / \left(\mu_R - B_R / H_W \right)$$

Figure 2. Supply magnet, pole pieces and working space.

Flux Confinement or Cladding

Figure 2 illustrates the chain of reasoning used to arrive at the supply magnet dimensions. Figure 3 illustrates that used to obtain the cladding thickness. The steps in the cladding determination are summarized as follows:

- Flux is to be confined by a radially oriented magnet of unknown thickness $d(x)$
- By circuital form of Ampere's Law:

$$0 = \oint H \cdot dl = H_W x + H_C d + H_{ext}(BO) \quad (3)$$

where H_C is the radial field in the cladding magnet and H_{ext} is the field outside, which is zero by hypothesis, so that,

$$d = -H_W x / H_C \quad (4)$$

and the conical cladding c of Fig. 1 is formed.

- Where H_C is just the magnet coercivity since B_C by hypothesis is zero if no flux flows radially through the magnet to the outside.

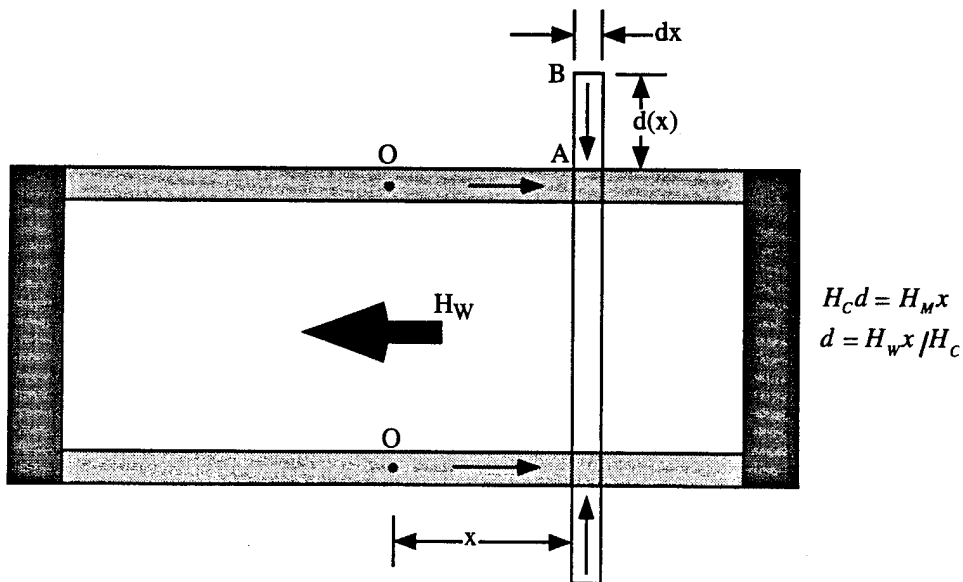

Figure 3. Cladding magnet construction

Form of Solenoidal Structure

To minimize mass, zero potential is taken to be midway between the iron pole pieces. Equation four then yields a double conical structure like the one in Fig. 4A. At the ends, outside the pole pieces, the cladding thickness is maximum and uniform since these are equipotential regions of maximum and minimum magnet potential. A flux-free chamber is added (left end, dark shading) to house a field-sensitive electron gun (Fig. 4B).

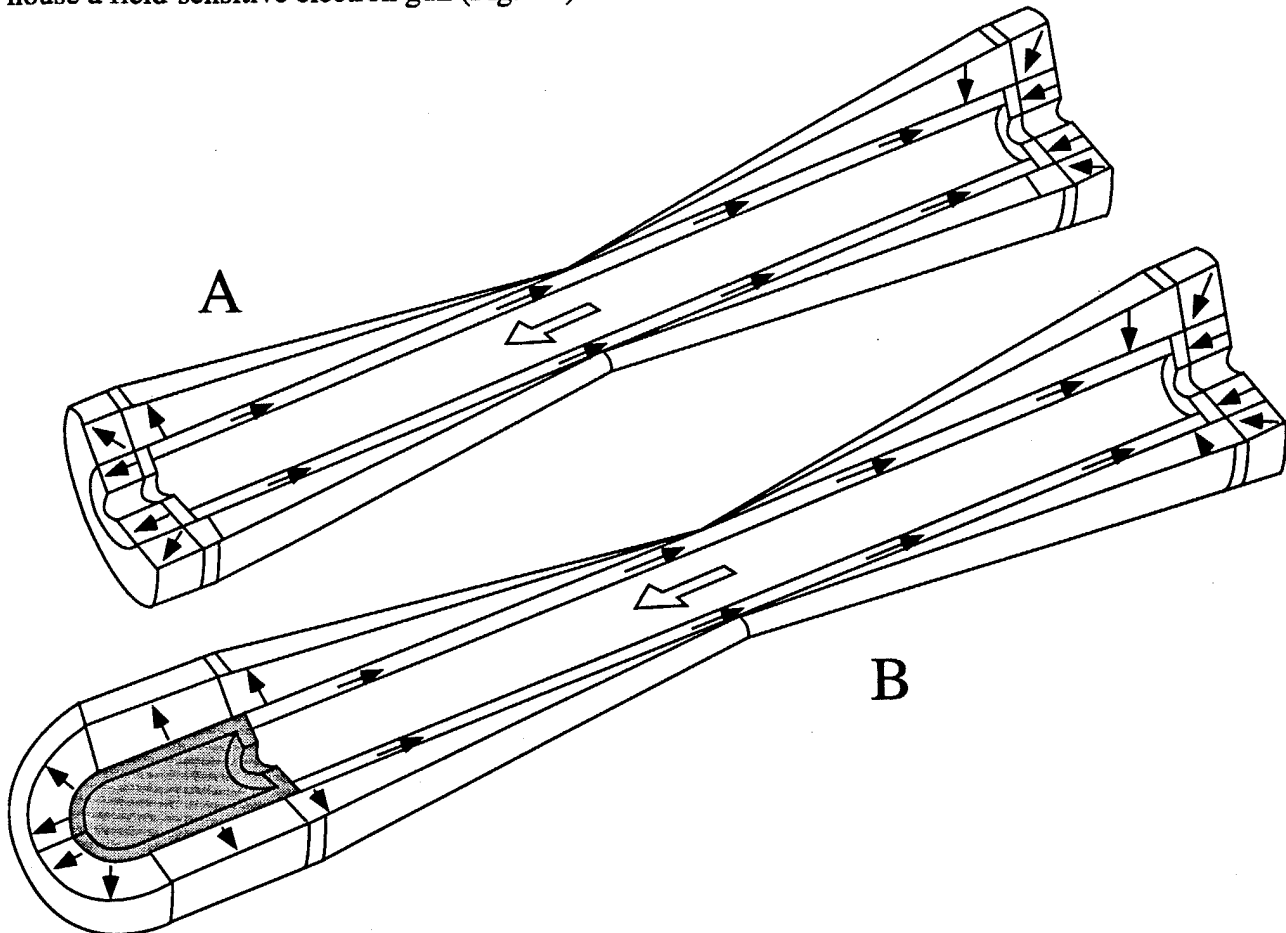

Figure 4. Two permanent magnet solenoids. (A) Without field-free chamber, (B) with field-free electron gun chamber on left end.

Actual Structure

The structure actually built differs from the ideal configuration B of Fig. 4 to afford access ports at both ends of the structure. The field distortion caused by them is reduced by dimensional, configurational and parametric changes (in magnetization strength) in the vicinity of the ports, especially the one on the electron-gun end. Also, the structure must be lengthened slightly so that the drop-off in field in the vicinity of the output end lies outside of the interaction region.

To accommodate the rf structure, penetrations were required in the magnetic material. A coaxial line was chosen for the rf input to minimize the penetration near the gun region. Coolant lines were brought out in the center of the structure where the effect is small due to the small amount of cladding material. The largest effect is at the rf output penetrations. Here two rectangular holes were placed 180 degrees apart for symmetry and the magnet structure was extended in length to compensate for the drop-off in field.

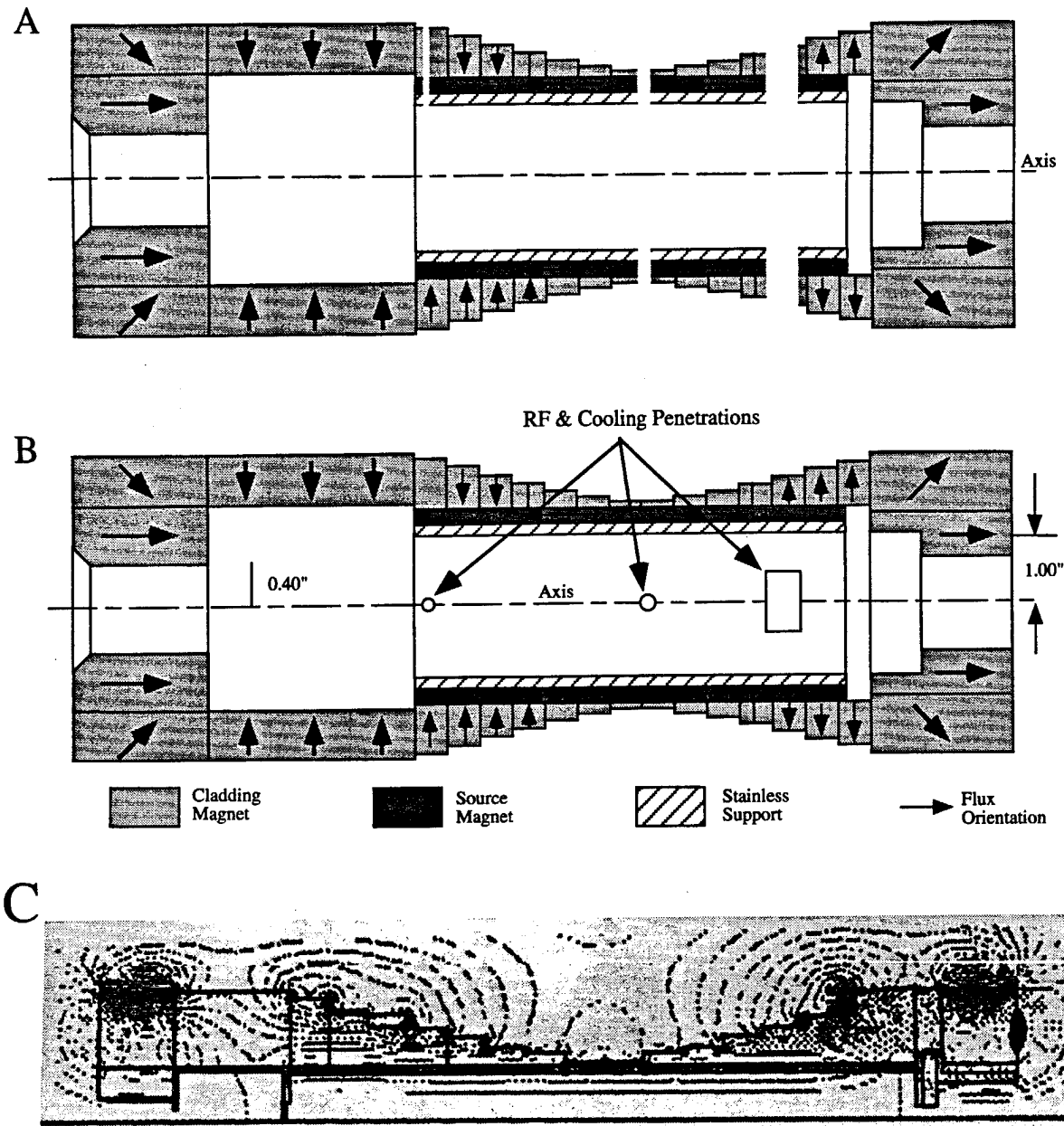

Figure 5. Side (A) and top (B) views of solenoid with access penetrations. (C) Flux plot of B.

Flux Patterns of Basic Field Source and that of the Required Structure

It is rather simple to obtain a nearly perfect solenoidal and confined field (Fig. 4A) if no alterations such as access ports or field-free chambers are required. Figures 5, 6 and 7 show that an acceptable flux uniformity is obtainable within the interaction region even after extensive modifications. Figure 6A shows a measured field that is slightly greater than the theoretical one. This discrepancy is due to use of magnets of slightly higher remanence than that assumed in the calculations.

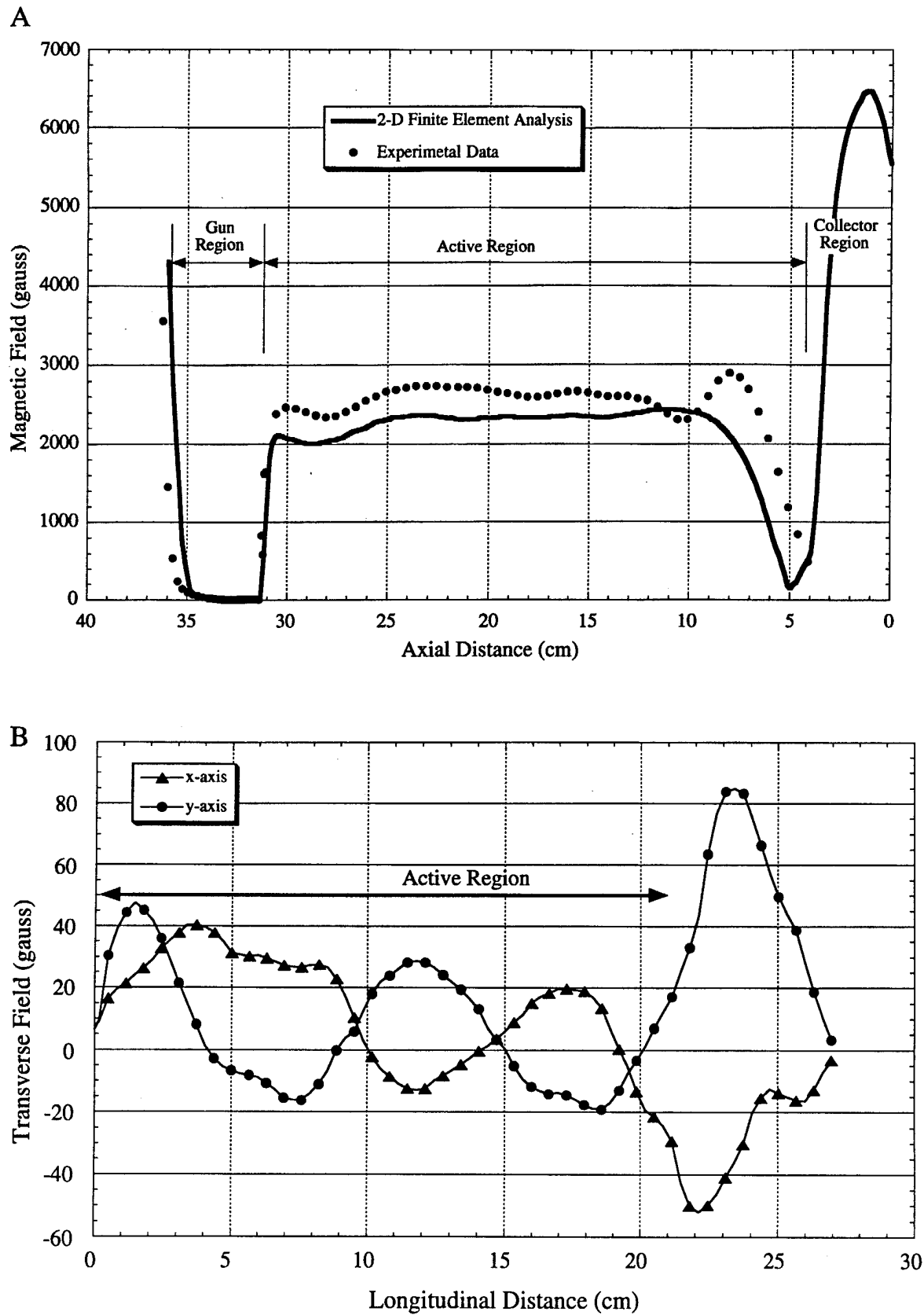

Figure 6. (A) Axial and (B) transverse on-axis fields as a function of distance along the Z axis.

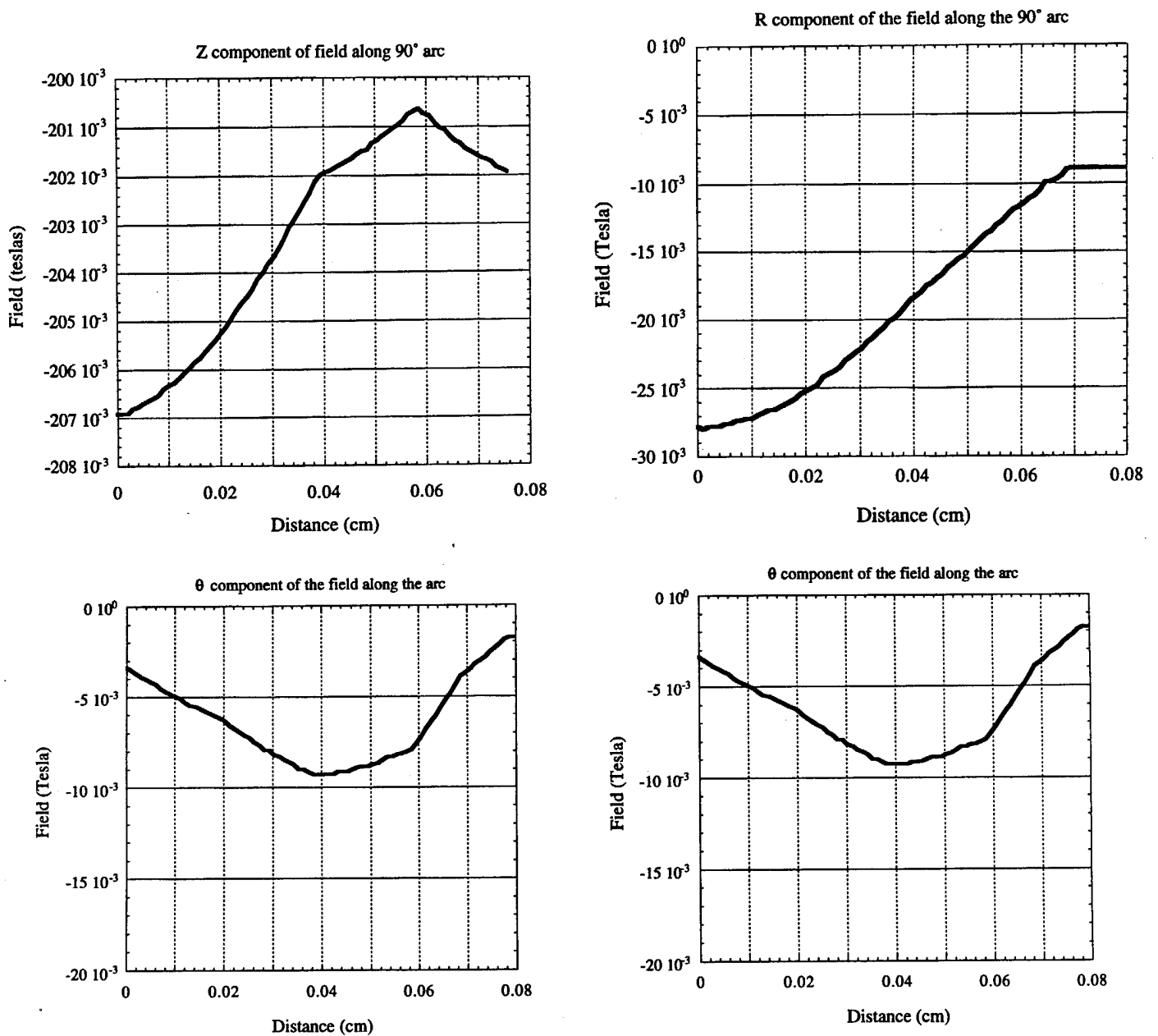

Figure 7. The measured components of the field around the axis of rotation at the waveguide penetrations.

Beam Tester

A beam tester (vacuum assembly only; no RF structure) was constructed to evaluate beam transmission and beam size. The beam tester is vacuum tight and mounted in the magnet assembly of Fig. 8. Work is currently in progress to test and evaluate said assembly. Initial tests (without RF) yielded a 98% beam transmission.

Conclusions

1. A solenoidal field permanent magnet structure appropriate for a linear beam microwave tube was designed.
2. The magnetic design used 2-D Finite Element Analysis.
3. 3-D Finite Element Analysis indicated problems associated with penetration, and modifications were made to compensate.
4. Mechanical design and assembly techniques were worked out to cope with the extremely high forces involved.
5. Magnetic measurements were made on individual pieces to evaluate the uniformity, on the axial and transverse on-axis fields in the completed assembly.
6. Magnetic measurements showed excellent agreement with the theoretical predictions as shown in Fig. 6.

(A)

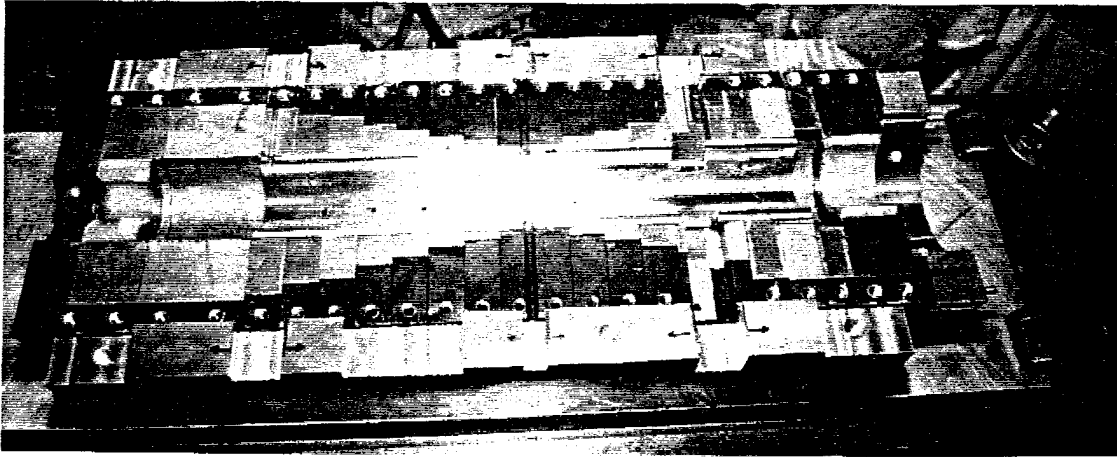

(B)

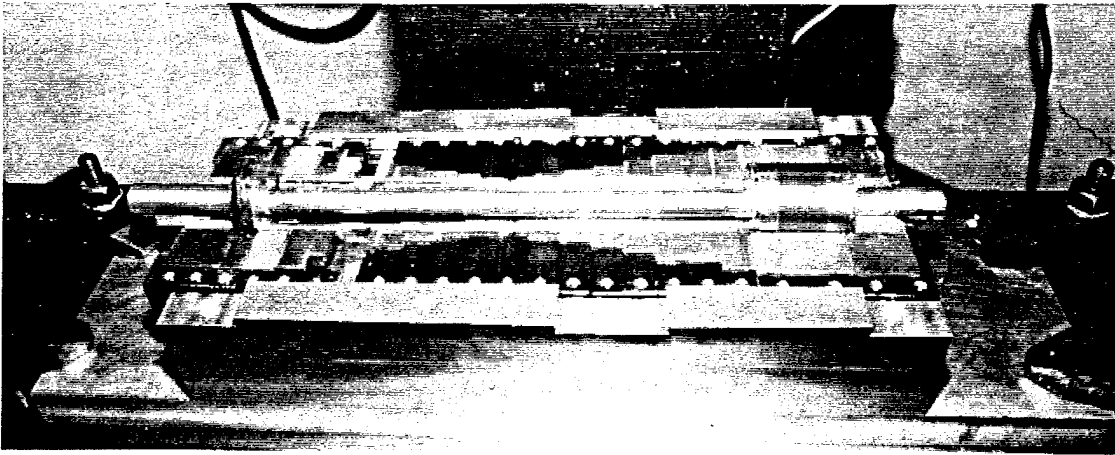

(C)

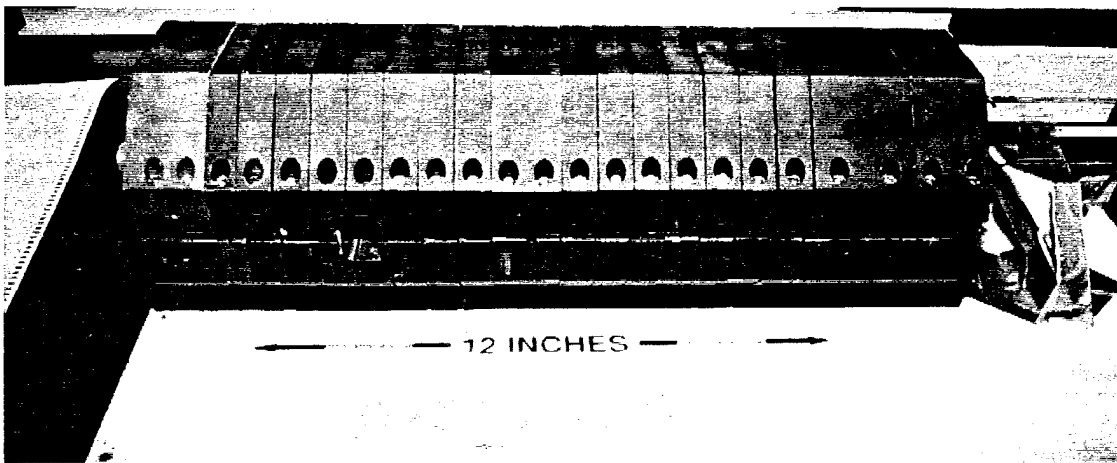
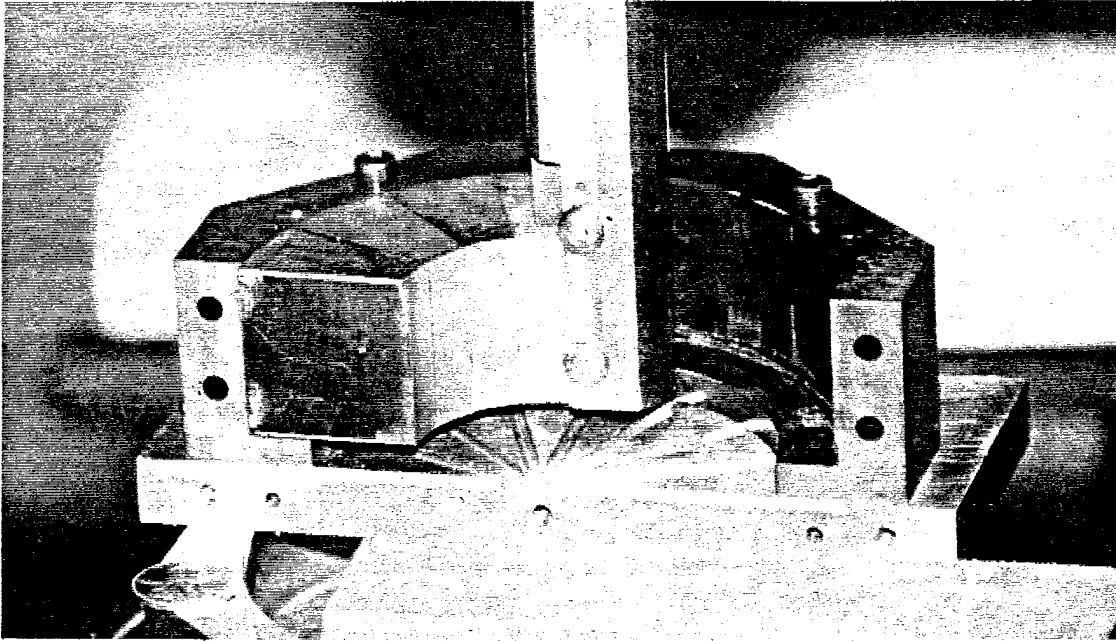

Figure 8. Sectional and assembled views of magnet structure: (A) empty magnet section, (B) magnet section with beam tester in place, and (C) closed, fully assembled structure.

(A)



(B)

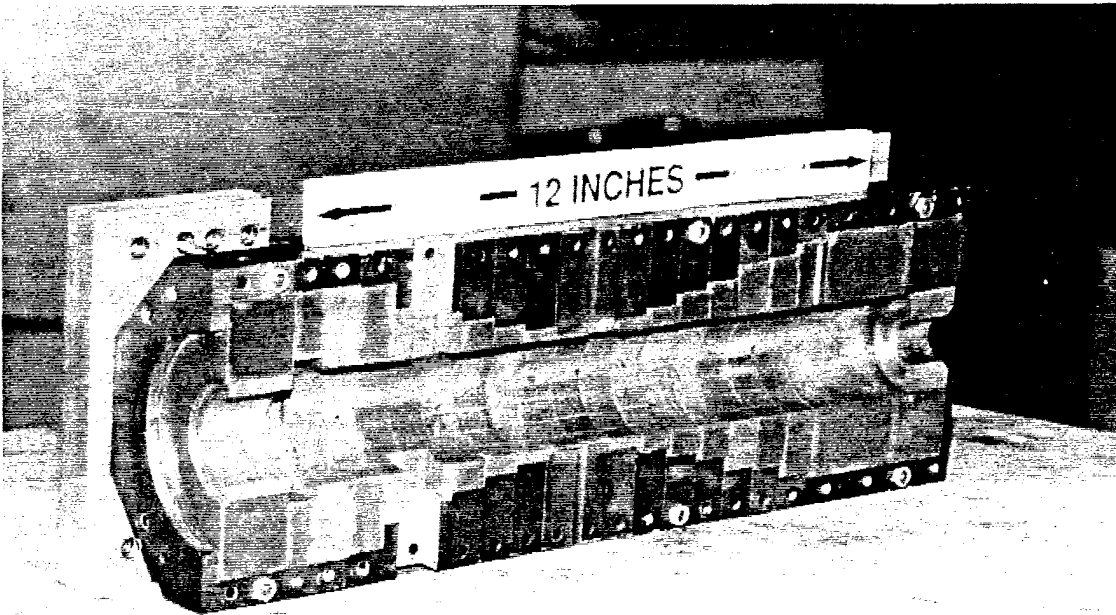

Figure 9. Sectional details of magnet structure. (A) Partial cladding ring in assembly jig , (B) section of assembled magnet.

ARMY RESEARCH LABORATORY
PHYSICAL SCIENCES DIRECTORATE
MANDATORY DISTRIBUTION LIST

August 1995
Page 1 of 2

Defense Technical Information Center*
ATTN: DTIC-OCC
8725 John J. Kingman Rd, STE 0944
Fort Belvoir, VA 22060-6218
(*Note: Two DTIC copies will be sent
from STINFO office, Ft Monmouth, NJ)

Advisory Group on Electron Devices
ATTN: Documents
Crystal Square 4
1745 Jefferson Davis Highway, Suite 500
(2) Arlington, VA 22202

Director
US Army Material Systems Analysis Actv
ATTN: DRXSY-MP
(1) Aberdeen Proving Ground, MD 21005

Commander, CECOM
R&D Technical Library
Fort Monmouth, NJ 07703-5703
(1) AMSEL-IM-BM-I-L-R (Tech Library)
(3) AMSEL-IM-BM-I-L-R (STINFO Ofc)

Commander, AMC
ATTN: AMCDE-SC
5001 Eisenhower Ave.
(1) Alexandria, VA 22333-0001

Director
Army Research Laboratory
ATTN: AMSRL-D (John W. Lyons)
2800 Powder Mill Road
(1) Adelphi, MD 20783-1197

Director
Army Research Laboratory
ATTN: AMSRL-DD (COL Thomas A. Dunn)
2800 Powder Mill Road
(1) Adelphi, MD 20783-1197

Director
Army Research Laboratory
2800 Powder Mill Road
Adelphi, MD 20783-1197
(1) AMSRL-OP-SD-TA (ARL Records Mgt)
(1) AMSRL-OP-SD-TL (ARL Tech Library)
(1) AMSRL-OP-SD-TP (ARL Tech Publ Br)

Directorate Executive
Army Research Laboratory
Physical Sciences Directorate
Fort Monmouth, NJ 07703-5601
(1) AMSRL-PS
(1) AMSRL-PS-T (M. Hayes)
(1) AMSRL-OP-FM-RM
(22) Originating Office

ARMY RESEARCH LABORATORY
PHYSICAL SCIENCES DIRECTORATE
SUPPLEMENTAL DISTRIBUTION LIST
(ELECTIVE)

August 1995
Page 2 of 2

- Deputy for Science & Technology
Office, Asst Sec Army (R&D)
(1) Washington, DC 20310
- Cdr, Marine Corps Liaison Office
ATTN: AMSEL-LN-MC
(1) Fort Monmouth, NJ 07703-5033
- HQDA (DAMA-ARZ-D/
Dr. F.D. Verderame)
(1) Washington, DC 20310
- Director
Naval Research Laboratory
ATTN: Code 2627
(1) Washington, DC 20375-5000
- USAF Rome Laboratory
Technical Library, FL2810
ATTN: Documents Library
Corridor W, STE 262, RL/SUL
26 Electronics Parkway, Bldg 106
Griffiss Air Force Base
(1) NY 13441-4514
- Dir, ARL Battlefield
Environment Directorate
ATTN: AMSRL-BE
White Sands Missile Range
(1) NM 88002-5501
- Dir, ARL Sensors, Signatures,
Signal & Information Processing
Directorate (S3I)
ATTN: AMSRL-SS
2800 Powder Mill Road
(1) Adelphi, MD 20783-1197
- Dir, CECOM Night Vision/
Electronic Sensors Directorate
ATTN: AMSEL-RD-NV-D
(1) Fort Belvoir, VA 22060-5806
- Dir, CECOM Intelligence and
Electronic Warfare Directorate
ATTN: AMSEL-RD-IEW-D
Vint Hill Farms Station
(1) Warrenton, VA 22186-5100