

REPORT DOCUMENTATION PAGE

Form Approved
OMB No. 0704-0188

Public reporting burden for this collection of information is estimated to average 1 hour per response, including the time for reviewing instructions, searching existing data sources, gathering and maintaining the data needed, and completing and reviewing the collection of information. Send comments regarding this burden estimate or any other aspect of this collection of information, including suggestions for reducing this burden, to Washington Headquarters Services, Directorate for Information Operations and Reports, 1215 Jefferson Davis Highway, Suite 1204, Arlington, VA 22202-4302, and to the Office of Management and Budget, Paperwork Reduction Project (0704-0188), Washington, DC 20503.

1. AGENCY USE ONLY (Leave blank) 2. REPORT DATE
03/00/81 3. REPORT TYPE AND DATES COVERED

4. TITLE AND SUBTITLE
ENGINEERING AND DEVELOPMENT SUPPORT OF GENERAL DECON TECHNOLOGY FOR THE DARCOM INSTALLATION RESTORATION PROGRAM, TASK 7, LITERATURE SEARCH AND EVALUATION OF COMPATIBILITY TESTING OF WASTE CONTAINMENT BARRIER MATERIALS

5. FUNDING NUMBERS

DAAK11 80 C 0027

6. AUTHOR(S)
PRICE, D.; SOMMERER, S.

7. PERFORMING ORGANIZATION NAME(S) AND ADDRESS(ES)
ATLANTIC RESEARCH CORPORATION
ALEXANDRIA, VA

8. PERFORMING ORGANIZATION REPORT NUMBER

81336R14

9. SPONSORING / MONITORING AGENCY NAME(S) AND ADDRESS(ES)
ARMY TOXIC AND HAZARDOUS MATERIALS AGENCY
ABERDEEN PROVING GROUND, MD

10. SPONSORING / MONITORING AGENCY REPORT NUMBER

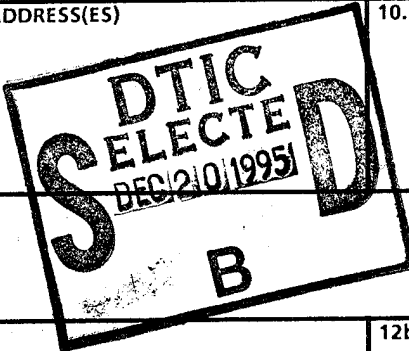

11. SUPPLEMENTARY NOTES

12a. DISTRIBUTION / AVAILABILITY STATEMENT
APPROVED FOR PUBLIC RELEASE; DISTRIBUTION IS UNLIMITED

12b. DISTRIBUTION CODE

13. ABSTRACT (Maximum 200 words)
THIS REPORT EXAMINES THE FEASIBILITY OF PREDICTING LONG-TERM LINER COMPATIBILITY WITH SPECIFIC WASTES BASED ON THE AVAILABLE DATA ON LINERS. THE REPORT IS DIVIDED INTO FOUR MAIN SECTIONS - 1) BENTONITE LINERS, 2) MEMBRANE LINER MATERIALS, 3) POTENTIAL LONG-TERM LINER COMPATIBILITY PREDICTION METHODS, 4) CONCLUSIONS AND RECOMMENDATIONS. IN THE FIRST TWO SECTIONS, THE CHARACTERISTICS OF VARIOUS LINER MATERIALS ARE DESCRIBED. SECTION 3 DISCUSSES TESTING METHODS, LINER SITE APPLICATIONS, AND A MODEL OF BENTONITE COMPATIBILITY WITH INORGANIC SALTS.

19951218 074

14. SUBJECT TERMS
LINERS, BENTONITE, LANDFILL, LAGOON, PVC

15. NUMBER OF PAGES

16. PRICE CODE

17. SECURITY CLASSIFICATION OF REPORT
UNCLASSIFIED

18. SECURITY CLASSIFICATION OF THIS PAGE

19. SECURITY CLASSIFICATION OF ABSTRACT

20. LIMITATION OF ABSTRACT

FILE COPY

DRAFT

81336R14

ENGINEERING AND DEVELOPMENT SUPPORT OF GENERAL DECON
TECHNOLOGY FOR THE DARCOM INSTALLATION RESTORATION PROGRAM

Original

Task 7. Literature Search and Evaluation of Compatibility Testing
of Waste Containment Barrier Materials

March 1981

Debra A. Price
Suzette Sommerer

Rocky Mountain Arsenal
Information Center
Commerce City, Colorado

Submitted to:

U.S. Army Toxic and Hazardous Materials Agency
Aberdeen Proving Ground (Edgewood Area), Maryland 21010

Attn: DRXTH-TE-F

Contract No. DAAK11-80-C-0027

Submitted by:

ATLANTIC RESEARCH CORPORATION
5390 Cherskes Avenue
Alexandria, Virginia 22314



Disclaimer

The views, opinions and/or findings contained in this report are those of the authors and should not be construed as an official Department of the Army position, policy or decision unless so designated by other documentation.

Disposition

Destroy this report when it is no longer needed. Do not return it to the originator.

Accession For	
NTIS GRA&I	<input checked="" type="checkbox"/>
DTIC TAB	<input type="checkbox"/>
Unannounced	<input type="checkbox"/>
Justification	
By _____	
Distribution/	
Availability Codes	
Dist	Avail and/or Special
A-1	

DISPOSITION FORM

For use of this form, see AR 340-15, the proponent agency is TAGCEN.

File

REFERENCE OR OFFICE SYMBOL

SUBJECT

DRXTH-TE-A

Draft Technical Report - Evaluation of Compatibility Testing of Waste Containment Barrier Materials

TO ✓ Chief, ISD
Chief, FSD
Chief, ESD

FROM Chief, Tech Div

DATE 2 APR 1981 CMT 1
Mr. Asselin/caf/2054

1. Atlantic Research Corporation has completed the literature search and industrial survey of methods to predict material compatibility of bentonite clay and various polymer liners.
2. Please review the attached report and provide comments to Mr. Mike Asselin by 10 Apr 81.

1 Incl
as

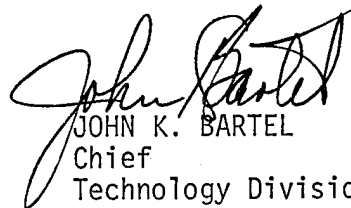
JOHN K. BARTEL
Chief
Technology Division

Rocky Mountain Arsenal
Information Center
Commerce City, Colorado

FILE COPY

UNCLASSIFIED

SECURITY CLASSIFICATION OF THIS PAGE (When Data Entered)

REPORT DOCUMENTATION PAGE		READ INSTRUCTIONS BEFORE COMPLETING FORM
1. REPORT NUMBER	2. GOVT ACCESSION NO.	3. RECIPIENT'S CATALOG NUMBER
4. TITLE (and Subtitle) Engineering and Development Support of General Decor Technology for the DARCOM Installation Restoration Program. Task 7 - Lit Search & Eval of Compatibil- ity Testing of Waste Containment Barrier Materials		5. TYPE OF REPORT & PERIOD COVERED Final June 1980 - March 1981
7. AUTHOR(s) Debra A. Price, Suzette Sommerer		6. PERFORMING ORG. REPORT NUMBER 49-5002-07-0001
9. PERFORMING ORGANIZATION NAME AND ADDRESS Atlantic Research Corporation 5390 Cherokee Avenue Alexandria, Virginia 22314		8. CONTRACT OR GRANT NUMBER(s) DAAK11-80-C-0027
11. CONTROLLING OFFICE NAME AND ADDRESS DCASR Philadelphia P.O. Box 7730 Philadelphia, Pennsylvania 19101		10. PROGRAM ELEMENT, PROJECT, TASK AREA & WORK UNIT NUMBERS
14. MONITORING AGENCY NAME & ADDRESS (If different from Controlling Office) U.S. Army Toxic and Hazardous Materials Agency Aberdeen Proving Ground (Edgewood Area), Maryland 21010		12. REPORT DATE March 1981
		13. NUMBER OF PAGES 70
		15. SECURITY CLASS. (of this report) Unclassified
		15a. DECLASSIFICATION/DOWNGRADING SCHEDULE
16. DISTRIBUTION STATEMENT (of this Report) Approved for public release, distribution unlimited		
17. DISTRIBUTION STATEMENT (of the abstract entered in Block 20, if different from Report)		
18. SUPPLEMENTARY NOTES Contract Project Officer: Mr. Michael Asselin (DRXTH-TE-D)		
19. KEY WORDS (Continue on reverse side if necessary and identify by block number)		
liners	butyl rubber	polyethylene
liner materials	chlorinated polyethylene	polyvinyl chloride
lagoons	chlorosulfonated polyethylene	PVC
landfill	Hypalon®	PE, CPE, neoprene, EPDM
bentonite	ethylene propylene rubber	elastized polyolefin
20. ABSTRACT (Continue on reverse side if necessary and identify by block number) The objective of this study was to review and evaluate information on com- patibility and compatibility testing of liner/barrier materials with hazardous wastes. The emphasis of the study was on methods of long-term and accelerated compatibility testing and models to predict liner compatibility with various wastes. Very little information is available on long-term compatibility with various lining materials. Essentially no methods are available for predicting membrane liner compatibility with hazardous wastes. A model of bentonite compat- ibility has been developed to some extent. Further development of this model		

UNCLASSIFIED

SECURITY CLASSIFICATION OF THIS PAGE(When Data Entered)

should lead to a method to theoretically predict the compatibility of various hazardous wastes with bentonite.

UNCLASSIFIED

2 SECURITY CLASSIFICATION OF THIS PAGE(When Data Entered)

SUMMARY

The objective of this study was to identify and evaluate methods of predicting material compatibility of various containment barriers with several specific contaminants. The barrier materials considered were bentonite clay, butyl rubber, nylon reinforced butyl rubber, ethylene propylene rubber, polyethylene, chlorinated polyethylene, chlorosulfonated polyethylene, polypropylene, polyvinyl chloride, polychloroprene, and elasticized polyolefins. Contaminants of interest were dimethylmethylphosphonate (DMMP), diisopropylmethylphosphonate (DIMP), aldrin, sulfone, chloride, sulfate, sodium, trinitrotoluene (TNT), cyclotrimethylene trinitramine (RDX), and dinitrotoluene (DNT).

At the present time, there have been very few long-term tests of synthetic liner compatibility with hazardous materials. Short-term tests to predict long-term performance are being developed, but these accelerated tests may not accurately reflect long-term stability. In general, liner compatibility for a particular waste is a function of the polymer used, the formulation of the material, particularly the addition of plasticizers and other additives, and the physical processing of the material. In view of the variety and complexity of synthetic liner materials/waste interactions, it is not likely that a predictive model will be found to estimate synthetic liner performance.

A theoretical model of interactions between bentonite and inorganic salts has been developed by soil scientists and is presented here. This model can perhaps be extended to include organics and other wastes, however, it will be important to verify the predictions of the model experimentally.

NOTHING
ON THIS
PAGE. JUST
THE
NUMBER

TABLE OF CONTENTS

	<u>Page</u>
1473.....	1
Summary.....	3
I. Introduction.....	9
A. Objective.....	9
B. Background.....	9
II. Bentonite Clay Liners.....	11
A. Properties of Bentonite Clay Liner Materials.....	11
B. Testing of Bentonite Clay Materials for Performance.....	11
C. Experience with Liners in Actual Use.....	20
III. Membrane Liners.....	24
A. Installation Consideration.....	24
B. Types of Membrane Liner Materials Available.....	27
C. Testing of Membrane Liners for Performance.....	31
D. Past Experience with Membrane Liners.....	53
IV. Predictive Models of Liner Failure.....	56
A. Bentonite Liners.....	56
B. Synthetic Membrane Liners.....	61
V. Conclusions.....	64
VI. Recommendations.....	66
VII. References.....	67

LIST OF FIGURES

<u>Number</u>		<u>Page</u>
1.	<u>Diagrammatic Representation of the Succession of Layers in the Lattice of Hydrated Montmorillonite.....</u>	12
2.	Effect of Calcium-Sodium Ion Exchange on Seepage Rates of Compacted Bentonite and Compacted Bentonite-Polymer Sealants..	13
3.	Standard Clay-lined Lagoon with a Protective Soil Cover and Rip-rap.....	14
4.	Normalized Column Effluent Concentrations for Lead (100 ppm) as a Function of pH of Leachate Passed Through a Column Containing 8% Clay.....	16
5.	Effect of Clay Liner Thickness on Ionic Concentration in an Aquifer with Various Ground Water Velocities.....	19
6.	Schematic Drawing of Exposure Cell for Clay Liners.....	21
7.	Scrim Reinforcing of Membrane.....	25
8.	Common Field Seams.....	26
9.	Typical Anchor Trench Design.....	28
10.	Schematic of a Test Cell Apparatus for Membrane Liners.....	34
11.	Individual Polyethylene Immersion Tank for Liner Compatibility Tests.....	36
12.	Schematic Drawing of Leachate Generator and Cell in Which the Liner Materials Were Exposed to Leachate Under Conditions Simulating Sanitary Landfills.....	41
13.	Detail of the Base of the Leachate Generator Showing the Refuse, the Sand Cover, and the Liner.....	42
14.	Schematic Drawing of Exposure Cell for Membrane Liners.....	44
15.	Schematic of Osmosis Bag Assembly.....	51
16.	Scaled Potential as a Function of Solution Concentration, Distance from, and Charge Density of Mineral Surfaces.....	58
17.	Interparticle Distances as a Function of NaCl Concentration at Several Applied Pressures.....	60
18.	Comparison of Experimental and Predicted Swelling Pressures.....	62

LIST OF TABLES

<u>Number</u>		<u>Page</u>
I.	Comparative Performance of Bentonite and Saline Seal Bentonite in a Soil Test.....	17
II.	Water Vapor Permeability of Polymeric Membrane Lining.....	32
III.	Analysis of Leachate for Liner Compatibility Tests.....	35
IV.	Comparison of the Swelling Characteristics of Membrane Liner Materials Immersed in Water and in Leachate.....	37
V.	Water Absorption of Selected Membrane Liner Materials at Room Temperature and at 70°C.....	38
VI.	Summary of the Effects of Immersion of Polymeric Membrane Liners in Leachate for 8 Months.....	39
VII.	Swelling of Polymeric Membrane Liners by Landfill Leachate - Leachate Content of Exposed Membrane Liner Materials in Percent.....	43
VIII.	Effects of Immersion of Liner Materials in Hazardous Wastes.....	45
IX.	Effects of Hazardous Wastes on Liners Exposed in Test Cells.....	48
X.	Tests of Membrane Liner Bags Filled with Leachate - Permeability of Membranes to Water and to Ions Due to Osmosis.....	52
XI.	Summary of Resistances of Liner Materials to Lagoon and Landfill Conditions.....	65

NOTHING
ON THIS
PAGE JUST
A NUMBER

I. INTRODUCTION

A. Objective

The objective of this study was to review and evaluate available information on compatibility and compatibility testing of barrier/liner materials with various hazardous wastes. The barrier/liner materials which were evaluated in this study were bentonite clay and various formulations, thereof; butyl rubber and reinforced butyl rubber; chlorinated polyethylene; chlorosulfonated polyethylene; ethylene propylene rubber; polyethylene and polyvinyl chloride. The specific contaminants of interest in this study were dimethylmethylphosphonate, diisopropylmethylphosphonate, aldrin, sulfone, chloride, sulfate, sodium, trinitrotoluene (TNT), dinitrotoluene (DNT) and hexahydro-1,3,5-trinitro-1,3,5-triazine (RDX). However, due to the limited data base on liner compatibility in general, all available information on liner compatibility with wastes was evaluated in the hope that predictive compatibility parameters could be identified.

B. Background

Lagooning and landfilling of hazardous wastes have been common practice for many years. Lagoons were devised to prevent liquid hazardous wastes from being discharged into the nation's streams, rivers and lakes. Landfills were supposed to contain solid and semisolid wastes in an environmentally safe manner and eliminate the unsightly open dumping. Both of these disposal methods were not only aimed at containment of the wastes but also reduction in volume through compaction, or evaporation and reduction in toxicity through microbial degradation. However, in the era when lagooning and landfilling became acceptable practices, little attention was given to potential contamination of the nations' most valuable water resource - the ground water. As a result of this shortsightedness, many landfills or lagoons were built close to aquifers, in highly permeable soil or in some cases the aquifer penetrated the landfill. In general, these sites were unlined and the leachates moved into near-by aquifers contaminating the ground water. The disastrous effects of improperly designed lagoons and landfills are only now being fully recognized as more and more of the ground water becomes contaminated and whole communities are forced to find other sources of drinking water.

Techniques to improve landfill and lagoon construction have come under study during the last 10-20 years. These techniques include more thorough evaluation of the site geohydrology and the use of liners to slow down the movement of leachates and help contain the wastes. Many of the early liner materials used for landfills or lagoons were materials commonly used in the construction industry as barriers. These materials included concrete, asphalt, clay and soil mixtures of clay. These materials were commonly thought to be impermeable and little attention was paid to their actual permeability and the effects of different types of wastes on their permeability. The high costs of construction associated with these early liner materials and unsatisfactory performances led to the development of synthetic liner membranes of low

permeability. Although waste compatibility was an initially recognized problem with synthetic liners, only limited compatibility studies were performed with the original waste to be landfilled or lagooned. Very little attention was focused on waste variability by either the users or the membrane liner installer. As a result, many of these liners failed as plant process improvements were made and the characteristics of the liquid and solid effluents changed.

The U.S. Army faces similar problems to the chemical industry in containing its hazardous chemical wastes. Most of the Army's explosives manufacturing facilities are 40-50 years old. The waste lagoons or landfills were constructed during the time period when little thought was applied to protecting ground water reserves. Many of the lagoons used to contain explosives wastes are in this category. Lagoons constructed at a later time to hold toxic wastes were better planned and liner material was installed to contain the wastes. However, liner waste compatibility studies were limited and even these new lagoons have the potential for contamination of the ground water.

Even with the recognition of the importance of protection of the ground water resources and the problems of waste-liner compatibility, very little work has been done on long-term waste compatibility. The ability to predict long-term liner-waste compatibility from a data base is essentially non-existent. Therefore, there is a great need for long-term waste/liner compatibility studies, development of accelerated compatibility tests and theoretical predictions of compatibility. The problem of long-term waste compatibility with membrane liners is further complicated by the fact that liner materials put into the field 10-20 years ago no longer exist as commercial products. These membrane liner materials are constantly undergoing improvement and reformulation. Therefore, the data base on long-term compatibility for these materials is non-existent.

This report examines the feasibility of predicting long-term liner compatibility with specific wastes based on the available data on liners. The report is divided into four main sections--1) bentonite liners, 2) membrane liner materials, 3) potential long-term liner compatibility predictions methods, and 4) conclusions and recommendations. In the first two sections, the characteristics of the various liner materials are described. This description is followed by the available information on testing methods and compatibility. Liner site applications, including success and failures, are then described. The last section of the report describes some potential predictive techniques of waste/liner compatibility.

II. BENTONITE CLAY LINERS

A. Properties of Bentonite Liner Materials

Bentonite is a clay that is colloidal in nature and whose particles have a plate-like shape. It is comprised largely of montmorillonite and carries a negative lattice charge which is usually compensated by Na^+ , Ca^{++} , and K^+ (Grim, 1979). Sodium bentonite, often called Wyoming or Western bentonite, is known for its ability to adsorb water on the surface of its platelets (American Colloid Co., 1971), as shown in Figure 1. Adsorption of water causes the bentonite to swell from 10 to 15 times its dried volume (American Colloid Co., 1978). This swelling capability makes bentonite valuable as a sealant. When mixed with a loose soil and properly hydrated, the bentonite will fill the voids in the soil, creating a highly impervious barrier (American Colloid Co., 1978). The ratio of sodium to calcium in the clay affects its swelling characteristics. The greater the sodium content, the larger the quantities of water adsorbed (Clark and Moyer, 1974). Because of the plastic nature of bentonite, minor punctures or tears due to earth movements or sharp objects will eventually seal themselves (Williams, 1978).

High concentrations of dissolved salts in the permeant will cause sodium bentonite to undergo cation exchange. The loss of the sodium ions reduces the clay's swelling capacity, resulting in shrinking and cracking and eventual failure of the seal (American Colloid Co., 1978). Several companies offer bentonite in combination with other materials, such as polymers, to make them more resistant to chemicals and dissolved salts, as shown in Figure 2 (Middlebrooks et al., 1978). One such company, American Colloid, has done extensive testing on their processed bentonite products, and have found their Volclay SLS-70 to be compatible with virtually all organic and inorganic contaminants, allowing them to give a 30 year warranty on this product (Kinard and Tuenge, 1979).

Besides cation exchange, other problems to consider with clay liners are piping, drying out and weed growth. Piping occurs when the fine clay particles are washed or diffused out of the soil matrix causing increased permeability. The moisture content of a clay must also be carefully controlled to prevent drying out and cracking. These problems can be alleviated by placing a protective blanket of soil over the liner (Middlebrooks et al., 1978) and a layer of crushed stone or "rip-rap", as shown in Figure 3, where the seal might be exposed to erosion (American Colloid Co., 1978). In areas of excessive weed growth, it is not advisable to use a clay liner, as weeds and tree roots would puncture the liner. Burrowing animals also can puncture the liner and clay liners are not recommended for areas having large populations of these animals (Middlebrooks et al., 1978).

B. Testing of Bentonite Clay Materials for Performance

Natural in situ clays are frequently more impermeable than remolded clays, therefore, it is best to leave clays intact when possible. However, in

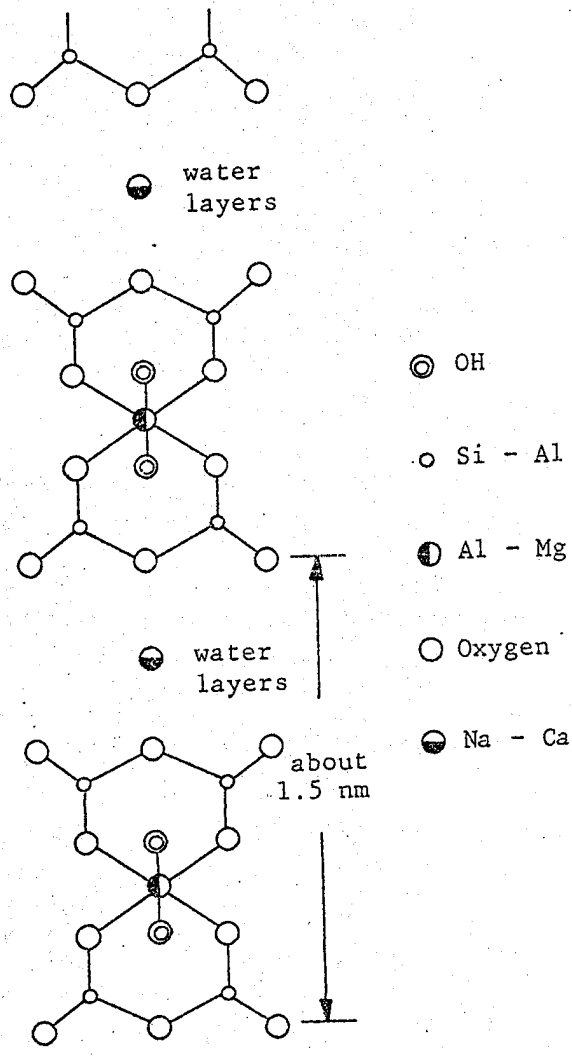

Figure 1. Diagrammatic Representation of the Succession of Layers in the Lattice of Hydrated Montmorillonite (Grim, 1979).

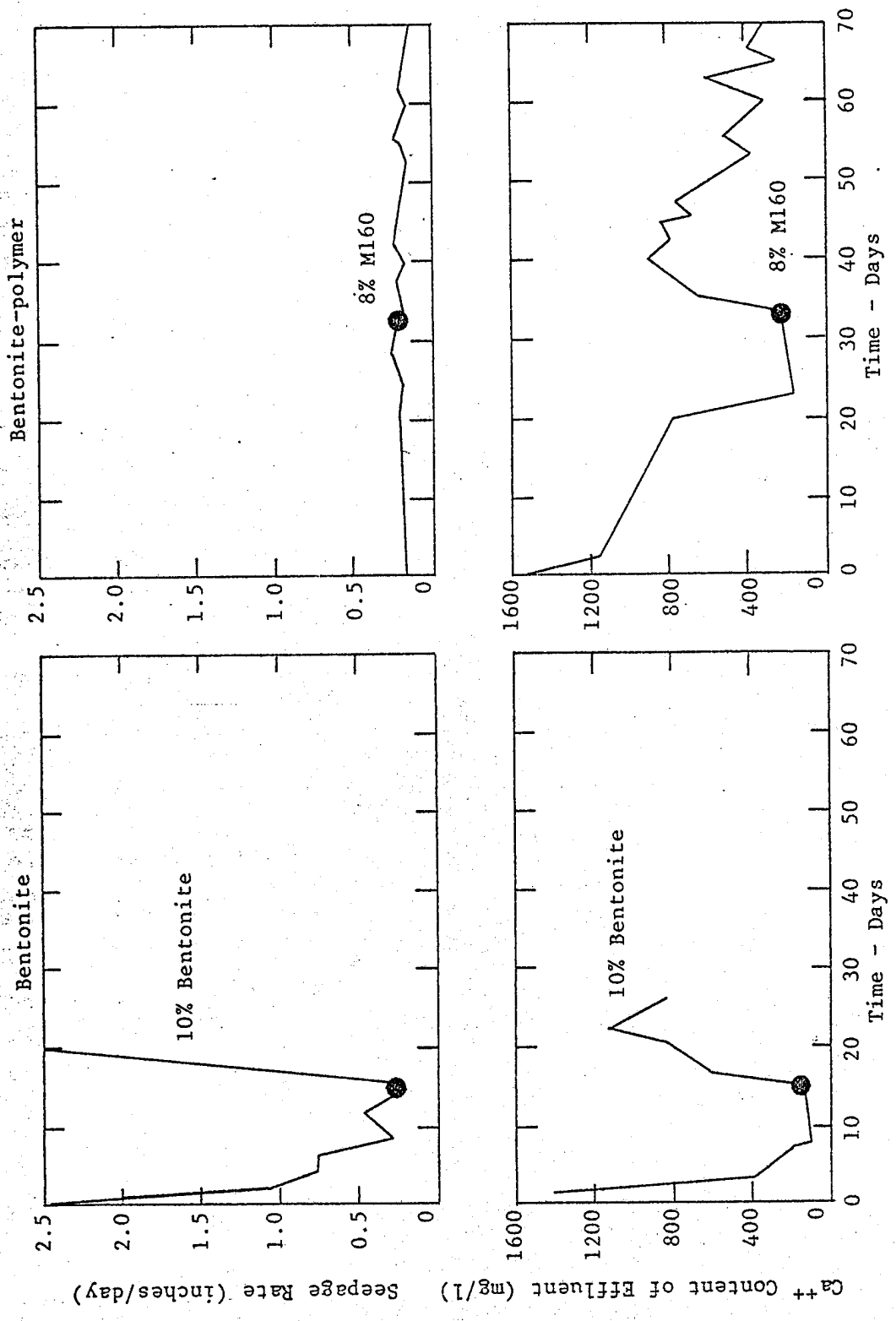

Figure 2. Effect of Calcium-Sodium Ion Exchange on Seepage Rates of Compacted Bentonite and Compacted Bentonite-polymer Sealants (Middlebrooks et al., 1978).

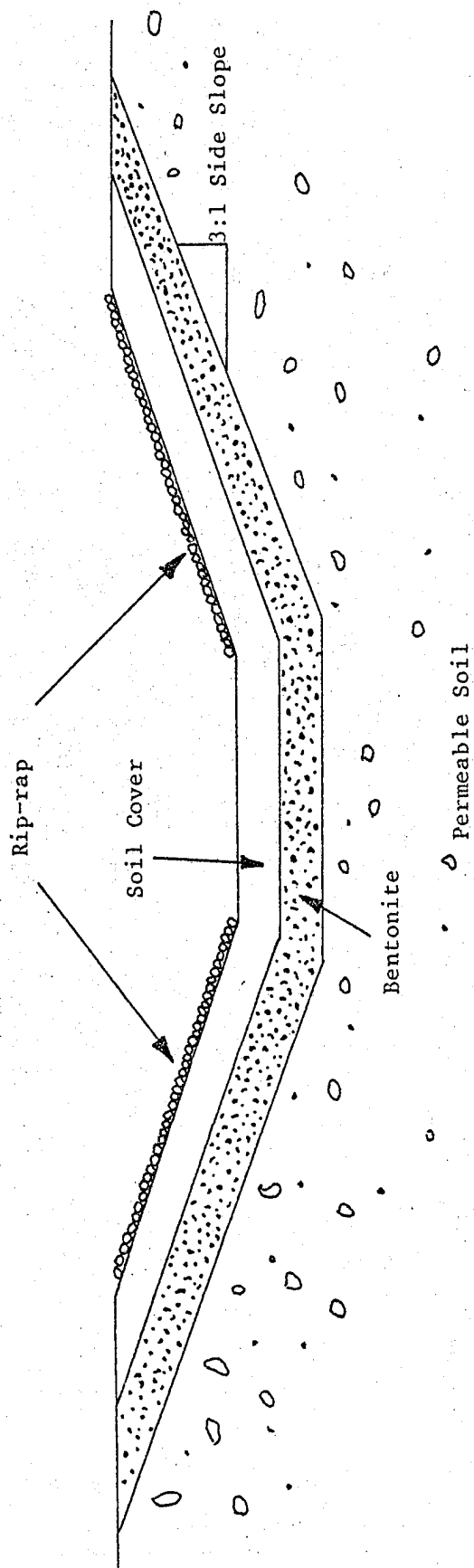

Figure 3. Standard Clay-lined Lagoon with a Protective Soil Cover and Rip-rap (American Colloids Co., 1978).

most cases, suitable clays have to be imported. Many difficulties encountered in the past with clay linings have been attributed to improper design and construction of the liner (Middlebrooks et al., 1978). Because of these failures, several studies have been conducted to determine the optimum methods of constructing bentonite liners. Clark and Moyer (1974) studied three methods of construction of bentonite clay liners:

- Bentonite was mixed with soil in a ratio of 1 to 8 and applied both on the surface of the area and buried under a blanket
- A 1.25 cm bentonite layer was applied and topped with 15 cm of soil
- A bentonite suspension was applied to the surface.

Of the construction methods studied, the buried mixture and the buried membrane were the most effective (Clark and Moyer, 1974). The surface application of the bentonite suspension was very unsuccessful. Through experience and testing, it has been determined that bentonite liners are most effective when applied to an empty lagoon, mixed at a rate of 5 to 15% by volume with a loose silty soil, compacted, and covered by a protective blanket of soil (Middlebrooks et al., 1978).

The effectiveness of a clay liner can only be estimated by performing permeability studies with the liner material under laboratory or field conditions. Several parameters and tests have been developed to help predict the effectiveness of a liner in the field:

- cation ion exchange capacity (CEC)
- porosity of the soil--amount of solids per unit volume
- pore volume displacement (PVD) - ratio of liquid which passes through a soil to the void volume of the soil without consideration of the bentonite in the void
- contaminants to bentonite ratio (C/B) is the ratio of the weight of NH_4Cl which passes through the seal to the weight of bentonite in the seal. This test helps to judge the longevity of the seal on the basis of the exposure to contaminants (Gupta and Miles, 1979)
- microstructural arrangement of the solid material.

There is strong evidence to indicate that cation exchange is the principal property affecting attenuation (Griffin and Shimp, 1975).

The seal is effective if it contains adequate exchangeable sodium to compensate for the wastes that are being stored in the lagoon. If excessive ion exchange occurs, then the liner will deteriorate and eventually fail (Middlebrooks et al., 1978). Cation exchange capacities of bentonite vary greatly with pH (Smith, 1976) affecting the permeability and attenuation as shown in Figure 4.

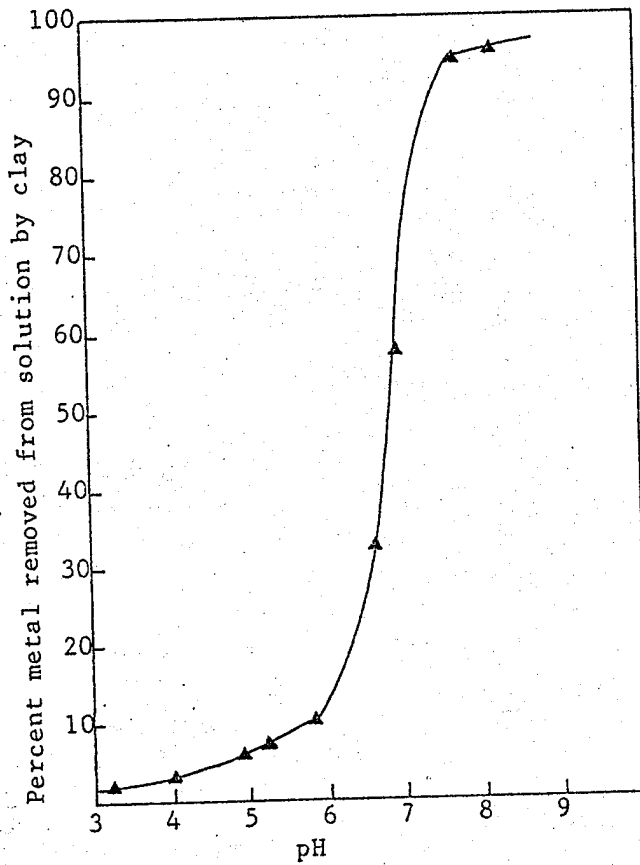

Figure 4. Normalized Column Effluent Concentrations for Lead (100 ppm) as a Function of pH of Leachate Passed Through a Column Containing 8% Clay (Griffin and Shimp, 1975).

Polymer treated bentonites are more resistant to cation exchange caused by high amounts of dissolved salts in the permeate as shown in Table I.

Table I. Comparative Performance of Bentonite and Saline Seal Bentonite In a Soil Test

Day	Prehydrated Bentonite		Prehydrated Saline Seal	
	Permeability* (cm/sec)	Leakage Rate** cm	Permeability* (cm/sec)	Leakage Rate** cm
1	1.0×10^{-6}	0.318	1.0×10^{-6}	0.318
2	2.0×10^{-6}	0.635	1.0×10^{-6}	0.318
3	5.0×10^{-6}	1.905	0.8×10^{-6}	0.254
4	1.0×10^{-5}	3.18	0.9×10^{-6}	0.284
5	6.0×10^{-5}	19.1	0.7×10^{-6}	0.221
7***	1.0×10^{-4}	31.8	0.7×10^{-6}	0.221

* 1.0×10^{-6} cm/sec represents an effective seal

** Loss of water at a 1.22 m head

*** Seal failed

The contaminated water used in the test contained 3.1% sodium chloride and 3.6% sodium sulfate (Fung, 1980).

Griffin and Shimp (1975) performed tests on clay with sterilized and unsterilized samples of effluent containing heavy metals and salts (sulfates and chlorides). In addition to the effect of pH and CEC on attenuation, it was also found that biological growth reduces hydraulic conductivity. Ionic strength of the leachate also affected the absorption of ions by the clays. With leachates of high ionic strength, the adsorption of a given ion was lower than observed at the same concentration in solutions of lower ionic strength (Griffin and Shimp, 1975).

The porosity of deteriorated clays exposed to divalent cations can be reduced by treating the clays with monovalent cations such as sodium, potassium or ammonium. The added monovalent cations are exchanged for the divalent cations returning some of the swelling capacity to the clay (Middlebrooks *et al.*, 1978).

In an investigation of uranium mill tailings containing sulfate and uranium, Staub and Triegel (1978) found the attenuation of the leachate was related to the thickness of the liner. For thicker liners, the ionic components

of the uranium mill tailings leaching into the ground water were less than that observed for thinner liners. The concentration of ions in the ground water was also dependent on the ground water flow rate with less concentration observed at higher flow rates. Data from this investigation are presented in Figure 5.

A study of the effects of acids, phenols and heavy metals on the permeability of five Texas clays was reported by Middlebrooks et al. (1978). The initial permeabilities of the clays ranged from 0.13 to 1.60×10^{-10} cm/sec. Strong acids increased the permeabilities of the clays while heavy metals and phenolic-like substances had little effect on the permeabilities (Middlebrooks et al., 1978).

Styron and Fry (1979) tested clay liner compatibility with flue gas desulfurization sludge containing heavy metals, chloride, cyanide, nitrite, nitrate, sulfite and sulfate. M-179, a processed polymer/bentonite blend from Dow Chemical, was mixed 4% with silty-clay as suggested by the manufacturer, compacted and cured for 7 days at 25.6°C under 50% humidity. The sludge was added and the pressure increased up to 9.1 meters of head. The clay liner leaked and after 12 months developed an obvious odor indicative of breakdown.

Stewart (1978) performed compatibility studies with processed bentonite and several industrial wastes. The processed bentonite chosen was American Colloid's Volclay Saline Seal. From the study, it was determined that the processed bentonite was not compatible with the following sludges:

- caustic petroleum sludge containing strong alkali, salts and small amounts of hydrocarbons
- acidic steel pickling wastes
- heavy metal electroplating sludge.

The bentonite was compatible with:

- oily refinery sludge
- organic pesticide wastes
- organic pharmaceutical wastes
- rubber and plastic wastes containing some oil and grease.

Long term hazardous sludge and liner compatibility studies have been conducted by Haxo and associates at Matrecon, Inc. in Oakland, California. Two polymer bentonites were used in these studies both of which were claimed by the manufacturer to be more effective in the presence of dissolved salts than unmodified bentonite. The bentonites were mixed with 6, 12 and 20% sand to give liners ranging in permeabilities from 10^{-7} to 10^{-9} cm/sec. The wastes used in the studies were lead wastes, saturated and unsaturated oils, pesticides, aromatic oils, and acidic and caustic wastes. Preliminary screening tests eliminated acidic and caustic wastes from further testing due to the poor performance of the

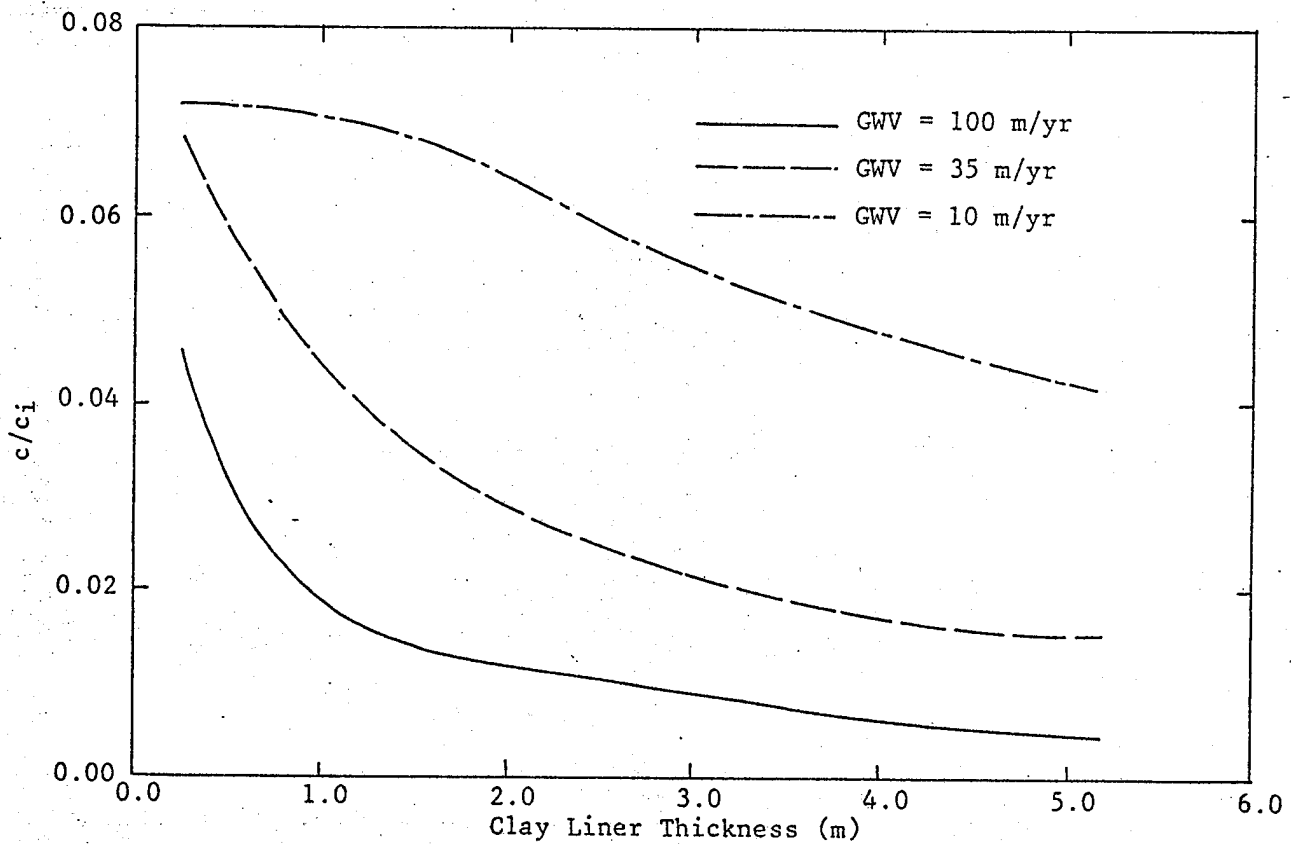

Figure 5. Effect of Clay Liner Thickness on Ionic Concentration (c/c_i) in an Aquifer with Various Ground Water Velocities (GWV) (Staub and Triage, 1978).
 Waste Pit = 1067 m x 224 m x 18 m.
 Distance From Pit = 10,000 m.

liners in the presence of these materials. Ten exposure cells, as diagrammed in Figure 6, were set up for long-term testing (Haxo *et al.*, 1977). After three years of exposure, there was measurable seepage in seven of the ten exposure cells, with one of the types of bentonite allowing slightly less seepage than the other. The liner of one cell containing oily waste failed completely. Despite the type of waste, the general quality of the collected seepage through the liners was very similar, indicating some pollutant attenuation. There was a great deal of channeling into the clay liners, some of which could be avoided by a protective soil cover. Because of channeling and seepage, it was concluded that the liner materials would probably not be satisfactory for long-term storage of pesticides, aromatic oils, or lead wastes (Haxo, 1980).

Organics will affect the ability of a clay to form a good seal. Montmorillonites readily adsorb polar or positively charged organics on their interlayer surfaces. There is significant shrinkage if the interlayer water is displaced by fluids that would yield smaller interlayer spacing. If the water is displaced unevenly, cracking will occur. Organic acids and bases will also dissolve the portions of a clay structure containing aluminum, iron, alkali metals, alkaline earths, and silica (Brown *et al.*, 1980). Brown of Texas A&M has tested the effects of organics on two montmorillonites. The organics changed the permeabilities of the clays from 10^{-8} or 10^{-9} cm/sec to 10^{-3} or 10^{-5} cm/sec. The tests were conducted using a standard permeameter with a pressure head. Water was used to determine the initial permeability. The organics were then applied to the system. The organics caused the clay to shrink and crack, allowing seepage (Brown, 1980).

C. Experience with Liners in Actual Use

The City of Jacksonville in Florida designed a hazardous waste cell at a sanitary landfill site in Duval County. They wanted to contain various acids, pesticides, paints, solvents, and waste oil sludge. Because of the differing types of wastes to be stored, they chose a Volclay liner, a processed bentonite which professes to be compatible with a wide variety of chemical wastes. Since the water table was only 1.5 meters below the surface of the ground, dewatering ditches had to be used to depress the water table 1.5 meters below the bottom of the cell. Lowering of the ground water table was necessary to prevent leachate from seeping into the ground water, and also to keep the ground water from percolating into the bottom of the cell. A 10 cm layer of Volclay SLS-70 was used with a 30 cm soil blanket to prevent mechanical failure. Neutralization of wastes was required prior to acceptance by the facility. Regular monitoring of all surface and ground water is performed, including scans for chromium, copper, lead, lindane, heptachlor, aldrin, heptachlor epoxide, DDE, dieldrine, endrine, methoxychlor, and toxaphene. After 1 year of operation, no seepage has been detected (Kinard and Tuenge, 1979).

Vertac, Inc., a manufacturer of agricultural farm chemicals in West Memphis, Arkansas, needed an equalization pond for adjusting the pH of their waste material. These wastes contain a volatile mixture of acids and solvents which range in pH from 5 to 10. The pond had to contain the wastes and prevent seepage into the ground water and the Mississippi River. The volatile nature of the waste would cause depolymerization of most membrane liner materials, so

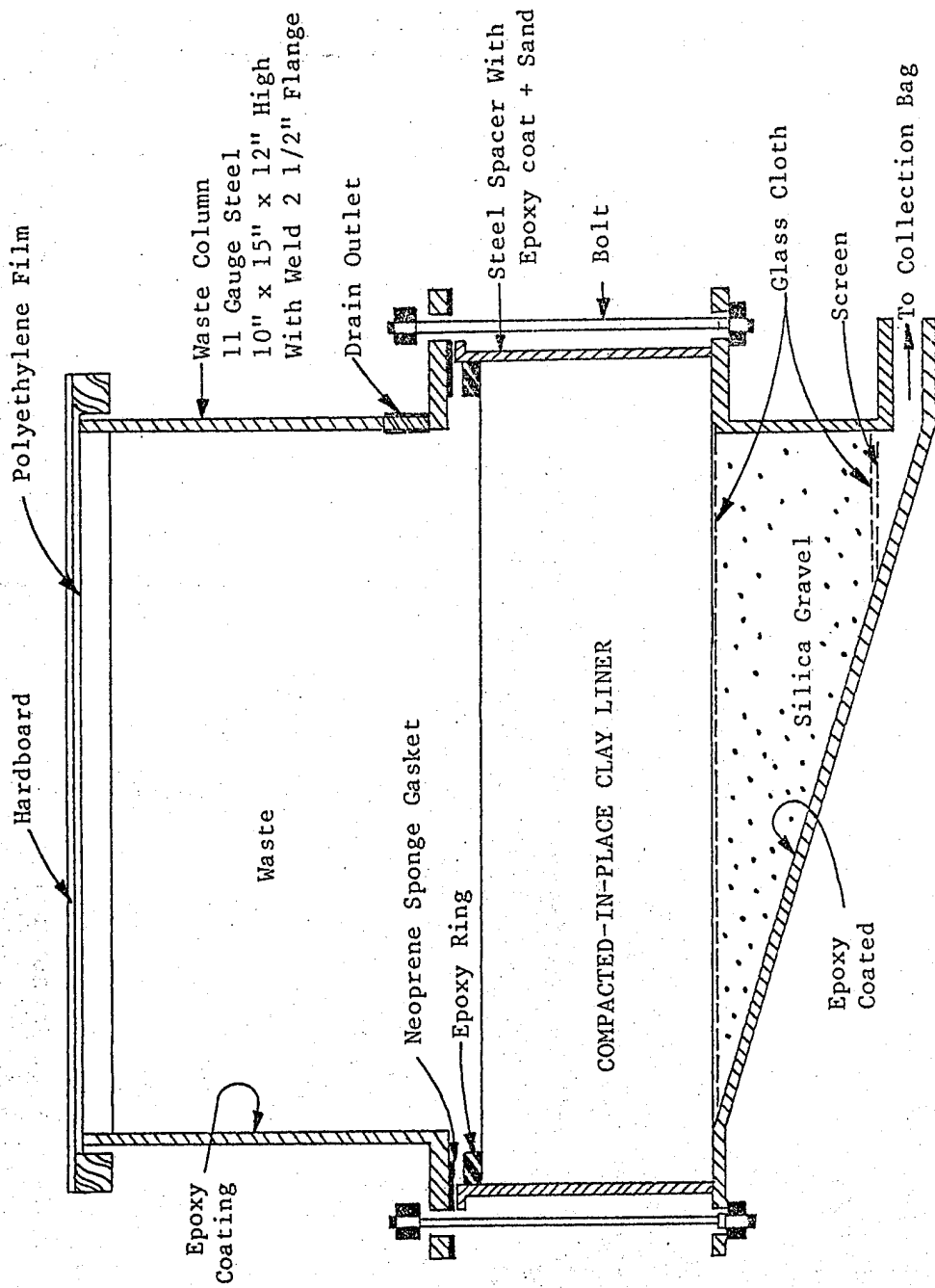

Figure 6. Schematic Drawing of Exposure Cell for Clay Liners (Haxo et al., 1977)
 Exposed area of liner is ca 12 in. by 15 in. and depth of the waste is 1 foot.

Volclay was chosen. After the first year, there was no sign of seepage (Chemical Processing, 1979).

Some companies reject clay liners for various reasons. Pollution Abatement Services of Oswego, New York collects commercial solvents, waste oils, acids, bases, and organic liquids in water. They ruled out a clay liner because it would still be slightly permeable, which was unacceptable in their application. Akron, Ohio wanted a basin for storm drainage. They rejected clay because it would be washed away with the volume of water it would be handling in short periods of time. Another company in Mont Belvieu, Texas turned down clay for their salt water lagoon because of fluctuating water levels, which would allow the clay to dry out. Still other potential users reject clay because it is not available locally. Shipping costs significantly increase the cost of liner installation (Dallaire, 1975).

The Brown Company of Berlin, New Hampshire, needed a lagoon for paper mill effluent. They wanted to use locally available materials instead of synthetic liners, but there was no suitable clay within reasonable handling distance. There were, however, large amounts of glacial till which they mixed with bentonite to form a satisfactory liner. The lagoon was completed in 1976 with a thickness of 30.5 cm upon completion (Johnson and Cole, 1976) and has performed well to the present (Brown Company, 1980).

The Yorktown Power Station of VEPCO has a pond for disposal of cleaning wastes which contain HCl cleaning agents and phosphoric acid based industrial cleaner, in addition to copper and iron in solution and suspended solids of slag, tube corrosion and unburned carbon. The initial pH of the wastes are from 1 to 6. After mixing with lime, a pH of 8.5 to 9 is attained. A processed bentonite liner of Volclay is being used because of its acid resistance (Motley and McKendrick, 1979).

Other utility companies are also using processed bentonite. Rochester Gas and Electric company uses bentonite around their transformers because of its oil resistance. The Pennsylvania Electric Company uses processed bentonite to contain the acid runoff from their coal piles. Duke Power Company has a bentonite lined pond for rinse water, caustic acid, and spent resins (Motley and McKendrick, 1979).

Although Pennsylvania discourages the use of clay liners for landfills (Dallaire, 1975), they will approve natural liners of in situ clay or other geological characteristics which isolate the ground water from leachate. Such is the case of Grunderville Landfill in Pleasant Township, Warren County, which has 15 meters of underlying clay. The McKean County Authority Landfill in Seargeant Township, McKean County also has an in situ clay barrier which varies from one to three meters. Because of strict control, there have been no landfill liner failures in Pennsylvania with the exception of minor mechanical failures (Bucciarelli, 1976).

The Wheeling Disposal Service Company, Inc., of St. Joseph, Missouri had a natural clay liner installed in 1975. This facility accepted mainly herbicide

wastes, the majority of which was atrazine orange. The liner performed satisfactorily until the site had to close due to new permeability regulations (Buntrock, 1980).

Rollins Environmental Services in Wilmington, Delaware owns several disposal sites in the United States, many of them bentonite lined. They had difficulty with some of their liners installed in the early 70's before compatibility studies were performed for particular wastes. These sites contained solvents and very acidic or alkaline wastes, and the liners cracked and deteriorated. Since the earlier failures, Rollins has found bentonite to be compatible with most wastes other than acids, bases, and solvents (Lurcott, 1980).

III. MEMBRANE LINERS

A. Installation Considerations

The use of impervious synthetic membrane liners for lagoons and landfills has gained popularity in recent years. One of the major advantages of a membrane liner is that, for the same degree of impermeability, a membrane takes up considerably less potential storage area of a lagoon than does a clay liner. Membranes also are resistant to a wide range of chemicals and bacteria. They have, however, limited ability to withstand the stress of heavy machinery, lacerations, or punctures (Lee, 1974).

In the production of a membrane liner, raw elastomer is combined with various compounding ingredients determined by the manufacturer, including carbon black, pigments, fillers, plasticizers, accelerators, and antioxidants (Du Pont, undated). The materials used in the fabrication of a liner are either rubber or plastic. Formula variations using different compounding ingredients can produce end products for specific applications (Lee, 1974). After compounding, rubber based materials are converted into rolls of sheeting by calendaring. These sheets are usually 1 to 2 meters wide. Thermoplastics are made into sheeting by extrusion (Du Pont, undated).

Liners sometimes require fabric reinforcement which can be laminated between sheets during calendaring (see Figure 7). Common materials used for the fabric scrim are nylon, dacron, polypropylene, and fiberglass (Stewart, 1978). Fabric reinforcement is used when the side slopes of a lagoon are 2:1 or steeper, when the substrate is rough or abrasion is a factor, where creep is anticipated, where there are long slopes, or where there is considerable wind (Slifer, 1976).

Since the membrane sheeting is produced in relatively narrow strips, a finished liner requires a large number of seams. The quality of the seams is very important to liner success, as a liner is only as good as its weakest seam. Factory seams are generally more reliable than field seams (Du Pont, undated), therefore, it is advisable to prefabricate as much of a liner as possible prior to installation. Most field seams are made with solvents or an adhesive designed for a specific polymer compound (American City and County, 1977). Three common field seams are shown in Figure 8.

Membrane liners are often considered to be exposable or unexposable. Exposable liners are those formulated from materials resistant to ozone and ultraviolet light (UV) for prolonged periods of time. The service life for exposable liners averages from 20 to 25 years. Exposable liners include butyl rubber, EPDM (ethylene propylene rubber), Hypalon® and Neoprene. Unexposable liners have an average life of 10 to 15 years under similar conditions (Stewart, 1978). However, they can function for 20 years or more if covered by a layer of soil or water to prevent UV and ozone attack (Lee, 1974). Unexposable liners include polyvinyl chloride (PVC), polyethylene (PE) and polypropylene (Stewart, 1978).

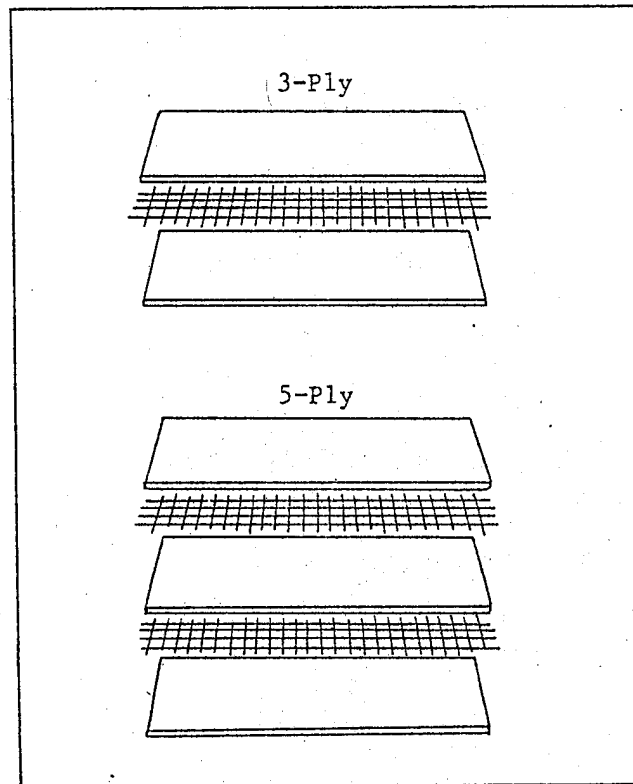

Figure 7. Scrim Reinforcing of Membrane (Burke Rubber Company, undated).

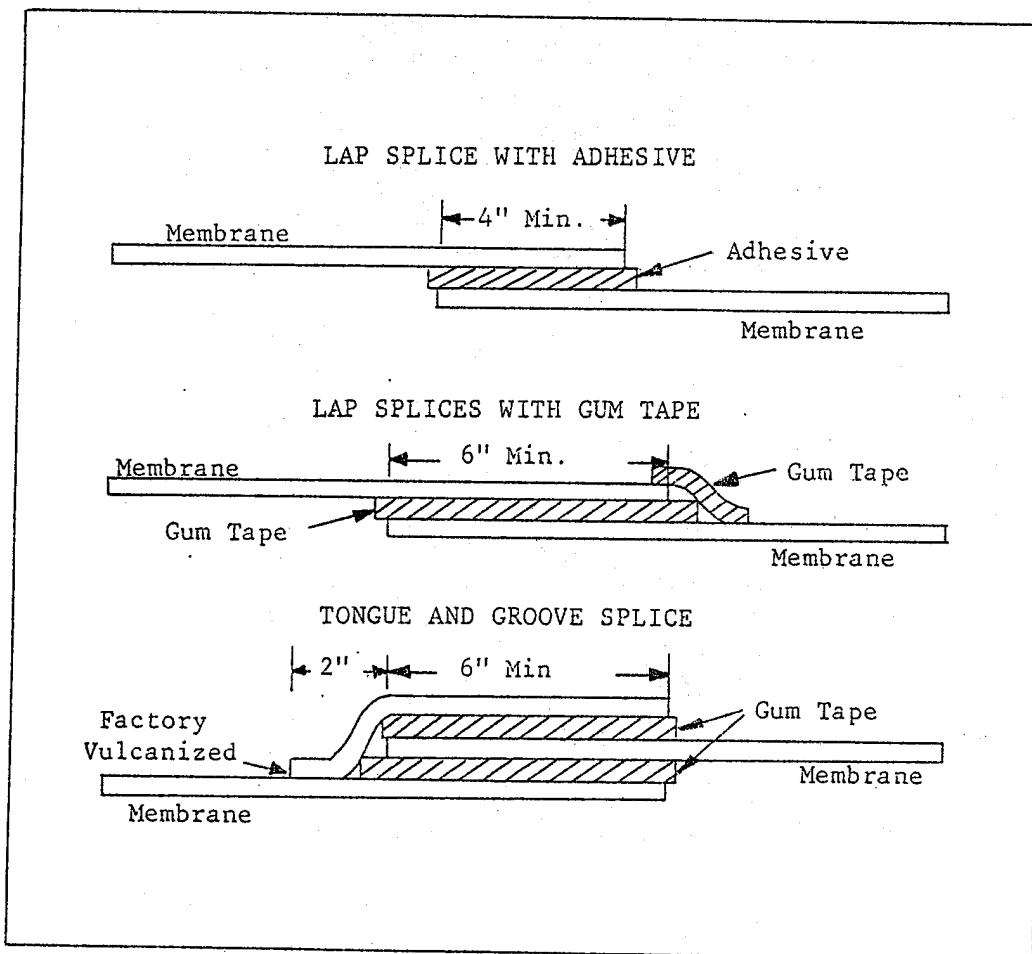

Figure 8. Common Field Seams (Du Pont, undated).

The temperature of the liner environment must be considered before choosing a membrane liner. Low temperatures make membranes brittle and prone to cracking, while at very high temperatures they develop flow characteristics and tend to creep (Fisher, 1980). Temperature also influences the degree of chemical attack of the contained fluids on the membrane (Schlegel, 1977). Sometimes with especially hazardous wastes, it is necessary to use a double liner. If a sandwich type liner is used, such as PVC cemented to CPE, high temperatures cause the compounds to be mutually destructive as the usual plasticizers are not compatible (Gupta and Miles, 1979). This problem can be solved by adding a thin layer of PVC with a different plasticizer between the other layers (Kersten, 1980), or by separating the two liner materials with a layer of about 0.3 meters of sand (B.F. Goodrich, 1978).

Prior to installation of a membrane liner, the site must be excavated, contoured, and smoothed. Sometimes a blanket of sand is put down before the liner. An anchor trench is dug around the perimeter to hold the liner in place (Du Pont, undated) as shown in Figure 9. To avoid local stresses, there should be some play in the sheet to allow for slight ground movement and contraction due to temperature changes. Other potential problems which must be taken into considerations during installation of membrane liners are ventilation of subsurface gases, drainage due to a high water table or surface runoff, leak detection, and water and settled solids extraction (Schlegel, 1977). It is recommended that thin membrane linings be covered with a layer of earth to help prevent mechanical damage (Staff Industries, 1980) and to also add the necessary weight to avoid gas accumulations and resist wind damage to banks above the liquid level (Gupta and Miles, 1979).

B. Types of Membrane Liner Materials Available

Common liner materials include Hypalon®, butyl rubber, EPDM, CPE, neoprene, polyethylene, polypropylene, PVC® and elasticized polyolefin. With all of these liners, proper compounding is imperative.

Hypalon®, or chlorosulfonated polyethylene, was developed by Du Pont. It is a synthetic rubber, but is often categorized with plastics because it has similar properties when initially manufactured (Williams, 1978). The Hypalons® contain at least 45% of the rubber. The rest of the formulation primarily is fillers (American City and County, 1977). Hypalon® liners are made of laminated sheets to avoid pinhole punctures and are available both reinforced and unreinforced (Williams, 1978). The reinforced liner uses a nylon or polyester scrim which gives it good puncture resistance (Haxo *et al.*, 1977). It is advisable to use reinforced Hypalon®, especially on slopes. Unreinforced Hypalon® has the tendency to either shrink, or stretch and tear (Kersten, 1980).

Hypalon® has exceptional resistance to weathering, ozone, UV, and moderate resistance to oils and growths of mold, mildew, fungus, and bacteria (Steward, 1978). It resists oxidizing chemicals such as sulfuric acid and hypochlorites, inorganic aqueous solutions, and has moderately good resistance to many organics (Du Pont, undated), although swelling does occur when exposed to aromatics (Williams, 1978). Although available vulcanized, Hypalon® is usually

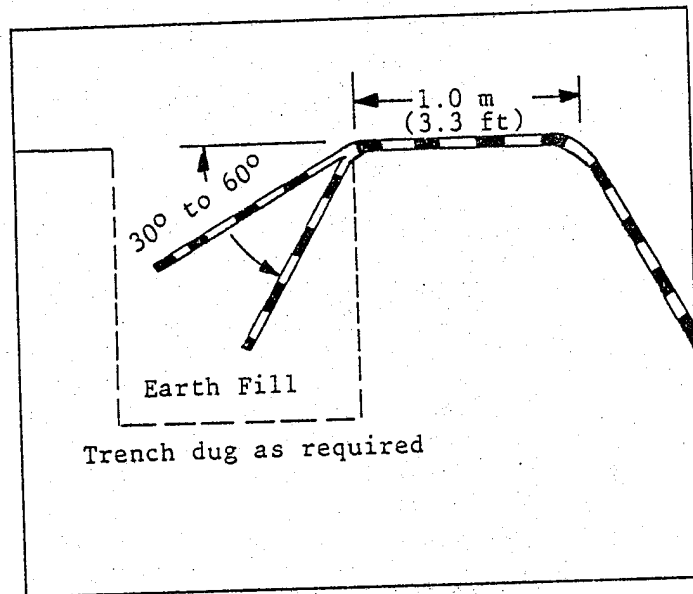

Figure 9. Typical Anchor Trench Design (Schlegel, 1977).

supplied unvulcanized because the unvulcanized material is easier to seam. While seaming is being done, the material should be shielded from the sun because it will slowly vulcanize on its own with exposure to UV light. Hypalon® has an average service life of more than twenty years without a soil cover (Stewart, 1978). Hypalon® can be produced in colors, is very tolerant to temperature extremes (Du Pont, undated), and has a reported permeability of 10^{-10} cm/sec (Williams, 1978). Hypalon®'s major drawback is its relatively low tensile strength (Stewart, 1978).

PVC, or polyvinyl chloride, was first developed in Germany (Williams, 1978). It is usually supplied unsupported and contains 30-50% plasticizers. There are a wide variety of plasticizers that can be compounded with PVC, the choice of which depends on the application. Most of the problems encountered with PVC liners are due to the plasticizers. The polymer itself holds up well in burial tests, however the plasticizers are often biodegradable, and some are slightly soluble in water (Haxo et al., 1977). PVC is not resistant to ozone, UV radiation, or weathering; therefore, it must be covered with a layer of soil or something of greater weatherability (Stewart, 1978). When the plasticizer is lost, whether by extraction or volatilization, PVC will stiffen and lose its resistance to tear and shock, shrink and often become hard (Williams, 1978). The plasticizers have also been found to be addictive to rodents, who chew holes in the liners (Schlegel, 1977). If precautions are taken, PVC has good tolerance to a wide range of chemicals, oils, greases, and solvents, and has good resistance to punctures and abrasions (Stewart, 1978). Polyvinyl chloride is available in regular and oil resistant compounds depending on the plasticizers in the formulation. PVC swells in aromatic hydrocarbons (Kersten, 1980) and is susceptible to strain from sulfides (Lee, 1974). PVC liner material is seamed easily, however difficulty is encountered at low temperatures (Stewart, 1978).

Butyl rubber is a copolymer containing 97% isobutylene and small amounts isoprene. It is available in reinforced and unreinforced vulcanized sheets (Haxo et al., 1977). The permeability of butyl rubber liner is 10^{-10} cm/sec. This low permeability is due to its tightly packed molecular structure, which also makes it very difficult to seam (Williams, 1978). Butyl rubber has good resistance to ozone and UV radiation. It is extremely impermeable to water, remains flexible with temperature extremes, resists punctures, and has good tensile and tear strength (Stewart, 1978). Average service life of a butyl rubber liner is 20 years. This material has poor resistance to hydrocarbon solvents, but excellent resistance to water based inorganic salts, sewage, oxidizing chemicals, and animal and vegetable fats and oils (Geswein, 1975).

EPDM, or ethylene propylene rubber, is a terpolymer of ethylene, propylene and a small amount of a diene monomer (Haxo et al., 1977). This material is very similar to butyl rubber and was developed in an effort to produce a liner material with better ozone resistance than butyl rubber. Ethylene propylene terpolymer (EPT, or Nordel) was developed at the same time. The two materials are almost identical and are often used interchangeably in a mixture with butyl rubber. The overall aging characteristics of EPDM and EPT are slightly better than butyl rubber. The permeabilities of these liner materials are 10^{-10} cm/sec (Williams, 1978). EPDM is resistant to ozone, UV, abrasion, dilute solutions of acids, alkalis, silicates, phosphates, and brine, and is tolerant of temperature

extremes (Stewart, 1978). However, EPDM is not recommended for use with petroleum, aromatic, or hydrocarbon solvents (Lee, 1974). Both materials are available in supported and unsupported vulcanized sheets and are difficult to seam (Haxo et al., 1977).

Neoprene, or polychloroprene, is a chlorinated synthetic rubber (Stewart, 1978) that was introduced by Du Pont. It is resistant to oily wastes; however, when it was used in sheet form, it was reported attacked by crude oil wastes (Williams, 1978). If properly compounded, neoprene will resist degradation from ozone, sunlight, waxes, fats, oils, greases, alkalies, dilute mineral acids, inorganic salt solutions, molds, and mildew. It has a good high temperature range and resists puncture and abrasion. Neoprene is available in vulcanized sheets that are difficult to seam in cold, damp weather (Du Pont, undated).

PE, or polyethylene, is a highly flexible thermoplastic that has excellent low temperature serviceability. It has poor puncture resistance and weatherability unless either formulated with carbon black or UV absorbers, or covered with a protective layer of soil (Stewart, 1978). Polyethylene has good tensile strength (Lee, 1974), is chemically inert, and has great resistance to bacteria (American City and County, 1977). PE has a permeability of 1.5×10^{-9} cm/sec (Williams, 1978), but thinner membranes are prone to leaking because of pinholes (American City and County, 1977). Thicker sheets of high density polyethylene are effective sealants, but flexibility is sacrificed. Polyethylene has been used to contain water, sewage, industrial effluents, municipal wastes, insecticides, poisons, oils, and chemicals (Schlegel, 1977). Seams are usually heat welded in the factory, while gum tape is often used in the field (American City and County, 1977).

Although polypropylene is prone to attack by UV and ozone without carbon black, it is tolerant to many chemicals and temperature extremes, especially high temperatures. It has good tensile strength and low permeability to water, but it is difficult to seam in the field and is not recommended for oxidizing solvents (Stewart, 1978).

CPE, or chlorinated polyethylene, was introduced by the Dow Chemical Company. It utilizes no plasticizers and, therefore, weathers very well (Williams, 1978). It is often used with other plastics and rubbers to improve their crack resistance (Geswein, 1975). CPE is not susceptible to ozone attack, has good tensile and elongation strength, and is very serviceable at low temperatures. It does, however, have limited tolerance for many chemicals, oils, and acids unless properly compounded. CPE is generally supplied in an unvulcanized form in either reinforced or unreinforced sheets. It can be seamed easily with solvents or heat (Stewart, 1978). Permeability of CPE is 10^{-10} cm/sec. It swells on exposure to aromatics (Williams, 1978) but resists burning and microbial attacks (Haxo et al., 1977).

The 3110TM and 3111TM elasticized polyolefins are thermoplastics developed by Du Pont. Elasticized polyolefins are available unvulcanized and unsupported and are easily heat seamed in the factory and the field. They have excellent resistance to UV and ozone and are very serviceable from -60°C to 70°C.

These polyolefins resist attacks from mold, mildew, fungi and bacteria, withstand exposure to water, acids, alkalies, alcohols, ketones, and glycols, and have limited resistance to hydrocarbon solvents, chlorinated hydrocarbons, turpentine, and gasoline (Du Pont, undated). Elasticized polyolefins have been used successfully to contain hydrofluoric acid, hydrochloric acid, dichloromethane and carbon tetrachloride, and have been found to be generally unaffected from a pH of 2 to 13.5 (Williams, 1978). Elasticized polyolefins are not recommended for use on steep slopes or in wet marshy area, and require special protection in high winds areas (Du Pont, undated).

Polyester elastomer is a thermoplastic rubber that is still in an experimental stage. It is resistant to oils and can be heat sealed (Haxo et al., 1977).

Typical water vapor transmission data for the various liner materials obtained using ASTM E-96, Method BW are presented in Table II. The permeability values observed were not only a function of the basic polymer type but also a function of the compounding of the material, as can be seen from the variation of the values within the basic polymer type. Of the materials tested, elasticized polyolefin and one sample of butyl rubber had the lowest permeabilities. The polyvinyl chloride materials had the highest permeability.

C. Testing of Membrane Liners for Performance

Accelerated compatibility testing of membrane liner materials is usually performed at elevated temperatures, which is not always accurate. At high temperatures, liner materials often develop flow characteristics (Fisher, 1980), lose plasticizers, or are subject to attack by certain chemicals, any of which would cause a liner to appear unsuitable when it might function perfectly well under normal temperature conditions.

The National Sanitation Federation (NSF) has been working to develop a standard testing procedure which is scheduled to be published early in 1981. The general procedure involves taking 10 specimens of a liner material and performing physical tests on them (i.e. weight, tensile and elongation), after which they are put in a bath of the expected chemical environment at a slightly elevated temperature of 70°C. Every seven days for four weeks, the sample is weighed. If the weight has not stabilized in four weeks, this part of the test is continued until stabilization has been attained. After weight stabilization, the tensile and elongation are again determined. If the weight change is no greater than 3% and the tensile and elongation changes are no greater than 10%, then the material should be good for at least 20 years (Vandervort, 1980). Loss of elongation by loss of plasticizer or excessive swelling can result in membrane breakage (Haxo, 1980). However, in estimating the performance of a liner material, consideration must also be given to the effects of climate, seam strength, biological attack, UV radiation, ozone, etc. (Vandervort, 1980).

Although accelerated testing is a good method of quickly screening membranes, long-term exposure tests at room temperature should give better results because they simulate actual conditions more closely (Stewart, 1978).

Table II. Water Vapor Permeability of Polymeric Membrane Liners, ASTM E-96, Method BW^a (Haxo, 1979)

Polymer	Liner No.	Thickness		Test time, days	Rate of water vapor transmission, g/d·m ²	Water vapor permeance, 10 ⁻² g/d·m ² ·mmHg (metric perm)	Water vapor permeability, 10 ⁻³ g/d·m ² ·mmHg·cm (metric perm·cm)
		mils	cm				
Butyl rubber	22	73.3	0.185	49	0.097	0.75	1.39
	57	33.5	0.085	21	0.020	0.17	0.15
Chlorinated polyethylene	12	33.3	0.085	28	0.264	2.10	1.76
	38	32.3	0.082	21	0.361	2.90	2.35
	77	31.0	0.079	21	0.320	2.80	2.10
	86	21.0	0.053	28	0.643	5.10	2.72
Chlorosulfonated polyethylene	3	31.0	0.079	32	0.634	5.00	3.97
	6 ^b	37.0	0.094	40	0.422	4.21	3.79
	55	35.0	0.089	42	0.438	3.47	3.09
Elasticized polyolefin	36	28.3	0.072	28	0.142	1.20	0.85
Ethylene-propylene rubber	8	67.0	0.170	28	0.172	1.40	2.52
	18	48.5	0.123	28	0.314	2.49	3.07
	26	38.0	0.097	28	0.327	2.80	2.72
	41	20.0	0.051	21	0.270	2.15	1.09
	83	37.0	0.094	28	0.190	1.50	1.42
Neoprene	9	61.0	0.159	21	0.237	1.90	2.89
	42	20.0	0.051	42	0.304	24.1	1.22
	43	31.5	0.080	28	0.448	3.90	3.12
	82	61.2	0.155	63	0.240	2.00	3.11
Polyester elastomer	75	8.0	0.020	21	10.50	91.0	18.2
Polyvinyl chloride	11	30.0	0.076	21	1.85	16.0	12.2
	17	20.0	0.051	35	2.97	24.0	12.0
	19	21.0	0.054	42	2.78	22.0	11.8
	40	32.5	0.083	42	4.17	33.0	27.3
	59	33.0	0.084	21	4.20	36.0	30.2
	89	20.5	0.052	35	2.94	23.0	12.1
	89	11.0	0.028	35	4.42	35.0	9.77

^aAverage temperature, 72°F; average relative humidity, 42%.

^bfabric-reinforced.

Very little long-term work has been done. Henry Haxo (1976, 1977, 1979, 1980) has performed long-term liner compatibility studies with leachates and hazardous wastes, while Styron and Fry (1979) have done similar studies with flue gas desulfurization wastes.

The membranes tested by Styron and Fry (1979) were elasticized polyolefin and T-16, which is a nylon reinforced neoprene. For the tests, the membranes were placed in the apparatus shown in Figure 10. Flue gas desulfurization sludge was added and the system was pressurized to simulate 9 meters of head. Flue gas desulfurization sludge contains numerous heavy metals, chlorides, nitrates and sulfates. Physical tests on the liner material were run before the exposure and after 12 months of exposure. After exposure, the breaking strengths of these liner materials decreased. The elongation of the elasticized polyolefin increased and remained the same for the T-16.

Haxo has done extensive long-term research on liner compatibility. In the leachate study, membranes were exposed to landfill leachate in immersion tests and in simulated landfills. The chemical characteristics of the leachate used in these tests are presented in Table III. In the immersion tests, butyl rubber, CPE, Hypalon®, elasticized polyolefin, EPDM, Neoprene, polybutylene, polyester elastomer, PE, and PVC were exposed to leachate in the apparatus shown in Figure 11. This apparatus allowed double sided exposure of the membrane material accelerating the test slightly. Several studies were conducted with the liner materials in the apparatus. These studies included

- a comparison of the swelling characteristics of the membrane in water and in leachate
- effect of temperature on water absorption by the membranes
- effects of eight months immersion in leachate on the physical properties of the membrane.

The swelling characteristics of the plastic and rubber liner materials can be used as a predictive tool for liner life since swelling generally reduces mechanical properties and measures permeability.

The results of these liner immersion studies are presented in Tables IV-VI. As shown in Table IV, immersion in the leachate generally resulted in greater swelling of the membrane materials than water immersion. Of the materials examined in this test, the chlorosulfonated polyethylene exhibited the greatest swelling (10.9% in water after 44 weeks and 13.3% in leachate for 32 weeks). In contrast, the elasticized polyolefin exhibited essentially no swelling in either the water or leachate.

The effects of high temperatures on the water absorption characteristics of the 10 liner material samples are compiled in Table V. Most of the liner materials showed a significant increase in water absorbed at 70°C over that at room temperature within 1 week of exposure. After 100 weeks of exposure, the amount of water absorption of the membranes exposed at 70°C ranged from .17 to

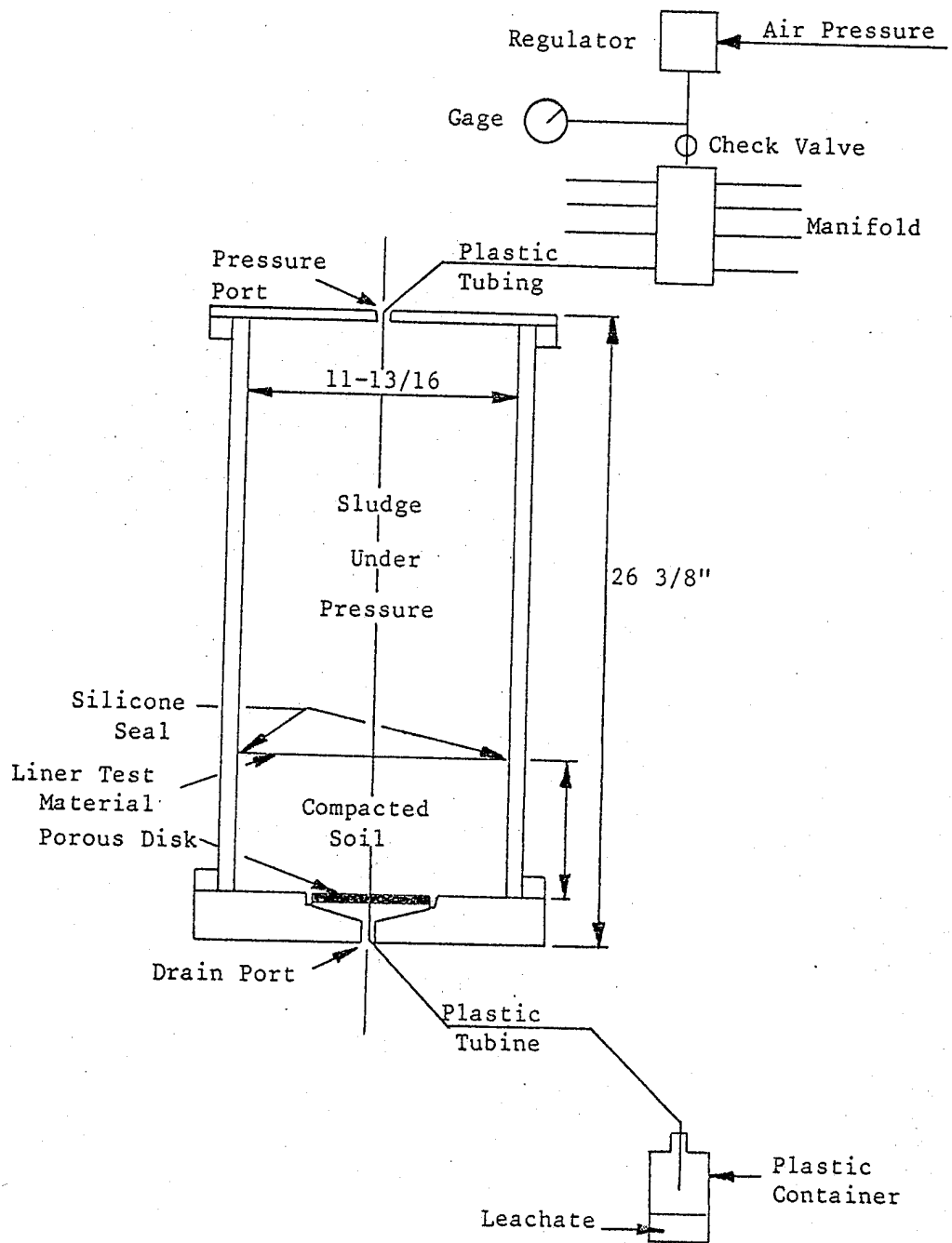

Figure 10. Schematic of a Test Cell Apparatus for Membrane Liners (Styron and Fry, 1979).

Table III. Analysis of Leachate for Liner Compatibility Tests^a (Haxo, 1979)

Test	Value
Total solids, %	3.31
Volatile solids	1.95
Nonvolatile solids	1.36
Chemical oxygen demand (COD), g/l	45.9
pH	5.05
Total volatile acids (TVA), g/l	24.33
Organic acids, g/l	
Acetic	11.25
Propionic	2.87
Isobutyric	0.81
Butyric	6.93

^aAt the end of the first year of operation when the first set of liner specimens were recovered and tested.

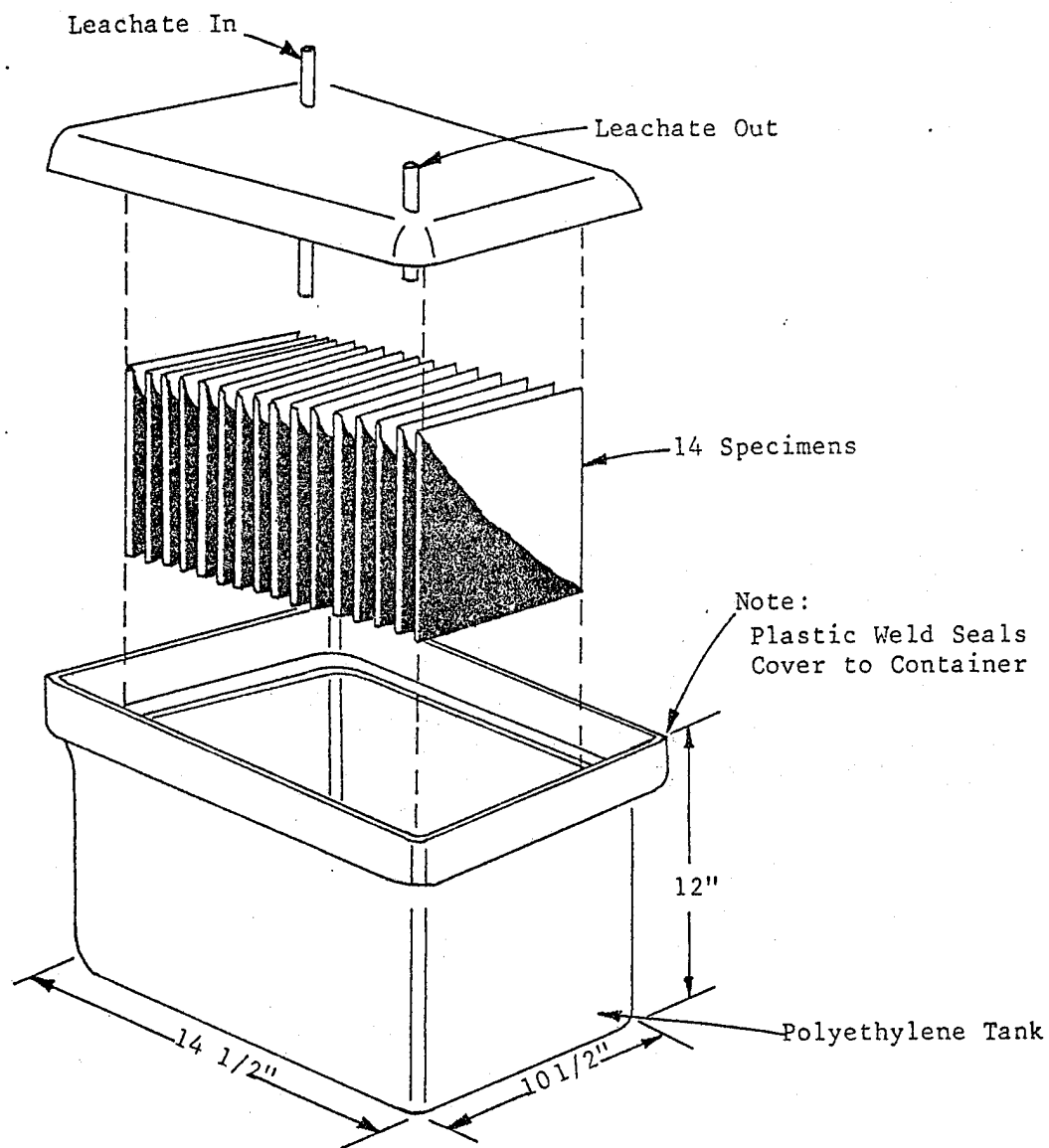

Figure 11. Individual Polyethylene Immersion Tank for Liner Compatibility Tests (Haxo, 1979).
Showing method of holding membrane specimens and the inlet and outlet for the leachate.

Table IV. Comparison of the Swelling Characteristics of Membrane Liner Materials Immersed in Water and in Leachate (Haxo, 1979).

Polymer	Liner no.	Swelling, %	
		In water for 44 weeks	In leachate for 32 weeks
Chlorosulfonated polyethylene	6	10.9	13.3
Elasticized polyolefin	36	0.0	0.1
Ethylene propylene rubber	8	1.6	6.0
Polyester elastomer	75	0.67	2.0
Polyvinyl chloride	11	0.70	2.9

Table V. Water Absorption of Selected Membrane Liner Materials at Room Temperature and at 70°C^a (Haxo, 1979).

Polymer	Water absorbed, % by weight									
	At room temperature					At 70°C				
	1 week	11 weeks	44 weeks	100 weeks	1 day	1 week	11 weeks	44 weeks	100 weeks	
Butyl rubber	0.82	3.22	4.50	6.4	2.04	4.62	17.54	53.9	103.2	
Chlorinated polyethylene	1.63	5.53	10.2	12.5	3.04	15.9	58.4	140.0	179.3	
Chlorosulfonated polyethylene	3.44	6.97	10.9	16.3	5.68	22.1	131.0	245.6	370.5	
Elasticized polyolefin	0.39	0.52	0.0	4.5	0.24	0.36	0.45	0.57	8.7	
Ethylene propylene rubber	0.50	1.30	1.56	2.25	0.42	1.11	5.55	10.8	17.8	
	1.20	1.84	1.49	2.56	0.74	1.44	4.52	11.20	17.4	
Neoprene	3.80	13.62	37.8	75.1	3.89	14.1	107.0	240.0	(b)	
	2.43	8.29	18.5	32.1	2.49	8.11	47.4	191.4	295.0	
Polyester elastomer	1.07	1.05	0.67	1.31	1.18	1.28	1.10	0.72	0.22	
Polyvinyl chloride	1.29	1.10	0.70	1.25	1.51	5.59	12.13	39.2	87.4	
	1.59	2.34	2.43	2.98	2.09	4.87	8.25	24.0	25.5 ^c	

^aASTM D570-63 specimen 1 x 2 in. in deionized water.

^bSpecimens began to disintegrate between 44th and 69th weeks.

^cSpecimens have become hard, indicating loss of plasticizer.

Table VI. Summary of the Effects of Immersion of Polymeric Membrane Liners in Leachate for 8 Months (Haxo et al., 1979).

Polymer	No. of liners in test	Absorption of leachate, %	% Original value for unexposed membrane		Change in hardness, b points	
			Tensile strength ^a	Elongation ^a S-200a		
Butyl rubber	1	1-2	90-97	104-106	85-86	0
Chlorinated polyethylene	3	8-10	80-115	64-135	84-123	-5 to -1
Chlorosulfonated polyethylene	3	13-19	82-124	97-107	47-113	-20 to -4
Elasticized polyolefin	1	0.1	86-94	91-92	102-106	0
Ethylene propylene rubber	5	1-13.5	90-91	76-138	98-220	-1 to +2
Neoprene	4	1-19	69-100	82-103	79-102	-11 to +5
Polybutylene	1	0.1	96-99	96-97	99-103	-3
Polyester elastomer	1	2.0	99-115	101-108	95-110	-4
Polyethylene	1	0.6	110-180	96-181	100-116	-7
Polyvinyl chloride	7	1-3	91-110	98-129	76-102	-2 to +1
Polyvinyl chloride + pitch	1	6.0	92	109-133	93-108 ^a	-2

aS-100 - unexposed specimen broke at 150% elongation.

a - ASTM Test D412

b - ASTM Test D2240

69.92 times those exposed at room temperature. The elasticized polyolefin and polyester elastomer had the best water absorption characteristics. Some of the liner materials disintegrated at the higher temperature.

The effects on membrane properties as a result of immersion in the leachate for 8 months are summarized in Table VI. The results of these tests show large variations in the effects of the leachate on liner materials within a polymer group. The largest intragroup variations were observed with the chlorinated polyethylene, chlorosulfonated polyethylene and neoprene. In general, the leachate had relatively mild effects on most of the liner materials. The changes in tensile strength properties appear to correlate with the amount of swelling.

Membranes were also exposed to leachate in simulated landfills. The membranes were mounted in exposure cells as shown in Figures 12 and 13, with membrane specimens buried in the sand above the primary liner for additional exposure testing. The effects of exposure of the membrane materials to leachates by this method are compared with those obtained by the immersion technique in Table VII. In general, the immersion techniques accelerated the degradation. Eight months of immersion was approximately equivalent to 12 months exposure in the simulated landfills.

Haxo and associates at Matrecon, Inc. have also tested the long term compatibility of various liner materials with hazardous wastes. The liner materials included in these tests were reinforced butyl rubber, CPE, reinforced Hypalon®, elasticized polyolefin, EPDM, reinforced neoprene, polyester elastomer and PVC. Eight types of wastes were evaluated for compatibility with these liner materials--a weed killer pesticide, nitric acid waste, hydrogen fluoride waste, spent caustic, lead waste containing organics, aromatic oil (10% organic), oil pond #104 (89% organic, 11% solids) and weed oil (20.6% organic, 78.4% aqueous). The liner materials were exposed to the wastes by immersion testing in the apparatus shown in Figure 11 and one side exposure testing in the apparatus shown in Figure 14.

The results of the immersion tests are presented in Table VIII. Several parameters were measured--weight gain, weight gain due to absorption of volatiles, non-volatile extractables, retention of S-100 modulus, and ultimate elongation. Generally, weight gain was observed with most membranes with the lowest weight gain observed in material immersed in spent caustic and the highest in aromatic oils. Several of the PVC liner materials showed weight loss indicative of leaching out of plasticizers. A significant amount of weight gain was as volatiles (at 105°C), especially in those liners immersed in aqueous solutions. Those materials immersed in oil yielded very low volatiles but high extractables. The percent of retention of S-100 modulus and elongation varied considerably with the liner material and wastes. Nitric acid destroyed the polyester material. In several instances, the elongation was reduced by 50%. CSPE and EDPM in oily wastes particularly showed low retention values.

The test cell results with the various membrane liners are presented in Table IX. All the liners absorbed material, mainly water. There was loss of extractables in the PVC and chlorinated polyethylene materials immersed in the

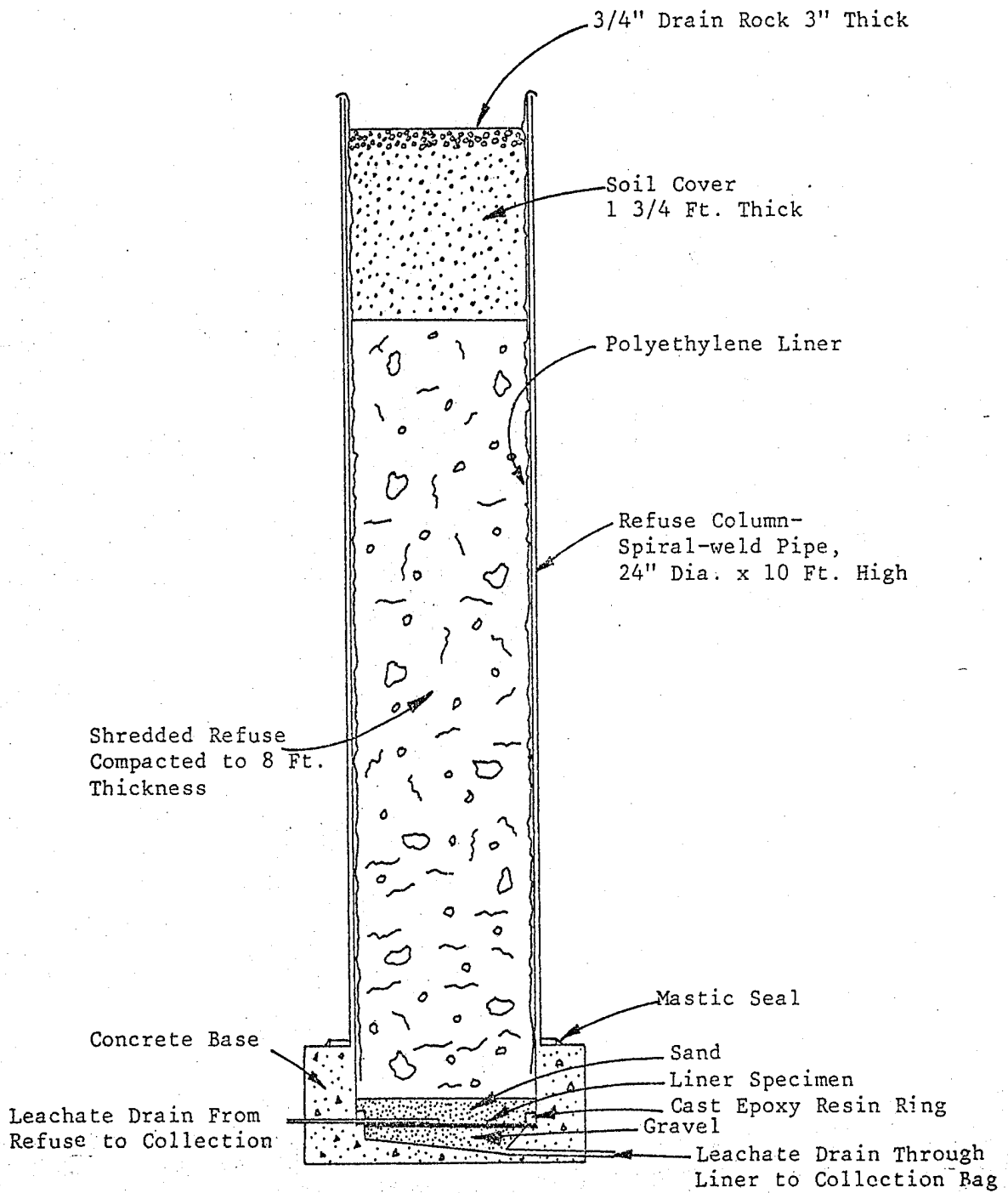

Figure 12. Schematic Drawing of Leachate Generator and Cell in Which the Liner Materials Were Exposed to Leachate Under Conditions Simulating Sanitary Landfills (Haxo, 1979).

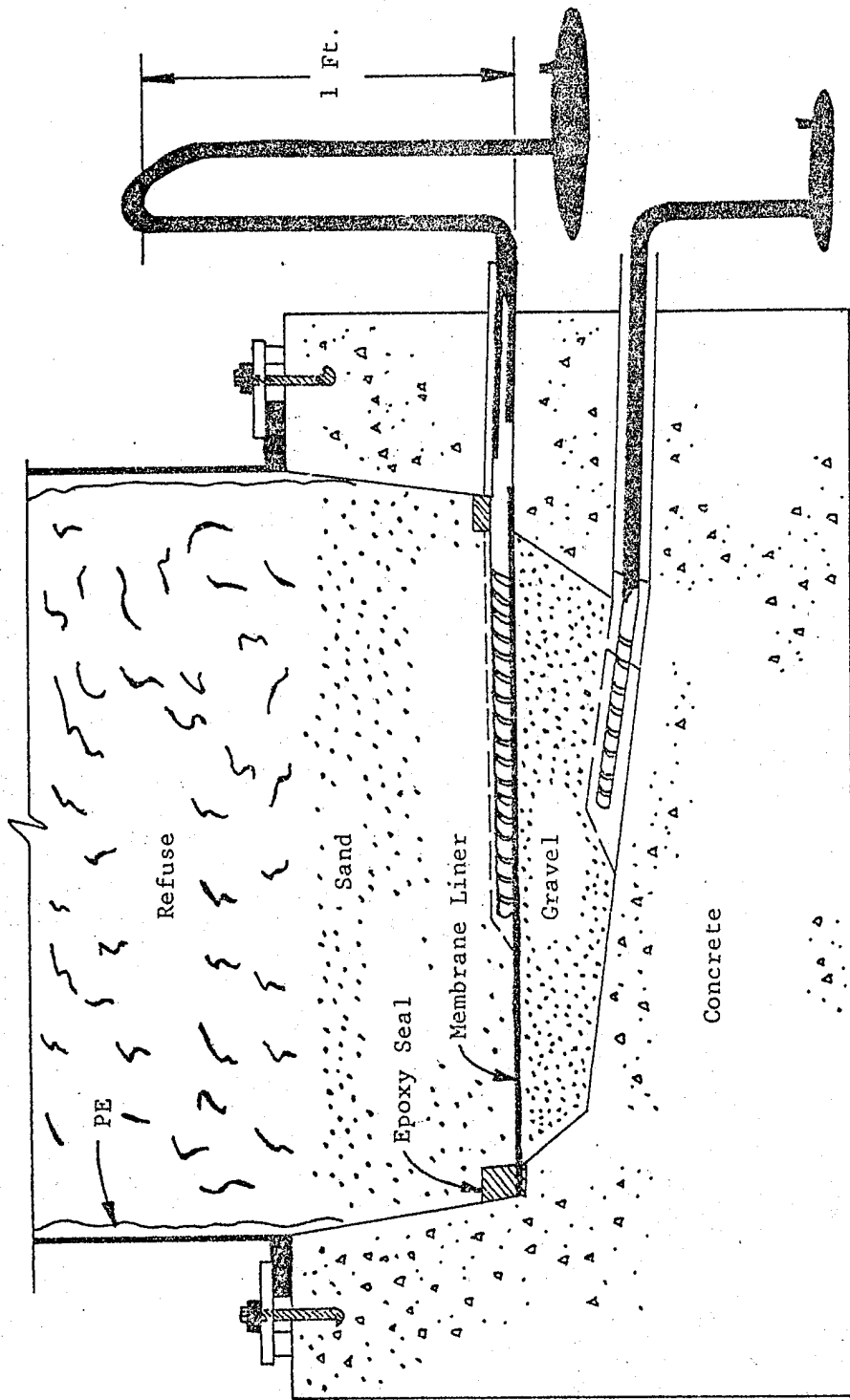

Figure 13. Detail of the Base of the Leachate Generator Showing the Refuse, the Sand Cover, and the Liner (Haxo, 1979). One foot of leachate is allowed to pond on the liner. The additional leachate is continuously collected. Leachate that seeps through or by-passes the liner because of a failure of the seal is also continuously collected.

Table VII. Swelling of Polymeric Membrane Liners by Landfill Leachate -
Leachate Content of Exposed Membrane Liner Materials in Percent (Haxo, 1979).

Polymer	Exposed in simulated landfill for 12 months ^a		Immersion in leachate for 8 and 19 months			
	Primary specimens	Buried specimens	"Volatiles" ^a		From swelling test ^b	
			8 mo.	19 mo.	8 mo.	19 mo.
Butyl rubber	2.0	1.8	1.4	2.6	1.8	3.4
Chlorinated polyethylene	6.8	9.0	7.9	14.4	8.7	15.0
Chlorosulfonated polyethylene	-	20.0	18.6	22.8	16.1	21.0
	12.8	13.6	12.1	14.9	12.0	13.9
Ethylene propylene rubber	-	5.5	2.9	3.8	5.7	7.0
	5.5	6.0	-	-	-	-
Neoprene	-	8.7	9.0	14.8	16.2	24.1
Polybutylene	-	0.3	-0.2	0.7	0.1	0.8
Polyethylene	0.02	0.3	0.0	0.2	0.6	0.7
Polyvinyl chloride	-	5.0	2.4	4.4	2.8	6.0
	3.6	3.3	2.3	4.4	3.2	3.2
	-	0.8	0.9	1.9	1.6	1.8

^aPercent leachate in swollen liner as determined by "volatiles content" at room temperature and at 105°C.

^bCalculated from the increase in weight of the immersed specimens.

- Not reported

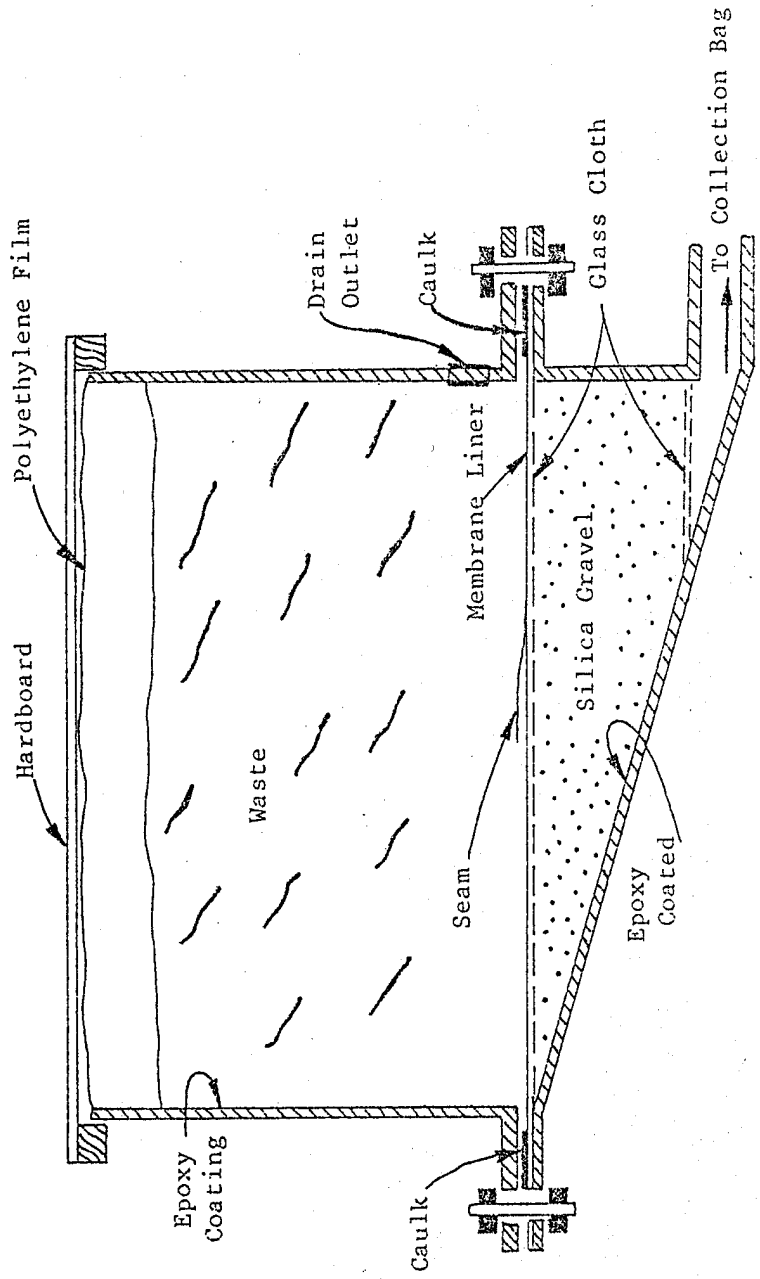

Figure 14. Schematic Drawing of Exposure Cell for Membrane Liners (Haxo et al., 1977). Exposed area of liner is 10 in. by 15 in. and depth of the waste is 1 foot.

Table VIII. Effects of Immersion of Liner Materials in Hazardous Wastes (adapted from Haxo, 1980).

Compound	Waste/Immersion Time, days	Absorption of Waste, Wt %	Volatiles Content, % wt. loss	Extractables after Devolatilization, wt. %	S-100 Modulus % of Unexposed	Ultimate Elongation, % Retention
Vulcanized Butyl (Thermoplastic)	Water/1113	10.9@20°; 4@70°	0.28(U)	11.5(U)	310 psi (U)	445%(U)
	Pesticide/807	1.6	3.0	-	88	109
	HNO ₃ /751	3.8	3.8	11.1	72	110
	HF/761	3.7	2.9	10.6	93	93
	Spent Caustic/780	0.8	6.9	10.9	91	94
	Lead/786	28.7	15.3	17.1	57	111
	Oil #104/752	103.9	9.8	40.3	45	54
	Aromatic Oil/761	31.2	3.3	27.2	56	102
	Weed Oil/809	64.2	19.2	15.2	39	71
	Water/1113	16.9@20°; 179.9@70°	0.00(U)	9.1(U)	900 psi (U)	405%(U)
	Pesticide/807	12.7	8.6	-	102	94
	HNO ₃ /751	19.9	20.4	12.0	69	88
	HF/761	12.9	8.1	10.2	116	81
	Spent Caustic/780	1.1	1.6	9.2	126	87
Lead/786	118.9	42.2	16.6	18	92	
Oil #104/752	36.9	5.2	19.2	45	92	
Aromatic Oil/761	226.4	deteriorated	deteriorated	deteriorated	deteriorated	deteriorated
Weed Oil/809	ND	ND	ND	ND	ND	ND
Fabric Reinforced CSPE (Thermoplastic)	Water/1113	20.8@20°; 438.2@70°	0.29(U)	3.8(U)	945 psi (U)	235%(U)
	Pesticide/807	17.3	10.8	-	124	82
	HNO ₃ /751	10.0	10.4	3.8	67	126
	HF/761	9.0	7.6	3.8	126	93
	Spent Caustic/780	4.3	4.2	3.8	170	72
	Lead/786	120.7	3.3	4.6	88	65
	Oil #104/752	49.5	20.2	16.3	88	79
	Aromatic Oil/761	105.2	6.1	45.4	73	77
	Weed Oil/809	368.4	50.7	19.0	deteriorated	deteriorated
	Water/1113	-	0.42(U)	4.1(U)	880 psi (U)	280%(U)
	Pesticide/807	15.7	7.9	-	122	79
	HNO ₃ /751	10.9	9.1	4.0	71	104
	HF/761	7.7	7.1	3.6	113	94
	Spent Caustic/780	3.3	3.6	4.2	167	74
Lead/786	116.2	1.1	3.7	93	60	
Oil #104/752	55.0	10.0	15.9	89	68	
Aromatic Oil/761	110.5	4.8	59.8	85	52	
Weed Oil/809	347.5	39.7	16.1	deteriorated	deteriorated	

Table VIII. Continued

		0.9@20°; -4.2@70°	0.15(U)	5.5(U)	875 psi (U)	665%(U)
Elasticized Polyolefin (Thermoplastic)	Water/1113		0.45	-	122	95
	Pesticide/807	0.5	7.2	6.2	99	97
	HNO ₃ /751	7.6	1.3	5.1	112	96
	HF/761	1.1	0.6	5.5	116	91
	Spent Caustic/780	0.6	9.5	6.9	79	84
	Lead/786	17.0	3.1	17.8	80	88
	Oil #104/752	28.9	1.5	23.3	76	90
	Aromatic Oil/761	29.4	16.4	8.1	57	78
	Weed Oil/809	38.1	0.31(U)	18.2(U)	810 psi (U)	255%(U)
			4.5	4.89	94	128
			4.2	3.1	84	135
			3.1	2.8	109	109
	Fabric Reinforced. EPDM (Thermoplastic)	Spent Caustic/780	1.6	2.2	17.6	84
Lead/786		24.8	13.9	17.1	100	157
Oil #104/752		26.5	8.5	18.0	44	145
Aromatic Oil/761		19.8	4.4	21.2	54	157
Weed Oil/809		84.4	24.1	22.2	58	145
				27.2	58	155
				18.7	deteriorated	deteriorated
				23.6(U)	340 psi (U)	490%(U)
				15.6	90	101
				22.6	58	97
				23.6	100	86
				1.2	100	106
				18.5	73	98
			11.8	58	52	
			4.2	60	100	
			33.4	67	56	
Vulcanized EPDM	Water/1113	3.5@20°; 12.6@70°	0.34(U)	21.5(U)	560 psi (U)	415%(U)
	Pesticide/807	20.4	15.6	-	77	101
	HNO ₃ /751	50.9	22.6	25.4	90	87
	HF/761	23.9	23.6	22.4	58	86
	Spent Caustic/780	1.3	1.2	22.9	100	106
	Lead/786	34.7	18.5	30.0	100	86
	Oil #104/752	84.7	11.8	43.5	73	98
	Aromatic Oil/761	34.2	4.2	38.4	58	52
	Weed Oil/809	76.2	33.4	25.4	60	100
				21.5(U)	67	56
				0.27(U)	560 psi (U)	415%(U)
				7.26	77	101
	Vulcanized Neoprene	Water/1113	3.9@20°; 21.1@70°	0.27(U)	21.5(U)	560 psi (U)
Pesticide/807		11.4	13.7	19.2	77	101
HNO ₃ /751		17.4	10.5	19.6	63	87
HF/761		12.0	2.9	20.8	104	68
Spent Caustic/780		1.5	23.6	19.2	121	83
Lead/786		59.1	6.3	23.9	38	91
Oil #104/752		26.3	3.9	58.5	70	77
Aromatic Oil/761		142.6	28.9	7.6	40	62
Weed Oil/809		89.3	28.9	7.6	27	65

Table VIII. Continued

Polyester (Thermoplastic)	Water/1113	1.6@20°; -0.8@70°	0.26(U)	2.7(U)	2585 psi (U)	575%(U)
	Pesticide/807	4.2	1.75	-	111	89
	HNO ₃ /751	6.4	28.0	10.8	-	1
	HF/761	2.0	3.8	3.3	117	90
	Spent Caustic/780	1.5	1.3	2.7	105	84
	Lead/786	7.4	6.1	3.3	92	101
	Oil #104/752	8.5	2.1	6.5	95	96
	Aromatic Oil/761	16.6	3.4	6.6	76	87
	Weed Oil/809	14.7	9.5	6.1	78	96
		1.7@20°; 126.3@70°	0.15(U)	33.9(U)	1280 psi (U)	350%(U)
PVC (Thermoplastic)	Water/1113	5.1	30.9	35.4	118	103
	Pesticide/807	22.1	22.6	32.3	104	86
	HNO ₃ /751	18.1	18.3	32.7	106	86
	HF/761	0.4	0.6	33.9	121	97
	Spent Caustic/780	-1.5	16.1	17.3	102	104
	Lead/786	-10.4	2.7	18.0	207	85
	Oil #104/752	18.5	3.6	40.6	131	76
	Aromatic Oil/761	15.3	17.1	21.1	52	107
	Weed Oil/809					
		4.5@20°; 26.2@70°	0.26(U)	35.9(U)	960 psi (U)	385%(U)
PVC (Thermoplastic)	Water/1113	1.0	40.1	34.9	135	96
	Pesticide/807	-6.1	10.6	23.3	262	65
	HNO ₃ /751	0.9	3.0	34.0	129	93
	HF/761	-0.9	1.5	35.8	128	86
	Spent Caustic/780	7.4	12.7	27.9	91	101
	Lead/786	-0.5	3.3	28.0	152	96
	Oil #104/752	28.9	4.6	47.6	112	78
	Aromatic Oil/761	24.7	16.1	30.1	47	96
	Weed Oil/809					
		0.17(U)	33.9(U)	1735 psi (U)	330%(U)	
PVC (Thermoplastic)	Pesticide/807	1.6	3.51	31.7	100	98
	HNO ₃ /751	28.2	23.2	33.2	70	86
	HF/761	14.3	13.1	33.1	83	89
	Spent Caustic/780	1.1	1.2	32.5	99	100
	Lead/786	-5.2	11.5	17.9	97	105
	Oil #104/752	-9.8	4.3	14.8	172	78
	Aromatic Oil/761	14.1	3.5	38.5	123	82
	Weed Oil/809	25.2	24.1	20.1	45	107

Table IX. Effects of Hazardous Wastes on Liners Exposed in Test Cells (adapted from Haxo, 1980)

Compound	Waste Immersion Time/days	Volatiles Content % wt. loss	Extractables after Devolatilization Wt. %	S-100 Modulus % of Unexposed	Ultimate Elongation, % Retention
Vulcanized Butyl		0.29(u)			70%(U)
	Pesticide/1260	4.8	7.6		77
	HNO ₃ /1220	11.5	8.7		419
	Spent Caustic/1250 Lead/1340	1.4 3.5	7.9 7.9		142 108
CPE (Thermo-plastic)		0.00(U)		900 psi (U)	405%(U)
	Pesticide/1260	7.9	9.4	114	90
	HNO ₃ /1220	13.2	10.6	84	88
	Spent Caustic/1250 Lead/1340	2.8 19.2	9.1 7.2	132 72	115 84
CSPE (Thermo-plastic)		0.29(U)		645 psi (U)	235%(U)
	Pesticide/1260	9.7	5.4	118	88
	HNO ₃ /1220	7.2	4.6	112	83
	Spent Caustic/1250 Lead/1340	5.8 11.4	3.8 6.0	199 118	68 81
Elasticized Polyolefin (Thermo-plastic)		0.15(U)		875 psi (U)	665%(U)
	Pesticide/1260	SE	SE	SE	SE
	HNO ₃ /1220	5.3	7.1	103	96
	Spent Caustic/1250 Lead/1340	SE 1.5	SE 8.1	SE 110	SE 106
Vulcanized EPDM		0.50(U)		360 psi (U)	103%(U)
	Pesticide/1260	6.3	25.2	88	79
	HNO ₃ /1150	12.0	22.8	70	95
	Spent Caustic/1250 Lead/1340	1.3 5.3	24.0 26.0	109 80	106 360

Table XI. Continued.

Vulcanized Neoprene	Pesticide/1260	0.45(U)	16.1	460 psi (U)	320%(U)
	HNO ₃ /1220	13.6	-	54	84
	Spent Caustic/1250	-	13.7	96	95
	Lead/1340	5.7	12.7	62	75
Polyester (Thermo- plastic)	Pesticide/1260	0.26(U)	5.8	2585 psi (U)	575%(U)
	HNO ₃ /1220	2.9	13.5	96	87
	Spent Caustic/1250	7.4	3.3	-	<1
	Lead/1340	0.9	5.4	110	87
PVC (Thermo- plastic)	Pesticide/1260	1.7		88	90
	HNO ₃ /1220	0.26(U)	33.4	960 psi (U)	385%(U)
	Spent Caustic/1250	3.6	SE	144	93
	Lead/1340	1.8	35.6	170	95
		4.4	22.5	107	106

lead wastes. Loss of elongation was most prominent in the polyester elastomer exposed to nitric acid. CSPE also showed a high loss of elongation. Increase in stiffness as measured by the S-100 modulus was observed with the neoprene liner exposed to the lead and pesticide wastes, by PVC exposed to pesticide and caustic wastes and by CSPE exposed to caustic wastes (Haxo, 1980).

Haxo (1980) also tested the effects of simultaneous exposure of the membrane materials to weather and the wastes. Small tubs were lined with the different materials, filled with the various wastes and placed on the building roof. The results of these tests were not available although dry exposure to weather for 745 days showed loss of weight. Some specimens also lost elongation.

Haxo (1980) also developed a permeability test to determine the effects of the wastes on the permeability of the membrane. In this test, heat sealable membranes are formed into a bag, the waste placed inside and the bag sealed. This bag is then submerged in deionized water as shown in Figure 15. The bag is weighed periodically and the pH and conductance of the deionized water measured to determine the permeability of the membrane. The results of the bag tests are presented in Table X. The elasticized polyolefin appears to be the least permeable of the liner materials tested while the chlorinated polyethylene was the most permeable.

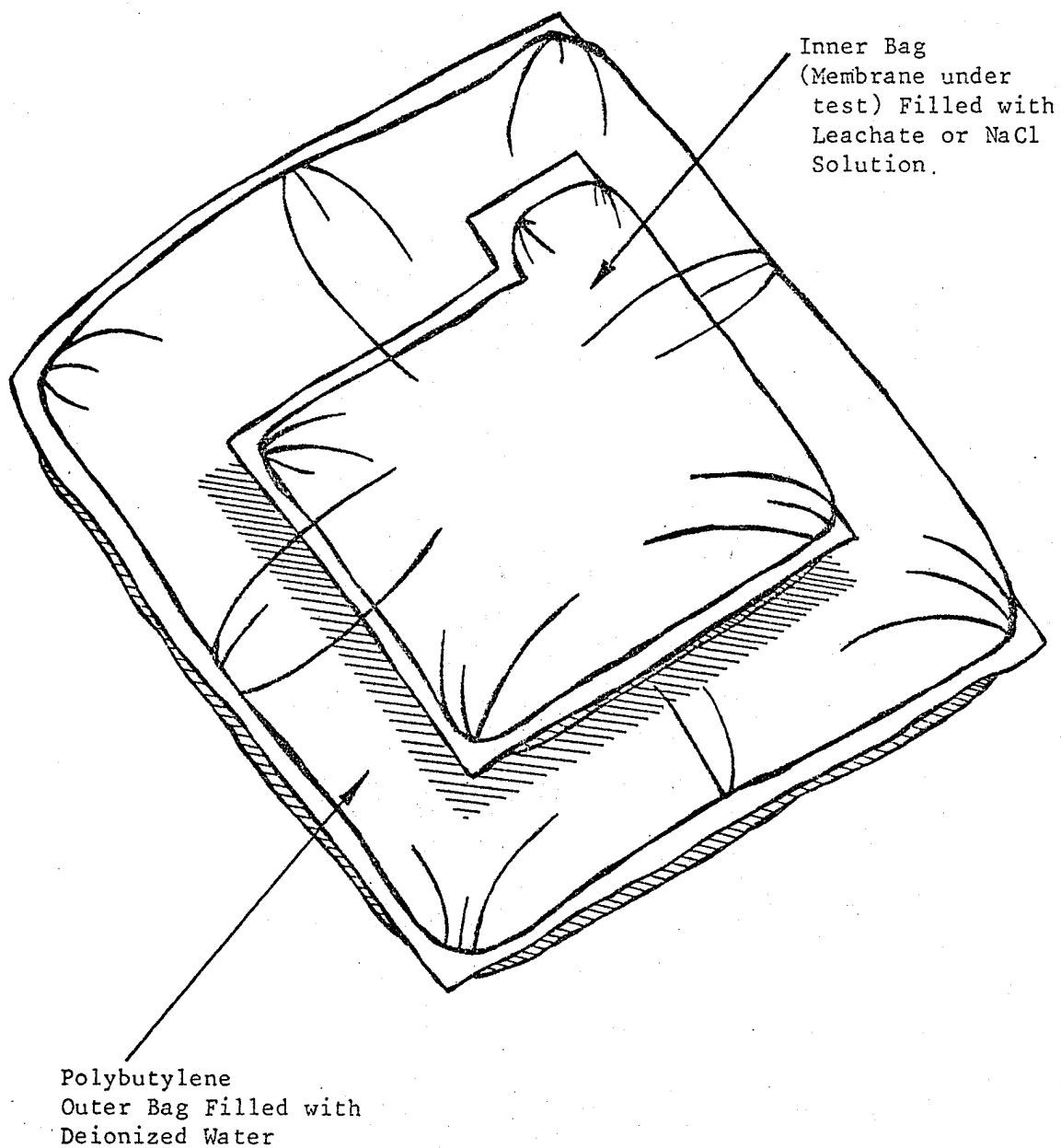

Figure 15. Schematic of Osmosis Bag Assembly (Haxo, 1979).

Table X. Tests of Membrane Liner Bags Filled With Leachate - Permeability of Membranes to Water and to Ions Due to Osmosis (Haxo, 1979).

Polymer	Liner No.	Original values			Values at 70 days			Values at 500 days		
		pH ^a	Ion Conc., ^b ppm	Water permeability, ^c g/m/s x 10 ⁻⁷	pH ^a	Ion conc., ^b ppm	Water permeability, ^c g/m/s x 10 ⁻⁷	pH ^a	Ion conc., ^b ppm	Water permeability, ^c g/m/s x 10 ⁻⁷
Chlorinated polyethylene	77	5.7	3	5.8	16	49.6	6.5	72	19.6	
Elasticized polyolefin	36	5.1	2	5.0	5	(d)	4.5	10	0.9	
Polyester elastomer	75	4.0	10	3.5	41	17.1	6.4	28	12.2	
Polyvinyl chloride	11	5.8	3	4.4	18	12.1	6.0	18	4.6	
Polyvinyl chloride	17	5.0	7	2.9	190	9.7	2.8	190	5.7	
Polyvinyl chloride	59	5.7	3	3.8	35	28.6	6.3	9	5.0	
Blank	--	5.5	1	5.7	1	--	4.3	6	--	

^apH and conductivity of deionized water in the outer bag.

^bIon concentration of deionized water in outer bag calculated as NaCl from electrical conductivity measurements.

^cWater permeability of liner calculated from weight gain of the inner bag containing leachate.

^dLost weight.

D. Past Experience With Membrane Liners

Hypalon® and PVC are the most widely used flexible membrane liners. Hypalon® has been successful in lining holding pits and ponds of acidic mining wastes (American City and County, 1977). There have also been cases where Hypalon® has been in service for 10 years in ponds containing salts including sulfates and chlorides. One company successfully used a cover of 2 cm of sand over their Hypalon® liner to prevent attack by heavy hydrocarbons (Gupta and Miles, 1979).

A pond was constructed in Antioch, California, for the Imperial West Chemical Company for conversion of pickle liquor waste from U.S. Steel into a ferric chloride solution. It was designed in a kidney shape to make optimum use of available land. The slope of the walls ranged from 3:1 to 2:1. A 0.75 mm Hypalon® liner was chosen because of its overall resistance to sun, weathering, oil, acids, and physical abuse. Prior to storage in the pond, the pickle liquor is neutralized to less than 1% free acid (Pelloquin, 1972). The pond is still doing well (Middlebrooks *et al.*, 1978), and it appears that the liner will outlast its 20 year warranty (Dallaire, 1975).

Syracuse, New York, relined their 40-year-old Westcott reservoir with nylon reinforced Hypalon®. The neighboring town of Solvay had used a 3-ply 0.76 mm Hypalon® liner for their reservoir which had worked well and had adapted to drastic weather changes. Since the Syracuse reservoir was larger, they installed a 5-ply 1.14 mm liner. The reservoir had side slopes of 2:1 and had originally been lined with gunite and granite blocks, whose sharp edges had to be taken care of prior to installation of the membrane. It is hoped that the lined reservoir will last for another 40 years of service.

A company in Mont Belvieu, Texas, installed a nylon reinforced Hypalon® liner for brine storage. For a similar brine storage pond in Freeport, Texas, Hypalon® was chosen because it could stand up to trace hydrocarbons that might be in solution, is resistant to UV radiation, is resistant to brine, and had a 20-year warranty (Dallaire, 1975).

Buckeye Cellulose of Perry, Florida, had a 0.76 mm Hypalon® liner installed in 1973. It is used to contain standard paper mill effluent, which consists of sulfates, sulfites, chlorides, and wood fibers, but no aromatic hydrocarbons. The pH of the effluent is around 7.2 and the temperature is 32 to 35°C. The temperature of Perry in the summer averages 29 to 35°C and the winter temperature is 4 to 8°C with an annual rainfall between 178 and 203 cm and a great deal of sunshine. The liner was the largest installed at the time. For the first five years of operation, no problems were encountered. Then a change in the plant operation introduced a sufficient amount of hydrocarbons into the pond to cause attack on the liner. There was some damage, but the operations were changed again to eliminate the hydrocarbon problem. Since the hydrocarbon problem was corrected, the liner has performed well (Karnes, 1980).

PVC has been used successfully in many brine ponds and those containing large amounts of chlorides, sulfates, carbonates and silicates. Where organic

solvents were involved, there were attacks on the liner. One company solved the problem of organic fractions by placing a layer of soil over the liner. There have been no problems with this liner so far, and the life expectancy of the liner is 20 years. There have been cases of failure due to exposure to the sun, which causes PVC to become brittle, and also when PVC and CPE were used together and exposed to heat, which caused mutual destruction (Gupta and Miles, 1979).

A PVC liner was used in a demonstration landfill in Crawford County, Ohio in 1971. In 1977, the liner was retrieved and found to be in excellent condition. There were no data on the original liner specifications or on what was put in the fill, but the leachate was mild compared to a standard landfill (Haxo et al., 1979).

Pollution Abatement Services of Oswego, New York, installed a PVC liner to contain commercial solvents, waste oils, acids, bases, and organic liquids mixed with water. An unexpected concentrated load of aromatic solvents destroyed the liner, which was then replaced with a Dupont 3110TM elasticized polyolefin liner. The liner is holding up well, but the operators are now carefully monitoring what goes into the lagoon, allowing not more than 3% organic liquids (Dallaire, 1975).

Two PVC lined evaporation ponds for power plant blowdown containing high dissolved salts were constructed in the western United States. The small pond used 0.51 mm PVC covered with sand to prevent exposure to the sun, and a layer of gravel on the slopes to prevent wave action from the rising and falling levels of liquid. The larger pond used a 0.25 mm instead of a 0.51 mm liner since a layer of sand was not being used and heavy machinery would not be putting a strain on the liner during installation. To avoid damage from UV exposure, 30 cm of water remains in the pond at all times and sand and rip-rap protect the slopes (Dallaire, 1975).

Texasgulf, Inc. in Moab, Utah, constructed a series of 23 brine solar evaporation ponds lined with 0.51 mm PVC. The total installation was 181 ha (Dallaire, 1975).

A landfill operation in Brookhaven, Long Island was begun in 1975 using a PVC liner to prevent contamination of the ground water which is Brookhaven's drinking water supply. The landfill is scheduled to reach 76 m above ground level and will eventually become a ski slope (Dallaire, 1975).

The Forest Service of Oregon's Umpqua National Forest wanted to construct self-contained water and sanitation facilities for the increasing number of tourists visiting the park. The result was a series of 4 PVC lined oxidation lagoons called the Diamond Lake Water and Sanitation Project. Construction was completed in 1970 (Contractors and Engineers Magazine, 1971). The liners were 0.25 mm thick and covered with pumice and crushed rock. There has been no seepage from the liners (Middlebrooks et al., 1978).

A pond containing mine and mill wastes consisting largely of copper chloride was lined with polyester reinforced CPE. After three years, there was no indication of leaks (Gupta and Miles, 1979).

Kerr McGee has had a great deal of experience with liner materials. They had numerous failures with unreinforced CPE in lagoons located in the Colorado desert. The liners would deteriorate only in the summer and would last from three to six summers before total failure. The lagoons stored various chemicals. Some contained oxidizers such as chlorates and perchlorates of sodium, potassium and ammonium; others contained either acids or alkalies. All liners reacted similarly and independent of the wastes. The breakdown was attributed to UV exposure and high temperature. The liners were black and absorbed heat, so when the air temperature was 46 to 49°C, the liner temperature reached 65 to 82°C. Some of the liners have been replaced with butyl EPDM and have lasted over five years. The butyl EPDM liners lose their carbon black but retain pliability (Rodgers, 1980).

Kerr McGee has found butyl EPDM liner material to be satisfactory liner for solar evaporation ponds. Liner failures have also been reported in other ponds containing "standard industrial effluent" which were subject to the sun and high temperatures of the desert. One of these ponds had a PVC liner with no cover, the other had PVC on the bottom and reinforced Hypalon® CP on the berm. A desert pond liner that is currently being evaluated consists of PVC on the bottom and reinforced Hypalon® and reinforced CBE on the berms. However, difficulty has been experienced with wind and wave action on this liner in large lagoons (Surtees, 1980). Kerr McGee has compiled a report summarizing ten years of experience with liners, however, it is not available to the public.

Polyethylene has been used since the 1960's for applications from lining lagoons for treatment of chemical wastes to holding sewage and wastewater (Middlebrooks et al., 1978). Polypropylene, in addition to being used as a membrane itself, has also been used as a fiber base for asphalt membranes (Baker, 1970). Dupont 3110™ elasticized polyolefin has been used for water containment in two projects in New South Wales. In addition to remaining impermeable, the liner material survived possible wind damage during installation (Water and Wastes Engineering, 1977).

IV. PREDICTIVE MODELS OF LINER FAILURE

A. Bentonite Liners

Bentonite forms an impermeable barrier to water by swelling of the dry clay particles when hydrated. If the liner remains in contact with a supply of pure fresh water, the clay will remain in its most swollen state to provide maximum impermeability. There are two mechanisms by which a bentonite liner could fail: the liner could be mechanically disturbed, or the swelling of the bentonite could be reduced by some contaminant in the lagoon or by dehydration. Minor disturbances of the bentonite tend to be self-healing because of the flow properties of the clay. Accidental major disturbances of the liner are unlikely except in the case of an earthquake. Since the waste lagoons are intended to be kept full, the possibility of liner failure by dehydration will not be considered. This leaves the problem of failure of the bentonite liner by a reduction in swelling. When some material in the waste lagoon causes shrinkage of the bentonite, volume which was occupied by the hydrated clay becomes available for water transport, and the liner becomes more permeable.

While some organic materials are known to interfere with bentonite swelling, there is no model currently available to predict which organics will be most likely to disrupt the hydrated bentonite. For the case of salts, however, extensive models based on the electrical potential of ions dispersed between clay particles can be used to predict the degree of swelling for a particular clay in contact with a solution of known concentration. One such model developed by Langmuir (1938) is presented here.

Individual clay particles are visualized as negatively charged platelets with layers of water and positively charged counterions dispersed between them. Referring back to Figure 2, it can be seen that the clay structure acquires a net negative charge by substitution of Al^{3+} for Si^{4+} in the outer layers of the particle and by the substitution of Fe^{2+} or Mg^{2+} for Al^{3+} or Fe^{3+} in the center of the particle (Borchardt, 1977). Associated cations surround the clay particle to preserve electrical neutrality. Interactions between these charged particles are the result of van der Waals attractive forces, Born repulsive forces (resistance to interpenetration of crystal structures), specific adsorption repulsive forces (resistance to penetration of adsorbed molecules on the surface or in the hydration shells of the free cations), and electric double layer repulsive forces (repulsion between cations associated with adjoining clay particles) (Gast, 1977). Since the Born and specific adsorption forces are important only at very short ranges, the van der Waals and double layer forces dominate at interparticle distances greater than 30\AA .

The electric double layer theory combines the effects of van der Waals forces and repulsive forces between the diffuse layers of cations associated with each clay particle by assuming that the electrochemical potential of an ion in the clay-solution system is constant regardless of position when the system is at equilibrium and that the clay platelet can be modeled as an infinite, flat, negatively charged plate. These assumptions are expressed in the following equations.

$$\bar{\mu}(x) = \mu(x) + z\varepsilon\psi(x)$$

$$= \mu(x=\infty) + z\varepsilon\psi(x=\infty) \quad (\text{Gast, 1977})$$

x: distance of an ion from the midpoint between particles

$\bar{\mu}$: electrochemical potential

μ : chemical potential

z: valence of the ion

ε : charge on an electron, 4.8×10^{-10} esu/electron

ψ : electrical potential, esu

$$\frac{d\psi}{dx} = \frac{4\pi\Gamma_s}{D}$$

Γ_s : charge density of the negative surface, esu/cm²

D: dielectric constant of the bulk solution

Defining a new variable Y, the scaled electrical potential, the above equations can be combined to give

$$\frac{dY}{dx} = K \sqrt{2 \cosh Y - 2 \cosh Y_b} \quad (\text{Kemper and Quirk, 1970})$$

$$Y = z\varepsilon\psi/kT$$

$$K = \sqrt{8\pi\varepsilon^2 N z^2 C_0 / (1000 DkT)}$$

k: Boltzmann's constant, 1.38×10^{-23} J/°K

T: absolute temperature, °K

N: Avogadro's number, 6.02×10^{23}

C_0 : equilibrium solution concentration, mol/l

Y_b : value of Y at the midpoint between adjacent clay atoms

This equation was evaluated at the surface of the particle by Kemper and Quirk (1970) to give

$$\cosh Y_s = \frac{1000 \pi \Gamma_s^2}{DNkTC_0} - \cosh Y_b$$

Their results are plotted in Figure 16, which relates $\frac{\Gamma_s}{\sqrt{C_0}}$, $zx\sqrt{C_0}$, Y, and Y_b .

According to McNeal (1970), the repulsive pressure, P, between adjacent montmorillonite layers may be due to an osmotic pressure difference between the interlayer and external solutions, in which case

$$P = nRT C_0 (\cosh Y_b - 1)$$

P: confined swelling pressure in excess of atmospheric pressure, atm

n: moles ions/mole dissolved salts

R: gas constant, 1 atm/mol·°K

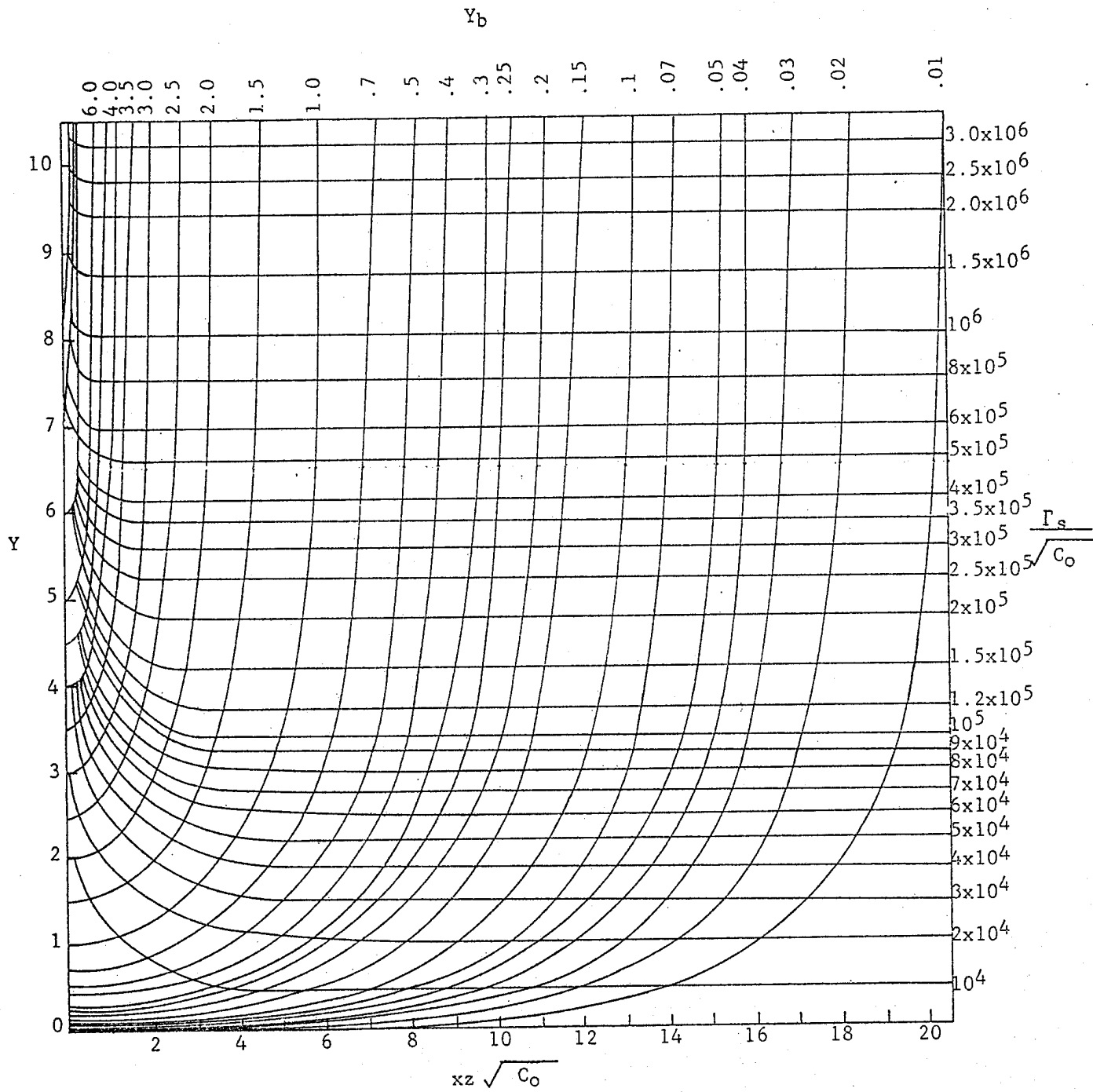

Figure 16. Scaled Potential as a Function of Solution Concentration, Distance From, and Charge Density of Mineral Surfaces (Kemper and Quirk, 1970).

Similar equations for swelling pressure are given by Kemper and Quirk (1970) and by Low and Margheim (1979).

With this information and the surface charge density for a particular bentonite, the expected shrinkage for fully hydrated bentonite in contact with any known mixture of salts under a known hydrostatic head can be calculated in the following manner. For convenience, the assumptions of Quirk and Kemper (1970) concerning the dielectric constant and the solution temperature will be used so that calculations can be made directly from Figure 16. These assumptions are:

$$D = 78$$
$$T = 298^{\circ}\text{K}$$

If we also assume pure montmorillonite, the surface charge density calculated by Gast (1977) is

$$\Gamma_s = 3.44 \times 10^4 \text{ esu/cm}^2$$

For an actual clay sample, this surface charge density should be determined experimentally.

It is now possible to predict the degree of swelling or shrinkage of a particular bentonite when the ionic concentration of an external solution is changed. Figure 17 is a graph of the half-distance between particles, b , in angstroms vs. the concentration of sodium chloride solution in contact with the bentonite described above at several different applied pressures. Note that these applied pressures are in addition to normal atmospheric pressure. Figure 17 was generated by calculations based on the previous development.

As an example, consider the case of a pure montmorillonite lagoon liner under 2 m of water ($P = 0.2 \text{ atm}$) which was hydrated with water containing 0.001 mol/l NaCl. If the lagoon is filled with 0.05 mol/l NaCl, the degree of shrinkage can be calculated from Figure 17 as follows:

$$C_o = .001 \text{ mol/l} \quad b = 95\text{\AA}$$

$$C_o = 0.05 \text{ mol/l} \quad b = 37\text{\AA}$$

If we assume that the platelets are oriented along a single axis, then the total volume is proportional to b and

$$\% \text{ shrinkage} = \frac{95-37}{95} = 61\%$$

This much shrinkage would severely reduce the effectiveness of the liner to the point where it would be unacceptable.

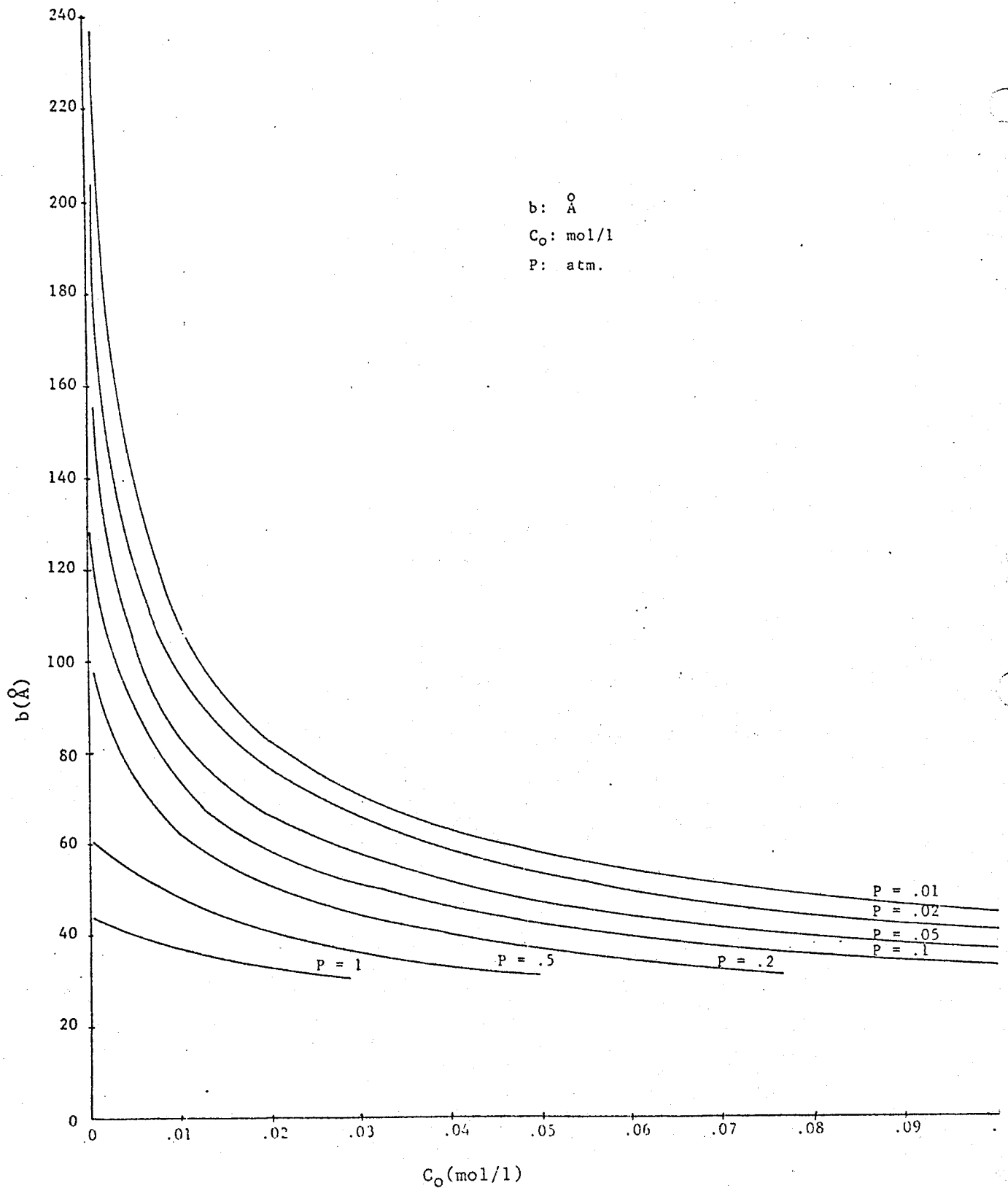

Figure 17. Interparticle Distances as a Function of NaCl Concentration at Several Applied Pressures.

While the model to this point has dealt exclusively with inorganic salts, it can be extended without difficulty to include polar organics in much the same fashion as inorganic salts. In addition, effects of both polar and nonpolar organics on the dielectric constant should be considered.

In general, the double layer model agrees reasonably well with experimental evidence, as can be seen in Figure 18. Deviations from predicted values result from a number of assumptions which are not strictly true:

- Approaching cations can be treated as point charges throughout the system.
- Bentonite platelets can be modelled as infinite flat plates with uniform charge distributions.
- Bentonite platelets are aligned preferentially so that swelling occurs in only one dimension.

Since the model is based on thermodynamics rather than kinetics, there is no indication of the rapidity of liner deterioration. Despite these drawbacks of the model, a reasonably good estimate of the total reduction in swelling (and hence the increase in permeability) can be calculated for a bentonite liner exposed to a particular waste solution. Qualitatively, the model predicts greater interparticle distances and, therefore, greater swelling for low ionic concentrations and for low valence ions.

B. Synthetic Membrane Liners

Unlike bentonite and other clay materials which have been studied and modelled extensively, literature on synthetic membrane liners presents nothing but empirical evidence for particular membrane polymers. The most serious problems for membrane liners, as discussed in Section III, are loss of desirable mechanical properties due to swelling of the polymer and/or loss of plasticizer. These rates and the extents to which these processes occur are influenced by a number of factors including diffusion rates of water and waste materials into the polymer, diffusion rate of plasticizers out of the polymer, and reactivity of the plasticizers and polymers with materials in the waste lagoon. While each of these processes could be modelled for strictly controlled conditions and experimentally determined rate constants for a particular polymer/waste combination, there is little hope for a single model to account for all these processes simultaneously.

In order to adequately predict synthetic membrane liner compatibility for a particular waste, long-term laboratory tests are required. Tests and properties recommended by Haxo (1980) as being the most useful for predicting liner compatibility are:

- The measurement of swelling of the membrane materials in the wastes or in the leachate of the wastes.

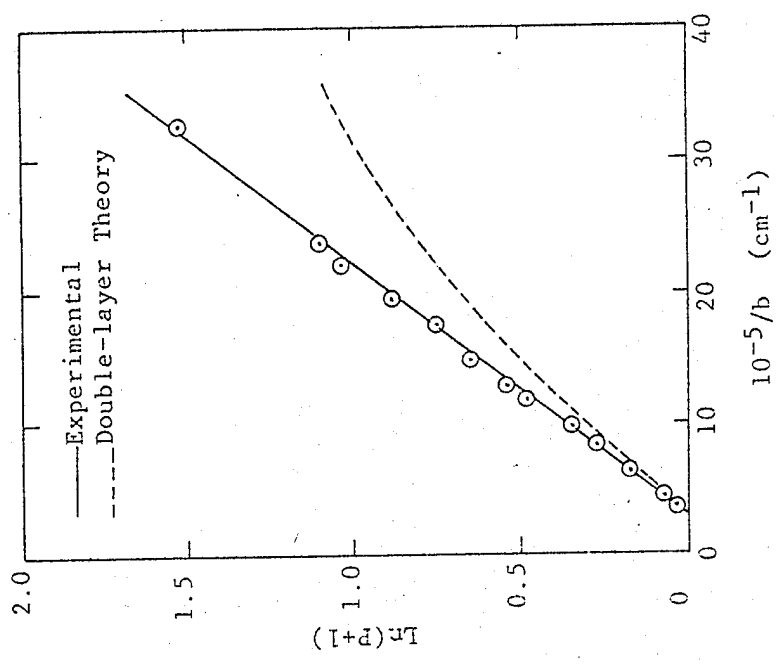

Belle-Fourche montmorillonite

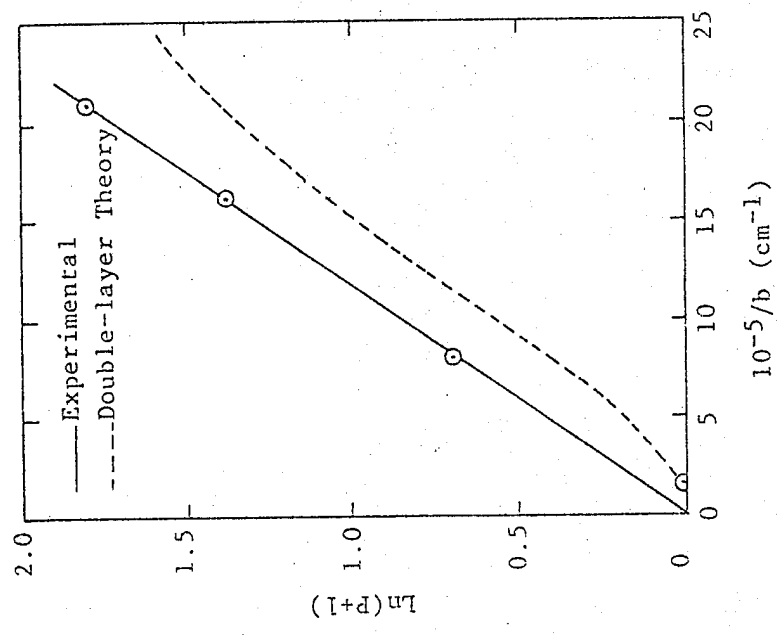

Clay Spur montmorillonite

Figure 18. Comparison of Experimental and Predicted Swelling Pressures (Low and Margheim, 1979).

- The loss of elongation of the polymeric membranes as a function of time when in contact with the waste or its leachate.
- The use of a bag test for measuring the compatibility of the liners and the waste and the permeability of the liner to the constituents of the waste.

V. CONCLUSIONS

The available information on hazardous wastes compatibility with the various liner materials is presented in Table XI. Where no information was available on a specific component of the waste, it was not included in the table. As can be observed from the table, the ability of a liner material to contain a waste is a function of the basic polymeric liner material. It is also very dependent on the additives, e.g. plasticizers, carbon, etc., used in the formulation of the liner material.

Several conclusions can be drawn from this review of the available information on compatibility testing of barrier/liner materials:

- 1) only a limited number of long-term studies have been performed on liner material compatibility with various hazardous wastes
- 2) short-term tests to predict long-term liner/waste compatibilities are only now being developed
- 3) the state-of-the-art in predicting liner material/waste compatibility is still in its infancy
- 4) prediction of waste compatibility with bentonite is possible by extending models developed in the study of soil science
- 5) no models are available to predict long-term membrane liner compatibility with hazardous wastes
- 6) the only methods available to determine compatibility of membrane liners with hazardous wastes are long-term and temperature accelerated short-term tests. The accelerated short-term test may or may not be an accurate predictor of long-term membrane liner waste compatibility. In addition, each hazardous waste membrane combination must be individually tested.
- 7) no information was found on liner compatibility with the specific hazardous materials of interest to the Army.
- 8) In addition to waste/liner materials compatibility, the selection of a liner material for a specific job must also take into account the terrain, geohydrological and weather conditions encountered at the site.

Table XI. Summary of Resistances of Liner Materials to Lagoon and Landfill Conditions

Harmful Conditions	Bentonite		Butyl Rubber		Ethylene Propylene Rubber		Polyethylene		Chlorinated Polyethylene		Chloro-sulfonated Polyethylene (Hypalon)		Polypropylene		Polyvinyl Chloride		Poly-chloroprene (Neoprene)		Elasticated Polyolefins		
	self-healing	healing	good	excellent	good	good	poor	poor	poor	excellent	poor	excellent	poor	good	poor	good	good	good	good	excellent	
UV radiation	-	-	good	excellent	good	good	poor	poor	-	-	excellent	excellent	poor	poor	poor	good	good	good	good	excellent	
temperature extremes	-	-	good	excellent	good	good	poor	poor	-	-	poor	-	good	good	-	good	good	good	good	good	
abrasion and punctures	self-healing	healing	good	excellent	good	good	poor	poor	-	-	poor	poor	good	good	good	good	good	good	good	good	
biological growth	-	-	-	excellent	-	-	excellent	good	good	good	moderate	moderate	-	-	-	plasticizers biodegradable	good	good	good	good	
Harmful Chemicals and Materials																					
heavy metals	good	-	-	-	-	-	-	-	-	-	-	-	-	-	-	-	-	-	-	-	
inorganic salts	poor	-	excellent	-	-	-	-	-	-	-	very good	-	-	-	-	good	-	-	-	-	
silicates	-	-	-	-	good	good	-	-	-	-	-	-	-	-	-	-	-	-	-	-	
phosphates	-	-	-	-	good	good	-	-	-	-	-	-	-	-	-	-	-	-	-	-	
brine	-	-	-	-	good	good	-	-	-	-	-	-	-	-	-	-	-	-	-	-	
acids	poor	-	-	-	good	good	-	poor	poor	-	-	-	-	-	-	-	good	good	good	good	
dilute acids	-	-	-	-	good	good	-	-	-	-	-	-	-	-	-	-	good	good	good	good	
bases	-	-	-	-	good	good	-	-	-	-	-	-	-	-	-	-	good	good	good	good	
oxidizing chemicals	-	-	excellent	-	-	-	-	-	good	good	very good	poor	poor	poor	poor	poor	poor	poor	poor	poor	
ozone	-	-	good	good	good	good	-	-	-	-	excellent	excellent	-	-	-	-	-	-	-	-	
hypochlorites	-	-	-	-	-	-	-	-	-	-	-	-	-	-	-	-	-	-	-	-	
sulfides	-	-	-	-	-	-	-	-	-	-	-	-	-	-	-	-	-	-	-	-	
solvents	-	-	-	-	-	-	-	-	-	-	moderate	-	-	-	-	-	-	-	-	-	
organics	-	-	-	-	-	-	-	-	-	-	-	-	-	-	-	-	-	-	-	-	
hydrocarbons	-	-	poor	-	poor	poor	-	-	-	-	-	-	-	-	-	-	-	-	-	fair	
chlorinated hydrocarbons	-	-	-	-	-	-	-	-	-	-	-	-	-	-	-	-	-	-	-	fair	
aromatics	-	-	-	-	poor	poor	-	poor	poor	poor	poor	poor	poor	poor	poor	poor	poor	poor	poor	poor	
phenols	good	-	-	-	-	-	-	-	-	-	-	-	-	-	-	-	-	-	-	-	
alcohols	-	-	-	-	-	-	-	-	-	-	-	-	-	-	-	-	-	-	-	-	
ketones	-	-	-	-	-	-	-	-	-	-	-	-	-	-	-	-	-	-	-	-	
glycols	-	-	-	-	-	-	-	-	-	-	-	-	-	-	-	-	-	-	-	-	
waxes	-	-	-	-	-	-	-	-	-	-	-	-	-	-	-	-	-	-	-	-	
oils	good	-	excellent	-	-	-	good	good	poor	poor	moderate	moderate	good	good	good	good	good	good	good	good	
fats	-	-	excellent	-	-	-	-	-	-	-	-	-	-	-	-	-	-	-	-	-	
sewage	-	-	excellent	-	-	-	good	good	-	-	-	-	-	-	-	-	-	-	-	-	

VI. RECOMMENDATIONS

Before the Army considers lining lagoons or landfills containing military unique hazardous wastes, e.g. diisopropylmethylphosphonate, dimethylmethylphosphonate, explosives, etc., it is recommended that long-term compatibility be run with the wastes and various liner materials under consideration. These tests should run at least 2 years. If time is not available to perform long-term tests, accelerated short-term tests can be used. However, the results of these tests must be interpreted with caution.

In the field of predicting liner/waste compatibility, it is recommended that the long-term compatibility studies being conducted by Haxo at Matrecon, Inc. for EPA receive continued attention. The forthcoming publication of the National Sanitation Foundation covering liner technology and a standardized method for accelerated liner compatibility testing should also be carefully reviewed. It is also recommended that the preliminary model of bentonite waste compatibility be extended to include effects of other cations, anions and organics on the bentonite.

VII. REFERENCES

- American City and County (1977), "What's new in landfill liners," 92(2), 54-56.
- American Colloid Company (1971), "Volclay. Its use in slurry trenching and diaphragm wall construction projects," product brochure, no. 260.
- American Colloid Company (1975), "The Volclay® natural barrier phenomenon for seepage control and water impedance," product brochure, no. 229-D.
- American Colloid Company (1978), "Volclay seepage control systems," product brochure.
- Baker, J.W. (1970), "Propylene fiber mat and asphalt used for oxidation pond liner," Water Wastes Eng., 7(11), F-17, F-20-21.
- Borchardt, G.A. (1977), "Montmorillonite and other smectite minerals," Minerals in Soil Environments, J.B. Dixon and S.P. Weed, editors, Soil Science Society of America, Madison, WI, Chapter 9, 293-330.
- Brown Company (1980), Personal communication, Berlin, NH.
- Brown, K. (1980), Personal communication, Texas A & M University, College Station, TX.
- Brown, K.W. and D. Anderson (1980), "Effect of organic chemicals on clay liner permeability," Disposal of Hazardous Waste, Proceed. 6th Ann. Res. Symp., D. Shultz, editor, EPA-600/9-80-010, 123-134.
- Bucciarelli, W.C. (1976), "Pennsylvania uses liners to control groundwater contamination from landfill operations," J. Environ. Health, 39(3), 184-185.
- Buntrock, C. (1980), Personal communication, Wheeling Disposal Service, Co., Inc., St. Josephs, MO.
- Burke Rubber Company (undated), "Hypalon® FROM Burke. For jobs no other pond liner or cover can handle," product brochure.
- Chemical Processing (1979), "Specially processed bentonite seals pond against seepage," reprint.
- Clark, D.A. and J.E. Moyer (1974), "An evaluation of tailings ponds sealants," Environmental Protection Agency, report EPA-660/2-74-065.
- Contractors & Engineers Magazine (1971), "Plastic liners lick porous pumice problem. Cells dug in sandy pumice for water-supply/sewage treatment system," reprint.
- Dallaire, G. (1975), "Tougher pollution laws spur use of impermeable liners," Civil Engineering-ASCE, 45(5), 63-67.

- Du Pont (undated), "Flexible membranes for pond and reservoir liners and covers. Hypalon®, synthetic rubber, Neoprene, synthetic rubber, Nordel® hydrocarbon rubber, 3111™ elasticized polyolefin," product brochure.
- Fisher, G. (1980), Personal communication, Du Pont, Louisville, KY.
- Fung, R. (1980), Protective Barriers for Containment of Toxic Materials, Noyes Data Corp., NJ. Pollution Technology Review, No. 66.
- Gast, R.G. (1977), "Surface and colloid chemistry," Minerals in Soil Environments, J.B. Dixon and S.P. Weed, editors, Soil Science Society of America, Madison, WI, Chapter 2, 27-73.
- Geswein, A.J. (1975), "Liners for land disposal sites. An assessment," Environmental Protection Agency, report EPA/530/SW-137. NTIS, PB 261 046.
- Goodrich, BF (1978), "Service condition suggestions for Flexseal™ linings," product brochure.
- Griffin, R.A. and N.F. Shimp (1975), "Interaction of clay minerals and pollutants in municipal leachate," Proceed. 2nd Nat'l Conf. Comp. Water Reuse, Water's Interf. Energy, Air Solids, 801-811.
- Grim, R.E. (1979), "Clays," Kirk-Othmer Encyclopedia of Chemical Technology, 3rd edition, R.E. Kirk, D.F. Othmer, M. Grayson and D. Eckroth, editors, John Wiley & Sons, NY, 6, 190-223.
- Gupta, V.L. and M.J. Miles (1979), "Containment pond technology. State-of-the-art," Water Resources Center, report on contract S0271043(4).
- Haxo, H.E. Jr. and R.M. White (1976), "Evaluation of liner materials exposed to leachate, second interim report," Matrecon, Inc., report EPA-600/2-76-255.
- Haxo, H.E. Jr.; R.S. Haxo and R.M. White (1977), "Liner materials exposed to hazardous and toxic sludges. First interim report," Matrecon, Inc., report EPA-600/2-77-081.
- Haxo, H.E. Jr. (1977), "Compatibility of liners with leachate," Management of Gas and Leachate in Landfills, Proceed. 3rd Ann. Municipal Solid Waste Res. Symp. report EPA-600/9-77-026, 149-158.
- Haxo, H.E. Jr. (1979) "Liner materials exposed to MSW landfill leachate," Municipal Solid Waste: Land Disposal, Proceed. 5th Ann. Res. Symp., M.P. Wanielista and J.S. Taylor, editors, report EPA-600/9-79-023a, 241-267. NTIS, PB80-114 291.
- Haxo, H.E. Jr.; R.S. Haxo and T.F. Kellogg (1979), "Liner materials exposed to municipal solid waste leachate. Third interim report," Matrecon, Inc., report EPA-600/2-79-038. NTIS, PB 299 336.

- Haxo, H.E. Jr. (1980), "Interaction of selected lining materials with various hazardous wastes-II," Disposal of Hazardous Waste, Proceed. 6th Ann. Res. Symp., D. Shultz, editor, report EPA-600/9-80-010, 160-180. NTIS, PB80-175 086.
- Johnson, P.E. and S.W. Cole (1976), "Bentonite-glacial till the right mixture for lining Brown Co. Cascade Mill lagoons," Paper Trade J., 160(16), 36-37, +.
- Karnes, Wm. (1980), Personal communication, Buckeye Cellulose, Perry, FL.
- Kemper, W.D. and J.P. Quirk (1970), "Graphic presentation of a mathematical solution for interacting diffuse layers," Soil Sci. Soc. Am. Proceed., 34(2), 347-350.
- Kersten, J. (1980), Personal communication, Palco Linings, Stanton, CA.
- Kinard, A.J. and F.P. Tuenge (1979), "Landfill cell designed for hazardous waste disposal," Public Works Magazine, reprint.
- Langmuir, I. (1938), "The role of attractive and repulsive forces in the formation of tactoids, thixotropic gels, protein crystals and coacervates," J. Chem. Phys., 6, 873-900. In: "The swelling of clay: I. basic concepts and empirical equations," P.F. Low and J.F. Marghein, Soil Sci. Soc. Am. J., 43(3), 473-481.
- Lee, J. (1974), "Selecting membrane pond liners," Pollution Engineering, 6(1), 33-40.
- Low, P.F. and J.F. Marghein (1979), "The swelling of clay: I. basic concepts and empirical equations," Soil Sci. Soc. Am. J., 43(3), 473-481.
- Lurcott, J. (1980), Personal communication, Rollins Environmental Services, Wilmington, DE.
- McNeal, B.L. (1970), "Prediction of interlayer swelling of clays in mixed-salt solutions," Soil Sci. Soc. Am. Proceed., 34(2), 201-206.
- Middlebrooks, E.J.; C.D. Perman and I.S. Dunn (1978), "Wastewater stabilization pond linings," Middlebrooks and Associates, report Special Report 78-28. NTIS, AD A062 903.
- Motley, L.N. and R.F. McKendrick (1979), "Groundwater protection governs treatment-pond design," Power, 123(12), 41-42.
- Pelloquin, L. (1972), "Pond liner serves dual role," Water Wastes Eng., 9(3), B-15.
- Rodgers, E. (1980), Personal communication, Kerr McGee, Henderson, NV.
- Rook, H.E. (1975), "Rubber lining helps leaking reservoir 'bounce' back," The American City, June, 94-96.

Schlegel® (1977), "Area sealing systems," product brochure.

Slifer, W. (1976), "Flexible liners in landfills," Land Application of Residual Materials, Eng. Found. Conf., ASCE, 169-177.

Smith, R.H. (1976), "Assessing clay as a landfill liner material," Waste Age, 7(9), 59-60, 62.

Staff Industries (1980), "Thank you for your inquiry...", product brochure.

Staub, W.P. and E.K. Triegel (1978), "Analysis of disposal of uranium mill tailings in a mined out open pit," OECD Stabilization & Environmental Impact of Uranium Mill Tailings Conf., 18, 353-371.

Stewart, W.S. (1978), "State-of-the-art study of land impoundment techniques," Exxon Research & Engineering Company, report EPA-600/2-78-196.

Styron, C.R. III and Z.B. Fry, Jr. (1979), "Flue gas cleaning sludge leach-
age/liner compatibility investigation: interim report," U.S. Army Engi-
neer Waterways Experiment Station, report EPA-600/2-79-136.

Surtees, L. (1980), Personal communication, Kerr-McGee, Oklahoma City, OK.

Vandervort, J. (1980), Personal communication, Schlager, Houston, TX.

Water & Wastes Engineering (1977), "Ponds 'down under' are lined with polyolefin sheet," 50.

Williams, R.E. (1978), "Control and Prevention of seepage from uranium mill waste disposal facilities," OECD Stabilization & Environmental Impact of Uranium Mill Tailing Conf., 12, 287-297.