

**U.S. ARMY
MATERIEL DEVELOPMENT
AND READINESS COMMAND**

DTIC
SELECTE
DEC 24 8 1995
S **D**
B

MANUFACTURING
METHODS &
TECHNOLOGY
**PROJECT SUMMARY
REPORTS**

19951220 041

(RCS DRCMT-302)

PREPARED BY

**USA INDUSTRIAL BASE ENGINEERING
ACTIVITY**

MANUFACTURING TECHNOLOGY DIVISION

ROCK ISLAND, ILLINOIS 61299

DEPARTMENT OF DEFENSE
PLASTICS TECHNICAL EVALUATION CENTER
ARRADCOH, DOVER, N. J. 07801

DEC 81

DTIC QUALITY INSPECTED 3

DISTRIBUTION STATEMENT A
Approved for public release
Distribution Unlimited

PLASTIC
2/19/97

DISCLAIMER NOTICE

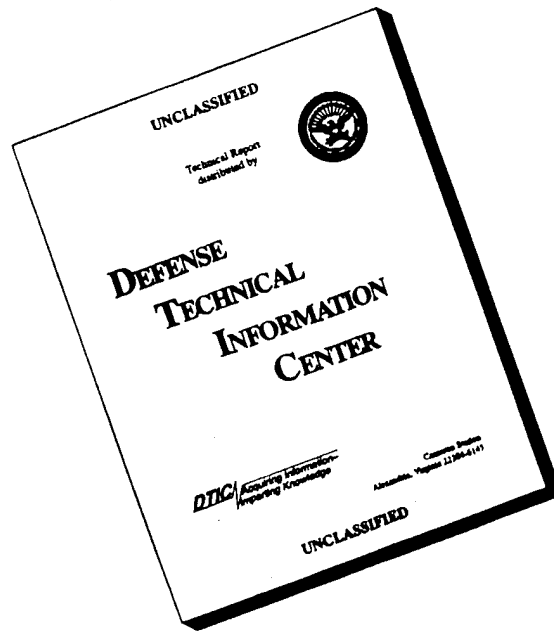

THIS DOCUMENT IS BEST QUALITY AVAILABLE. THE COPY FURNISHED TO DTIC CONTAINED A SIGNIFICANT NUMBER OF PAGES WHICH DO NOT REPRODUCE LEGIBLY.

- END Y FOR NEXT ACCESSION END

1 OF 1

DTIC DOES NOT HAVE THIS ITEM

- 1 AD NUMBER: D434767
- 3 CORPORATE AUTHOR: ARMY INDUSTRIAL BASE ENGINEERING ACTIVITY ROCK ISLAND IL
- 6 UNCLASSIFIED TITLE: MANUFACTURING METHODS AND TECHNOLOGY PROJECT SUMMARY REPORTS.
- 11 REPORT DATE: DEC , 1981
- 12 PAGINATION: 186P
- 20 REPORT CLASSIFICATION: UNCLASSIFIED
- 22 LIMITATIONS (ALPHA): APPROVED FOR PUBLIC RELEASE; DISTRIBUTION UNLIMITED. ~~AVAILABILITY STATEMENT: UNCLASSIFIED, U. S. ARMY MATERIEL DEVELOPMENT AND READINESS COMMAND, ATTN: BRCH, 5051 EISENHOWER AVE, ALEXANDRIA, VA. 22304.~~
- 33 LIMITATION CODES: 1

- END Y FOR NEXT ACCESSION END



DEPARTMENT OF THE ARMY
US ARMY INDUSTRIAL BASE ENGINEERING ACTIVITY
ROCK ISLAND, ILLINOIS 61299

REPLY TO
ATTENTION OF:

89 JAN 1982

DRXIB

SUBJECT: Manufacturing Methods and Technology Program Project Summary
Report (RCS DRCMT-302)

SEE DISTRIBUTION (Appendix II to Inclosure 1)

1. In compliance with AR 700-90, C1, dated 10 March 1977, the Industrial Base Engineering Activity (IBEA) has prepared the inclosed Project Summary Report.
2. This Project Summary Report is a compilation of MMT Summary Reports prepared by IBEA based on information submitted by DARCOM major subordinate commands and project managers. These projects represent a cross section of the type of efforts that are being conducted under the Army's Manufacturing Methods and Technology Program. Persons who are interested in the details of a project should contact the project officer indicated at the conclusion of each individual report.
3. Additional copies of this report may be obtained by written request to the Defense Technical Information Center, ATTN: TSR-1, Cameron Station, Alexandria, VA 22314.

1 Incl
as

J. R. GALLAUGHER
Director
Industrial Base Engineering Activity

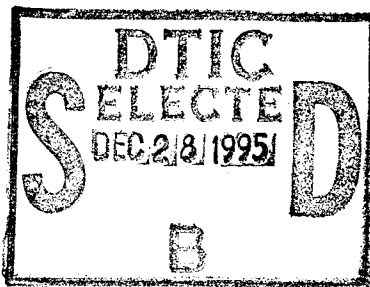
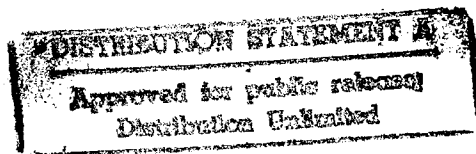

REPORT DOCUMENTATION PAGE		READ INSTRUCTIONS BEFORE COMPLETING FORM
1. REPORT NUMBER	2. GOVT ACCESSION NO.	3. RECIPIENT'S CATALOG NUMBER
4. TITLE (and Subtitle) MANUFACTURING METHODS AND TECHNOLOGY PROJECT SUMMARY REPORTS		5. TYPE OF REPORT & PERIOD COVERED Semi-Annual July - December 1981
		6. PERFORMING ORG. REPORT NUMBER
7. AUTHOR(s) Manufacturing Technology Division US Army Industrial Base Engineering Activity		8. CONTRACT OR GRANT NUMBER(s)
9. PERFORMING ORGANIZATION NAME AND ADDRESS US Army Industrial Base Engineering Activity ATTN: DRXIB-MT Rock Island, IL 61299		10. PROGRAM ELEMENT, PROJECT, TASK AREA & WORK UNIT NUMBERS
11. CONTROLLING OFFICE NAME AND ADDRESS HQ, DARCOM, US Army Materiel Development and Readiness Command, ATTN: DRCMT, 5001 Eisenhower Avenue, Alexandria, VA 22333		12. REPORT DATE December 1981
		13. NUMBER OF PAGES 186
14. MONITORING AGENCY NAME & ADDRESS (if different from Controlling Office)		15. SECURITY CLASS. (of this report)
		15a. DECLASSIFICATION/DOWNGRADING SCHEDULE
16. DISTRIBUTION STATEMENT (of this Report) Distribution unlimited. Document for public release.		
17. DISTRIBUTION STATEMENT (of the abstract entered in Block 20, if different from Report) Distribution unlimited. Document for public release.		
18. SUPPLEMENTARY NOTES		
19. KEY WORDS (Continue on reverse side if necessary and identify by block number) Manufacturing methods Manufacturing technology Technology transfer MMT Program		
20. ABSTRACT (Continue on reverse side if necessary and identify by block number) This report contains summaries of 79 projects that were completed under the Army's Manufacturing Methods and Technology (MMT) Program. The MMT program was established to upgrade manufacturing facilities used for the production of Army Materiel. The summaries highlight the accomplishments and benefits of the projects and the implementation actions underway or planned. Points of contact are also provided for those who are interested in obtaining additional information.		

TABLE OF CONTENTS

PAGE

Disclaimer	Inside Front Cover
Introduction	1
Achievements	3
Technological Advancements	4
Cost Reductions	6
Safety	9

CAD/CAM

<u>Project 278 9773</u> - MM&T Computer Program Aid for Preparation of Automatic Analog Circuit Production Test Programs	11
<u>Project 574 4500</u> - Modernized Testing Technology Providing for Immediate Data Acquisition, Reduction and Dissemination, CAM Related	14
<u>Project 575 4500</u> - Modernized Testing Technology Providing for Immediate Data Acquisition, Reduction and Dissemination, CAM Related	17
<u>Project 576 4500</u> - Modernized Testing Technology Providing for Immediate Data Acquisition, Reduction and Dissemination, CAM Related	19
<u>Project 679 8104</u> - Improved Breech Mechanism Manufacturing	21

ELECTRONICS

<u>Project 272 9359</u> - MM&T- Integrated Circuit Power Amplifier for Tactical Radio Equipment	24
<u>Project 272 9379</u> - Low Noise Solid State Local Oscillator	27
<u>Project 275 9441</u> - Arc Plasma Sprayed Phase Shift Elements	30
<u>Project 275 9836</u> - Establishment of Quality Control Techniques for Fabrication of 18mm and 25mm Etched Core Microchannel Plates	33
<u>Project 276 9754</u> - MM&T Continuous Cycle Processing of Shock Resistant Quartz Crystal Units	35

print included
DTIC memo
10/27/95

Availability Codes	
Dist	Avail and/or Special
A-1	

Tables of Contents (Continued)

	<u>PAGE</u>
<u>Project 277 9831</u> - Pilot Manufacture of Rugged L-Band Crystal Controlled Telemetry Transmitter	38
<u>Project 374 3096</u> - Manufacturing Processes for Laser Terminal Homing Seekers	41
<u>Project 375 3073 and 376 3073</u> - Manufacturing Techniques for Static Switches	44
<u>Project 377 3217</u> - Manufacturing Methods for Traveling Wave Tubes	47
<u>Project 378 3140</u> - Improved Manufacturing Processes for Silicon Vidicons	50
<u>Project 577 3905</u> - PS127 Reserve Power Supply Manufacturing for the M587/724 Fuze	53
<u>Project 672 7191</u> - Long Wavelength Optical Fabrication Techniques for Far Infrared	56
<u>Project E78 3532</u> - Molten Salt Lithium/Chlorine Battery	58
<u>Project H73 9605</u> - Thin Film Ratiometer	60
<u>Project R77 3112</u> - MM&T- Manufacturing Multilayer Rigid-Flex Harness	63
<u>Project R77 3133</u> - Production of Lithium Ferrite Phase Shifters for Phased Array Radars	66
<u>Projects R77 3452 and R78 3452</u> - Low Cost Quantity Production Techniques for Laser Seekers	69
<u>Project R78 3253</u> - Manufacturing Methods for Thin-Film Field Emission Cathodes	72
<u>Project R78 3436</u> - Development of Ceramic Circuit Boards and Large Area Hybrids	75

INSPECTION AND TEST

<u>Projects 177 7144 and 178 7144</u> - T700 Engine Nozzle In-Process Inspection	78
<u>Project 380 3169</u> - Automatic Optical Inspection of Printed Circuit Boards and Components (CAM)	81

Tables of Contents (Continued)

	<u>PAGE</u>
<u>Project 575 3077</u> - Production Methodology for the Validation of Electronic Fuzes	84
<u>Project R78 3075</u> - Infrared Testing of Printed Circuit Boards and Microcircuits	86
<u>METALS</u>	
<u>Projects 174 8148, 175 8148, and 176 8148</u> - Processing of Advanced Gear Materials	89
<u>Projects 475 4557 and 477 4557</u> - Production Method for High Efficiency Joining of ESR Armor	91
<u>Projects 574 6576 and 575 6576</u> - Application of High Speed Boring for Large Caliber Shell Used With Production Equipment on Improved Conventional Munitions	93
<u>Project 577 4410</u> - Manufacturing Tungsten Penetrators by Taper Swaging	95
<u>Project 577 6678</u> - Evaluation of Aqua-Quench Under Production Conditions	96
<u>Project 577 6777</u> - Development of a Production Process for 105mm XM710E1 Artillery Projectile Metal Parts	99
<u>Project 578 6681</u> - Process Parameters for Production Forming of Projectiles	100
<u>Project 677 7711</u> - Establish Improved Electropolishing Process for Armament Components	103
<u>Projects 677 7716 and 678 7716</u> - Prototype Production Line for Pressure Phosphate Coating	106
<u>Project 677 7722</u> - Rotary Forging of 8" M201	109
<u>Projects E77 3588 and E78 3588</u> - SLUFAE Mine Neutralizer Launcher	111
<u>Project R78 3121</u> - Application and NDT of Line Pipe for Motor Components	113

MUNITIONS

<u>Projects 571 6494, 573 6494, and 574 6494</u> - New Concepts for Manufacture and Inspection of Cal .50, 20mm and 30mm Ammunition	117
---	-----

Tables of Contents (Continued)

	<u>PAGE</u>
<u>Projects 574 4099 and 575 4099 - Hazard Analysis and Classification of Pyrotechnic Compositions and Operations</u>	120
<u>Projects 577 1320 and 578 1320 - Pilot Stations for Filling and Closing Improved WP Munitions</u>	123
<u>Project 578 4252 - Improve Present Processes for the Manufacture of RDX and HMX</u>	126
<u>Project 578 4285 - TNT Equivalency Testing in Support of Safety Engineering for Ammunition Plants</u>	129
<u>Project 578 4508 - Process Improvement of Pressable RDX Compositions</u>	132
<u>Project 579 4291 - Blast Effects in the Munition Plant Environment</u>	135
<u>NON-METALS</u>	
<u>Projects 376 3229, 37T 3229 and R78 3229 - Methodology for Producing Low Cost/Disposable Mandrels</u>	139
<u>Project 576 1311 - MMT for the M229 Refill Kit Component of the Chemical Agent Alarm</u>	141
<u>Project 577 1312 - Manufacturing Methods and Technology for Paper, Chemical Agent, Detector, M8</u>	144
<u>Project 577 4481 - Pyrolysis of Army Ammunition Plant Solid Waste</u>	147
<u>Projects 579 4084 and 580 4084 - Opacity/Mass Emission Correlation Study</u>	150
<u>Projects 672 7062 and 673 7062 - Optical Polishing Technology</u>	153
<u>Project 674 7271 - Glass Coated Plastic Optics</u>	156
<u>Project 675 7497 - Extended Use Optical Tooling</u>	158
<u>Project 678 7933 - MM&T: Central Coolant Systems</u>	160
<u>Project 773 8025 - Manufacturing Techniques of 3D Fabrics</u>	163
<u>Projects 774 3508 and 775 3508 - Production of Dry Composite Membranes for Reverse Osmosis</u>	166

Tables of Contents (Continued)

	<u>PAGE</u>
<u>Project 776 5504</u> - Production of Phosphazene Elastomers	168
<u>Project H78 9841</u> - Zinc Selenide Windows and Optical Elements	171
<u>Project R78 3150</u> - Develop Methodology for Utilizing Ultraviolet Cured Conformal Coatings	174

APPENDIX I

Army MMT Program Offices	178
--------------------------	-----

APPENDIX II

Distribution	181
--------------	-----

INTRODUCTION

Background

The Manufacturing Methods and Technology (MMT) Program was established to upgrade manufacturing facilities used for the production of Army materiel, and as such, provides direct support to the Industrial Preparedness Program. The Manufacturing Methods and Technology Program consists of projects which provide engineering effort for the establishment of manufacturing processes, techniques, and equipment by the Government or private industry to provide for timely, reliable, economical, and high-quality quantity production means. The projects are intended to bridge the gap between demonstrated feasibility and full-scale production. The projects are normally broad based in application, are production oriented, and are expected to result in a practical process for production. The projects do not normally include the application of existing processes, techniques, or equipment to the manufacture of specific systems, components, or end items, nor do they apply to a specific weapon system development or a product improvement program.

MMT Program Participation

MMT Programs are prepared annually by DARCOM major subordinate commands. These programs strive for the timely establishment or improvement of the manufacturing processes, techniques, or equipment required to support current and projected programs.

Project proposals (Exhibits P-16) are submitted to the appropriate MMT Program Office. A list of offices is provided in Appendix I. Additional information concerning participation in the MMT Program can be obtained by contacting an office listed or by contacting Mr. James Carstens, AUTOVON 793-5113, or Commercial (309) 794-5113, Industrial Base Engineering Activity, Rock Island, IL 61299.

In anticipation of the lengthy DOD funding cycles, projects must be submitted in sufficient time for their review and appraisal prior to the release of funds at the beginning of each fiscal year. Participants in the program must describe manufacturing problems and proposed solutions in Exhibit P-16 formats (see AR 700-90, 4 August 1975, for instructions). Project manager offices should submit their proposals to the command that will have mission responsibility for the end item that is being developed.

Contents

This report contains summaries of 79 completed projects that were funded by the MMT Program. The summaries are prepared from Project Status Reports (RCS DRCMT-301) and Final Technical Reports submitted by organizations executing the MMT projects. The summaries highlight the accomplishments and benefits of the projects and the implementation actions under way or planned. Points of contact are also provided for those interested in obtaining additional information.

The MMT Program addresses the entire breadth of the Army production base and, therefore, involves many technical areas. For ease of referral, the project summaries are grouped into six technical areas. The technical areas are: CAD/CAM, Electronics, Inspection and Test, Metals, Munitions, and Non-Metals.

The Summary Reports are prepared and published for the Office for Manufacturing Technology, DARCOM, by the Manufacturing Technology Division of the US Army Industrial Base Engineering Activity (IBEA) in compliance with AR 700-90, C1. The report was compiled and edited by Mr. Andrew Kource, Jr. and ably assisted by Mrs. Eileen Griffing and Mrs. Debra O'Connor with the typing and graphics arrangements.

ACHIEVEMENTS

This section contains abstracts of the key project achievements in this report. Attention is being focused on these projects because of significant benefits which are manifested through either technological advancements, cost reductions, or safety. This listing is not inclusive of all beneficial projects. Whether a project is beneficial or not depends upon one's needs. Therefore, even though the abstract of a project does not appear in this section, the reader should examine the body of this report for results that may suit his particular requirements.

TECHNOLOGICAL ADVANCEMENTS

<u>Project Number</u>	<u>Project Title</u>	<u>Page</u>
679 8104	Improved Breech Mechanism Manufacturing	21

The concept of flexible manufacturing systems (FMS) offers the economics of mass production to mid-volume manufacturing. Through the integration of work stations, material handling equipment, and computer control, a family of similar parts can be manufactured with minimum direct labor. An industry analysis was performed and then a scope of work was prepared with performance specifications to support the purchase of an FMS for Watervliet Arsenal.

577 3905	PS127 Reserve Power Supply Manufacturing for the M587/724 Fuze	53
----------	--	----

The objective of this project was to develop and demonstrate processes and pilot facilities to aid producibility of the PS127 power supply at minimum costs. This project advanced the state of the art for fabricating and coating electrodes in a mechanized manner. The technology that was developed can be applicable to reserve batteries for other fuzes.

578 1320	Pilot Stations for Filling and Closing Improved WP Munitions	123
----------	--	-----

This project proved out with production-type equipment, the filling and closing techniques for a new white phosphorus filled smoke rocket. The equipment was then used to establish an initial production capability for the munition. In addition, a low-rate loading, assembling, and packing capability was established for the complete rocket.

R78 3229	Methodology for Producing Low Cost/ Disposable Mandrels	139
----------	---	-----

This project established the manufacturing methodology for producing low cost/disposable mandrels for solid propellant rocket motors. Extensive evaluations of candidate mandrel plastic materials as to cost, fabrication techniques, structural characteristics, compatibility with propellant, and dimensional control were conducted.

580 4084

Opacity/Mass Emission Correlation Study

150

The objective of this project was to determine if an empirical relationship between opacity and particulate mass concentration could be established. This relationship would be used to estimate particulate mass emissions from opacity data recorded at other similar plant forging operations. A correlation was established between particle concentration and opacity. This allowed the use of opacity measurements as an alternative to the more expensive traditional mass emission measurement techniques.

COST REDUCTIONS

<u>Project Number</u>	<u>Project Title</u>	<u>Page</u>
278 9773	MMT Computer Program Aid for Preparation of Automatic Analog Circuit Production Test Programs	11

The objective of this project was to reduce the direct labor costs for the preparation of Automatic Test Equipment (ATE) programs for testing linear analog circuits. The five basic analog units under test considered were analog amplifiers, oscillators, power supplies, mixers, and filters. The approach used was to extend the capability of the previously developed ATLAS Test Program Generator I (AGEN I) system. It is estimated that the time required to develop a test program for one of the five circuits can be reduced by 70% using AGEN II; however, the user of the system will not be required to write network equations or possess any knowledge of computer programming to operate the system.

576 4500	Modernized Testing Technology Providing for Immediate Data Acquisition, Reduction and Dissemination, CAM Related	19
----------	--	----

This effort reduced the costs and delays associated with the reduction and analysis of ballistic firing test data. The approach was to design and develop digital computer systems with data acquisition and data reduction capabilities. The systems rapid analysis of an item's flight characteristics allowed the early detection of a defective sample from a production lot. Also, difficulties encountered in the flight of each item fired could be determined. Testing cost reduction is anticipated through consolidated and reduced instrumentation, manpower, and number of units tested.

272 9379	Low Noise Solid State Local Oscillator	27
----------	--	----

Local oscillators used in portable radars and microwave communications equipment generate both AM and FM noise which limits system range and performance. It was determined that Ku and X-band devices could be improved by optimizing and controlling the bulk semi-conductor material, the internal structure of the oscillator, and the operating cavity. Manufacturing methods were developed which reduced the cost of oscillators by approximately 40 per cent.

275 9836 Establishment of Quality Control
Techniques for Fabrication of
18mm and 25mm Etched Core Micro-
channel Plates

33

A quality control system was developed and documented for all phases of microchannel plate (MCP) production which would meet the criteria set forth in MIL-Q-9858A. The quality of the processing stations was verified by obtaining data on units built on a pilot line. MCP device quality and yields were significantly improved. A cost reduction of \$100 per MCP is anticipated.

378 3140 Improved Manufacturing Processes
for Silicon Vidicons

50

The objective of this project was to develop a production plan for rugged, high-quality silicon vidicons, with emphasis on the critically precise silicon disk. A goal of this project was to reduce the silicon vidicon's susceptibility to "blooming" which is a temporary loss of visual information caused by excessive incoming light. This was successfully met by the "landing pad" design which also enhanced image resolution and reduced the level of current leakage. The contractor estimated that the price could be reduced from \$5000 to \$625 when produced in quantities of 2,500 units.

R77 3112 Manufacturing Multilayer Rigid-Flex
Harness

63

A cannon-launched artillery shell with terminal infrared guidance failed when it was test fired during the development phase. Failure analysis on defective systems indicated that breakdown was caused by tears and breaks in the "motherboard" of the guidance electronic assembly. This project was undertaken to improve motherboard reliability by selecting optimum materials and improving manufacturing procedures. As a result of this project, a material savings of \$43 per board and a 25 per cent yield improvement was attained.

380 3169 Automatic Optical Inspection of
Printed Circuit Boards and Components
(CAM)

81

The objective of this project was to develop an automated inspection system with operating procedures which could detect the majority of problems encountered in printed circuit

board (PCB) manufacturing. The prototype system developed consisted of a very low power helium neon laser, an X-Y moving galvanometer scanner, and several folding mirrors. Based on the production prototype demonstration, the laser system increased productivity and decreased labor costs three ways.

H78 9841

Zinc Selenide Windows and Optical
Elements

171

Production costs of zinc selenide windows were to be reduced by the automation of existing methods. A full automated process for the production of these items was developed by a contractor.

SAFETY

<u>Project Number</u>	<u>Project Title</u>	<u>Page</u>
575 4099	Hazards Analysis and Classification of Pyrotechnic Compositions and Operations	120

The objective of this project was to develop sensitivity tests, classification procedures, criteria, and hazards analysis applicable to all pyrotechnic materials and operations. The benefits of this project are new and improved test methods for determining the hazard classification of loose and packaged pyrotechnic compositions. A better knowledge was gained as to their accidental initiation or discharge during manufacturing, handling, storage, and transportation.

578 4285	TNT Equivalency Testing in Support of Safety Engineering for Ammunition Plants	129
----------	--	-----

The US Army has been involved in a continuing program to upgrade the safety standards of new and existing ammunition plants. The purpose of this project was to generate peak pressure and positive impulse data from blast measurements of a variety of high energy materials, explosives and propellants. Considerable cost savings can be realized by using the data developed.

579 4291	Blast Effects in the Munition Plant Environment	135
----------	---	-----

This project developed data and criteria not presently available for the response characteristics in a blast environment of cold-formed steel panels used in buildings. This information was used to expand the scope of the safety manual TM5-1300.

COMPUTER AIDED DESIGN/ COMPUTER AIDED MANUFACTURING (CAD/CAM)

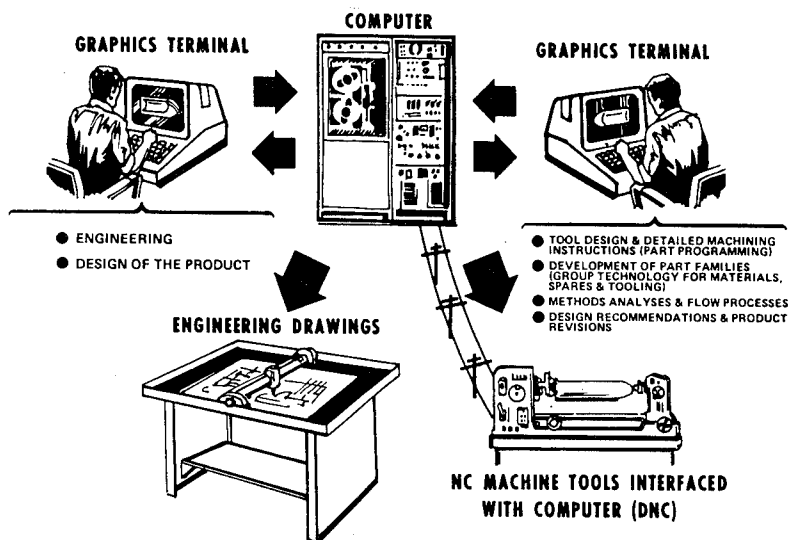

INFORMATIONAL FLOW IN A COMPUTER SYSTEM

MANUFACTURING METHODS AND TECHNOLOGY
PROJECT SUMMARY REPORT
(RCS DRCMT-302)

Manufacturing Methods and Technology Project 278 9773 titled, "MM&T Computer Program Aid for Preparation of Automatic Analog Circuit Production Test Programs," was completed by the US Army Communications Research and Development Command in December 1980 at a cost of \$500,000.

BACKGROUND

This effort was undertaken to reduce the amount of direct labor required to prepare and validate programs used with Automatic Test Equipment (ATE) in the testing of analog circuits. The need became apparent during the application of Electronic Quality Assurance Test Equipment (EQUATE) to Army radios. Test Program Sets were generated using a team of experts in circuit design, applied mathematics and the test language Abbreviated Test Language for All Systems (ATLAS). Computer aides for test program preparation had been proven in the field of digital circuits. Successful work in the analog circuit field had been done by industry on a limited scale to satisfy specific needs. Prior efforts also involved MMT Project 276 9773 titled, "MMT - Computer Program Aid for Preparation of Automatic Analog Circuit Production Test Program."

Under this prior MMT Project, ATLAS Test Program Generator I (AGEN I) was developed and demonstrated for a sample amplifier. AGEN I is an interactive test program which requires only test specifications from the user to complete the program generation. AGEN I was demonstrated on Versatile Avionic Shop Tester (VAST).

SUMMARY

The objective of this project was to reduce the direct labor costs for the preparation of ATE test programs for linear analog circuits. The five basic analog Units Under Test (UUT's) considered were analog amplifiers, oscillators, power supplies, mixers and filters. The approach used was to extend the capability of the previously developed AGEN I system. The extension to AGEN II expanded the capability of AGEN horizontally (adding more analog networks to AGEN) and vertically (adding more characteristics to an analog network). AGEN was converted from using VAST to using the Army's EQUATE Test Station (AN/USM-410). The AGEN II System was implemented in Fortran IV on a UNIVAC 1108 under the EXEC III Operating System. A result of this effort was the demonstration of an Integrated AGEN II Test System.

The ATLAS Source Program Library, the AGEN II Executive Software System, and the EQUATE Test Station are the three major elements comprising the integrated AGEN II test system. The ATLAS Source Program Library stores all the ATLAS test program skeletons in source form and supplies to the AGEN II System for program generation. The AGEN II Executive Software System generates ATLAS source test programs free of syntactic, semantic, and engineering errors

for functional testing of analog circuits on the EQUATE Test Station. The EQUATE Test Station compiles the ATLAS Source Test Programs generated by AGEN II and tests the UUT. The Integrated Test System with Communication Link is illustrated in Figure 1. With the communication link (Figure 1) the Data General NOVA 3/Eclipse minicomputer which controls the EQUATE Test Station is linked to a UNIVAC 1108 installation, where the AGEN II Software System resides.

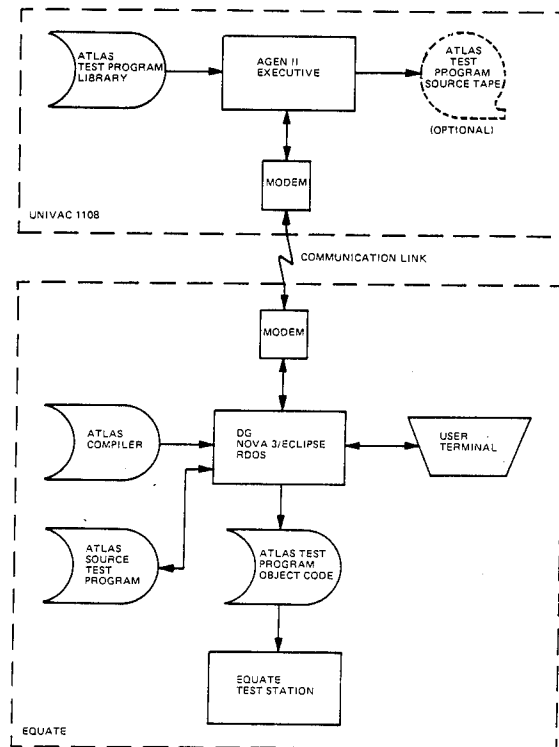

Figure 1 - The Integrated Test System with Communication Link

BENEFITS

The ATLAS test programs for simple linear analog circuits can be generated in a brief interactive session between the user and the AGEN II Software Program. The user of the system will not be required to write network equations or possess any knowledge of computer programming to operate the system. The user input is readily available numerical engineering test data, which obviates the need for expertise in any specific ATE programming language. The system performs the functional testing of simple analog circuits. It is estimated that the time required to develop a test program for one of the five circuits can be reduced by 70% using AGEN II.

IMPLEMENTATION

A demonstration at Tobyhanna Army Depot verified that AGEN II should be extended to include additional capability. Diagnostics on more complex circuits, simulation of complex analog networks, and automatic fault isolation were identified as additional enhancements needed to improve AGEN II usability.

MORE INFORMATION

Additional information on this effort is available in a three-volume Technical Report titled, "ATLAS Test Program Generator II (AGEN II); Executive Software System - Volume I; User's Guide - Volume II; Software Modules Listing - Volume III" dated August 1980, Contract Number DAAB07-78-C-2015. The project officer is Mr. Roy Zelinka, CECOM, DRDCO-TCS-MS, AV 992-5266 or Commercial (201) 532-5266.

Summary Report was prepared by Stephen McGlone, Manufacturing Technology Division, US Army Industrial Base Engineering Activity, Rock Island, IL 61299.

MANUFACTURING METHODS AND TECHNOLOGY
PROJECT SUMMARY REPORT
(RCS DRCMT-302)

Manufacturing Methods and Technology Project 574 4500 titled, "Modernized Testing Technology Providing for Immediate Data Acquisition, Reduction, and Dissemination, CAM Related," was completed by the US Army Armament Command in February 1976 at a cost of \$450,000.

BACKGROUND

Prior to this effort, instrumentation for ballistic testing of nuclear munitions consisted of fitting telemetry units to samples of each production quantity. The variables data (analog signals) obtained were recorded on oscillograph recorders. Analysis of these paper traces included chart measuring, hand calculating, table reading, and the use of calculators and digitizers. Analysis of radar coverage of conventional ammunition was similarly constrained. This effort was undertaken to reduce costs and improve the timeliness and reliability of the ballistic test data.

A Data Acquisition Support System (DASS) was designed and a limited capability was demonstrated under a prior effort, MMT Project 573 4500.

SUMMARY

The objective of this effort was to reduce the cost and delays associated with the reduction and analysis of test data. The approach was to design and develop digital computer systems with data acquisition and data reduction capabilities. The telemetry support sub-system was designed and installed with limited capability and is illustrated in Figure 1.

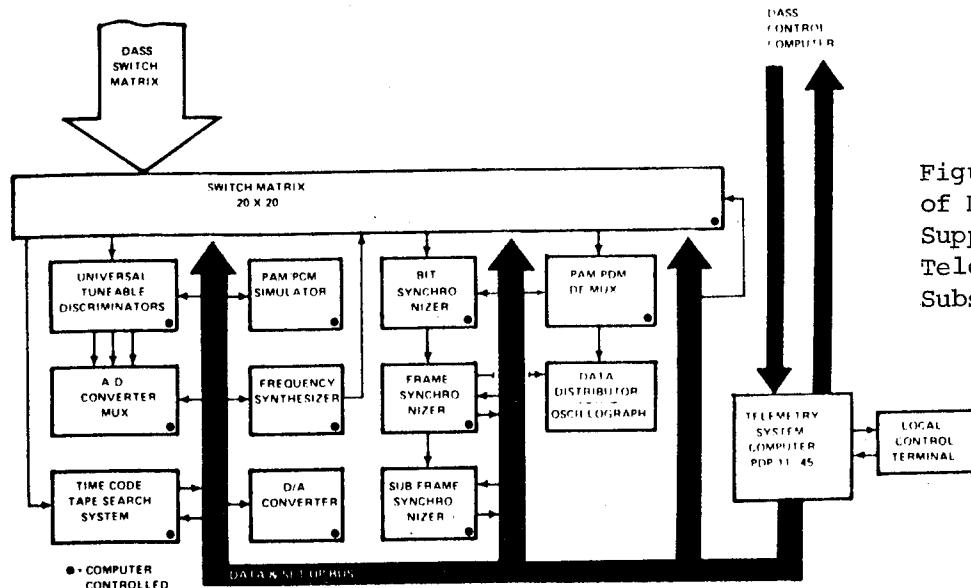

Figure 1 - Flow Chart of Data Acquisition Support System and Telemetry Support Subsystem

A significant achievement in data reduction techniques was developed. Spin, nutation rate, and precision rate of unmodified projectiles throughout flight was obtained using standard radar data. Differences in testing methodology were discovered. Recommendations were made for standardization of testing methodology at Army Proving Grounds.

Computer programs were written to process velocity, acceleration, displacement, vibration, acoustic pressure, temperature, infrared, laser and aeroballistic data. An example of analysis using these programs was the trajectory determination using pulsed and Doppler radar. This method is passive in nature (does not require any change to the projectile) and allows for after-the-fact signal processing. Radar can now be used during acceptance testing and requires no change in testing operation. Also, more test information is now available.

By interfacing a hardware Fast Fourier Transform processor to the DASS, velocity time and amplitude traces such as those illustrated in Figure 2 were routinely obtained.

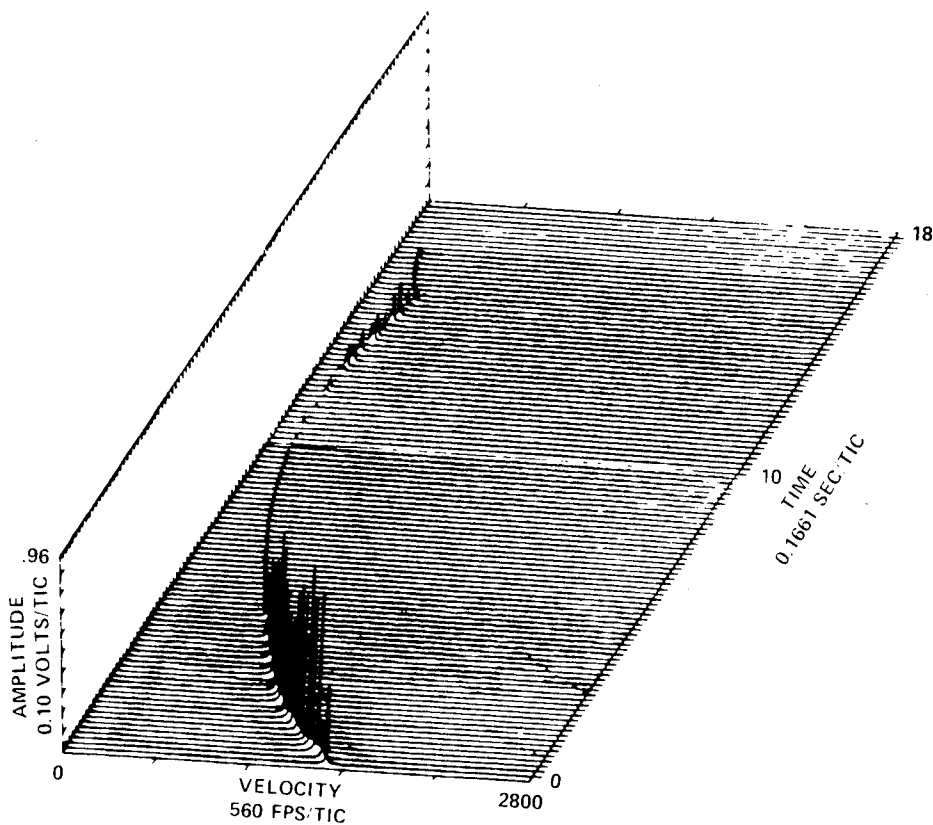

Figure 2 - Radar Analysis of Flight of XM726 Projectile

BENEFITS

The analysis of radar returns has been enhanced to provide non-subjective and rapid data. It is now possible to obtain the entire flight history of a projectile as a function of time throughout its trajectory. Projectile data analyzed included velocity, range, spin rate, nutation rate, precision rate, position, and hardware security (external parts failure).

IMPLEMENTATION

Based on the results of this project, coordination meetings were held to standardize test methodologies within the US Army Materiel Development and Readiness Command. The results of this project were applied to Manufacturing Methods and Technology Project 575 4500.

MORE INFORMATION

Additional information can be obtained in a technical report titled, "Computer Aided Testing Technology and Signal Processing," December 1980. The Defense Technical Information Center number for this report is ADB 053296. The project officer is Mr. Leonard Goldsmith, US Army Armament Research and Development Command, AV 880-3357, or Commercial (201) 328-4951.

Summary Report was prepared by Stephen McGlone, Manufacturing Technology Division, US Army Industrial Base Engineering Activity, Rock Island, IL 61299.

MANUFACTURING METHODS AND TECHNOLOGY
PROJECT SUMMARY REPORT
(RCS DRCMT-302)

Manufacturing Methods and Technology Project 575 4500 titled, "Modernized Testing Technology Providing for Immediate Data Acquisition, Reduction and Dissemination, CAM Related," was completed by the US Army Armament Command in August 1976 at a cost of \$190,000.

BACKGROUND

Prior to this effort, instrumentation for ballistic testing of nuclear munitions consisted of fitting telemetry units to samples of each production quantity. The variables data (analog signals) obtained were recorded on oscillograph recorders. Analysis of these paper traces included chart measuring, hand calculating, table reading and the use of calculators and digitizers. This method was time consuming, error prone, and required a highly skilled professional. Analysis of the radar coverage of conventional ammunition was similarly constrained. This effort was undertaken to reduce costs and improve the timeliness and reliability of the analysis of ballistic test data.

A Data Acquisition Support System (DASS) and Telemetry Support System were designed and demonstrated with limited capability under prior efforts, MMT Projects 573 4500 and 574 4500.

SUMMARY

The objective of this effort was to reduce the cost and delays associated with the reduction and analysis of test data. The approach was to design and develop digital computer systems with data acquisition and data reduction capabilities.

A new technique for the reduction of Yaw Sonde Transducer Data was developed. The enhancements to the system enabled the detection of payload deficiencies which were causing the ballistic instability of an artillery projectile. Through the use of digital signal processing technology, data was manipulated to extract the signal from background electronic noise. The developments of the processing of Yaw Sonde outputs of modified munitions items provides projectile flight data heretofore unobtainable. The processing techniques provide clean data in most instances where weak signals exist. Therefore, the true in-flight performance of the projectiles was obtained as a function of time.

Progress was realized on the utilization of the system for the acquisition and feedback of test data to the engineer at the test location. The use of cables and microwave networks for the digital transmission of test data at high rates was demonstrated at Army proving grounds. The microwave transmission network is illustrated in Figure 1. The information transmitted via the microwave link is raw test data from the test location to the central acquisition site.

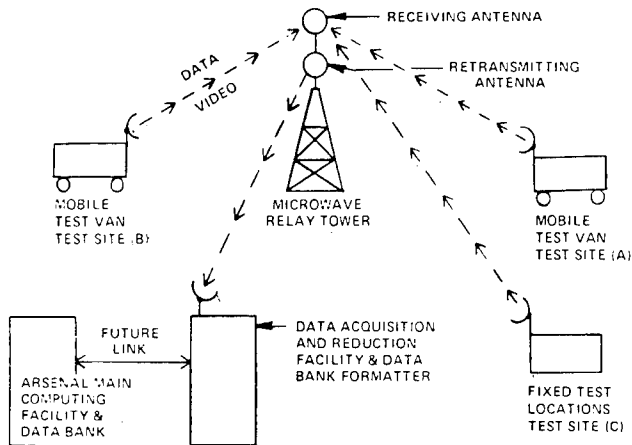

Figure 1 - Test Data Acquisition Microwave Communication Link

BENEFITS

The rapid analysis of an item's flight characteristics allows for the early detection of a defective sample from a production lot. Difficulties encountered in the flight of each item fired can be determined.

Testing cost reduction is anticipated through consolidated and reduced instrumentation, manpower, and number of units tested.

Non-Quantifiable Benefits are planned to be achieved through:

1. Ability to monitor and control testing.
2. Calibration and on-line monitoring of test performance.
3. Back-up test documentation in case of system failure.
4. Objective test information for data storage, retrieval and analysis.
5. Automated method for reduction of recorded media analog data.
6. Modularity for system maintenance.
7. Traceability and standardization of data reduction.

IMPLEMENTATION

Based on the results of this effort, coordination meetings were held within the US Army Materiel Development and Readiness Command on instrumentation and testing technology. Work is now in progress to more precisely define testing criteria and reporting nomenclature.

ADDITIONAL INFORMATION

More information can be obtained in a technical report titled, "Computer Aided Testing Technology and Signal Processing", Dec 80. The Defense Technical Information Center number for this report is ADB 053296. The project officer is Mr. Leonard Goldsmith, ARRADCOM, AV 880-3357 or Commercial (201) 328-4955.

Summary Report was prepared by Stephen McGlone, Manufacturing Technology Division, US Army Industrial Base Engineering Activity, Rock Island, IL 61299.

MANUFACTURING METHODS AND TECHNOLOGY
PROJECT SUMMARY REPORT
(RCS DRCMT-302)

Manufacturing Methods and Technology Project 576 4500 titled, "Modernized Testing Technology Providing for Immediate Data Acquisition, Reduction and Dissemination, CAM Related," was completed by the US Army Armament Research and Development Command in May 1978 at a cost of \$188,000.

BACKGROUND

Prior to this effort, instrumentation for ballistic testing of nuclear munitions consisted of fitting telemetry units to samples of each production quantity. The variables data (analog signals) obtained were recorded on oscillograph recorders. Analysis of these paper traces included chart measuring, hand calculating, table reading and the use of calculators and digitizers. This method was time consuming, error prone, and required a highly skilled professional. Analysis of radar coverage of conventional ammunition was similarly constrained. This effort was undertaken to reduce costs and improve the timeliness and reliability of the analysis of ballistic test data.

A Data Acquisition Support System (DASS) and a Telemetry Support System were designed and demonstrated under prior efforts. Techniques for radar analysis of unmodified items and Yaw Sonde analysis of modified items were also developed. The use of cables and a microwave network for the digital transmission of test data was demonstrated at high transmission rates. The prior efforts were Manufacturing Methods and Technology Projects 573 4500, 574 4500 and 575 4500 with the same title as above.

SUMMARY

The objective of this effort was to reduce the cost and delays associated with the reduction and analysis of test data. The approach was to design and develop digital computer systems with data acquisition and data reduction capabilities. Two systems were developed, one evolving from the other, for the acquisition of test data. System I (DASS) transmits analog data to a central site. System II - Test Module System (TMS), a DASS augmentation, digitizes test data on site and transmits digital data to the central site for processing, see Figure 1.

A front end system (TMS) was developed to acquire data that is short in duration (less than 50 milliseconds) and of high frequency content (200 kHz). The TMS acts totally as an acquisition device and depends on the remote large-scale computer system DASS to provide processing. Each analog to digital converter can store 16,000 samples at rates up to 500 kHz per channel. After transmission to the central computing system, the data is processed on an existing stored program in DASS. The data is analyzed and graphically displayed at the central site and then transmitted to the test site for local graphical display. Storage capability (cartridge or disc) is present at the test site for data storage or graphical display.

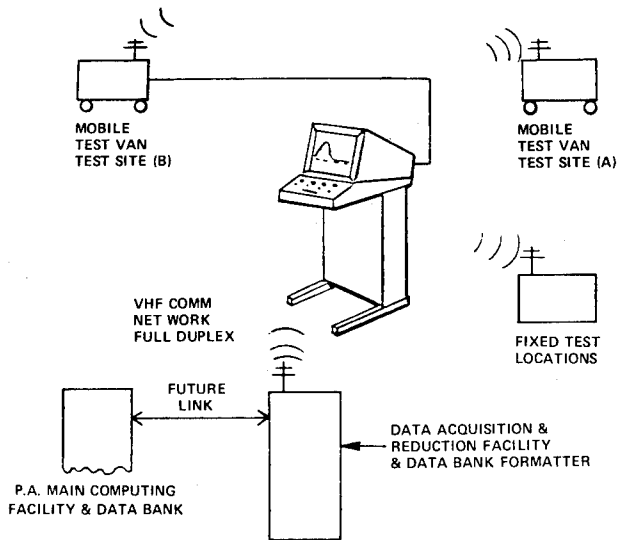

Figure 1 - Data Acquisition Support System Augmentation Test Module System

BENEFITS

The TMS serves the purpose of removing from the test site substantial amounts of reasonably expensive test and instrumentation equipment for collecting and storing the data being generated by the test. Therefore, test equipment costs are reduced.

In addition to reducing test site instrumentation costs, the TMS provides resolution and accuracy at least one order of magnitude better than previously existed.

IMPLEMENTATION

Some of the results from this project have been implemented at the testing facilities within the Armament Research and Development Command. In addition, implementation of the results of this project is in progress through the Test and Evaluation Command and several Army Proving Grounds; for example, Aberdeen Proving Ground, Aberdeen, MD.

ADDITIONAL INFORMATION

More information can be obtained in a technical report titled, "Computer Aided Testing Technology and Signal Processing," December 1980. The Defense Technical Information Center number for this report is ADB 053296.

The project officer is Mr. Leonard Goldsmith, US Army Armament Research and Development Command, AV 880-3357 or Commercial (201) 328-4955.

Summary Report was prepared by Stephen McGlone, Manufacturing Technology Division, US Army Industrial Base Engineering Activity, Rock Island, IL 61299.

MANUFACTURING METHODS AND TECHNOLOGY
PROJECT SUMMARY REPORT
(RCS DRCMT-302)

Manufacturing Methods and Technology Project 679 8104 titled, "Improved Breech Mechanism Manufacturing" was completed by the US Army Armament Material Readiness Command in July 1980 at a cost of \$40,000.

BACKGROUND

Mass production techniques are normally not used to manufacture parts and components for weapon systems since requirements for the systems are insufficient to amortize highly specialized automated equipment. Thus, the cost of the systems are relatively high. The concept of flexible manufacturing systems (FMS) offers the economics of mass production to mid-volume manufacturing. Through the integration of work stations, material handling equipment and computer control, a family of similar parts can be manufactured with minimum direct labor.

The intent of this project was to investigate the complete breech block manufacturing cycle at Watervliet Arsenal and fabricate a computerized breech block manufacturing cell. After preliminary investigation, it was decided that a FMS architecture was the most compatible design with Watervliet's requirements.

SUMMARY

The objective of this project was to perform an industry analysis and then develop a scope of work with performance specifications to support the purchase of a FMS for Watervliet Arsenal. A major industry survey of machine tool builders, with experience in FMS, was conducted. Technologies currently available were identified and compared with Watervliet's requirements. Upon completion of this initial information gathering phase, parts and components were evaluated to determine the appropriate equipment configuration.

A family of breech mechanisms was chosen with requirements for the 105mm M68, 120mm XM256, and 155mm M185, sufficient to workload the FMS. Process planning data was assembled and a ten-part procurement plan was outlined. Watervliet chose to use a combination of a "turn-key" and "definitive" purchase agreement whereby responsibilities are distributed between the vendor and user.

A presolicitation conference was held on 23 September 1980. A request for concept proposal was issued along with evaluation criteria.

BENEFITS

A flexible manufacturing system will provide Watervliet Arsenal with the capability to capitalize on the economics of mass production while minimizing

the risk associated with dedicated equipment. In addition, in-process inventory and manufacturing lead times for selected parts will be reduced.

IMPLEMENTATION

Negotiations to purchase a flexible manufacturing system are in process.

MORE INFORMATION

Additional information is available from Mr. Alex Wakulenko, Watervliet Arsenal, AV 974-5611 or Commercial (518) 266-5719.

Summary Report was prepared by Jim Sullivan, Manufacturing Technology Division, US Army Industrial Base Engineering Activity, Rock Island, IL 61299.

ELECTRONICS

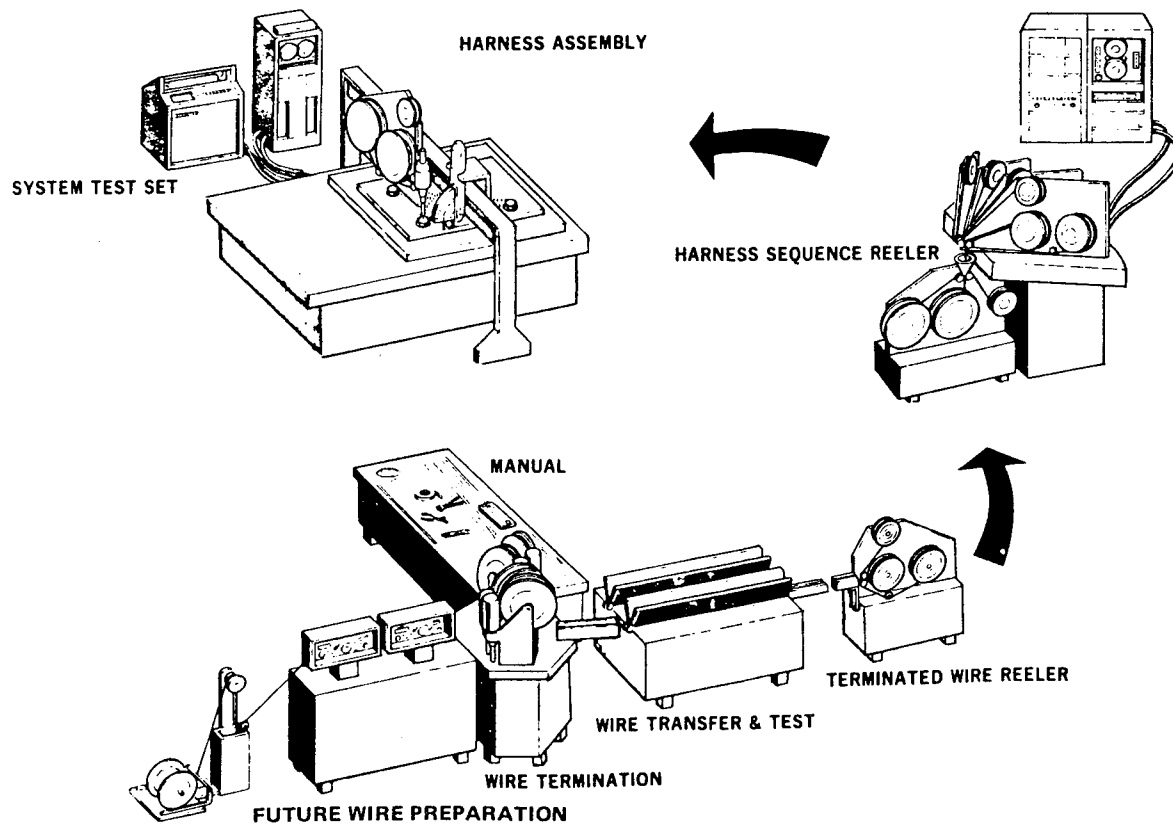

CONCEPTUAL APPROACH TO FIXING
ELECTRICAL CONNECTORS TO CABLES

MANUFACTURING METHODS AND TECHNOLOGY
PROJECT SUMMARY REPORT
(RCS DRCMT-302)

Manufacturing Methods and Technology Project 272 9359 titled, "MM&T - Integrated Circuit Power Amplifier for Tactical Radio Equipment," was completed by the US Army Electronics Command in January 1978 at a cost of \$200,000.

BACKGROUND

At the time of contract award, 30 watt Integrated Circuit (IC) power amplifiers in the 600-1000 MHz bandwidth were needed for various military communications equipments. The objective was to develop an IC device which could be adapted as a building block for higher power systems.

The design selected used the TRW microamp broadband SB2000 transistor which was optimized as part of the effort. Two 18 watt amplifiers were combined using an interdigitated quadrature hybrid combiner to achieve the required minimum power. The hybrid combiner was designed in microstrip configuration and fabricated simultaneously with the microstrip matching networks, thus facilitating batch processing. The combiner also provided isolation between the two amplifiers and operated over a full octave bandwidth.

SUMMARY

The project's objective was to establish a production capability for reliable IC broadband VHF power amplifiers. TRW Semiconductors, Lawndale, CA, performed the work which involved optimizing transistor design, constructing a power splitter/combiner and a suitable substrate interconnection pattern and package.

Low cost amplifier production depends on the ability to produce broadband transistors and matching circuits that require little or no tuning. The internal matching network was incorporated in the transistor package and optimized for the 600-1000 MHz operating bandwidth to facilitate broadbanding. The input and load matching networks were computer designed for maximum power transfer into and out of the SB5000 transistor chip.

The power splitter/combiner and the external matching networks were batch fabricated using microstrip on a single 2 x 2 inch alumina substrate. This required that a three layer mask set be generated to permit etching of a gold plated metal pattern, a sputtered gold metal pattern and a sputtered cermet metal pattern. The gold plated metal pattern defined the matching circuitry, the DC feed network and the quadrature combiners.

The sputtered gold metal pattern delineated the termination series resistors, and the sputtered cermet metal pattern defined the termination shunt resistors.

Techniques for assembling the amplifier and hermetically solder sealing the package were developed. A package gross leak detection test was performed at 25 psi internal pressure.

These several techniques were successfully demonstrated by building 50 amplifiers on a pilot line within the five working days allotted. All amplifiers were electrically RF tested for power in, power out, relative phase, current drain, efficiency and VSWR. The complete amplifier is shown in Figure 1.

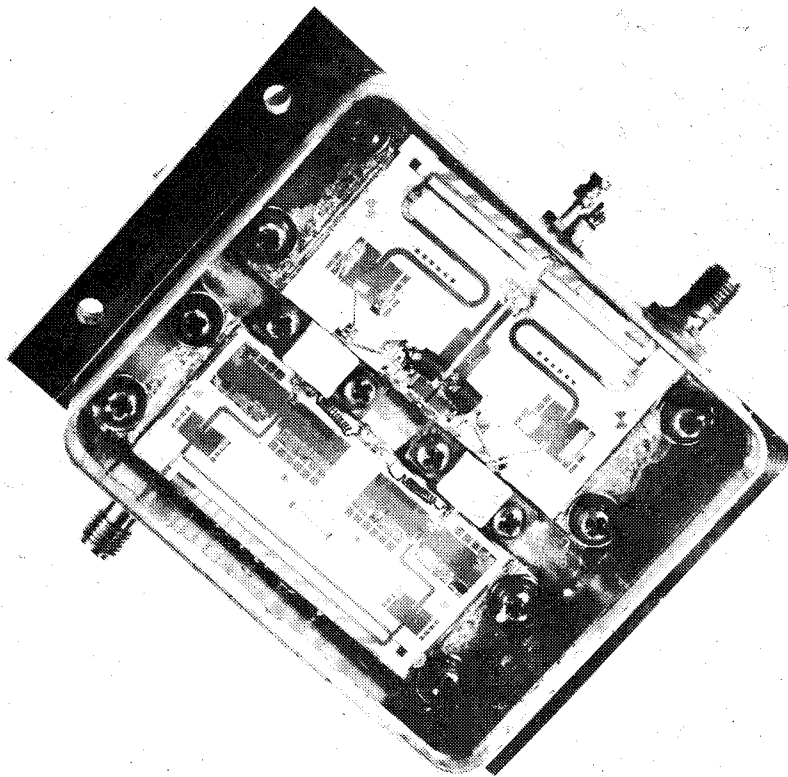

Figure 1 - 30 Watt IC Broadband UHF Power Amplifier

BENEFITS

As a result of this effort a production capability for broadband UHF power module amplifiers now exists. These modules can be combined to achieve significantly higher power levels.

Amplifier cost at the time of contract completion was approximately \$500 each.

IMPLEMENTATION

The power amplifier modules produced on this project were originally scheduled for use in the AN/GRC-103 Tactical Radio, but were not implemented due to a change in requirements.

The processes developed, however, are applicable to other UHF circuits. These techniques were documented in a final report which was distributed to both industry and government.

MORE INFORMATION

Additional information may be obtained from Mr. Russell Gilson, ERADCOM, AV 995-4917 or Commercial (201) 544-4917. The contract was DAABO5-72-C-5844.

Summary Report was prepared by Stephen C. Yedinak, Manufacturing Technology Division, US Army Industrial Base Engineering Activity, Rock Island, IL 61299.

MANUFACTURING METHODS AND TECHNOLOGY
PROJECT SUMMARY REPORT
(RCS DRCMT-302)

Manufacturing Methods and Technology Project 272 9379 titled, "Low Noise Solid State Local Oscillator," was completed by the US Army Electronics Command in June 1976 at a cost of \$141,000.

BACKGROUND

Local oscillators used in portable radars and microwave communications equipment generate both AM and FM noise which limits system range and performance. It was determined that Ku and X-Band devices could be improved by optimizing and controlling the bulk semiconductor material, the internal structure of the oscillator, and the operating cavity. Techniques for fabricating solid state devices on a production basis were needed.

The oscillators were planned using a high-quality sealed-design in order to maintain good frequency stability over a wide temperature range. The diode source was made mechanically tunable and electronic tuning was provided for Automatic Frequency Control (AFC) by a varactor diode.

SUMMARY

Microwave Associates at Burlington, MA, established the manufacturing methods, tolerances, materials, jigs and special test equipment for low-noise solid state Ku and X-Band local oscillators.

The oscillator source initially selected was a gallium arsenide (GaAs) IMPATT diode. This transferred electron device operated in the dynamic negative resistance region (avalanche) and was mounted in a high "Q" waveguide cavity. IMPATT diodes were fabricated and met all technical specifications, including noise levels, but failed to achieve the necessary yields. Subsequently, the contract was modified to use GaAs Gunn diodes which met both technical specification and noise requirements.

The work scope was separated into two parallel tasks: GaAs Gunn diode fabrication and oscillator development and packaging.

Gunn diode fabrication processes included GaAs epitaxial growth, lapping, chemical etching, gold plating metallization, and palladium sintering in a diffused hydrogen atmosphere. Wafer processing steps are outlined in Figure 1. The wafer was scribed into chips which were thermocompression bonded, mesa side down, into a standard package. The package was hermetically sealed in dry nitrogen.

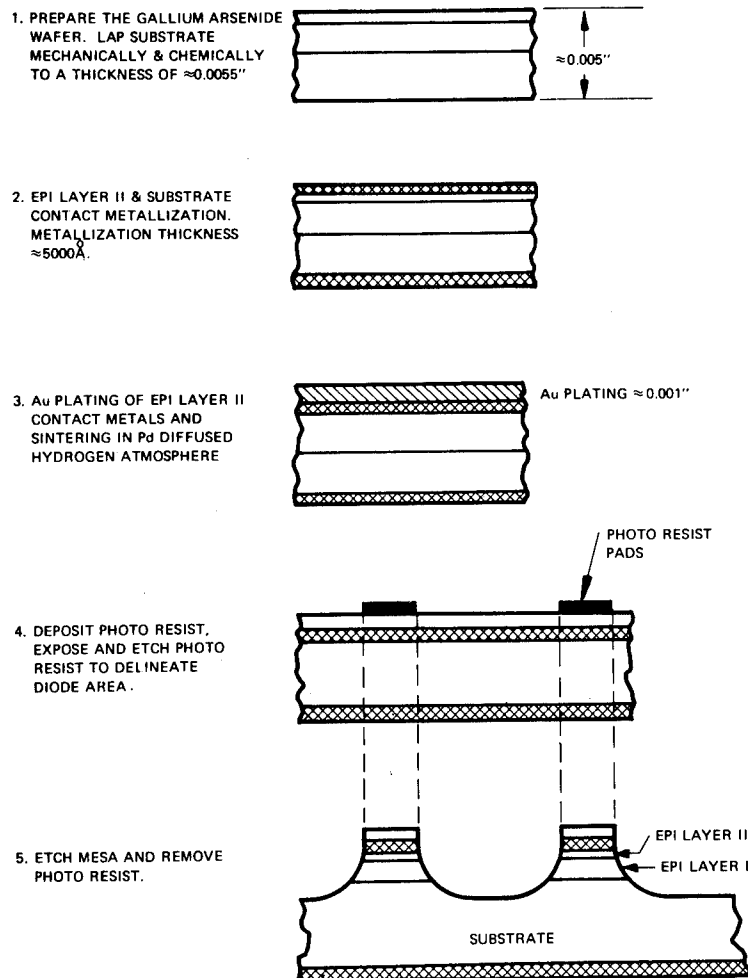

Figure 1 - Outline of Processing Steps In Gunn Diode Fabrication

The oscillator, Figure 2, was designed using a basic half-wavelength cavity which was iris-coupled to the external load. The iris could be readily adjusted to control the loaded "Q" which would not exceed a specific value at mid-band. Both GaAs Gunn avalanche diodes and silicon varactor diodes were mounted on posts in the cavity. Post diameters and positions were determined to provide the requisite coupling between each diode and the cavity.

The oscillator body was constructed of two machined copper blocks brazed together. Three turrets, housing bias feedthroughs and the tuning mechanism, were also brazed onto the body. The design was adapted for finish machining after brazing. A fixture was built to permit single step brazing. The cavity length was machined as were seats for the iris, pressure window, Gunn diode and varactor diode bias leads. The unit was hermetically sealed with O-rings.

Some diode burn-outs occurred which were associated with improper bias lead insulation and bias-lead choke optimization. This was corrected by a fixed, double choke design.

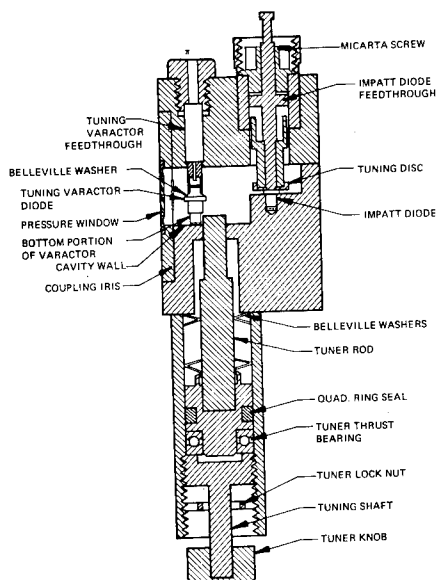

Figure 2 -
Oscillator Cross Section

Electrical tests performed on completed units included RF output power, DC input power, VSWR, AM Noise SSB, FM noise SSB, and mechanical and electronic tuning. The contractor demonstrated the technology by assembling a pilot line and building 14 Ku-band and 30 X-band oscillators at the required rate of 40 per month.

BENEFITS

Significant improvements in oscillator cost and production capability are listed below. These are the savings that would be realized in a fully implemented production facility:

	<u>Cost Before MMT</u>	<u>Cost After MMT</u>
Ku-band	\$350	\$142
X-band	\$100	\$ 52
	<u>Production Capability Before MMT</u>	<u>Production Capability After MMT</u>
Ku-band	None	400/month
X-band	100	1000/month

IMPLEMENTATION

The Ku-band oscillator is presently in the AN/PPS-5 Radar. The X-band oscillator is used in several commercial systems including aircraft (Boeing 747) radar, small boat radar, and weather radar.

MORE INFORMATION

Additional information may be obtained from Mr. L. C. Nelson, Microwave Association, Burlington, MA, Commercial (617) 272-1931. The contract was DAAB05-72-C-5861.

MANUFACTURING METHODS AND TECHNOLOGY
PROJECT SUMMARY REPORT
(RCS DRCMT-302)

Manufacturing Methods and Technology Project 275 9441 titled, "Arc Plasma Sprayed Phase Shift Elements," was completed by the US Army Electronics Research and Development Command in July 1978 at a cost of \$280,000.

BACKGROUND

The phased array radar antenna is a well established device capable of search and multi-target tracking operations in a military environment. Each antenna array incorporates thousands of radiating elements, and each element contains a ferrite phase shifter. Therefore, it was important to develop manufacturing methods to produce these shifters at a minimal cost.

A phase shifter is composed of a long toroidal ferrite element enveloping a dielectric core. The conventional method of fabrication involves firing and machining the ferrite torroid, coating the dielectric with resin, and inserting it into the torroid. High cost is incurred in the manufacture of tight-fitting components, and the resin material introduces a void that degrades the performance of the radar. An alternative to the conventional method employs the arc plasma spraying (APS) technique, a well-established process for depositing a tough, temperature-insensitive coating onto a metal core. The APS method had been used to spray ferrite onto a dielectric core, but manufacturing techniques were yet to be defined.

SUMMARY

The objective of this project was to establish the arc plasma spraying technique as a production method in the fabrication of C-band ferrite phase shifters. The work was contracted to Raytheon at Waltham, MA, and is a follow-up to Project 273 9696, titled, "Manufacturing Methods for the Production of Microwave Ferrite Powders." Previous research had identified the critical parameters and refined the APS technique specifically for ferrite powders. Subsequent effort focused on establishing the optimum characteristics of ferrite powders for the production of shifter elements. The present project applied this knowledge to the manufacture of phase shifter elements.

In the APS process, ferrite powder is partially melted by an intense plasma field and deposited at high temperature onto a dielectric core in a fine, dense layer, Figure 1. To develop a manufacturing method, Raytheon examined properties of ferrite powders and various dielectrics while initiating design of the APS production equipment. Following guidelines established by earlier R&D, a lithium ferrite compound was chosen for its suitable magnetic properties. The powder was spray dried to achieve a spherical shape and a particle size of 30 microns. The dielectric material was selected for compatibility with the ferrite in both its crystal structure and thermal expansion rate. The final design of the spraying equipment included a second oven to

facilitate a post anneal of the sprayed elements. To provide a uniform coat on the substrate, hydraulic translation and d-c motor rotation equipment was included.

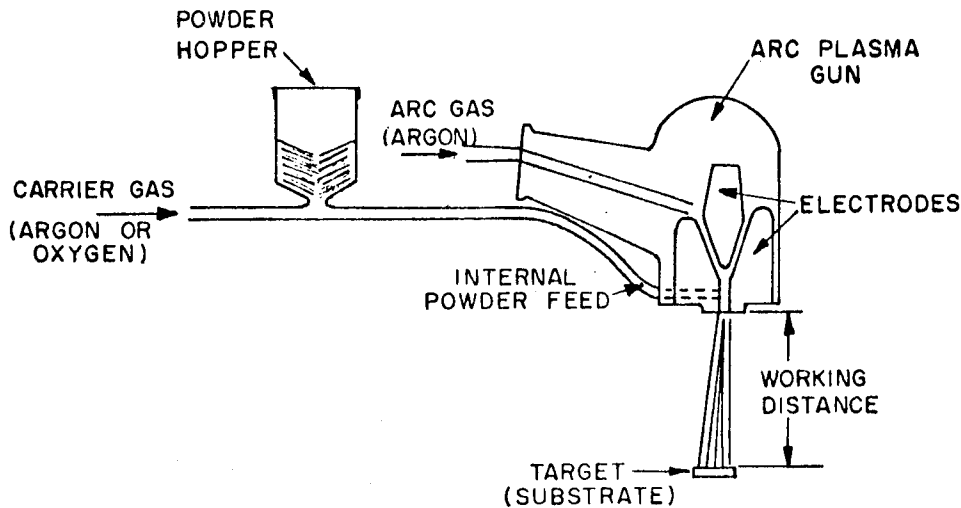

Figure 1 - Arc Plasma Deposition Technique

After encountering serious difficulties with cracking of the ferrite and non-uniform magnetic properties, a powder was chosen which yielded satisfactory results. The arc plasma spray unit regularly produced ferrite elements at a rate of five per hour. Unfortunately, the method suffered from poor reproducibility and high cost. One problem was the high variability in the insertion phase angle, about 2.5 times the desired level. Another problem was the larger coercive (H_c) force in the APS samples. This implied the need for a higher energy drive circuit. But the most serious drawback was the high unit cost of \$63 per boule. This is approximately three times higher than the cost of the conventional process.

BENEFITS

The APS process has proven to be an effective technique in the fabrication of ferrite phase shifters. However, for greater reproducibility and cost reduction, improved ferrite powders need to be developed. A possible application of this MMT effort is in millimeter wavelength phase shifters which operate under much less stringent specifications.

IMPLEMENTATION

It was not economically feasible to fabricate C-band ferrite phase shifters with this APS process due to low yield and high unit cost. However,

an R&D effort is underway to develop this technology for the less-demanding millimeter wavelength applications.

MORE INFORMATION

Additional information may be obtained from Mr. Richard Babbitt, ERADCOM, Ft. Monmouth, NJ, AV 995-2284 or Commercial (201) 544-2284. The contract was DAAB07-75-6-0043.

Summary Report was prepared by Charles Miller, Manufacturing Technology Division, US Army Industrial Base Engineering Activity, Rock Island, IL 61299.

MANUFACTURING METHODS AND TECHNOLOGY
PROJECT SUMMARY REPORT
(RCS DRCMT-302)

Manufacturing Methods and Technology Project 275 9836 titled, "Establishment of Quality Control Techniques for Fabrication of 18mm and 25mm Etched Core Microchannel Plates," was completed by the US Army Electronics Research and Development Command in June 1978 at a cost of \$276,000.

BACKGROUND

A microchannel plate (MCP) is a high speed electron multiplier (amplifier) constructed of a glass channel array which accelerates electrons emitted by a photocathode. The device is a critical component of 18mm and 25mm image intensifier tubes used in night vision devices.

Microchannel plates are made in sequential operations which include fiber and boule fabrication, optical finishing, chemical etching, electroding and testing. A total quality program to assure reliable products existed at various tube manufacturers, but it was impractical for microchannel plates. Efforts were needed to improve the quality and increase yield for this component.

SUMMARY

The project's objective was to develop, document and implement a quality control system for all phases of MCP production which would meet the criteria set forth in MIL-Q-9858A. The work was performed by Varian Associates, Palo Alto, CA. Significant accomplishments were the following:

1. Optimized the Q.A. Organizational Structure.
2. Issued QA policy and operating manuals.
3. Developed Standard Process Procedures for all processes used in fabricating MCPs.
4. Set up techniques for drawing and change control, and equipment calibration and maintenance procedures.
5. Fabricated special jigs and fixtures for in-process inspection.
6. Provided device traceability through each process station.

The quality of the processing stations shown in Figure 1 was verified by obtaining data on units built on a pilot line. MCP device quality and yields were significantly improved. The results are tabulated for the 18mm MCP in Figure 1 and for the 25mm MCP in Figure 2.

BENEFITS

As a result of this effort, a \$100 cost reduction per MCP is anticipated. Estimated savings from 1978-1983 is expected to be \$2.45 million.

YIELD BY STATION - 18mm

Station Title	Yield Prod. Line Oct. 1977	Yield Pilot Run	Expected Process Average	Expected Limits ± %
Plate Rounding	86	100	94	5
Plate Edge and Lapping	89	93	91	3
Plate Polishing	99	96	93	6
Plate Washing	--	--	--	
Chemical Proc.	95	99	95	4
H ₂ Firing	94	98	96	2
Pre-Electroding	71	75	74	6
Electroding	79	89	88	6
Final Electrical Test	91	20	65	10
Final QA Insp. Includes Waivers	82	82	80	6

Figure 1 -
Pilot Line Results -
18mm

YIELD BY STATION - 25mm

Station Title	Yield Prod. Line Oct 1977	Yield Pilot Run Boule 1277	Expected Proc. Average	Expected Limits + %
Plate Rounding	100	100	98	2
Plate Edge and Lapping	88	92	90	2
Plate Polishing	98	98	96	2
Chem Processing	98	100	97	3
H ₂ Firing	90	100	94	3
Pre-Electroding	75	90	81	6
Electroding	74	94	85	4
Final Electrical Test	48	74	75	10
Final QA Insp	56	78	70	10

Figure 2 -
Pilot Line Results -
25mm

IMPLEMENTATION

Varian Associates incorporated this Quality Control system directly into their MCP/Image intensifier tube production facility at Palo Alto, CA. The Quality Control techniques were documented in a Policy Manual and Procedures Manual which were made available to various MCP and tube manufacturers.

MORE INFORMATION

Additional information may be obtained from Dr. K. Villhauer, Night Vision and Electro-optics Laboratory, Fort Belvoir, VA, AV 354-1725 or Commercial (703) 664-6265. The contract was DAAB07-76-C-0046. Summary Report was prepared by Stephen C. Yedinak, Manufacturing Technology Division, US Army Industrial Base Engineering Activity, Rock Island, IL 61299.

MANUFACTURING METHODS AND TECHNOLOGY
PROJECT SUMMARY REPORT
(RCS DRCMT-302)

Manufacturing Methods and Technology Project 276 9754 titled, "MM&T Continuous Cycle Processing of Shock Resistant Quartz Crystal Units," was completed by the US Army Electronics Research & Development Command in January 1980 at a cost of \$826,650.

BACKGROUND

This project was needed to establish production methods for high shock resistant (1000 g) 122 MHz AT-cut quartz crystals. The crystals are required for use in evolving systems such as SINCGARS, SOTAS, GPS, REMBASS and CIS/BIFF. At the time of contract negotiation, no commercial source existed for such devices.

The work was performed at a government owned, contractor operated facility (GOCO), General Electric Neutron Devices, (GEND), a contractor for the US Department of Energy (DOE).

SUMMARY

The project's objective was to build a vacuum system capable of continuous cleaning, baking, plating and sealing high shock resistant, precision, quartz crystals. A production rate goal was 200 units per eight hour shift.

The system was designed with five chambers (entrance, bake, plate, seal, and exit) separated from each other by gate valves. Entrance and exit air lock chambers permit the processing chambers to operate at high vacuum for extended times. The combined vacuum envelope length was optimized at 24 feet.

The entire fabrication facility is shown in Figure 1. A stainless steel conveyor belt, in conjunction with three vacuum manipulators, transports the crystals to various work stations inside the chambers. These stations include: ultraviolet/ozone cleaning, 300°C vacuum baking, coarse and fine gold deposition with automatic frequency plating controls, and gold thermocompression sealing. The chambers and applicable work stations are identified in Figure 2.

A unique gold deposition source was developed for extended operation without reloading. This source emits a narrow 2 1/2 degree cone angle gold beam. Maximum deposition rates are 400 Å^o at a 5.5 inch throw distance.

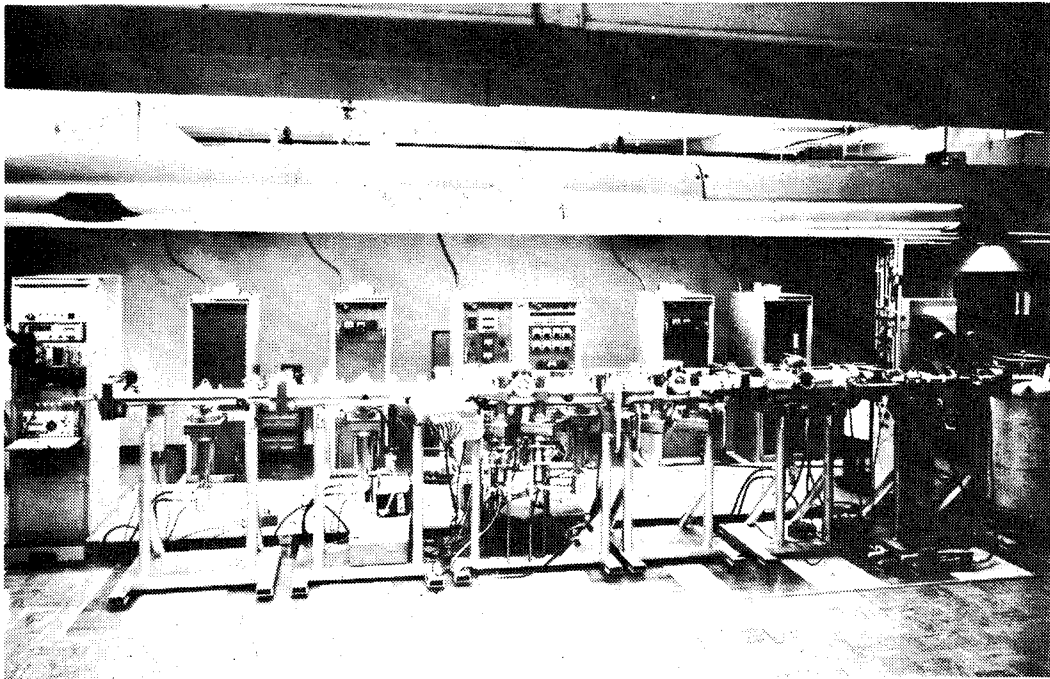

Figure 1 - Quartz Crystal Fabrication Facility, Front View

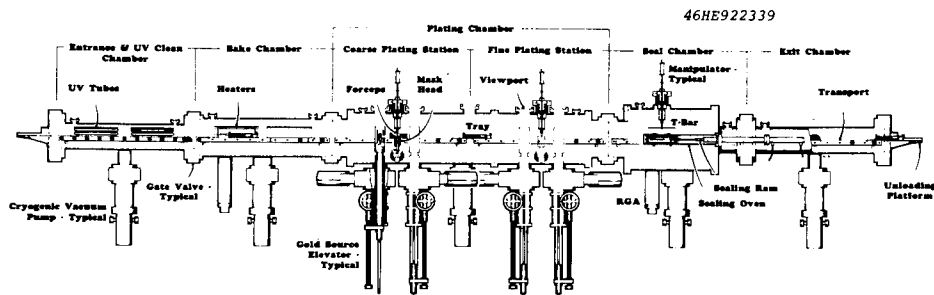

Figure 2 - Quartz Crystal Fabrication Facility, Schematic

The gold source and plating mask heads are equipped with elevators and gate valves so that they can be removed from the system for maintenance without exposing the chamber to the atmosphere. The crystals are mounted in flatpack frames, loaded into transport trays, and sequentially presented to the system.

The equipment utilizes molybdenum disulfide coated ball bearings at almost all friction surfaces. The conveyors are capable of operating at 300°C and 10⁻⁸ Torr. Metal bellows or magnetic drives are utilized to transfer motion into the vacuum chambers.

Each work station was successfully operated at the rate of 15 units per hour. However, the equipment was designed to accommodate larger 25 unit resonator trays which would significantly increase this rate.

Due to the vacuum system's complexity, an integrated test of the entire pilot line will be required to demonstrate actual capacity and operating reliability. This will be accomplished under the phase II effort, project H77 9754, which is currently in progress.

BENEFITS

The contract resulted in a high yield quartz crystal fabrication facility (QXFF) for the most critical steps in fabricating high shock resistant crystals. Prior to this effort, no production capability existed for these precision devices.

IMPLEMENTATION

Follow-on projects for a pilot line at GEND with the above QXFF as the key element are underway. Project H77 9754 (phase II) is establishing the complete pilot line. Project H79 9807 (phase III) will extend the pilot line's capability to 5 MHz and 10 MHz AT-cut quartz crystals required for oven controlled oscillators used in GPS.

MORE INFORMATION

Additional information may be obtained from Dr. John R. Vig, Electronics Technology and Device Laboratory, Ft. Monmouth, NJ, AV 995-4275 or Commercial (201) 544-4275. The contract was HH610964CPW3/01.

Summary Report was prepared by Stephen C. Yedinak, Manufacturing Technology Division, US Army Industrial Base Engineering Activity, Rock Island, IL 61299.

MANUFACTURING METHODS AND TECHNOLOGY
PROJECT SUMMARY REPORT
(RCS DRCMT-302)

Manufacturing Methods and Technology Project 277 9831 titled, "Pilot Manufacture of Rugged L-Band Crystal Controlled Telemetry Transmitter" was completed by the US Army Electronics R&D Command and Harry Diamond Laboratories in September 1979 at a cost of \$79,000.

BACKGROUND

Telemetry transmitters deployed in artillery projectiles transmit flight performance data to test site receivers. Present L-Band transmitters are unstable, bulky and expensive. Survival at high g forces equivalent to being fired in 105mm and 175mm projectiles is required of the complete assembly.

Previous MMT contract work on L-Band telemetry devices on Project H76 3090 was unsuccessful due to initial turn-on frequency instability, limited modulation frequency spectrum, and excessive manufacturing cost.

SUMMARY

This contract's objective was to develop a stable, inexpensive, reproducible L-Band transmitter for telemetering projectile flight performance data. Work was performed by the Applied Physics Laboratory (APL) at Laurel, Maryland, under HDL sponsorship.

APL's approach was to convert the previous contractor's microstrip design into L-Band stripline circuitry. Appropriate circuit modifications were made to minimize tuning adjustment and component selection.

A basic L-Band transmitter consists of an overtone crystal oscillator, a buffer amplifier, a times 2 frequency multiplier, a times 10 frequency multiplier, a filter, and a 1.51 GHz output amplifier. These functions are shown in the block diagram, Figure 1. The transmitter must fit into a cylindrical space 1 1/2 inches in diameter and 1 inch long.

Overcrowding was relieved by repartitioning the circuitry and adding a separate circuit board for the times 2 power amplifier. The crystal oscillator (A1), and times 2 power amplifier (A2) boards were built on DuPont's PYRALIN polyimide material. See Figure 2. The times 10 multiplier and filter, (A3) board and output amplifier (A4) board were fabricated in stripline circuitry using metallic conductors on ceramic substrates. See Figure 3.

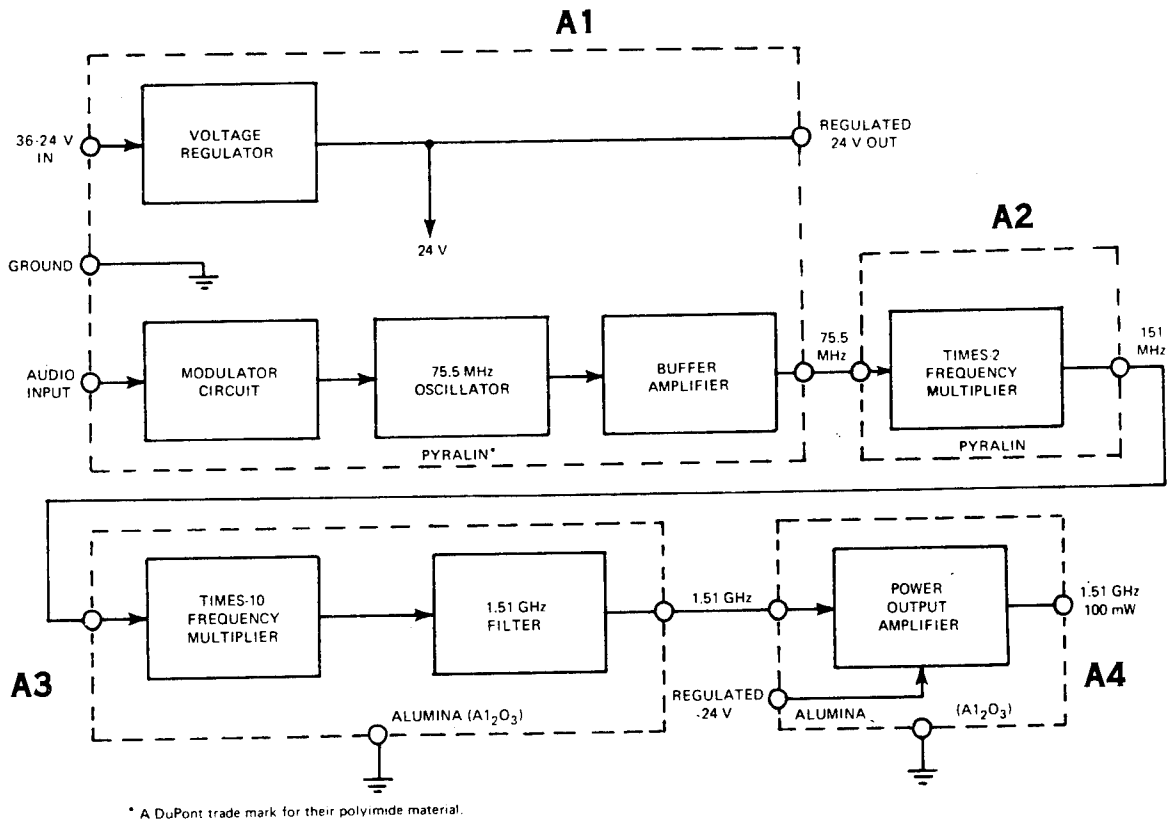

Figure 1 - Block Diagram of L-Band Transmitter

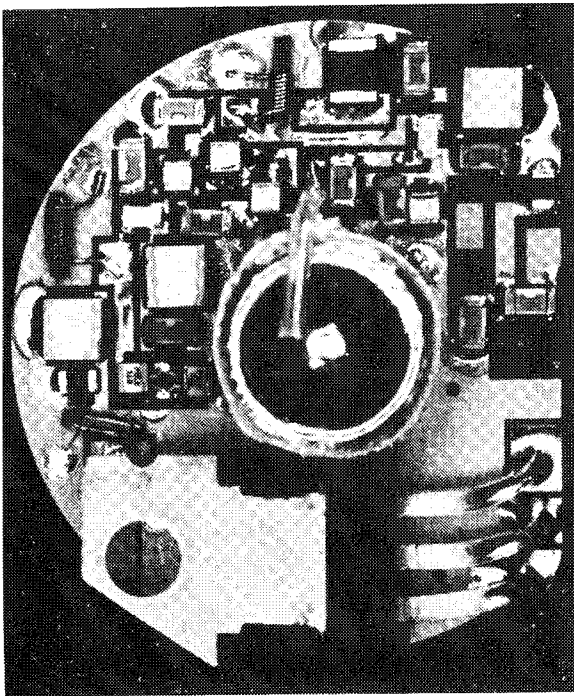

Figure 2 - A1 Board; Modulator, Oscillator, Buffer Amplifier

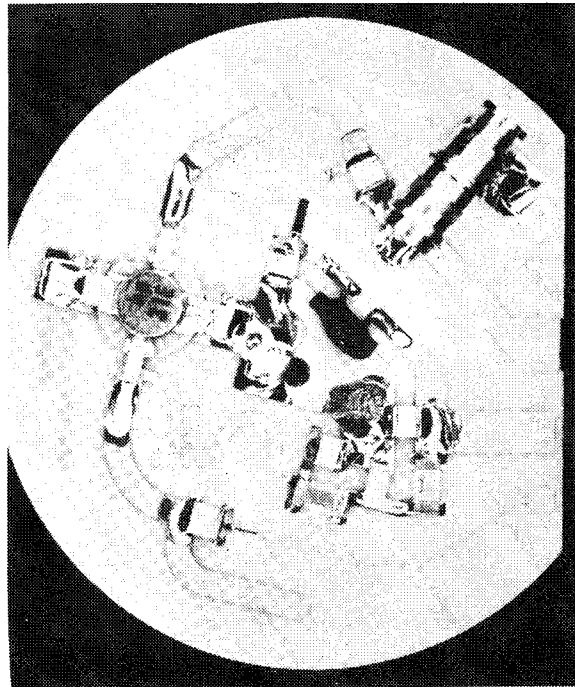

Figure 3 - A4 Board; 1.51 GHz Output Amplifier

Oscillator circuit turn-on stability, when loaded by the nonlinear times 2 multiplier, was improved by the addition of a buffer amplifier. RF output power variations with temperature were corrected by changing the power-amplifier stage DC biasing and adjusting the RF matching circuitry.

Metal web thickness between the stacked ceramic boards was increased, adding 1/4 inch to the overall package length. This eliminated the previous ceramic board fractures occurring during gunfire.

A stripline parallel coupled filter was designed with resonators 1/2 wavelength long and with coupling between adjacent 1/4 wavelength sections. The filter's required 2.47 inch length was folded in a horseshoe-shaped path to enable placement on the (A3) substrate's 1 1/4 inch diameter surface. A dielectric epoxy, Delta Bond 152, is used to bond the balanced stripline to the board.

Efforts to achieve a transmitter within the space limitations and with the desired electrical characteristics were unsuccessful. Combining the times 10 multiplier and 1.51 GHz stripline filter on the same alumina substrate (A3) caused severe electrical deviations related to resonant cavity response at the transmitter frequency.

An in-depth evaluation determined that project continuation was unwarranted. It was recommended that alternate approaches including voltage controlled oscillators, other substrate materials, and frequency multipliers be pursued.

BENEFITS

While no direct benefits can be attributed to this project because the L-Band transmitter was not successfully fabricated, the in-depth evaluation pointed the way to alternate approaches.

IMPLEMENTATION

Due to inability to achieve stated objectives, this project was not implemented.

MORE INFORMATION

Additional information may be obtained from Mr. Tom Liss, Harry Diamond Laboratories, Adelphi, Maryland, AUTOVON 290-3000 or Commercial (202) 394-3000. The work was contracted to Johns Hopkins University Applied Physics Laboratory under contract MIPR R-76-29.

Summary report was prepared by Stephen C. Yedinak, Manufacturing Technology Division, US Army Industrial Base Engineering Activity, Rock Island, IL 61299.

MANUFACTURING METHODS AND TECHNOLOGY
PROJECT SUMMARY REPORT
(RCS DRCMT-302)

Manufacturing Methods and Technology Project 374 3096 titled, "Manufacturing Processes for Laser Terminal Homing Seekers," was completed by the US Army Missile Command in June 1976 at a cost of \$450,000.

BACKGROUND

The laser seeker is a dome-shaped scanner used in active and semiactive guided missiles. It is composed of a spinning mirror/detector unit driven by electromagnetic coils and protected by a transparent dome, as shown in Figure 1. The seeker detects radiation from a laser-designated target and provides the missile with appropriate guidance signals.

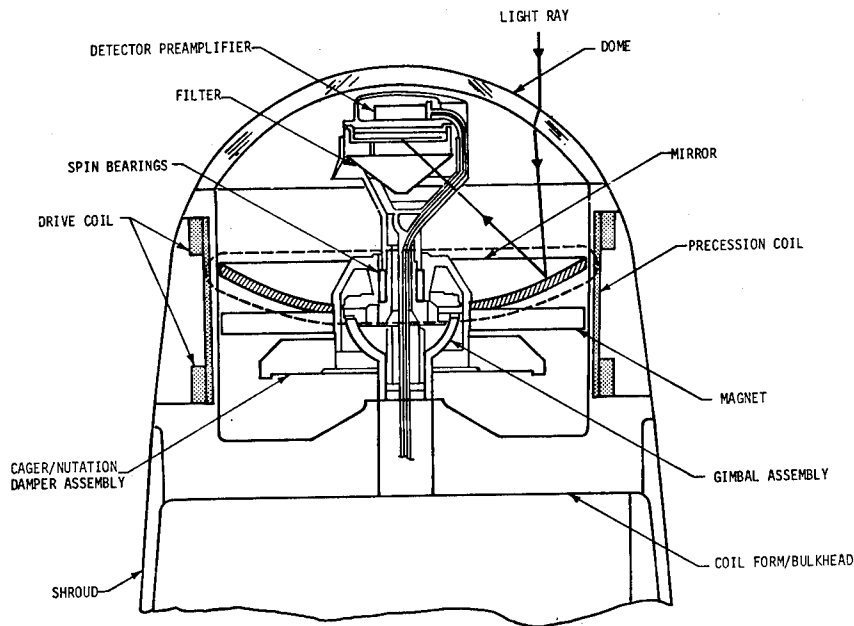

Figure 1 - Cutaway View of Laser Seeker

Laser seekers are used in quantity in Army systems such as HELLFIRE, MAVERICK, and CHAPARRAL and in the Navy BULLDOG missile. The seeker represents the most expensive subsystem on a homing missile, costing nearly as much as all other components combined. A significant cause of high production cost is the use of complex, multi-component construction. Efforts were needed to better integrate seeker subassemblies in order to achieve cost-effective production.

SUMMARY

Teledyne Brown Engineering of Huntsville, AL, completed the first half of a two-year contract to reduce the cost and weight of laser seekers that use the spinning mass assembly. Technology reviews were followed by prototype fabrication, evaluation, and final recommendation. Accomplishments in the eight problem areas addressed are summarized below:

1. Non-Metallic Support Structures - Effort was made to replace metal in the primary structure with plastic to reduce cost and improve producibility. A technology review concluded that injection molding of glass reinforced thermo-plastic was best for the electronics shroud and support structures.

2. Head Coil Integration - The seeker head contains several coils for motion detection and drive for the gimballed mirror/detector. The cancellation coils, along with caging and reference coils, were replaced with potentiometers resulting in overall parts reduction. Bifilar windings were used in the drive and precession coils to increase torque, balance, and efficiency.

3. Electronics Package - Discrete elements were retained for power supply circuitry while hybrid integration was adopted for preamplifiers, signal processors, and areas where specialty circuits had been established prior to this effort. The most efficient assembly method included both manual and machine insertion on planar circuit boards.

4. Molded Plastic Mirrors - A major cost reduction was found in using an injection-molded plastic mirror in place of the machine-ground glass or metal surface. Best results were achieved when a gold coating was vacuum-evaporated onto a mirror molded of high temperature Plexiglas-H acrylic.

5. Magnet Composition - Three types of magnetic alloys (cast, sintered, and plastic-bonded) and sintered ferrites were evaluated for use in the seeker spinning mass assembly. A casting of Alnico 5 was selected for its superior physical and magnetic strength.

6. Automatic Testing - A study of automatic test techniques showed that automation was cost-effective only in testing electronic packages. Test flow diagrams were developed and included fault isolation routines and repair flow diagrams. Optimum usefulness of automated testing will be realized with high production rates.

7. Gyro Balancing - Conventional balancing techniques now meet all military requirements and results suggested only minor improvements. Changes affected the dynamic balance testing and eliminated the costly step of laser balancing.

8. Powder Metallurgy - An assessment of powder metallurgy for producing metal parts for the seeker concluded that such molding processes are not presently cost-effective for the quantities involved.

The above achievements have resulted in significant cost reductions and fulfillment of all program goals. Integration of the design improvements and additional testing will be continued in follow-on Project 375 3096.

BENEFITS

The results of this first-year project are applicable to HELLFIRE, MAVERICK, CHAPARRAL, STINGER, and BULLDOG missile systems. Several changes have been made in various subassemblies, including a reduction of inductive coils from 16 to 7, adoption of a single injection-molded support structure, and improved drive circuitry. These improvements were combined with others to achieve an overall cost reduction of 50 percent for the production of laser seeker heads.

IMPLEMENTATION

The results of this highly successful project were implemented in a follow-on Project 375 3096, which is conducting prototype evaluations and demonstrations. Technical reports have been distributed to Government agencies and industry and project managers have been briefed on subsequent developments.

MORE INFORMATION

Further information may be obtained from Mr. Robert Austin, MICOM, AV 746-8445 or Commercial (205) 876-8445. The contract number is DAAH01-74-C-0836. The final report is number MSH75-AMC-1906.

Summary Report was prepared by Charles Miller, Manufacturing Technology Division, US Army Industrial Base Engineering Activity, Rock Island, IL 61299.

MANUFACTURING METHODS AND TECHNOLOGY
PROJECT SUMMARY REPORT
(RCS DRCMT-302)

Manufacturing Methods and Technology Projects 375 3073 and 376 3073 titled, "Manufacturing Techniques for Static Switches," were completed by the US Army Missile Command in June 1979 at costs of \$175,000 and \$125,000, respectively.

BACKGROUND

The intervalometer, an electromechanical stepping switch used for sequentially firing nineteen 2.75-inch rockets, exhibited faults common to such mechanical devices used in aircraft environments. Faults include short life and erratic operation due to mechanical part wear, misfires due to electrical contact degradation caused by moisture, corrosion and fungus, and irregular firing pulse times due to temperature sensitivity.

As an alternative, solid-state circuitry was known to provide accurate firing pulse timing regardless of environmental conditions, supply voltage fluctuations or unit age; and to assure self-protection against shorted or open squibs. A newly designed 10 KHz switch uses a scanning technique to locate the first unfired rocket by sensing squib resistance and fires it within the prescribed 30 milliseconds.

SUMMARY

The effort's objective was to establish manufacturing processes for an improved solid state sequencing switch used for the 2.75-inch rocket launcher. Work was performed by the FMC Corp, Ordnance Engineering Division at San Jose, CA.

The Phase I task verified that a solid state switch could be mass produced using common electronic production techniques. The following hardware simplifications were recommended for added reliability and cost savings, prior to actual production:

1. Improve printed circuit board (PCB) interconnect methods.
2. Substitute an output transformer more suitable for high volume assembly.
3. Convert discrete electronic components to hybrid circuits.
4. Reduce noise on the unfired lines.
5. Improve low temperature performance.

The Phase II task pursued the previous recommendations and demonstrated technology feasibility by fabricating four prototype devices. Included were:

1. A Kapton flexible printed circuit was developed to replace the two rigid printed circuit boards and all interconnecting wires used in the original switch.

2. Toroidal transformers were replaced by a type using ferrite cores and bobbins. The new ferrite transformer is smaller and can be machine wound for higher production rates.

3. Discrete electronic components were converted to a single hybrid circuit produced in prototype quantity and used successfully in the switch. The circuitry was redesigned using all CMOS logic instead of a mixture of CMOS and TTL. Since CMOS devices operate at higher impedance and lower power, this permitted smaller resistors and capacitors.

4. Noise caused by interaction between adjacent output lines was reduced by redesigning the circuit to use every other output line and grounding unused lines.

5. Device output was guaranteed at low temperature (-55°C) by use of Texas Instruments Darlington transistor driver ULN2004AN.

The switch support was machined from cast aluminum and chemically coated for corrosion resistance. The shell was formed with molded fiberglass. After flexible circuit and component assembly the completed unit was potted with RTV. Functional testing was performed both before and after potting.

Hybrid circuit fabrication processes include: Substrate ink printing, resistor trimming, epoxy screening for component attachment, and chip and wire bonding with both aluminum and gold wire. The substrate was epoxy mounted in a metal flatpack. The hybrid circuit is shown in Figure 1 and the complete switch in Figure 2.

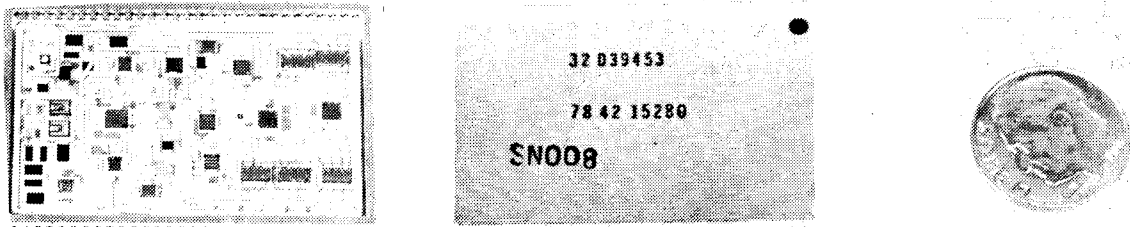

Figure 1 - Hybrid Circuit

Four prototype switches were delivered to the Missile Command. Documentation for an assembly line capable of producing 10,000 switches per 35-hour week was prepared. Personnel, tooling, fixtures and test equipment required for assembly were determined. An average cost of \$284 per switch (including a \$180 hybrid circuit) was calculated based on a 10,000 unit production run at the rate stated above.

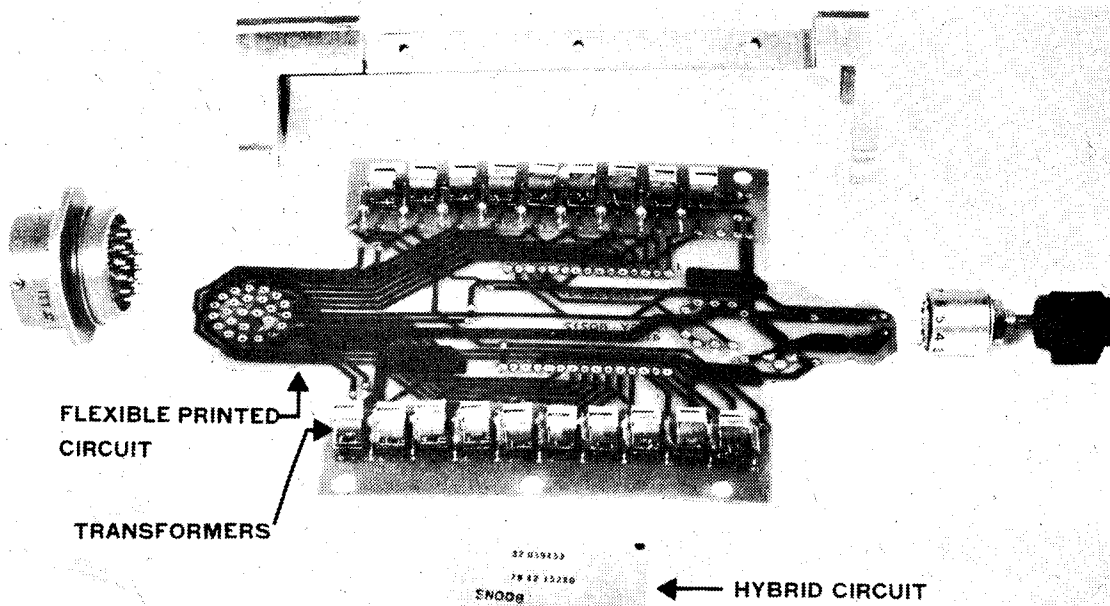

Figure 2 - Major Components of Static Switch

BENEFITS

This project resulted in an improved solid-state sequencing switch with greater reliability, accuracy, and longer life.

Assembly and test methods were identified which provide opportunity for cost reduction and higher production rates.

IMPLEMENTATION

The results of this effort are available for implementation. Copies of the documentation have been furnished the 2.75-inch Rocket FFAR System Project Manager, and the Navy at Patuxent River. The Navy was also given one prototype switch for shipboard electromagnetic interference evaluation. Results are not yet available.

MORE INFORMATION

Additional information may be obtained from Mr. Dean C. Andrus, FMC Corporation, Ordnance Engineering Division, San Jose, CA, Commercial (408) 289-3342. The contracts were DAAHQ1-75-C-0552 and DAAK40-76-C-0155.

Summary Report was prepared by Stephen C. Yedinak, Manufacturing Technology Division, US Army Industrial Base Engineering Activity, Rock Island, IL 61299.

MANUFACTURING METHODS AND TECHNOLOGY
PROJECT SUMMARY REPORT
(RCS DRCMT-302)

Manufacturing Methods and Technology Project 377 3217 titled, "Manufacturing Methods for Traveling Wave Tubes," was completed by the US Army Missile Command in December 1979 at a cost of \$498,000.

BACKGROUND

The traveling wave tube (TWT) is a complex microwave device used for modulating and amplifying high frequency signals employed in guidance and tracking radars in PATRIOT and other missile systems. This small, lightweight device, Figure 1, contains over 700 parts made from 24 materials and represents the system cost driver. Work was needed to make tube construction and testing less labor intensive and more efficient. Of special concern was the configuration of the TWT electron gun, subject to tight military specifications. Earlier projects conducted by ERADCOM focused on improved heat tolerance, life expectancy, and cooling apparatus, but did not directly address production improvement.

SUMMARY

Litton won a multi-phase contract to develop low cost production methods for missile-borne traveling wave tubes. The award included a six-month basic contract to build a test unit and an Option I program to select materials and methods suitable for a pilot line planned in a follow-on option. The first option also called for the delivery of two TWT's meeting all PATRIOT specifications.

Results from the initial six-month effort provided an acceptable TWT having an electron gun with excellent (99%) beam transmission. The first option concentrated on reducing cathode warm-up time by testing heater configurations, dielectric coatings, and potting techniques. In all cathodes, the emitter included a tungsten-iridium matrix which provided high current capability and an operating temperature 100°C less than that of pure tungsten.

Early cathode/heater designs used a photo-etched flat pancake heater sandwiched between the cathode and a similar shaped molybdenum cup. The cup and cathode were flame-sprayed with alumina for electrical isolation and assembled for warm-up cycling tests. All units failed during test due to the heater's failure to conform to the curved cathode. Another heater design used a cataphoretically-coated tungsten-rhenium wire held between a cathode and cup; frequent failures were attributed to coating deterioration which led to turn-to-turn heater shorting. Use of an aluminum nitride coating was discontinued when it was found to dissociate at test temperatures.

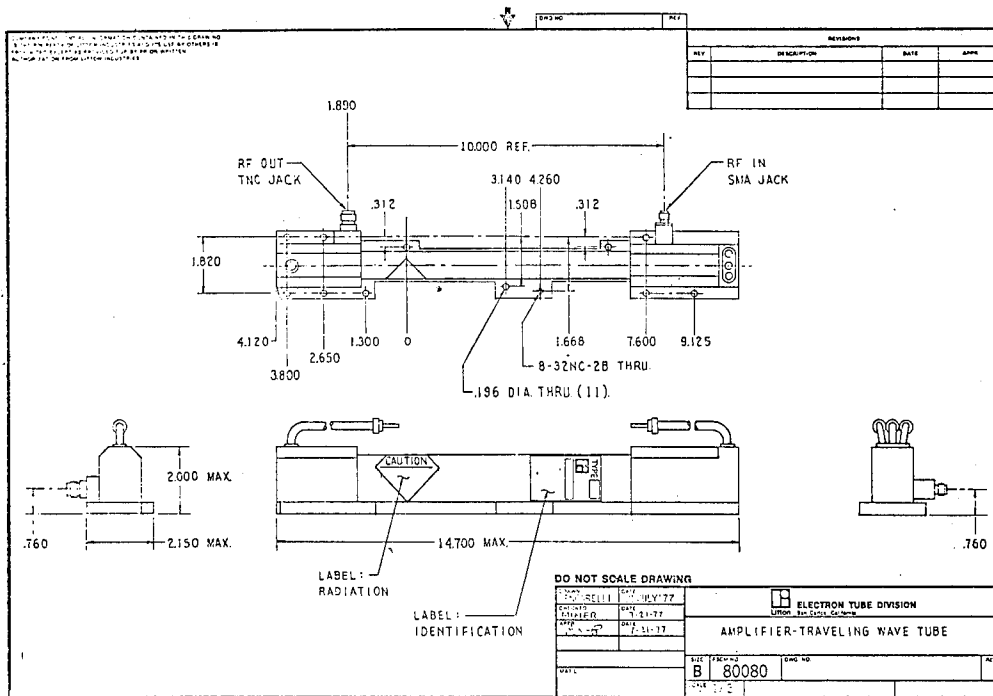

Figure 1 - Outline Drawing of Proposed TWT

After additional work on the cathode support structure, a satisfactory fast warm-up cathode was made. The final design integrated a tungsten/iridium cathode button with a support sleeve, permitting alumina potting to be poured directly into the sleeve, Figure 2. This configuration also allowed closer heater-to-cathode positioning for more efficient electron production. A fixture was made to position the heater wire during the potting operation.

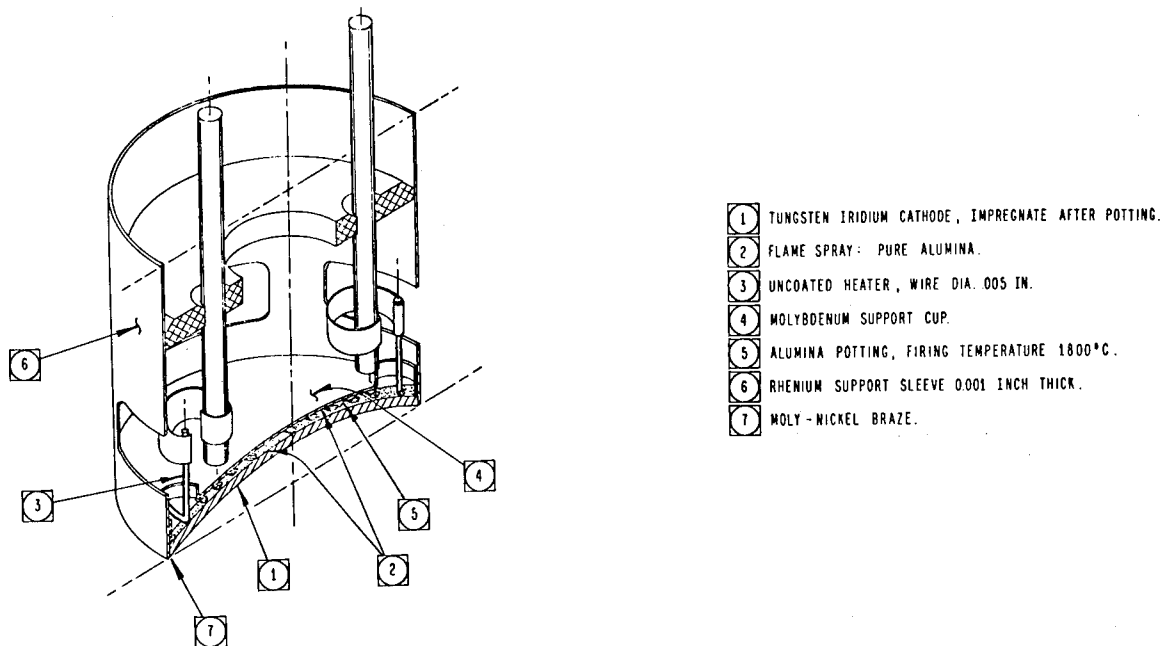

Figure 2 - Cathode - Heater Assembly
(Hard Potting Design)

Shock, vibration, and cycling tests were performed on assembled TWT's by Litton and Raytheon with good results. The units passed all tests, including the critical 3.4 second limit for cathode warm-up. With the delivery of the two tubes, this project provided all required data for the projected second option.

BENEFITS

Litton refined the construction of the traveling wave tube while achieving a very efficient, fast warm-up electron gun. Manufacturing processes were chosen and guidelines (floor layout, flow charts) developed for a follow-up MMT project. While this work was directed toward the PATRIOT system, processes for fast warm-up cathodes can be applied in other programs.

IMPLEMENTATION

The results of this successful project will be used in the next phase of the Litton contract, in which a scaled-down pilot line will be designed and fabricated. A technical report has been distributed to government agencies and industry.

MORE INFORMATION

Further information may be obtained from Mr. Virgil Irelan, MICOM, AV 746-4473 or Commercial (205) 876-4473. The contract number was DAAK40-77-C-0229.

Summary Report was prepared by Charles Miller, Manufacturing Technology Division, US Army Industrial Base Engineering Activity, Rock Island, IL 61299.

MANUFACTURING METHODS AND TECHNOLOGY
PROJECT SUMMARY REPORT
(RCS DRCMT-302)

Manufacturing Methods and Technology Project 378 3140 titled, "Improved Manufacturing Processes for Silicon Vidicons," was completed in January 1980 by the US Army Missile Command at a cost of \$149,000.

BACKGROUND

Television cameras are used extensively by the three Services in remote missile targeting, night vision devices, and in HELLFIRE, MAVERICK, AQUILA, and other missile systems. Because of their ruggedness and compact design, silicon target vidicons are preferred over other types for detection of near infrared radiation. Unfortunately, their attractiveness is reduced by their high unit cost (\$5000) and the low yield (10%) which result from labor intensive, hand assembly methods. These problems were addressed in Projects 376 3140 and 37T 3140, which initiated work on production methods for silicon vidicons. After defining critical processes, two sample lots were made with yields three times better than those conventionally produced. Problems encountered in the initial runs were addressed in the present project.

SUMMARY

The objective of this project was to develop a production plan for rugged, high-quality silicon vidicons, with emphasis on the critically precise silicon disk. The contract was awarded to RCA Corporation and required a final run of 40 tubes within a four-month period.

The vidicon tube is constructed of a three-inch long, one-inch diameter envelope of metal and alumina ceramic, Figure 1. Mounted at one end is the silicon target bonded to a glass faceplate. The other end contains the electron gun yoke, a vacuum exhaust tube and several electrodes. To complete the vidicon assembly, the tube fits into a cylindrical sleeve containing deflection and focusing coils.

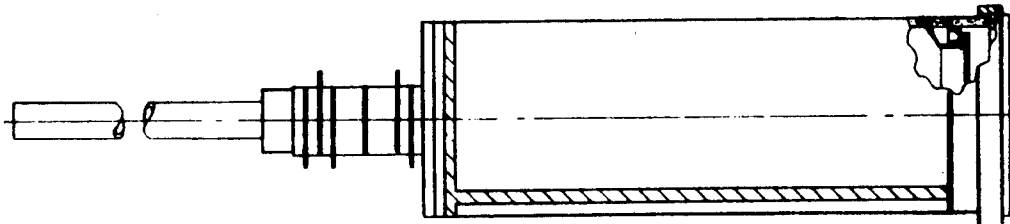

Figure 1 - Silicon Vidicon Camera Tube

The silicon target consists of a matrix of 627,000 p-n diodes grown on a 15 micron-thick wafer of single crystal silicon. The n surface faces outward while the p-regions are exposed to the scanning vidicon beam. P-type islands are spaced 14 microns apart and include individual "landing pads" to collect electrons from the scanning beam. This structure is produced in the following steps:

1. After the silicon is cleaned and polished, a one-micron layer of silicon dioxide (SiO_2) is deposited and three-micron diameter diode sites are etched away using non-contact photolithography, Figure 2a.

2. Boron-doped polysilicon is grown at a high temperature (900°C) to form a 0.6 micron layer over the surface. The polysilicon layer is then oxidized to a thickness of 0.4 micron, Figure 2b.

3. Negative photoresist is exposed by contact printing to leave square oxide areas centered over the original hole sites, Figure 2c.

4. Using a hydrofluoric and nitric acid, the silicon layer is etched down to the lower oxide, leaving the square landing pads. At this time, boron is diffused into the base silicon to form the diodes, Figure 2d. A final acid etch removes the oxide from the pads.

Production runs of silicon targets were successfully achieved with yields as high as 80%, while the actual tube yield improved from 32% during initial work to 52% at the final production phase.

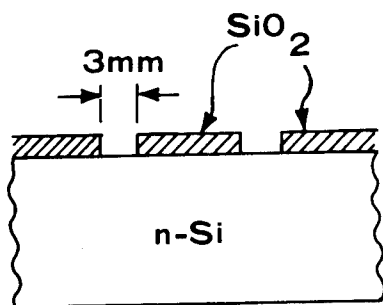

Figure 2a

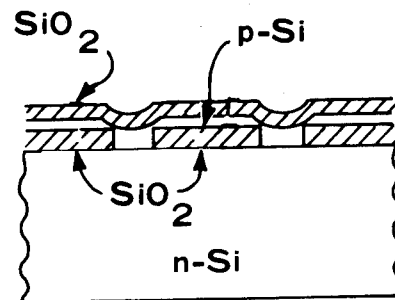

Figure 2b

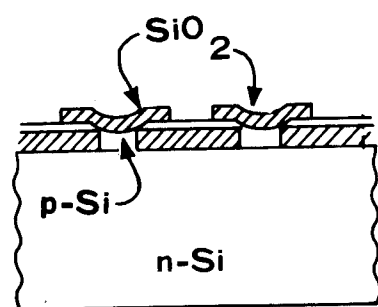

Figure 2c

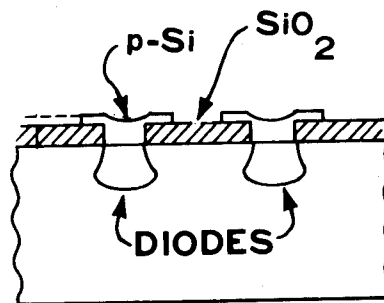

Figure 2d

Figure 2 - Schematic of the Principal Steps in the Manufacture of Silicon Targets

BENEFITS

A major goal of this project was to reduce the silicon vidicon's susceptibility to "blooming" which is a temporary loss of visual information caused by excessive incoming light. This was successfully met by the "landing pad" design which also enhanced image resolution and reduced the level of dark (leakage) current.

The contractor has indicated a price reduction from \$5,000 to \$625 when produced in quantities of 2,500.

IMPLEMENTATION

This project was not implemented in the Target Acquisition and Designation System or the Advanced Attack Helicopter because the company that planned to use this newly developed method (Northrop) lost in competition to another contractor. However, the RCA vidicon is being considered by the Army Helicopter Improvement Program (HIP) for use in Scout helicopters. The HIP program is in the procurement phase and two competitors have chosen the RCA design. Thus, the MMT work will most likely be implemented.

Reports detailing this technically successful effort have been distributed to government agencies and industry.

MORE INFORMATION

Further information may be obtained from Mr. E. D. Crosswhite, MICOM, AV 746-2922 or Commercial (205) 876-2922. The contract number is DAAH01-78-C-0996.

Summary Report was prepared by Charles Miller, Manufacturing Technology Division, US Army Industrial Base Engineering Activity, Rock Island, IL 61299.

MANUFACTURING METHODS AND TECHNOLOGY
PROJECT SUMMARY REPORT
(RCS DRCMT-302)

Manufacturing Methods and Technology Project 577 3905 titled, "PS127 Reserve Power Supply Manufacturing for the M587/724 Fuze" was completed by the US Army Armament Command in February 1981 at a cost of \$375,000.

BACKGROUND

The PS127 liquid reserve power supply for the M724/587 electronic time fuze has a number of design features that were only addressed in R&D type fabrication and assembly in the past. Perpetuation of the manual techniques employed in the R&D program would preclude efficient, low-cost manufacture of the large quantity of power supplies planned for production.

SUMMARY

The objective of this project was to develop and demonstrate processes and pilot facilities to aid producibility of the PS127 power supply at minimum cost. It was accomplished under two successive contracts.

A special machine was fabricated to automatically fill the copper ampule with fluoboric acid and weld a copper lid onto the ampule using tungsten-inert gas welding. Satisfactory filling to tolerance was accomplished. The power supply for the welding was overpowered and required severe cut-back of power setting to produce an adequate weld. Although the reject rate was excessive, a low production rate was possible. A welder more precisely designed for the production task will be required.

Progressive dies were designed and fabricated to punch electrode plates and corresponding paper separators, both in matrix form. Several thousand matrices were successfully punched. Also, stacking fixtures were designed and fabricated to allow matrices to be stacked in the required sequence and the entire stack then heat bonded. These fixtures were successfully demonstrated.

A break-away device was designed and fabricated to separate the individual plate stacks from the matrix support strips. Twenty matrices were successfully separated. Finally, a varnish coating machine was designed and fabricated to coat the inner edge of each lead dioxide electrode. This was accomplished in the matrix form with successful coating of all electrodes in 25 matrices demonstrated prior to machine acceptance. A blow-up of the final PS127 Power Supply is shown in Figure 1.

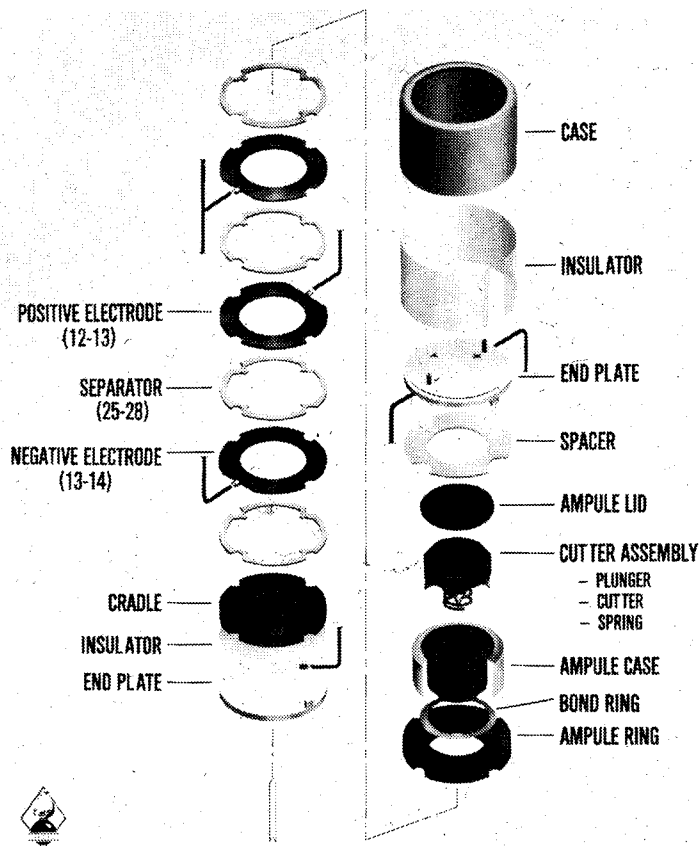

Figure 1 - PS127 Power Supply

One hundred and sixty PS127 batteries were built using the parts resulting from the new devices. Final assembly was carried out by hand and the batteries were successfully tested, thereby validating both the processes and the machines.

Data generated in the process of using the above devices formed the basis for recommendations of modifications to be employed in an Initial Provision of Facilities (IPF) design.

BENEFITS

The primary benefit from this MM&T effort is the advance in the art of fabricating and coating electrodes in a mechanized manner. In addition, problems associated with mass production of electrolyte bearing ampules were assessed and resolved prior to the building of a full IPF. Actual production machines (rather than prototypes) were designed and built. A fixed price production contract for the PS127 reserve power supply production has been awarded at roughly one-half of the prior hand assembly price. This could not have occurred in the absence of the MMT program results.

Although the effort was carried out specifically for the M587 and M724 fuzes, the resulting facility and the technology evolved will be applicable to reserve batteries for other fuzes.

No patent rights are involved in this program and full disclosure of manufacturing methods has been made to the Government.

IMPLEMENTATION

All machines, tooling, designs, hardware and methodology stemming from the MMT project have been transferred formally to the IPF contract at Joplin, MO. The physical facilities are very similar and roughly half the size of the IPF machines. They will be used as backup for the production line. Although the production buys for the PS127 reserve power supply have been cut back substantially from earlier plans, at least 250,000 units will be made. It is clear that the MMT project played a major role in allowing production schedules and target costs to be met for this production.

MORE INFORMATION

More information concerning this project may be obtained from Mr. Fred G. Turrill at AV 290-3114 or Commercial (201) 394-3114. Reference data item A009 of Contract DAAK39-78-C-0108, with HDL dated 31 August 1980.

Summary Report was prepared by Wayne Hierseman, Manufacturing Technology Division, US Army Industrial Base Engineering Activity, Rock Island, IL 61299.

MANUFACTURING METHODS AND TECHNOLOGY

PROJECT SUMMARY REPORT

(RCS DRCMT-302)

Manufacturing Methods and Technology Project 672 7191 titled, "Long Wavelength Optical Fabrication Techniques for Far Infrared," was completed by the US Army Armament Materiel Readiness Command in June 1974 at a cost of \$250,000.

BACKGROUND

While early military applications of infrared technology were based on the quasi-visible (near) wavelengths between 0.9 and 1.3 microns, subsequent efforts have concentrated on longer (far) wavelengths. The far infrared window is attractive to military designers because of the difficulty in disguising target signatures, increased practicality of passive detectors, and availability of convenient laser wavelengths.

The development of far infrared detectors has been impeded by primitive production methods for refractive IR elements such as domes and lenses. The use of germanium offers superior optical and mechanical properties, but introduces formidable production problems. Difficulty is also met in optical testing and measurement of lenses, since germanium is opaque to visible light and standard techniques cannot be used. Other deficiencies in the shaping and polishing of the lens blanks result in slow, costly production and require re-evaluation and improvement.

SUMMARY

This project was the first year of a two-year effort conducted at the former Frankford Arsenal to develop procedures for efficient fabrication of far infrared lenses. Major emphasis was placed on development of lens testing routines, on refining of graining and polishing techniques, and on complete documentation of all production steps. An initial study of the physical properties of germanium was made so that infrared designs could be projected from similar data for established visible-region optics.

New testing procedures studied include those for characterizing preproduction germanium ingots; the tests employed non-visible radiation such as x-rays and coherent infrared light. Parameters such as focal length, resolution, index of refraction, and homogeneity were among the required measurements. X-ray methods offered simple routines and high resolution, but may not be appropriate, since x-rays do not propagate through the lens the same way infrared radiation does. Infrared laser interferometry provided a direct measure of lens variation suitable for a final quality test but could not distinguish the cause of the variation. A suggested test procedure would include several tests because a single procedure cannot satisfy all requirements.

In addition to evaluating test procedures, the project refined lens production methods with emphasis on the following areas:

1. Rough cutting of germanium stock into square blocks: Effort was made to minimize generation of germanium dust which cannot be reclaimed.

2. Coring of lens blanks: Suggested methods of cutting lens blanks included use of a modified curve generating machine and a drill press. The curve generator offered superior cooling of the workpiece and faster cutting time.

3. Mounting blanks for grinding and polishing: A multiple-cavity spot block fixture was considered superior because of the much shorter time required to load it. In addition, plasters and waxes were found to be suitable, economical adhesives for bonding lens blanks onto the fixture.

The above production steps were included in a comprehensive shop manual for advancing the art in far infrared manufacturing methods.

BENEFITS

This project focused on improving manufacturing methods for optical germanium elements for far infrared detector systems. It provided detailed documentation for improving production procedures at optics firms. Results included information regarding material specifications, processing guidelines, and quality assurance testing.

IMPLEMENTATION

The results of this successful project were used in follow-on project 673 7191 which expanded production improvements made during this project. A final report was published and distributed to Government agencies and industry.

MORE INFORMATION

Additional information may be obtained from the project officer, Mr. Joseph Jacobson, Navy Air Development Center, AV 441-2440 or Commercial (215) 672-2440. The contract number was DAAA-25-73-A0120. The report number was R-3020.

Summary Report was prepared by Charles Miller, Manufacturing Technology Division, US Army Industrial Base Engineering Activity, Rock Island, IL 61299.

MANUFACTURING METHODS AND TECHNOLOGY
PROJECT SUMMARY REPORT
(RCS DRCMT-302)

Manufacturing Methods and Technology Project E78 3532 titled, "Molten Salt Lithium/Chlorine Battery," was completed by the US Army Mobility Equipment Research and Development Command in July 1980 at a cost of \$120,000.

BACKGROUND

Earlier MMT projects in this area advanced the state of the art for a molten salt Li/Cl battery. However, problems remained in the hot seal, separator material, and current leakage that had to be solved before the new batteries could be used in fork lift trucks as desired. A review of these prior efforts suggested that future work be concentrated on a cell with an iron sulfide cathode. This would reduce current leakage as well as increase capacity. The anode would remain a lithium-aluminum alloy and the electrolyte, a mixture of lithium chloride and potassium chloride.

SUMMARY

The objective of this program was to make improvements in the manufacturing process of molten salt batteries and demonstrate these in an operational fork lift. For this application, minimum battery volume is more important than weight, which serves as a counterbalance. Increased capacity is necessary to reduce the number of batteries, such as lead-acid batteries, required for shift operations and during war emergencies. A contract was let to develop and test a 4 KWHr Lithium Aluminum/Iron Sulfide battery. The proposed and achieved results are shown in Table 1.

Table 1 - 4 KWHr LiAl/FeS Battery Performance
(2 Series of 5 Cells in Parallel)

	PROPOSED	ACHIEVED (CYCLE #4)
1. ENERGY STORAGE-KWHR PER 6 HR DISCHARGE (C/6)	4.0	3.984
2. VOLTAGE PROFILE - VOLTS CHARGE/OPERATING/DISCHARGE	8.25/6.0/5.0	7.86/6.0/5.34
3. WEIGHT - KG	75-80	77.11
4. VOLUME - LITERS	65-70 MAX.	55.34
5. HEAT LOSS (ON STANDBY)-WATTS	500 MAX.	<250
6. DIMENSIONS - LENGTH x WIDTH x HEIGHT - INCHES	20 x 15 1/4 x 15	20.57 x 11.60 x 14.15
7. SPECIFIC ENERGY-WH/KG (C/6) CYCLE #4 CYCLE #50 CYCLE #100	90-55 450	51.67 30
8. ENERGY DENSITY - WH/LITER (C/6)	55-60 MIN.	72
9. PEAK POWER - 3 SEC PULSE - KW 5% DISCHARGE 50% DISCHARGE 75% DISCHARGE	2-3	2.62 2.02 1.87

As indicated, for rating purposes, all design goals were satisfactorily completed except for cycle life and peak power. Also, progress on the hot seal problem has been made. One cell was held at 450°C for three months and cycled for 60+ cycles with minimal loss in capacity.

Individual cell lives were increased substantially. Although reliability has still not been proven, some cells have been successfully cycled for over 800 cycles.

Two new problems were discovered in constructing the module. They were the corrosion of the copper connectors and the potential of rupture. It appears that the corrosion can be resolved by nickel plating. Testing revealed that the salt inside the cells expands on heatup when combined into a module. This was not a problem with individual cells. In a battery, cells will be made larger to avoid a rupture problem.

The boron nitride felt separator, which is the main cost item, has been reduced from \$500/ft² to \$190/ft². This must be reduced further and it is believed this will be accomplished.

BENEFITS

An economic analysis has shown that substantial cost savings could result from substituting these batteries for lead/acid fork lift batteries.

Energy density of the batteries developed are about two times that of the conventional lead-acid battery.

These batteries can be used in all electric vehicles, for uninterruptible power sources, and fork lift trucks. This will save oil, reduce pollution and increase operating time and performance. Since the batteries are sealed, they are also reportedly safer than lead-acid batteries which release minute quantities of the poisonous gases arsine and stibine.

Patent rights are all owned by the Government.

IMPLEMENTATION

Work is continuing on this effort in a follow-on project. Batteries are being fabricated and they will be tested and evaluated by the MERADCOM Materials Handling Equipment group.

MORE INFORMATION

Additional information on this project can be obtained from Mr. Edward J. Dowgiallo, AV 354-5752 or Commercial (703) 664-5752.

Summary Report was prepared by Wayne Hierseman, Manufacturing Technology Division, US Army Industrial Base Engineering Activity, Rock Island, IL 61299.

MANUFACTURING METHODS AND TECHNOLOGY
PROJECT SUMMARY REPORT
(RCS DRCMT-302)

Manufacturing Methods and Technology Project H73 9605 titled, "Thin Film Ratiometer," was completed by the US Army Electronics Research and Development Command in January 1976 at a cost of \$161,663.

BACKGROUND

A ratiometer is an electrical device similar to a rotary potentiometer, but has a fixed resistor in addition to the variable element. It is used as an adjustable time-setting device in an electronic fuze, providing a resistance ratio of the variable and fixed resistances for the timing circuitry. The flat, annular device is mounted within a cavity in the detonator block assembly.

Conventional ratiometers employ thick-film resistors which have an accuracy of $\pm 3\%$. By adopting a thin film resistor design, the timing accuracy may be upgraded to $\pm 1\%$, improving targeting effectiveness. The thin film material is considered superior to conductive plastics or cermet (ceramic-metal) since it is less sensitive to temperature variation and generates less electrical noise. Also, the thin film process is a well established technique, and studies at Harry Diamond Labs have demonstrated thin film suitability in precision ratiometers.

SUMMARY

The objective of the project was to establish a pilot production source and to increase the yield of vapor-deposited thin film ratiometers. The contract was awarded to TRW Eastern Research Laboratories in Philadelphia with the cooperation of Western Electric Company.

The thin film ratiometer is composed of an annular ceramic substrate onto which conductive paths are deposited by vaporization, and resistive material applied by sputtering. The thickness of these deposits is on the order of one micron. High purity alumina was selected for the substrate material, while chromium was chosen as the conductor. Tantalum nitride was used for the resistor paths because of its linear electrical properties; the conductance of the path is proportional to the amount of tantalum nitride deposited. 1.5 mil wide electrical paths were etched on the alumina disks in concentric patterns using photolithography techniques.

During fabrication, six substrates were formed together as a "snap-strait" and processed simultaneously for greater economy, Figure 1. After being cleaned, the substrates were fed into a continuous sputtering machine for deposition of one to two microns of tantalum nitride. The sputtering machine incorporated mechanically pumped, double sealed ball locks to permit the introduction and

removal of substrates without affecting the sputtering vacuum. A vacuum evaporation chamber was then used to deposit a thinner coating of chromium onto the wafer. Photolithographic etching operations were performed to first remove unwanted chromium and then excess tantalum nitride from the substrates, Figure 2. These steps involved photosensitizing the substrate, pattern exposure, photoresist development and acid etching. An anodization process was applied to the tantalum nitride patterns to achieve precise resistance values in a finely-controlled manner. The substrate was then laser scribed, mechanically separated into individual elements, and lightly machined to remove all excess ceramic. Electrical testing was conducted after the elements were bonded onto the detonator block with tape adhesive.

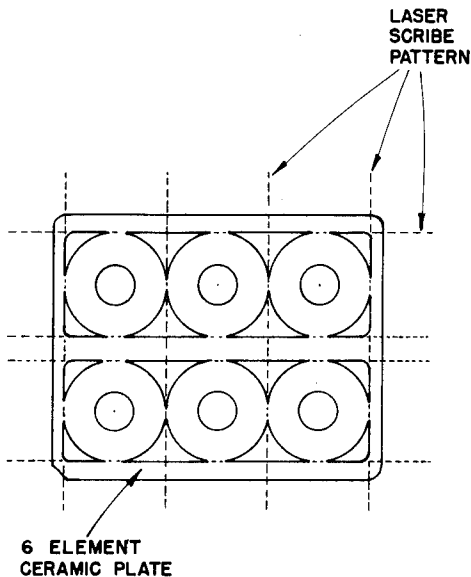

Figure 1 - Ceramic Laser Scribe Pattern

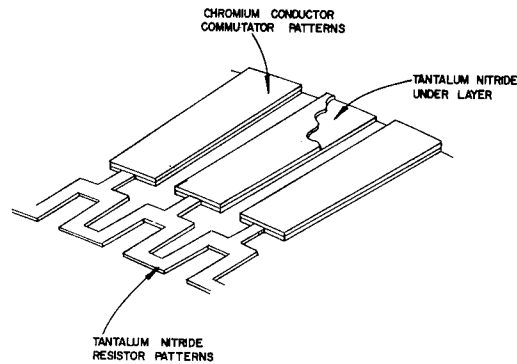

Figure 2 - Section Sketch of Commutator & Resistor Patterns

Low yields experienced during production of engineering samples were caused mainly by unsatisfactory physical characteristics of the substrates. After consultation with the vendor, modifications were made which provided satisfactory yields and a pilot production of 5000 units was completed.

BENEFITS

This project developed an effective manufacturing method for the production of thin film ratiometers to be used in electronic fuzes. Adoption of the thin film unit will provide superior timing accuracy; continued work with thin film technology is being conducted by Honeywell under contract with ERADCOM.

IMPLEMENTATION

This effort to establish a production method for fabricating thin film ratiometers was technically successful. However, the contractor fabricating the fuze circuitry elected to use a thick film ratiometer and thus the project results have not yet been implemented.

MORE INFORMATION

Additional information on thin film work may be obtained from Mr. Isaac Pratt, ERADCOM, AV 995-2308 or Commercial (201) 544-2308. A final Technical Report is available from DTIC; the contract number is DAAB05-73-C-2077.

Summary Report was prepared by Charles Miller, Manufacturing Technology Division, US Army Industrial Base Engineering Activity, Rock Island, IL 61299.

MANUFACTURING METHODS AND TECHNOLOGY
PROJECT SUMMARY REPORT
(RCS DRCMT-302)

Manufacturing Methods and Technology Project R77 3112 titled, "MM&T - Manufacturing Multilayer Rigid-Flex Harness", was completed by the US Army Missile Command in June 1980 at a cost of \$350,000.

BACKGROUND

The COPPERHEAD missile, a cannon-launched artillery shell with terminal infrared guidance, failed when it was test fired during the development phase.

Failure analysis on defective systems indicated that breakdown was caused by tears and breaks in the "motherboard" of the guidance electronic assembly. This board contained critical electronic devices and supported flexible sections which made guidance system interconnections with all other boards.

An intensive investigation revealed no single obvious cause for the failures. This MMT project was funded to improve motherboard reliability by selecting optimum materials and improving manufacturing procedures.

SUMMARY

The contract was awarded to the McDonnell Douglas Electronics Company. Work was divided into two phases.

Phase I evaluated existing industry fabrication methods for rigid-flex multilayer boards and identified problem areas. Typical industry problems associated with rigid-flex boards (RFBs) were misregistration, drill smear, delamination, material/process incompatibility, and plating defects.

Rigid-flex boards made of five candidate material systems were fabricated and evaluated for process ease (lamination, drilling, smear removal, plating), thermal shock resistance, and registration integrity.

Tests indicated the optimum material combination is rigid: copper-clad epoxy-glass laminate; flexible: copper-clad polyimide laminate, polyimide coverlay, and acrylic adhesive; B-Stage: epoxy-glass.

This material system exhibited best processing ease, registration integrity, plated through-hole quality, and thermal shock resistance. Boards could be routinely fused in hot oil and test tabs subjected to immersion in 500°F molten solder without delamination. Analysis of material cost and availability revealed the system was an attractive alternative to the others.

The basic fabrication process selected is outlined in Figure 1. Flexible innerlayers were processed with full coverlay lamination. Rigid external layers were processed in a conventional manner. Both rigid and flex layers were laminated at 200-250 psi and 340°F for slightly over one hour. Normal drilling was followed by plasma etching and plating.

FLEX LAYERS



RIGID LAYERS

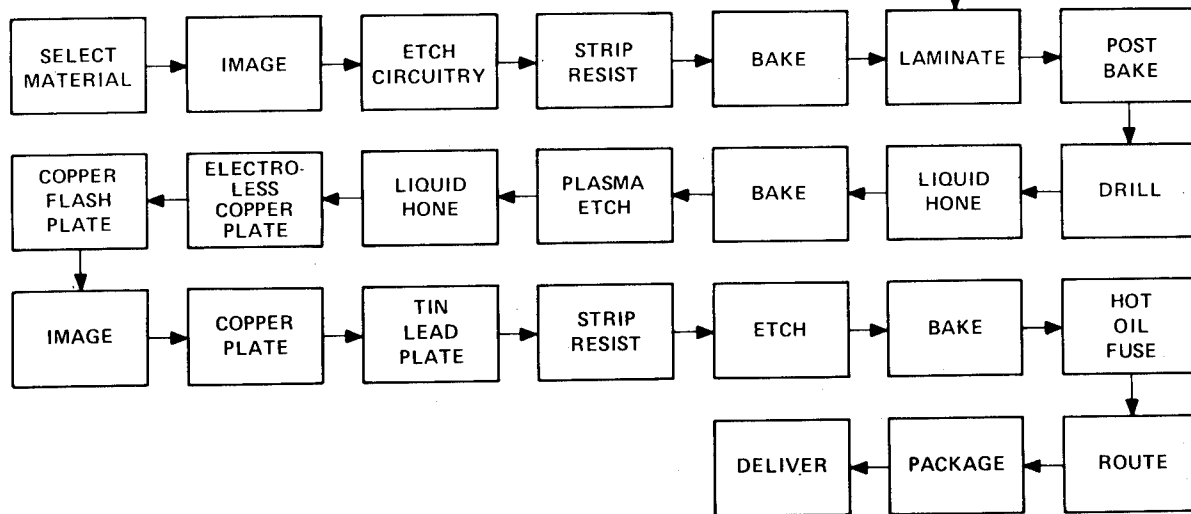

Figure 1 - Rigid-Flex Flow Cycle

The Phase II effort optimized selected processes in the fabrication cycle. Improvements were incorporated for coverlay treatments, tooling and layout methods, lamination, drilling, plasma etching, cleaning, and plating methods.

Requirements for a production line, capable of producing 750 units per day and a pilot line were documented. A pilot line was assembled and 100 RFBs were fabricated and tested to the requirements of MIL-P-50884 and IPC-ML-950.

The RFB selected, a motherboard used on the COPPERHEAD program, is shown in Figure 2. It is a six-layer RFB with eleven individual rigid areas interconnected by flexible wiring.

Tests included flexural strength, peel strengths (flexible), insulation resistance, plating adhesion, flammability and water absorption. In addition, numerous in-process tests were performed over several months at critical steps in the cycle to verify the integrity of the drilling, plating and lamination.

Excellent results were obtained verifying both the processing ease and ruggedness of the RFBs.

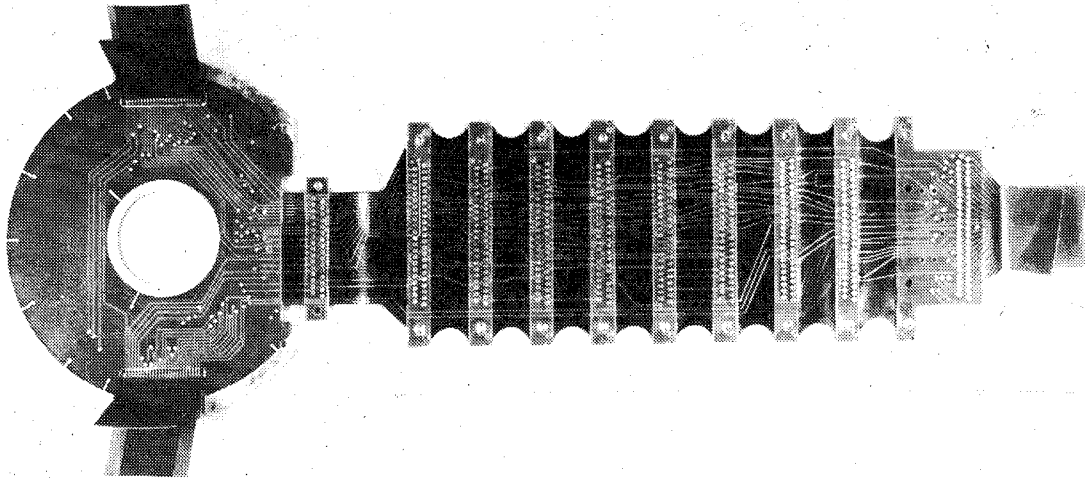

Figure 2 - Rigid Flex Multilayer Board

BENEFITS

As a result of this project, a material savings of \$43.00 per board and a 25 percent yield improvement was attained. A cost/value analysis of the develop process, based on a 10,000 motherboard production quantity, projected cost savings of approximately \$2.94 million.

IMPLEMENTATION

Firing tests were made with the new rigid-flex assembly. Three successive missiles, each equipped with the same rigid-flex assembly, were test fired and soft landed without damage or failure. This constituted the first three successful COPPERHEAD firings.

The initial successes were sustained in added tests so that the end product materials and manufacturing process was adopted for COPPERHEAD even before the MMT project was formally concluded.

MORE INFORMATION

Additional information may be obtained from Mr. Robert Brown, US Army Missile Command, Redstone Arsenal, AL, AV 746-5742 or Commercial (205) 876-5742. The contract was DAAK40-78-C-0244.

Summary Report was prepared by Stephen C. Yedinak, Manufacturing Technology Division, US Army Industrial Base Engineering Activity, Rock Island, IL 61299.

MANUFACTURING METHODS AND TECHNOLOGY
PROJECT SUMMARY REPORT
(RCS DRCMT-302)

Manufacturing Methods and Technology Project R77 3133 titled, "Production of Lithium Ferrite Phase Shifters for Phased Array Radars," was completed by the US Army Missile Command in June 1979 at a cost of \$215,000.

BACKGROUND

While the phased array radar antenna is a well-established device for multi-target tracking, phase shifting elements used in the scanner have undergone a steady evolution for over 20 years. Phase shifter design changes are largely motivated by the need to improve performance and reduce unit cost. Since a phased array radar employs thousands of phase shifters, efficient production of these elements is vital.

Typical shifter elements have been composed of a dielectric material surrounded by a toroid of rare earth garnet. Extensive R&D was conducted to replace this costly materiel with a lithium ferrite compound, while an improved dielectric-toroid bond was sought. One attempt to solve both problems employed the arc plasma spraying technique to deposit ferrite directly onto the dielectric, but yields were low and quality unsatisfactory.

Persistent difficulty in making ferrite shifters occurs in forming a uniform toroid while achieving suitable magnetic properties. These problems may be overcome by the adoption of a newly-developed ferrite shifter configuration which affords greater design flexibility while reducing production complexity.

SUMMARY

The objective of this project was to establish a production method for reducing the high cost of phase shifters for use in phased array radar antennas. Shortly after the contract was awarded to Raytheon, it was decided that work should focus on a newly developed shifter of simpler construction.

The conventional shifter cross section is shown in Figure 1 while the new design is shown in Figure 2. The dielectric material has been removed from the toroid core and placed along its outer wall with the entire assembly placed to one side of the waveguide channel. This side-loaded geometry reduces resonance within the toroid and permits additional switching wires to be wrapped on the ferrite. Also, the removal of the dielectric from the core simplifies shifter construction.

Early stages of the contract involved developing a ferrite compound with specifications meeting those of rare earth compositions. Of special concern was reducing the temperature dependency of the ferrite's insertion angle,

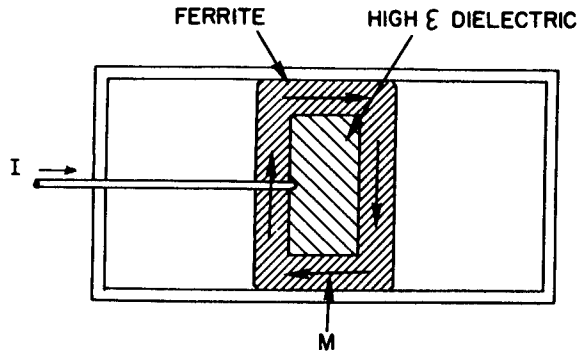

Figure 1 - Non-Reciprocal Latching Phase with Dielectric Loading

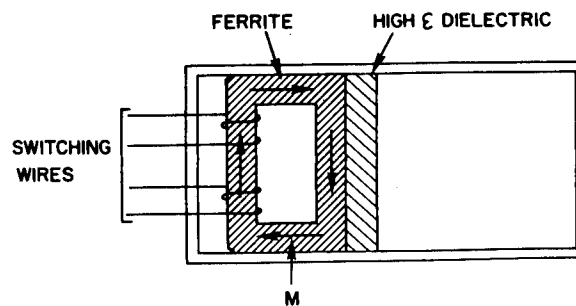

Figure 2 - Non-Reciprocal Latching Phase Shifter - Side Loaded Geometry

since variations degrade antenna accuracy. Varieties of compounds were prepared by introducing donor elements to replace ferrite cations in tetrahedral and octahedral sites. These substitutions were made to influence properties such as dielectric loss, magnetic loss, and magnetic anisotropy. Of the compositions produced, those containing Aluminum, Nickel, or Zinc were the most promising, while those with Gallium, Indium, or Chromium were deemed too costly for production. As a result, a LTZNC-61-10-05-005 composition was chosen for its low temperature coefficient for the insertion phase (1.2 degrees per degree Centigrade average at 40°C).

A second phase of the contract involved forming and testing the toroidal ferrite elements. The ferrite compound was calcined, sintered, and spray dried to achieve a free-flowing powder suitable for compression molding. The powder was isostatically pressed at 15,000 psi around a steel pin using a flexible rubber bag. After firing the elements in a kiln, the toroids were tested for dimensional accuracy. A pin drop test applied to the toroid hole revealed undesirable bowing of the shifters and ultrasonic measurements indicated variations in wall thickness. Two causes of non-uniformity were found to be the bowing of the steel pin and a wide temperature gradient within the firing kiln. Dimensional uniformity will be further studied and refined in a follow-on effort.

BENEFITS

The contractor produced the optimum ferrite composition for the fabrication of phase shifters, an important step in reducing the cost of elements currently made from rare earth garnet. Raytheon also established forming, firing, and evaluation techniques, and brought attention to the difficulty in maintaining a straight toroid hole.

IMPLEMENTATION

The results of this project will be used in follow-on MMT Project 378 3133. A final technical report, number DAAK40-78-C-0082, was disseminated to government agencies and industry.

MORE INFORMATION

Further information may be obtained by contacting Mr. Phillip Ormsby, MICOM, AV 746-4933 or Commercial (205) 876-4933. The contract number was DAAK40-78-C-0082.

Summary Report was prepared by Charles Miller, Manufacturing Technology Division, US Army Industrial Base Engineering Activity, Rock Island, IL 61299.

MANUFACTURING METHODS AND TECHNOLOGY
PROJECT SUMMARY REPORT
(RCS DRCMT-302)

Manufacturing Methods and Technology Projects R77 3452 and R78 3452 titled, "Low Cost Quantity Production Techniques for Laser Seekers," were completed by the US Army Missile Command in June 1980 at a cost of \$5,000,000.

BACKGROUND

The Low Cost Alternate Laser Seeker (LOCALS) is a semiactive optical scanner for use in the HELLFIRE modular missile system, Figure 1. The seeker is comprised of two subassemblies: the seeker head, consisting of a biaxial gyro-stabilized optics assembly within a protective transparent dome, Figure 2; and the electronics unit which generates positioning signals to keep the detector aligned with the target. Both the optics and electronics subassemblies are complex units, costly to manufacture, and are troubled by low yield. Since all three Services employ laser seekers, there is need to minimize production cost by configuring a Tri-Service unit with sufficient design flexibility to accommodate a variety of missile programs. One approach is to integrate components of the Army-developed SMITHS seeker head with COPPERHEAD subassemblies to achieve a more universal, economical design. Such a program requires identification of high cost processes, component prototyping, and a pilot production run.

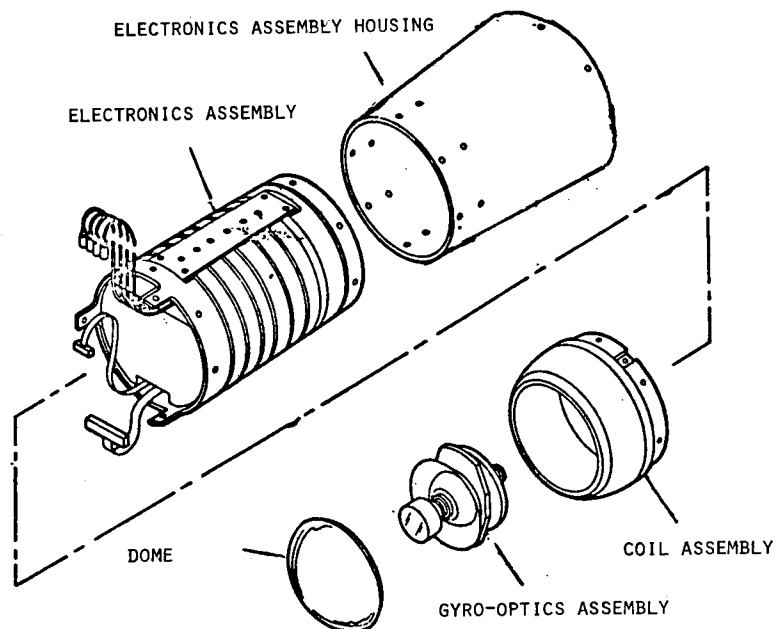

Figure 1 - Low Cost Alternate
Laser Seeker (LOCALS)

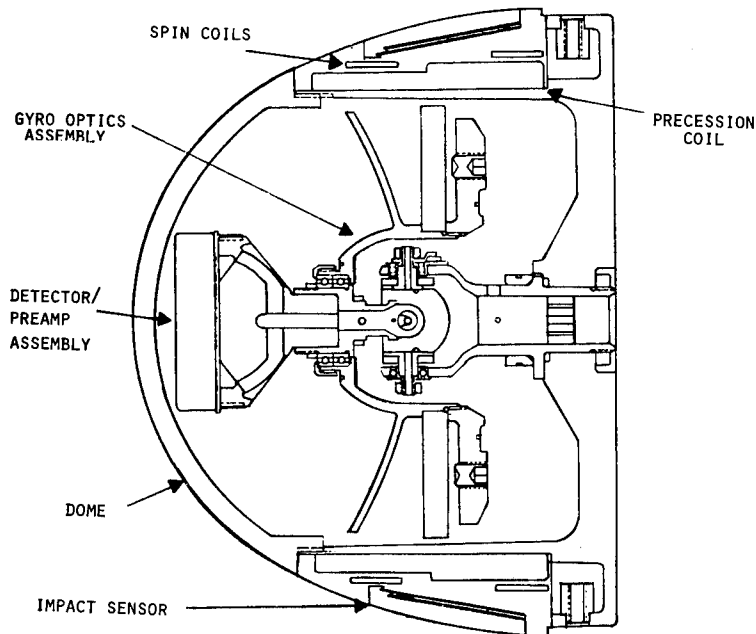

Figure 2 - Seeker Head Configuration

SUMMARY

The objective of this project was to develop production methods for a low cost seeker by integrating the COPPERHEAD electronics with the SMITHS gyroscopic seeker head. Martin Marietta won a multi-phase contract for process analysis, component prototyping, and pilot production run.

The first and second phases identified critical areas in SMITHS and COPPERHEAD seekers and combined shared production steps. The following production improvements were made on the existing assemblies:

1. Detector sensitivity was increased by replacing the occluding detector supports on the SMITHS unit with a more transparent immersion lens support. Improved electromagnetic interference protection was afforded by the use of lossy line filters between the detector and preamplifier and twisted-pair transmission lines.

2. Production of the aspheric aluminum mirror was simplified to reduce its cost. The addition of an outer stiffening rim reduced flexure during machining and anodization produced surfaces comparable to chromium-plated mirrors but without the associated expense. Diamond turning of the surface was retained; and, with the other quality improvements, final polishing was unnecessary.

3. New large scale integration (LSI) circuitry was developed to perform tri-service code acquisition and acknowledgement functions not present in COPPERHEAD hardware. Also, the decoder memory circuit was changed from octal operating logic to the tri-service format.

4. Other improvements include an advanced alignment procedure for the detector assembly and an alignment fixture for the gimbal rings. Superior shaft speed encoders were made by replacing noisy electrical contacts with LED/phototransistor sensors.

Phase III began by correcting problems encountered in spin bearing installation, shaft magnetic pole alignment, and detector support fabrication. In addition to implementing several design improvements, the final plan consolidated common COPPERHEAD/SMITHS operations in circuit board assembly areas. The successful effort concluded with a demonstrated production rate of 25 seekers/month and delivery of 54 units.

BENEFITS

A tri-service laser seeker head was production engineered and reconfigured to permit more cost-effective manufacture. A pilot run of seeker heads was available for test.

IMPLEMENTATION

The results of this successful effort have been incorporated into the basic design and manufacturing plan of the HELLFIRE missile with substantial savings validated. Final technical reports have been distributed to government agencies and industry.

MORE INFORMATION

Additional information may be obtained from the project officer, Mr. Bobby C. Park, MICOM, AV 746-7057 or Commercial (205) 876-7057. The contract number is DAAK40-77-C-0179. Martin Marietta's report is number OR 14,963-2.

Summary Report was prepared by Charles Miller, Manufacturing Technology Division, US Army Industrial Base Engineering Activity, Rock Island, IL 61299.

MANUFACTURING METHODS AND TECHNOLOGY
PROJECT SUMMARY REPORT
(RCS DRCMT-302)

Manufacturing Methods and Technology Project R78 3253 titled, "Manufacturing Methods for Thin-Film Field Emission Cathodes," was completed by the US Army Missile Command in December 1980 at a cost of \$175,000.

BACKGROUND

Thin film field emission cathodes (TF FEC) for electron tubes have been under development for ten years as new methods for making arrays of miniature cones as field emitters evolved with advances in photolithography and thin film technology. A typical field emission cathode and surrounding gate are shown in Figure 1. The device is composed of a 1.5 micron-high molybdenum cone separated from a film of gate molybdenum by a layer of silicon dioxide, all on a silicon wafer. In operation, a potential of only 100 to 300 volts applied to the gate pulls electrons from the tip of the emitter cone and supplies a cloud of them to the tube.

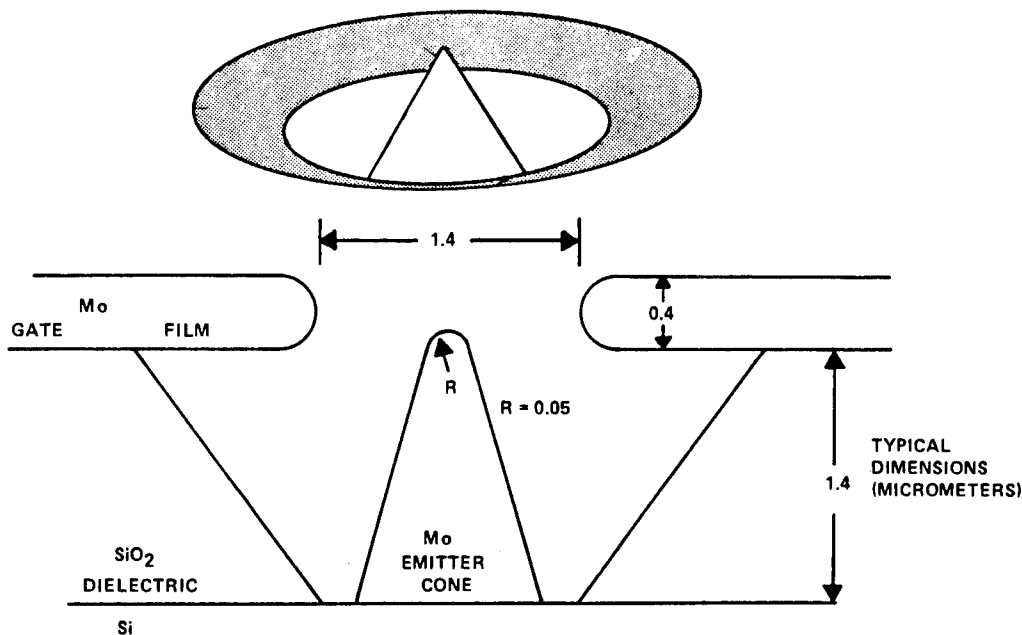

Figure 1 - Idealized Cone Configuration

The TF FEC design has several advantages over thermionic devices: current densities greater than 10 A/cm^2 can be achieved without sacrificing tube life and low operating voltage makes the unit less susceptible to ionization damage from ambient gas. Furthermore, the absence of a cathode heater greatly reduces power requirements and eliminates visible radiation.

Another defect, cracking and peeling of the gate layer, is shown in Figure 3. The poor quality of the aluminum cone mask and low strength of the molybdenum deposits rendered the TFFEC device unusable. These problems were unresolved when the contract ended and will be addressed in a future MMT project.

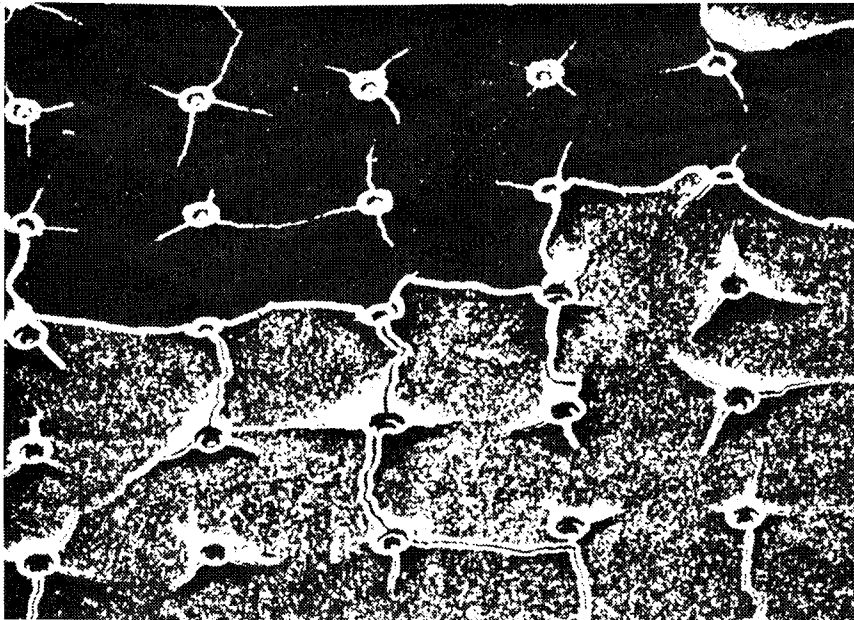

Figure 3 - Cracking and Peeling of Molybdenum Gate Layer Caused by Stresses

BENEFITS

Although this project failed to produce usable thin film emission cathodes, lithographic and etching techniques were significantly refined. Photomicrography demonstrated sufficient resolution and offered more convenience than electron-beam techniques. The project also showed gas etching to be superior to acid etching in the prevention of surface contamination.

IMPLEMENTATION

A final technical report was distributed to government agencies and industry. No further implementation of this technically unsuccessful contract is planned, but work on thin-film cathodes is continuing in Project R79 3253.

MORE INFORMATION

Further information may be obtained from the project officer, Mr. Al Abston, MICOM, AV 746-1740 or Commercial (205) 876-1740, or from Mr. W. K. Paterson, MICOM, AV 746-2710 or Commercial (205) 876-2710. The contract number was DAAK40-78-C-0231.

Summary Report was prepared by Charles Miller, Manufacturing Technology Division, US Army Industrial Base Engineering Activity, Rock Island, IL 61299.

MANUFACTURING METHODS AND TECHNOLOGY
PROJECT SUMMARY REPORT
(RCS DRCMT-302)

Manufacturing Methods and Technology Project R78 3436 titled, "Development of Ceramic Circuit Boards and Large Area Hybrids" was completed by USA Missile Materiel Readiness Command in March 1981 at a cost of \$325,000.

BACKGROUND

Along with the need for more capability in electronic control systems has come the need for the development of more complex micro-components and a requirement for denser packaging systems. The most practical means of satisfying the performance, packaging density, and interconnect problems for military circuits is to use large scale hybrid microcircuits. Since large hybrid microcircuits are relatively new, their configuration and production processes are not fully developed and the devices are unnecessarily expensive.

SUMMARY

The purpose of this effort was to refine the manufacturing processes so that less expensive and more reliable devices can be produced. Two approaches to the production of large scale hybrid circuits were initiated. The first approach was to produce the hybrid circuit on a substrate and then seal it in a container for installation on a circuit board. This is similar to the conventional method used for single chip microcircuits. The second method used a large substrate in place of the circuit board. The individual chip carriers were mounted on the substrate and then the assembly was coated with an environmentally resistant glass coating. While the second method appeared more efficient, it was also a higher risk approach since it deviated more from conventional manufacturing procedures and had one less barrier between the active elements and the environment.

The first method (hybrid in a container) was pursued by General Dynamics and used the STINGER/POST electronics for test samples. Three of the project's five objectives were completed while the remaining two, fabrication and test, were written into the follow-on FY80 effort. The completed portions included a survey of industry to ascertain trends and techniques.

The second method of hybrid manufacture (encapsulated substrate) was performed by Martin Marietta. Martin also performed an industry survey, but it was directed to actual production data such as materials, design guidelines, yield and cost. A spin and precession assembly used on the Navy's Guided Projectile Program was selected for verification. The resulting circuit consisted of two conductor layers using gold for all interconnects and platinum-gold for solder pads and associated short runs. A glass overcoat was provided over all areas except the solder pads. The ceramic chip carriers were then reflow soldered to the pads. The need for general conformal coating will be determined during environmental testing. Ten of these circuit boards,

Figure 1, were fabricated and subjected to functional and environmental tests. Problem areas uncovered were not too numerous and did not indicate technological barriers. The follow-on FY80 portion will be directed toward production of prototype units.

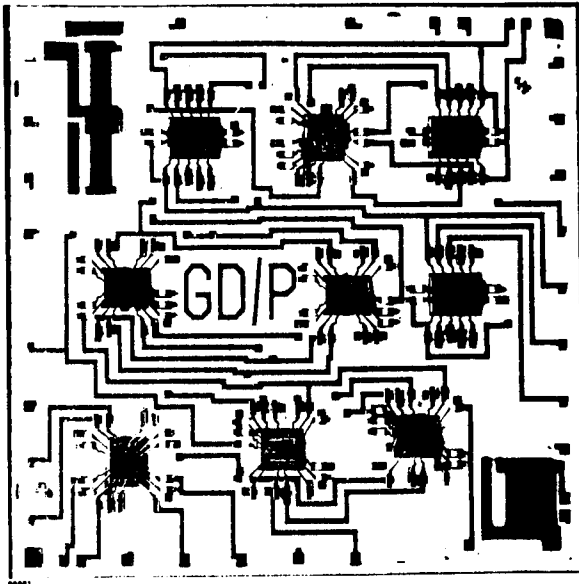

Figure 2 - Hybrid Microcircuit Assembled Using BTAB Technology

BENEFITS

The materials and production procedures, and repair and testing methods for two approaches to manufacture large area hybrid circuits are being developed. The more conventional "circuit in an enclosure" method has advanced to the point of breadboard fabrication. The alternate "coated board" method has advanced to the point of pilot quantity production.

IMPLEMENTATION

At the completion of the FY80 effort, implementation is planned for circuitry used in the Army STINGER missile and the Navy guided projectile program.

MORE INFORMATION

Additional information may be obtained from Mr. P. Wanko, US Army Missile Command, Redstone Arsenal, Alabama, AV 746-7097 or Commercial (205) 876-7097.

Summary Report was prepared by Hal Weidner, Manufacturing Technology Division, US Army Industrial Base Engineering Activity, Rock Island, IL 61299.

INSPECTION AND TEST

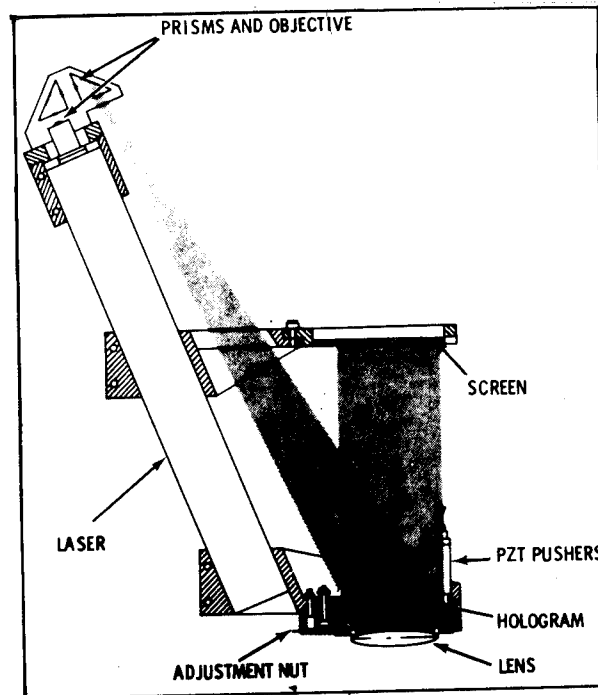

OPTICAL HOLOGRAPHIC TEST EQUIPMENT

MANUFACTURING METHODS AND TECHNOLOGY
PROJECT SUMMARY REPORT
(RCS DRCMT-302)

Manufacturing Methods and Technology projects 1 77 7144 and 1 78 7144 titled "T700 Engine Nozzle In-Process Inspection" was completed by the US Army Aviation Readiness and Development Command in June 1981 at a cost of \$148,000.

BACKGROUND

The T700 Engine high pressure turbine nozzle segments are manufactured by an advanced casting technique to form internal cooling passages. Complex film cooling holes are then drilled by Electrical Discharge Machining (EDM) and electrostream. These segments are joined by brazing and welding techniques. Often these cooling passages and holes are restricted or blocked when these segments are joined. If these cooling passages or holes are restricted or blocked, the engine may suffer severe damage. Current cooling flowpath inspection methods include the use of pin wires, x-ray, water and airflow testing; each of these are labor intensive and costly and do not assure the required quality.

SUMMARY

The objective of this effort was to develop and fabricate an T700 engine high pressure nozzle in-process inspection system. This system would include the capability to measure both cooling flow rates using a computerized infrared technique and the exit areas using a computerized optical image analysis technique.

The Infrared (IR) Measurement System, Figure 1, is based on computerized analysis of infrared thermal transient images of airfoil surfaces following a sudden injection of a cooling fluid into the airfoil. The practicality of detecting blocked surface holes was demonstrated on a very small number of parts, but the high signal-to-noise ratios obtained indicated that excellent blocked hole detection performance can be expected on larger samples of parts. The applications of infrared inspection to predict airflow rates for 47 nozzle segments run twice each (94 runs total) yielded a root-mean-square prediction error of approximately 3.3% of the mean airflow rate. While the results of this effort does not meet current production accuracy requirements, there are certain areas that can be improved that will improve the accuracy of this application of the infrared inspection technique. These areas are the heat transfer medium, use a gas rather than a fluid, data acquisition, use direct digitization of output rather than video tape and the inspection criteria should be in terms of infrared variables rather than airflow rates.

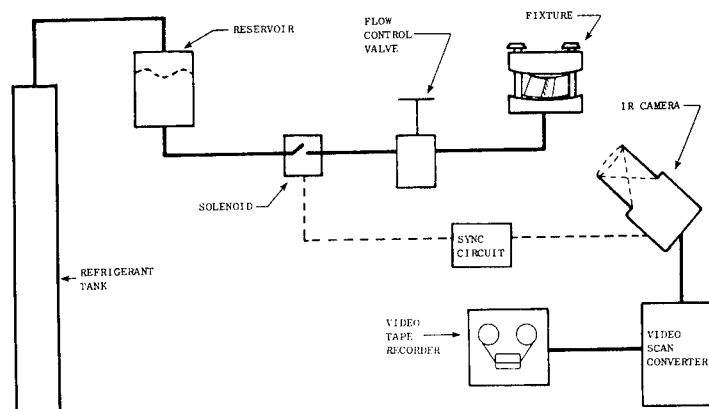

Figure 1 - Laboratory Configuration for Infrared Inspection

The automated optical measurement system consisted of a fixture, Figure 2, scanner and image analysis system. The fixture positions and illuminates the nozzle assembly and manipulates a mirror and lens arrangement to view each passage at two predetermined angles. Each of the two views represents approximately one half of the passage area to be measured. The scanner, a high linearity, low drift, senses the images which are then digitized and processed by a image analysis system that determines the observed exit area measurements. The initial results yield a predicted two sigma repeatability (with 95% confidence) of 0.05% for a nozzle assembly with 24 passages. Data comparison between the image analysis technique and the traditional choked flow method yielded a correlation coefficient of +0.99 for a sample of five assemblies.

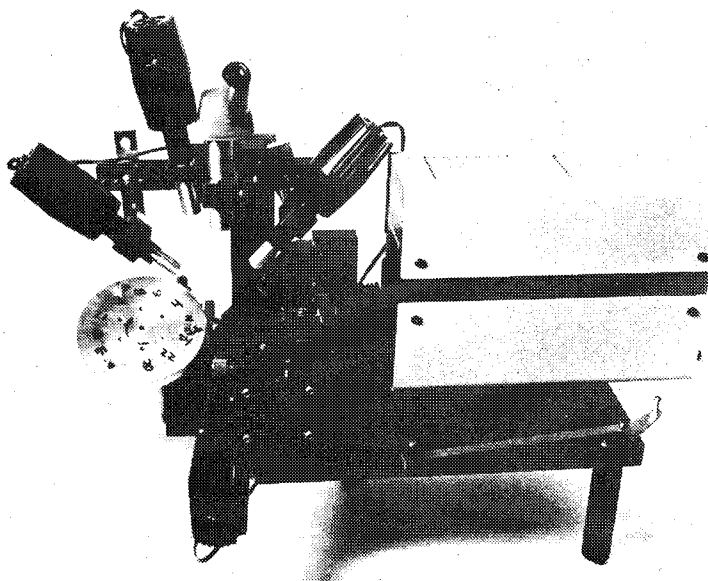

Figure 2 - Overall View of Fixture

BENEFITS

The results of this effort demonstrated the practicality, even though the accuracy requirements were not achieved, of using infrared inspection for blocked hole detection and airflow rates estimated using infrared inspection data. Also, the Optical Measurement System is a practical alternative to the choked flow system.

IMPLEMENTATION

The Infrared Measurement System results of this effort are being used in the development of the IR Module of Integrated Blade Inspection System MMT Project No. 180 7371. The Optical Measurement System development is currently being considered for implementation by the engine manufacturing.

MORE INFORMATION

Additional information on this project is available from P. W. Rolston, AMMRC, AV 955-3555 or Commerical (617) 923-3555.

Summary report was prepared by Del Brim, Manufacturing Technology Division, US Army Industrial Base Engineering Activity, Rock Island, IL 61299.

MANUFACTURING METHODS AND TECHNOLOGY
PROJECT SUMMARY REPORT
(RCS DRCMT-302)

Manufacturing Methods and Technology Project 380 3169 titled, "Automatic Optical Inspection of Printed Circuit Boards and Components (CAM)," was completed by the US Army Missile Command in June 1980 at a cost of \$90,000.

BACKGROUND

Inspection cost of several major missile systems (e.g., HELLFIRE, Pershing II, SAM-D, and SPRINT) have soared during the production phase due in part to the time-consuming task of inspecting printed circuit board (PCB) assemblies. Prior to this effort, the Government and commercial industry normally inspected these assemblies visually; this proved to be very tedious, inefficient, and costly when the production quantities were extremely large. To solve this problem, a reliable, low-cost automated inspection system was needed to detect common defects such as: excess solder, lack of solder, solder bridges, improper lead cutting and bending, and missing or incorrectly oriented parts. Prior effort in this area was performed under Project 377 3169 titled, "Automatic Optical Inspection of Printed Circuit Boards and Components (CAM)," of which this project is a continuation. A prototype system was developed under this prior effort.

SUMMARY

The objective of this effort was to develop an automated inspection system with operating procedures which could detect the majority of problems encountered in PCB manufacturing.

The prototype system that was developed consisted of a very low power helium neon laser, an X-Y moving galvanometer scanner, and several folding mirrors. When the laser scanner is operating, it scans a preprogrammed path over the lead side of a PCB. While scanning the board, a unique shadow signature is detected by the silicon photo diodes located at the optimum geometry, see Figures 1 and 2. This signal is processed and evaluated by a minicomputer to determine whether the components are as specified.

To prove out the developed scanner system, the prototype was incorporated as an integral part of three production lines; with the intention of demonstrating its capability to function in various production environments.

As a result of the initial demonstration, the inspection scanner system proved that it can be used to simultaneously detect major defects, such as solder bridges and missing components, thus expediting the examination of PCBs. The system demonstrated is capable of functioning at any point in the production process where the maximum cost benefit can be realized.

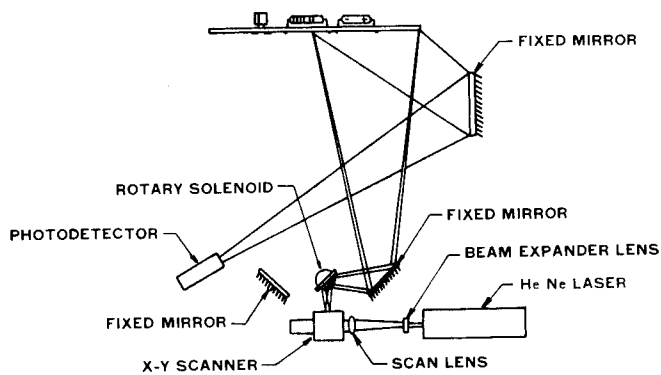

Figure 1 - Scanner Optical Path

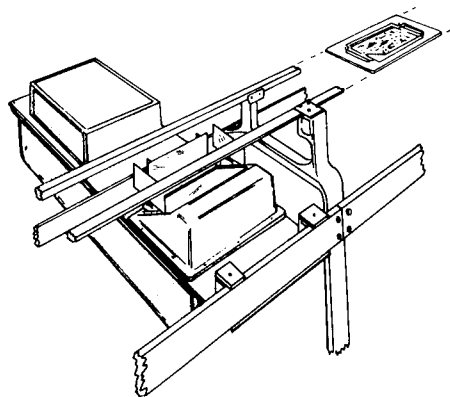

Figure 2 - On Line Scanner Configuration

The instruments comprising the PCB inspection system are designed to automatically inspect bare and/or populated PCB for defects. As a preventive measure, the system is capable of supplying feedback information which potentially prohibits the manufacturing and/or transfer to faulty assemblies. The system, in addition to all other features mentioned, has automatic sorting capabilities. Also, resulting from the demonstration, the system proved that it was capable of inspecting PCBs having approximately 60 components in 2-1/2 seconds where the production rate was established to be 20 boards per minute. For a production illustration of the initial demonstration refer to Figure 3.

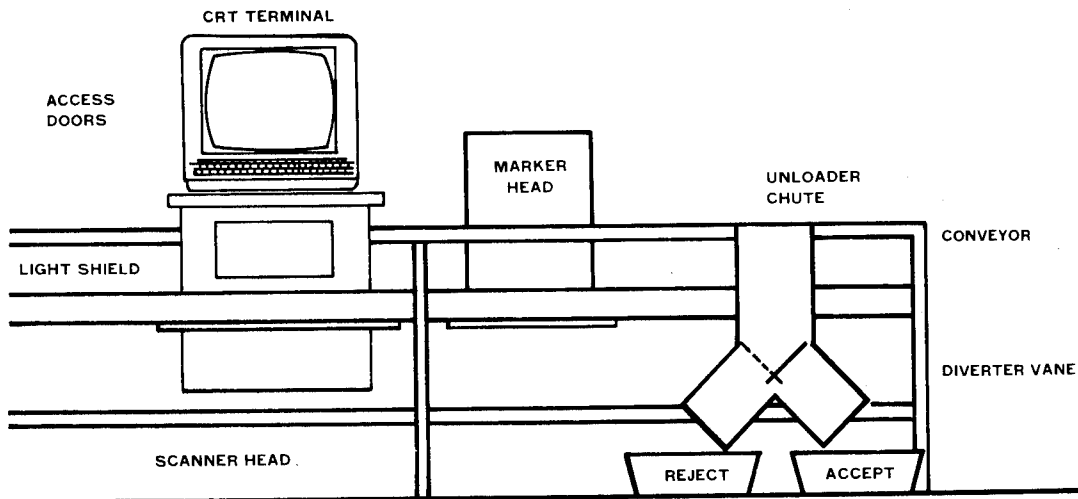

Figure 3 - Typical Production Set-Up

BENEFITS

The capability of inspecting PCBs using a rapid, and cost efficient system was developed. Based on the production prototype demonstration, the laser increased productivity and decreased labor cost three ways. First, it replaces the checker at the end of the insertion line who inspected to separate the acceptable and rejected PCB assemblies. Secondly, since it identifies defects to the component level, it reduces screening time for rework of defective assemblies. Thirdly, the scanner greatly reduces the number of defective assemblies passed on the wave soldering line (to the next operation) which at times is as high as 6 to 8 percent. This eliminates much of the rework previously required after soldering, not only decreasing cost, but also increasing reliability.

IMPLEMENTATION

Initially, the prototype laser system was demonstrated at Chrysler's Huntsville Electronics Division to verify the capabilities of the system. Based on the scanner performance on various production lines, Chrysler also plans to use the system on three of its automatic component insertion lines. In addition, Chrysler plans to sell the system to other electronics manufacturing companies.

MORE INFORMATION

For additional information consult the final technical report titled, "A Laser Scanner for Evaluation of Printed Wiring Boards," Contract Number DAAA40-77-C-0189. Detailed information may be obtained from Mr. Robert L. Brown, MICOM, AV 746-5742 or Commercial (205) 876-5742.

Summary Report was prepared by T. Locke, Manufacturing Technology Division, US Army Industrial Base Engineering Activity, Rock Island, IL 61299.

MANUFACTURING METHODS AND TECHNOLOGY
PROJECT SUMMARY REPORT
(RCS DRCMT-302)

Manufacturing Methods and Technology Project 575 3077 titled, "Production Methodology For The Validation of Electronic Fuzes" was completed November 1980 by US Army Electronics Research and Development Command - Harry Diamond Laboratories at a cost of \$250,000.

BACKGROUND

During the many years of the Army's electronic fuze development, a requirement has existed for incorporating production technology as early as possible in the development phase. The introduction of production technology early in the development phase would not only reduce production costs but would reduce the overall lead time to field production fuzes. To accomplish this, a Prototype Validation (PV) Facility would be required. This facility would have the capability to fabricate and test prototype fuzes using production equipment. The use of this facility would allow fuze performance verification and producibility to be achieved prior to type classification and the award of production contract.

SUMMARY

This effort was initiated to determine whether the PV facilities concept was achievable. This facility, as perceived, would consist of ten functional areas: Electromechanical, Semiconductors, Fuze Power Sources, Printed Wire Board, Electronic Board Assembly, Thick Film Hybrid Microelectronic, Inspection & Test, Environmental Test, Mechanical Fabricating and Computer Support. The primary objectives of the effort were as follows:

- Identify the various fuze manufacturing and inspection technologies and capabilities for each of the ten functional areas.
- Select the most promising technologies and finalize a production and inspection concept for each functional area.
- Develop the equipment quantities and specification for the selected production and inspection concept for each functional area.
- Develop a PV facilities plan and requirements (equipment, layout, schedules and costs) to support APA 4911 budget request.

All of the above objectives of this effort were realized. The results of the effort generated the necessary documentation to support the submission of a Military Construction Army (MCA) program for the prototype validation facility.

BENEFITS

The potential benefits to be realized by the Army from the results of this effort, once implemented, will be more reliable fuzes at a reduced cost.

IMPLEMENTATION

The results of this effort are available for implementation. The approval of the PV facility MCA project line item titled, "Research and Engineering Support Annex" was received up to the level of the Office of Secretary of Defense. The project was included in the FY79 and 80 MCA budgets. The level of approval resulted in the Corps of Engineers awarding funding for the architectural design. Unfortunately, in each of the two fiscal years, economic restraints and demands of programs having higher priority deferred the start of construction. At this time, the project has been deleted from the MCA listing and its future is uncertain.

The PV facility concept, incorporating production methods into prototype design and validation, is still viable, even though the concept will not be carried out in a thorough, formalized manner in a dedicated facility. The ordnance community, as a result of this effort, is aware of the problem and will, as much as possible, consider and incorporate production - compatible materials, methods and designs into the fuze prototype development phase as suggested herein. The final technical report, HDL-SR-80-11, titled, "Production Methodology for the Validation of Electronic Fuzes" was distributed in November 1980.

MORE INFORMATION

Additional information on this effort may be obtained by contacting J. Furlani, ERADCOM, AV 290-3124 or Commerical (202) 394-3124.

Summary Report was prepared by Del Brim, Manufacturing Technology Division, US Army Industrial Base Engineering Activity, Rock Island, IL 61299.

MANUFACTURING METHODS AND TECHNOLOGY
PROJECT SUMMARY REPORT
(RCS DRCMT-302)

Manufacturing Methods and Technology Project R78 3075 entitled, "Infrared Testing of Printed Circuit Boards and Microcircuits" was completed by the US Army Missile Command in August 1980 at a cost of \$335,000.

BACKGROUND

The intent of this project was to develop the equipment and methods for thermally testing circuit boards. Certain types of flaws such as poor solder joints, some parts that are out of specifications and poor heat sink performance can result in higher than normal power dissipation and therefore, should be detectable by thermal scanning techniques. These marginal conditions are not detectable by standard electrical tests and if undetected they result in degraded field reliability.

SUMMARY

Components for the thermal scanning system were to a large extent commercially available equipment modified for these particular tasks. It consists of three basic units: a camera, a digital image processor, and a computer. The camera scans the circuit board and provides an analog signal whose amplitude is proportional to the temperature of the spot being scanned. The field of view is either 5 in. x 4-1/2 in. or 1.1 in. diameter (with the close up lens). Image quality is 512 x 512 lines per raster. The camera produces an analog signal that is digitized and stored in the computer. Typically this scan is then compared to a previously stored standard and values that deviate by more than a predetermined amount are flagged for a more detailed study.

System operation is interactive with system generated cues to assist the operator. Software available consists of a main program and 11 subroutines or subprograms for providing options. The options available are:

- a. Recording a thermogram (512 x 512 Pixels).
- b. Computing a composite thermogram.
- c. Test.
- d. Displaying (on the Cathode Ray Tube [CRT]) a thermogram.

- e. Recording a compressed thermogram (64 x 64 Pixels).
- f. Computing a compressed thermogram.
- g. Test-Compressed.
- h. Display a compressed thermogram..
- i. Alignment test..
- j. Tolerance change..
- k. Terminate the program..

The results of a trial may be displayed on the CRT or for more detailed analysis or documentation, a hard copy may be produced. Most of the testing can be performed by a person who is not highly trained in either electronics or this particular equipment, but it is necessary that a more highly trained person be available for setting up the standards and for unusual trouble shooting situations.

Theoretically all components can be thermally tested, however for devices with low dissipation this is not practical. The most successful testing was for substrate bonding on hybrid circuits, matched transistors, improper heat sink mounting and some plated thru holes on circuit boards.

BENEFITS

A set of equipment for detecting certain types of incipient and actual failure modes by thermal scanning is now available.

IMPLEMENTATION

The equipment is currently at Hughes where it is being used for checking Hybrid Circuits and bare printed wiring boards. Installation of the system at Air Force Logistics Centers has also been suggested.

MORE INFORMATION

Detailed information for this testing system is available in the final report titled, "Infrared Testing of Printed Wiring Assemblies and Hybrid Microcircuits" dated November 1979, Contract No. DAAK40-78-C-0276. The project officer is Mr. Gordon Little, US Army Missile Command, AV 746-3848 or Commercial (205) 876-3848.

Summary report was prepared by Hal Weidner, Manufacturing Technology Division, US Army Industrial Base Engineering Activity, Rock Island, IL 61299.

METALS

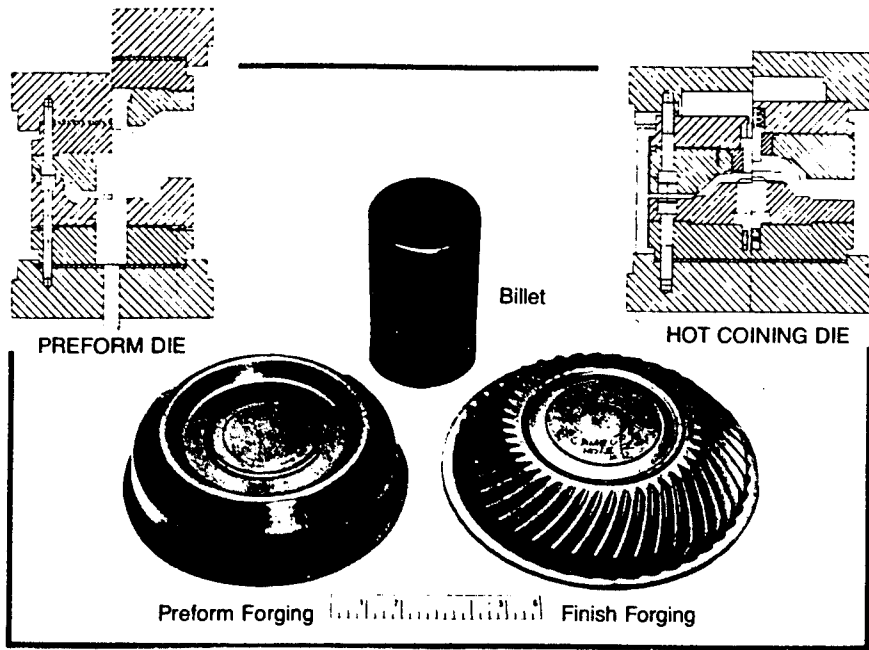

TWO-HIT FORGING PROCESS

MANUFACTURING METHODS AND TECHNOLOGY
PROJECT SUMMARY REPORT
(RCS DRCMT-302)

Manufacturing Methods and Technology Projects 174 8148, 175 8148, and 176 8148 titled, "Processing of Advanced Gear Materials" was completed by AVRADCOM in January 1981 at a cost of \$542,000.

BACKGROUND

With increasing power loads, service requirements have become more stringent and newly developed materials must be utilized for transmission and other gear applications. However, processing information which would make the material amenable to large scale production is lacking. The purpose of this project was to establish the processing necessary to cope with section size, configuration, and service requirements in the manufacturing environment.

SUMMARY

This effort was accomplished in three phases. The first phase (FY74) involved the establishment of test gear dimensions, frequencies and load ranges. It also involved the selection of materials to be processed (AISI 9310 and Vasco X-2) and the selection, acquisition, and validation of the four square gear testing dynamometer. The second phase (FY75) involved the fabrication, heat treatment, and carburization of test gears and rolling contact fatigue specimens, using the AISI 9310 and Vasco X-2 gear steels. Phase three (FY76) evaluated and compared the two gear steels with respect to rolling contact fatigue (RCF) single tooth bending fatigue (STBF), and four square dynamometer testing (FSDT). The Vasco X-2 was tested with two types of carburizing heat treatments: The Boeing Vertal proprietary gas carburization and the AMMRC vacuum carburization specification.

The following results were experienced:

- a. Simultaneous assessment of AISI 9310 and Vasco X-2 (pins and spur gears) was conducted at both AMMRC and the International Harvester Company in RCF, STBF, and FSDT. Vasco X-2 pins and spur gears subjected to vacuum carburization did not initially meet the AMMRC specifications after several attempts. However, work subsequent to this project has met with success on the X-2 pins and success with spur gears is now anticipated. Results of the testing will be detailed in a technical report due to be published in March 1982.
- b. A fiber optic system which permitted viewing the spur gear tooth face while mounted in the four square gear dynamometer was proven successful.

Pitting on the gear tooth face has been detected in the very early stages without the need to dismantle the gears. Polaroid photographs of the gear tooth face have been routinely obtained at a remote site external to the gear box. Several unsuccessful attempts were made to view the gear tooth while the gears were running, by replacing the light source with a strobe light; however, oil splashing on the gears obscured the view.

BENEFITS

The benefits derived from this program are:

a. Results show that increased pitting fatigue life (hence increased load carrying capability) can be obtained with the gas carburized Vasco X-2 as compared to the AISI 9310.

b. Testing of the Vasco X-2 in both pin and spur gear configurations has afforded the additional benefit of possibly using rolling contact fatigue data to predict pitting fatigue life of gears. Utilizing this technique would reduce the need to test many gears to assess performance.

c. Without dismantling the test rig, AMMRC has successfully monitored pitting failure evolution on the gear tooth face, utilizing a fiber optic system. Downtime of the test rig was thereby reduced.

IMPLEMENTATION

A final technical report covering this three-year effort, being prepared by International Harvester Company, is planned for distribution in March, 1982. Publication of this report was delayed in order to include the results of subsequent additional work on the vacuum carburization of Vasco X-2. Technology transfer has been accomplished through the medium of an abstract, describing the work performed on the rolling contact fatigue life of AISI 9310 and Vasco X-2, submitted to the International Symposium on Rolling Contact Fatigue of Bearing Steels.

MORE INFORMATION

Additional information may be obtained by contacting Mr. R. Lamothe at AMMRC, AV 955-5201 or Commercial (617) 923-5201.

Summary Report was prepared by Kenneth Bezaury, Manufacturing Technology Division, US Army Industrial Base Engineering Activity, Rock Island, IL 61299.

MANUFACTURING METHODS AND TECHNOLOGY
PROJECT SUMMARY REPORT
(RCS DRCMT-302)

Manufacturing Methods and Technology projects 475 4557 and 477 4557 titled, "Production Method for High Efficiency Joining of ESR Armor", was completed by the US Army Tank Automotive Command in August 1979 at a cost of \$277,400.

BACKGROUND

Electro-Slag Remelt (ESR) is a recently developed process for manufacturing steel. It provides a steel of very high purity and as such increases the degree of ballistic resistance and the general overall strength properties. Since this material is relatively new, shop practice restraints for weldments must be established in order to reduce adverse effects.

Electro-Slag Remelt armor exhibits superior ballistic performance (high hardness) with good ballistic damage tolerance (sufficient ductility). The compositions and hardnesses of this new armor require different production joining techniques.

SUMMARY

The object of this program was to establish joining processes for ESR armor to permit fabrication on a production bases and obtain information for vehicle design use which will result in superior ballistic protection. Through the use of ESR armor, the vehicle protection-to-weight ratio could be increased.

The difficulty or ease with which ESR processed steel could be welded was explored in the program. Two 72" x 144" x 1" plates of 4340 steel were purchased. The one plate was standard 4340 steel produced by conventional methods while the other was ESR steel. Ballistic test plates were welded in preparation for ballistic testing, see Figure 1. One-half of them did not meet radiographic requirements because of poor weld fusion and porosity. Similar welding procedures on standard armor produced acceptable results.

The Ballistic "H" Plates were shock tested at Aberdeen Proving Grounds, in accordance with Spec MIL-W-46086. Upon impact the plates shattered. The welds remained intact, but the brittle behavior of this heat of ESR steel was catastrophic. The high carbon content, plus the as-welded condition in which the test plates are ballistically tested, is not a combination that can accept shock.

A mock tank hull, consisting of standard homogenous armor, high hardness armor, and ESR armor was fabricated to determine the compatibility of the materials. Radiographic examination showed the ESR welds to be of acceptable quality. Attempts to simulate a repair of the hull were unsuccessful.

MANUFACTURING METHODS AND TECHNOLOGY
PROJECT SUMMARY REPORT
(RCS DRCMT-302)

Manufacturing Methods and Technology Projects 574 6576 and 575 6576 titled, "Application of High Speed Boring For Large Caliber Shell Used With Production Equipment on Improved Conventional Munitions" were completed by the US Army Armament Material Readiness Command in September 1977 at costs of \$140,000 and \$30,000, respectively.

BACKGROUND

New generation large caliber ammunition is being designed to take advantage of the greater strength of modern alloys with design specifications calling for a shell hardness of 50 to 55 on the Rockwell C scale. Boring materials of such hardness results in high tool mortality and low metal removal rates.

The standard method of deep boring large caliber shells is by using a conventional boring bar arrangement on a hollow spindle boring lathe. Although the equipment has the capacity for higher speeds and feeds, the coolant system and tooling are limited. Tool failure, chip disposal, and hole straightness are problems needing attention.

SUMMARY

There were two phases associated with the MMT effort. The objectives of the first phase were to demonstrate shear-forming equipment capabilities and determine minimum shear-forming time to form the undercut in the 155mm, M483 projectile body. Based on the results of shear-forming studies conducted during this phase of the project, it was concluded that shear-forming of the undercut cannot be successfully applied to the manufacture of the 155mm, M483 projectile without taking a rough turn machine cut on the I.D. surface first. This rough turn machine cut eliminated the potential cost savings associated with shear-forming and, consequently, this phase of the project was never implemented.

The objective of the second phase of this effort was to develop a system to bore large diameters and deep holes in alloy steels. Initial studies were conducted on a turret lathe utilizing tooling based on designs successfully used at Watervliet Arsenal. Because the lathe did not have adequate speed and a sufficient variation in feed rate, conclusive tests could not be conducted. With the remaining money, a decision was made to procure a high speed boring machine, see Figure 1, and off-the-shelf Sandvik Ejector Drill tooling to continue with the project. Trials were conducted with a 8-inch M509 Shell at the machine builders plant, but were not successful even though tooling engineers from Sandvik expended considerable effort.

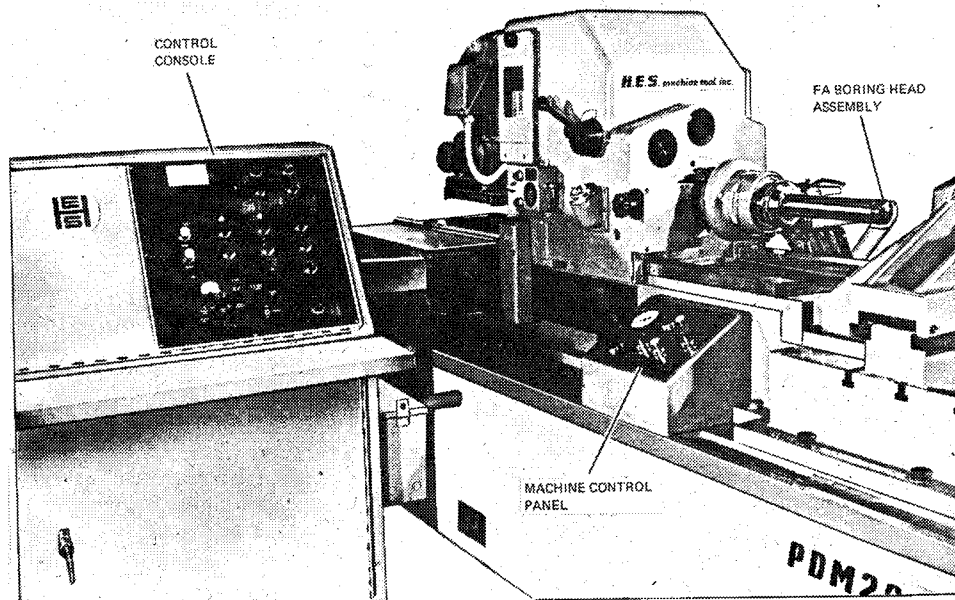

Figure 1 - PDM 200 High Speed Boring Machine

Using the Sandvik Ejector Drill, the machine chips tended to fill the void ahead of the tooling instead of being flushed out as the boring continued. These chips, in the forward part of the shell, then interfered with the drilling action. It was felt that this deficiency could be overcome by the installation of a moveable baffle inside the shell that would precede the tooling through the shell. This concept would, in effect, simulate a solid material application of the ejector drill and, in all probability, provide a mechanism whereby the chips would be flushed back out of the shell. Unfortunately, funds were unavailable to investigate this concept.

BENEFITS

This effort was not successful and so no benefits have accrued to the Army.

IMPLEMENTATION

The equipment developed by this project has not been implemented. Further development is required before implementation may be considered in a production environment.

MORE INFORMATION

Additional information may be obtained by contacting Mr. Henry Lipinski, ARRADCOM, AV 880-3100 or Commercial (201) 328-3100.

Summary Report was prepared by Alan Peltz, Manufacturing Technology Division, US Army Industrial Base Engineering Activity, Rock Island, IL 61299.

MANUFACTURING METHODS AND TECHNOLOGY

PROJECT SUMMARY REPORT

(RCS DRCMT-302)

Manufacturing Methods and Technology Project 577 4410 titled, "Manufacturing Tungsten Penetrators by Taper Swaging," was completed by the US Army Armament Research and Development Command in January 1980 at a cost of \$382,920.

BACKGROUND

The penetrator for the M735 Projectile was to be manufactured by swaging an 18-pound tungsten bar, and then machining it to final form as the 4.7-pound penetrator. It was believed that this low material yield, and the associated high cost and chip recycling problems, could be improved if a near net shape process could be implemented.

SUMMARY

During the FY76 PEP Program, several methods of cold working the penetrator were investigated. Only the "taper swaging" method was shown to be commercially feasible as well as capable of producing a potentially good penetrator.

Under this project, the method was continued at two contractor facilities. Each contractor studied his die and machine interfaces to obtain suitable process parameters. Full-scale tungsten penetrators were made and assembled into 250-grade maraging steel bodies whose properties were known. These projectiles were then ballistically tested at Aberdeen Proving Ground. The results of the tests were inconclusive in that one contractor's output was successful in one test and unsuccessful in the other. The second contractor's output failed to meet effective range requirements on both of the final lot submissions.

BENEFITS

It was learned that tungsten could not be taper swaged to the required properties.

IMPLEMENTATION

Taper swaging of tungsten penetrators was not implemented.

MORE INFORMATION

Additional information may be obtained by contacting Mr. K. Willison at ARRADCOM, AV 880-6288 or Commercial (201) 328-6288.

Summary Report was prepared by Ken Bezaury, Manufacturing Technology Division, US Army Industrial Base Engineering Activity, Rock Island, IL 61299.

MANUFACTURING METHODS AND TECHNOLOGY
PROJECT SUMMARY REPORT
(RCS DRCMT-302)

Manufacturing Methods and Technology Project 577 6678 titled, "Evaluation of Aqua-Quench Under Production Conditions" was completed by the US Army Armament Research and Development Command in September 1980 at a cost of \$300,000.

BACKGROUND

Projectiles heat treated to achieve required mechanical properties are currently quenched in an oil bath as part of the heat treating procedure. Quenching of the hot projectiles into the oil bath causes severe environmental, safety and fire hazards resulting from the smoke and flames associated with this operation. Synthetic, water based quenchants (aqua quench) have become available as a replacement for oil quenchants. A study conducted under MMT projects 573 4114 and 574 4114 involved aqua quench heat treatment of approximately 6000 155mm M107 projectiles which was completed with satisfactory results.

SUMMARY

The objective of this project was to use aqua quench on a full production basis for a trial period of two months to provide assurance that aqua quench can be used in production without the occurrence of problems undiscovered during heat treatment of the pilot quantity. As a secondary part of this project a trial quantity of approximately 2000 155mm M483 projectiles were heat treated using aqua quench to determine if the alloy steels used in this item could be aqua quench heat treated. The projectiles were heat treated using the Houghton Aqua Quench 251 product.

During this project initial production trials were performed at Scranton AAP on the 105mm M107 projectile using the new Holcroft furnaces and the aqua quench process using the 251 product. Problems were experienced in meeting mechanical property requirements using these process parameters. Increased quench bath agitation and lower aqua quench concentration were required to achieve the level of quenching necessary to meet mechanical property requirements. Because process parameters were changed from the previously established limits, it was necessary to perform magnetic particle inspection to provide assurance of no quench cracks. During this testing, projectiles were found with nose cracks that were determined to be quench cracks. Process adjustments using the Houghton 251 aqua quench product were not successful in eliminating the quench cracking problem while maintaining mechanical property requirements. Based on the test results, it was concluded that the Houghton 251 product could not be successfully applied to heat

treatment of the M107 projectile. It was also possible that quench cracks were being experienced using the standard oil quench. To check this possibility, a quantity of 1500 oil quench projectiles heat treated using the old surface combustion furnace, were magnetic particle inspected and no quench cracks were detected.

Polymer base quenchant other than Houghton 251 were investigated to determine if a synthetic quenchant with a slower quench in the critical transformation temperature range was available. Tenoxol, another manufacturer of synthetic quenchant, recommended their UCON HT quenchant as being best for this application. In order to evaluate this product, quench rate curves were obtained using Tenoxol's test equipment to determine the differences in quench rate between Houghton 251, Tenoxol HT and the quench oil being used at SAAP. Oil was found to be the fastest quench medium in the upper temperature range of cooling and moderately slow in the martensite transformation range around 600°F. The Houghton 251 was slower in the upper temperature range and faster in the lower transformation temperature range than the oil.

A polymer quench with a slower quench speed in the lower temperature, martensite transformation region was considered necessary to avoid quench cracking. Since Tenoxol's UCON HT exhibited a faster cooling rate in this critical region than Houghton 251, it was concluded the UCON HT would not eliminate the quench crack problem and that no further work on the 155mm M107 projectile was warranted.

Work on aqua quench heat treatment of the 155mm M483 projectile was conducted at Chamberlain's Waterloo Division. Quench cracking in the rotating band area was experienced using Houghton 251 quenchant. The quench medium was then changed to Tenoxol "B" quenchant. Results using this product were not satisfactory. When parameters were adjusted to meet mechanical property requirements, quench cracking occurred and when parameters were set to avoid quench cracking, mechanical properties did not meet requirements. Tenoxol quenchant "HT" was the next quenchant tested. Problems similar to those experienced with Tenoxol quenchant "B" occurred. In a final attempt to correct these problems, a shield was used in the area of the rotating band to slow down the quench rate in this area and, thereby, hopefully prevent quench cracks. Quench cracking occurred using the shield also and the work was discontinued. It was concluded that water base synthetic quenchant could not be used in heat treatment of the 155mm M483 projectile.

BENEFITS

The results of this project have shown that there are problems associated with water base quenchant for projectile heat treatment. Without this project these problems would have not surfaced prior to their use on a production basis.

The results have also indicated that a complete evaluation is needed before considering synthetic water base quenchant for any other applications.

IMPLEMENTATION

The results of this project are not recommended for implementation due to the problems associated with the aqua quench process. Therefore, no implementation is planned.

MORE INFORMATION

To obtain more information contact the project officer, Mr. D. O. Gustad, AV 880-2522 or Commercial (201) 328-2522.

Summary Report was prepared by Robert Hellem, Manufacturing Technology Division, US Army Industrial Base Engineering Activity, Rock Island, IL 61299.

MANUFACTURING METHODS AND TECHNOLOGY
PROJECT SUMMARY REPORT
(RCS DRCMT-302)

Manufacturing Methods and Technology Project 577 6777 titled, "Development of a Production Process for 105mm XM710E1 Artillery Projectile Metal Parts," was completed by US Army Armament Research and Development Command in January 1979 at a cost of \$397,000.

BACKGROUND

At the inception of this project, projectiles were manufactured by conventional machining techniques. The projectile cavities were cylindrical and the design tolerances were compatible with the processes being used. With the advent of the improved conventional munitions, designs emerged which had fluted cavity contours, reduced tolerances, and elevated physical property requirements. A typical example was the 105mm XM710E1 artillery projectile.

SUMMARY

The objectives of this project were to investigate forming and heat treating techniques and to develop a suitable production process for the manufacture of the 105mm XM710E1 artillery projectile. A reduction in the initial unit cost of this item was anticipated as a result of this effort. Contracts were awarded and considerable activity was completed prior to the decision to cancel the XM710 Program. A final report outlining an "in-theory" process and inspection concept was prepared by the contractor. In this report, further detailed studies, particularly related to tooling, were recommended; however, due to the XM710 cancellation, this project was abandoned and unused funds (\$103,000) were returned to the PM-PBM.

BENEFITS

In the event that a design similar to the XM710 is developed, the contractor's final report may have application as a starting point for future actions.

IMPLEMENTATION

Project results are available for implementation to the extent outlined, but no particular application is currently anticipated.

MORE INFORMATION

Additional information may be obtained by contacting Mr. R. Phol, ARRADCOM, AV 880-3121 or Commercial (201) 328-3121.

Summary Report was prepared by K. Bezaury, Manufacturing Technology Division, US Army Industrial Base Engineering Activity, Rock Island, IL 61299.

MANUFACTURING METHODS AND TECHNOLOGY
PROJECT SUMMARY REPORT
(RCS DRCMT-302)

Manufacturing Methods and Technology Project 578 6681 titled, "Process Parameters for Production Forming of Projectiles," was completed by the US Army Armament Research and Development Command in July 1980 at a cost of \$600,000.

BACKGROUND

At the inception of this project, conventional forging and drawing practices were used in the fabrication of artillery projectiles and mortar shells. The extensive machining required to achieve the finished product resulted in poor material utilization. The rotary forging and squeeze casting processes appeared to offer a potential for net-shape forming, with minimal subsequent machining required.

SUMMARY

Rotary Forging

Rotary forging trials on the 155mm M483 projectile body were conducted by American GFM Corporation in Steyr, Austria, using preforms supplied by the New Bedford Division of Chamberlain Corporation.

The forging trials were accomplished with a Model SHH19 rotary forging machine designed for oil pipe couplings. The preforms were heated to 2100°F in a gas fired furnace, transported to the loading mechanism of the forge machine, and descaled. The loading mechanism oriented the preform on the centerline of the chuckhead and mandrel, which moved forward, inserting the mandrel in the I.D. of the preform. The loader then released the preform, and the chuckhead, mandrel and preform advanced to the entrance of the hammers. The counterholder then contacted and applied a counterpressure to the preform and chuckhead. The chuckhead, preform and counterholder were brought up to rotational speed and moved through the forging hammers, forming the O.D. and I.D. of the projectile body in one continuous pass of 25 seconds duration. The chuckhead with the forged body on the mandrel was retracted and the finished part stripped from the mandrel. With proper loading equipment, total cycle time was estimated at 32 seconds.

These trials demonstrated that it is technically feasible to rotary forge the M483 body. An economic analysis was performed to compare the rotary forging method with the hot forge and the hot forge, cold draw methods on 1-8-5 and 3-8-5 shift bases. The results are shown in Table 1.

Table 1 - Economic Analysis Results

Process Compared With	Estimated Material Savings, lbs.	Saving Investment Ratio	
		3-8-5	1-8-5
Hot Forge, Cold Draw	10	3.88	1.29
Hot Forge, Cold Draw	6	2.65	.88
Hot Forge	15	2.25	.75
Hot Forge	11	1.57	.52

The most significant finding of this analysis was that the high investment for rotary forge equipment is only justified under full machine utilization conditions.

Squeeze Casting

The Illinois Institute of Technology Research Institute completed a contract to conduct squeeze casting feasibility studies on the 81mm M374 mortar body and a preform for the 155mm M483 body. Process parameters for squeeze casting of the 81mm M374 Mortar body were investigated using both malleable and ductile iron. Results showed ductile iron to be the better material for squeeze casting of this component.

After material selection, the next phase of the program involved the optimization of process parameters to produce consistently sound squeeze castings.

The final phase of the program examined the reproducibility of squeeze casting the mortar body through a "pilot production" run which employed the optimized process parameters. During the casting of initial pieces, it became apparent that in production, a punch material with better high temperature strength than H13 tool steel would be required. A tungsten or molybdenum alloy might be required to provide the necessary refractory characteristics. Water cooling of the punch would also be required under production conditions.

Inspection of castings produced during this program by X-ray, magnetic particle, and destructive visual examination showed that sound castings with excellent surface quality can be fabricated using the squeeze casting process. However, results of the economic analysis performed on the M374 Mortar body did not show any significant economic benefit to be derived.

BENEFITS

This project has shown that it is technically feasible to rotary forge and squeeze cast munitions shapes. Economic analysis shows rotary forging to be viable at high production rates; but squeeze casting would require much additional work to implement, with minimal cost savings to be achieved.

IMPLEMENTATION

Rotary Forge

There were no facilities planned for manufacturing the 155mm M483 Projectile body; therefore, no recommendation for implementation was made. In the future design of new facilities, rotary forging should be considered.

Squeeze Casting

Squeeze casting was not recommended for implementation.

MORE INFORMATION

Additional information may be obtained by contacting Mr. D. Gustad at ARRADCOM, AV 880-2522 or Commercial (201) 328-2522.

Summary Report was prepared by K. Bezaury, Manufacturing Technology Division, US Army Industrial Base Engineering Activity, Rock Island, IL 62199.

MANUFACTURING METHODS AND TECHNOLOGY
PROJECT SUMMARY REPORT
(RCS DRCMT-302)

Manufacturing Methods and Technology Project 677 7711 titled, "Establish Improved Electropolishing Process for Armament Components" was completed by the US Army Armament Research and Development Command in September 1980 at a cost of \$75,000.

BACKGROUND

Currently, there are no standards, specifications or other definitive documents that accurately describe the electropolishing process used for small caliber gun barrels. The electropolishing process used for this purpose is a metal removal method that eliminates burrs, tool marks and surface stock which results in a smooth surface. This process is, at times, confused with other similar metal removal processes such as electrochemical machining or milling. Although these are metal removal processes, many of these methods do not produce surfaces that are satisfactory for a barrel bore prior to chromium plating. Information which defines process procedures, bath chemistry, surface smoothing limits, burr removal, land contouring and tapering is required. Even though electropolishing has been used for many years in gun tube processing, there are many questions concerning the process parameters necessary to provide the smooth surface finish suitable for chromium plating.

SUMMARY

The objective of this project was to establish and document the process parameters for electropolishing gun barrel materials which can be effectively adopted for small bore gun tubes prior to chromium plating. The project included the evaluation and optimization of electropolishing for various gun barrel materials including Cr-Mo-V gun steel, H-11 and A286 alloy materials. The electropolishing solutions used in this program were a mixture of sulfuric acid, phosphoric acid, chromic acid and water.

Samples of the three alloys were used to evaluate the performance of each of the three electropolishing solutions. The compositions of these solutions are in Table 1. The solution designation is weight percent sulfuric/phosphoric/chromic acids, respectively.

The 20/67 solution produced a mirror-like finish on the gun steel and A-286 alloys. The 5/75/7 solution produced equal or better results but the improvement was not considered sufficient to justify higher costs for the chemicals and for the necessity of frequent discharge and replacement of the solution. The 41/45 solution produced a microscopic etch which resulted in a smooth-dull surface on the gun steel. However, this solution produced a mirror-like finish on the A-286 alloy and it is recommended for use with this alloy

Make Up Chemicals	Solution Identification		
	41/45	5/75/7	20/67
Sulfuric Acid, 96% (ml/l)	410	48.6	210
Phosphoric Acid, 85% (ml/l)	530	914	790
Chromium Trioxide (grams/l)	--	122	--
Water, (ml/l)	60	--	--

TABLE 1 - Electropolishing Solution Compositions

since it is also more efficient in metal removal than the 20/67 solution. The 20/67 and 41/45 solutions produced a smooth-dull finish on the H-11 alloy. A mirror-like finish could only be achieved on this alloy with the 5/75/7 solution, therefore, it is the solution of choice for this alloy.

The most important item for daily solution control during electropolishing is the total acid in the solution. This is controlled by adding or evaporating water from the solution as indicated by simple specific gravity measurements. As metal is dissolved into the solution during use, the specific gravity must increase if the total acid is to remain constant. As metal concentration in the solution builds up, the smoothness and luster of the electropolished metal will diminish gradually. Metal removal in the 5/75/7 and the 20/67 baths is less efficient, based on a weight-amp-hr relationship, than for the 41/45 bath.

Electropolishing evaluations were made on smooth bore H-11 steel cylindrical tubes. The variations in the removal rates indicated the importance of tube positioning in producing a taper in H-11 steel tubes.

The results of this project proved that electropolishing solutions can be effectively adopted for electropolishing gun tubes prior to chromium plating. Electropolishing with a flowing solution through the annular space between the anode and the gun tube developed very little taper in the tube.

BENEFITS

The information and data obtained in this project can be applied to current and future small caliber gun barrels as a means of pretreating the barrels prior to chromium plating. While a quantifiable savings cannot be provided, the use of the process procedure would result in minimizing the waste of scrap barrels/materials.

IMPLEMENTATION

The electropolishing parameters evaluated and established in this program are being documented in a report and will be available to Federal and other production facilities. The methods and procedures established for various gun barrel materials can be adopted for current and future small caliber gun barrel systems.

MORE INFORMATION

To obtain more information, contact the project officer, G. R. Lakshminarayanan, ARRADCOM, AV 880-5746 or Commercial (201) 328-5746.

Summary Report was prepared by Bob Hellem, Manufacturing Technology Division, US Army Industrial Base Engineering Activity, Rock Island, IL 61299.

MANUFACTURING METHODS AND TECHNOLOGY
PROJECT SUMMARY REPORT
(RCS DRCMT-302)

Manufacturing Methods and Technology Projects 677 7716 and 678 7716 titled, "Prototype Production Line for Pressure Phosphate Coating," were completed by the US Army Armament Research and Development Command in June 1980 at a cost of \$192,000.

BACKGROUND

Ninety percent of all ferrous materials used in military weapon components require phosphate coatings used separately or as a base for secondary treatments for corrosion protection. Conventional phosphate coatings have limited corrosion and heat resistance and secondary treatments add excessive material and processing costs.

SUMMARY

The major objective of this effort was to establish a prototype production facility for the processing of a superior corrosion and heat resistant pressure phosphate coating on weapon components.

A new manganese phosphate coating was previously developed at the Rock Island Arsenal. This coating, applied under a positive pressure, and at temperatures in excess of 212°F, can provide a significant increase in corrosion protection and heat resistance at temperatures up to 450°F. Improvements in the process were made during the execution of these projects to eliminate the need for an autoclave and to enable the process to operate in an open tank with steam coil heaters.

The phosphate coating process was modified by increasing the metal content from about 0.4 percent to 1.0 percent, and decreasing the coating temperature from about 216°F to 200°F. Solutions were made by reacting electrolytic manganese metal with phosphoric acid. This reaction would continue until the free acid remaining was low enough for the solution to be used without further chemical additions. These solutions were free of precipitated salts.

The next objective was to develop, evaluate, and establish a prototype production system for producing high temperature, manganese phosphate coatings on ferrous materials. The coating solution contains dissolved manganese phosphate salts which are consumed during the coating process. Replacement of these salts was accomplished by adding a concentrated solution of manganese phosphate. A concentration of five percent was selected because at about six percent metal, some precipitate formed. Early in the program a series of stock solutions was prepared with manganese concentrations

ranging from one to fourteen weight percent. Table 1 shows data for these different solutions.

Table 1 - Stock Solutions of Manganese Phosphate Prepared for Evaluation

Percent Metal	Weight of Reactants, g/l		Precipitate Formed	pH of One Percent Solution (a)	Precipitate Analysis, percent	
	Manganese	Phosphoric, 83% Acid			Mn	H ₃ PO ₄
1	11.5	55	No	2.45	--	--
2	23	110	No	2.40	--	--
4	44	220	No	2.35	--	--
6	65.8	330	Yes	2.30	--	--
8	87.3	440	Yes	2.30	35.1	58.5
10	110	550	Yes	2.30	--	--
12	148	660	Yes	2.55	33.69	59.2
14	126	770	Yes	2.07	--	--

(a) After diluting clear solution to a concentration of one percent metal.

Control of free acid in the manganese phosphase solution is very important. The free acid was controlled by reacting the solution between coating cycles with electrolytic manganese metal. The best corrosion resistant coating was applied only when the free acid was in the pH range of about 3.0 to 3.5. Free acid is defined in this effort as the number of ml of 0.10 normal sodium hydroxide solution needed to raise the pH of 5 ml of the coating solution to 3.2.

The equipment was operated frequently for two months to establish confidence that the process could be controlled. Comparisons show that more free acid is consumed than is generated by chemical dissolution of the steel. It appeared that if the loading area/unit volume was selected correctly, then the free acid content would not change and the process could be carried out with little delay between batches.

With the prototype equipment used during this program, batch-type coating operations were carried out at 200°F for 45 to 60 minutes. Between batch-coating cycles, the solution was cooled, manganese phosphate concentrate added, and the solution treated with manganese metal to remove the excess free acid generated during the coating step. A continuous sludge removal device, using a pump and a settling chamber, was used to remove the sludge from the solution. The sludge was recycled as manganese phosphate after dissolving it in phosphoric acid.

BENEFITS

The increased heat and corrosion resistance afforded by the manganese phosphate coatings will give performance and logistics advantages to armament hardware. Utilization of this process can replace several armament components which currently specify hazardous cadmium plating. Considerable cost reductions can be made by reducing maintenance and rework costs on items now specifying organic post-treatments.

IMPLEMENTATION

A batch process was used and was controlled over a two-month period. The manganese phosphate coating process established in this effort is recommended for production trials at an Arsenal or Army Depot plant. The Military Specification will be modified to include the improved manganese phosphate coating process. An engineering change proposal will be initiated on the M42 grenade body coating requirement to include the phosphate coating.

MORE INFORMATION

To obtain more information contact the project officer, Mr. W. T. Ebihara, ARRADCOM, AV 880-6553 or Commercial (201) 328-6553.

Summary Report was prepared by Robert Hellem, Manufacturing Technology Division, US Army Industrial Base Engineering Activity, Rock Island, IL 61299.

MANUFACTURING METHODS AND TECHNOLOGY
PROJECT SUMMARY REPORT
(RCS DRCMT-302)

Manufacturing Methods and Technology Project 677 7722 titled, "Rotary Forging of 8" M201," was completed by Watervliet Arsenal in January 1980 at a cost of \$298,000.

BACKGROUND

One of the purposes of forging is to refine the as-cast microstructure, thereby improving the mechanical properties. It had previously been established that in conventional open die forging, a reduction in cross-sectional area of 3:1 was necessary to meet mechanical property requirements. On the basis of this rule, it was theoretically not possible to produce the 8" XM201 on the rotary forge machine. The physical restriction in tolerable preform size would allow only a 1.3:1 reduction on the breech end of the forging.

Data from a prior MMT program (Project No. 672 6943, "Engineering Study and Application of Metallurgical Processes to Manufacture of Cannon - Compression Forming) had shown that acceptable properties may be possible with reductions of less than 3:1 on electroslag remelted (ESR) material, due to greater cleanliness and more acceptable microstructure than that contained in air melted and air poured ingots. Use of ESR material, therefore, appeared to require less forging to achieve the desired structure and properties.

SUMMARY

The major objective of this project was to establish the capability of producing the 8" M201 Cannon on the rotary forge line. This would reduce both cost and manufacturing lead time. This objective was achieved and certain other successes were experienced as a result of this effort:

First, a 20" diameter electroslag remelted trepanned ingot was forged with the low breech end reductions, and heat treated to the mechanical properties required. Second, it was demonstrated that the induction heating system and the rotary forge machine could process a full size 8" M201 work-piece; and the associated heating and forging parameters were developed. Third, by heat treating the ESR forging, many of the heat treating parameters were also finalized.

BENEFITS

This project extended the capability of the rotary forge Integrated Line to produce heavy cannon tube forgings. The 8" forgings are three to five times the weight of forgings which comprise the bulk of the Integrated Line's

products. They are significantly different due to their large weight, heavy wall, and limited reduction. This project will supplement the information from previous programs, allowing utilization of the maximum capability of the rotary forge machine and the integrated line as capacity becomes available.

IMPLEMENTATION

This project demonstrated the capability to Rotary Forge 8" M201 Cannon; however, there was no plan formulated for implementation of the project results at project completion. The GFM rotary forge at that time had production requirements for 105mm and 155mm cannon tubes which precluded scheduling the 8" M201's.

MORE INFORMATION

Additional information may be obtained by contacting Mr. R. Meinhart at Watervliet Arsenal, AV 974-5703 or Commercial (518) 266-5703.

Summary Report was prepared by K. Bezaury, Manufacturing Technology Division, US Army Industrial Base Engineering Activity, Rock Island, IL 61299.

MANUFACTURING METHODS AND TECHNOLOGY

PROJECT SUMMARY REPORT

(RCS DRCMT-302)

Manufacturing Methods and Technology Projects E77 3588 and E78 3588 titled, "SLUF AE Mine Neutralizer Launcher," were completed by the US Army Mobility Equipment Research and Development Command in July 1979 at costs of \$50,000 and \$109,000, respectively.

BACKGROUND

One of the Army's free flight rocket systems required launcher tubes with a 14-inch outside diameter (OD) and a 0.125-inch wall thickness. These tubes were being manufactured by rolling aluminum sheets to the proper diameter and welding the longitudinal seam. This costly method was used because industry did not have the capability to produce thin-walled, seamless tubes in the required dimensions and tolerances. The largest commercially drawn tube known at the time was being produced by the Aluminum Company of America (ALCOA) and it had a 12.5-inch OD with a 0.153-inch wall thickness.

SUMMARY

The objective of this work was to develop a method for producing large diameter, seamless, thin-walled tubes.

A contract was awarded to ALCOA, Lafayette, Indiana. The effort evolved into a three-phase task. Phase I was to determine if existing equipment could be modified to produce the desired large diameter, thin-walled tubing in the required tolerances. Some difficulties were encountered during Phase I, so that in Phase II, the tube drawing procedures were modified and one of the mechanical property requirements of the tubing was reduced. During Phase III, mechanical properties, packaging, and shipping requirements were established.

Alloys 6061 and 6063 were selected for evaluation. The starting stock which was produced by the bench-draw method had a 15.5-inch OD and a wall thickness of 0.250-inch. The dimensional objective of the final tube was an OD of 13.72-inches and a wall thickness of 0.125-inch. Also, tube straightness was to be within 0.060-inch over its 120-inch length or 0.01-inch in a 2-inch segment. The minimum burst strength was specified as 500 psi.

Alloy 6061 was drawn to final size in five reductions with an intermediate heat treatment prior to the fifth reduction. Alloy 6063 was drawn to final size in four reductions and without heat treatment. Six finished tubes, 12-feet long, were to be produced for each alloy.

During drawing, two major problems were encountered; one with each alloy. The anticipated distortion with 6061 when solution heated and cold water quenched was more severe than expected. Ovality increased, due to quenching, from 0.011-inch before heat treatment to 0.110 after quench. The drawing

after heat treatment did not remove the ovality. In addition to ovality, the tubes were "banana" shaped longitudinally. It was known that straightening the longitudinal condition would make the ovality worse. The 6063-T4 room temperature age hardening resulted in breakage of three pieces. Attempts to salvage by cutting and repointing were unsuccessful. It was concluded that neither the 6061-T6 nor the 6063-T832 were viable alloy-temper combinations.

Cold drawing without heat treatment or artificial aging was considered for producing tubes of strain-hardened temper. However, the burst pressures calculated for strain-hardened tubes fell in the 400-500 psi range, somewhat short of the 500 psi minimum that was required. The minimum burst pressure was reduced to 200 psi and seamless tubes were drawn using alloys 6061-H1E66 and 6063-H1E66. The use of this new special temper resulted in dimensionally stable tubes. The development of the H1E66 temper solved the concern of adequate burst strength. The theoretical and actual burst data showed values approximately ten times those encountered during test firings of the candidate rocket system. Cutting of the thin-walled tubes without distorting the ends was not possible. The best commercial method proved to be cutting with a circular saw with the tube clamped between contoured holders. The ovality tolerance of plus 0.040 and minus 0.000-inch was difficult to obtain. Ovality measurements taken before and after cutting indicated that the cut tube will vary from both clamp pressure and springback. All three types of packing methods evaluated provided adequate protection from surface damage but none prevented ovality change during shipment. The randomness of the change indicated orientation of tubes in the package could be as important as the construction of the package, relative to dimensional stability.

BENEFITS

The cold-work technique developed will provide a seamless tube without the added cost of heat treatment. Prior fabrication processes required heat treating to obtain the 400-500 psi burst pressure. The new temper developed will be a source of cost savings to both government and commercial users of this new temper aluminum.

IMPLEMENTATION

Implementation of the extrusion method will not occur because the user found that the extruded tubes did not meet straightness and eccentricity specifications.

MORE INFORMATION

Additional information may be obtained by contacting William Millman, MERADCOM, AV 354-5470 or Commercial (703) 664-5470.

Summary Report was prepared by Andrew Kource, Jr., Manufacturing Technology Division, US Army Industrial Base Engineering Activity, Rock Island, IL 61299.

MANUFACTURING METHODS AND TECHNOLOGY
PROJECT SUMMARY REPORT
(RCS DRCMT-302)

Manufacturing Methods and Technology Project R78 3121 titled, "Application and NDT of Line Pipe for Motor Components," was completed by the US Army Missile Command in August 1981 at a cost of \$300,000.

BACKGROUND

The use of a standard pipe or tube mill product of appropriate size and sufficiently high yield strength offers a promising method for fabricating low-cost rocket-motor cases. A previous research program demonstrated that several low-alloy, low-cost steels used in commercial gas or oil transmission pipe could be heat treated to the necessary high-strength level that would be required for the thin-wall motor case. The objective of the program was to investigate and establish a procedure for manufacturing low-cost, rocket-motor cases utilizing commercial pipe or tube mill products.

SUMMARY

The initial portion of the program (Phase I) involved the study and selection of the most promising concepts for fabricating the motor cases from standard pipe or tube mill products. One of the principal goals in Phase I was to utilize existing commercial processes to manufacture the motor cases. The results obtained from the initial portion of the program are reported in Technical Report T-CR-79-28 by Battelle Columbus Laboratories.

Based on results of the first phase of the program, the selected concepts were applied to fabricate a series of cases for delivery to the US Army Missile Command in the final stage of the program. The following were the important results of the final stage of the program.

The motor case design was modified with respect to the original design. The principal modification was a change from the traditional throated-nozzle configuration in the motor case shell to a straight shallow angled taper in the nozzle section. The modified experimental motor case design is shown in Figure 1. This would allow the nozzle insert to be prepared independent of the case and simply inserted between the nozzle section and head-end closure forming operations. Also, the target case diameter was increased from 203 to 230 mm (8.00-9.055 inches). The final diameter actually obtained was 8.802 inches (224 mm) which resulted from the size of tubing that could be procured for this study.

During the manufacture of the prototype motor case shells, it was demonstrated that:

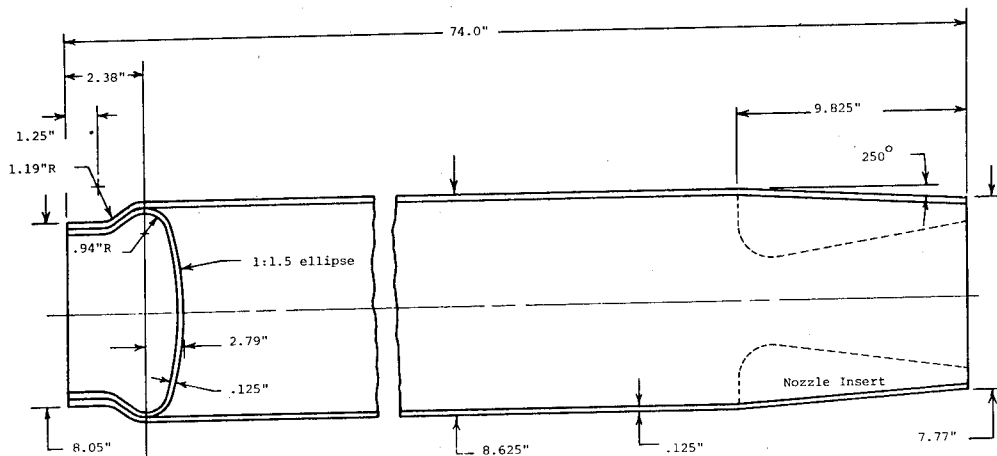

Figure 1 - Modified Experimental Motor Case Target Design

(1) High-quality ERW AISI 1035 steel tubing to meet the case requirements can be manufactured on a standard tube mill facility.

(2) The desired uniform mechanical properties can be achieved in the case tube by heat treating.

(3) The explosive sizing process both proof tests the case tubes for weld integrity, and produces diameter, ovality, and straightness dimensions within the required "relaxed tolerances".

(4) The shrink forming process forms both the case nozzle and head-end closures with the desired configuration and accuracy.

In hydrostatic burst testing, a full-scale case manufactured by the selected procedure burst at 3750 psi (25.9 MPa) which is slightly over two times the design chamber pressure during motor firing. Of equal importance, was the fact that the failure was in the case body and its initiation was not associated with the tube weld, nozzle, or head-end closure.

A total of 20 full-scale prototype cases and 10 heat treated and explosive impact proof tested case tubes were delivered to US Army Missile Command at the conclusion of the program. A finished motor case is shown in Figure 2.

BENEFITS

An analysis of cost, based on the manufacturing procedure developed in this program, projects an estimated production cost of \$223.93 per case. This represents an estimated \$80.00 per case cost reduction for the new MLRS.



Figure 2 - Finished Full Scale Motor Case

IMPLEMENTATION

This alternative technology is being considered by Vought for implementation on the high production volume MLRS. Other systems under consideration include the ROLAND, IMPROVED HAWK, and SAM-D rockets.

MORE INFORMATION

Additional information may be obtained by contacting Mr. William Crownover, US Army Missile Command, AV 746-5821 or Commercial (205) 876-5821. The following technical report contains details of this program: "Fabrication and Delivery of Rock Motor Components Utilizing Pipe Mill Products," TR RK-CR-81-4, Battelle Columbus Laboratories, August 1980.

Summary Report was prepared by Ron Russell, Manufacturing Technology Division, US Army Industrial Base Engineering Activity, Rock Island, IL 61299.

MUNITIONS

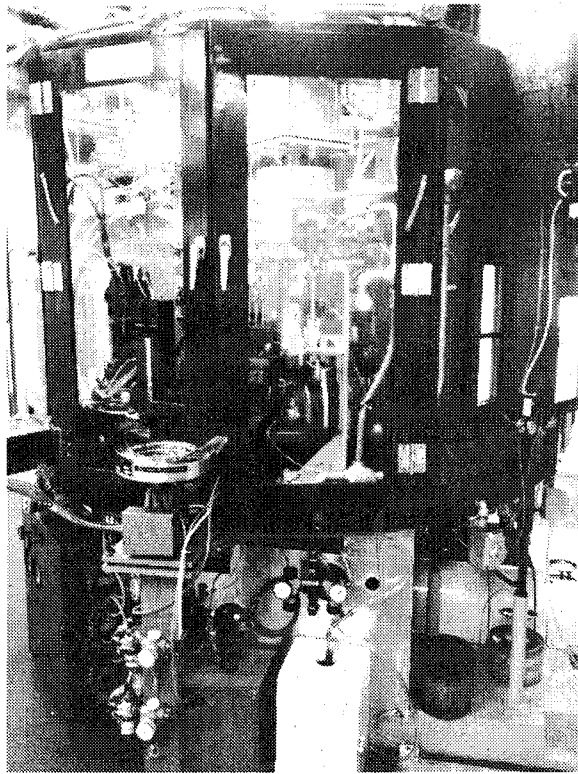

IOWA AAP DETONATOR LOADER

MANUFACTURING METHODS AND TECHNOLOGY

PROJECT SUMMARY REPORT

(RCS DRCMT-302)

Manufacturing Methods and Technology projects 571 6494, 573 6494, and 574 6494 titled "New Concepts for Manufacture and Inspection of Cal .50, 20mm and 30mm Ammunition" were completed on 12/31/74, 9/30/76 and 9/30/76 at costs of \$1,000,000, \$1,293,000 and \$1,652,000 respectively.

BACKGROUND

These projects were initiated to replace the existing, outdated manufacturing equipment for producing Cal .50, 20mm and 30mm ammunition with modern automated manufacture and inspection equipment. The production rates were to be increased from an average of 85 ppm to a 400 to 600 ppm range while simultaneously reducing the direct labor and floor space requirements by 90 percent. Midway through the program the plans for a highly automated facility were dropped and the equipment design was modified to operate as an independent facility to automatically assemble fuzes to projectiles for 20mm ammunition. Follow-on projects have been funded to complete this effort.

SUMMARY

The object of this fuze-to-projectile development program is to provide a system to assemble high explosive charged projectiles with point detonating fuzes. In-process inspections are provided to assure quality of the final assembly. The equipment and its operation is as follows:

Infeed Equipment

The charged projectile bodies are placed nose up into open metal boxes that are divided into 100 cells. The metal boxes are placed in a compartmented storage-transit dolly that can carry 80 boxes (800 rounds). The operator removes one of these boxes, places it on the service table and slides it into the transfer box assembly. Guides are provided to aid this operation. The operator then rotates the assembly to latch it to the turnover mechanism. The 100 projectiles are then dumped bottom up into matching cells in the transfer assembly and the machine resets itself for the next box of projectiles. At full production rate this operation is performed four times per minute.

Transfer Equipment

The projectile bodies are fed to the assembly machine by means of a screw type conveyor from an island style feeder. The transfer wheel of the island feeder is driven by one of the conveyor screws to assure synchronization.

Controls and Instrumentation

The machine has 30 projectile assembly stations. Each of the stations can be operated in one of 3 modes, i.e. Normal, Refeed and Sample. The usual position is "Normal" which is used to assemble the product. If a tool station is missing or is suspected of being faulty, then the switch can be moved to the "Refeed" position and the fuzes and projectiles, destined for that station, are removed from the system. This feature allows the machine to operate with one or more of the stations missing or inoperative. The remaining position is "Sample", which is used to check the output of a given station if improper operation is suspected. The output from the selected station is automatically diverted to a sampling location.

Figure 1 is a schematic of the assembly machine indicating the operations. Additional controls and monitors are provided to assure proper system operation and collect production statistics.

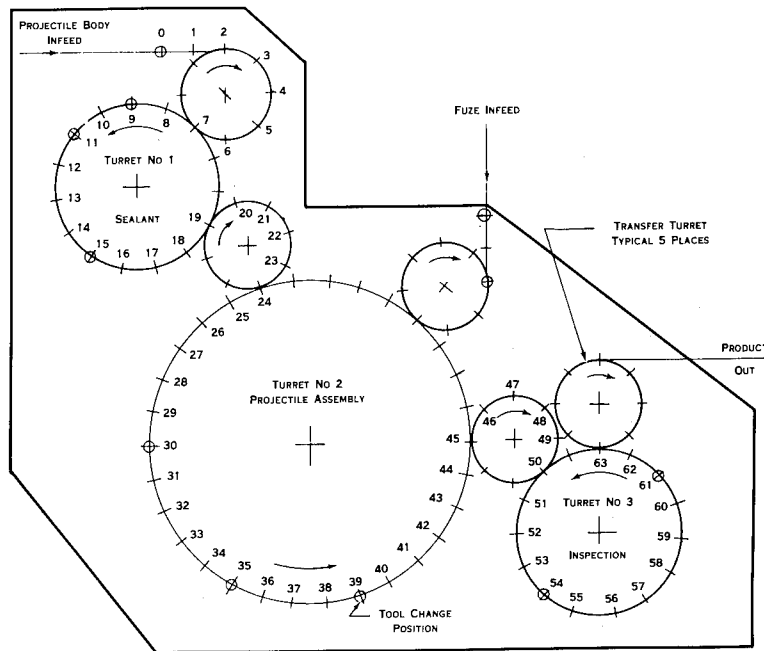

Figure 1 - Fuze to Proj Assembly Machine

BENEFITS

These projects substantially developed an automated system for assembling the M505 fuze to five models of 20mm projectiles. The work was terminated before all of the subsystems had been assembled and integrated with the machine. Preliminary operational data indicates that a 600 ppm production rate could be achieved if future production schedules would warrant completing these efforts.

IMPLEMENTATION

There are currently no plans to complete the assembly and installation of this machine due to the low production rates for 20mm ammunition. If the production rates increase it may become economical to complete this effort.

MORE INFORMATION

Additional information is available in a final report titled, "Development of Semiautomated Equipment For Assembly of Fuzes to 20mm Projectiles", AD-E400622 Contract No. DAAK10-78-C-0326 or from the ARRADCOM project officer, Mr. William Dittrich, AV 880-2693 or Commercial (201) 328-2693.

Summary report was prepared by Hal Weidner, Manufacturing Technology Division, US Army Industrial Base Engineering Activity, Rock Island, IL 61299

MANUFACTURING METHODS AND TECHNOLOGY
 PROJECT SUMMARY REPORT
 (RCS DRCMT-302)

Manufacturing Methods and Technology projects 574 4099 and 575 4099 titled, "Hazard Analysis and Classification of Pyrotechnic Compositions and Operations" were completed by the US Army Armament Research and Development Command in July 1979 at costs of \$986,000 and \$605,000, respectively.

BACKGROUND

There are obvious hazards involved in the manufacture, transportation and storage of pyrotechnic munitions. The test procedures contained in Army Technical Bulletin TB700-2, "Explosive Hazard Classification Procedures" were found to inadequately cover all pyrotechnic materials and operations. After this was discovered, hazard classification testing according to TB700-2 was suspended except for some production items.

SUMMARY

This project was a joint effort involving Picatinny Arsenal (PA) and Edgewood Arsenal (EA). The materials and procedures of interest to PA and EA cover the complete spectrum of pyrotechnics. The goal was to develop sensitivity tests, classification procedures, criteria and hazard analysis applicable to all pyrotechnic materials and operations. Other objectives included: (a) establishing safety standards, (b) developing reliable data for quantity distance tables, and (c) generating cost savings by reductions in hazard classification for pyrotechnics which had been misclassified, where appropriate.

Pyrotechnic materials were broken down into five classes and a typical composition was selected for each class. These classes and compositions are given in Table 1.

<u>Composition</u>	<u>Formulation</u>
Igniter (SI-193)	Boron - 25%
	KNO ₃ - 75%
	VAAR - 1% (added)
Photoflash Powder (PFP-555)	Al - 40%
	BaNO ₃ - 30%
	KClO ₄ - 30%
Illumination Composition (FY-1451)	Mg - 46%
	NaNO ₃ - 45%
	Laminac - 9%

<u>Composition</u>	<u>Formulation</u>
Decoy Composition (FY-306)	Mg - 54% Teflon - 46% Nitrocellulose - 2.6% (added)
Delay Composition (DP-973)	Boron - 10% BaCrO ₄ - 90% VAAR - 1% (added)

Table 1 - Five Classes of Pyrotechnic Materials and Typical Composition

Separate teams were formed to address each class of material under various processing conditions. Their results were then brought together in the following technical reports.

Propagation Rates in Thermally Ignited Pyrotechnic Compositions, August 1978, ARLCD-TR-77049.

Hazard Analysis of Pyrotechnic Compositions Output from Initiation Within a Simulated Processing Bay, July 1975, TSD TSIF 75-2.

Propagation and/or Detonation Tests of Pyrotechnic Compositions, July 1974, Tech Memo 2146.

Friction Sensitivity Testing of Pyrotechnic Ignition Compositions, June 1976, Tech Memo 2212.

Engineering Assessment of the Hazard Potential from Accidental Initiation of Pyrotechnic Compositions in Typical Processing Equipment, August 1975, IITRI Project J6345.

Methods for Monitoring Initiating Sources Generated in Pyrotechnic Processing Equipment, September 1976, Tech Report 4981.

Pyrotechnics Hazards Evaluation and Classification Program - Results of TB700-2 Propagation and Output Tests for Packaged Pyrotechnic Munitions, June 1974, EA-FR-4902.

BENEFITS

The benefits of this project are new and improved test methods for determining the hazard classification of loose and packaged pyrotechnic compositions. A better knowledge was gained as to their accidental initiation or discharge during manufacturing, handling, storage and transportation. Safety should be enhanced and knowledge was gained on the preferred design for new facilities involved with these materials.

IMPLEMENTATION

DARCOM, ARRCOM, and all Army and Navy pyrotechnic processors have been advised of the findings of this program. Safety engineers and officers were provided all necessary findings of this program to make appropriate revisions of TB 700-2. When revised, this bulletin will be useful and meaningful for assessing the hazard classification of both loose and packaged pyrotechnics.

MORE INFORMATION

Additional information on these projects may be obtained from Dr. F. R. Taylor, AV 880-6363 or Commercial (201) 328-6363. He should be contacted also for copies of the above listed Technical Reports.

Summary Report was prepared by Wayne Hierseman, Manufacturing Technology Division, US Army Industrial Base Engineering Activity, Rock Island, IL 61299.

MANUFACTURING METHODS AND TECHNOLOGY
PROJECT SUMMARY REPORT
(RCS DRCMT-302)

Manufacturing Methods and Technology Projects 577 1320 and 578 1320 titled, "Pilot Stations for Filling and Closing Improved WP Munitions" were completed by the US Army Armament Research and Development Command in December 1980. The project costs were \$374,000 and \$375,000, respectively, for each of the funded years.

BACKGROUND

In 1975, the Army authorized the development of a family of improved white phosphorus (WP) smoke munitions under high-priority programs. The new munitions were to provide obscuration of a target for a specified time. One of the rounds developed by US Army Armament Research and Development Command (ARRADCOM), with configuration control by Project Manager 2.75-Inch Rockets Systems, was the M259 2.75-inch WP warhead with the Mark (Mk) 40 rocket motor. This item was type classified Standard A in July 1978 after a 3-year development program. Concurrent with the hardware program was a series of engineering projects to develop the process technology and equipment for filling and closing the new WP canister. These projects used the existing WP filling line at Pine Bluff Arsenal (PBA) which was established in 1976. The design of special equipment for loading, assembling, and packing the complete rocket was also necessary.

SUMMARY

The objective of this project was to proveout, with production type equipment, the filling and closing techniques for a new white phosphorus filled smoke rocket. The equipment provided by this project was then used to establish an initial production capability for the munition. In addition, a low-rate loading, assembling, and packing capability was established for the complete rocket.

The approach for filling and closing was to utilize the techniques and equipment developed in earlier MMT projects. A volumetric dry fill system established in Project 576 1319, "Process Design for Impregnating Wicks With White Phosphorus" was used to introduce WP directly into the munition through a nozzle. Figure 1 shows a diagram of the volumetric filling system. The dry fill system was enclosed in a cabinet with entry and exit tunnels. The cabinet atmosphere was supplied by an inert gas generator (N_2+CO_2) located in a separate building. Both the volumetric filling cylinders and the filling nozzles had to be modified for the M259 canister. The filling cycle began when an empty munition moved into position under the filling nozzle. The filling nozzle was inserted into the munition, the filling valve opened for a timed interval, dispensing a fixed volume from the volumetric cylinder into the munition.

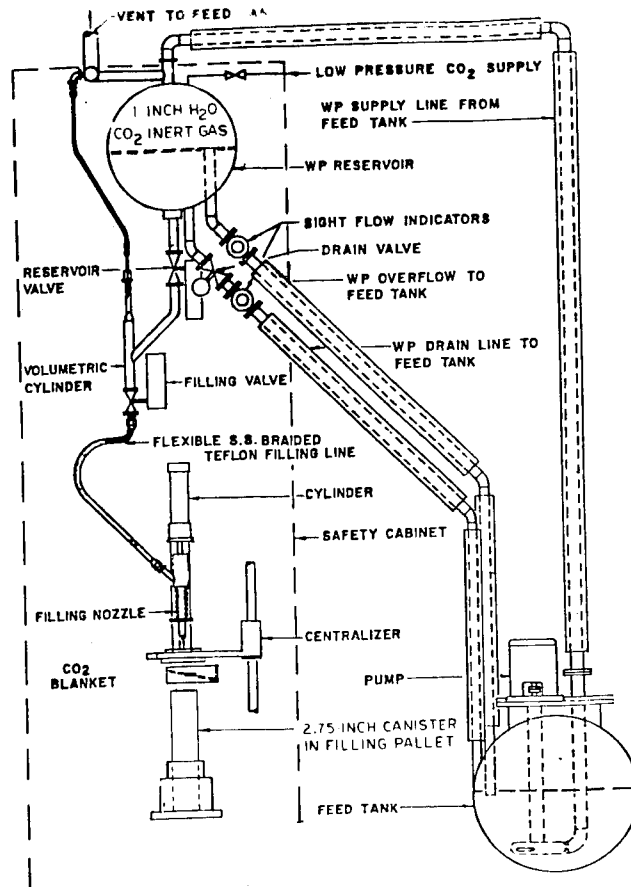

Figure 1 - WP Volumetric Filling System

For closing the munition, inertia welding was used instead of a former press fitting operation. The parameters for performing this weld in production were developed under MMT Project 576 1336. Inertia welding was chosen since it was very fast and reliable. The inertia welder was purchased and consisted of a flywheel group, tailstock fixturing, hydraulic system, spindle chuck, tooling, automatic feed system, and programmable control equipment. The machine was capable of welding the canister plug to the filling part of the canister body while the canister was in the filling port up position.

During the loading, assembling, and packing of the development round by Chemical Systems Laboratory, it was learned that no new techniques or equipment would be required for production. Consequently, work on the loading, assembling, and packing line was assigned to Pine Bluff Arsenal (PBA). The loading, assembling, and packing of the development round was essentially a manual operation carried out by a crew of 26 personnel which included line operators, forklift operators, foreman, quality control inspectors, and maintenance personnel. Standard equipment was used which included three powered conveyors, and one gravity roller conveyor. Numerous assembly jigs and fixtures and tables were dispersed along the line. At the end of the line was the standard strapping equipment for wooden boxes and pallets.

Under this project, three pieces of semi-automatic equipment were designed and procured by PBA for use on this loading, assembling, and packing line. This equipment included a drill and pin machine to secure the plastic

nose cone to the warhead casing with aluminum pins. Following the warhead assembly, a torquing machine was used to engage the warhead and rocket motor threads and torque the assembly to a prescribed load. After assembling the rocket, it was manually slipped into a fiber shipping tube. A tape and stencil machine was procured to tape and mark the fiber container according to the proper specifications.

After the equipment was installed, the filling and closing line and the loading, assembling and packing facility were tested. Initially, problems were encountered with the inertia welder and drill-pin machines. These problems were corrected by various modifications to the machines. Final acceptance testing was completed in October 1980 with 150 rounds. The results indicated that the M259 WP warhead could be filled and closed at a rate of 800 rounds per 8-hour shift. The warhead could be loaded, assembled, and packed on the new line at a nominal rate of 700 rounds per 8 hour shift with the drill/pin machine as the controlling station.

BENEFITS

The filling, closing, loading, assembling, and packing capabilities were established for initial production of the M259 2.75 inch WP Rocket munition.

IMPLEMENTATION

The existing WP dry fill line at PBA was modified and equipment procured and installed for the LAP line for production of the M259 rocket. Approximately, 30,000 rockets have been produced successfully at the PBA facility.

MORE INFORMATION

To obtain additional information, contact the project officer, Mr. M. Erickson, AUTOVON 584-2390 or Commercial (301) 671-2390.

Summary report was prepared by Pete Martin, Manufacturing Technology Division, US Army Industrial Base Engineering Activity, Rock Island, IL 61299.

MANUFACTURING METHODS AND TECHNOLOGY
PROJECT SUMMARY REPORT
(RCS DRCMT-302)

Manufacturing Methods and Technology Project 578 4252 titled, "Improve Present Processes for the Manufacture of RDX and HMX," was completed by the US Army Armament Research and Development Command in July 1980 at a cost of \$281,000.

BACKGROUND

This project was a continuation of process studies to improve the present methods for manufacturing RDX and HMX compositions. The FY77 efforts under this project, investigated the use of reaction promoters to improve the yield and efficiency of the RDX/HMX process. Paraformaldehyde and hexamine were found to increase HMX yields. In addition, a dual pre-coat process was developed for Composition C4.

In the current modified Bachman Process, the HMX produced is simmered in spent acid to effect purification by destruction of linear nitramine by-products and to increase the particle size. Since the simmer step required significant energy for heating of large quantities for extended times (four hours), it offered an opportunity for both energy savings and a reduction in simmer time. Efforts were needed to characterize and evaluate possible improvements in the simmer process.

SUMMARY

The primary objective of this effort was to examine the present HMX simmer process and determine process improvements which could be accomplished. An additional objective was to evaluate the reaction promoters identified in previous year's work in the pilot plant at ARRADCOM.

The current HMX process operations, from the combining of reactants through the end of the simmer process is shown in Figure 1.

The chemicals 501 (Hexamine), 521 (acetic acid), 509 (acetic anhydride), 503 (nitric acid), and 504 (ammonium nitrate) are added to the nitrator heel and the reaction takes place isothermally at $44^{\circ} \pm 1^{\circ}\text{C}$. The reaction slurry is discharged to an aging tank and held 40 minutes to complete the reaction. The aged, anhydrous slurry is diluted with water or dilute acetic acid to hydrolyze excess acetic anhydride and to reduce the spent acid to $80 \pm 2\%$ acid. Simmering is effected by heating the aqueous spent acid at 100°C (373°K) for four hours. The treatment hydrolyzes by-products from the reaction, accomplishes particle growth to facilitate subsequent product recovery operations, and permits HMX purification by extracting by-product RDX during subsequent solids-liquid separation.

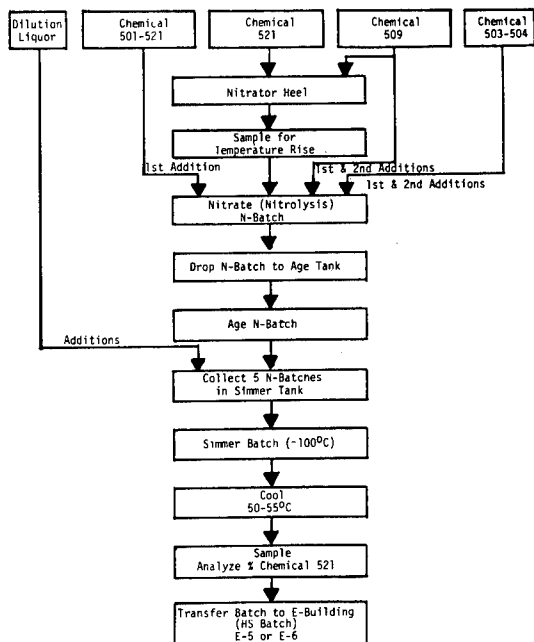

Figure 1 - Process Flow Sheet for Production of HMX

The approach in this project included the following tasks: Characterize the present HMX simmer system with respect to particle growth and destruction of by-product nitramines; establish residence time for the simmer purification at various temperatures and acetic acid concentration; determine the effect of time, temperature, and acid concentration on particle growth.

Bench scale studies were conducted on the HMX simmer process and various analytical techniques were used to identify products, by-products, acid concentrations, gaseous products, thermal properties, and particle size distribution. Process parameters studied were time, temperature, nitric acid concentration, and acetic acid concentration. They were considered both separately and in combination. Based on the results, a modified simmer process was defined. These modified process conditions were: (1) acetic acid concentration, $88\% \pm 2\%$, (2) nitric acid concentration, $0.5\% \pm .25\%$, (3) temperature, $106^\circ \pm 2^\circ\text{C}$, and (4) total simmer time, 150 minutes. Experiments were conducted to compare the modified simmer process to the standard process.

Results of the process studies indicated that the modified process improved the overall purification of the simmer liquid medium by more rapid destruction of the contaminants. The standard simmer time could be reduced to 120 minutes in the present system with no modifications other than time. Product solids purity and the residual by-product levels in spent acids were equivalent to the present system. The standard simmer time could be reduced further by modification of process parameters so that simmer purification equivalent to the present system could be achieved within 90 minutes. With optimum nitric acid levels (0.5%) and/or elevation of temperatures to 106°C (379°K), this could be achieved at acetic acid levels between 80% and 90%. The by-product destruction rates varied directly with simmer temperature, inversely with acetic acid concentration, and were maximum within a rather narrow optimum range of nitric acid concentration ($0.5 \pm 0.25\%$).

The range of process variables explored had little effect upon particle size. Filtration time was not solely dependent upon particle size. It was, to a large extent, dependent on the composition of the simmered slurry. Simmering for the purpose of achieving improved filtration rates through particle growth was not necessary.

Pilot process work was conducted in the ARRADCOM pilot plant to improve the yield of the HMX batch process. Reaction promoters as well as variation of temperatures of various steps of the reaction were investigated using a batch size of five pounds. The reaction promoters studied were hexamethylenetetramine (hexamine) and paraformaldehyde. Runs with paraformaldehyde in the heel were difficult to filter, consequently work was concentrated on the addition of hexamine to the heel. The addition of 12% extra hexamine in the reaction heel prior to beginning the nitrolysis reaction was found to increase the throughput of product by 16.4%.

BENEFITS

This project demonstrated that the simmer time for the production of HMX can be reduced without affecting the final product and result in cost savings. In addition, pilot plant studies indicated that the addition of the reaction promoter, hexamine resulted in increased HMX yields.

IMPLEMENTATION

The reduction of the HMX simmer time from 240 minutes to 120 minutes has been applied to plant production at Holston AAP. The use of the reaction promoter, hexamine to the heel, is currently being evaluated in production at Holston AAP prior to full implementation.

MORE INFORMATION

To obtain additional information, contact the project officer, Mr. R. Goldstein, AV 880-4123 or Commercial (201) 328-4123.

Summary Report was prepared by Peter Martin, Manufacturing Technology Division, US Army Industrial Base Engineering Activity, Rock Island, IL 61299.

MANUFACTURING METHODS AND TECHNOLOGY
PROJECT SUMMARY REPORT
(RCS DRCMT-302)

Manufacturing Methods and Technology Project 578 4285 titled, "TNT Equivalency Testing in Support of Safety Engineering for Ammunition Plants," was completed by the US Army Armament Research and Development Command in June 1980 at a cost of \$391,100.

BACKGROUND

The US Army has been involved in a continuing program to upgrade the safety standards of new and existing ammunition plants. In support of this program, design standards are developed for hardening protective structures to withstand the effects of the detonation of high explosives. Design and safety engineers require data pertinent to the maximum strength of a blast wave that may originate from any of the explosive or deflagratable materials present in a plant. Since blast parameters were not available from the literature on certain explosives and propellants, efforts were needed to establish TNT equivalencies of these materials. By utilizing this data, significant cost savings could be achieved by avoiding over-design of structures and safety of personnel improved by the installation of adequate blast protection.

SUMMARY

The purpose of this project was to generate peak pressure and positive impulse data from blast measurements of a variety of high energy materials (explosives and propellants). These results were compared to the blast output of surface bursts of hemispherical TNT in order to determine the TNT equivalency of the material.

Tests were conducted on bulk nitrocellulose, Composition C-4, LX-14 bulk and pressed billets, Composition A-3 and Ball Powder WC844. These tests resulted in the establishment of pressure and impulse curves from the materials detonated. From these curves, TNT equivalencies were calculated and a technical report prepared. The following paragraphs summarize the results on some of the materials tested:

Bulk Nitrocellulose

Nitrocellulose was detonated in configurations representative of in-plant scaled storage cans, scaled weigh feeder tub and a simulated section of the Thermal Dehydration Unit as shown in Figure 1. A composition C-4 conically shaped booster charge was centered on the top of each test item. Each configuration was placed on a AISI 1010 carbon steel witness plate. Transducers were mounted to provide measurements of the blast pressures. The TNT

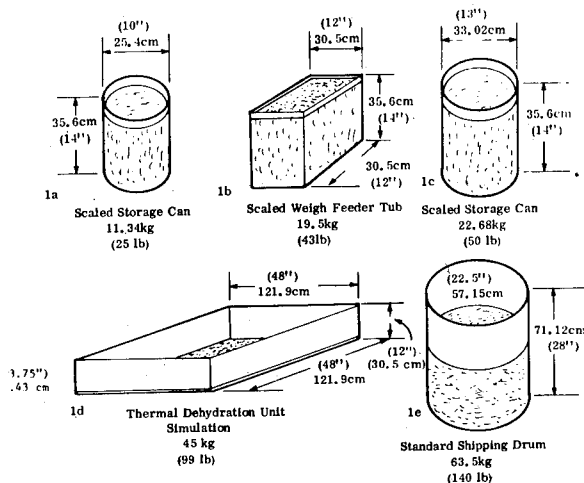

Figure 1 - Test Container Configurations

pressure equivalency values of nitrocellulose for the can, tub, and drum containers were greater than 100% for the near field scaled distances and less than 100% for the far field scaled distances. The impulse values versus scaled distance were generally less than 100% at all measured distances. This was true for charge weights of 11.34, 19.5, 22.68 and 63.5 kg. The TNT equivalency values of nitrocellulose at 45 kg charge weights under simulated conditions found in the Thermal Dehydration Unit were generally less than 100% for pressure and scaled impulse. The exceptions were at the near field value of 1.25 m/kg $1/3$ where the pressure equivalency was 130%, and the far field value of 7.52 m/kg $1/3$ where the impulse equivalency was 105%.

LX-14 High Explosive

High explosive mixture LX-14 was detonated in configurations representative of in-plant scaled tote bins and aluminum transfer carts in both bulk and pressed billets. Blast parameters were measured and TNT equivalency was computed based on comparison with TNT hemispherical surface burst. To within an experimental error, the pressures were generally greater than 100% at all scaled distances with exceptions noted. Impulse values varied depending upon geometry and at same scaled distances were less than 100% but overall, with exceptions noted. Test results indicate that to within experimental error, scaling according to the cube root of the charge weight occurred but geometry had an effect on measured values.

Ball Powder WC844

Ball powder (double base propellant) was detonated in configurations representative of two types of shipping containers and simulated in-plant process dryer beds. Blast output parameters were measured and TNT equivalency values were computed based on comparison with TNT hemispherical surface bursts. The peak positive overpressure TNT equivalency values of ball powder in the two types of shipping containers were found to be greater than 100% at all scaled distances tested when compared to the standard TNT hemispherical

reference. The TNT equivalency values to ball powder in the dryer bed configuration were dependent upon geometry since there were significant differences in results between the long and short sides of the dryer bed. The pressure equivalencies and impulse values were generally greater than 100% for near and far field scaled distances on the long side of the dryer bed. For the short side, the pressure and impulse data were generally less than 100% at near field distances and greater than 100% at far field distances.

BENEFITS

This project provided TNT equivalency data which, when used with AMCR 385-100 and TM5-1300, enables the designer to design walls that will safely resist the blast effects of an accidental explosion of the materials tested. Considerable cost savings can be realized through the use of the data developed.

IMPLEMENTATION

The results published in technical reports were distributed to AAP's, Corps of Engineers, other design agencies, and various other safety echelons for use in conjunction with TM5-1300. The equivalency results using TNT as a basis can be converted readily to overpressures and impulses since the design data in the manual is based upon TNT curves. This enables the designer to calculate loads on protective walls readily for the energetic material in question.

MORE INFORMATION

To obtain additional information, contact the project officer, Mr. J. Marsicovete, AV 880-3906 or Commercial (201) 328-3906.

Summary Report was prepared by Pete Martin, Manufacturing Technology Division, US Army Industrial Base Engineering Activity, Rock Island, IL 61299.

MANUFACTURING METHODS AND TECHNOLOGY
PROJECT SUMMARY REPORT
(RCS DRCMT-302)

Manufacturing Methods and Technology Project 578 4508 titled, "Process Improvement of Pressable RDX Compositions," was completed by the US Army Armament Research and Development Command in September 1980 at a cost of \$300,000.

BACKGROUND

The present production processes for pressable RDX compositions of A3, A4, and A5 at Holston AAP utilize similar facilities which produce Composition B. The types of facilities are recrystallization, filtration, drying, and packaging. These same facilities may be required for Composition B during mobilization and restrict the production capacity for all compositions. This limited production level is inadequate for meeting the current mobilization requirements.

Work was initiated to improve and modernize the present processes for the manufacture of pressable RDX compositions to meet the mobilization levels.

SUMMARY

The overall objective of this effort was to provide Holston AAP with the capability to produce the A Compositions at rates sufficient to achieve mobilization requirements. This effort was to develop improved, modernized manufacturing methods and facilities for producing the pressable RDX compositions. This development program included literature, laboratory and pilot plant investigations designed to modernize the preparation, de-watering, drying, and packaging operations.

In the area of preparation of A Compositions, two alternative coating processes were identified and investigated. Several methods were evaluated under the two main processes, dry coating and wet slurry coating. Under dry coating the methods studied were the Wurster Air-Suspension Process, drum coating, fluidized bed, direct incorporation, spherical coating pan, Gemco Formulator, fluid energy, and smear coating. The dry coating studies did not yield a suitable method for producing the A Compositions. The major problem with the dry coating process was the addition of the wax. The uneven wax coating resulted in a product which did not meet the specification requirement. In addition, some of the methods were considered too hazardous for normal in-plant operation.

For the wet slurry coating process, the methods investigated included the static mixer/in-line cooler, emulsification wax coating, and the solvent/wax addition coating. Compositions A3 and A4 were successfully produced by

utilizing the solvent/wax method. In that method, a n-octane/wax solution was added to a RDX water slurry and the n-octane removed later by distillation. The product produced met all specifications and was superior to current production material in product coating quality and impact sensitivity. Composition A5 was successfully produced by adding a cyclohexanone/stearic acid solution to an RDX/water slurry followed by removal of the cyclohexanone by distillation. The product met all specifications and was a better product than that currently produced. In addition, a shorter batch cycle in the new process provided a product cost savings.

Prior to determining the means of filtering/dewatering the A compositions, filtration leaf tests were performed. These tests provided a means of determining product filterability and filter media efficiency. Results of these tests indicated that the A compositions could be dewatered rapidly by the use of a traveling belt filter, such as an Eimco Extractor or a Bird Pannevis Filter.

For the drying operation, studies involved the evaluation of a Wolverine Jetzone Dryer which was available from previous investigations on drying A7 compositions and a review of current dryer technology. The Jetzone Dryer evaluation indicated that it was unacceptable for use in drying the A compositions. Composition A3 was not dried to the 0.1 weight percent moisture within a reasonable time. Compositions A4 and A5 were dried to the 0.1 weight percent moisture but the drying operation generated excessive dusting. A dryer study was then conducted first, to establish the guidelines for selection of a dryer, listing the most desirable features, surveying the commercially available dryers, and then, finally selecting the most suitable for A compositions. As a result of the study, a continuous tray dryer manufactured by Wyssmont was selected.

The Wyssmont Turbo-Dryer is a continuous, vertical tray dryer consisting of a "stack" of rotating trays which revolve around a core of rotating turbo-fans. The trays transport the material through the dryer while the turbo-fans circulate heated air across the layers of solids on the trays. Figure 1 is a sketch of the internals of one of these units.

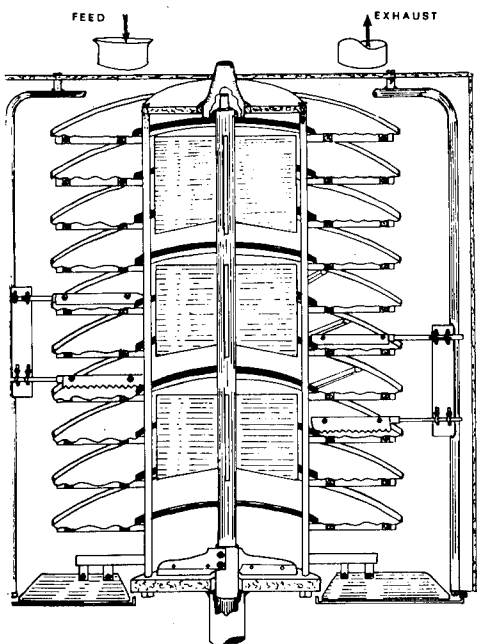

Figure 1 - Wyssmont Tray Dryer

Wet solids enter the top of the Wyssmont dryer through a charging nozzle which deposits the explosives in a "pile" on the first tray. This "pile" then passes under a stationary leveler bar which spreads the solids out on the tray section to form a layer. Heated air from the inlet air plenum is picked up by the turbo-fan, circulated at a relatively low velocity across the solids to remove the product moisture. At the end of one tray revolution, the solids are pushed through radial slots cut in the trays with the material falling to the next tray.

Solids continue to pass from tray to tray following the sequence described above until they are discharged from the bottom of the dryer. The drying air, which was introduced through pre-positioned dampers to a dryer "zone", passes upwards through the dryer and is discharged through an exhaust duct work to a scrubber.

As a result of the dryer effort, a pilot Wyssmont Turbo-Dryer was purchased and will be installed at Building L-3 at Holston AAP.

The packaging operation was not piloted since experience gained during operation of the Line 1 prototype indicated that this operation could be easily incorporated into an A-compositions production facility.

BENEFITS

Improved processes for the manufacture of Compositions A3, A4 and A5 were developed which will increase the capacity of the present equipment and lower the cost of producing these compositions.

IMPLEMENTATION

The wet slurry process utilizing the solvent/wax method to produce compositions A3 and A4 and the solvent/stearic acid method for Composition A5 has been implemented into production at Holston AAP. The drying operation using the Wyssmont Turbo-Dryer is planned to be implemented pending receipt and prove-out of the new dryer.

MORE INFORMATION

To obtain additional information, contact the project officer, Mr. J. Dowden, ARRADCOM, AV 880-3637 or Commercial (201) 328-3637.

Summary Report was prepared by Peter Martin, Manufacturing Technology Division, US Army Industrial Base Engineering Activity, Rock Island, IL 61299.

MANUFACTURING METHODS AND TECHNOLOGY
PROJECT SUMMARY REPORT
(RCS DRCMT-302)

Manufacturing Methods and Technology Project 579 4291 titled, "Blast Effects in the Munition Plant Environment," was completed by the US Army Armament Research and Development Command in September 1981 at a cost of \$235,000.

BACKGROUND

This effort was the continuation of the development of safety design criteria for application in the design and layout and/or modernization of Army ammunition plants. The FY77 effort under this project emphasized the development of safety design criteria for pre-engineered frame buildings and studies of the blast effects of openings in buildings. Cold formed steel panels have been widely used in the construction of steel structures and pre-engineered building at explosives plants and storage facilities. Some guidelines were available for designing steel panels for static loads, however, additional data was necessary for the design of steel panels to withstand an explosive blast. This project was initiated to provide the necessary data.

SUMMARY

This project developed data and criteria, not presently available for the response characteristics in a blast environment of cold-formed steel panels used in buildings. This information was used to expand the scope of the safety manual TM5-1300.

To obtain the criteria, a test program was performed at Dugway Proving Ground (DPG), Dugway, Utah. The objectives of the test program were to evaluate the blast capacities of cold formed steel panels having both closed and open hat-type cross sections and to evaluate the dynamic load capacities of various panel connection details.

The steel panels were manufactured in either open sections forming continuous corrugations or closed sections consisting of two flat sheets, one of which is formed into a series of hat sections. The formed and flat sheets of the closed panels were shop-welded together. A cross section of the types of steel panels tested is shown in Figure 1.

Two standard two-foot wide panels were fastened together by either seam welds or sheet metal screws to form a four-foot wide test panel. The test panels were mounted on four wooden box-like structures. The structures were then towed to the test site where they were subjected to blast overpressures ranging from 2.07 kPa (0.3 psi) to 103.4 kPa (15 psi). The blast loads were produced by detonating 900 kilograms (2,000 lbs) of propellant. The charges

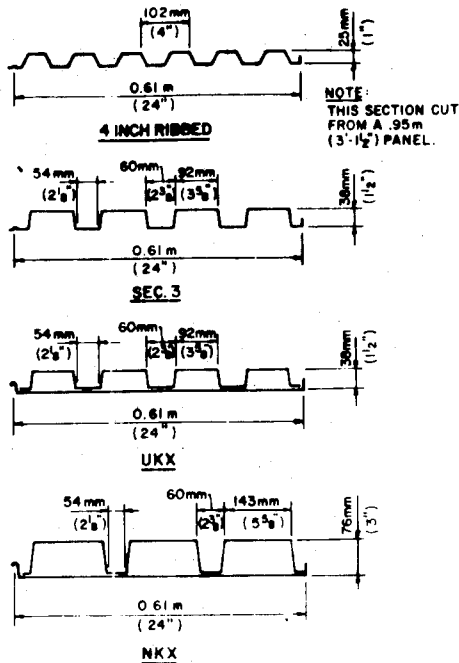

Figure 1 - Cross Sections of Cold-Formed Steel Panels

used in the test were M26E1 and T28E1 artillery type propellants as the primary charges, and Composition C4 as the booster charge. Specially mounted transducers measured blast overpressures and two high-speed motion picture cameras recorded any transient motion in the tests.

The program included tests with both types of cold-formed steel panels; specifically, open sections and closed sections. The four wooden box-like structures, arranged in two different configurations, were used to support the test panels throughout the program.

The test results were presented in terms of visual observations, photographs of structural damage, measurements of permanent deformations of the test panels, pressure histories recorded by the gages, and overpressures at the four test structures.

An evaluation of the test results indicated that the test panels exhibited considerably greater blast capacities than those predicted by earlier criteria. Specifically, the strengths exhibited by the test panels were significantly greater than their computed strengths. The test panels were able to sustain larger than anticipated plastic deformations without suffering severe damage or complete failure. It was apparent that open type cross sections performed as well under the blast loads as closed type cross sections.

The accumulated data indicated that the increased strength observed in the test panels was due to the actual static stresses (which exceeded the minimum stress at yield of 227,500 kPa [33,000 psi]). It was further determined that the flexural resistances of a simply fixed panel or a continuous panel of equally spaced spans should be computed using the following equation:

$$r_u = 4(M_{un} + 2M_{up})/L^2$$

where r_u is the resistance per unit length of the panel, M_{un} is the ultimate negative moment capacity for one-foot width of panel, M_{up} is the ultimate positive moment capacity for one-foot width of panel, and L is the length of the panel.

The tests revealed that the maximum ductility ratio criteria of 1.25 for usable structures and 1.75 for nonreusable structures can be increased to 3.0 and 6.0, respectively. Other determinations included: (1) the total moment of inertia should be substituted for the effective moment of inertia when calculating the natural period and elastic deflections, (2) open hat shape panels can be used for closed sections in low pressure ranges, and (3) standard screw-type connections performed adequately in blast tests up to 34.5 kPa (5 psi).

BENEFITS

Criteria were developed which can be used to design steel panels to strengthen pre-engineered buildings at explosives manufacturing and storage facilities.

IMPLEMENTATION

The information developed from this project was used to update the safety regulatory document TM 5-1300.

MORE INFORMATION

To obtain additional information contact the program manager, Mr. J. R. Marsicovete, ARRADCOM, AV 880-3906 or Commercial (201) 328-3906.

Summary Report was prepared by Peter Martin, Manufacturing Technology Division, US Army Industrial Base Engineering Activity, Rock Island, IL 61299.

NON-METALS

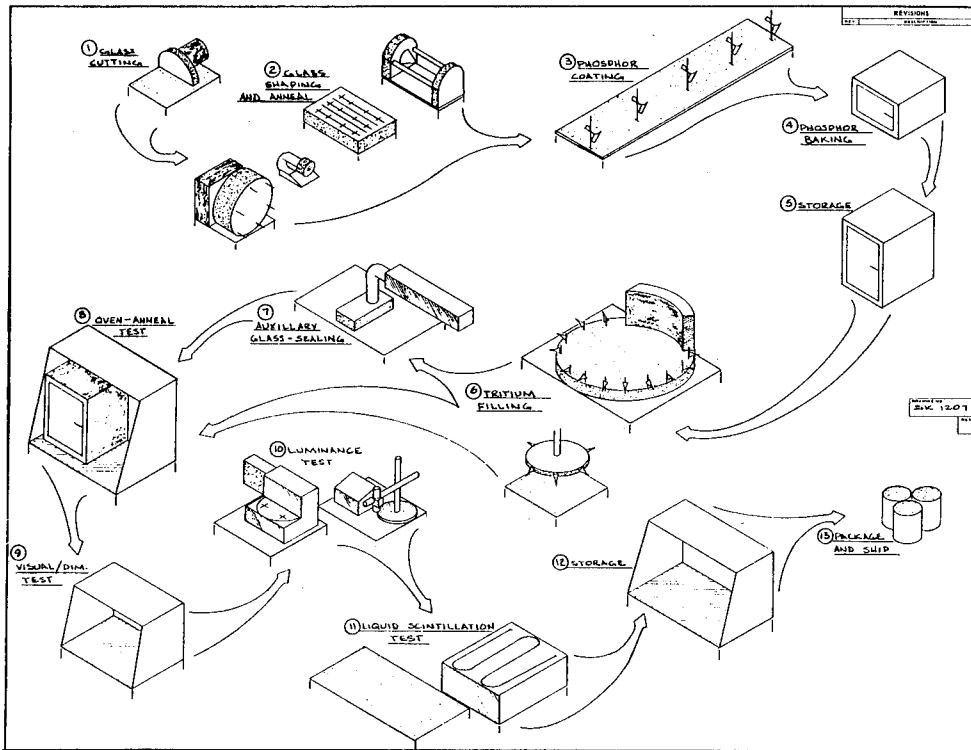

SELF-LUMINOUS LIGHT SOURCE PROCESS

MANUFACTURING METHODS AND TECHNOLOGY
PROJECT SUMMARY REPORT
(RCS DRCMT-302)

Manufacturing Methods and Technology Projects 376 3229, 37T 3229 and R78 3229 titled, "Methodology for Producing Low Cost/Disposable Mandrels" were completed by the US Army Missile Command in March 1981 at costs of \$147,800, \$30,000 and \$259,000, respectively.

BACKGROUND

Current and future solid rocket systems such as SAM-D, ATI, CHAPARRAL, LRGM, 2.75, MLRS and VIPER (ILAW) utilize expensive core mandrels for casting the solid propellant grains. The mandrels and their removal represent a significant portion of the tooling costs for a missile propulsion system. These mandrels are presently fabricated from steel or aluminum alloys and require many reuses. The development of a low cost or disposable mandrel which can be easily removed after propellant cure or left in the motor and fragmented or consumed on ignition will greatly reduce these costs.

SUMMARY

The purpose of this project was to establish the manufacturing methodology for producing low cost/disposable mandrels for solid propellant rocket motors. The first step (Phase I) was to carry out comprehensive process engineering studies to determine the recurring and nonrecurring costs associated with manufacturing 2.75-inch SEAS and VIPER type rocket motors using both conventional reusable metal mandrels and disposable (throw-away) plastic mandrels. In addition, extensive evaluations of candidate mandrel plastic materials as to cost, fabrication techniques, structural characteristics, compatibility with propellant, and dimensional control were conducted. The results of these 1976 and 1977 studies and evaluations led to the following conclusions:

1. The cost of using the conventional reusable metal mandrel concept in SEAS and VIPER motor applications is less than half the cost of using a hard disposable mandrel.

2. There are strong indications that "foamed" leave-in-place mandrels provide economic as well as other benefits compared to conventional metal mandrels.

Phase II (1978) of the program was devoted to develop "foamed" leave-in-place mandrels for free flight rocket type motor applications. Polyurethane foamed with fluoro-carbon (F-11) and water was the selected mandrel material. Figure 1 is a photograph of a finished mandrel.

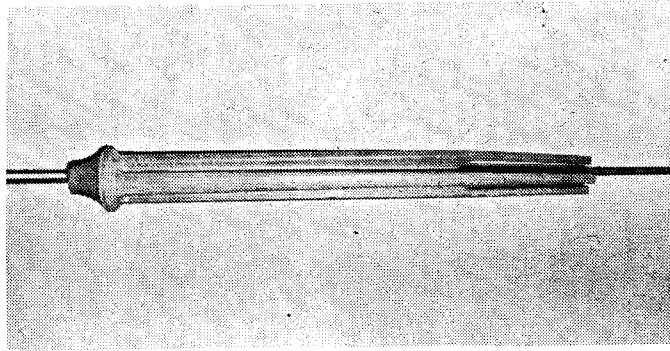

Figure 1 - Polyurethane Foamed Mandrel

A set of mandrels was made and the six best mandrels were chosen and loaded into cases. One motor was static tested and the ignition and mandrel extrusion phase went well. A nozzle malfunction delayed the testing of the last five motors. A production run was made and the mandrels produced were a better quality product.

BENEFITS

The net per use cost of leave-in-place foam mandrels is generally lower than for reusable tooling. Only in long production runs does the latter even approach a breakeven situation. The leave-in-place foam concept also provides several benefits that come from the design of the foam core itself. They include a self-contained nozzle closure/environmental seal, a built-in-stress-relief/core centering bulb and a support for the lead wires of the igniter assembly.

IMPLEMENTATION

The leave-in-place foam mandrel concept will be utilized in the MLRS rocket motor for stress relief for the grain configuration. It is also under serious consideration for use in an updated Pershing II and a new helicopter launched rocket system.

MORE INFORMATION

Additional information can be obtained from Mr. Seiford F. Schultz, MICOM, AV 746-2638 or Commercial (205) 876-2638. The contractor report, "Methodology for Producing Low Cost/Disposable Mandrels," Technical Report RK-CR-80-2, dated December 1979, describes the program and work in considerable detail.

Summary Report was prepared by Wayne Hierseman, Manufacturing Technology Division, US Army Industrial Base Engineering Activity, Rock Island, IL 61299.

MANUFACTURING METHODS AND TECHNOLOGY

PROJECT SUMMARY REPORT

(RCS DRCMT-302)

Manufacturing Methods and Technology Project 576 1311 titled, "MMT for the M229 Refill Kit Component of the Chemical Agent Alarm," was completed by the US Army Armament Research and Development Command in June 1981 at a cost of \$570,000.

BACKGROUND

The M8 Chemical Agent Alarm system is a device used to warn soldiers that a chemical agent is present so that protective measures can be taken. The system consists of five components: the M43 Detector; M42 Remote Alarm; M10 Power Supply; M229 Refill Kit; and BA3517 Battery. The M229 Refill Kit is required to maintain the operation of the M43 Detector. This refill kit consists of filter paddles, reservoir jars, and simulant bottles, all packaged and inclosed in a cardboard box. One refill kit will maintain one M43 Detector for a 30-day continuous operation. A mobilization requirement existed to provide a capability for producing 40,000 refill kits per month. The present methods were virtually hand operations, cumbersome and costly.

SUMMARY

The objective was to design a semi-automatic production line capable of producing 40,000 kits/month. Consideration was given to stockpiling a sufficient quantity of refill kits to meet mobilization requirements; however, the two-year shelf life of the refill kit precluded this. After production rates were established for the various components of the kit, the quantities of materials needed to sustain production were determined and provisions were made to receive and store them. The individual production operations were detailed, and preliminary engineering drawings were prepared for the various operating stations. These operations were combined in a preliminary facility layout and engineering drawings were finalized.

A flow diagram indicating the essential operations for production of the refill kit is shown in Figure 1. The production of the kit required many individual operations. Some of these could be easily automated since commercial equipment was available while others needed further developmental work.

For example, the capsule and filter assembly operations required unique equipment not available commercially. A machine was needed to assemble the air filters at a rate of 80 per minute. The air filter disks had to be punched out of three different materials, placed between a filter paddle and a plastic insert, and ultrasonically welded together. For the capsule, a

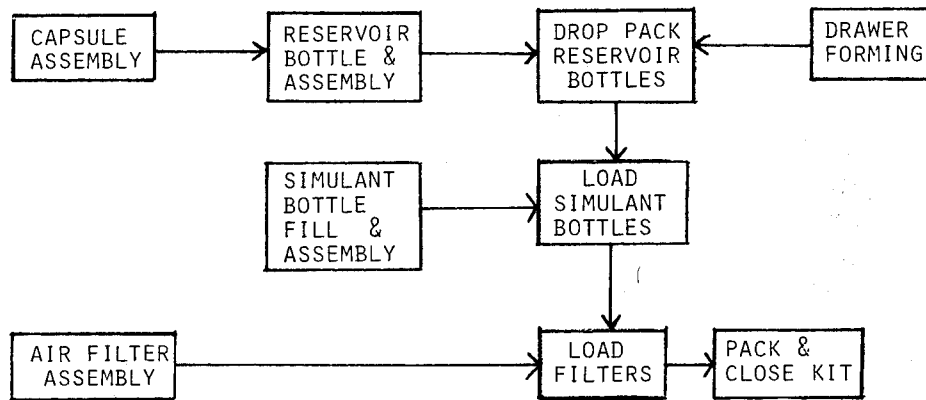

Figure 1 - Flow Chart of Refill Kit Operations

machine was required to assemble the capsules at a rate of 40 per minute. The capsule was formed by heat sealing a disk of polyester material to a plastic washer, filling the pocket with isonitrosobenzoylacetone (IBA) powder, and heat sealing a disc of polyethylene material to the washer to close the pocket. A contract was let for the design and fabrication of prototype machines for both of these operations. The machines developed, however, were not able to meet the production rate required. Additional efforts would be required to correct the design to meet the production rate.

For the remaining operations, various automated and semi-automated machines were selected and recommended for the production facility. The following descriptions indicate the equipment necessary for some of these major operations.

For the reservoir bottle operation, a machine was recommended which would fill the reservoir jars with buffer solution at a rate of 60 jars per minute. An unscrambler would be used to feed the jars. After filling the jars, the caps would be torqued automatically.

In the simulant bottle step, the bottles would be automatically filled at a rate of four per minute. This would be followed by plugging, capping, and sealing operations done automatically.

In order to load the reservoir bottles, a drop packing machine was recommended. This would allow 15 jars to be dropped into each drawer of the refill kit. The jars would be loaded at a rate of 60 per minute.

The drawer assembly operation required a machine to form a drawer blank, seal it, and discharge it with open flaps, for insertion of dividers and subsequent packaging. The machine recommended could produce in excess of the rate of four per minute required.

After loading the reservoir bottles, simulant bottles and filters, the two kit drawers are packaged. The present means was to insert them into a sleeve, manually strap and buckle the sleeve, and insert them into a fiberboard box. It was determined that both coverings were unnecessary and the box could be modified to accept only the drawers. By eliminating the sleeve, strap, buckle, and modifying the box, a cost savings of \$1.56 per kit was estimated.

In the final step, the kits were to be packed at a rate of two per minute. A machine was available which could form the fiberboard box, load the kit, seal the bottom of the box with hot-melt glue, and fold the top flaps over for taping. The machine was totally pneumatic with the exception of the hot-melt gluer.

BENEFITS

This project provided the design information and an equipment list necessary to establish a production facility for manufacturing of mobilization quantities of M229 Refill Kits. This design information has reduced the estimated time required to build a facility in the event of mobilization. A cost savings of \$1.56 per kit has been realized through an Engineering Change Proposal for modifying the packaging.

IMPLEMENTATION

The design information will be used in the event of mobilization, however, current production rates do not economically warrant the establishment of this facility now.

MORE INFORMATION

Additional information can be obtained by contacting Mr. R. Vigus, ARRADCOM, AV 584-4424 or Commercial (301) 671-4424.

Summary Report was prepared by Pete Martin, Manufacturing Technology Division, US Army Industrial Base Engineering Activity, Rock Island, IL 61299.

MANUFACTURING METHODS AND TECHNOLOGY
PROJECT SUMMARY REPORT
(RCS DRCMT-302)

Manufacturing Methods and Technology Project 577 1312 titled, "Manufacturing Methods and Technology for Paper, Chemical Agent, Detector, M8," was completed by the US Army Armament Research and Development Command in December 1980 at a cost of \$118,000.

BACKGROUND

The chemical agent detector paper, M8, is a component used in several chemical agent detector kits. It consists of a booklet containing 25 sheets of chemical detector papers. Each sheet contains three indicator pigments which react with liquid toxic chemical agents to produce a color change. In the present production process for manufacture of M8 paper, three dyes are blended with paper pulp which only retains 50% or less of the dyes in the paper fibers. Remaining dye drains through the paper with the water waste resulting in a minor disposal problem. An improved manufacturing process would retain 90 to 100% of the dye by incorporating a retention agent into the basic paper making process. This would result in dye costs being reduced to at least one-half their present costs and would eliminate the disposal problem. An investigation was initiated to determine if retention aids could be used during M8 paper manufacture to reduce pigment losses.

SUMMARY

The main objective of this project was to determine the feasibility of increasing the pigment retention in the M8 paper during manufacture. In addition, the retention aids which yield the best results and economic savings were determined. The project for M8 paper was carried out in two phases. In Phase I, handsheets were prepared under static conditions and analyzed to screen the various retention aids available. Phase II consisted of pilot-scale paper runs which were conducted to simulate a dynamic paper process.

Prior to the Phase I and II studies, a special water filtration system had to be installed in the handsheet and pilot paper machine facility at Chemical Systems Laboratory (CSL). This was because M8 paper pigments were found to be mutagenic and carcinogenic. Therefore, any human exposure or release of the pigments to the environment had to be prevented. Pigments had to be kept in a water slurry form and weighings were conducted within a glovebox. Personnel were required to wear disposable gloves and lab coats when handling the pigments or M8 paper.

In Phase I, handsheets were prepared containing the basic formulation of the M8 detection paper with and without retention aids. Eight retention aids were evaluated. The retention aids were high molecular weight polymers which have a tendency to loop around pulp fibers causing them to flocculate into bundles. The retention aid formed bridges between the bundles linking them together. This produced a matting of pulp fibers to which the fine pigment particles can become attached through both electrostatic attraction and impingement. The retention aids evaluated were cationic type (positively charged) and therefore should attract the negatively charged pigment particles. Two out of the eight retention aids were selected for further study in the Phase II, pilot-scale paper runs.

The Phase II, pilot-scale paper runs were performed on a 12-inch wide Fourdrinier paper forming machine wet press and dryer machines at the pilot paper facility located at CSL, Aberdeen Proving Ground, Maryland. A photograph of the wet press machine is shown in Figure 1. The facility included an in-process control laboratory and an isolation room in which the mutagenic/carcinogenic pigments could be prepared in a safe environment. The facility was equipped with an efficient water filtration system capable of removing the fine particles of M8 paper pigments from the stream. The effluent was monitored constantly prior to its release into the sewer system.

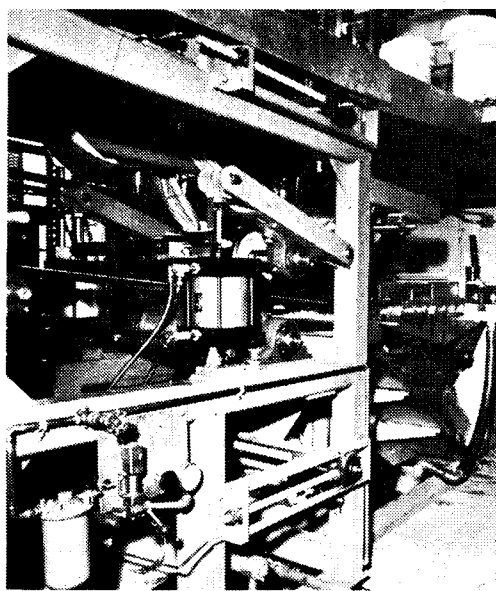

Figure 1 - Wet Press Machine

Eight paper runs were conducted utilizing the two cationic retention aids identified in Phase I and an anionic (negatively charged) retention aid. The results indicated that the use of retention aids (cationic, anionic) at certain concentrations increased indicator pigment retention. Optimum results

were obtained by using a cationic aid (Betz 1120) at 0.01 percent concentration which furnished a retention increase of 11.5 percent.

Work conducted during this investigation was performed using laboratory and pilot size equipment. Scale up to commercial size equipment could slightly change these findings. Commercial manufacturers, therefore, should evaluate these findings on an individual basis for adaption to their particular systems. Evaluation should start with a cationic retention aid at a concentration of 0.01 percent.

BENEFITS

The results of this project demonstrated the use of retention aids for increasing the retention of pigments in M8 detection paper. Cost savings will be realized since less dye would be required for the same amount of production and the waste disposal problem will be reduced.

IMPLEMENTATION

An Engineering Change Proposal (ECP) was prepared and approved requiring paper manufacturers to use retention aids during M8 paper production.

MORE INFORMATION

Additional information can be obtained by contacting Mr. P. Annunziato, ARRADCOM, AV 584-4424 or Commercial (301) 671-4424.

Summary Report was prepared by Pete Martin, Manufacturing Technology Division, US Army Industrial Base Engineering Activity, Rock Island, IL 61299.

MANUFACTURING, METHODS AND TECHNOLOGY

PROJECT SUMMARY REPORT

(RCS DRCMT-302)

Manufacturing Methods and Technology Project 577 4481 titled, "Pyrolysis of Army Ammunition Plant Solid Waste," was completed by the US Army Armament Research and Development Command in June 1979 at a cost of \$100,000.

BACKGROUND

Army ammunition plants (AAP) dispose of large quantities of neat explosives and contaminated waste by either open air burning or incineration. These disposal techniques do not address the concept of energy recovery even though the waste has an estimated heating value of 6000 BTU/lb. Because it was in the Army's best interest to capture some of this available energy, a pyrolysis disposal method that could achieve this objective was selected for evaluation.

Pyrolysis is the thermal degradation of organic matter in the absence of air. Using this process, refuse can be converted into the three physical states of matter: gas, liquid, and solid. The relative proportion produced of each of these states can be controlled to some degree by the choice of operating parameters and the composition of the refuse. The resulting liquid and solid fuel products can be stored and reserved for future use. The ability of the pyrolysis process to produce fuels that can be used immediately or at some future date made it the preferred candidate for investigation.

SUMMARY

This project was the first year of a planned three year effort. Its objective was to perform an engineering analysis of candidate pyrolysis systems and identify one that would permit the safe disposal of explosives and explosive contaminated waste while producing a storable fuel. Because of the hazardous potential of this waste, extreme caution during the investigation was to be exercised to safeguard against any unexpected occurrence during the pyrolysis reaction. Therefore, pilot plant scale investigations were planned to establish the technological basis for scaling up to a production scale system. A pilot plant, scaled to one-tenth of the capacity of a production plant, was to be capable of converting five tons per day of AAP waste into usable fuel. The factors that were deemed to be of major importance in this investigation were the process operating parameters (pressure, temperature, and fuel usage), quantity and quality of recovered fuel (gas, oil, and char), and system complexity.

Contracts were awarded to broaden and accelerate the investigative process. One contractor conducted a six-part program to assess the applicability of pyrolysis technology to AAP type of waste. His program

included: (1) an AAP waste survey, (2) a literature search of pyrolysis technology, (3) a hazard analysis, (4) an evaluation of candidate systems, (5) estimated costs for five-ton per day pyrolysis pilot plants, and (6) an economic analysis of pyrolysis under current and mobilization production levels. This contractor concluded that five processes were capable of producing a liquid fuel from explosive contaminated waste. Of the five, only three appeared to be acceptable from the standpoint of environmental, energy recovery, and technical development. However, the economic analysis showed that even a 45.4 Mg/d (50 TPD) pyrolysis plant would not generate enough revenue to make it economically attractive, even under mobilization conditions. The price of oil would have to reach approximately \$55 per barrel to meet the break even point.

Another contractor was selected to determine the energy content of explosive contaminated waste. His investigation consisted of a series of laboratory scale pyrolysis runs on a variety of waste materials which had been mixed with small quantities of TNT. Runs were made with wastes containing 0.0, 0.5, 1.0, and 2.0 percent, by weight, TNT. The distribution of the energy yield is illustrated in Figure 1. The results showed that AAP waste can be safely processed, with no adverse environmental impact, to produce a storable fuel having a heat content of 14,000 BTU/lb (31.3 MJ/kg) with an energy conversion efficiency of approximately 70%.

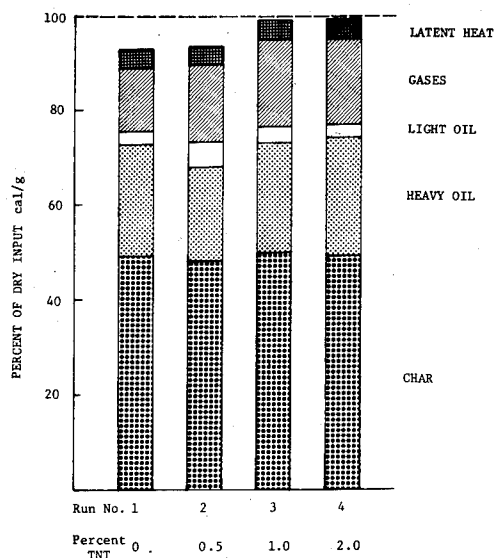

Figure 1 - Energy Yield Distribution

As a result of these investigations, it was concluded that it would be possible to pyrolyze waste contaminated with propellants, explosives, and pyrotechnics safely with proper precautions. It was determined that 45.4 Mg/d (50 TPD) plant would be sufficient to handle the largest quantity of waste generated at any AAP. Capital costs were estimated at \$4.1 million and annual cost at \$623,100. Based on these costs it was concluded that pyrolysis was not economically feasible at this time even under mobilization conditions.

BENEFITS

The ability to pyrolyze explosive contaminated waste safely was demonstrated. Sufficient operational and economic data were obtained to justify the curtailment of the planned three year effort at the completion of this project.

IMPLEMENTATION

Since the economic analysis showed that the pyrolysis of AAP waste was not economically viable, the second and third years of the planned effort were cancelled.

MORE INFORMATION

Additional information can be obtained from Mr. R. Scola at ARRADCOM, AV 880-3360 or Commercial (201) 328-3360. The following reports were prepared for this project:

"Wood - The Renewable Fuel", ARLCD-TR-78051, LCWSL, February 1979.

"Laboratory Study of Pyrolysis of Explosive Contaminated Waste," ARLCD-CR-78027, LCWSL, February 1979.

"Energy Recovery from Army Ammunition Plant Solid Waste by Pyrolysis," ARLCD-CR-78030, March 1979.

"Hazard Analysis of Energy Recovery from Army Ammunition Plant Solid Waste," ARLCD-TR-78080, LCWSL, April 1979.

Summary Report was prepared by A. Kource, Manufacturing Technology Division, US Army Industrial Base Engineering Activity, Rock Island, IL 61299.

MANUFACTURING METHODS AND TECHNOLOGY
PROJECT SUMMARY REPORT
(RCS DRCMT-302)

Manufacturing Methods and Technology Projects 579 4084 and 580 4084 titled, "Opacity/Mass Emission Correlation Study," were completed by the US Army Armament Research and Development Command in June 1981. The project costs were \$101,000 and \$111,000 respectively for each of the funded years.

BACKGROUND

Present methods of large caliber ammunition production, especially the forging operations, result in smoke emissions that are strictly regulated by the Environmental Protection Agency (EPA). The EPA will soon be enforcing regulations that require each plant to monitor its own opacity and mass emissions. Unfortunately, the ammunition plants do not possess the required equipment or experience to meet these regulations. In order to prevent court action that could result in fines and shutdowns, the plants would be forced to rely on frequent, periodic monitoring studies contracted to private industry or to purchase expensive mass-monitoring equipment.

Preliminary studies indicated that use of available and inexpensive opacity monitors to measure and record mass as well as opacity was feasible. Establishing a correlation between opacity reading and mass emission rate and an inexpensive opacity monitor would be well suited to meet the new EPA regulations.

SUMMARY

The primary objective of this study was to determine if an empirical relationship between opacity and particulate mass concentration could be established. The study was to describe this relationship for the purpose of estimating particulate mass emissions from opacity data recorded at other similar plant forging operations.

Initially, the study involved the determination of opacity and mass emissions at the forging areas of large caliber metal parts facilities. The major effort of the study was to perform a technical evaluation of the uncontrolled exhaust at the Erie press line at the Scranton Army Ammunition Plant (SAAP) operated by Chamberlain Manufacturing Corporation in Scranton, Pennsylvania. Technical evaluation consisted of performing numerous particulate emission tests, concurrent with the operation of a transmissometer, as well as analyzing process operating conditions. To evaluate emission and process characteristics at different forging facilities, two additional forge shops were visited. Particulate emission and opacity tests were performed at the forging facility of Flinchbaugh Products, Inc. in Red Lion, Pennsylvania, while process and opacity observations were recorded at the forge shop of

Chamberlain Manufacturing Corp. in New Bedford, Massachusetts. These additional plant inspections provided a basis for evaluating emission characteristics between forge shops.

A primary concern in this study was to choose a sampling location where there was an adequate length of straight ductwork prior to the sampling ports. At both the Erie Pass line and the Flinchbaugh forge shop the choice of sampling location was limited. Figure 1 illustrates the sampling location for the Erie press line at SAAP.

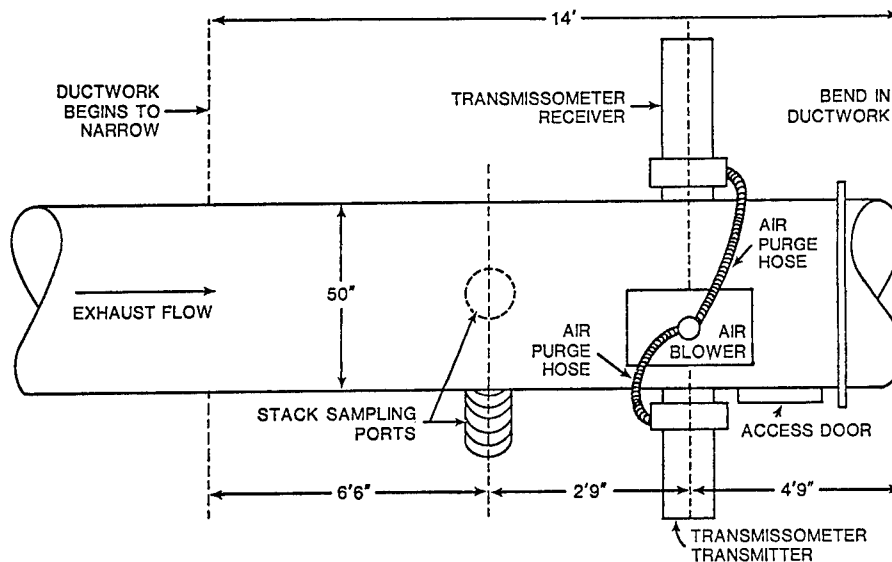

Figure 1. Sampling Location on the Horizontal Ductwork (View from Above) Coming from the Erie Press Line at the Scranton Army Ammunition Plant (SAAP), Scranton, PA.

Based on the results of 48 particulate emission tests and corresponding optical density values derived from concurrent transmissometer data, it was concluded that a strong correlation between particle concentration and optical density does exist at the 95 percent confidence level. Through a least squares linear regression analysis of the 48 paired data points, the best fit line for the total data base was defined by the following equation:

$$D = 3.49C$$

where D = optical density (expressed as a fraction, $0 < D < 1$)

C = particle concentration (gr/acf)

It is reasonable to predict particle concentration values from measured values of optical density (or opacity) by using the preceding empirical

relationship. Eighty-three percent of the variation of optical density values can be attributed to variation in particle concentration. Variations in particle size distributions can account for a portion of the remaining seventeen percent. Strictly speaking, it is recommended that the functional relationship derived from this study be limited to use on the exhaust of the Erie press line at the SAAP. There is no information generated by this study which supports the use of this empirical relationship for other forge shop exhausts, unless the emission characteristics are known (by testing) and the empirical relationship between particle concentration and optical density is tested.

However, for predictive estimates of particle concentrations, the empirical relationship could be used at other forge shops provided the forging operations are similar in most respects to the Erie press line and the diameter of the exhaust ductwork is known. Opacity observations could be made at the outlet of the exhaust using EPA Method 9 procedures. The average opacity values over one-hour periods or more could then be corrected to account for the difference in stack diameter between a given forge shop exhaust and the Erie press line exhaust. Once the corrected average opacity is converted to optical density, an estimate of particulate concentration may be obtained.

BENEFITS

A correlation was established between particle concentration and opacity which can be used as an alternative to more expensive traditional mass emissions testing for any large caliber facility.

IMPLEMENTATION

The correlation developed was made available to large caliber metal parts facilities, such as SAAP, LAAP, and MSAAP to meet EPA self-monitoring requirements.

MORE INFORMATION

To obtain additional information, contact the project officer, Mr. J. T. Clancy, Jr., ARRADCOM, AV 880-3404 or Commercial (201) 328-3404.

Summary Report was prepared by Pete Martin, Manufacturing Technology Division, US Army Industrial Base Engineering Activity, Rock Island, IL 61299.

MANUFACTURING METHODS AND TECHNOLOGY

PROJECT SUMMARY REPORT

(RCS DRCMT-302)

Manufacturing Methods and Technology Projects 672 7062 and 673 7062 titled, "Optical Polishing Technology," were completed by the US Army Armament Materiel Readiness Command in June 1975 at a cost of \$100,000.

BACKGROUND

The polishing of high precision optics required for military applications is time-consuming and expensive. Up to two hours are needed for a complete polish in an operation that can account for approximately two-thirds of the cost of the lens.

Currently, two types of lens polishing machines are available and their application is dependent upon the radius of curvature of the lens. The conventional polishing machine is used for finishing optical flats or lenses with a relatively large radius of curvature. Several lenses are mounted on a spherical block which is spun along a vertical axis. Polishing is accomplished by a tool that applies downward pressure to the rotating block. This machine is capable of polishing the majority of lenses, but a different machine is needed for finishing lenses having a short radius of curvature, since downward tool pressure will not effectively polish such a sharply-curved block of lenses. In this case a radial machine is used where the applied pressure is not downward, but normal to the surface of the lens block. Pressure is applied hydraulically along the lens' radius and is independent of gravity.

SUMMARY

The objective of this project was to design and build a universal lens polishing machine in order to reduce production time and cost. Work in the first year investigated all aspects of standard polishers in an effort to determine optimum operating parameters. In the second phase, a polisher was designed and built based on a modified Strasbaugh polisher. The model incorporated features of both radial and conventional machines.

The modified polisher retained the existing spindle rotating the lens block but required that a new radial polishing tool be designed. Pressure for the polishing head was supplied by a hydraulic cylinder mounted in a frame. To keep the tool in a radial orientation the frame pivoted in an arc concentric to the curved surface of the lens block. The polishing tool was adjusted to the correct radius of curvature by means of a variable pantograph arm. This was done manually by bringing the tool head in contact with the lens block and locking the arm in place. See Figure 1.

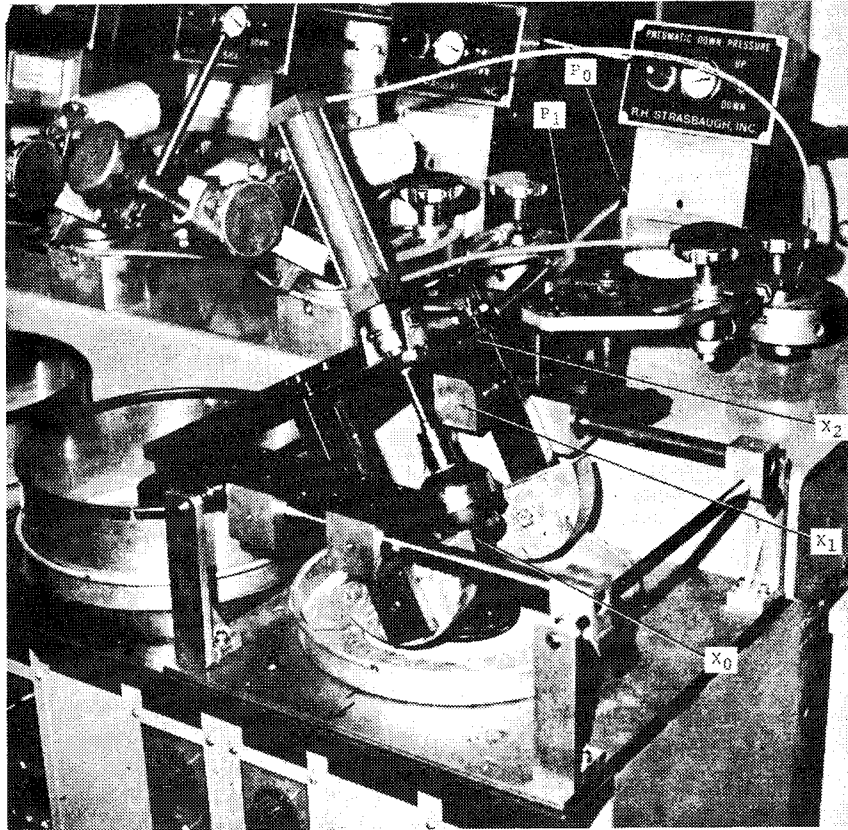

Figure 1 - Modified Machine with the Upper Spindle
30 degrees from the Vertical

A variety of lenses were polished using the modified device but the results were generally poor. No reduction in polishing time was observed, and thus improvement in production cost was not realized. After analyzing the results, problem areas were identified in both the machine design and the overall concept. A significant flaw in the design involved the limited angle through which the polisher head could travel. This problem was especially acute with hemispherical lens blocks, causing inefficient finishing of the lenses at the edge of the block. A more serious flaw was the incorrect assumption that the radial design is inherently more efficient. The fact that the radial machine is specialized for short-radius lenses limited the usefulness of the new design since only small lens blocks can be accommodated by the radial polisher.

BENEFITS

This project demonstrated the impracticality of designing a universal lens polishing machine. By doing so it established the specific advantages of the existing radial and conventional polishing machines.

IMPLEMENTATION

A technical report was distributed to government agencies and to industry. No further implementation is scheduled for this technically unsuccessful effort.

MORE INFORMATION

Additional information regarding high-speed lens polishing may be obtained by contacting Mr. Nate Scott, ARRADCOM, AV 880-6430 or Commercial (201) 328-6430. The report number for this project is FA-TR-75067.

Summary Report was prepared by Charles Miller, Manufacturing Technology Division, US Army Industrial Base Engineering Activity, Rock Island, IL 61299.

MANUFACTURING METHODS AND TECHNOLOGY

PROJECT SUMMARY REPORT

(RCS DRCMT-302)

Manufacturing Methods and Technology Project 674 7271 titled, "Glass Coated Plastic Optics," was completed at Frankford Arsenal in June 1975 at a cost of \$50,000.

BACKGROUND

A major problem with plastic optical elements is their susceptibility to surface abrasion. Attempts at reducing this vulnerability have had only limited success. One method involved the use of organic films such as glass resins or fluorocarbon materials to increase the surface hardness of the plastic. Although this improved surface durability, the optics could not pass the military abrasion test. Another attempt employed vacuum vaporization of inorganic materials. In addition to the high cost of this technique, the high temperature associated with it caused serious degradation of the plastic. A third method bonded a glass window to the plastic surface. Unfortunately, significant differences in the expansion coefficients of plastic and glass sometimes resulted in warping or delamination.

SUMMARY

This project was the second year of a two year effort to establish techniques for applying hard surface materials to plastic optics. It concluded work begun in project 673 7271, which explored electron-beam (EB) and radio frequency (RF) sputtering techniques to deposit glass on plastic.

The purpose of this second year effort was to evaluate processes that could be applied to plastic optical components to enhance their surface hardness and utility within a military environment. Plastic materials considered for surface treatment included acrylic, polycarbonate and CR-39 (allyl diglycol carbonate). Samples were prepared using both RF sputtering and electron beam evaporation. Sputtering work was done by Battelle Memorial Institute and EB evaporation coatings were made at Frankford Arsenal.

Radio frequency sputtering is done in a chamber evacuated to about 10^{-5} torr and backfilled with inert gas. Deposition begins when electrical potentials are applied to the source material (anode) and the target (cathode). By using alternating current in the range of 10 MHz, source ions will migrate and deposit onto the non-conducting plastic target. This method uses only two electrodes and is known as diode sputtering. A problem with this method is the generation of high target temperatures by electron and ion bombardment. Target overheating is alleviated by triode sputtering, a technique in which the plasma discharge field is independently formed by the source anode and a separate cathode. The negatively-biased target is then inserted between those two electrodes.

The second process employs electron beam evaporation, also performed in an evacuated chamber. In this system, a stream of high energy electrons is produced and magnetically focused on a source material. The electrons impinge on the material and liberate ions that are attracted and bonded to the target, which is biased with a negative charge. High energy levels are not associated with the target which remains at room temperature.

Various plastics were coated using the evaporation technique in a three-step process. For good bonding, the plastics were thoroughly cleaned and coated with an intermediate binder before being coated. The binder consisted of a deposit of chromium; this resulted in only a 0.25% increase in surface reflectance and a strong bond. The samples were then coated with Schott glass 8329 in thicknesses from 0.55 to 5.5 microns.

The coated samples were subjected to tests of adhesive strength, abrasion resistance, water solubility, and optical transmittance. None of the samples made by RF sputtering showed satisfactory adhesion or abrasion properties. However, good results were achieved using the CR-39 material with electron beam evaporation. The coating revealed no sign of water solubility, and high transmission and resolution characteristics were maintained. Most importantly, the CR-39 coated optics passed all abrasion tests indicating they would function in a military environment.

BENEFITS

The results of this work are applicable to fire control instruments containing plastic optics such as vision blocks, periscopes, and scales. The substitution of plastic for glass results in a 50% reduction in weight and provides for a safer working environment. Cost savings are anticipated when replacing plastic items that presently have short life cycles due to poor abrasion resistance.

IMPLEMENTATION

The results of this work have been implemented at the Optical Systems Lab at US Army Armament R&D Command and projected applications include optical assemblies in M6, M17, M27 and M45 Periscopes. Technical Report FA-TR-75041 was disseminated to government agencies and private industry. This technique has been reviewed and accepted by ophthalmic manufacturers for use in corrective vision lenses, and thus has benefited the civilian sector.

MORE INFORMATION

Additional information may be obtained from Mr. James Lester, ARRADCOM, AV 880-3582 or Commercial (201) 328-3582.

Summary Report was prepared by Charles Miller, Manufacturing Technology Division, US Army Industrial Base Engineering Activity, Rock Island, IL 61299.

MANUFACTURING METHODS AND TECHNOLOGY
PROJECT SUMMARY REPORT
(RCS DRCMT-302)

Manufacturing Methods and Technology Project 675 7497 titled, "Extended Use Optical Tooling," was completed at Frankford Arsenal in June 1976 at a cost of \$45,000.

BACKGROUND

Eighteen items of special tooling were required to make a precision lens. Since these tools finish the lens surface to a particular diameter and radius of curvature, the tooling could not be interchanged for the manufacture of lenses having different curvatures. This resulted in high tooling cost per lens manufactured and excessive tool inventory. There was need for a tooling system which had the flexibility to grind and polish a variety of lenses, could accommodate new lenses as they were designed, and reduce manufacturing cost and tool storage area.

This project is the second year of a two-year effort. In the first year, existing tools were categorized and tool range limits and lens blocking standards established.

SUMMARY

The project was originally concerned with developing a universal optical tooling system to reduce manufacturing cost. The conventional pitch block was replaced by the spot block, a hemispherical tool with machined cavities for positioning and holding several lens blanks. This fixture is shown to the right of a diamond grinding tool in Figure 1. Initial effort concentrated on improving the design of this fixture; although some success was reached in developing one for a variety of lenses, it was apparent that the concept of a universal spot block was not economically feasible. Work was then directed toward computerized tool design and numerical control (NC) manufacture.

Mathematics suitable for computer analysis were developed to calculate design parameters for spot blocks, grinders, and polishers. Application of the mathematics to the lens data yielded all dimensions needed to fabricate the tools for the lenses. Included was the precise distribution of cavities on the spot blocks. The algorithms were programmed in Fortran IV language using a Control Data 6500 computer. The program was capable of computing the following parameters for NC equipment: tilt increments, rotational increments, and Cartesian coordinates for tool-to-lens orientation. The machine control software was written to operate a Wadell lathe for turning and contouring, and a Cincinnati Cim-X equipped with a programmable rotary table with tilt capabilities for machining the spot blocks. All lens tools were mounted on a common adapter so that a datum could be used to simplify positioning.

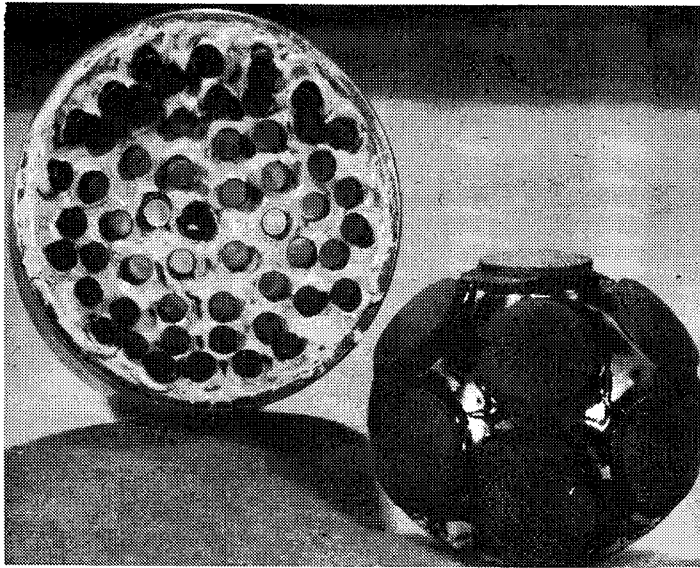

Figure 1 - Spot Block Shown to the Right of the Hemispherical Grinding Tool

Neither of the two NC machines was available when needed so a simulation was carried out under which an operator performed the computer-indicated moves. Milling was done on a conventional machine while contouring was performed on a Strasbaugh curve generator. An engine lathe was used for turning. Since NC machining is superior to manual methods in following instructions and repeatability, the simulated automation was judged to be valid. The completed tools were successfully used to make the lenses for which they were designed.

BENEFITS

This project provided the mathematics and a computer design program for the fabrication of tooling used in making precision lenses. It replaced the conventional pitch blocks with a more efficient spot block mounting fixture. Tool fabrication cost will be reduced when NC methods are used in lieu of operator-assisted machining. Actual savings cannot be determined until tooling is made on the NC machines and costs compared against those incurred in conventional production methods. Savings are also anticipated in the production of lenses, since the spot block reduces both setup and production times.

IMPLEMENTATION

The results of this technically successful project were not implemented due to unavailability of suitable facilities. Numerical control machining techniques using spot blocks have been independently developed and applied by commercial manufacturers. Final Report FA-TR-7607 has been distributed to government agencies and industry.

MORE INFORMATION

Additional information may be obtained from Mr. Nathaniel Scott, ARRADCOM, AV 880-6430 or Commercial (201) 328-6430.

Summary Report was prepared by Charles Miller, Manufacturing Technology Division, US Army Industrial Base Engineering Activity, Rock Island, IL 61299.

MANUFACTURING METHODS AND TECHNOLOGY
PROJECT SUMMARY REPORT
(RCS DRCMT-302)

Manufacturing Methods and Technology Project 678 7933 titled, "MM&T: Central Coolant Systems," was completed by the US Army Armament Research and Development Command in June 1980 at a cost of \$58,000.

BACKGROUND

Currently a variety of machine tools at Watervliet Arsenal use identical water soluble coolants. The machine tools are used intermittently and a lack of agitation allows stagnation and, consequently, a bacterial build-up. Eventually this bacteria build-up destroys the coolant and then the coolant must be replaced. The cost of replacement materials, the labor required for maintenance, and the manufacturing problems caused by the recurrence of contaminated coolants are the major elements of the manufacturing problem. This effort was undertaken to determine the feasibility of using central coolant control systems at Watervliet Arsenal. Similar systems have been installed at several industrial sites.

SUMMARY

The objective of this project was to reduce the cost of material removal through more judicious use of coolant oil systems. The approach was to perform a study and recommend an economic central coolant system configuration. The study was conducted in the minor components manufacturing section which employs a large number of small machine tools. Many types of liquid clarification methods were investigated along with their advantages and limitations.

The following methods were ruled out for economic or technical considerations: (1) gravity or settling tank, (2) hydrocyclone clarifiers, and (3) tubular filtration.

A vacuum filtration system was recommended, see Figure 1. The proposed configuraton would consist of a water deionizer, liquid proportioner, coolant make-up tank, reservoir-main filter unit, centrifuge, clean coolant lines, dirty coolant lines, and control and monitoring equipment.

Recommendations and guidelines for the specific requirements for each element of the system were identified for inclusion in a proposed procurement package. A proposed coolant system for a multi-story building at Watervliet Arsenal is illustrated in Figure 2. Inserts in Figure 2 illustrate the typical flume junction cross section and top view of floor flumes.

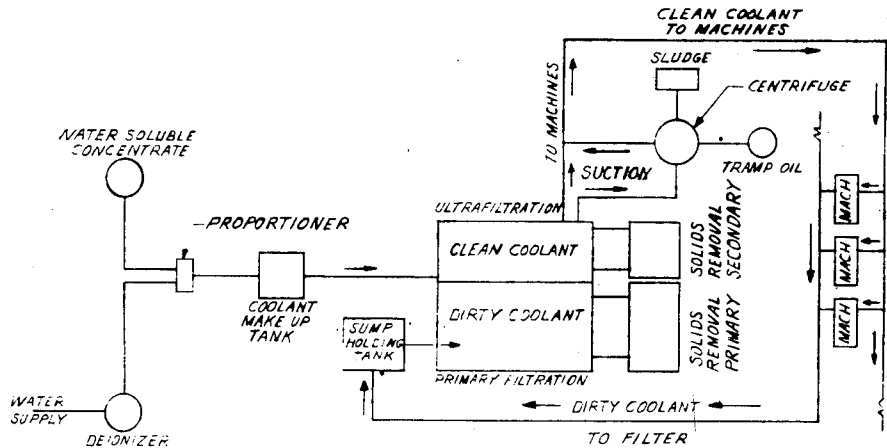
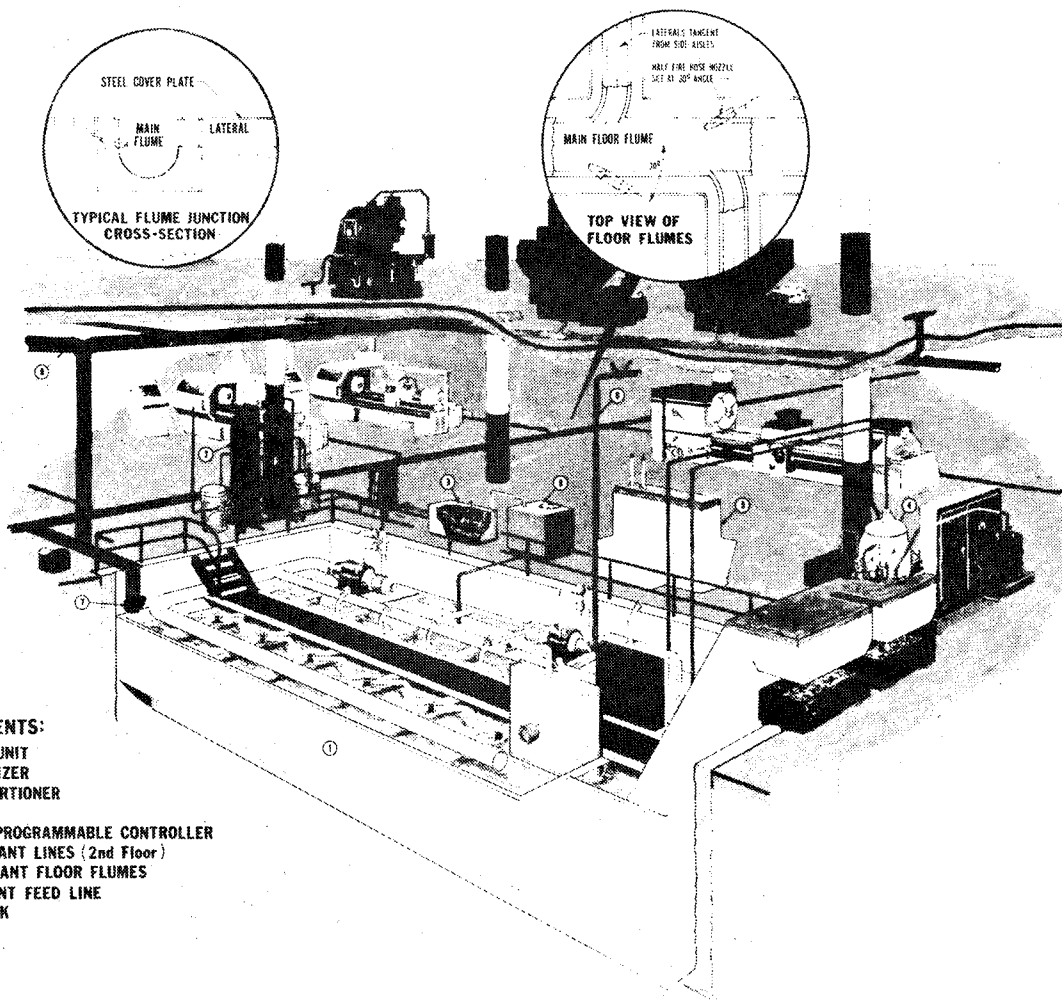

Figure 1 - Central Coolant System



COMPONENTS:

- ① MAIN FILTER UNIT
- ② WATER DEIONIZER
- ③ LIQUID PROPORTIONER
- ④ CENTRIFUGE
- ⑤ SOLID STATE PROGRAMMABLE CONTROLLER
- ⑥ RETURN COOLANT LINES (2nd Floor)
- ⑦ RETURN COOLANT FLOOR FLUMES
- ⑧ CLEAN COOLANT FEED LINE
- ⑨ MAKE-UP TANK

Figure 2 - Artist's Illustration
Central Coolant System

BENEFITS

Estimated annual savings from using the proposed central coolant system are \$260,000 when compared with maintaining sumps on 400 machine tools. The savings will be in reduced labor for coolant maintenance and less consumption of coolant oils. The results of this project are being used for the planning of several proposed coolant systems at Watervliet Arsenal.

IMPLEMENTATION

Additional facility studies, and equipment layout studies need to be completed to firm up detail design requirements. Coolant systems are planned for Building 25 and for the honing production area at Watervliet Arsenal. Mr. Robert Wooding is the Watervliet Arsenal project officer responsible for the design and installation of these coolant systems. The initial coolant system is anticipated to be operational by October 1983.

MORE INFORMATION

Additional information can be obtained on this study from Mr. Rocco Demeo, ARRADCOM, Benet Laboratories, Watervliet, NY 12189, AV 974-5611 or Commercial (518) 266-5611.

Summary Report was prepared by Stephen McGlone, Manufacturing Technology Division, US Army Industrial Base Engineering Activity, Rock Island, IL 61299.

MANUFACTURING METHODS AND TECHNOLOGY
PROJECT SUMMARY REPORT
(RCS DRCMT-302)

Manufacturing Methods and Technology Project 773 8025 titled, "Manufacturing Techniques of 3D Fabrics," was completed by the US Army Materiel and Development Command Natick Laboratories in January 1977 at a cost of \$400,000.

BACKGROUND

Coated fabrics, in the conventional method for manufacturing double-wall air inflatable structures, must be fabricated so that the inner and outer faces have different radii, and these must be connected by webs properly fastened to the faces. The various operations for cutting, seaming and cementing require considerable labor and the inflatable modular sections thus produced contribute to the high cost of the finished shelters. The objective of this project was to develop three-dimensional weaving techniques which could produce integrally woven arch sections for inflatable double-wall structures.

SUMMARY

The fabrication method, developed under this effort, sought to achieve the following:

1. develop three-dimensional weaving techniques which could be used to manufacture integrally woven fabric for the wall sections of double-wall inflatable military structure,
2. develop an economical method to apply a protective coating of synthetic rubber on the exposed wall surfaces,
3. produce a three-section MUST (Medical Unit Self-Contained, Transportable) shelter, using the above techniques.

The technique for weaving double-wall inflatable material involves the simultaneous weaving of inner and outer face fabric and of webs joining these faces, with the cells formed by the webs in the warp direction of the fabric. The plan for producing this fabric included the following tasks: fabric and loom programming design; yarn procurement and preparation; loom modification; loom and creel set up; start up; weaving; fabric repair; and inspection. The objective of demonstrating the feasibility of weaving full-width double-wall inflatable fabric module sections was achieved. See Figure 1 for cross section design. Considerable mechanical problems were encountered and overcome in adopting a conventional wide fly shuttle loom with Jacquard programming. A shuttleless loom modified to accept draw rolls, and equipped with conventional harnesses, appears to be the best candidate equipment for weaving this type fabric in production quantities.

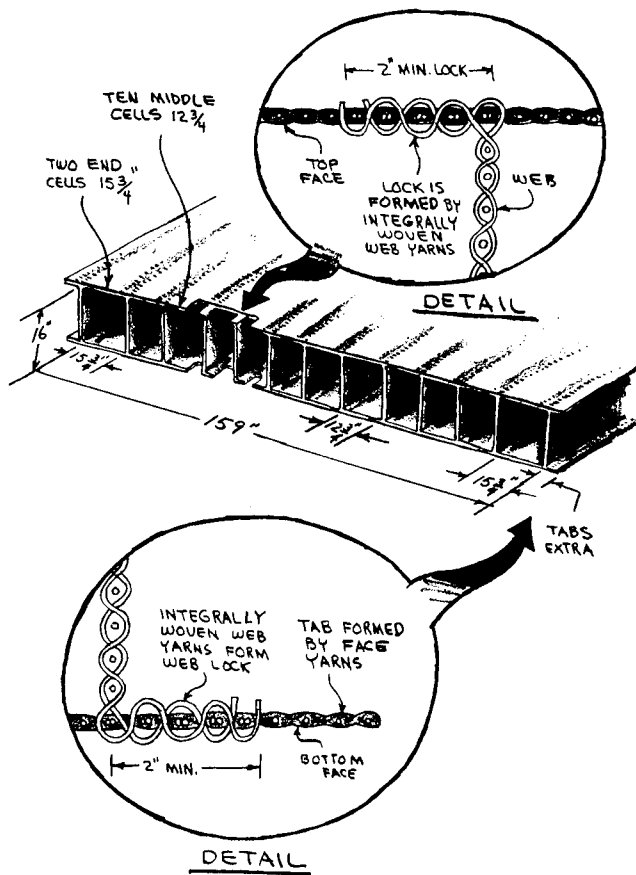

Figure 1 - Cross Section Design of Inflatable Fabric in Expanded Position

A suitable system of elastomeric coatings for spray-on application was selected for coating the 3-D fabric casings. To obtain a reasonably good coated surface, eight successive coats of Neoprene-latex were required. A coat of white Hypalon was applied over the Neoprene-latex surface. This coat was followed by an olive green Hypalon as the top coat. A number of problems were encountered, particularly with the spraying equipment for the Neoprene-latex. The investigation led to airless spraying using a custom-built pressure accumulator with bladder. This set-up minimized latex coagulations.

BENEFITS

The project has resulted in a defined method of manufacturing integrally woven double-wall, air inflatable structures (see Figure 2 for finished shelter). An integrally woven (3-D) structure has high reliability due to the elimination of sewn and cemented seams at critical load bearing points. However, the weaving and coating techniques used in the manufacture of this type shelter are highly technical and costly.

IMPLEMENTATION

The introduction of an integrally woven inflatable MUST shelter as a replacement for the existing sewn and cemented type cannot be justified due to high cost. The integrally woven double-wall shelter is considered more

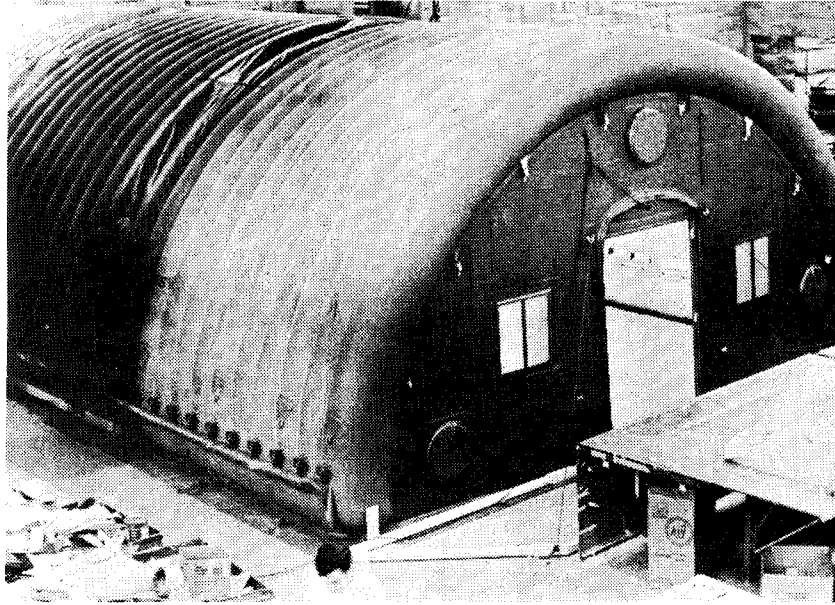

Figure 2 - Exterior of the MUST Shelter Unit - Manifold Side

suitable to large expansive structures such as an aircraft field maintenance hangers. Two inflatable sections with end panels were to be shipped to McDill Air Force Base, Tampa, FL, for user evaluation.

MORE INFORMATION

Additional information on this project is available from Mr. Frank Civilikas, Natick Laboratories, AV 955-2303 or Commercial (617) 653-2303.

Summary Report was prepared by James Bruen, Manufacturing Technology Division, US Army Industrial Base Engineering Activity, Rock Island, IL 61299.

MANUFACTURING METHODS AND TECHNOLOGY
PROJECT SUMMARY REPORT
(RCS DRCMT-302)

Manufacturing Methods and Technology Projects 774 3508 and 775 3508 titled, "Production of Dry Composite Membranes for Reverse Osmosis," were completed by the US Army Mobility Equipment Research and Development Command in April 1976 and September 1978 at costs of \$387,000 and 140,000, respectively.

BACKGROUND

The US Army has requirements for a family of multipurpose water purification equipment to produce potable water in the field from raw polluted fresh water, sea water, brackish water, and water contaminated with CBR materials. The process, based on the reverse osmosis (RO) principle, requires the use of a plastic permselective membrane. Commercial membranes available have only been the wet, one-component, anisotropic type. Unfortunately, the wet membrane introduces numerous operational, logistic, and maintenance problems peculiar to field military operations. The wet membrane cannot be dehydrated and, therefore, requires special complex handling in freezing, hot arid, and tropical environments. Most importantly, the water required to keep membranes wet supports growth of micro-organisms when in storage. Water adds significantly to the package weight, limiting the mobility of field units. A dry composite RO membrane is urgently needed for use in full scale water purification units. Laboratory studies have resulted in the development of a satisfactory technique for the making of a dry composite membrane.

SUMMARY

The objective of the project was to develop the machinery, manufacturing methods and techniques required for the quantity production of a wet/dry reversible RO membrane element for use in a military multipurpose RO water purification unit.

The first phase of the effort was directed to evaluating processing techniques and establishing equipment design for making dry composite membranes. Production equipment for continuous casting of dry cellulose acetate membranes and fabrication of spiral wound RO elements were built, 100 brackish water elements were delivered, and all specifications, drawings and manuals were delivered. Successful testing of 20 of the brackish water elements for 500 hours with natural brackish water at Roswell, NM, were carried out.

The second phase was directed to the fabrication and test of the prototype equipment for producing a dry composite membrane meeting military requirements and for the establishment of procurement documentation.

The final result of the MMT program was the development of a technical data package (drawings, specifications, manual, process data, etc.) and the

fabrication of cellulosic-type, all-purpose seawater reverse osmosis elements capable of being wet-dry cycled without deleterious effect on their performance. Figure 1 shows the membrane inspection stand.

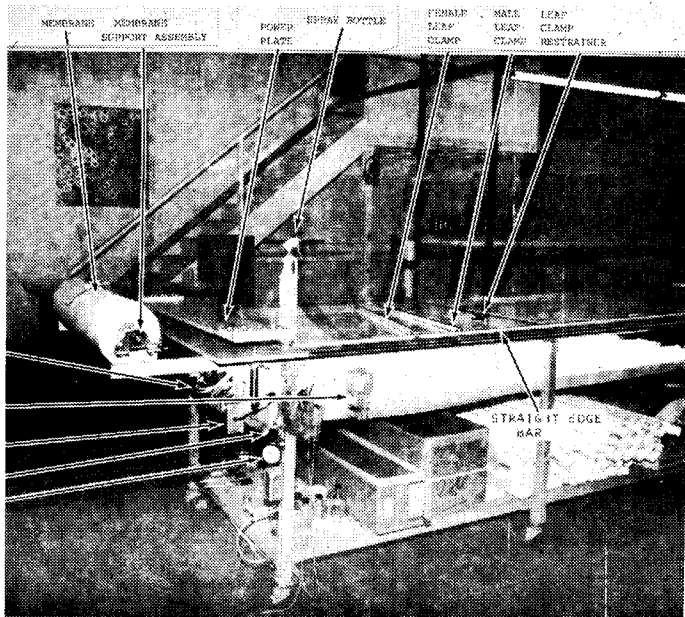

Figure 1 - Membrane Inspection Stand

BENEFITS

The program has resulted in the development of techniques and equipment for the quantity production of wet/dry reversible dry cellulosic-purification equipment. The program provided for the method of manufacture of wet/dry reversible RO membrane needed by the military but which was unavailable commercially.

IMPLEMENTATION

The RO membrane produced in this program was developed for use in the Army's multi-purpose RO water purification unit currently under development. The membrane is of the cellulosic, asymmetric type with a flux of about 5 gals/sq. ft/day and a salt rejection of 91% in operation with seawater. However, almost concurrent with the completion of the MMT program, a new, ultra thin, composite, polyamide-type membrane became commercially available. This polyamide membrane has properties superior to those of the MMT program-developed membrane. Its flux is about 10 gal/sq. ft/day and its salt rejection exceeds 98% in seawater operation. Because of these superior properties the polyamide membrane is being used in the fabrication of the elements for the Army's reverse osmosis water purification units.

MORE INFORMATION

Additional information can be obtained by contacting Mr. Maurice Pressman, MERADCOM, AV 354-5320 or Commercial (703) 664-5126.

Summary Report was prepared by W. R. Hierseman, Manufacturing Technology Division, US Army Industrial Base Engineering Activity, Rock Island, IL 61299.

MANUFACTURING METHODS AND TECHNOLOGY
PROJECT SUMMARY REPORT
(RCS DRCMT-302)

Manufacturing Methods and Technology Project 776 5504 titled, "Production of Phosphazene Elastomers" was completed by the US Army Troop Support and Aviation Materiel Readiness Command in July 1979 at a cost of \$250,000.

BACKGROUND

In the Arctic region, refueling operations must be conducted at temperatures as low as -70°F . Presently, there are no fuel resistant elastomers available that could be utilized for fuel hoses which would still function at such temperatures. An earlier effort, partially supported by MMT funds, showed that fuel hoses could be fabricated from a phosphonitrilic fluoroelastomer (PNF^R-LT). Laboratory tests indicated that the hose and rubber compounds of PNF^R-LT were sufficiently flexible at -70°F . However, the calendaring process used to make the hose and cover were not entirely satisfactory. The fuel hoses produced showed signs of blistering during Arctic fuel handling exercises during the winter of 1976-1977.

SUMMARY

The objective of the MMT project was to establish a large-scale manufacturing process. The project utilized an extrusion process for the tube and calendaring for the cover. These techniques are the usual large scale production methods for these types of items.

The initial phase of this work was to develop a PNF^R-LT compound which could be extruded and still maintain good low temperature properties. It was also desirable to maintain other properties such as fuel resistance, and adhesion to rayon. The best balance of properties was achieved with an FEF black compound in which the optimum level of black was about one-third. In order to achieve good extrusions, it was also necessary to heat age the polymer at 300°F for 8.5 hours. The resultant compound extruded very nicely and low temperature properties were good. Tensile strength and modulus did not meet specifications but were probably as high as possible for any PNF^R-LT compound that is extrudable and possesses good low temperature flexibility.

Manufacturing of the collapsible and suction type hoses proceeded well. The extrusion process produced excellent tube sections and greatly facilitated the entire production technique. There were some minor difficulties experienced in the calendaring of the very thin layer (0.014 inch) for collapsible hose and with possible pull down of fabric into the tube section. These problems could probably be easily remedied by modifying the specifications on thicknesses of tube and layer sections.

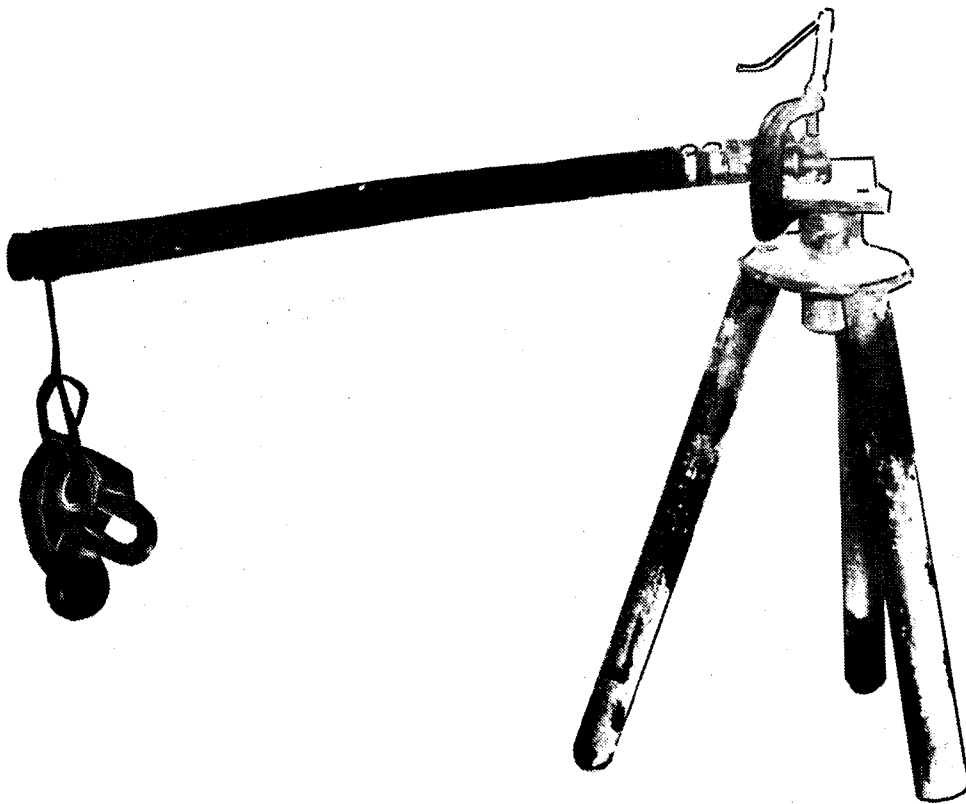

Figure 1 - Standard MIL-H-11588 Hose Remains Rigid At -70°F With 25 lbs. of Weight Attached To The Free End

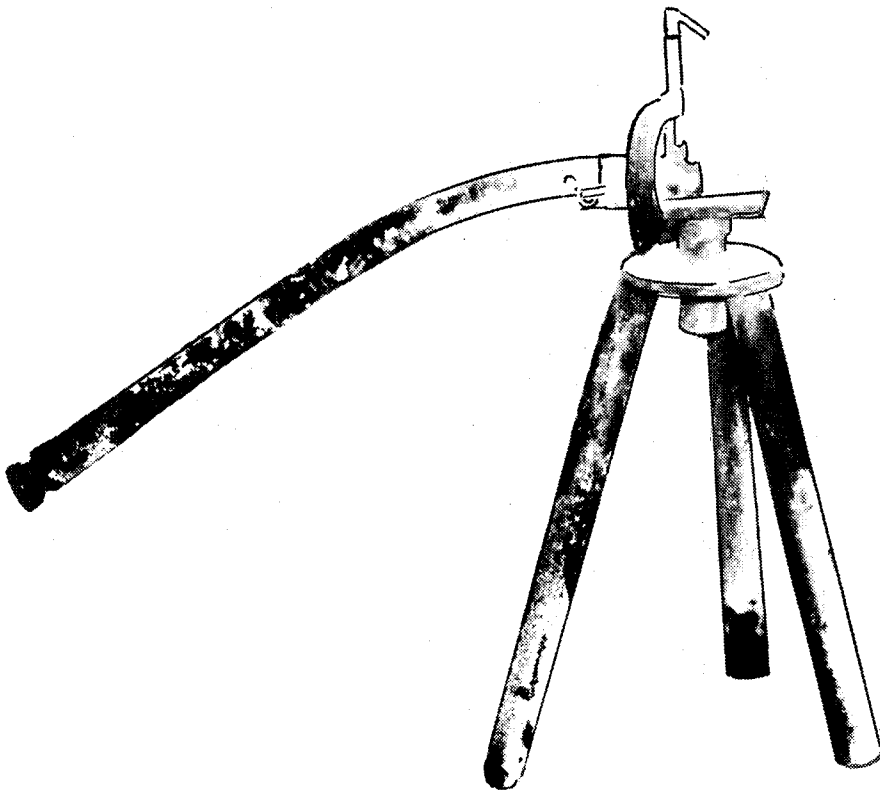

Figure 2 - The PNT-LT Polyphosphazene Hose Deflects Under Its Own Weight Even At -70°F

Other refinements in the hose fabrication technique were also made. A reduction in fabric content was made which resulted in increased strike-through of rubber. Although adhesion data could not be obtained, it appeared that improved bonding of tube to cover was achieved. The reduction in fabric also produced a more flexible hose. Another modification which may have contributed to improved bonding of various sections of hose was the addition of a coupling agent to the cement formulation. Gehman low temperature test procedures were carried out in the MERADCOM cold test chamber. Results show that the hoses are flexible at -70°F. (See Figures 1 and 2). The reduction in the amount of fabric in the hoses should enhance this flexibility.

The PNF^R-LT fuel hose with the extruded tube was tested in conjunction with other types of fuel hoses during winter exercises 1977-1978 at the Army Cold Regions Test Center, Ft. Greely, Alaska. However, the lack of sustained cold temperatures and fuel contamination problems (which were subsequently resolved) limited the scope of the Arctic testing. The blistering problem encountered in earlier tests was eliminated except for one section of discharge hose.

BENEFITS

Prior to this project, most commercial polymers were derived from petroleum. In contrast, polyphosphazenes are synthetic inorganic based polymers. Hence, large scale development of these materials could reduce the Army's dependence on oil. As work progressed, it became apparent that polyphosphazenes had potential for a variety of applications including O-rings, oilseals, bio-replacement materials (heart valves), fire-resistant cable coatings and flexible foams. The greatest technological impact is expected for flame retardant applications such as foams, wire coverings and paints. Most organic polymers either burn rapidly in air or evolve excessive amounts of smoke and toxic gases.

IMPLEMENTATION

Although the results were encouraging, more testing would be required before military specifications could be changed for hoses and gaskets. At about the time this project was completed, however, promising new materials for low temperature fuel hose operation became available commercially. It was decided to evaluate these before any further testing of the polyphosphazene materials is done.

The knowledge gained in this project, however, was utilized in another military application. The first commercial application based on polyphosphazene rubber is the 5.5 lb M-1 tank air plenum seal. It was chosen for its superior low temperature flexibility, flex fatigue resistance combined with excellent fluid and fuel resistance.

MORE INFORMATION

Additional information may be obtained from Dr. Robert Singler, AMMRC, AV 955-3147 or Commercial (617) 923-3147.

Summary Report was prepared by Wayne Hierseman, Manufacturing Technology Division, US Army Industrial Base Engineering Activity, Rock Island, IL 61299.

MANUFACTURING METHODS AND TECHNOLOGY
PROJECT SUMMARY REPORT
(RCS DRCMT-302)

Manufacturing Methods and Technology Project H78 9841 titled, "Zinc Selenide Windows and Optical Elements," was completed by the US Army Electronics Research and Development Command in June 1980 at a cost of \$156,444.

BACKGROUND

Night vision systems are used extensively by all three Services and incorporate elements for visible light intensification, infrared detection, and laser targeting. These elements operate in different parts of the optical spectrum and require aperture windows for protection. When conventional materials were employed, each element required a separate aperture, since the window material transmitted only a narrow bandwidth of light. The need to reduce cost by consolidating the optics behind a larger, single window demanded a material with a larger optical bandwidth. Such a window made of zinc selenide can transmit radiation from 0.5 to 14 microns--a large bandwidth--while providing necessary color correction. However, no production method existed for economically producing large quantities of zinc selenide lens blanks.

SUMMARY

The objective of this project was to reduce the production cost of zinc selenide windows by automation of existing methods. Raytheon Research Division, Waltham, MA, was awarded the contract on the basis of its 20-year experience with zinc selenide optics.

Optical blanks were prepared using chemical vapor deposition (CVD) in which vaporized compounds are allowed to thermally decompose onto a substrate and form a solid material. The CVD system employed by Raytheon included a 51-inch diameter high-capacity vacuum chamber with a zinc evaporating system, see Figure 1. The solid zinc is externally fed into the evaporation chamber in wire form, allowing accurate control of both the deposition rate and the desired zinc selenide stoichiometry. Zinc vapor is generated by heating the wire to a liquid state and evaporating it at reduced pressure. It is then carried by an inert gas to the deposition chamber and reacted with hydrogen selenide gas. Deposition occurs in a substrate box at a temperature of 750°C and a pressure of 40 torr.

A graphite box mandrel was used for the deposition substrate with nearly 400 concave lens sites available on the largest mandrel, see example in Figure 2. The site depressions were of varying size, with the largest being 75mm in diameter. Approximately 150 hours were needed for deposition of the required 13mm lens thickness, with an additional 30 hours for controlled

heat-up and cool-down operations. Cooled zinc selenide plates were then removed and the blanks separated with a diamond saw.

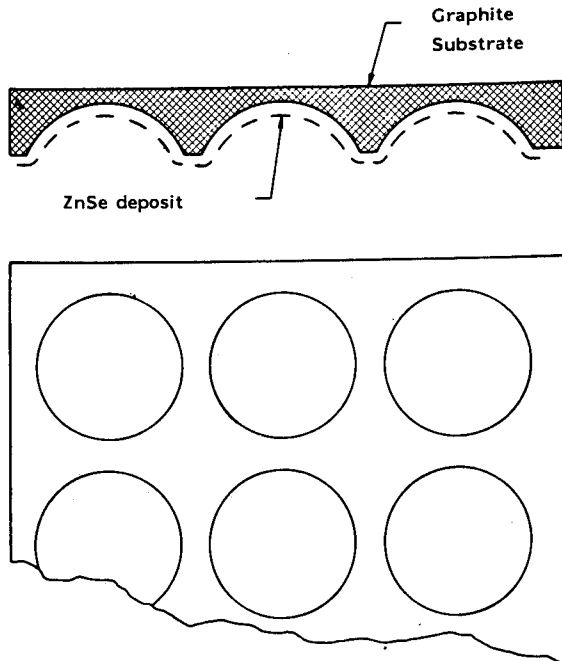

Figure 1 - Schematic Diagram of CVD ZnSe Furnace

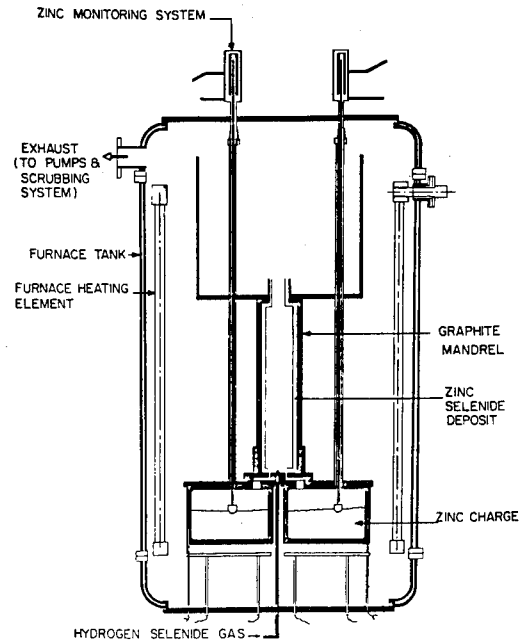

Figure 2 - Curved Mandrel

Yields for the pilot production were acceptably high, but approximately two percent were lost during lens cutting procedures. Twelve blanks from the pilot run were polished and subjected to numerous tests. Some of the optical tests were measurements for inclusions, transmittance over an 8 to 13 micron bandwidth, and angular scatter of a light beam. Mechanical tests included surface hardness, rupture modulus, permanent strain, and surface parallelism. The 12 samples met all the test requirements.

BENEFITS

The contract provided a fully automated process for production of zinc selenide optical elements which reduced production labor cost and waste in finishing the lens blanks. The windows fabricated were used for color correction in forward-looking infrared imagers. Cost reduction of \$65,000 was realized with the procurement of approximately 200 blanks for the XM1 program.

IMPLEMENTATION

The project was self-implementing as Raytheon is a prime supplier of zinc selenide for optical requirements. Presently, over 1000 optical blanks have been sold to subcontractors for use in forward-looking infrared sensors for all three Services. A final technical report was distributed to government agencies and industry.

MORE INFORMATION

Additional information may be obtained by contacting Mr. Robert A. Spande, Night Vision and Electro-Optics Laboratory, Ft. Belvoir, VA, AV 354-6665 or Commercial (703) 664-6665. The contract number was DAAB07-78-C-7038.

Summary Report was prepared by Charles Miller, Manufacturing Technology Division, US Army Industrial Base Engineering Activity, Rock Island, IL 61299.

MANUFACTURING METHODS AND TECHNOLOGY
PROJECT SUMMARY REPORT
(RCS DRCMT-302)

Manufacturing Methods and Technology Project R78 3150 titled, "Develop Methodology for Utilizing Ultraviolet Cured Conformal Coatings," was completed by the US Army Missile Command in August 1980 at a cost of \$126,000.

BACKGROUND

Conformal coatings used on printed circuit boards are two-part, catalyst cured plastic compounds. In order to obtain useful "pot life," the formulations require long curing periods at elevated temperature. This allows coatings to sag and pick up dust causing rejections. Other disadvantages such as use of poisonous solvents and the danger of incorrect mixing make existing conformal coatings expensive and hard to apply.

The finishing and printing industry use various coatings which have an ultra-violet curable resin base. These coatings have indefinite pot-life. They harden within seconds when flooded with ultraviolet which activates a photoactive catalyst. No heating is required for the cure. Application can be airless spray or curtain coating. Prior use was in mass-produced items such as plywood coating which involves flat surfaces only. A coating method for the complex surface of a printed circuit board is required. Enough preliminary work has been accomplished with these resins to indicate that some of these materials will pass MIL-l-46058 requirements.

SUMMARY

The purpose of this project was to develop a procedure to provide a qualified conformal coating which applies easily and cures within seconds instead of hours.

The majority of ultraviolet coating suppliers were contacted to obtain coating samples ready for direct application. These suppliers either submitted materials for testing or declined for various reasons.

Screening of candidate materials continued through June 1979. Approximately 30 candidate materials were screened during this period. Another five materials and modifications of two more were chosen for additional screening.

This total was reduced to three deemed most satisfactory to be subjected to MIL-l-46058 qualification testing. Three more were considered during later stages and passed their initial tests.

Material selection resulted in only one material, Hughson RD 3650-21, that met the objectives of a one-part system and passed MIL-l-46058 test requirements.

Three different application processes were considered and evaluated. The one finally selected and developed used spray coating and ultraviolet curing. However, in some cases, additional cure (conventional) was required to insure complete curing of the shadowed areas (areas beneath or adjacent to components that are shielded from the ultraviolet source). Hence, the Hughes SCG developed process shown in Figure 1 calls for spray application, ultraviolet cure, and oven post-cure (25 min. at 200°F).

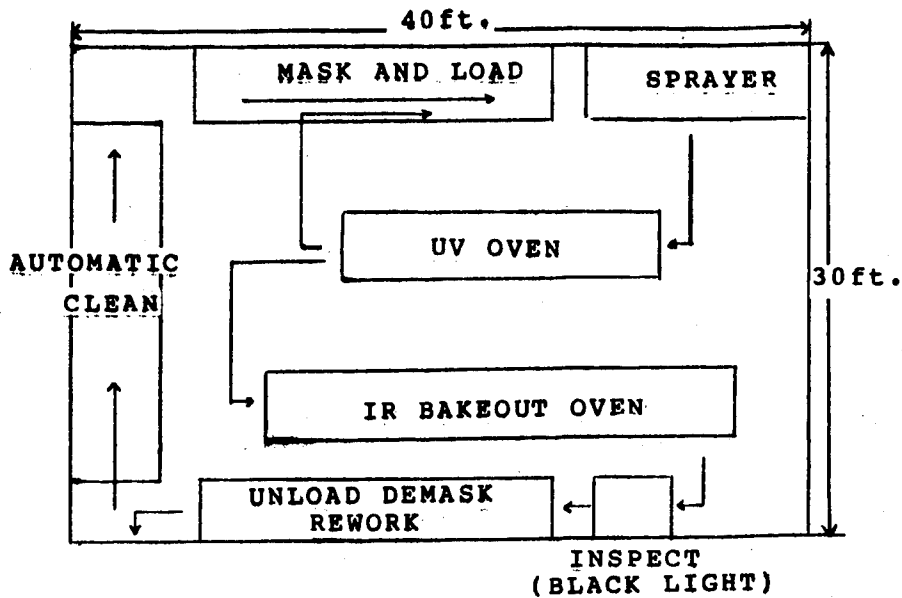

Figure 1 - Proposed UV PWB Coating Facility Layout

Two late arrival candidates, Grace XRCP 432C and DeSoto 2633-115-1 (+BP), have passed all the tests (cure, hydrolytic stability, flex insulation resistance and appearance.) Hence, they are also potential candidates for later full qualification testing.

BENEFITS

Ultraviolet cured conformal coating has the potential to save production costs if the material:

1. is a single component ready-to-apply system,
2. does not require the addition of solvents,
3. cures in seconds, including obscured areas.

The savings that occur are from the elimination of mixing and long curing periods.

IMPLEMENTATION

MIL-I-46058 requirements for conformal coatings have been changed to be performance oriented rather than specifying the type material to be applied. Hence, materials which can be cured by ultraviolet light are now permitted.

Hughes Aircraft Co. is extremely interested in implementing this technology in both their military and commercial work. They have not yet done so because of their concern for being able to do repair work on circuit boards after they have been cured with ultraviolet light. Because of their interest, however, they are carrying on the work of the MMT project at their own expense. Their goal is to find a new material which can be cured by ultraviolet, but results in a softer conformal coating more amenable to making repairs on finished boards.

MORE INFORMATION

Additional information on this project is available from Mr. Robert L. Brown, MICOM, AV 746-5742 or Commercial (205) 876-5742. Another contact is John R. Fay, Hughes Aircraft Company, Commercial (213) 648-9328. Report DAAK40-78-C-0272 titled, "Methodology for UV Cured Conformal Coating," dated June 1980 has been prepared on the subject.

Summary Report was prepared by Wayne R. Hierseman, Manufacturing Technology Division, US Army Industrial Base Engineering Activity, Rock Island, IL 61299.

APPENDIX I
ARMY MMT PROGRAM OFFICES

ARMY MMT PROGRAM REPRESENTATIVES

HQ, DARCOM

US Army Materiel Development and Readiness Command

ATTN: DRCMT

5001 Eisenhower Avenue

Alexandria, VA 22333

C: 202 274-8284/8298

AV: 284-8284/8298

IBEA

US Army Industrial Base Engineering Activity

ATTN: DRXIB-M, Mr. James Carstens

Rock Island, IL 61299

C: 309 794-5113

AV: 793-5113

AVRADCOM

US Army Aviation R&D Command

ATTN: DRDAV-EGX, Mr. Dan Haugan

4300 Goodfellow Blvd

St. Louis, MO 63120

C: 314 263-1625

AV: 693-1625

CECOM

US Army Communications & Electronics Command

ATTN: DRSEL-POD-P-G, Messr Feddeler/Esposito/Resnic

ATTN: DRSEL-LE-RI, Mr. Leon Field

Fort Monmouth, NJ 07703

C: 201 535-4926

AV: 995-4926

C: 201 532-4035

AV: 992-4035

ERADCOM

US Army Electronics R&D Command

ATTN: DELET-R. Mr. Joseph Key

Fort Monmouth, NJ 07703

C: 201 544-4258

AV: 995-4258

MICOM

US Army Missile Command

ATTN: DRSMI-RST, Mr. Richard Kotler

Redstone Arsenal, AL 35809

C: 205 876-2065

AV: 746-2065

TACOM

US Army Tank-Automotive Command

ATTN: DRSTA-RCKM, Dr. Jim Chevalier

Warren, MI 48090

C: 313 573-6065/5814/6467

AV: 786-6065/5814/6467

ARRCOM

US Army Armament Materiel Readiness Command

ATTN: DRSAR-IRI-A, Mr. Dennis Dunlap

Rock Island Arsenal

Rock Island, IL 61299

C: 309 794-4485/5446

AV: 793-4485/5446

ARRADCOM

US Army Armament R&D Command

ATTN: DRDAR-PML, Mr. Donald J. Fischer

Dover, NJ 07801

C: 201 328-2708

AV: 880-2708

TSARCOM

US Army Troop Support and Aviation Materiel Readiness Command

ATTN: DRSTS-PLE, Mr. Don G. Doll

4300 Goodfellow Bldg

St. Louis, MO 63120

C: 314 263-3040

AV: 693-3040

MERADCOM

US Army Mobility Equipment R&D Command

ATTN: DRDME-UE, Mr. R. Goehner

Fort Belvoir, VA 22060

C: 703 664-4221

AV: 354-4221

NLABS

US Army Natick R&D Laboratories

ATTN: DRDNA-EZM, Mr. Frank Civilikas

Natick, MA 01760

C: 617 653-1000, X2793

AV: 955-2349/2351

TECOM

US Army Test and Evaluation Command

ATTN: DRSTE-AD-M, Mr. Grover Shelton

Aberdeen Proving Ground, MD 21005

C: 301 278-3677

AV: 283-3677

AMMRC

US Army Materials & Mechanics Research Center

ATTN: DRXMR-PMT, Mr. Raymond Farrow

Watertown, MA 02172

C: 617 923-3523

AV: 955-3523

HDL

Harry Diamond Laboratories

ATTN: DELHD-PO, Mr. Julius Hoke

2800 Powder Mill Road

Adelphi, MD 20783

C: 202 394-1551

AV: 290-1551

Rock Island Arsenal

ATTN: SARRI-EN, Mr. Walt Kisner

Rock Island, IL 61299

C: 309 794-5581

AV: 793-5581

Watervliet Arsenal

ATTN: SARWV-PPI, Mr. T. Wright

Watervliet, NY 12189

C: 518 266-5319

AV: 974-5319

US Army Munitions Production Base Modernization Agency

ATTN: SARPM-PBM-DP, Mr. Joseph Taglairino

Dover, NJ 07801

C: 201 328-6708

AV: 880-6708

AMRDL

US Army Applied Technology Laboratory

USARTL (AVRADCOM)

ATTN: SAVDL-EU-TAS, Mr. L. Thomas Mazza

Fort Eustis, VA 23604

C: 804-878-5732

AV: 927-5732

DESCOM

US Army Depot System Command

ATTN: DRSDS-PE, Mr. Jim Shindle

Chambersburg, PA 17201

C: 717 263-6321

AV: 242-6321

APPENDIX II
DISTRIBUTION

DRXIB-MT
DISTRIBUTION:

Department of Defense:

OUSDRE (R&AT), The Pentagon, Attn: Dr. Lloyd L. Lehn (2 cys)
DIRSO, Attn: Mr. Burton Bartsch

Department of the Army:

HQDA, OASARDA, The Pentagon, Attn: Mr. William Takakoshi
HQDA, ODCSRDA, The Pentagon, Attn: DAMA-PPM-P, Mr. Rod Vawter
DCSRDA, Attn: DAMA-WSA, LTC Jay B. Bisbey
DCSRDA, Attn: DAMA-WSM-A, Mr. John Doyle
DCSRDA, Attn: DAMA-WSW, MAJ Gordon Winder
DCSRDA, Attn: DAMA-CSC-BU, COL Higgins
DCSRDA, Attn: DAMA-CSS-P, LTC L. R. Hawkins, LTC P. K. Linscott
DCSRDA, Attn: DAMA-CSM-P, Mr. John Mytryshyn
DCSRDA, Attn: DAMA-CSM-DA, COL Jack King

HQ DARCOM:

Cdr, DARCOM, Attn: DRCCG
Cdr, DARCOM, Attn: DRCDMD
Cdr, DARCOM, Attn: DRCDMR
Cdr, DARCOM, Attn: DRCP
Cdr, DARCOM, Attn: DRCP-I (3 cys)
Cdr, DARCOM, Attn: DRCDE
Cdr, DARCOM, Attn: DRCMT (20 cys)
Technical Library, Attn: DRXAM-TL

AVRADCOM:

PM, Advanced Attack Helicopter, Attn: DRCPM-AAH
PM, Blackhawk, Attn: DRCPM-BH
PM, CH-47, Mod. Program, Attn: DRCPM-CH47M
Cdr, Attn: DRDAV
Cdr, Attn: DRDAV-EGX, Mr. Dan Haugan
Technical Library, St. Louis, MO
Technical Library, Air Mobility R&D Lab, Ft. Eustis, VA
Cdr, AMRDL, Attn: SAVDL-EU-TAS, Mr. L. Thomas Mazza (3 cys)

ARRADCOM:

PM, Cannon Artillery Weapons Systems, Attn: DRCPM-CAWS
PM, Division Air Defense (DIVAD) Gun, Attn: DRCPM-ADG
PM, Nuclear Munitions, Attn: DRCPM-NUC
PM, Selected Ammunition, Attn: DRCPM-SA
Cdr, Attn: DRDAR
Cdr, Attn: DRDAR-PMP-P, Mr. Donald J. Fischer (7 cys)
Cdr, Benet Wpns Lab, Attn: DRDAR-LCB-S, Dr. F. Heiser (3 cys)
Cdr, Attn: DRDAR-QAR, I, Mr. Mark Weinberg
Chemical Systems Lab, Technical Library, Attn: DRDAR-CLY-T

DRXIB-MT
DISTRIBUTION (Cont'd):

Aberdeen Proving Ground:

PM, Chemical Demilitarization & Installation Restoration, Attn: DRCPM-DR
PM, Smoke/Obscurants (SMOKE), Attn: DRCPM-SMK
Cdr, Attn: STEAP-MT-M, Mr. J. L. Sanders
Cdr, US Army Toxic & Hazardous Materials Agency, Attn: DRXTH-TE-D

ARRCOM:

PM, M110E2 Weapon System, Attn: DRSAR-HA
Cdr, Attn: DRSAR-CG
Cdr, Attn: DRSAR-IRB, Mr. Dennis Dunlap (2 cys)
Cdr, Attn: DRSAR-IRW, Mr. Arne Madsen
Cdr, Attn: DRSAR-LEP, Mr. Bolton (6 cys)
Technical Library, Attn: DRSAR-LEP-L (14 cys)

AMMRC:

Dir, Attn: DRXMR-PT, Mr. Raymond Farrow
Dir, Attn: DRXMR-EO, Dr. Morton Kliman
Dir, Attn: DRXMR, DRXMR-M (1 cy ea)

CECOM:

Cdr, Attn: DRSEL
Cdr, Attn: DRSEL-LE-RI, Mr. Leon Field
Cdr, Attn: DRSEL-POD-P-G, Messrs. Feddeler, Esposito, Resnic (1 cy ea)
PM, Signal Intelligence/Electronic Warfare (SIGINT/EW), Attn: DRCPM-SIEW
PM, Army Tactical Communications Systems (ATACS), Attn: DRCPM-ATC
PM, Automatic Test Support Systems, Attn: DRCPM-ATSS
RD&E Technical Documents Ctr, Ft. Monmouth, NJ

DESCOM:

Cdr, Attn: DRSDS
Cdr, Attn: DRSDS-PE, Mr. Jim Shindle (2 cys)

ERADCOM:

PM, FIREFINDER/REMBASS, Attn: DRCPM-FFR
PM, Stand-off Target Acquisition System, Attn: DRCPM-STA
Cdr, Attn: DRDEL
Cdr, Attn: DELET-R, Messrs Key, Reich (2 cys ea)
Cdr, Attn: DRDEL-ED, Mr. Harold Garson
Cdr, Attn: DELEW-PE, Messrs Bohnert, Kelly (1 cy ea)

MERADCOM:

PM, Mobile Electric Power, Attn: DRCPM-MEP (Springfield, VA)
Cdr, Attn: DRDME
Cdr, Attn: DRDME-UE, Mr. R. Goehner (9 cys)
Technical Library, Ft. Belvoir, VA

DRXIB-MT
DISTRIBUTION (Cont'd):

MICOM:

PM, Multiple Launch Rocket System, Attn: DRCPM-RS
PM, Ground Laser Designators, Attn: DRCPM-LD
PM, HAWK, Attn: DRCPM-HA
PM, Heliborne Laser Fire and Forget (HELLFIRE) Missile System,
Attn: DRCPM-HE
PM, High Energy Laser System, Attn: DRCPM-HEL
PM, PATRIOT, Attn: DRCPM-MD
PM, 2.75 Rocket System, Attn: DRCPM-RK
PM, STINGER, Attn: DRCPM-MP
PM, TOW-DRAGON, Attn: DRCPM-DT
PM, US ROLAND, Attn: DRCPM-ROL
PM, VIPER, Attn: DRCPM-VI
Cdr, Attn: DRSMI
Cdr, Attn: DRCMI-RST, Mr. Bob Austin, Mr. Richard Kotler
Magazine Room, Attn: RSIC

NARADCOM:

Cdr, Attn: DRDNA
Cdr, Attn: DRDNA-EZM, Mr. Frank Civilikas
Technical Library, Attn: DRXTM-TRL

TACOM:

PM Armored Combat Vehicle Technology (ACVT), Attn: DRCPM-CVT
PM, Fighting Vehicle Armament, Attn: DRCPM-FVA
PM, Fighting Vehicle Systems, Attn: DRCPM-FVS
PM, Heavy Equipment Transporter (HET), Attn: DRCPM-HT
PM, Improved TOW Vehicle, Attn: DRCPM-ITV
PM, XM-1 Tank System, Attn: DRCPM-GCM
Cdr, Attn: DRSTA
Cdr, Attn: DRSTA-EB, Ms Vivian Buarkhalter
Cdr, Attn: DRSTA-RCKM, Dr. J. Chevalier
Technical Library, Warren, MI

TECOM:

Cdr, Attn: DRSTE
Cdr, Attn: DRSTE-AD-M, Mr. Grover Shelton (3 cys)
Tech Library, Dugway Proving Grounds, UT
Tech Library, White Sands Missile Range, Attn: STEWS-PT-AL
Tech Library, Yuma, AZ

TSARCOM:

PM, COBRA, Attn: DRCPM-CO
Cdr, Attn: DRSTS
Cdr, Attn: DRSTS-PLE, Mr. Don G. Doll (3 cys)

DRXIB-MT
DISTRIBUTION (Cont'd):

Arsenals:

Cdr, Pine Bluff Arsenal (PBA), Attn: SARPB-CO (6 cys)
Cdr, Rocky Mountain Arsenal (RMA), Attn: SARRM-IS
Cdr, Rock Island Arsenal (RIA), Attn: SARRI-CO (6 cys)
Cdr, RIA, Attn: SARRI-ENM, Mr. Joseph DiBenedetto (3 cys)
Cdr, Watervliet Arsenal (WVA), Attn: SARWV-CO (6 cys)
Cdr, WVA, Attn: SARWV-PPI, Mr. T. Wright (3 cys)
Cdr, Benet Wpns Laboratory, Attn: DRDAR-LCB-TL, Tech Library, Watervliet, NY

Munitions Production Base Modernization Agency:

Cdr, MPBMA, Attn: SARPM-PBM-DP, Mr. Joseph Taglairino (5 cys)

Army Ammo Plants: (2 cys ea)

Cdr, Crane AAA, Attn: SARCN
Cdr, Crane AAA, Attn: SARCN-QAM6, Mr. S. R. Caswell
Cdr, Hawthorne AAP, Attn: SARHW-CO
Cdr, Holston AAP, Attn: SARHO-CO
Cdr, Indiana AAP, Attn: SARIN-CO
Cdr, Iowa AAP, Attn: SARIO-CO
Cdr, Kansas AAP, Attn: SARKA-CO
Cdr, Lake City AAP, Attn: SARLC-CO
Cdr, Lone Star AAP, Attn: SARLS-CO
Cdr, Longhorn AAP, Attn: SARLO-CO
Cdr, Louisiana AAP, Attn: SARLA-CO
Cdr, McAlester AAP, Attn: SARMC-FD
Cdr, Milan AAP, Attn: SARMI-CO
Cdr, Mississippi AAP, Attn: SARMS
Cdr, Radford AAP, Attn: SARRA-CO
Cdr, Riverbank AAP, Attn: SARRB-CO
Cdr, Scranton AAP, Attn: SARSC-CO
Cdr, Army Weapons Support Ctr, Crane, IN 47522

Depots: (3 cys ea)

Cdr, Anniston Army Depot, Attn: SDSAN-MD
Cdr, Corpus Christi Army Depot, Attn: SDSCC-MPI
Cdr, Letterkenny Army Depot, Attn: SDSLE-MM
Cdr, Letterkenny Army Depot, Attn: SDSLE-MM, Mr. Michael Baccellieri
Cdr, New Cumberland Army Depot, Attn: SDSNC-ME
Cdr, Red River Army Depot, Attn: SDSRR-MO
Cdr, Sacramento Army Depot, Attn: SDSSA-MPE
Cdr, Seneca Army Depot, Attn: SDSSE-OP
Cdr, Sharpe Army Depot, Attn: SDSSH-R
Cdr, Sierra Army Depot, Attn: SDSSI-EM
Cdr, Tobyhanna Army Depot, Attn: SDSTO-M
Cdr, Tooele Army Depot, Attn: SDSTE-MAN
Tech Library, Tobyhanna, PA

DRXIB-MT

DISTRIBUTION (Cont'd):

Army Organizations:

Cdr, Army Logistics Management Ctr, (ALMC), Attn: DRXMD
Cdr, Army Research Office (ARO), Attn: DRXRO-AO
Cdr, Army Ballistic Research Labs (BRL), Attn: DRDAR-BL
Cdr, HDL, Attn: DELHD-PO, Mr. Julius Hoke (3 cys)
Cdr, Harry Diamond Labs, Attn: DELHD-CO (6 cys)
Cdr, Ballistic Research Lab, Attn: DRXBR-TSB-S
Cdr, Foreign Science and Technology Ctr (FSTC), Attn: DRXST-MT1,
Mr. James Wamsley (2 cys)
Dir, Installations and Services Activity (I&SA), Attn: DRCIS-RI
Dir, Army Management Engineering Training Acty (AMETA), Attn: DRXOM-SE,
Dr. Shallman (3 cys)
Cdr, Night Vision Labs (VNL), Attn: DRSEL-NV-PA/IO
Plastics Technical Evaluation Ctr., Attn: Harry Peibly
Dir, DARCOM Intern Training Ctr., Attn: DRXMC-ITC-E, Mr. Carter
Metals & Ceramics Info Center, Attn: Mr. Del Spalsbury, Battelle,
Columbus Labs, Columbus, OH

Navy Organizations: (2 cys ea)

Cdr, NAVMAT, Attn: Mr. J. W. McInnis, Code 064
Cdr, NAVSEA, Attn: T. E. Draschil, Code C-05R23
Cdr, NAVAIR, Attn: Mr. R. A. Retta, Code AIR5162C
Cdr, NAVELEX, Attn: C. A. Rigdon, Code ELEX-504512
Cdr, Naval Surface Wpns Ctr/White Oak Lab, Attn: Code E345, Mr. Chas McFann
Cdr, Naval Surface Wpns Ctr/Dahlgren Lab, Attn: Code CM-51
Cdr, Naval Weapons Ctr, Attn: Code 36404
Cdr, Naval Weapons Center, Attn: C. Johnson, Code 3624
Dir, NMCIRD, Bldg 75-2, Naval Base
Cdr, Naval Ship Systems Engrg Station, Attn: 035.1 (1 cy)
Cdr, Naval Surf Wpns Ctr/Dahlgren, Attn: Dr. J.R. Thompson, Jr. (1cy)

Air Force:

Cdr, HQ, USAF/RDCM, The Pentagon, Attn: MAJ E. Ross
Cdr, AFSC/DLF, Andrew AFB
Cdr, AFSC/PPD, Andrew AFB
Cdr, AFML/LT, WPAFB
Cdr, AFML/LTE, /LTM, /LTN, WPAFB (1 cy ea)
Cdr, AFWAL/MLSS, WPAFB
Cdr, San Antonio Air Logistics Ctr, Kelly AFB, Attn: B. Boisvert, MMEI
Cdr, Hanscom AFB, Attn: AFGL-SULL, R. Bergmann

DRXIB-MT
DISTRIBUTION (Cont'd)

Professional Societies: (5 cys each)

Electronic Industrial Association (40 cys)

Attn: Mr. Jean Caffiaux, 2001 I St., N.W., Washington, DC 20006

Numerical Control Society (3 cys)

Attn: Mr. Ronald C. Hunt, Exec. Dir., 519-520 Zenith Dr.,
Glenview, IL 60025

Aerospace Industries Association

Attn: Mr. Robert Worthen, Col., US Army (Ret), 1725 Desales
Street, N.W., Washington, DC 20036

American Defense Preparedness Association

Attn: Mr. Rudolph Rose, Col., US Army (Ret), Rosslyn Ctr, Suite 900,
1700 N. Moore Street, Arlington, VA 22209

American Institute of Industrial Engineers

Attn: Mr. Mikell Groover, Packard Lab #19, Lehigh University,
Bethlehem, PA 18015

American Society for Testing and Materials

Attn: Mr. Samuel F. Etris, Special Assistant, 1916 Race Street,
Philadelphia, PA 19103

Cast Metal Federation

Attn: Mr. William E. Gephardt, Chairman, Govt. Supply Committee,
4870 Packard Road, Niagara Falls, NY 14304

Forging Industry Association (32 cys)

Attn: Mr. C. G. Scofield, Room 1121, 55 Public Square,
Cleveland, OH 44113

Society of Manufacturing Engineers

Attn: Mr. Bernard Sallot, One SME Drive, P.O. Box 930,
Dearborn, MI 48128

Metcut Research Associates, Inc. (1 cy)

Attn: Mr. John F. Kahles, 3980 Rosslyn Drive, Cincinnati, OH 45209