

PL-TR-95-2144

## SPACE SYSTEMS ENVIRONMENTAL INTERACTION STUDIES

M. Alvin Morgan  
Alan C. Huber  
John O. McGarity  
David J. Sperry  
Scott J. Moran  
John A. Pantazis

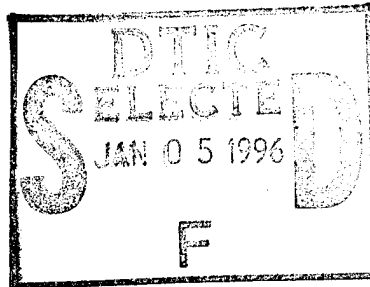

AMPTEK, INC.  
6 De Angelo Drive  
Bedford, Massachusetts 01730-2204

30 August 1995

19960103 128

Scientific Report No. 4

APPROVED FOR PUBLIC RELEASE; DISTRIBUTION UNLIMITED



**PHILLIPS LABORATORY**  
**Directorate of Geophysics**  
**AIR FORCE MATERIEL COMMAND**  
**HANSCOM AIR FORCE BASE, MA 01731-3010**

"This technical report has been reviewed and is approved for publication"

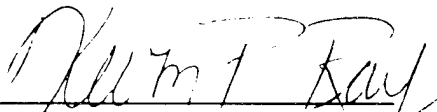

KEVIN P. RAY, Capt, USAF  
Contract Manager  
Space Particles Env. Branch  
Space Physics Division

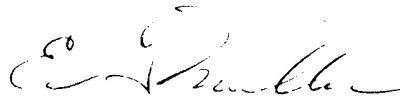

EDWARD G. MULLEN, Chief  
Space Particles Env. Branch  
Space Physics Division

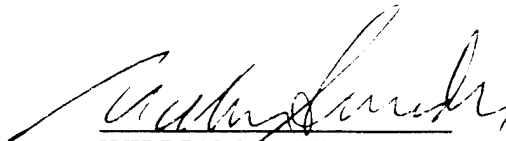

WILLIAM SWIDER  
Deputy Director  
Space Physics Division

This report has been reviewed by the ESC Public Affairs Office (PA) and is releasable to the National Technical Information Service (NTIS).

Qualified requestors may obtain additional copies from the Defense Technical Information Center. All others should apply to the National Technical Information Service.

If your address has changed, or if you wish to be removed from the mailing list, or if the addressee is no longer employed by your organization, please notify PL/TSI, 29 Randolph Road, Hanscom AFB, MA 01731-3010. This will assist us in maintaining a current mailing list.

Do not return copies of this report unless contractual obligations or notices on a specific document requires that it be returned.

# REPORT DOCUMENTATION PAGE

Form Approved  
OMB No. 0704-0188

Public reporting burden for this collection of information is estimated to average 1 hour per response, including the time for reviewing instructions, searching existing data sources, gathering and maintaining the data needed, and completing and reviewing the collection of information. Send comments regarding this burden estimate or any other aspect of this collection of information, including suggestions for reducing this burden, to Washington Headquarters Services, Directorate for Information Operations and Reports, 1215 Jefferson Davis Highway, Suite 1204, Arlington, VA 22202-4302, and to the Office of Management and Budget, Paperwork Reduction Project (0704-0188), Washington, DC 20503.

|   |  |   |                           |
|---|--|---|---------------------------|
| 1. AGENCY USE ONLY (Leave blank)  | 2. REPORT DATE<br>30 August 1995                           | 3. REPORT TYPE AND DATES COVERED<br>Scientific No. 4  |                           |
| 4. TITLE AND SUBTITLE<br><br>Space Systems Environmental Interaction Studies  |  | 5. FUNDING NUMBERS<br><br>PE 63410F<br>PR 2822 TA 01 WU AM<br><br>Contract F19628-91-C-0112 |                           |
| 6. AUTHOR(S)<br>M. Alvin Morgan                      David J. Sperry<br>Alan C. Huber                         Scott J. Moran<br>John O. McGarity                     John A. Pantazis   |  | 8. PERFORMING ORGANIZATION<br>REPORT NUMBER   |                           |
| 7. PERFORMING ORGANIZATION NAME(S) AND ADDRESS(ES)<br>AMPTEK, Inc.<br>6 De Angelo Drive<br>Bedford, MA 01730  |  | 10. SPONSORING / MONITORING<br>AGENCY REPORT NUMBER<br><br>PL-TR-95-2144                    |                           |
| 9. SPONSORING / MONITORING AGENCY NAME(S) AND ADDRESS(ES)<br>Phillips Laboratory<br>29 Randolph Road<br>Hanscom AFB, MA 01731-3010<br><br>Contract Manager: Kevin Ray, Capt., USAF/GPSP   |  | 11. SUPPLEMENTARY NOTES   |                           |
| 12a. DISTRIBUTION / AVAILABILITY STATEMENT<br><br>Approved for public release;<br>distribution unlimited.   |  | 12b. DISTRIBUTION CODE  |                           |
| 13. ABSTRACT (Maximum 200 words)<br><br>The effort expended on Task 1 (the Photovoltaic Array Space Power Plus Diagnostics [PASP Plus] experiment) during the report period, went into on-orbit support for the mission. Amptek, Inc. was called upon to assist in understanding some anomalous behavior in an instrument's performance. On Task 2, the Charging Hazards and Wake Studies (CHAWS) program, the Digital Ion Drift Meter (DIDM) instrument design and build process got underway. Company personnel also supported PL/GPSG at several meetings which were held to discuss spacecraft systems and/or instrument design issues. In addition, the preparation of SPREE hardware for the upcoming re-flight continued. This effort is now almost at an end. Under Task 3, (the Space Wave Interactions with Plasmas Experiment (SWIPE) the hardware was subjected to flight environmental tests, which was successfully concluded, and then delivered to PL/GPSG. System integration testing at the payload integrator's facility was supported by company personnel. |  |   |                           |
| 14. SUBJECT TERMS<br>Photovoltaic Array Space Power Plus Diagnostics, PASP Plus,<br>Charge Hazards and Wake Studies, CHAWS, Space Wave<br>Interactions with Plasmas Experiment, SWIPE, OEDIPUS-C  |  |   | 15. NUMBER OF PAGES<br>14 |
| 17. SECURITY CLASSIFICATION<br>OF REPORT<br>Unclassified  |  |   | 16. PRICE CODE            |
| 17. SECURITY CLASSIFICATION<br>OF THIS PAGE<br>Unclassified   | 18. SECURITY CLASSIFICATION<br>OF ABSTRACT<br>Unclassified | 20. LIMITATION OF ABSTRACT<br><br>SAR   |                           |

**CONTENTS**

|    |   |   |
|----|---|---|
| 1. | INTRODUCTION                                  | 1 |
| 2. | TASK #1 - PASP Plus EFFORTS                   | 1 |
|    | 2.1 Summary of Activities                     |   |
| 3. | TASK #2 - CHAWS EFFORTS                       | 4 |
|    | 3.1 Summary of Activities                     | 4 |
|    | 3.2 DIDM Activities                           | 4 |
|    | 3.3 SPREE Activities                          | 5 |
|    | 3.3.1 Rotary Table Motor Drives (RTMD's)      | 5 |
|    | 3.3.2 ElectroStatic Analyzers A and B (ESA's) | 6 |
|    | 3.3.3 Data Processor Unit (DPU)               | 6 |
|    | 3.3.4 Flight Data Recorders (FDR's)           | 6 |
|    | 3.3.5 Miscellaneous                           | 6 |
| 4. | TASK #3 - OEDIPUS-C EFFORTS                   | 7 |
|    | 4.1 Summary of Activities                     | 7 |
|    | 4.2 Software Functionality Verification       | 7 |
|    | 4.3 Environmental Testing                     | 8 |
|    | 4.4 End-to-End Functionality Testing          | 9 |

|                    |                                     |
|--------------------|-------------------------------------|
| Accession For      |                                     |
| NTIS CRA&I         | <input checked="" type="checkbox"/> |
| DTIC TAB           | <input type="checkbox"/>            |
| Unannounced        | <input type="checkbox"/>            |
| Justification      |                                     |
| By _____           |                                     |
| Distribution/      |                                     |
| Availability Codes |                                     |
| Dist               | Avail and/or Special                |
| A-1                |                                     |

## List of Figures

| <b>Number</b> |  | <b>Page</b> |
|---------------|--|-------------|
| 1:            | Nominal ESA Output Data from 10/25/94 .....                              | 1           |
| 2:            | ESA Output Showing Loss of Low Energy Ion Data.....                      | 2           |
| 3:            | ESA Output Showing Partial Return Of Low Energy Ion Spectra.....         | 3           |
| 4:            | ESA Output Showing Full Return Of Low Energy Ion Spectra on 6/19/95..... | 3           |
| 5:            | EPI Electronics Module Test Setup .....                                  | 7           |
| 6:            | EPI GSE Telemetry Interface Box (GSE TIB) Schematic .....                | 8           |
| 7:            | EPI GSE Instrument Status Display Screen.....                            | 9           |

## 1.0 INTRODUCTION

This contract's objective is to investigate spacecraft-environment interaction and space-plasma dynamics issues, especially as they relate to differential charging, discharge mechanisms, coupling between plasmas and space power systems, wake formation mechanisms, EM wave-particle interactions, and long-term radiation effects on operating systems in space.

The work is to be accomplished in three distinct *in-situ* investigation programs (identified as Task #'s (1), (2) and (3) and the completion of a data analysis and presentation period. Significant efforts were expended on Task #1 and Task #3 during the report period, with somewhat less being carried out on Task #2. Those efforts are detailed here. The material is presented in serial order, with issues relating to Task #1 discussed first in Section 2.

## 2.0 TASK #1—PASP Plus EFFORTS

### 2.1 Summary of Activities

With the APEX satellite now launched, support for PASP Plus on-orbit activities were provided by Amptek, Inc., and in this regard the company was called upon to assist in the understanding of some anomalous events during the report period. Prominent among these was the observance a few months after launch, of the fact that the low energy ion channel in the PASP Plus ElectroStatic Analyzer (ESA) had in effect, stopped working. As all indications were that the instrument was functioning nominally prior to the discovery, the question of what happened was immediately raised. The available data encompassing the time period immediately prior to and after the failure point, was examined at Amptek, where it was determined that output from a particular instrument channel (that measuring ions ranging in energy from 30 eV to 1 KeV-the low energy ion channel) went from a state of being fully functional, to one of virtually no output, over the course of two days. ESA data before and after the failure are shown in Figure 1 and Figure 2. These are nominal color plots, shown here in monochrome, to illustrate the variation in output spectra from the instrument only.

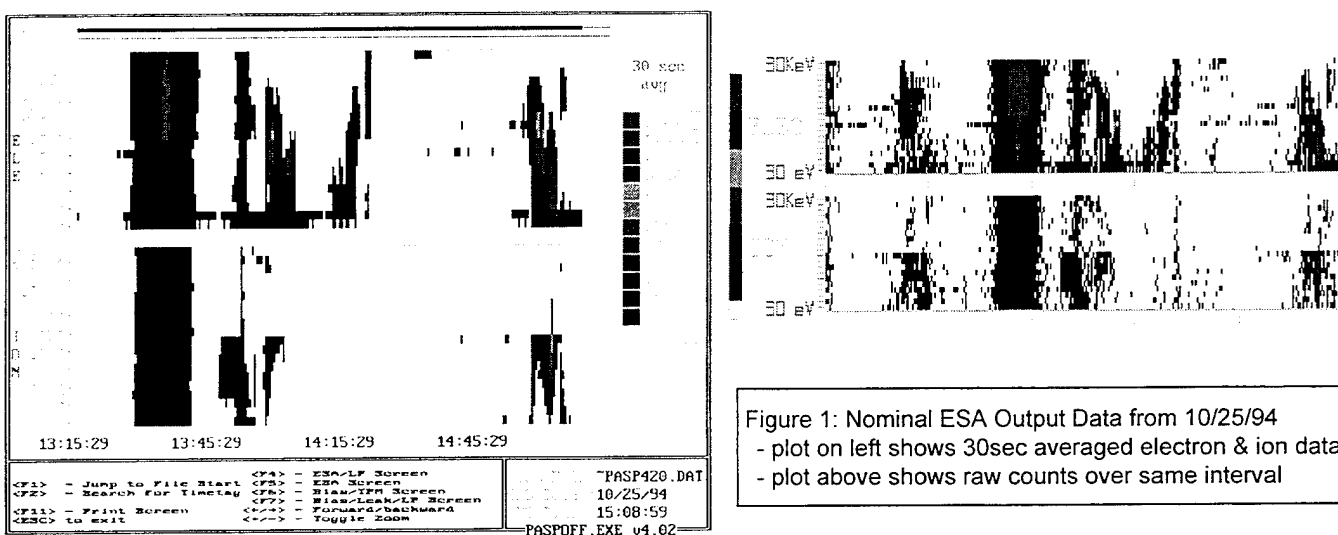

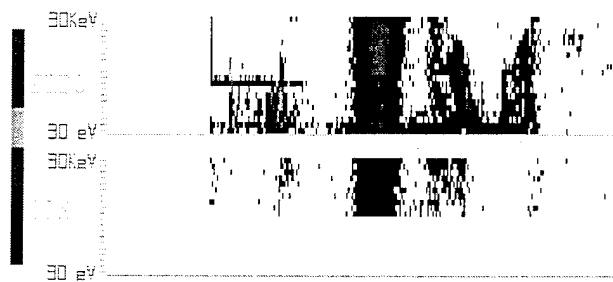
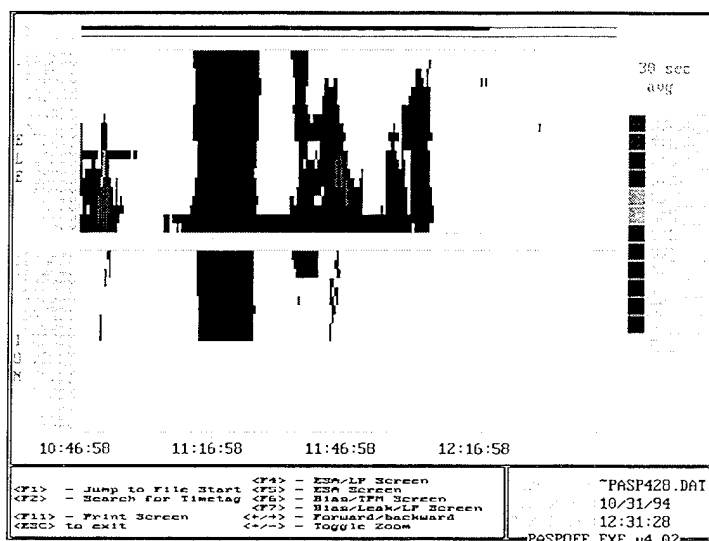

Figure 2: ESA Output showing loss of Low Energy Ion Data  
 - plot on left shows 30sec averaged electron & ion data  
 - plot above shows raw counts over same interval

The question of just how this eventually came about is a significant one, for it is unprecedented in the flight history of these instruments, which have been assembled in-house, for well over a decade now. All the daily downlinks were therefore carefully scrutinized to see if the origin of the problem might somehow be discerned. It was not possible to tell from either spacecraft or instrument housekeeping data, if the origin of the problem lay with the detector portion of the instrument (i.e. with the Channeltron detector), or in the electronic components which follow it in the hardware circuitry. It was thought likely that in addition to basic Channeltron degradation, by whatever means (it is noted for example, that these detectors are uniformly stimulated across the entire energy spectrum, each time the satellite goes through the radiation belts), an increasing pulse height discriminator threshold due to drift, could also bring about the same end. It was of particular interest for example, to see if counts in any quantity, were to again reappear in the low energy ion spectra, for this would at least suggest that the problem does not originate in the electronics. In a bid to narrow the focus of the investigation, the initial recommendation to PL/GPSG was that they turn ON the Emitter when it was next convenient to do so, and examine the ESA response. Previously, this action resulted in a significantly large low energy ion flux being registered. If indeed the electronics circuitry is still operational, some indicative response should be observed, and possibly give the ion channel some utility for the remainder of the mission.

It happened that the APEX spacecraft developed operational difficulties before the suggested course of action could be tried. As a consequence, a period of approximately eight weeks transpired before regular instrument operations resumed. Shortly thereafter however, in gradual fashion, it was noticed that counts began to reappear in the low energy ion channel. Figure 3 illustrates how the ESA output appeared around this time and it is seen that significant counts can now be discerned in the low energy ion spectra. Interestingly, while low energy ions were being detected in the polar region, the broad sensor stimulus that was previously observed in the trapped radiation belt region, is still absent in the spectral display. Within a few weeks though, full functionality was restored to the instrument in virtually all respects. An indication of the ESA spectra from near the end of this report period is shown in Figure 4. The contrast with Figure 2, is strikingly clear, for it is seen that no evidence of missing data appears in the low energy ion spectra of Figure 4. The radiation belt spectra is as continuous as it was when the instrument was first powered ON shortly after launch.

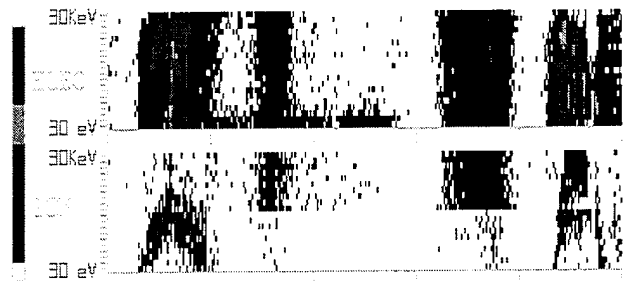
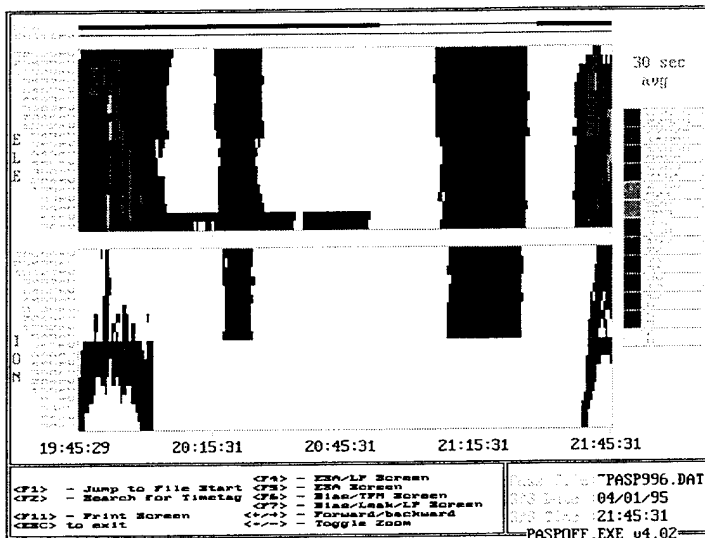

Figure 3: ESA Output showing partial return of Low Energy Ion Spectra  
 - plot on left shows 30sec averaged electron & ion data  
 - plot above shows raw counts over same interval

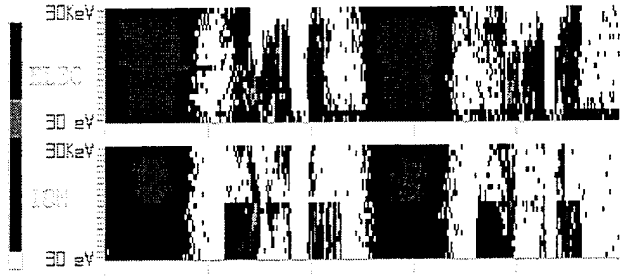
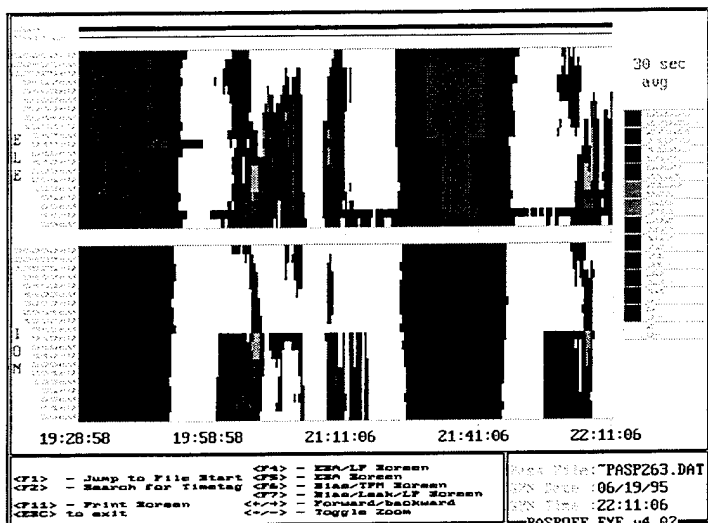

Figure 4: ESA Output showing full return of Low Energy Ion Spectra on 6/19/95  
 - plot on left shows 30sec averaged electron & ion data  
 - plot above shows raw counts over same interval

No determination has yet been made as to the cause of the ESA's anomalous behavior. From what can be discerned thus far however, the following is clear: (i) subsequent to the initial degradation of performance in the low energy ion channel, the condition persisted until power to the instrument was recycled. (ii) the low energy ion spectra first reappeared in the polar regions and then throughout the entire orbit. A full account of the instrument's performance would have to explain the role of these two eventualities as well as provide an explanation of how is it possible for one form of stimulus to show up in the data (as seen in Figure 2) and not the other. With the instrument's performance now seemingly back to nominal, it could be awhile before these issues are tackled and a clear resolution achieved among the interested parties.

### 3.0 TASK #2—CHAWS EFFORTS

#### 3.1 Summary of Activities

Consultative support was given to PL/GPSG on matters pertaining to the re-flight of the CHAWS payload, during the report period. One item on which a fair amount of discussion ensued, was the state of the biasing power supply within the unit, and whether or not it should be replaced or rebuilt in light of the operational difficulties it experienced on-orbit, during the first mission. For a number of reasons, time constraints not least among them, it was decided to do nothing in this regard.

An instrument has been earmarked to receive the novel *wedge and strip* anode which has been under development in-house for some time now. It is to be the Digital Ion Drift Meter (DIDM) instrument which will be a low cost, low power, lightweight, "proof-of-concept" digital plasma detector. The objective is to show the instrument to be a viable alternative to the present generation of analog sensors on operational spacecraft, by combining the functions of an ion drift meter and a retarding potential analyzer, to facilitate the accurate calculation of ion drift, over a wider range of ionospheric densities and with greatly enhanced resolution capability compared to what is currently possible.

The terms of reference for this task in the original technical proposal (BAA-1) was modified by PL/GPSG via a *Technical Proposal Amendment*, which became effective November 1994. Originally, the extent of effort to be expended on this task was: to investigate the relationship of ambient parameters to particle characteristics and to study the impact of vehicle charging potentials and sheath formation in the wake region of spacecraft in the Ionosphere, through the acquisition of on-orbit data in both the ram and wake regions of a wake formation shield. This is to be carried out as part of the Wake-Shield Facility program. In addition, we are now directed to: *Investigate the relationship of ambient parameters to particle characteristics and study the impact of space vehicle charging potentials in the vicinity of the space shuttle through the acquisition of on-orbit data in conjunction with the Tethered Satellite System/SPREE experiment.* The added amendment is italicized.

#### 3.2 DIDM Activities

Scheduled delivery of DIDM is slated for 10/30/96. Orbital insertion is to be achieved on a Pegasus launched STEP 4 satellite in June '97. Efforts are being ramped-up at Amptek, in order to meet these target dates. Consideration was given during the report period, to the specifics of some aspects of the DIDM instrument design. In particular, the on-board processing requirements of the instrument as it is currently envisaged, were looked at and an initial decision made on the choice of a microprocessor to be employed for the job. The implementation of a 1553B communication interface with the spacecraft was also examined. Vendors for the hardware were sought and details of the particular designs were scrutinized for power consumption and suitability for use in this space-flight application.

Amptek, Inc. personnel supported PL/GPSG at several meetings during the report period, which were convened to discuss either STEP 4 (the launch platform) or DIDM instrument design issues. An illustration of this is the Engineering Working Group meeting, which was held early in the calendar year at the spacecraft vehicle contractor's (TRW) facility in Chantilly VA. The principal focus of the gathering was to lay out for all concerned, the proposed communications interface to be employed on the satellite, between the vehicle and the payloads. The implementation of this MIL-STD-1553B protocol is a new experience for virtually all concerned, and it was deemed necessary to make design specifics known at an early date.

Amptek, Inc. personnel was also in the DIDM contingent at the STEP 4 Initial Design System Review which was held around the middle of the report period at TRW. This was a full briefing to the Air Force and payload providers, of the capability of the launch platform to meet mission requirements. Several Action Items to TRW were generated from the proceedings by DIDM, and virtually all were resolved in subsequent teleconferences among the parties concerned. In addition, several meetings were held both at Amptek, Inc. and PL/GPSG, to discuss DIDM instrument design issues. The subject matter during these gatherings ranged from detailing the specifics of the operating modes of the instrument, to discussing desired instrument functionality and how this might be achieved within the limitations imposed by the present design. A good deal of discussion ensued on the merits of various anode schemes and what it would require from both a hardware and engineering-time standpoint, to implement each. It is fair to say that despite PL/GPSG's efforts in generating a baseline configuration for the instrument, given the nature of the discussions regarding instrument functionality, a final consensus has not yet been achieved, with regard to the final configuration and capability of the instrument which will be flown.

### 3.3 SPREE Activities

The preparation of SPREE hardware for the forthcoming space flight on the shuttle continued during the report period. Consequently, this effort is now almost at an end. The Data Processing Unit, the Rotary Table Motor Drives and the Flight Data Recorders are installed on the SPREE mounting bracket at the Kennedy Space Flight Center. New Micro-Channel Plates have been installed into the ElectroStatic Analyzers and ion calibration for both units has been completed. In addition, Amptek, Inc. personnel participated in several conference calls and discussion groups, whose purpose was to iron out the specifics on verification requirements for the mission. Among the measures taken to prepare particular items of hardware to date, are the following:

**3.3.1: Rotary Table Motor Drives (RTMD's)** The flight hardware was installed on the mock-up of the SPREE Mounting Bracket and the control range of the motors, as well as, DPU operation were tested. A very bright solar lamp was used to illuminate the drive sensors, in an attempt to simulate the effect of the sun on the sensor's detection circuitry. The exercises were event free and no anomalous behavior was observed.

Additionally, both capture rings were disassembled and removed from the rotary table surface, in order to inspect the reflective photo-emitter and reflective surface. It was found that RTMD-B (the unit which occasionally became disoriented on TSS-1) had the photo-emitter assembly position  $\approx 0.100''$  further from reflective lip of the rotary table than was desired. This spacing was adjusted for RTMD-B. It was also necessary to repaint the sensing surface of the reflective opto-sensor for both units, with a flat black (flight approved) paint, to increase their detection margin. At times, the original anodized surface in RTMD-A displayed marginal detection ability due to its infrared reflection characteristic. The tables were reassembled and tested in a thermal chamber to ensure the proper engineering margin for the position detection scheme. It was noted that the detection margin for both units was improved by a factor of three in the process. As a final step, all associated screws were re-torqued and the tables were vibration tested.

**3.3.2: ElectroStatic Analyzers A and B (ESA's)** New Micro Channel Plates were ordered and installed in the units so that these critical elements would have a known and reliable gain for the duration of the mission. The MCP strip current and bulk resistance were verified for the instruments. The resistive components necessary to achieve detection thresholds to within 12 mV were calculated and appropriate resistors installed. Several operational runs were then carried out, under vacuum, in order to identify and install the proper thresholds for the ESA charge sensitive preamplifiers. These levels were finally set to 34 mV threshold (2 pf and 50 ohms).

Both ESAs were then calibrated using the ion source in the MUMBO calibration chamber at PL/GP. In an effort to further characterize the units, some Real versus Apparent count rate tests were carried out. The tests were only partially successful using either the ion source or a hot filament electron gun. Count rates up to 800,000 were induced, but the beam densities necessary to achieve these rates caused the ion/electron source to deteriorate in both angular and energy homogeneity. All attempts to avoid this problem failed.

Still to be carried out on the ESAs are electron calibration, vibration testing and limited thermal vacuum testing. All of which must be accomplished prior to delivery to KSC. The present due date is tight, but achievable.

**3.3.3: Data Processor Unit (DPU)** Consultative meetings were held with Dr. Paul Gough (University of Sussex, UK) regarding the manner in which data was processed by this unit. As a result of these discussions, some changes were implemented in the hardware, largely to reprogram a FPGA to generate two output frequency ranges, rather than the three generated in the previous TSS-1 configuration. A careful inspection of the interior of DPU was then carried out, in order to ensure that at least from a visual standpoint, everything appeared to be in nominal condition. The cover of the unit was then resealed and the unit was subjected to both thermal and vibration testing.

**3.3.4: Flight data Recorders (FDR's)** The two Flight Data Recorders were refurbished to the extent that new flight tapes were installed, which were then reformatted to the file length and format used by SPREE. The exercise had to be repeated however, due to a test chamber temperature regulation anomalous event, which occurred during the time the entire SPREE payload was being thermally cycled. The resulting thermal shock had the greatest impact on the FDRs. Tape spools warped and the tape became unstable due to the heat. Additional problems also surfaced subsequent to the replacement of those tapes. The heater circuit of FDR1 failed and subsequent investigation found a bad transistor to be the cause. It was replaced. On resumption of the thermal vacuum test both recorders gradually developed problems which were traced to excessive heating of the tape. The FDRs were reopened, cleaned, and had new tape installed. Testing temperature profile was revised to limits which will not be exceeded in the shuttle mission. The units were resealed, vibration and thermal vacuum tested. Proper functionality was observed throughout. Despite their having pass the environment tests, in light of the difficulties experienced with the units however, the decision was made to deliver the FDRs to NASA, but to prepare a flight spare that could be quickly substituted if one of the FDR units fails during integration testing at the KSC. This unit is currently being assembled.

**3.3.5: Miscellaneous** The integration, testing and support phase of the SPREE program at KSC is also proceeding apace. The SPREE Interface Verification Test and a Mission Sequence Test were both successfully concluded during the report period. Currently, in parallel with other activities, various operational materials are being updated and/or improved in order to assist mission personnel during the re-flight. An improved telemetry map, an append list for the FDRs, and a time tagging procedure are examples of these refinements.

## 4.0 TASK #3—OEDIPUS-C EFFORTS

### 4.1 Summary of Activities

All outstanding issues regarding the two EPI Electronics Modules to be flown on the OEDIPUS-C sounding rocket were completed during the report period, and the instruments were delivered to PL/GPSG early in the last quarter. Details on the activities which took place and the issues which were resolved in order to accomplish this end, follow.

### 4.2 Software Functionality Verification

Flight software functionality was rigorously tested as the first step in a series of functionality checks, which were carried out to establish that instrument performance was as designed and that mission expectations can be met. From this exercise, it became necessary to make small modifications to the code, in order to rectify apparent deficiencies. These include the following: (i) software changes to ensure that the correct number of bytes was consistently placed in the output telemetry, and to include output pointers showing where the spectra, MCU data, and HF data were with respect to the rest of the telemetry. (ii) decoupling the internal data buffering from the major frame pulses and making the buffering solely dependent on data quantity, which effectively, locks it to the transmitter pulse repetition frequency (PRF). (iii) use the major frame pulse was restricted solely to correct the synchronization of the frequency labeling output data blocks. Within each block of telemetry data, the MCU data and HF data can now be identified by simple reference to the spectra data. The actual energy levels and transmitter frequency steps are also placed in the data stream. Overall, these software changes result in CPU processing being independent of the actual sequence of energy levels used, and in general, makes instrument functionality much more reliable.

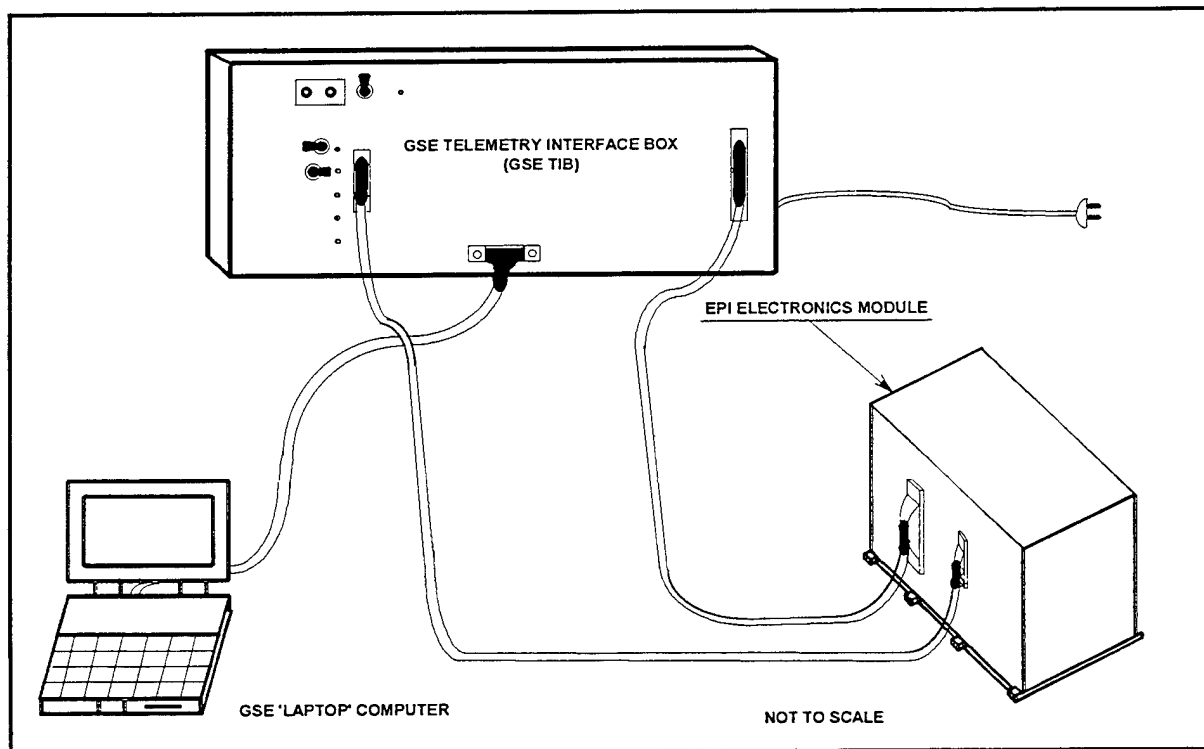

Figure 5: EPI Electronics Module Test Setup

### 4.3 Environmental Testing

The EPI Electronics Modules were subjected to Random Vibration, Thermal Cycling and EMI/EMC environmental testing, as part of the instrument flight qualification process. Both units went through the first two tests without a hitch. Only one unit-the FORE module-was EMI/EMC tested. Necessarily, both the unit and an EPI Sensor were connected together and operated in nominal fashion during the course of the test. From the test results, good knowledge of the Energetic Particle Instrument suite's emission profile was obtained, and circumstances in which the instruments become susceptible to electromagnetic interference were identified.

In order to exercise the instrument during functionality and environmental testing, additional capability was added to the GSE Telemetry Interface Box (GSE TIB). This is a unit whose primary function is to support launch activities; i.e. to receive the downlinked telemetry and enable its display in real-time. Test Modules were added in order to accomplish the following: (i) power an Electronics Module; (ii) simulate the OEDIPUS-C payload telemetry interface on the rocket; and (iii) simulate the EPI Sensor outputs. When connected to these interfaces, an Electronics Module is effectively placed in flight configuration and it is then possible to stimulate the unit in a known fashion, request data from it in a manner identical to used during flight and predictably receive its output telemetry, so that its performance could be monitored. A functional schematic of the GSE TIB is shown below in Figure 6.

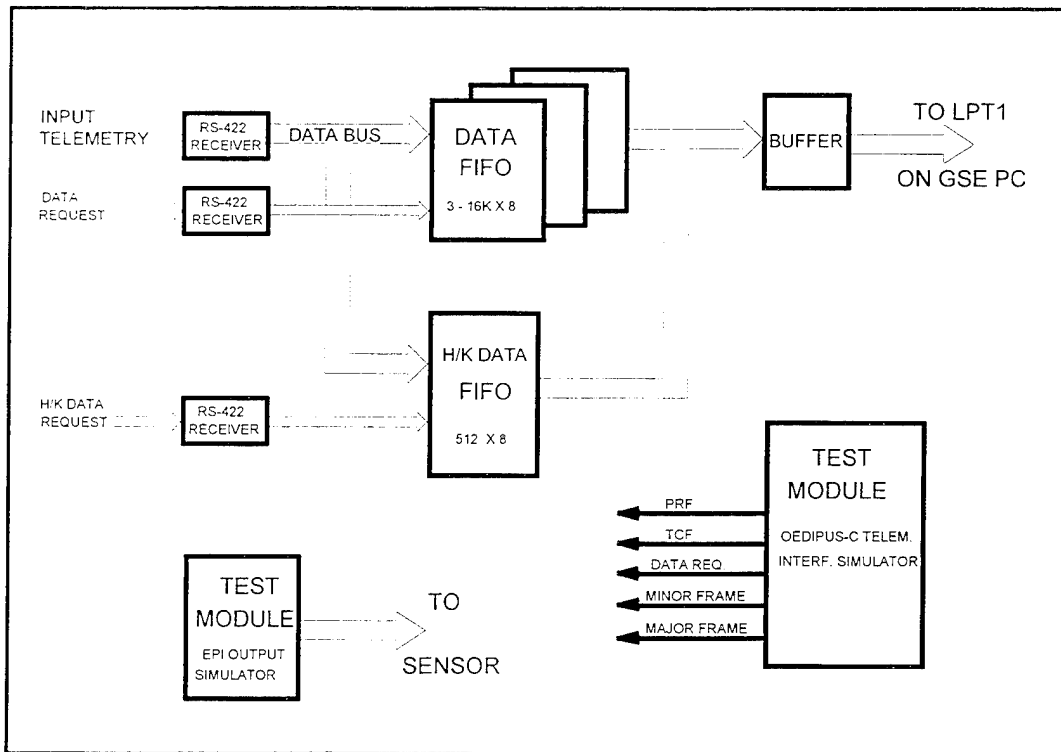

Figure 6: EPI GSE Telemetry Interface Box (GSE TIB) Schematic

The actual test setup configuration is represented in Figure 5. Software running on a *laptop* computer facilitates the interface between the GSE TIB and an Electronics Module. Instrument status is also shown on its display panel. The portability inherent to *laptops*, and the latest in present day hardware capabilities (486-100 MHz processor, color monitor and bi-directional parallel port) makes such a PC ideally suited for the job.

