

index

19951226 095

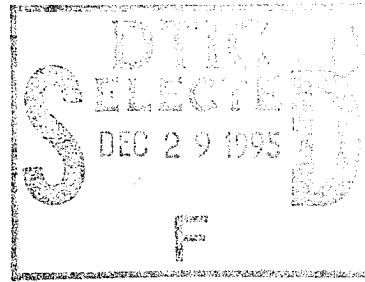

Design, Ancillary Testing, Analysis, and Fabrication Data for the Advanced Composite Stabilizer for Boeing 737 Aircraft

DISTRIBUTION STATEMENT B
Approved for public release;
Distribution Unlimited

Volume I - Technical Summary

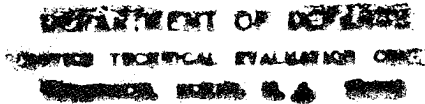

R. B. Aniversario, S. T. Harvey,
J. E. McCarty, J. T. Parsons,
D. C. Peterson, L. D. Pritchett,
D. R. Wilson, and E. R. Wogulis

CONTRACT NAS1-15025
APRIL 1983



25th Anniversary
1958-1983



FOR EARLY DOMESTIC DISSEMINATION
Because of its possible commercial value, this data developed under U.S. Government contract NAS-15025 is being disseminated within the U.S. in advance of general publication. This data may be published and used by the recipient with the expressed limitations that the data will not be published and used by other parties without prior permission of The Boeing Company. Release of this data to other domestic parties by the recipient shall only be made subject to these limitations. The limitations contained in this legend will be considered void after December 1984. This legend shall be marked on any reproduction of this data in whole or in part.

PLASTED

NASA Contractor Report 3648

Design, Ancillary Testing, Analysis, and Fabrication Data for the Advanced Composite Stabilizer for Boeing 737 Aircraft

Volume I - Technical Summary

R. B. Aniversario, S. T. Harvey,
J. E. McCarty, J. T. Parsons,
D. C. Peterson, L. D. Pritchett,
D. R. Wilson, and E. R. Wogulis
*Boeing Commercial Airplane Company
Seattle, Washington*

Prepared for
Langley Research Center
under Contract NAS1-15025



National Aeronautics
and Space Administration

Scientific and Technical
Information Branch

1983

Accession For	
NTIS CRA&I	<input checked="" type="checkbox"/>
DTIC TAB	<input type="checkbox"/>
Unannounced	<input type="checkbox"/>
Justification	
By	
Distribution /	
Availability Codes	
Dist	Avail and/or Special
A-1	

FOREWORD

This technical summary (vol. I) and a final technical report (vol. II, ref. 1) were prepared by the Boeing Commercial Airplane Company, Renton, Washington, under NASA Contract NAS1-15025. They cover work performed between July 1977 and December 1981. The program was sponsored by the National Aeronautics and Space Administration, Langley Research Center (NASA-LRC). Dr. Herbert A. Leybold, Marvin B. Dow, and Andrew J. Chapman were the NASA-LRC project managers.

The following Boeing personnel were principal contributors to the program:

Program Director
S. T. Harvey

Design
G. Ohgi
R. J. Nicoli
E. R. Wogulis
W. C. Brown

Structural Analysis
D. R. Wilson
R. W. Johnson
J. E. McCarty

Weight and Balance Analysis
G. Nishimura
J. T. Parsons
R. E. Baum

Manufacturing Technology
M. C. Garvey
V. S. Thompson
E. S. Jamison

Production Manager
J. E. Gallant
W. D. Grant

Technical Operations Manager
L. D. Pritchett

Business Management
C. M. Lytle
M. R. Wiebe
D. V. Chovil

SUMMARY

This is the technical summary for the design, ancillary testing, analysis, and fabrication detail for the NASA Aircraft Energy Efficiency (ACEE) program on the Boeing 737 commercial transport. It covers all work performed on the program from July 1977 through December 1981.

Program objectives were to design and produce an advanced composite stabilizer that would meet the same functional criteria as those for the existing metal stabilizer. Preliminary design activities were devoted to developing and analyzing alternative design concepts and selecting the final configuration. Trade studies evaluated durability, inspectability, producibility, repairability, and customer acceptance. Preliminary development efforts were devoted to evaluating and selecting material, identifying structural development test requirements, and defining full-scale ground and flight test requirements necessary to obtain Federal Aviation Administration (FAA) certification.

After selecting the best structural arrangement, detail design started and included basic configuration design improvements resulting from manufacturing verification hardware, the test program, weight analysis, and structural analysis. Nonautomated detail and assembly tools were designed and fabricated to support a full-scale production program rather than a limited run. The producibility development programs verified tooling approaches, fabrication processes, and inspection methods for the production mode. Quality parts were fabricated and assembled with a minimum rejection rate, using existing inspection methods.

Basic program goals were:

- To make extensive and effective use of advanced composite material
- To obtain a minimum weight reduction of the composite stabilizer over the metal stabilizer of 20%
- To demonstrate cost effectiveness of a composite structure and collect cost data

All program technical goals were realized when the design met or exceeded all established design requirements, criteria, and objectives with an FAA certification granted in August of 1982. Actual program cost experience showed that composite structure is not currently competitive with metal. Composite structures can become competitive by applying automated manufacturing methods and engineering designs tailored to automation.

Manufacturing of the component stabilizer was performed in a semiproduction environment by production employees. Hand methods were used for cutting and layup of broadgoods, ply-by-ply inspection, and trimming. The limited production quantity of five-and-one-half shipsets did not warrant automated manufacturing that would be used in quantity production; therefore, a cost-competitive status with metal could not be demonstrated by the actual program cost. Automated manufacturing methods and the expected reduction in relative material cost will aid in achieving cost parity with metal structure.

CONTENTS

	Page
1.0 INTRODUCTION	1
2.0 SYMBOLS AND ABBREVIATIONS	3
3.0 TECHNICAL APPROACH	5
3.1 Design	5
3.1.1 Material Evaluation and Selection	7
3.1.2 Structural Concepts	8
3.1.3 Environmental Protection Systems	14
4.0 ANALYSIS AND TEST	19
4.1 Analysis	19
4.1.1 Environmental Analysis	19
4.1.2 Design Values	19
4.1.3 Finite Element Analysis	20
4.1.4 Bird Strike Analysis	22
4.2 Ancillary Testing	22
4.3 Environmental Test Panel	28
4.4 Weights	30
5.0 FABRICATION DEVELOPMENT	33
5.1 Trade and Producibility Studies	33
5.2 Ancillary Test Component Fabrication	35
5.3 Manufacturing Verification Hardware	40
5.4 Quality Assurance Development	44
5.4.1 Nondestructive Inspection Development	44
5.4.2 Discrepancy Analysis	48
6.0 CONCLUSIONS	51
7.0 REFERENCES	53

FIGURES

		Page
1	Program Technical Approach	6
2	Metal Horizontal Stabilizer	7
3	Stabilizer Box Concepts	8
4	Skin Panel Concepts	9
5	Spar Lug Concepts	9
6	Rib Concepts	10
7	Advanced Composite Horizontal Stabilizer	11
8	Stabilizer Inspar Structural Arrangement	11
9	Skin Panel	12
10	Typical Inspar Rib	12
11	Front and Rear Spars	13
12	Center Section Interfaces	14
13	Stabilizer Lightning Protection	15
14	Lightning Protection System	15
15	Corrosion Protection System	17
16	Thermal Compensating Mechanism	18
17	Finite Element Model Substructure Definition	20
18	Example of Finite Element Analysis Model Strain Distribution	21
19	Example of Thermal-Induced Strains	21
20	Example of Moisture-Induced Strains	22
21	Ancillary Test Plan	23
22	Stub Box Test Plan	24
23	Stub Box Test Setup	26
24	Stub Box Damage Tolerance Test—Front-Spar Upper Chord, Skin, and Leading Edge	27

	Page
25	Stub Box Damage Tolerance Test—Lower Surface Skin and Stringer 27
26	Stub Box Damage Tolerance Test—Rear-Spar and Lower Chord 28
27	Stabilizer Rear-Spar Lower Chord and Skin 29
28	Environmental Test Panel 30
29	Comparison of Strain Gage and Analytical Model Prediction for Environmental Panel Test 31
30	Layup of I-Section Stiffeners 33
31	I-Stiffened Panel Tooling Approach 34
32	Tool Concept of I-Section Stiffeners 34
33	Corrugated Inspar Rib 35
34	Honeycomb Inspar Rib 36
35	Spar Lug Concepts 36
36	Ancillary Test—Typical Tensile Specimens 37
37	Spar Chord Crippling—Specimen Ready for End Potting 37
38	Panel-to-Rib Joint Test 38
39	Panel-to-Rib Joint Test 38
40	Compression Test Panel—Stiffened Side 39
41	Spar Lug—Completed Compression Specimens 40
42	Stub Box Front Spar—Completed Details Being Inspected 41
43	Stub Box I-Stiffened Skin Panel—Layup of I-Stiffeners 41
44	Stub Box I-Stiffened Skin Panel—Trimmed Part 42
45	Stub Box—Trailing-Edge Beam, Rear Spar, and Graphite-Epoxy Ribs in Place 42

		Page
46	Stub Box—Front and Rear Spar, Lower Skin Panel, and Ribs With Instrumentation	43
47	Stub Box—Front View of Completed Assembly	43
48	Honeycomb Rib—Evolution of Design	44
49	Nondestructive Inspection Standards for Test Technique Evaluation	45
50	Nondestructive Inspection Standard Layup With Defect Inclusions	45
51	Fokker Bond Testing of Rear-Spar Assembly	46
52	Sondicator Inspection of Rear-Spar Assembly	46
53	Automated Through-Transmission Inspection— Large Structures	47
54	Through-Transmission Ultrasonic Inspection— Details	47
55	Fokker Bond Testing of Skin-to-Cap Bond of I-Stiffener Panel	48
56	737 Stabilizer Accept/Reject Evaluation	49

TABLES

1	Summary of Results of Element and Structural Detail Ancillary Test Program	25
2	Composite Stabilizer Inspar Structure Weight Comparison	32

1.0 INTRODUCTION

The escalation of aircraft fuel prices has motivated assessment of new technology concepts for designing and building commercial aircraft. Advanced composite materials, if used extensively in airframe components, offer high potential for reducing structural weight and thereby direct operating costs of commercial transport aircraft. To achieve the goal of production commitments to advanced composite structures, there is a need to convincingly demonstrate that these structures save weight, possess long-term durability, and can be fabricated at costs competitive with conventional metal structures.

To meet this need, NASA has established a program for composite structures under the Aircraft Energy Efficiency (ACEE) program. As part of this program, Boeing has redesigned and fabricated the horizontal stabilizer of the 737 transport using composite materials, has submitted data to FAA, and has obtained certification. Five shipsets of composite stabilizers have been manufactured to establish a firm basis for estimating production costs and to provide sufficient units for evaluation in airline service. This work has been performed under NASA Contract NAS1-15025.

The broad objective of the ACEE Composite Structures program is to accelerate the use of composite structures in new transport aircraft by developing technology and processes for early progressive introduction of composite structures into production commercial transport aircraft. Specific objectives of the 737 Composite Horizontal Stabilizer program were to:

- Provide structural weight at least 20% less than the metal stabilizer.
- Fabricate at least 40% by weight of the stabilizer constituent parts from advanced composite materials
- Demonstrate cost competitiveness with the metal stabilizer
- Obtain FAA certification for the composite stabilizer
- Evaluate the composite stabilizer on aircraft in airline service

To achieve these objectives, Boeing concentrated efforts on conceiving, developing, and analyzing alternative stabilizer design concepts. After design selection, the following were performed: materials evaluation, ancillary tests to determine material design properties, structural elements tests, and full-scale ground and flight tests to satisfy FAA certification requirements. Specific program activities to achieve objectives included:

- Program management and plan development
- Establishing design criteria
- Conceptual and preliminary design
- Manufacturing process development
- Material evaluation and selection
- Verification testing
- Detail design
- FAA certification

Work accomplished in each of these areas is summarized in this document and described in detail in Reference 1.

NOTE: Certain commercial products are identified in this document in order to specify adequately the characteristics of the material and components under investigation. In no case does such identification imply recommendation or endorsement of the product by NASA or Boeing, nor does it imply that the materials are necessarily the only ones available for the purpose.

2.0 SYMBOLS AND ABBREVIATIONS

ACEE	aircraft energy efficient
BMS	Boeing Material Specification
FAA	Federal Aviation Administration
FAR	Federal Aviation Regulation
IR&D	independent research and development
$K_{B\infty}$	"B" basic factor for infinite sample
VMF	variation magnification factor
v	variance

3.0 TECHNICAL APPROACH

The technical approach used to design and develop the composite stabilizer, which met the interchangeability and stiffness criteria of the existing metal stabilizer, is shown in Figure 1. During the preliminary design phase, alternative design concepts were developed and analyzed. These studies resulted in the selection of the stabilizer configuration. Trade studies were used to evaluate durability, inspectability, producibility, repairability, and customer acceptance.

The preliminary development phase included evaluation and selection of materials, identification of ancillary structural development test requirements (including all testing except ground and flight tests of the full-scale component), manufacture of verification hardware, and definition of the full-scale ground and flight test requirements necessary to obtain FAA certification.

The detail design reflected design improvements resulting from verification hardware tests, the ancillary test program, and weight and structural analysis. Ground and flight testing activities completed the program. Production-quality fabrication and assembly tools were designed and fabricated to support a production program rather than a development program. The producibility development programs were used to verify tooling approaches, fabrication processes, and inspection methods for the production mode and to identify costs associated with the short production runs.

3.1 DESIGN

The composite stabilizer was designed to meet the same criteria as the existing metal stabilizer shown in Figure 2 and was required to comply with both Federal Aviation Regulations and Boeing structural design criteria for model 737. Additional criteria were:

- The composite stabilizer would be interchangeable with the existing production metal stabilizer.
- The airplane flight or handling characteristics would not be significantly changed with the installation of an advanced composite horizontal stabilizer. The advanced composite stabilizer would closely match the existing metal stabilizer's bending and torsional stiffness.
- The geometry and aerodynamic shape of the advanced composite stabilizer would be the same as the existing model 737 stabilizer.
- The structure would be designed as damage-tolerant (fail-safe).
- The strength, durability, inspectability, and serviceability would be equivalent to, or better than, that of the metal stabilizer.
- Maintenance and repair procedures would be developed for airline use.

In addition to the preceding criteria, the following contract objectives were imposed:

- The component weight target would reduce the weight of the redesigned structure by a minimum of 20%.

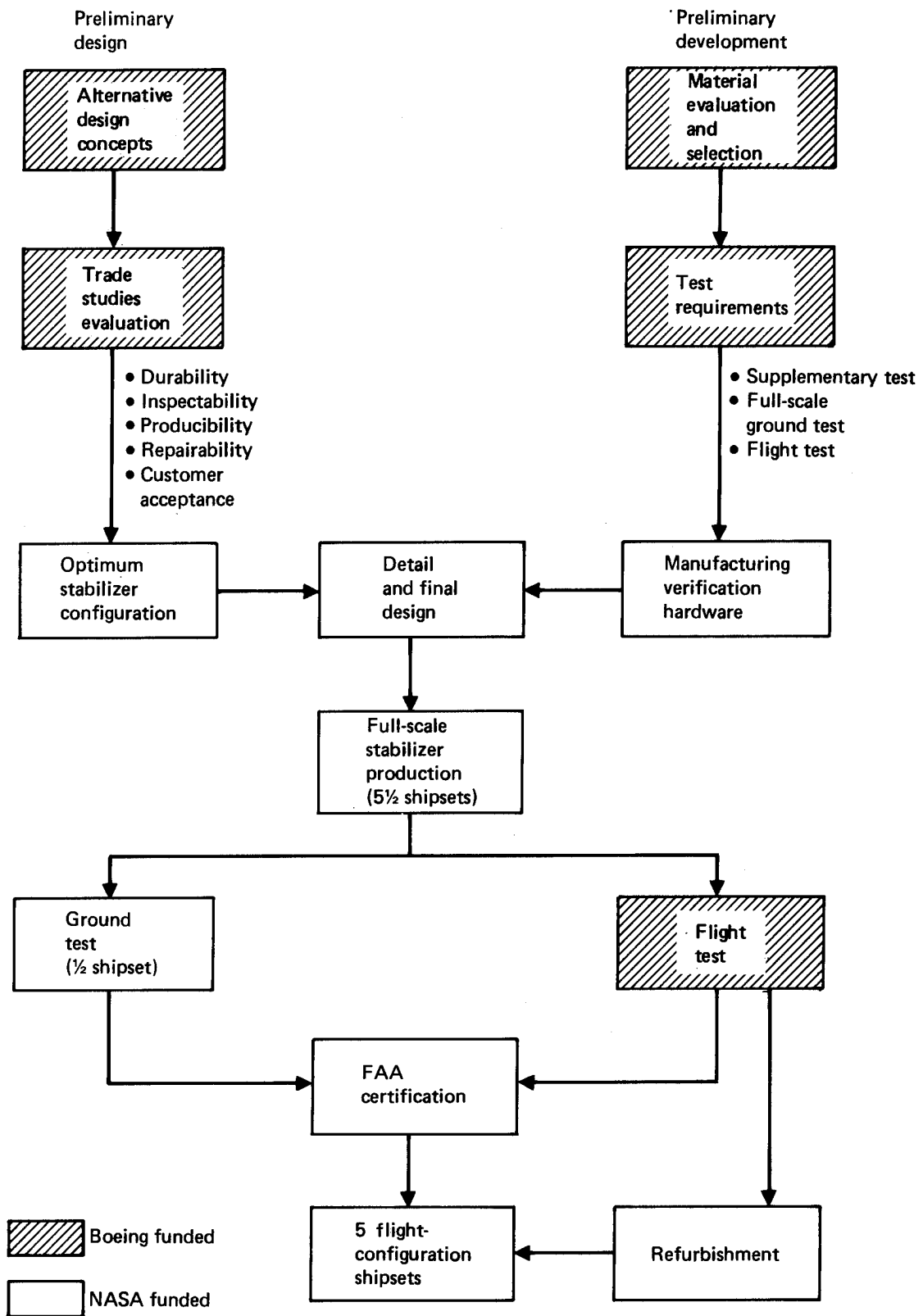

Figure 1. Program Technical Approach

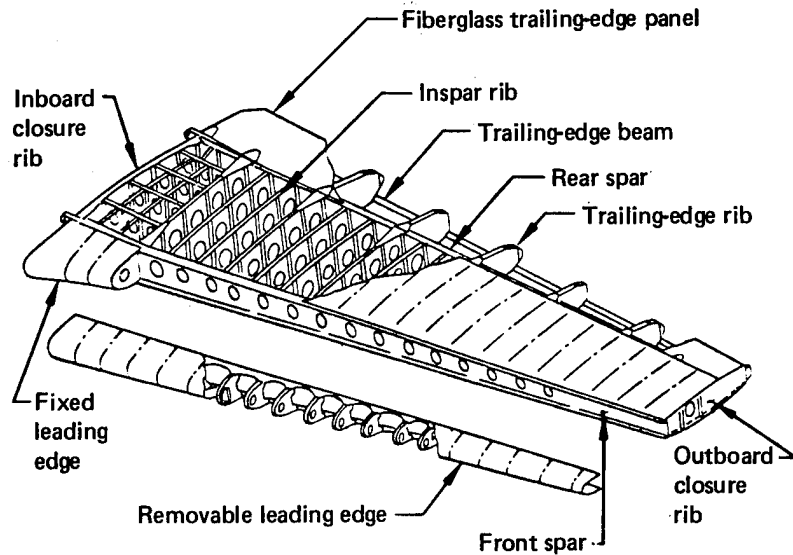

Figure 2. Metal Horizontal Stabilizer

- The production cost of the composite stabilizer would be cost competitive with the metal stabilizer at the same unit number.

Major design areas evaluated were materials and their selection, configuration, and environmental protection systems. These are discussed in the following sections.

3.1.1 Material Evaluation and Selection

A Boeing-sponsored independent research and development (IR&D) program selected and evaluated possible material systems using the tests and manufacturing considerations discussed in this section. The graphite fiber-epoxy resin systems investigated were:

<u>Graphite Fiber-Epoxy Resin System</u>	<u>Supplier</u>
T300/5208	Narmco
T300/5235	Narmco
T300/934	Fiberite
T300/976	Fiberite
AS/3501-5A	Hercules
T300/F263	Hexcel
T300/F288	Hexcel

Each prepreg system was ordered and tested in three forms: 2-ply preplied tape, unidirectional tape, and plain-weave fabric. The materials were ordered to comply with specific tolerances on prepreg and cured laminate physical properties. Physical properties testing of the resin, prepreg, cured laminate, and honeycomb was followed by manufacturing producibility comparisons including drape, tack, work time and layup difficulty. Other factors affecting the material selection included resin environmental durability and supplier production experience, capacity, and control. The Narmco T300/5208 system was selected because it best satisfied a majority of the selection criteria. The material form was predominantly fabric with selected application of tape.

3.1.2 Structural Concepts

The three concepts shown in Figure 3 were considered. Because the weights of these concepts were comparable, the stiffened skin concept was selected for its cost savings potential. In addition, the design concept, technology, and experience for the stiffened skin concept are directly applicable to a more highly loaded primary structure.

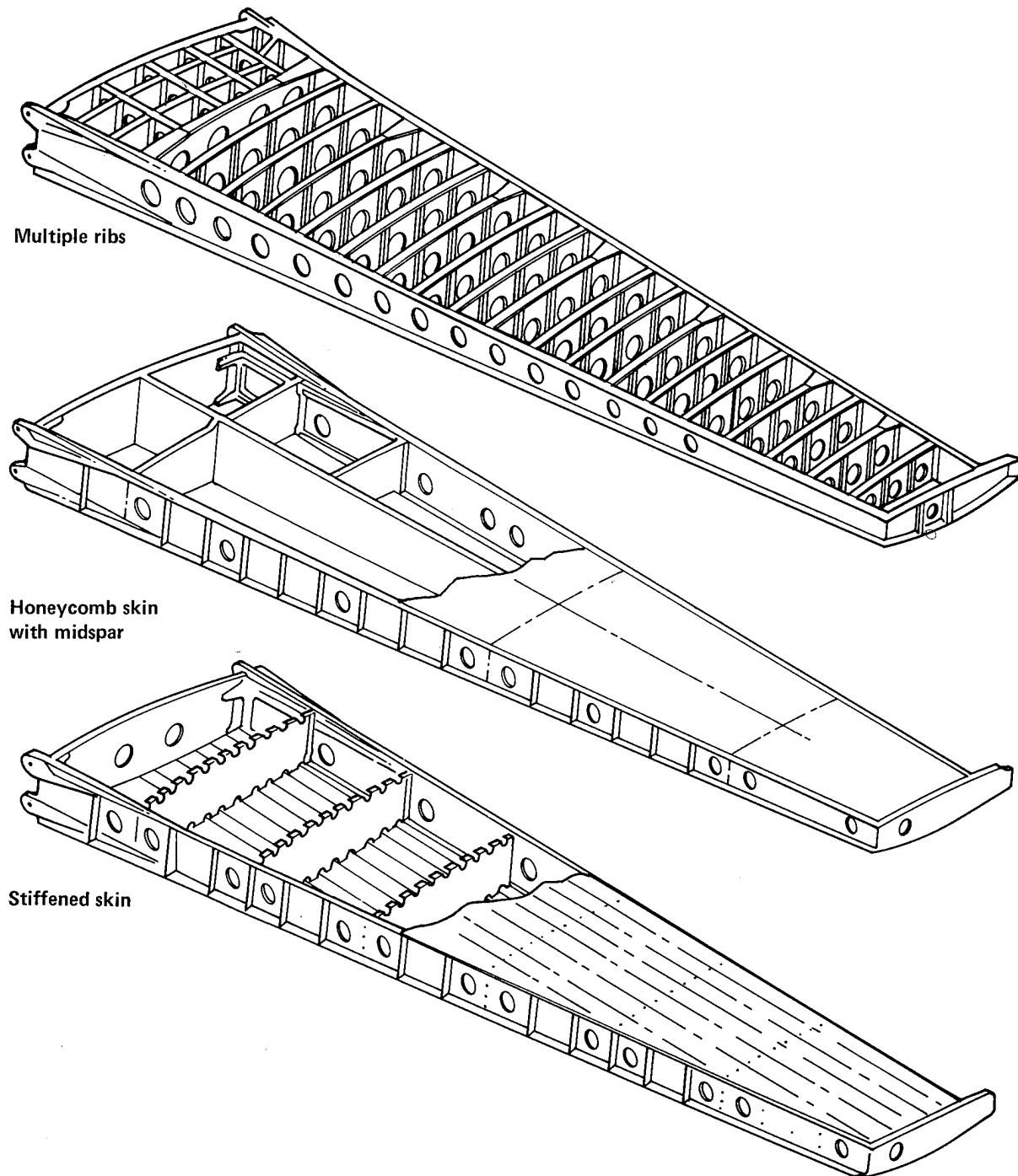

Figure 3. Stabilizer Box Concepts

After selecting the stiffened skin concept, three skin stiffening designs (fig. 4), three spar lug designs (fig. 5), and two rib configurations (fig. 6) were evaluated. Based on these trade studies, the estimated minimum cost and risk concepts were selected. The design concepts that featured a minimum number of detail parts and fasteners, permitted simplified tooling and fabrication schemes, and were amenable to available engineering analysis methods tending to be minimum cost and minimum risk. The resulting composite stabilizer design is shown in Figures 7 and 8. The design incorporates graphite-epoxy cocured, I-stiffened upper and lower surface laminate panels (fig. 9). The selected rib configuration is fully shear-tied with a honeycomb sandwich web (fig. 10). The spars are I-section solid laminates (fig. 11) with mechanically attached stiffeners. The box is then assembled with mechanical fasteners. The point of interchangeability with the center section

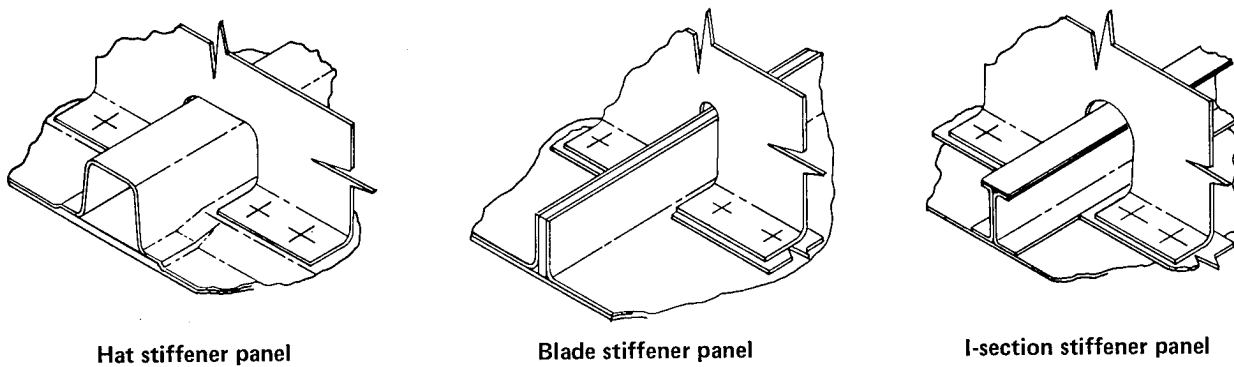

Figure 4. Skin Panel Concepts

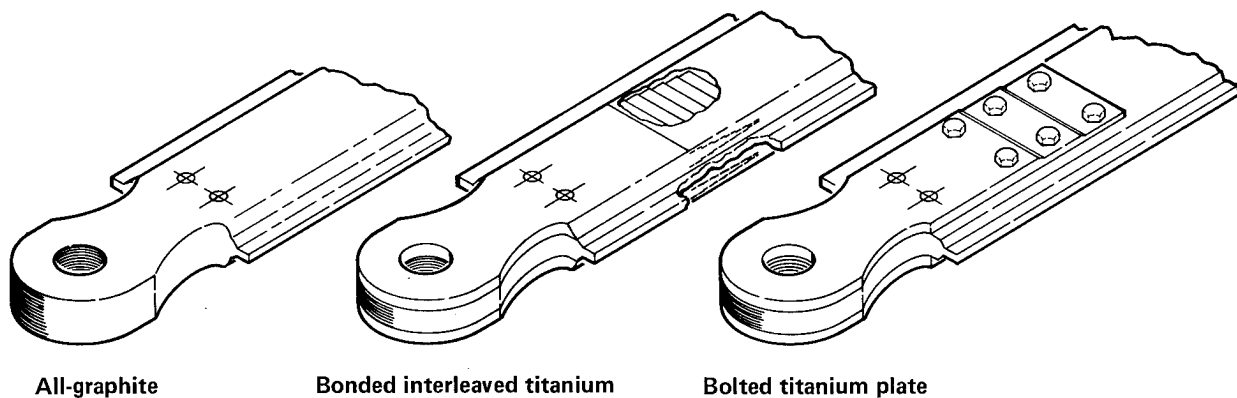
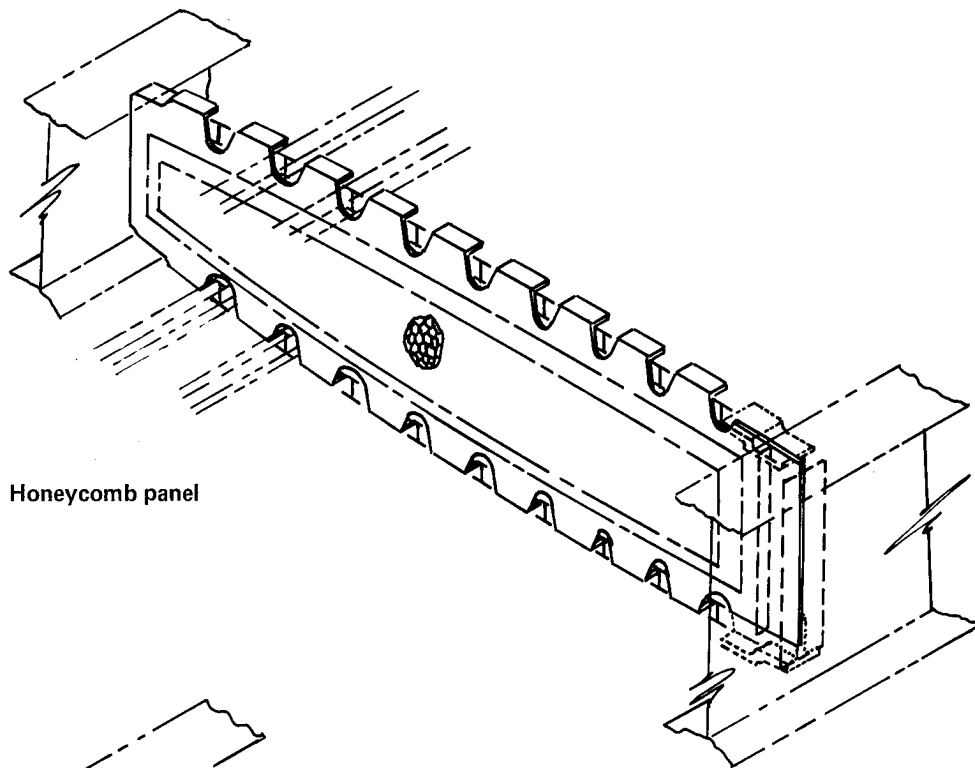
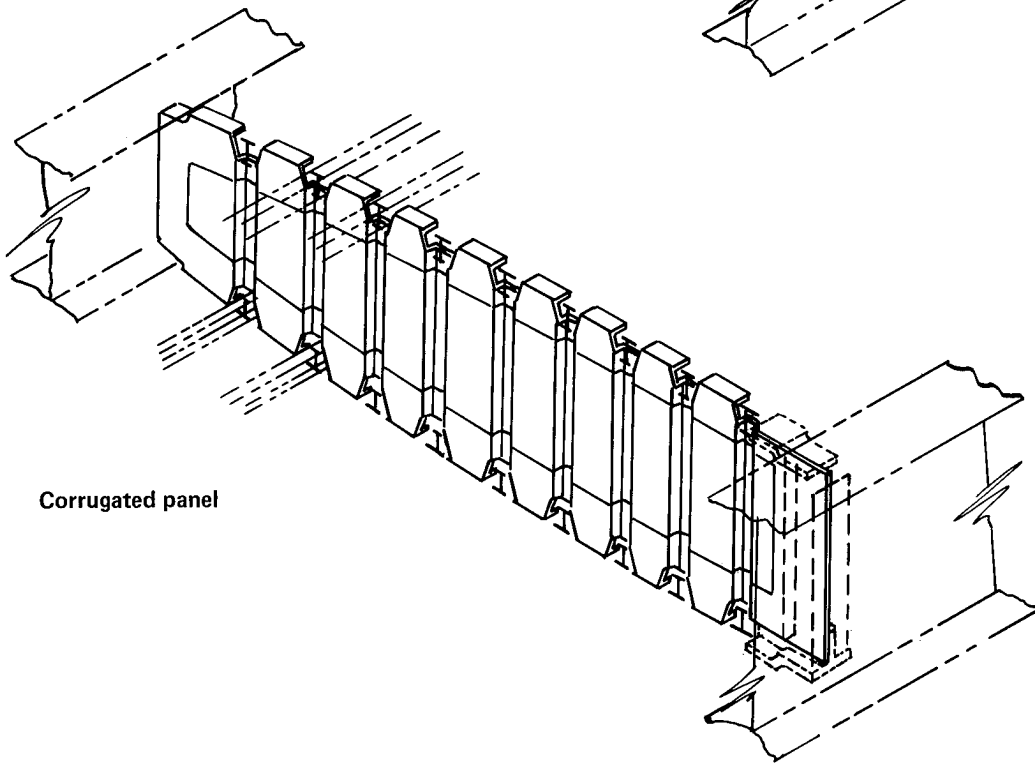

Figure 5. Spar Lug Concepts



Honeycomb panel



Corrugated panel

Figure 6. Rib Concepts

*Same for upper and lower panel

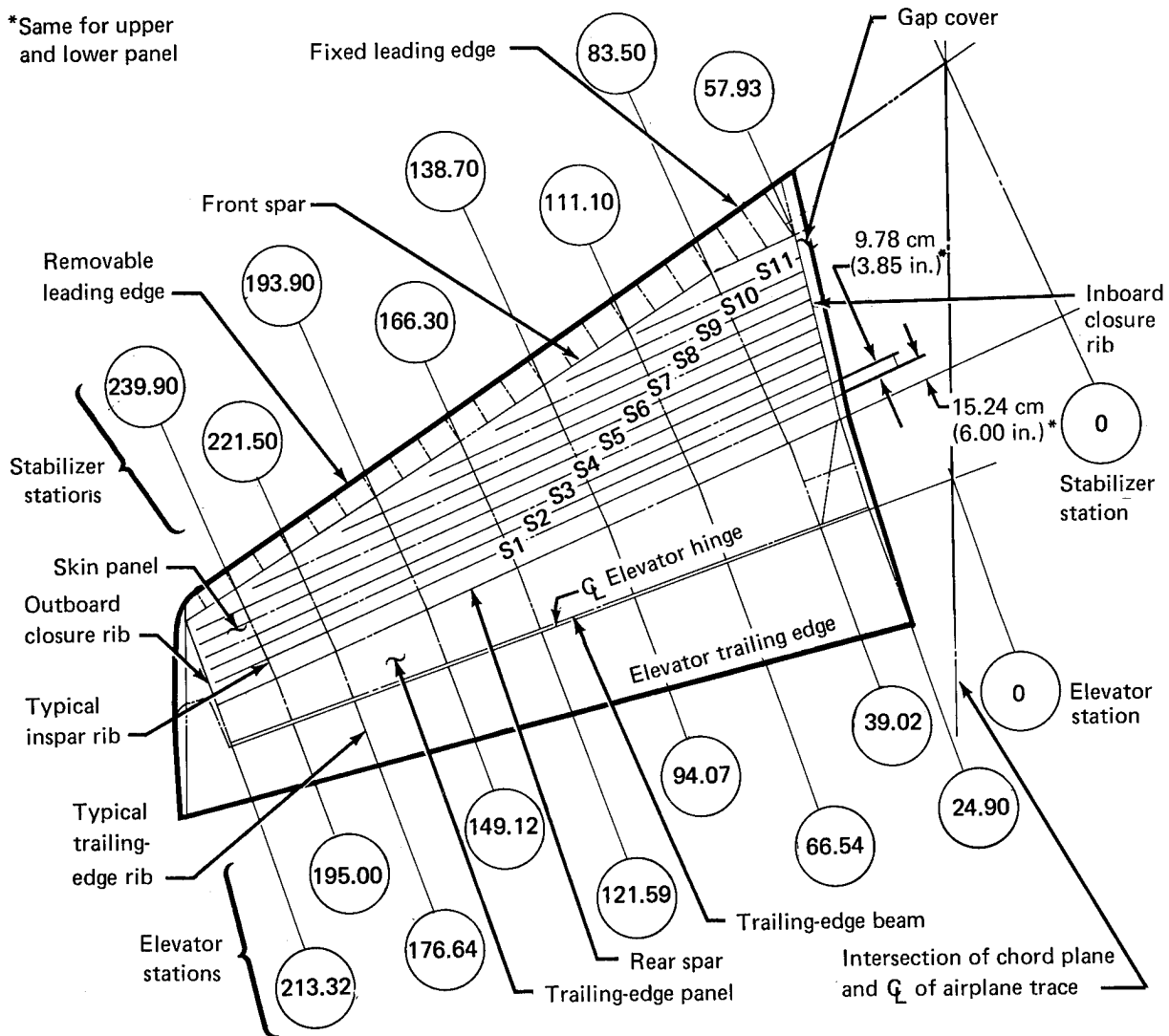

Figure 7. Advanced Composite Horizontal Stabilizer

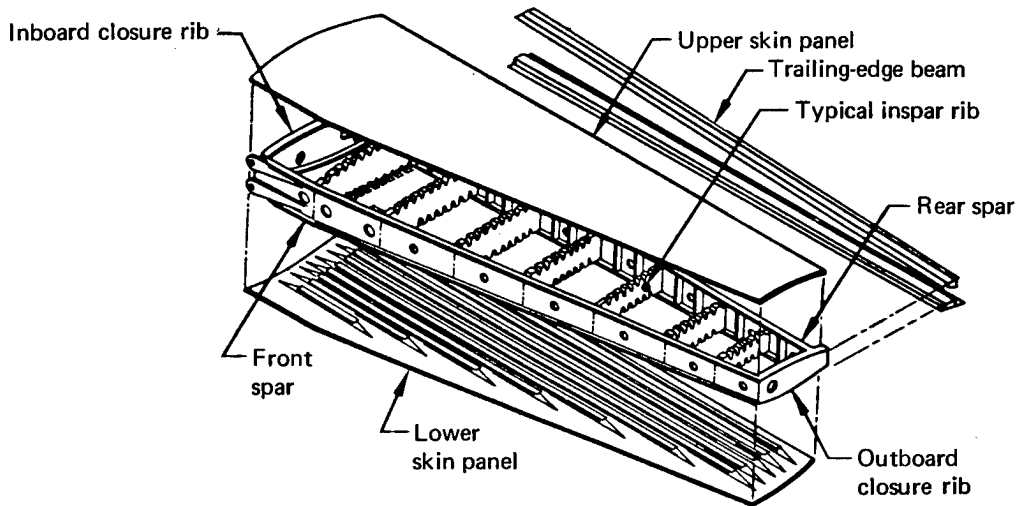

Figure 8. Stabilizer Inspar Structural Arrangement

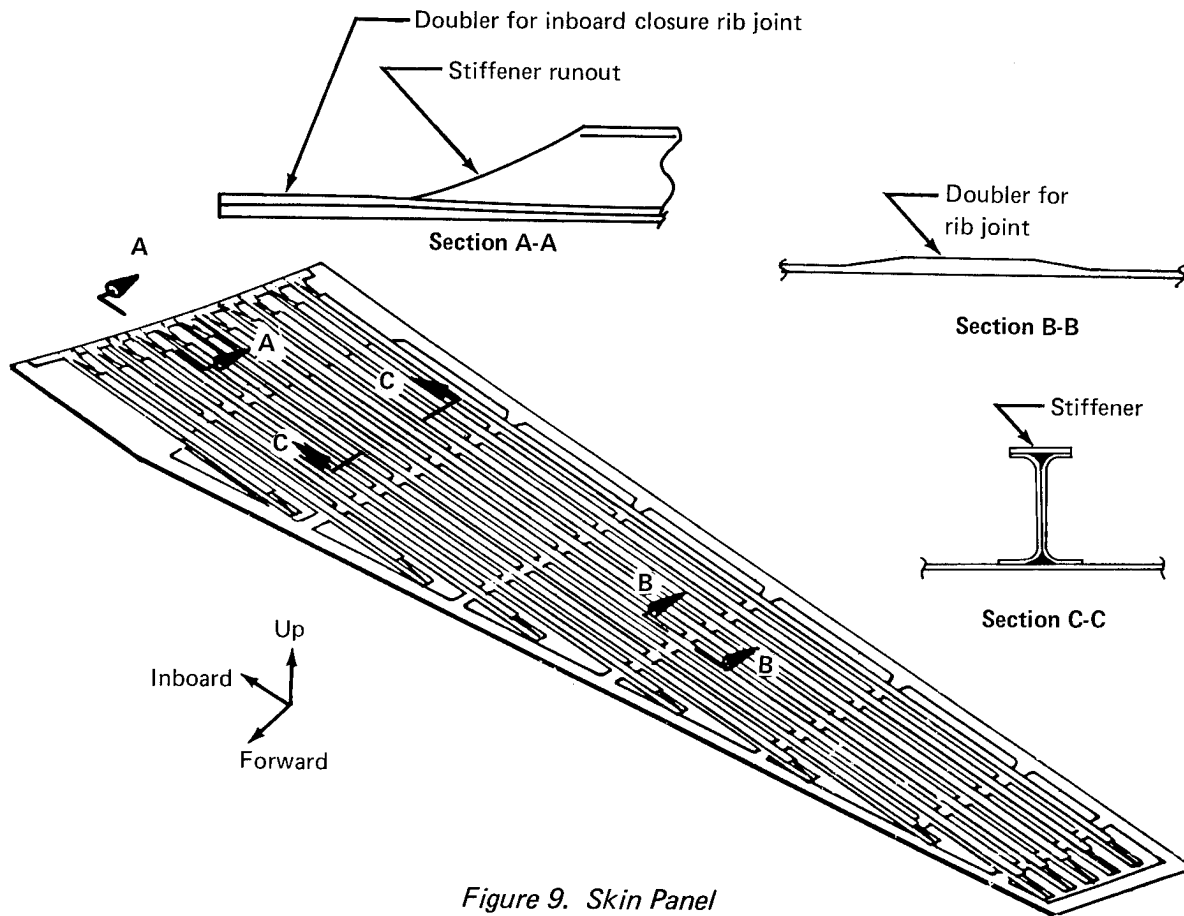

Figure 9. Skin Panel

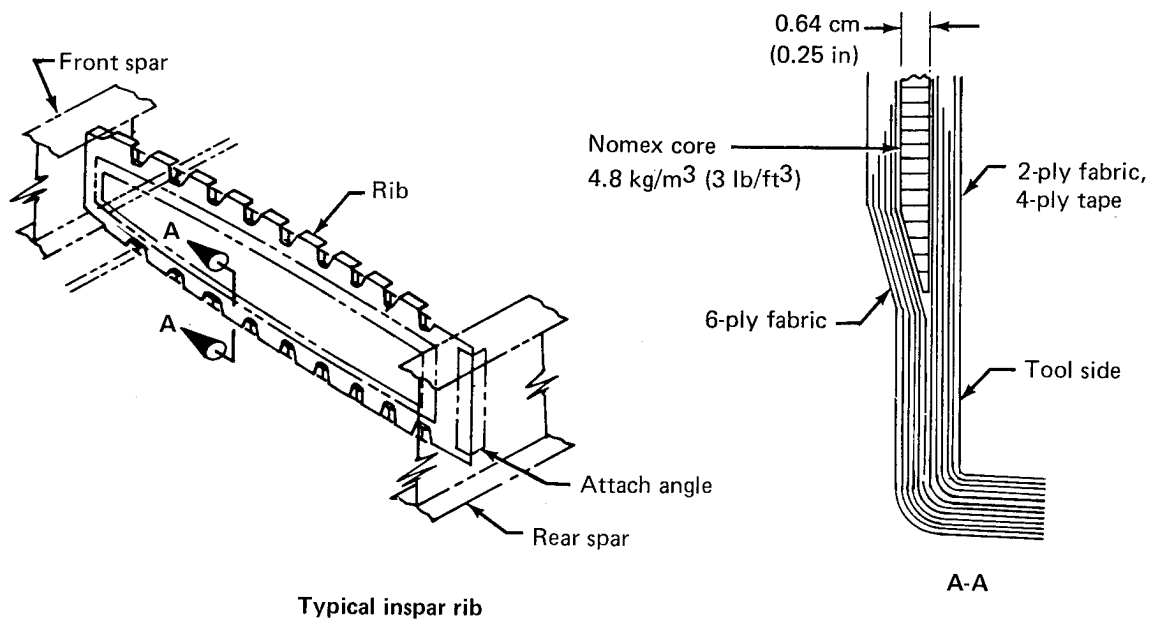

Figure 10. Typical Inspar Rib

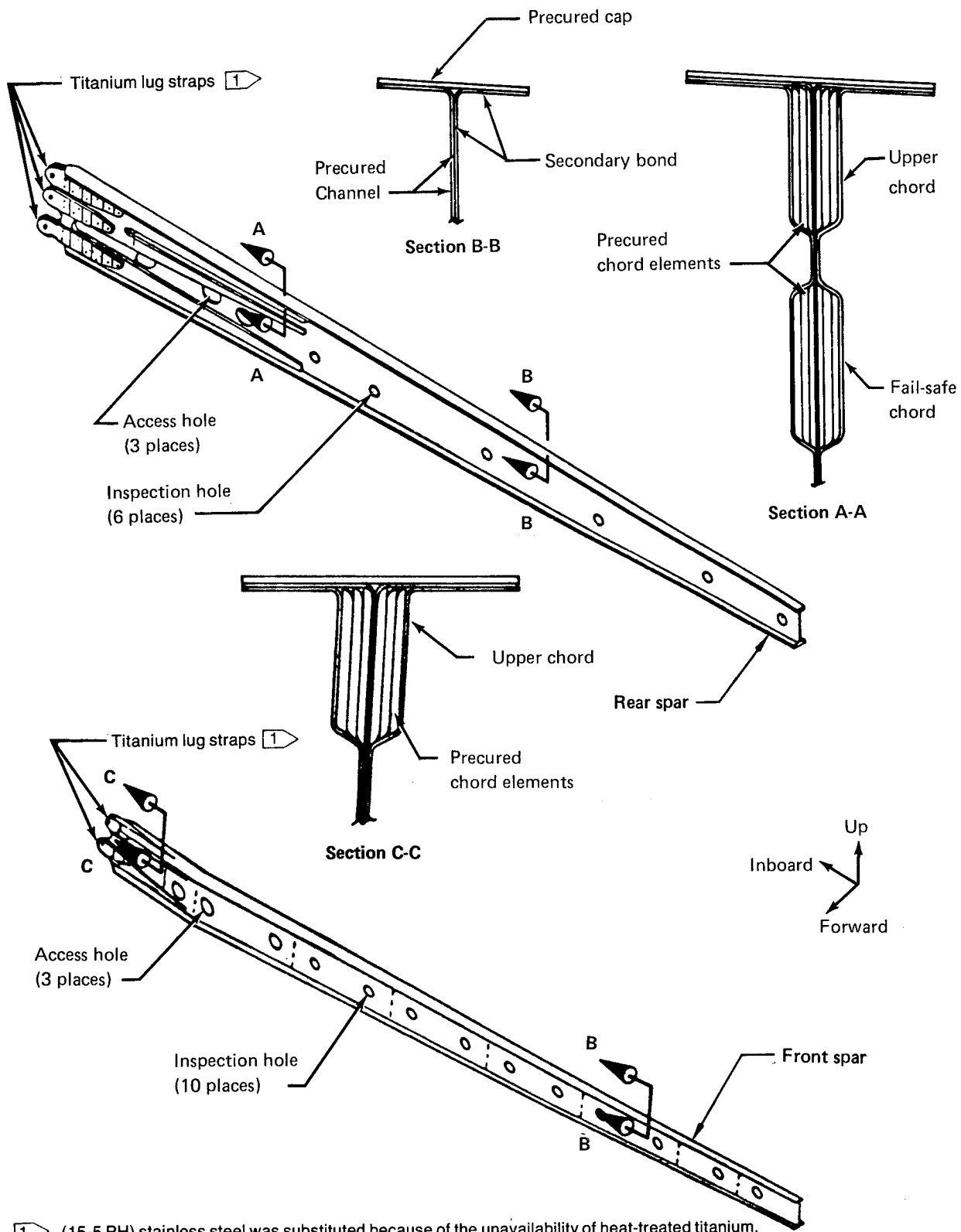

Figure 11. Front and Rear Spars

(fig. 12) was maintained by using the spar lug design concept that combined graphite-epoxy and heat-treated titanium.

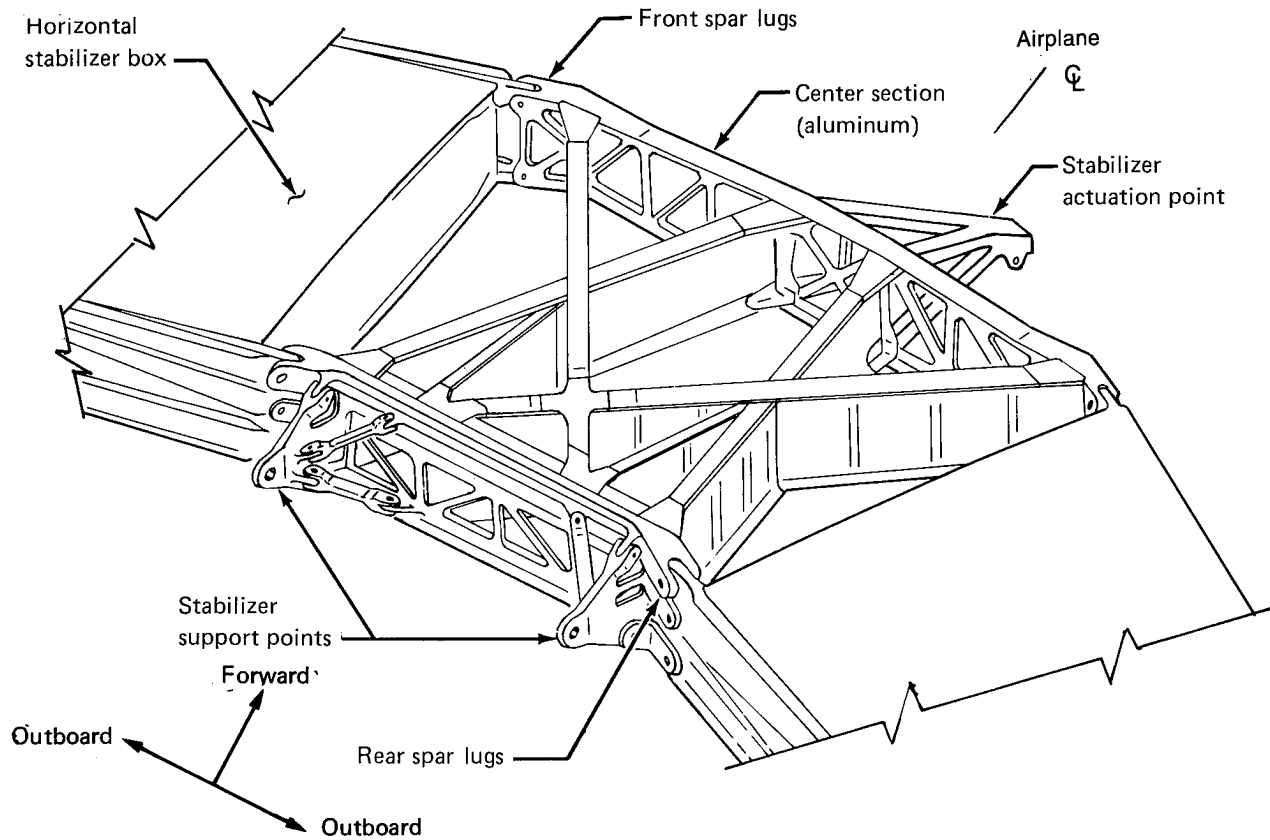

Figure 12. Center Section Interfaces

3.1.3 Environmental Protection Systems

The design incorporated protection measures for lightning, corrosion, and thermal expansion problems normally associated with graphite-epoxy structure. These protection measures include:

Lightning—The selected lightning protection system provided an electrical path around the entire perimeter of the graphite-epoxy structural box (fig. 13) and supplied a conductive coating over the graphite-epoxy structural box in the critical strike area (fig. 14).

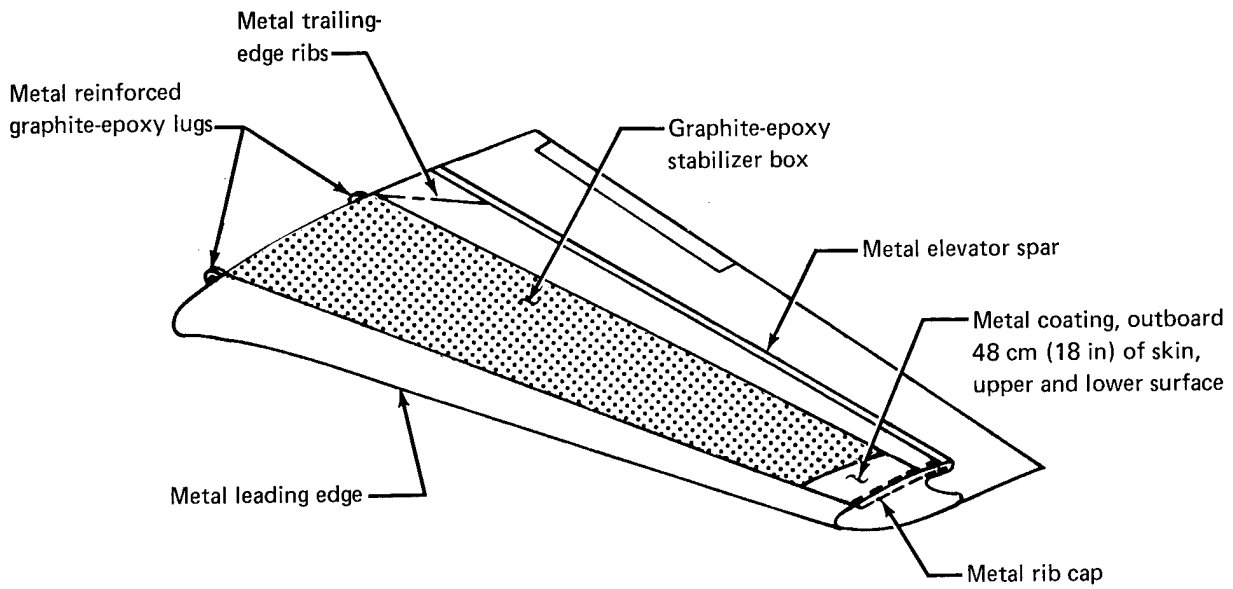

Figure 13. Stabilizer Lightning Protection

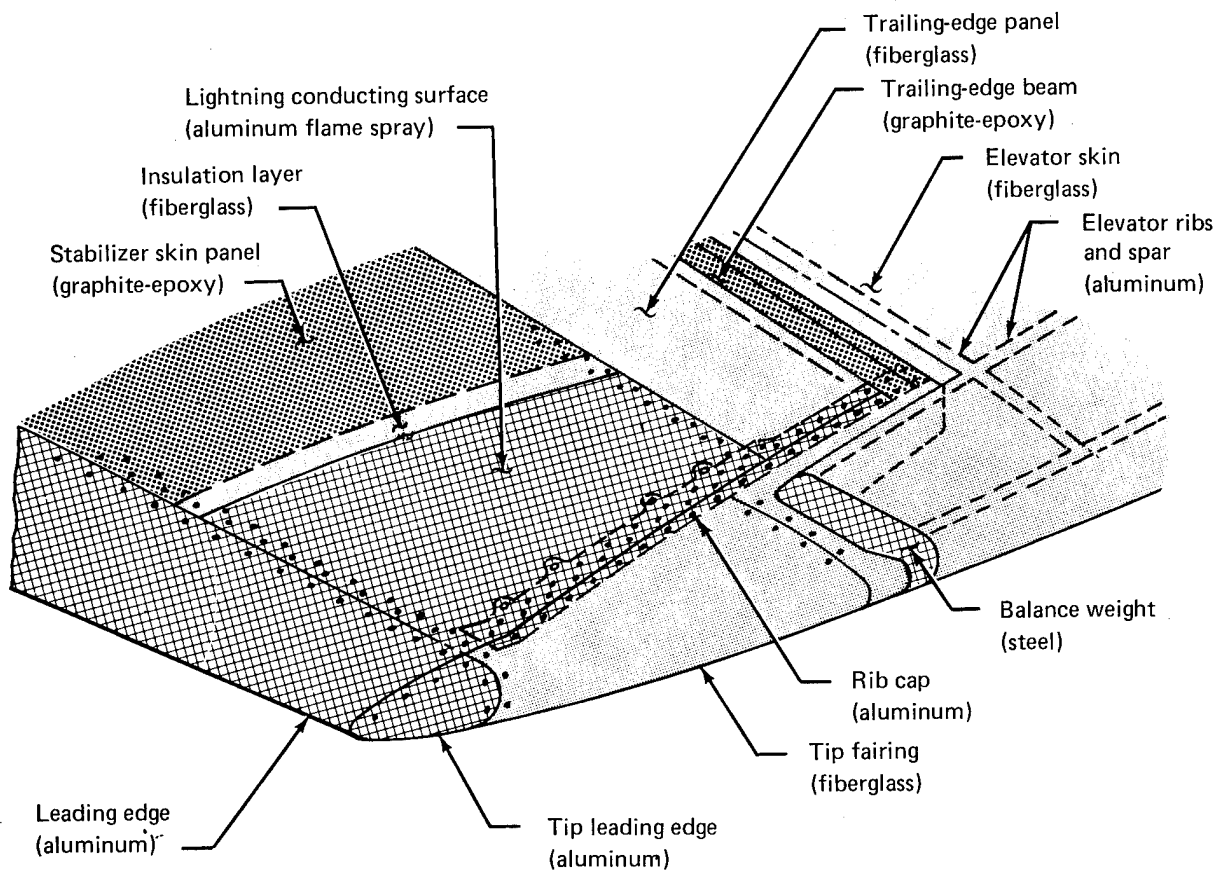

Figure 14. Lightning Protection System

The electrical path around the graphite-epoxy box was provided by the aluminum leading edge, the aluminum rib cap of the outboard closure rib, and the aluminum elevator spar. These components were electrically connected by bonding straps. The stabilizer was electrically grounded to the fuselage through the aluminum center section. The electrical path to the center section was provided through the titanium lug straps and the leading- and trailing-edge ribs.

In the critical strike area, aluminum flame-spray was applied over the outboard 48 cm (18 in) of the upper and lower skin surfaces. The conductive coating was electrically connected to the aluminum rib cap of the outboard closure rib by four mechanical fasteners and dimpled washers.

Corrosion—The corrosion protection system isolated graphite-epoxy surfaces from aluminum structure, which minimized the cathodic area (graphite) available for electrochemical reaction. This system provided corrosion protection equivalent to that of the existing baseline metal stabilizer (fig. 15). The corrosion protection system consisted of covering graphite-epoxy surfaces that interface with aluminum structure with a ply of fiberglass cocured with the graphite-epoxy or painted with primer and epoxy enamel. All graphite-epoxy surfaces that are within 7.62 cm (3 in) of aluminum, including cut edges, were primed and enameled. An exception was on surfaces where Tedlar film could be applied to the graphite-epoxy layup during cure. If the part was not painted, the cut edges were fillet sealed on assembly. In addition to the isolation of graphite-epoxy surfaces from aluminum structure, all aluminum details were anodized or alodine treated, primed, and enameled. On assembly, a polysulfide faying surface seal was applied between the graphite-epoxy part and the aluminum part. Fasteners through the aluminum part were installed with wet polysulfide sealant. In addition, all graphite-epoxy face sheets on honeycomb structure were sealed with either Tedlar film or primer and enamel to prevent moisture entrapment in the core.

Thermal Expansion—The greater thermal expansion of the existing aluminum/fiberglass elevator, in comparison to the graphite-epoxy stabilizer box, required modifications in the trailing-edge area to limit thermal stress levels and to allow for unrestricted movement of the elevator. The structural components that required attention were the elevator hinge support structure, the interfaces of the balance panels with the support structure, and the fixed trailing-edge structure (fig. 16).

The design approach was to replace the aluminum trailing-edge beam with a graphite-epoxy design. This eliminated any thermal-induced loads in the fixed trailing-edge structure. Next, a thermal compensating mechanism was designed to provide the primary load path for the elevator side load at elevator station 39.02, while allowing the elevator thermal-induced length change to be centered about elevator station 121.59 (fig. 7).

This mechanism automatically adjusted for the elevator thermal expansion by amplifying the relative movement of the aluminum strut with respect to the graphite-epoxy rear spar causing the side-load hinge fitting to rotate in unison with the elevator expansion. At elevator stations 24.90, 66.54, 176.64, and 213.32 (fig. 7), the stabilizer hinge support fittings were modified to provide a sliding bushing design. This allowed the elevator to expand without any lateral constraint.

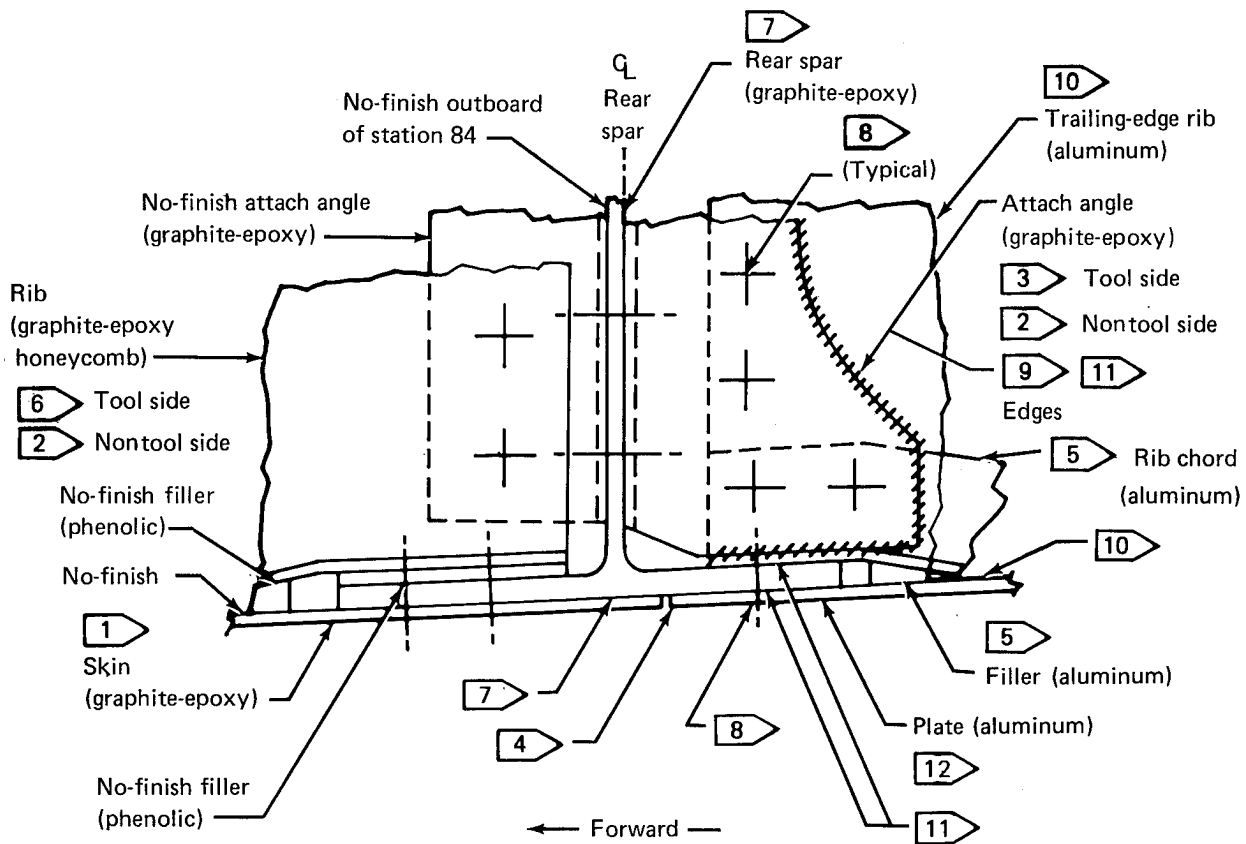

- | | |
|---|--|
| 1 Pinhole filler and surfacer + primer and polyurethane gray enamel | 7 Same as 6 except surfacer omitted |
| 2 1 ply Tedlar film (PVF) transparent 100 BG, 30 TR | 8 Wet install fastener with corrosion protection sealing |
| 3 Epoxy impregnated fiberglass fabric, type 120; cocure with graphite-epoxy | 9 Fillet seal |
| 4 Aerodynamic smoother | 10 Alodine and primer + white enamel |
| 5 Anodize and primer + white enamel | 11 Faying surface seal |
| 6 Pinhole filler and surfacer + primer and white epoxy enamel | 12 Alodine and primer + polyurethane gray enamel |

Figure 15. Corrosion Protection System

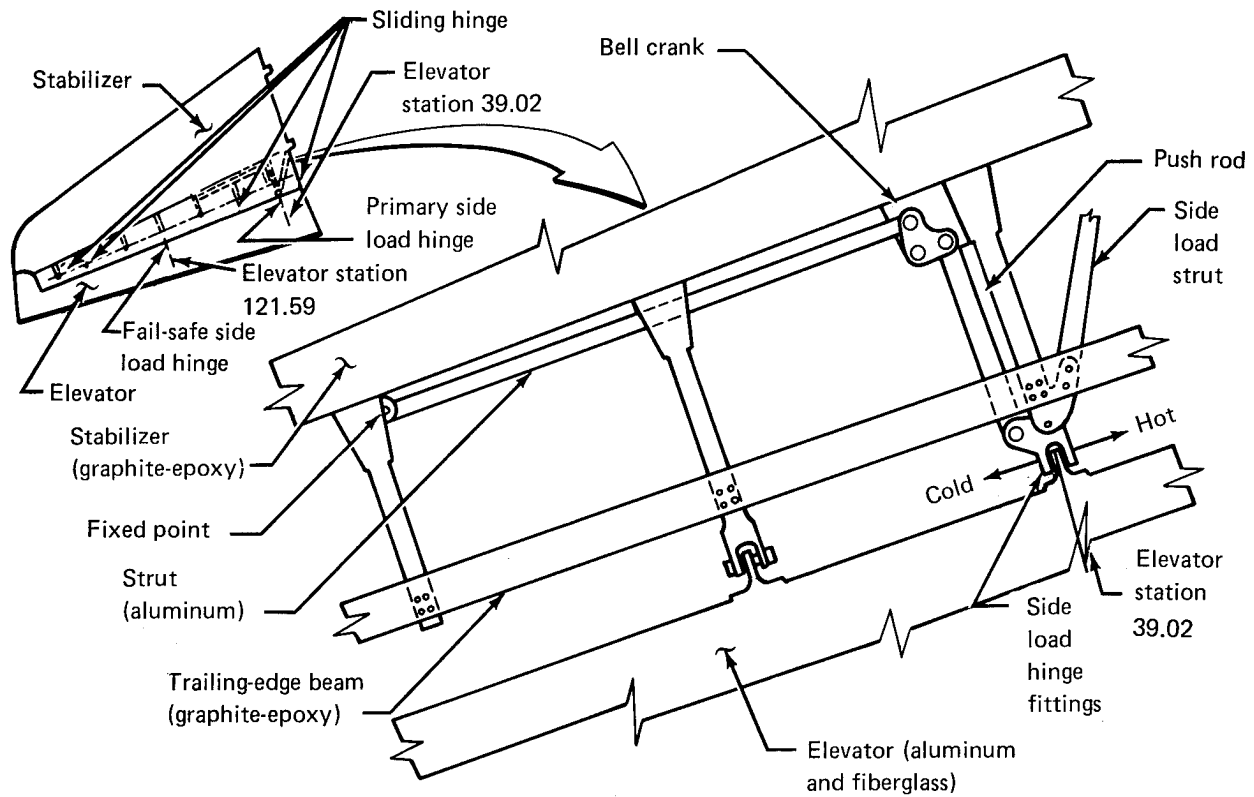

Figure 16. Thermal Compensating Mechanism

At elevator station 121.59, the existing clamped hinge design was kept to provide a fail-safe load path for the side-load condition. Because the thermal compensating mechanism keeps the elevator thermal expansions centered about this hinge location, the existing elevator has unrestricted movement regardless of the temperature changes, while existing load paths are maintained. Finally, the piano hinge attachment for the balance panels at the stabilizer interface were slotted to allow free movement of the balance panels with elevator thermal expansions.

4.0 ANALYSIS AND TEST

Detailed structural analyses and tests were performed during the program to provide the documented evidence required for certification. Thermal and moisture analyses were performed, and a finite-element model of the stabilizer was developed to determine internal loads. Tests conducted in this program included an ancillary test program, a full-scale ground test, and flight tests for flutter and stability and control. The ancillary test program contained coupon, structural-element, and subcomponent tests. Static, fatigue, and damage tolerance tests were performed with the effects of environment included. The results of these tests supported the structural analysis and provided the documented evidence for FAA certification.

4.1 ANALYSIS

4.1.1 Environmental Analysis

Analyses were performed to establish the most critical environment expected in aircraft service. A thermal analysis showed that a maximum temperature of 82°C (180°F) and a minimum temperature of -59°C (-75°F) could be expected. The results of this thermal analysis were similar to results obtained by another NASA/ACEE program (ref. 2). Moisture content studies were performed and indicated that a moisture content of 1.0% by weight could conservatively be expected in service. This result was confirmed by several studies (refs. 3 and 4). Further analysis showed that combining the 1.0% moisture content with the above temperature extremes would be a conservative means of establishing the environmental requirements. Data on the strengths of basic laminates, structural details, and subcomponents were obtained at these extreme conditions. These strength data, combined with statistically derived reduction factors, provided high-confidence design values for use in the substantiating analysis.

4.1.2 Design Values

The design values used for the final strength analysis were based on coupon or structural element test data from the ancillary test program presented in Section 4.2 of Reference 1. Average test values were reduced in a manner similar to the probability and confidence levels of MIL-HDBK-5B "B" basis; namely, that 90% of the population will be higher with a confidence of 95%. These reduction factors conservatively accounted for material strength variations, test specimen geometry variations, and test condition variations.

Material strength correction factors for each test condition were based on process control test results collected from the ancillary test specimens and analyzed to establish the strength variations. A material factor was used to correct each test point to the mean of the process panel population, and a second factor was used to correct the mean value to the required confidence level. A variation magnification factor was determined that accounted for variations in test specimen geometry, test procedure, and conditions. Coefficients of variation for every unique test condition and specimen geometry were calculated. A distribution analysis of these coefficients of variation was performed. From this distribution, the maximum variance with less than a 5% probability of exceedance was determined to be 8.1%.

The variation magnification factor then was computed as:

$$VMF = 1 - K_{B_{\infty}} v_{MAX}$$

where $k_{B_{\infty}}$ is the equivalent to "B" basis factor for an infinite sample. The v_{MAX} is the maximum variance.

Reduction factors were obtained by multiplying the three correction factors, and the final design values were obtained by multiplying the average test values by the reduction factors. The reduction factors calculated by this procedure varied from 0.70 to 0.86.

4.1.3 Finite Element Analysis

The finite element model used to obtain internal strain distributions is shown in Figure 17. The inspar box structure and the trailing-edge structure were modeled using the finite element analysis. The elevator bending stiffness was represented in the elevator hingeline beam. The stabilizer was supported on a model of the center section to provide representative stiffness load paths to the body support points. A typical strain plot is shown in Figure 18. Strains for the upper surface, lower surface, front spar, and rear spar were plotted for each flight condition. These plots were used to define the critical strain locations and magnitude for each condition. The critical strain location is at the inboard end of the rear spar. Strain levels for the critical condition are shown in Figure 18 and approach 2600 $\mu\text{in/in}$ as the maximum value. Temperature-induced strains in the stabilizer lower skin are shown in Figure 19, and 1.0% moisture-induced strains are shown in Figure 20. Flight load strains were combined with the thermal and moisture strains to establish the critical strains used in the analysis.

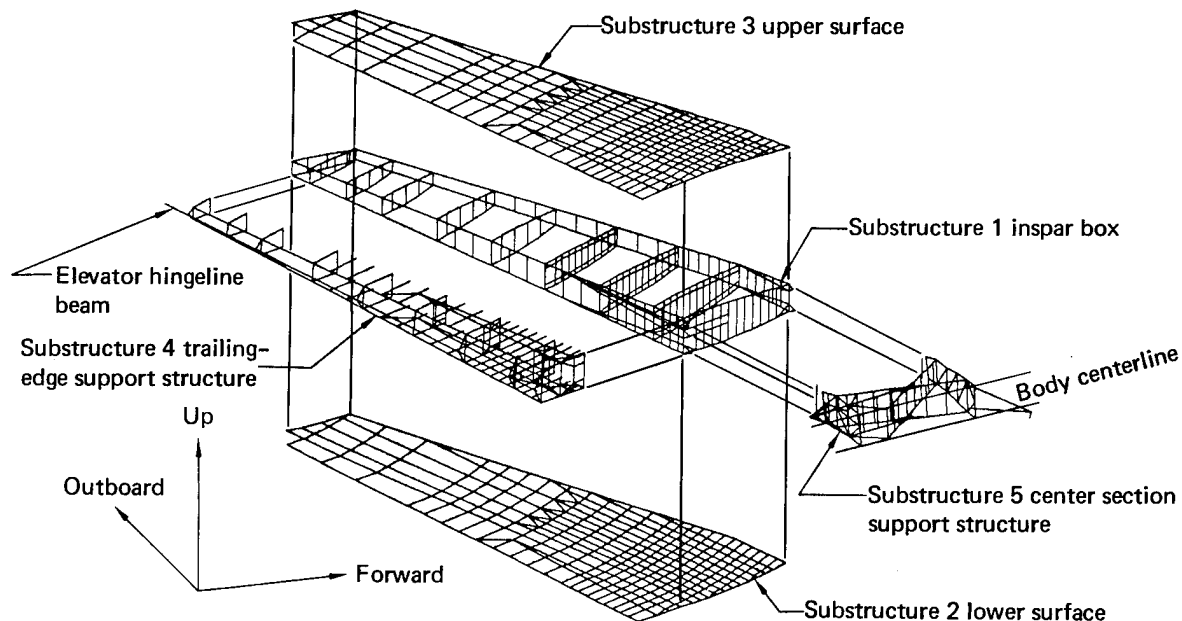

Figure 17. Finite Element Model Substructure Definition

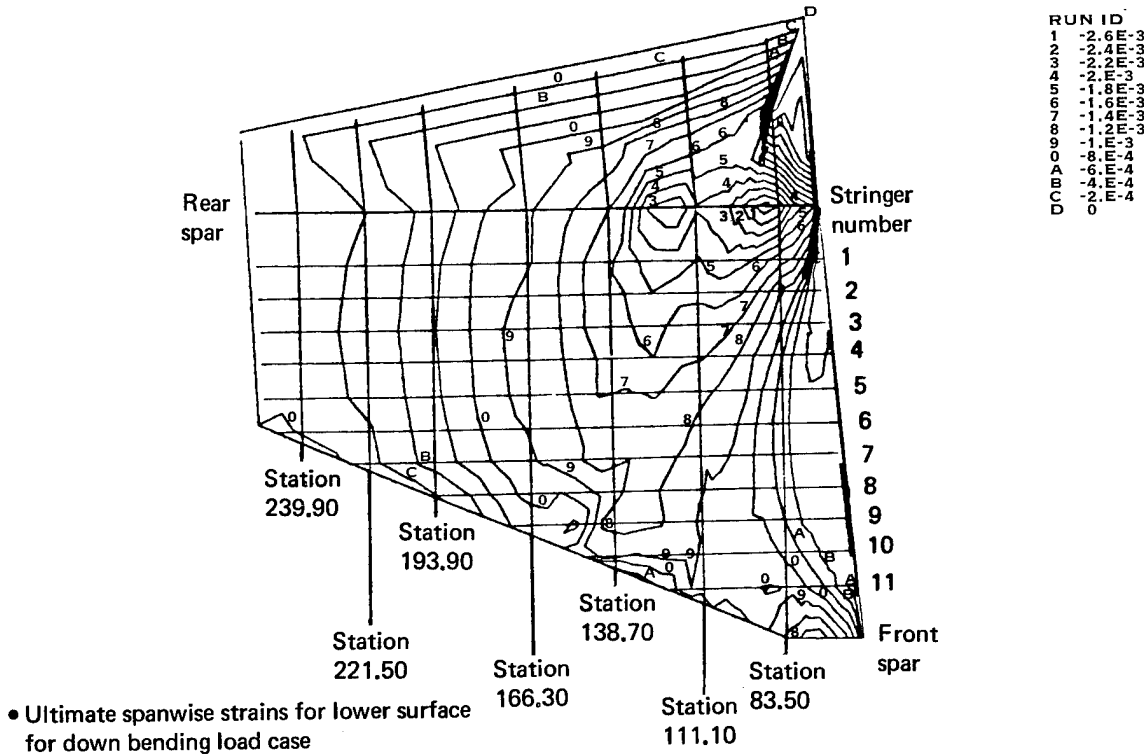

Figure 18. Example of Finite Element Analysis Model Strain Distribution

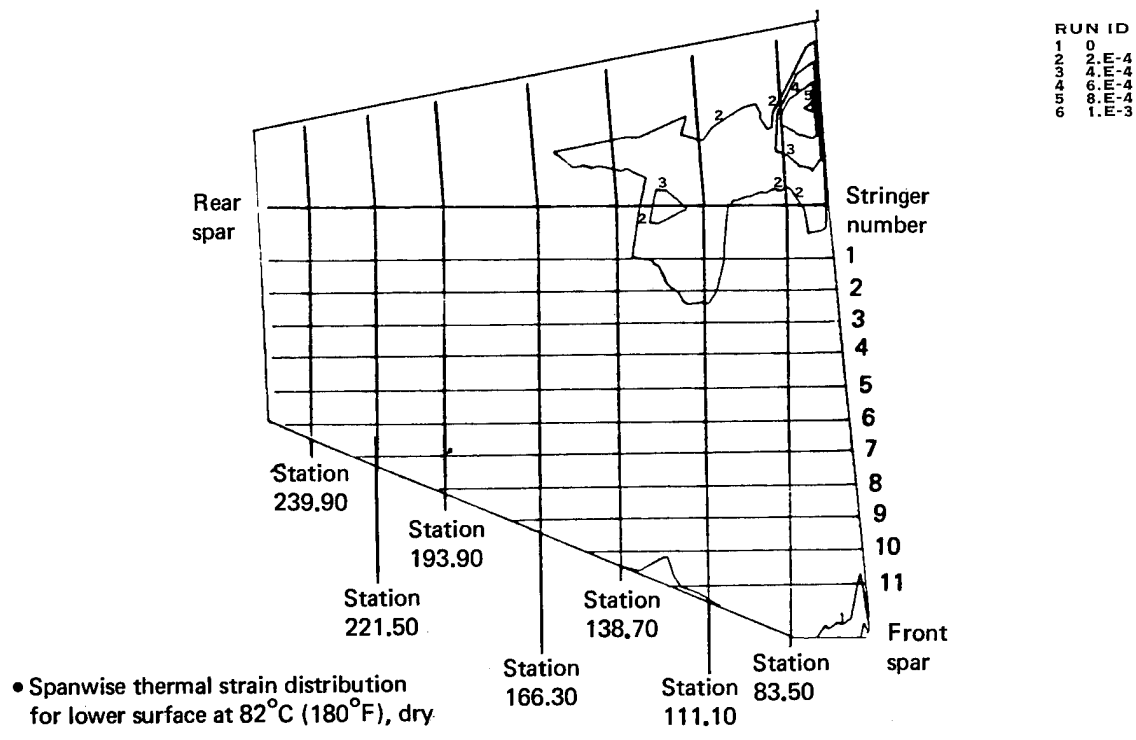

Figure 19. Example of Thermal-Induced Strains

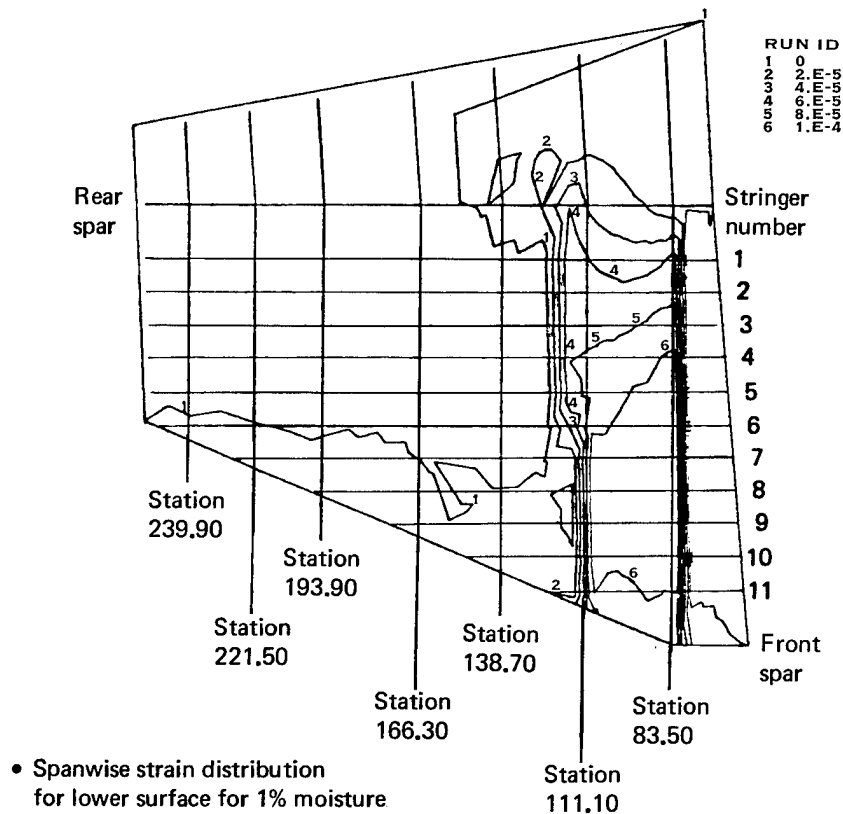

Figure 20. Example of Moisture-Induced Strains

4.1.4 Bird Strike Analysis

The composite horizontal stabilizer was required to meet the FAR 25.631 bird-strike requirements of a 3.6-kg (8-lb) bird for empennage structure. This is a new requirement since certification of the original 737 aircraft and was met by increasing the current 0.1-cm (0.04-in) thick aluminum leading edge to 0.2-cm (0.08-in) thick aluminum. This increase in gage was established by showing design similarity to the structures tested in References 5 and 6. The gage was selected to completely stop the bird at the leading edge. In addition, a large section of the supporting graphite-epoxy structure was assumed to be damaged, and the remaining structure was analyzed and shown to be adequate for the required critical loads.

4.2 ANCILLARY TESTING

The test program was tailored to provide supporting test data for compliance with FAR 25 (ref. 7) and the recommendations of the Advisory Circular (ref. 8). The testing performed in the program included an ancillary test program, a full-scale ground test, and a flight test. Full-scale ground testing and flight testing are summarized in Section 3.0 of References 9 and 10.

The ancillary test program covered coupons, structural details, structural elements, subcomponents, and a stub box test. The types of testing included static, fatigue, damage tolerance, repair, and environmental testing. The coupon, structural detail, element, and subcomponent tests including repair are shown in Figure 21.

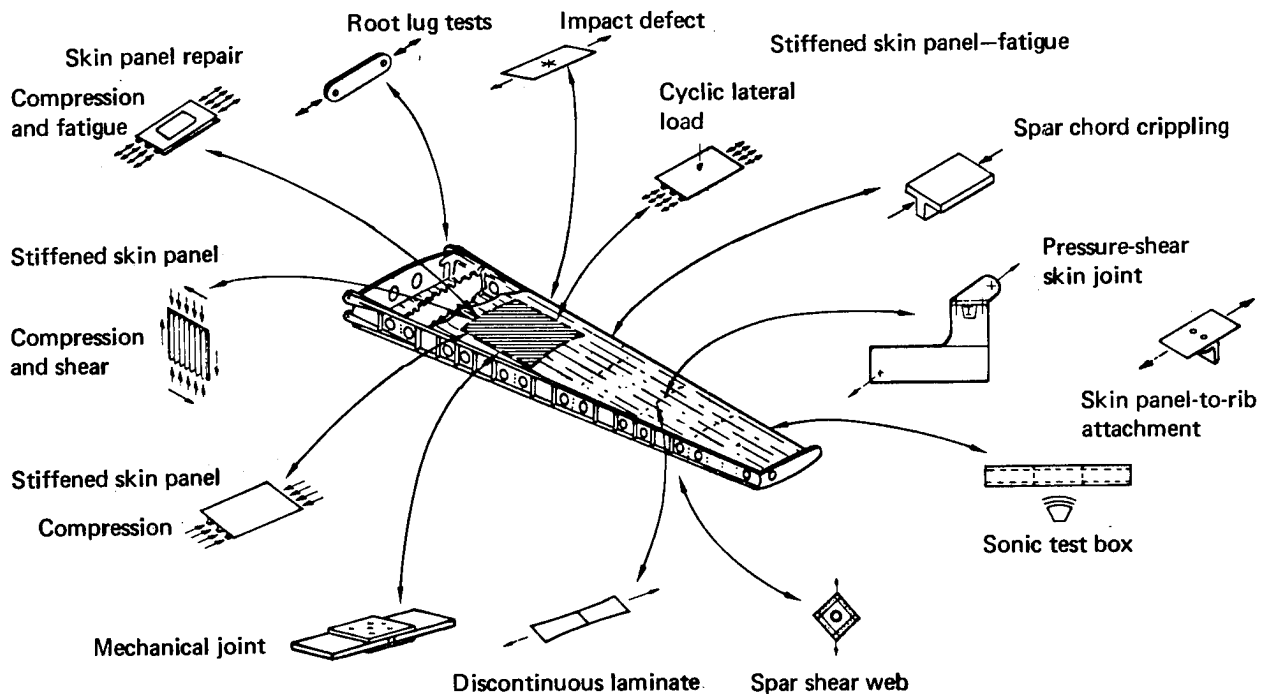

Figure 21. Ancillary Test Plan

This test plan was structured to provide:

- Material design values, including environmental effects
- Strength and fatigue performance
- Verification of final design details
- Strength and fatigue performance of repairs

Moisture conditioning of test specimens was accomplished by placing the parts in an environmental chamber at 60°C (140°F) and 100% relative humidity (RH) until 1.1% moisture level was obtained.

The stub box test, a subcomponent test of the inboard section of the stabilizer box, together with its planned test program is shown in Figure 22.

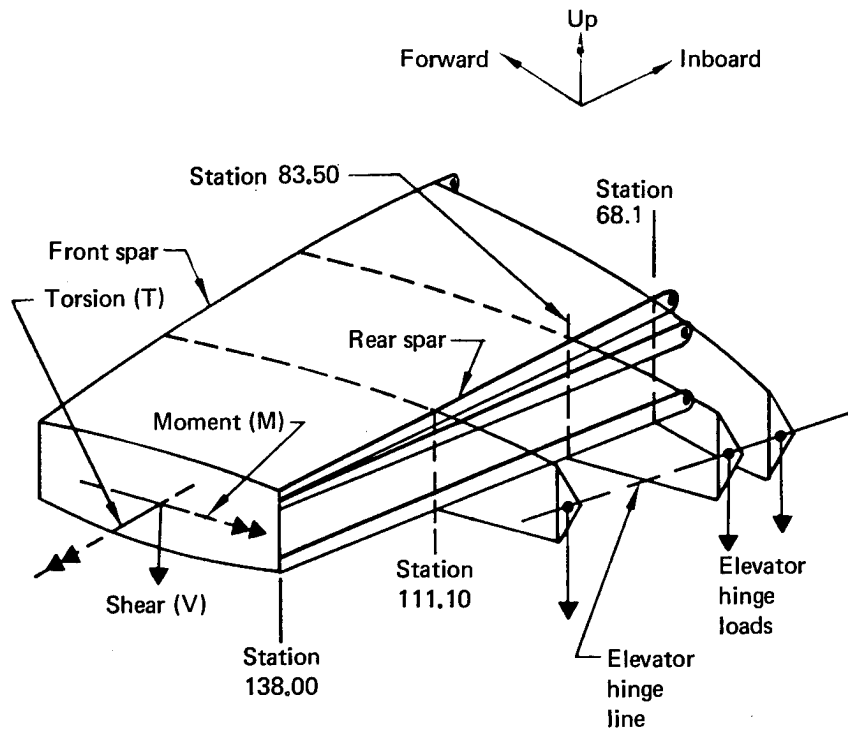

1778.0-mm (70-in) long inspar box test section









Test sequence:

- Limit load test
- One lifetime repeated loads
- Ultimate load test
- One-half lifetime repeated loads—
damage tolerance
- Damage tolerance—discrete damage
- Destruction

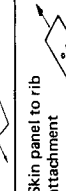
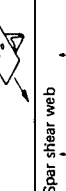
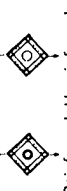
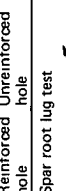
Figure 22. Stub Box Test Plan

Results from the element and structural detail ancillary test program are summarized in Table 1. Detailed test results are reported in Reference 1. Details of the damage tolerance testing were previously reported in Reference 11. The test results summarized in Table 1 together with the data from the 727 Advanced Composite Elevator Program (ref. 12) provided basic material design values, including the effects of temperature and moisture for the static strength and stiffness of the laminates and structural details used in the stabilizer. The resistance to damage growth from repeated load cycling was adequately shown for the major structural details since damage inflicted at the visible level did not propagate during spectrum loading. Residual strength capability was demonstrated for the major structural details after one lifetime of spectrum loading at critical environmental conditions. Adequate residual strength also was demonstrated for the skin panels after being damaged with simulated swept-stroke lightning. Major skin and stringer damage repair procedures were developed and verified by test. The resistance of the cocured laminate/stringer design and attachment details to sonic environment was established by subjecting these details to several lifetimes of sonic testing.

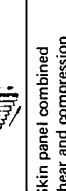
Table 1. Summary of Results of Element and Structural Detail Ancillary Test Program

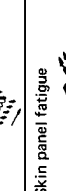
Test program	Specimen description	Results
Mechanical joints 	Single- and double-row mechanical joints in double shear with various W/D ratios 25.4 mm wide by 381.0 mm long (1.0 in by 15.0 in) to 44.5 mm wide by 381.0 mm long (1.75 in by 15.0 in) Static test	<ul style="list-style-type: none"> Obtained mechanical fastener joint strengths for full range of environmental conditions; -59°C (-75°F) to 82°C (180°F) wet
Rib clip 	Tension test of rib shear clip detail 61.5 mm wide by 228.6 mm long (2.5 in by 9.0 in) Static test	<ul style="list-style-type: none"> Obtained ultimate tension strength of detail for full range of environmental conditions; -59°C (-75°F) to 82°C (180°F) wet
Skin panel to rib attachment 	76.2 mm wide by 508.0 mm long (3.0 in by 20.0 in) segment of skin panel with rib fastener pad-up detail Static and spectrum fatigue test	<ul style="list-style-type: none"> Obtained ultimate tension strength of detail for full range of environmental conditions; -59°C (-75°F) to 82°C (180°F) wet Obtained residual strength of detail after fatigue cycling Verified no growth of visible impact damage during fatigue cycling Obtained residual strength of detail after damage and fatigue cycling
Spar shear web 	304.8 mm by 304.8 mm (12 in by 12 in) section of spar web with access hole, tested in picture-frame shear fixture Static test	<ul style="list-style-type: none"> Obtained ultimate strength of detail for full range of environmental conditions; -59°C (-75°F) to 82°C (180°F) wet
Reinforced hole 		
Unreinforced hole 		
Spar root lug test 	914.4 mm (36.0 in) long section of spar chord with lug on each end Static and spectrum fatigue test	<ul style="list-style-type: none"> Obtained ultimate strength of spar chord and lug assembly for full range of environmental conditions; -59°C (-75°F) to 82°C (180°F) wet Obtained residual strength of assembly after fatigue cycling Obtained residual strength of assembly after damage to fastener holes and delaminations after fatigue cycling
Skin panel compression 	1397.0 mm (55.0 in) long five-stringer-wide section of skin panel Static test	<ul style="list-style-type: none"> Obtained column strength of skin panel section for full range of environmental conditions; -59°C (-75°F) to 82°C (180°F) wet Verified standard Euler column analysis for panel section Obtained column strength of skin panel section after impact damage and simulated swept-stroke lightning
Skin panel shear 	762.0 mm by 762.0 mm (30.0 in by 30.0 in) section of skin panel with seven stringers tested in picture-frame shear fixture Static test	<ul style="list-style-type: none"> Obtained ultimate shear capability of skin panel section for full range of environmental conditions; -59°C (-75°F) to 82°C (180°F) wet Obtained ultimate shear capability of skin panel section after impact damage and simulated swept-stroke lightning
Skin panel combined shear and compression 	1016.0 mm by 1015.0 mm (40.0 in by 40.0 in) section of skin panel with eight stringers tested in combined load shear and compression	<ul style="list-style-type: none"> Obtained shear and compression interaction curve Obtained combined load capability after impact damage
Skin panel fatigue 	1397.0 mm (55.0 in) long four-stringer-wide section of skin panel with rib pad-up detail Tested in spectrum fatigue with lateral pressure load	<ul style="list-style-type: none"> Obtained residual strength after fatigue cycling for full range of environmental conditions; -59°C (-75°F) to 82°C (180°F) wet Verified no growth of visible impact damage during fatigue cycling Obtained residual strength after fatigue cycling and loss of 18% of load-carrying area
Sonic test box 	2032.0 mm (80.0 in) long eight-stringer-wide section of skin panel containing spar and rib attachment details	<ul style="list-style-type: none"> Verified resistance to sonic fatigue loading Verified no growth of visible impact damage during sonic test
Skin panel repair 	1397.0 mm (55.0 in) long four-stringer-wide section of skin panel with cut stringer and skin repair Compression and spectrum fatigue testing	<ul style="list-style-type: none"> Obtained column strength of skin panel with major skin and stringer repair for full range of environmental conditions; -59°C (-75°F) to 82°C (180°F) wet Obtained residual strength after fatigue cycling Verified no growth of visible damage during fatigue cycling

The stub box test program is defined in Figure 22, and the test setup is shown in Figure 23. Initial strain surveys obtained during the limit-load tests confirmed analytical predictions. One lifetime of spectrum loading was applied, and no fatigue damage was detected. Limit-load tests were repeated, and strain surveys were obtained. A comparison of the strain gage data before and after the spectrum loading showed no change in the load distribution. Discrete damage that would be visible during normal airline inspections was then inflicted in several critical areas. The structure was spectrum loaded for an additional one-half lifetime, and the discrete damage areas were inspected during this loading. None of the damage areas increased in size during this loading. Major discrete damage was inflicted on the structure in three critical areas:

- Front-spar upper chord (fig. 24)
- Lower surface stringer 2 and two skin bays (fig. 25)
- Rear-spar lower chord (fig. 26)

The box was loaded to the critical fail-safe load levels for each area. For each of the three damage sites, the fail-safe load levels were successfully achieved.

By testing the critical structure early in the program, the following advantages were gained:

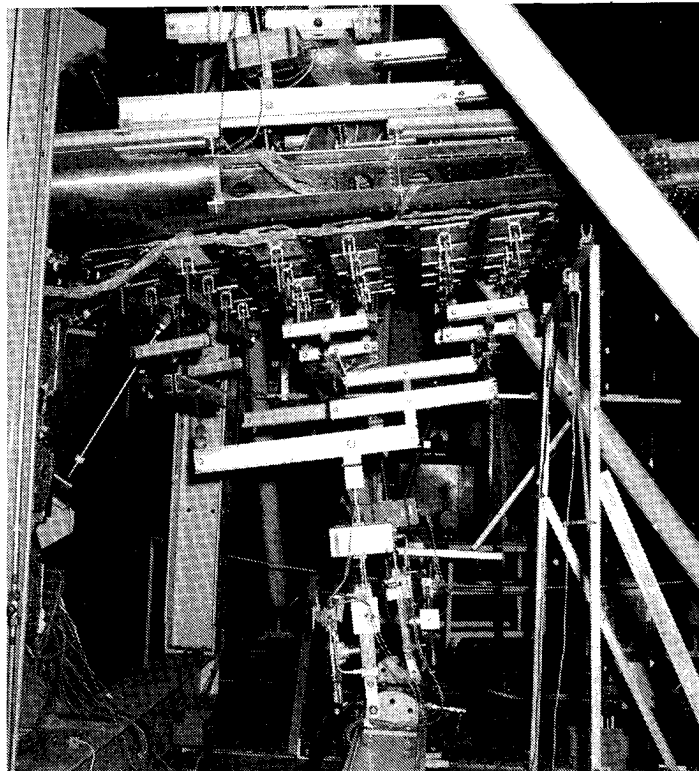

Figure 23. Stub Box Test Setup

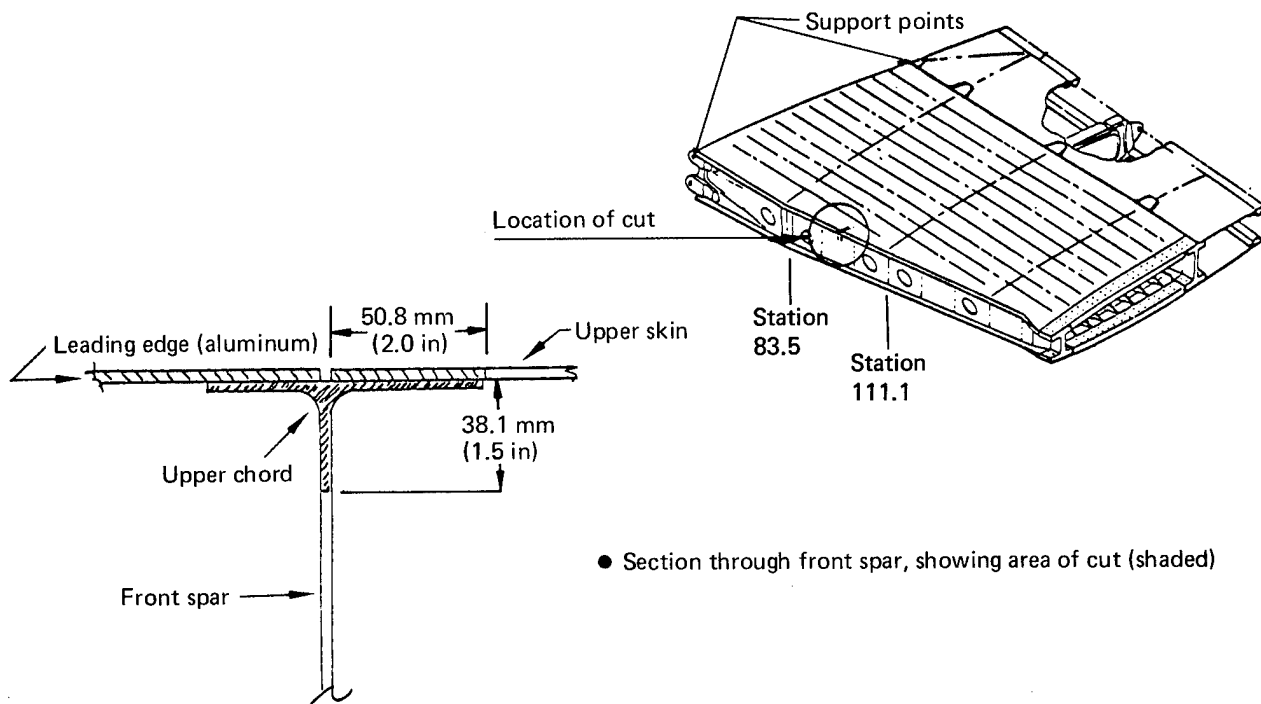

Figure 24. Stub Box Damage Tolerance Test—Front-Spar Upper Chord, Skin, and Leading Edge

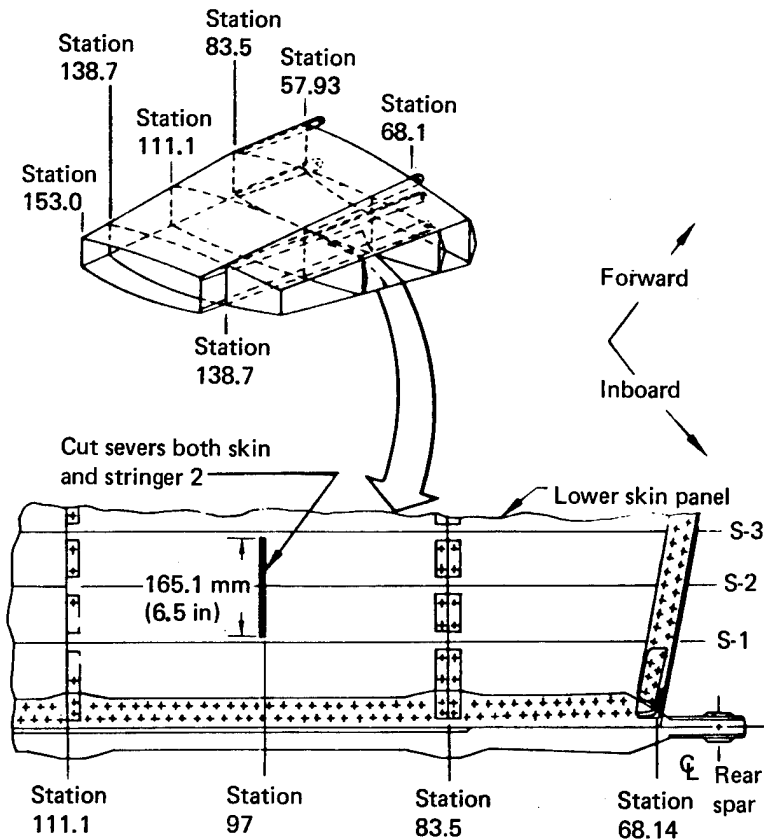

Figure 25. Stub Box Damage Tolerance Test—Lower Surface Skin and Stringer

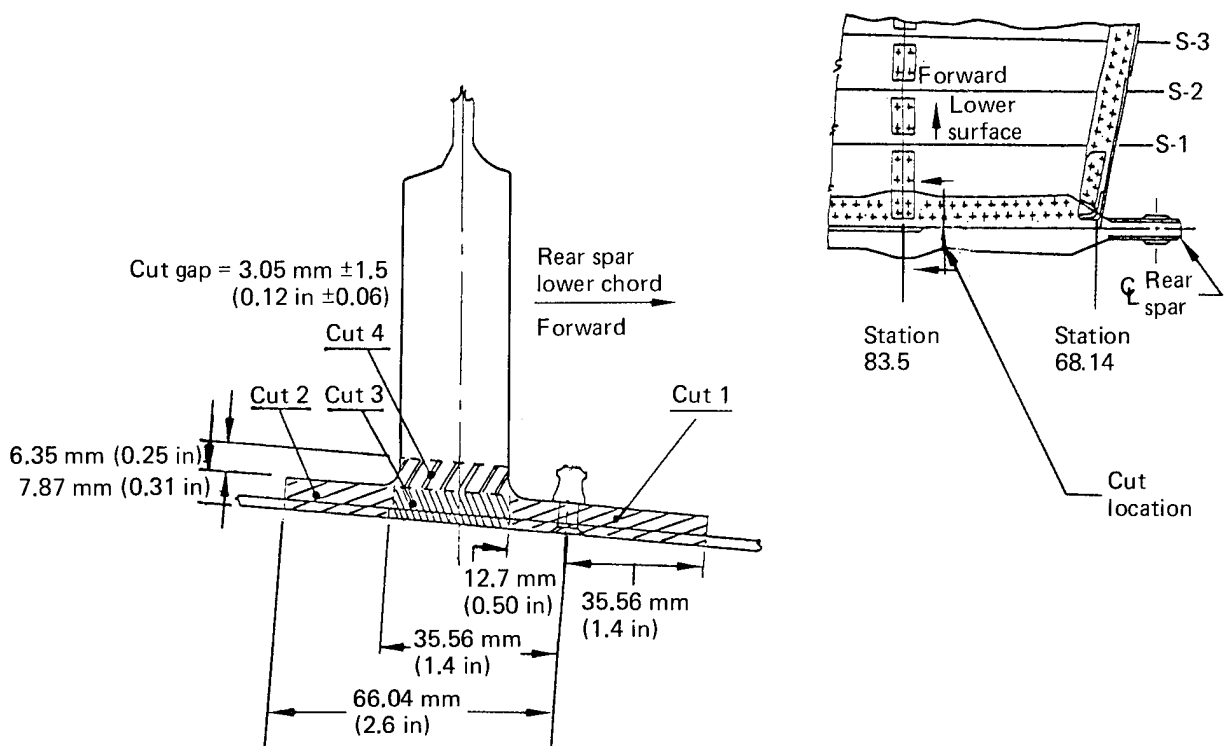

Figure 26. Stub Box Damage Tolerance Test—Rear-Spar and Lower Chord

- Identified modifications to design of the rear spar lugs with minimum impact on production structure and schedule
- Verified structural load paths
- Verified the finite element model
- Data support for the "no-growth" damage tolerance philosophy

4.3 ENVIRONMENTAL TEST PANEL

As part of the stabilizer certification program, an environmental test panel was tested to demonstrate:

- The effects of moisture and temperature on the strain distributions of a highly loaded structure
- The capability of the critically loaded graphite-epoxy structure to withstand limit and ultimate loads under hot-wet and cold-dry conditions
- The capability to predict the effects of moisture and temperature extremes by analysis

A panel that represented a segment of the stabilizer lower skin and rear spar was tested in a combined-load fixture to produce the same strain distribution as the full-scale box. The panel was tested at 21°C (70°F), -59°C (-75°F), and (after exposure to moisture) at 82°C (180°F). The panel test setup is shown in Figure 27. A photograph of the test panel is shown in Figure 28.

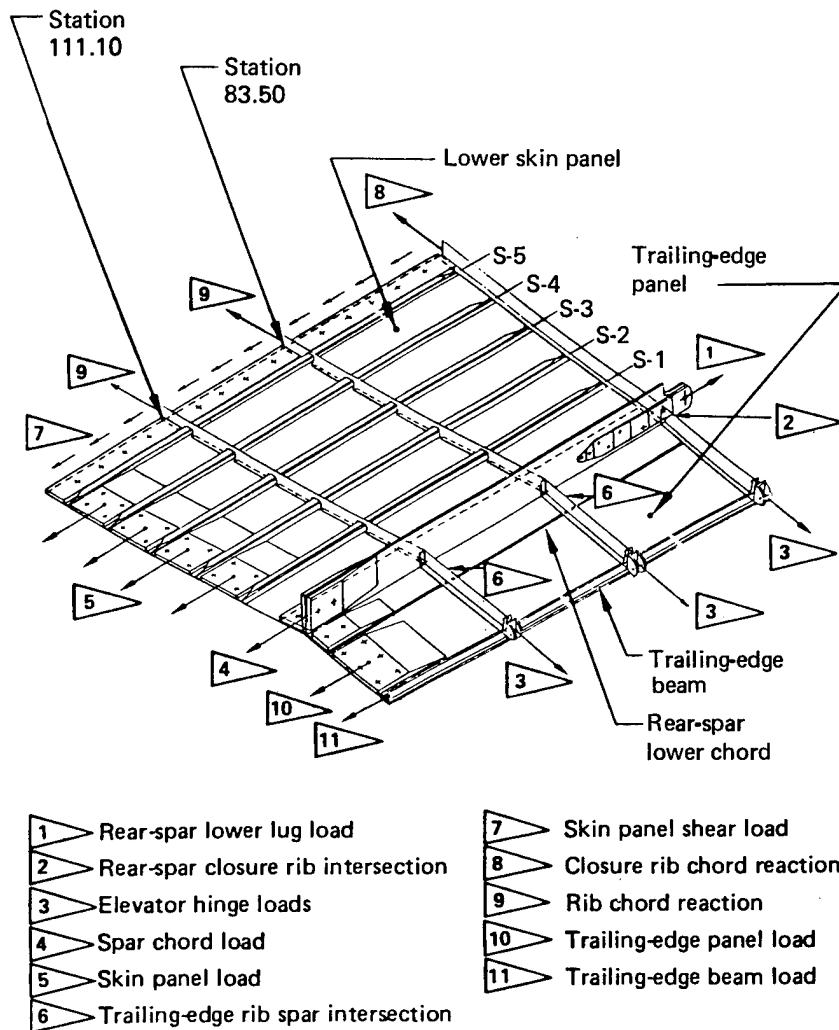

Figure 27. Stabilizer Rear-Spar Lower Chord and Skin

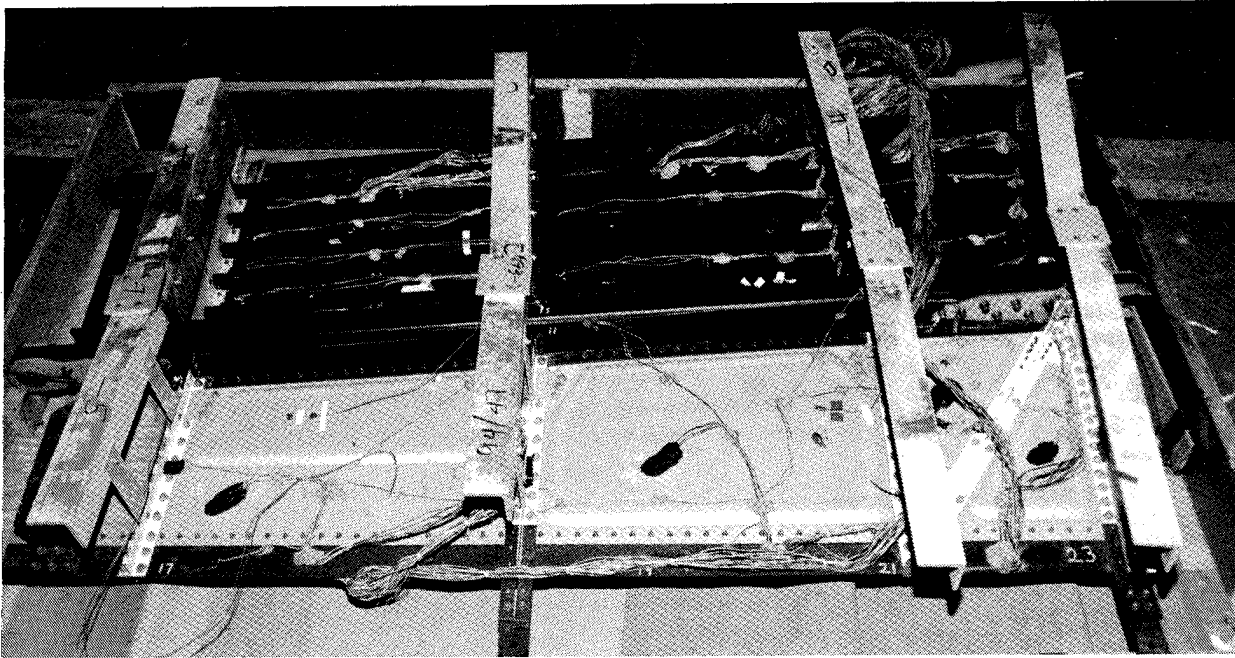

Figure 28. Environmental Test Panel

A comparison between predicted and measured strains is shown in Figure 29 for the gage located at station 83.5 on stringer 1. Close agreement was obtained for all three test conditions. The degree of correlation obtained validated the analytical approach of algebraically adding together the strains caused by the applied load and the thermal and moisture environment. The panel was loaded to the design-ultimate load at the 82°C (180°F) wet environmental condition, and no failures occurred at this load level. Loading was continued and the panel failed at 137% of design-ultimate load by shear-out of the metal lug plates. This load level was similar to that previously achieved by the lug subcomponent test specimens.

4.4 WEIGHTS

Only the inspar primary box structure of the horizontal stabilizer, which was redesigned using graphite-epoxy material, is evaluated for weight reduction. Initial weight evaluation of the graphite-epoxy structure shown in Table 2 was developed using preliminary design information and layout drawings. These data were updated using finite element information and the stub box test component drawings to represent the production structure; the stub box design then was extrapolated to the full-size structure. This revision resulted in a weight increase of 7.5 kg (16.6 lb).

The initial weight comparison between the graphite-epoxy structure and the existing aluminum structure showed a reduction of 29%. After incorporating the stub box design revision, a weight reduction of 27% resulted. For production weight data analysis, see Section 3.5 of References 9 and 10.

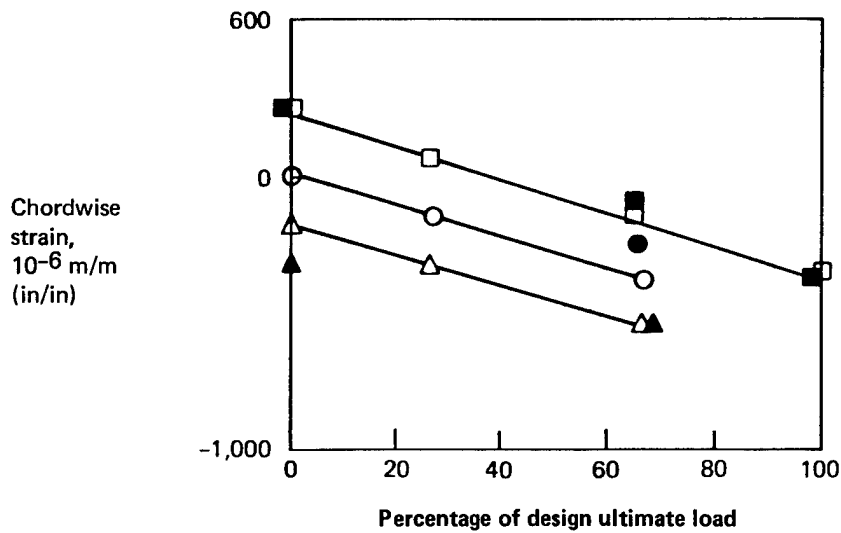
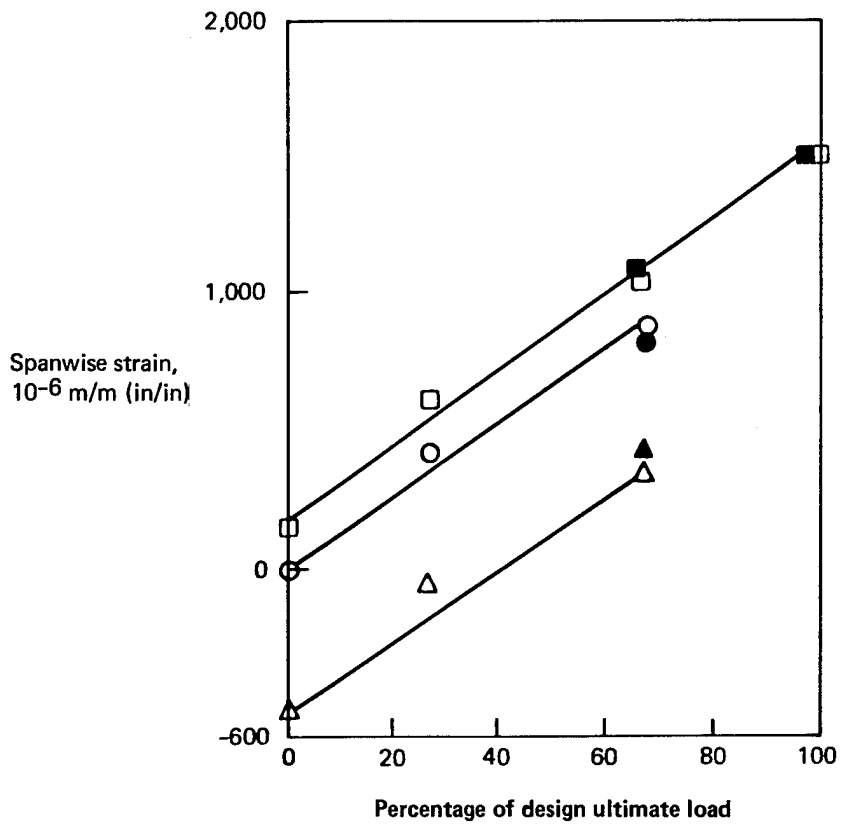

Test location: Stringer 1 at station 83.5 rib	21°C (70°F), ambient dry	○	●
	-59°C (-75°F), dry	△	▲
	82°C (180°F), wet	□	■
		Test	Prediction

Figure 29. Comparison of Strain Gage and Analytical Model Prediction for Environmental Panel Test

Table 2. Composite Stabilizer Inspar Structure Weight Comparison

Horizontal stabilizer—737	Metal design weight kg (lb)/airplane	Composite design weight kg (lb)/airplane	Weight reduction kg (lb)/airplane	Percent change
Front spar	31.3 (69.0)	20.2 (44.6)	-11.1 (-24.4)	-35.0
Rear spar	71.2 (156.9)	42.9 (94.6)	-28.3 (-62.3)	-40.0
Skins	72.3 (159.5)	71.8 (158.3)	-0.5 (-1.2)	-0.7
Ribs	60.9 (134.2)	30.3 (66.8)	-30.6 (-67.4)	-23.0
Access doors	0.7 (1.6)	0.9 (2.1)	+0.2 (+0.5)	+28.0
Total stabilizer inspar structure/ airplane	236.4 (521.2)	166.1 (366.4)	-70.3 (-154.8)	-29.0

5.0 FABRICATION DEVELOPMENT

Design and stress engineers worked with manufacturing and quality control engineers to develop manufacturing and tooling techniques for the 737 composite horizontal stabilizer. They also established producibility and costs of various design concepts. This team effort led to development of the fabrication methods used to produce five-and-one-half stabilizer shipsets.

5.1 TRADE AND PRODUCIBILITY STUDIES

These studies determined the relative cost and difficulty of producing specific parts with varied design concepts, using different types of materials and/or refined tooling. The following composite parts were studied:

- I-Stiffened Panel.** This study compared cost and producibility for this design of stabilizer panel using woven fabric or, alternatively, prepreg unidirectional tape in the I-channel sections (fig. 30). The woven fabric, which required 36% less fabrication labor, was the most economical fabrication material. Tooling and manufacturing procedures were developed to ensure accurate stiffener alignment and spacing (figs. 31 and 32).

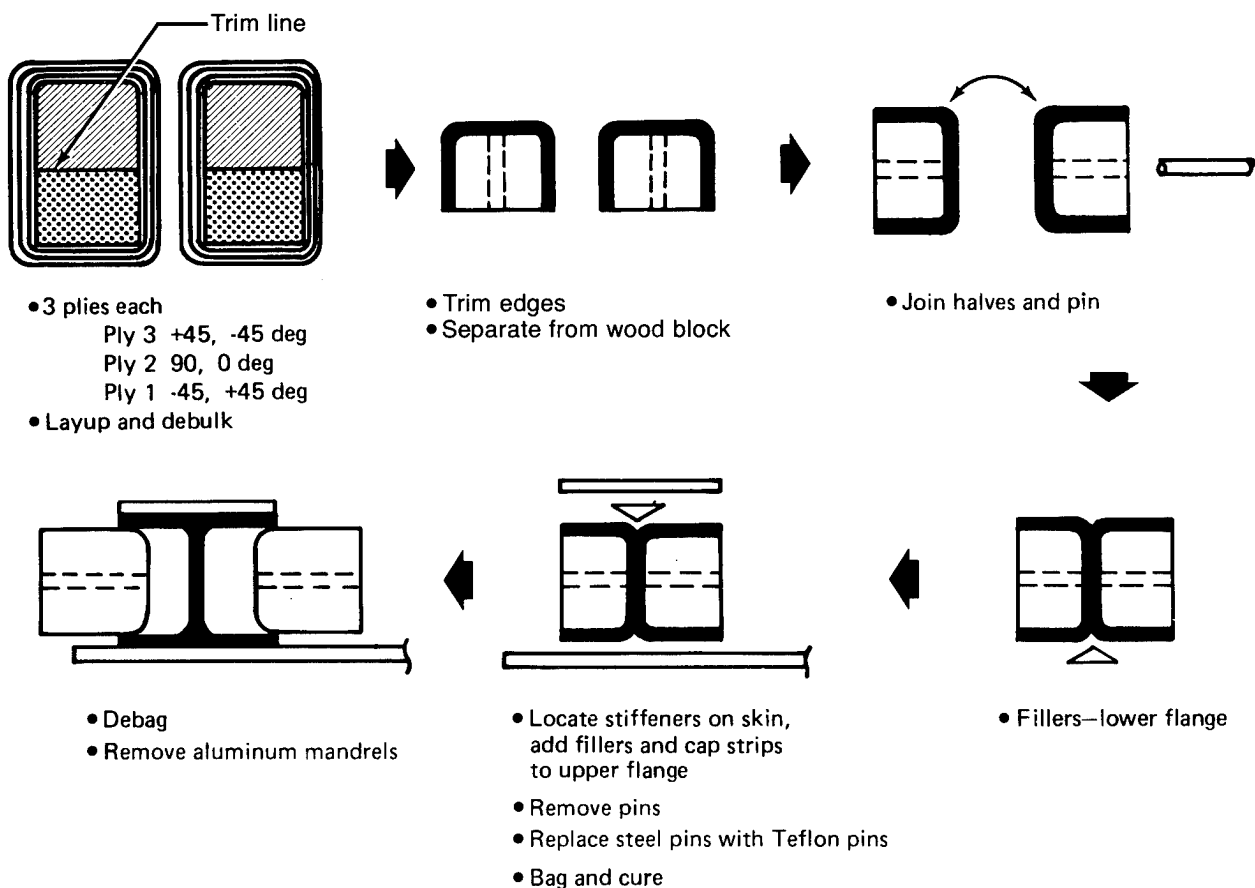

Figure 30. Layup of I-Section Stiffeners

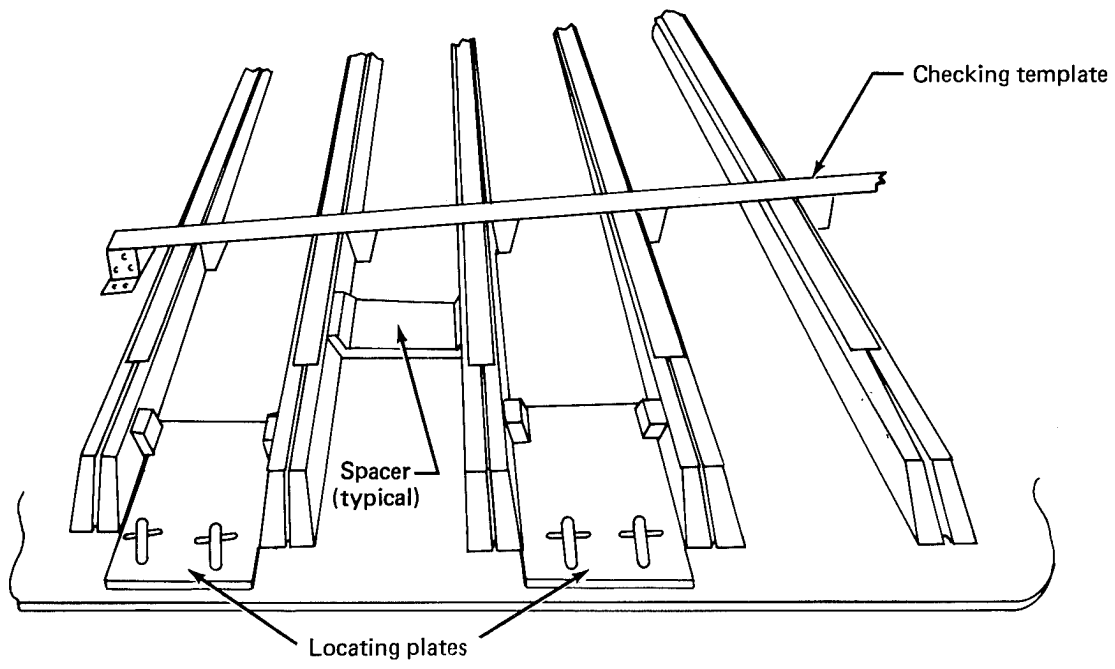

Figure 31. I-Stiffened Panel Tooling Approach

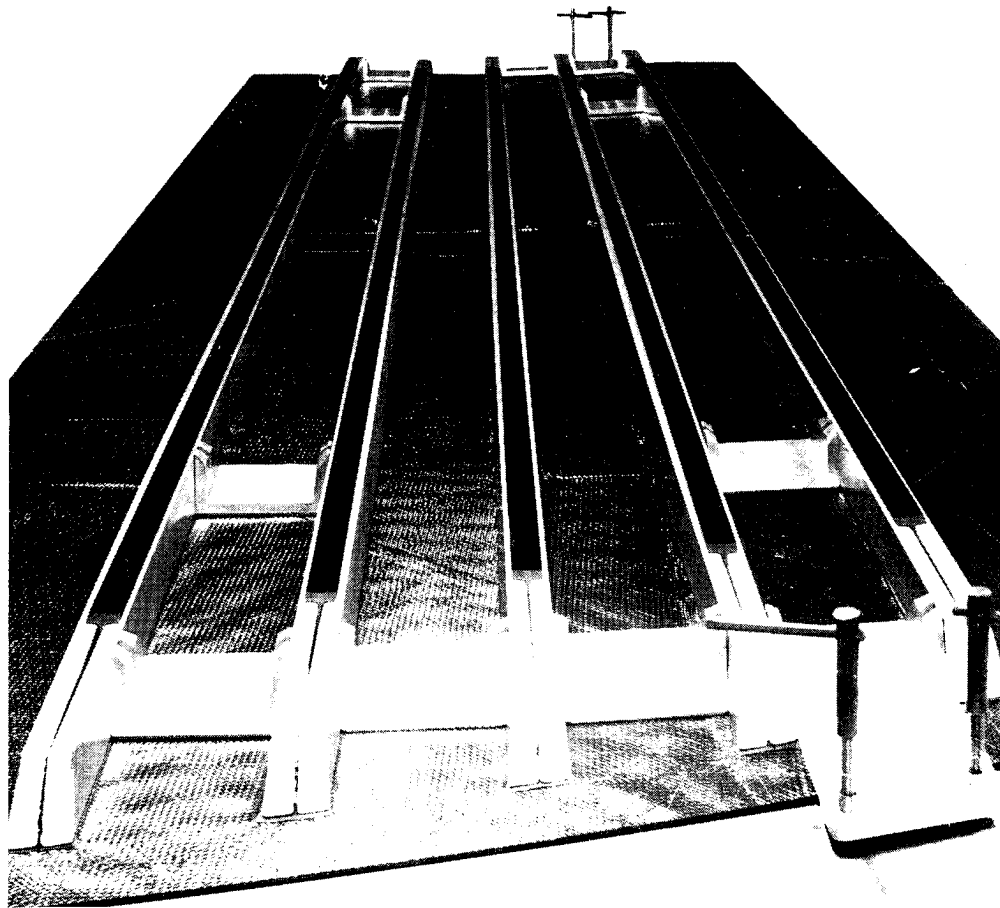

Figure 32. Tool Concept of I-Section Stiffeners

- **Inspar Rib Trade Study.** The cost of the corrugated rib design was found to be 2.1 times greater than the cost of the honeycomb rib design that was selected (figs. 33 and 34).
- **Spar Lug Fabrication.** Three spar attach lug designs, shown in Figure 35, were fabricated and nondestructively inspected. This inspection showed that integrity of the bond in the bolted and bonded strap was significantly greater than that of the strap that was only bonded. In addition, labor cost of the bolted and bonded design was one-third that of the all-graphite design.

5.2 ANCILLARY TEST COMPONENT FABRICATION

The ancillary test coupons, elements and assemblies (figs. 36 through 41) were manufactured in a production environment using materials and processes described in standard specifications. These parts were tested to determine material design values and establish concept validity as described in Section 4.2.

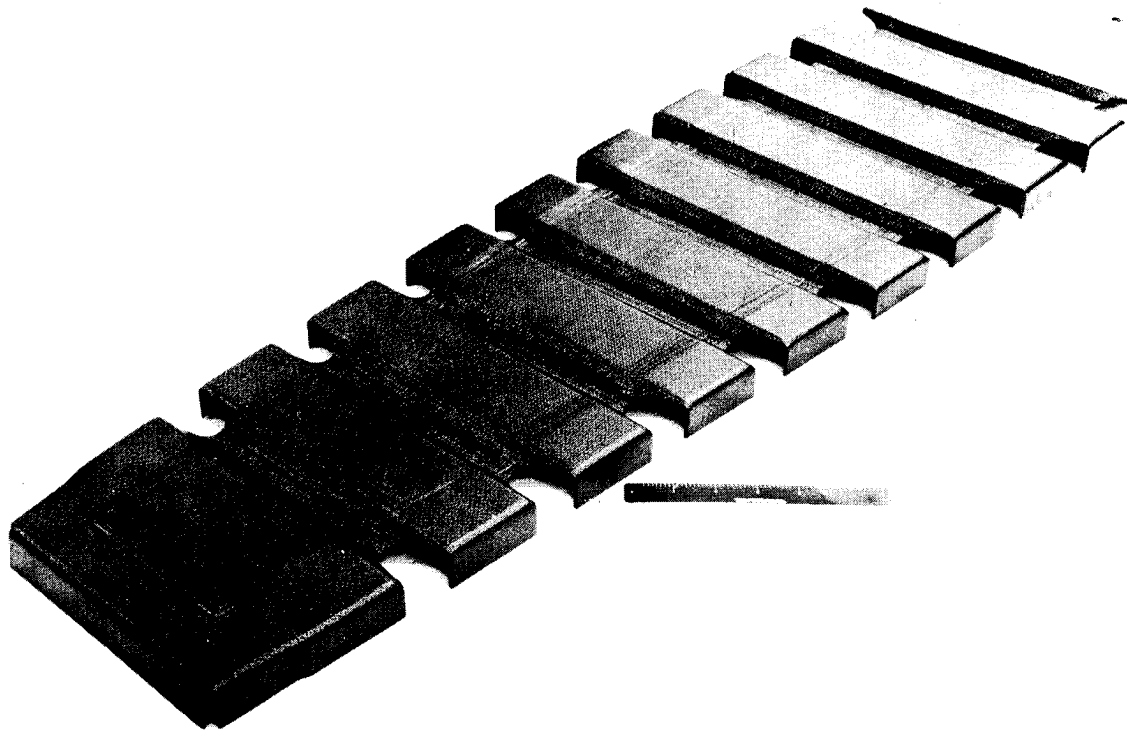

Figure 33. Corrugated Inspar Rib

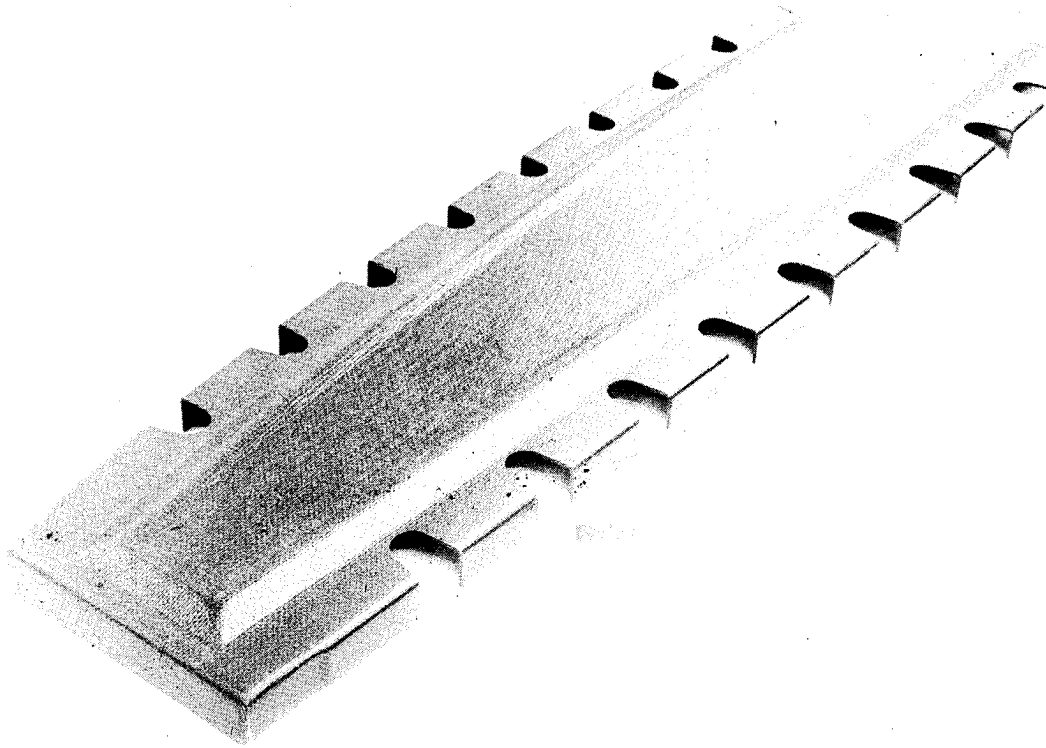
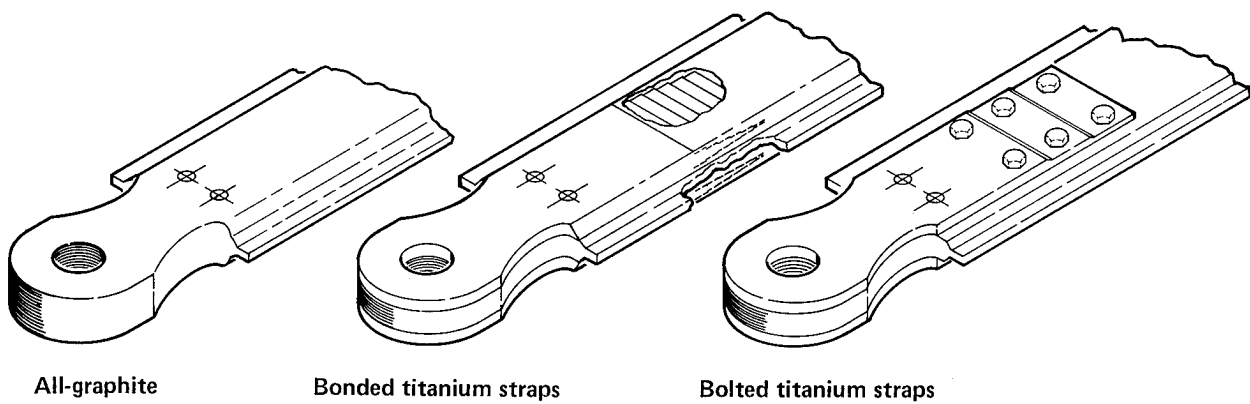

Figure 34. Honeycomb Inspar Rib



All-graphite

Bonded titanium straps

Bolted titanium straps

Figure 35. Spar Lug Concepts

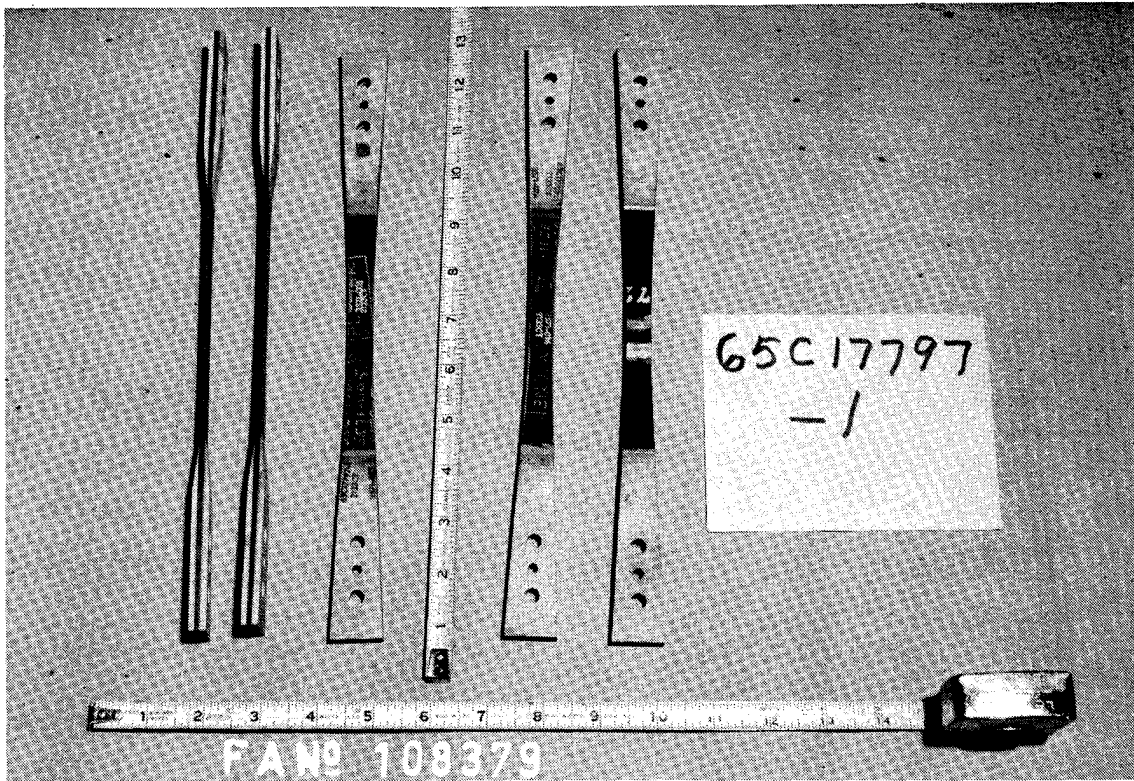

Figure 36. Ancillary Test—Typical Tensile Specimens

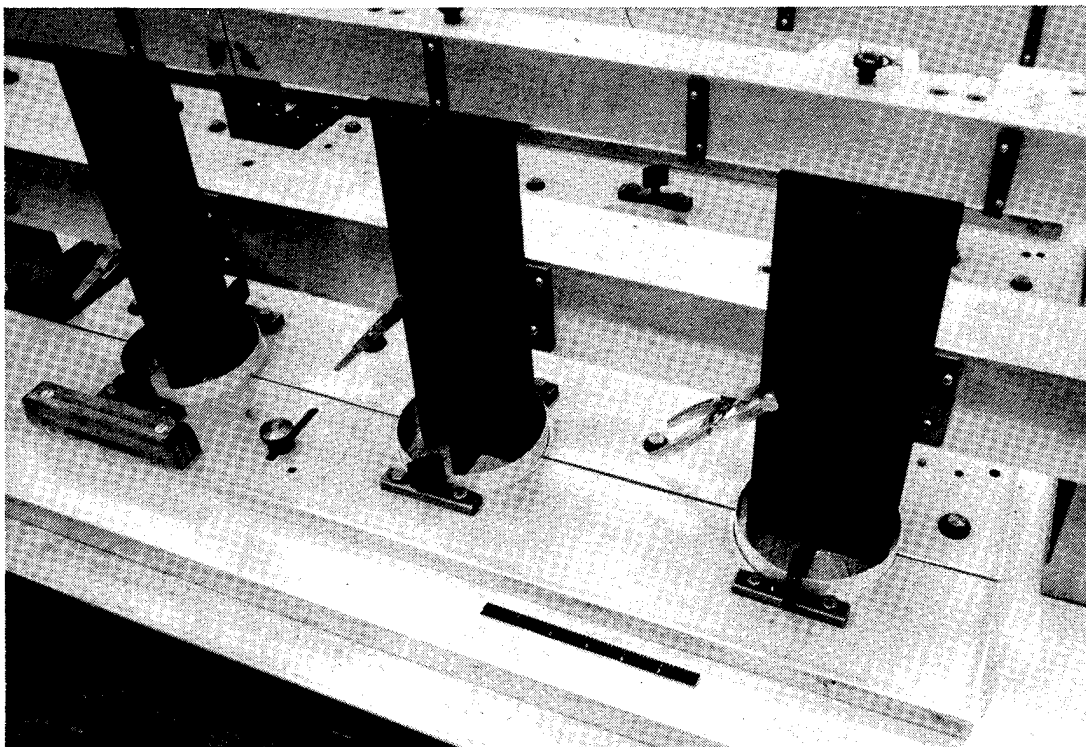

Figure 37. Spar Chord Crippling—Specimen Ready for End Potting

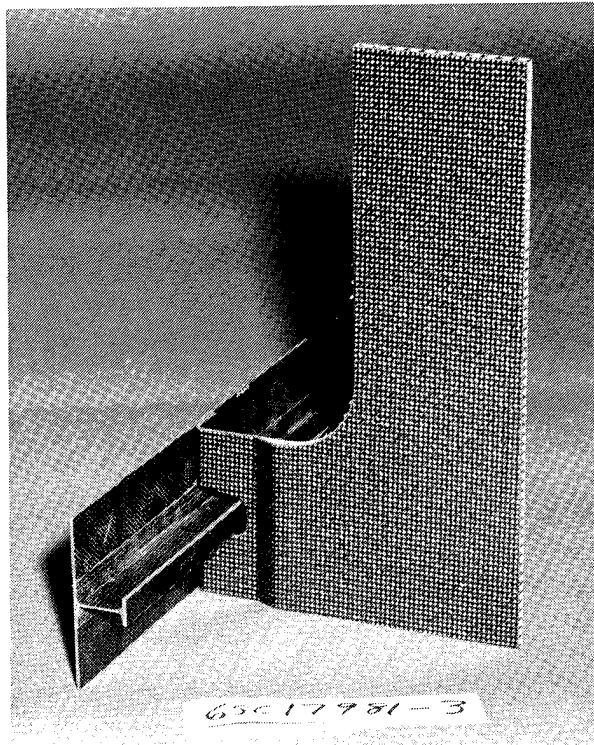

Figure 38. Panel-to-Rib Joint Test

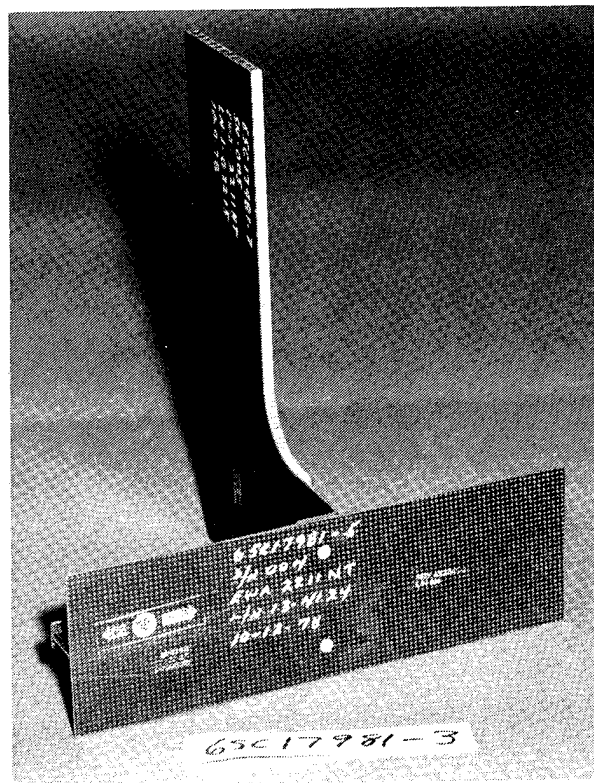

Figure 39. Panel-to-Rib Joint Test

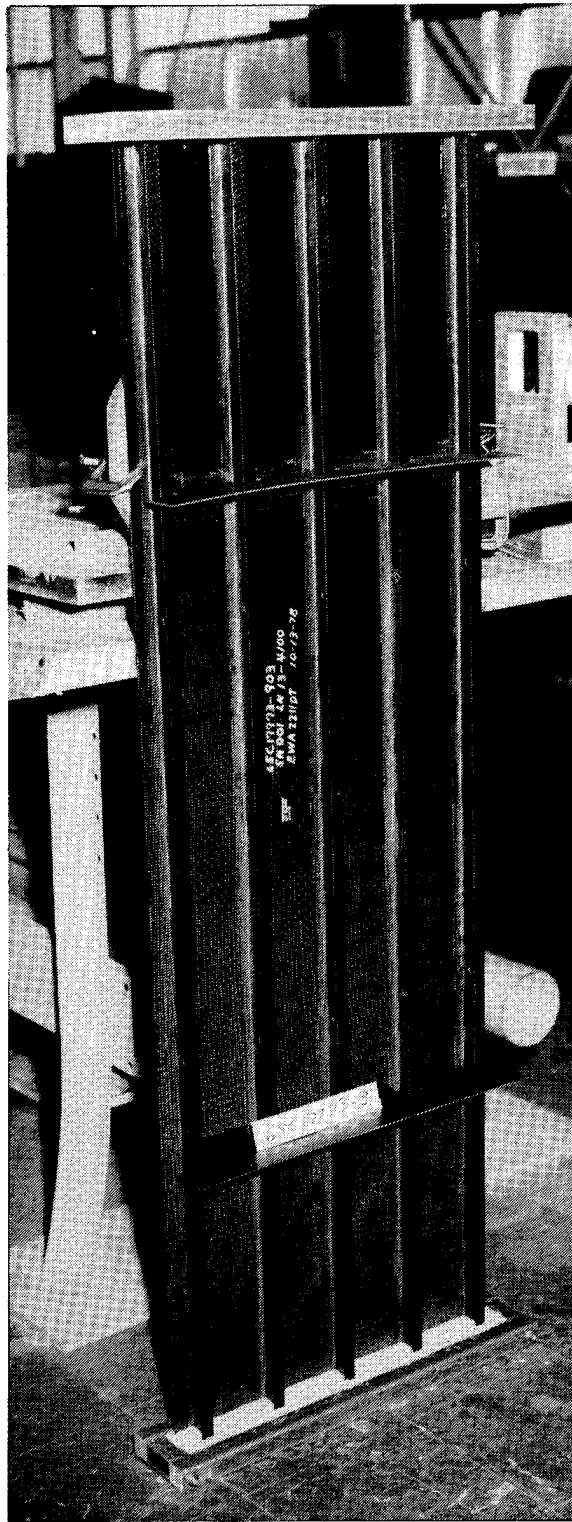

Figure 40. Compression Test Panel—Stiffened Side

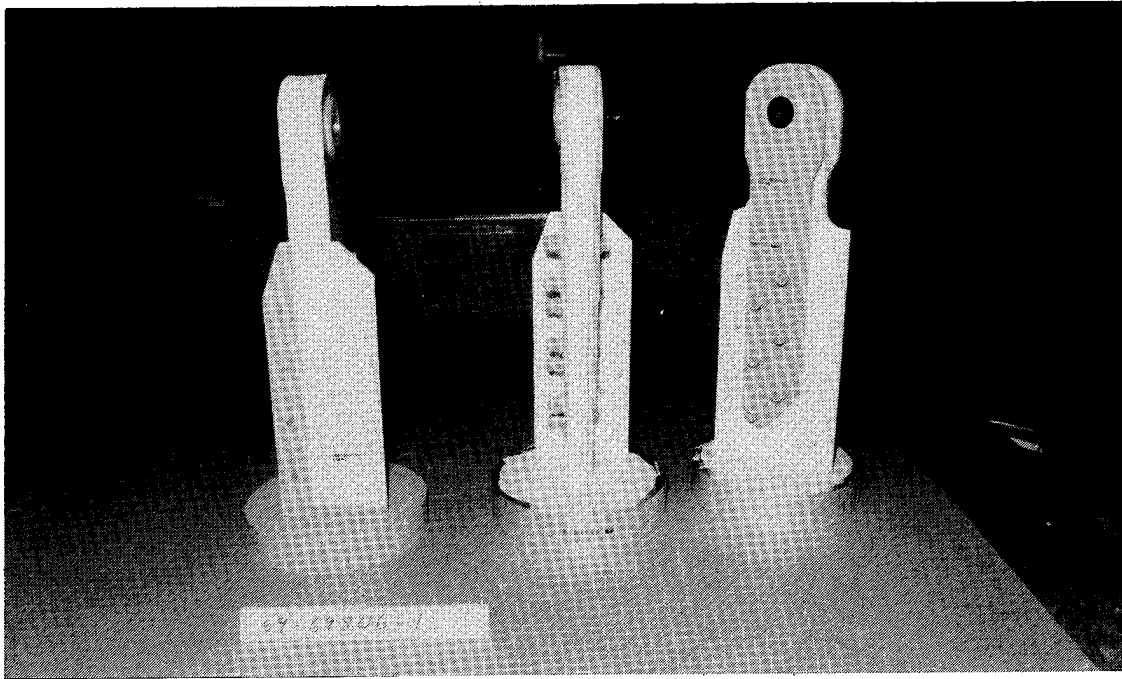

Figure 41. Spar Lug—Completed Compression Specimens

5.3 MANUFACTURING VERIFICATION HARDWARE

The Test 21 stub box of the ancillary test program was used for manufacturing verification. Figures 42 through 47 show components in fabrication and assembly.

Problems encountered during development included:

- Excessive resin bleedout and bag failures during cure of the first chord detail parts were eliminated in subsequent production by modifying processing procedures that have been incorporated into an updated process specification.
- Material buildup in corner areas of the first honeycomb ribs was deemed inherent in the design and certain to result in part rejection and/or rework. The engineering revision shown in Figure 48 improved the design and eliminated the problem.
- The first production verification I-stiffened skin panel provided two major problems: excessive panel warpage and unacceptable porosity on the tool side skin surface. The warpage was approximately halved, 1.40 cm (0.55 in) to 0.76 cm (0.30 in), by substituting woven fabric for unidirectional tape along the stringer top (fig. 30, sec. 5.1). Skin surface porosity was reduced to a level that allowed routine finishing to provide an aerodynamically sound surface by using tows of fiberglass yarn to provide paths for improved air evacuation on the toolside during bagging and cure. This procedure, using fiberglass yarn in proportion to layup area, has been incorporated into the process specification.

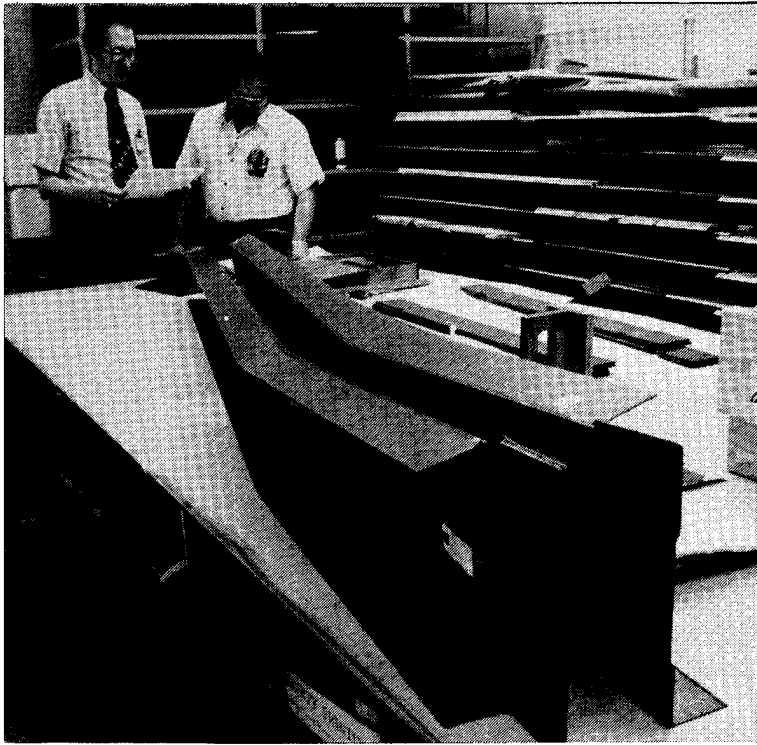

Figure 42. Stub Box Front Spar—Completed Details Being Inspected



Figure 43. Stub Box I-Stiffened Skin Panel—Layup of I-Stiffeners

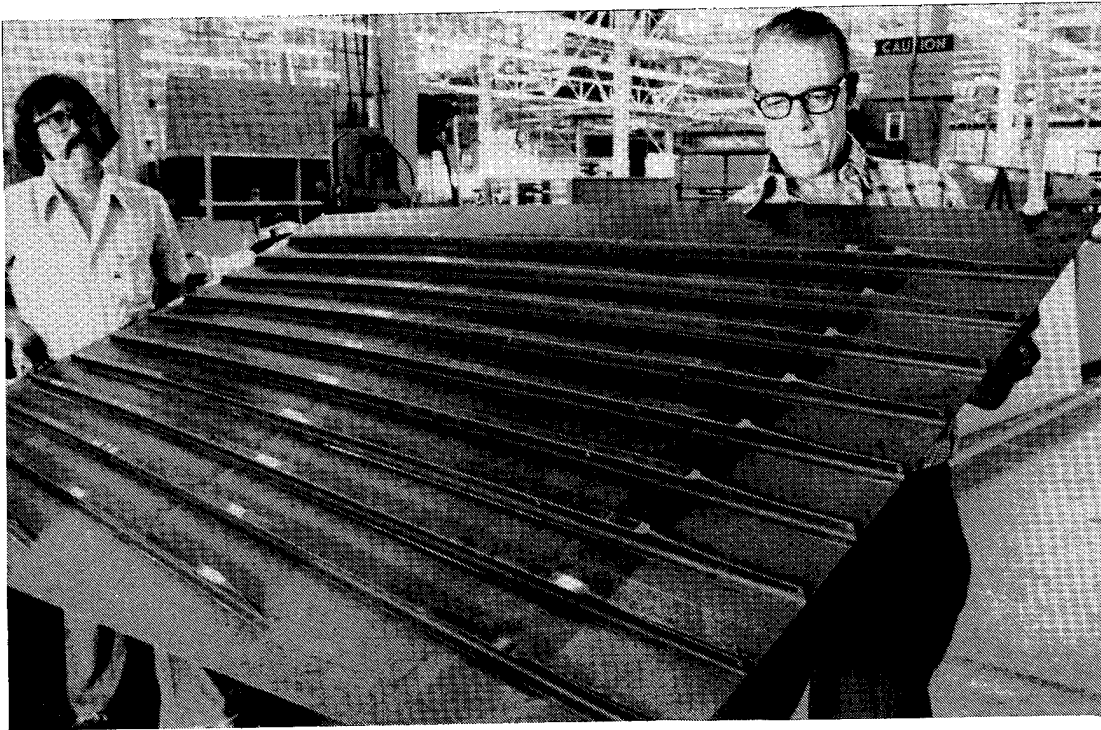

Figure 44. Stub Box I-Stiffened Skin Panel—Trimmed Part

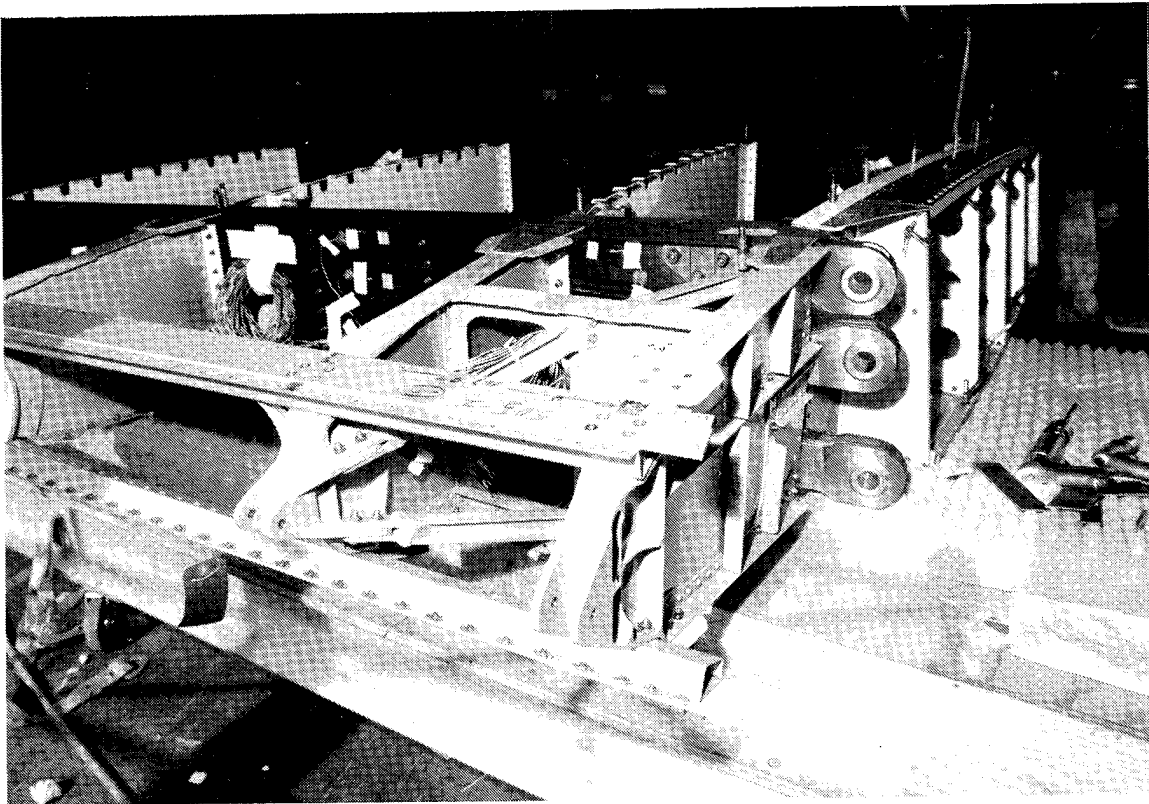

Figure 45. Stub Box—Trailing-Edge Beam, Rear Spar, and Graphite-Epoxy Ribs in Place

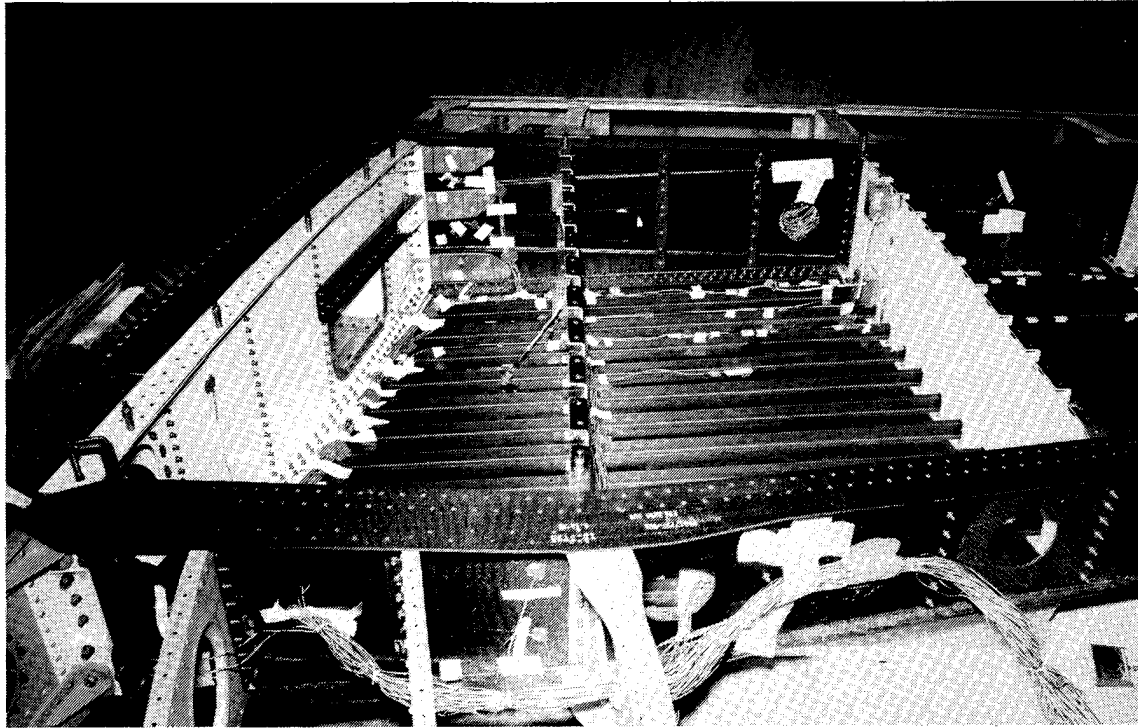

Figure 46. Stub Box—Front and Rear Spar, Lower Skin Panel, and Ribs With Instrumentation

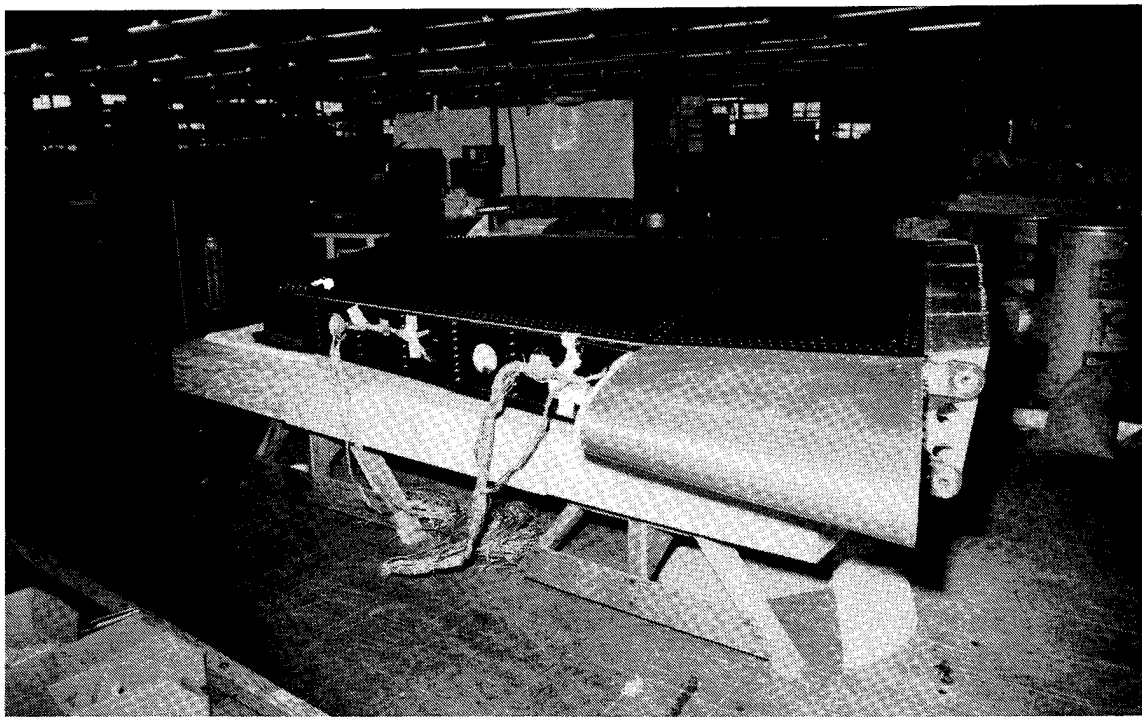

Figure 47. Stub Box—Front View of Completed Assembly

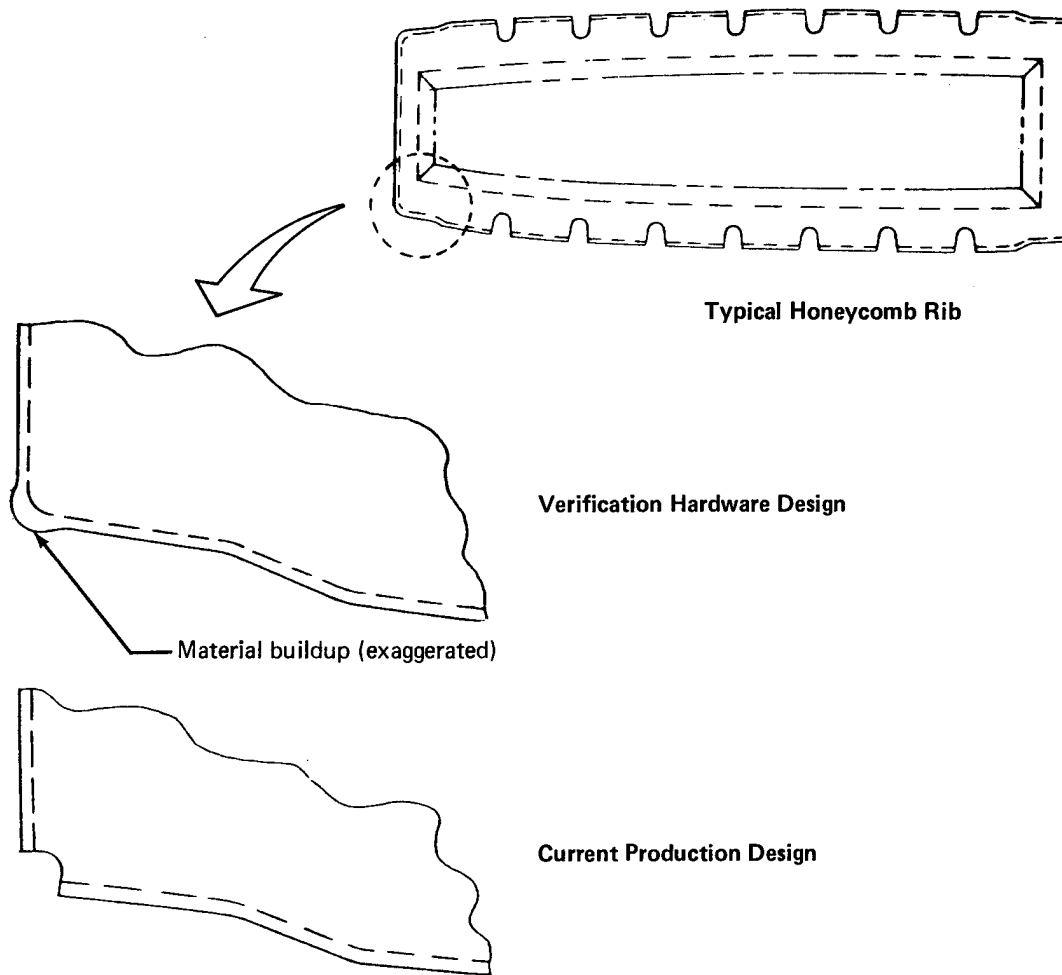

Figure 48. Honeycomb Rib—Evolution of Design

5.4 QUALITY ASSURANCE DEVELOPMENT

This section reviews the development of nondestructive test standards for standard laminate defect specimens and inspection procedures. It also includes a summary of the discrepancy analysis of the composite parts produced.

5.4.1 Nondestructive Inspection Development

Standards were fabricated to evaluate test techniques and establish procedures for the nondestructive inspection of the composite parts. Two types of standards were built and used in the evaluation: preliminary standards, which represented anticipated detail designs, and production standards, which exactly reproduced the part configuration. The first was used to evaluate the test techniques, and the second was used to provide structural sections, duplicating production parts, to select and refine test procedures. Figures 49 and 50 show representative standards used to evaluate test techniques and equipment. Figures 51 through 55 show production part replicate standards and test equipment.

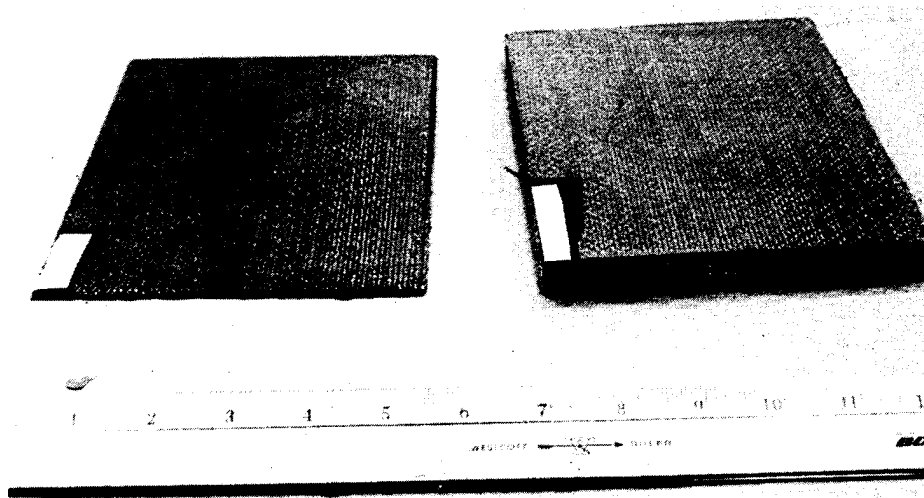

Figure 49. Nondestructive Inspection Standards for Test Technique Evaluation

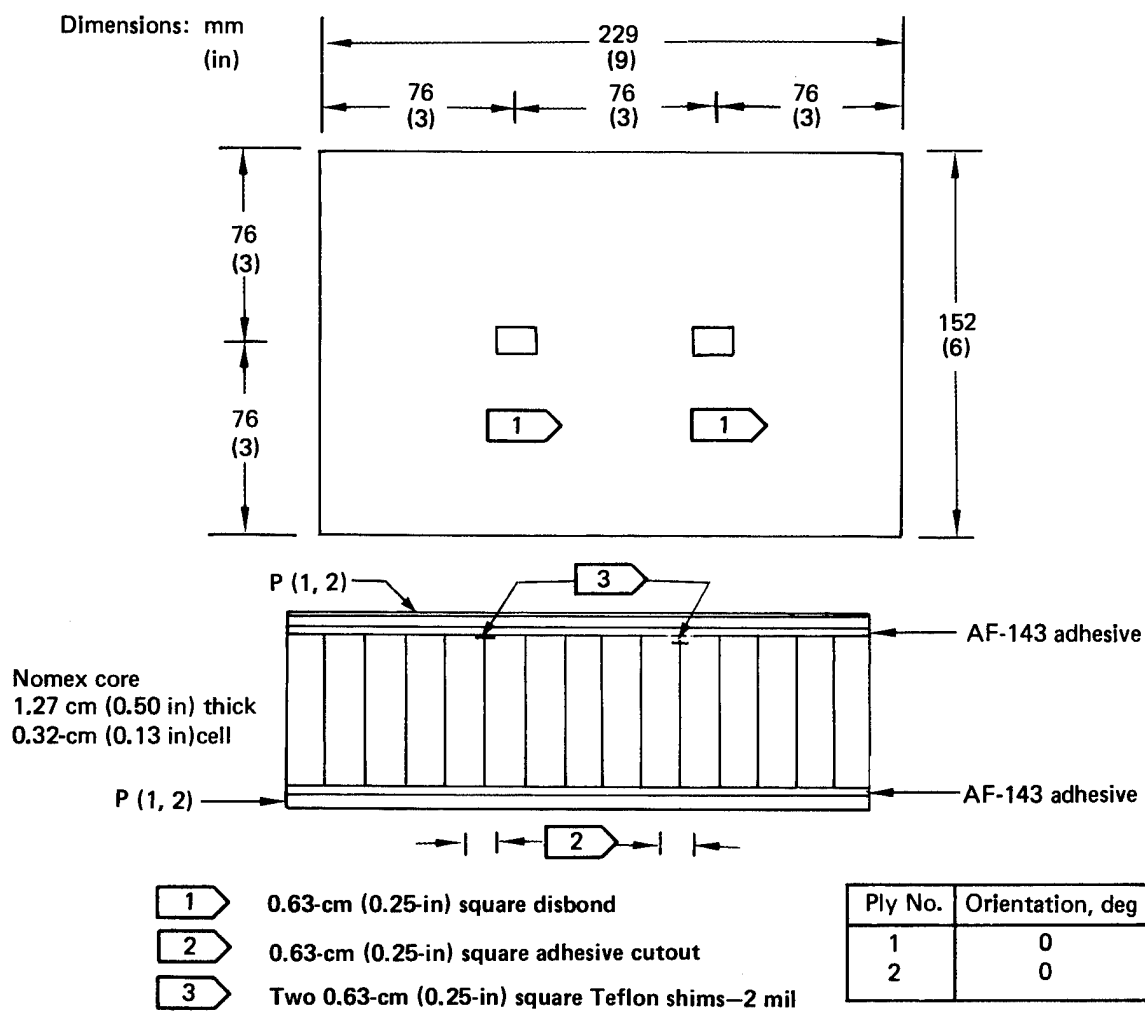

Figure 50. Nondestructive Inspection Standard Layup With Defect Inclusions

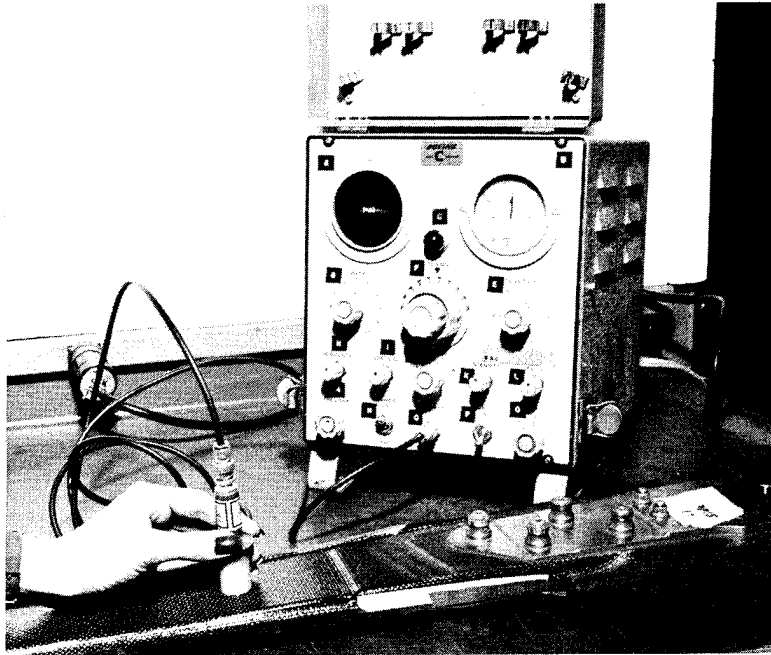

Figure 51. Fokker Bond Testing of Rear-Spar Assembly

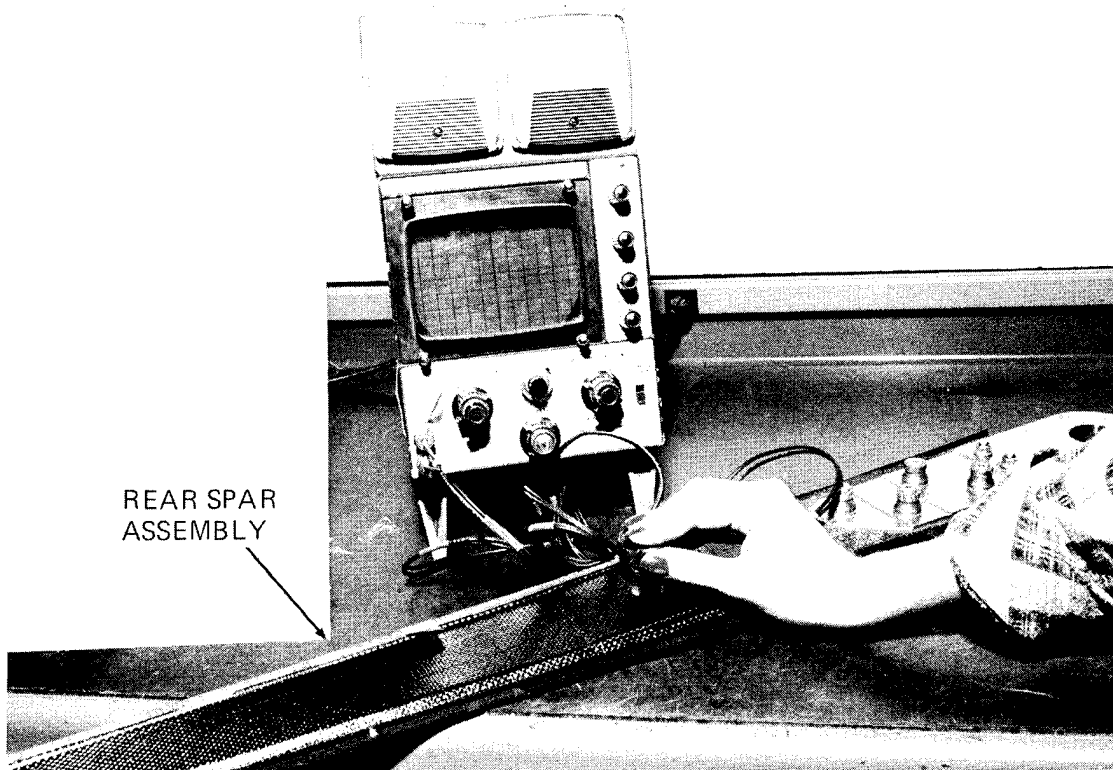
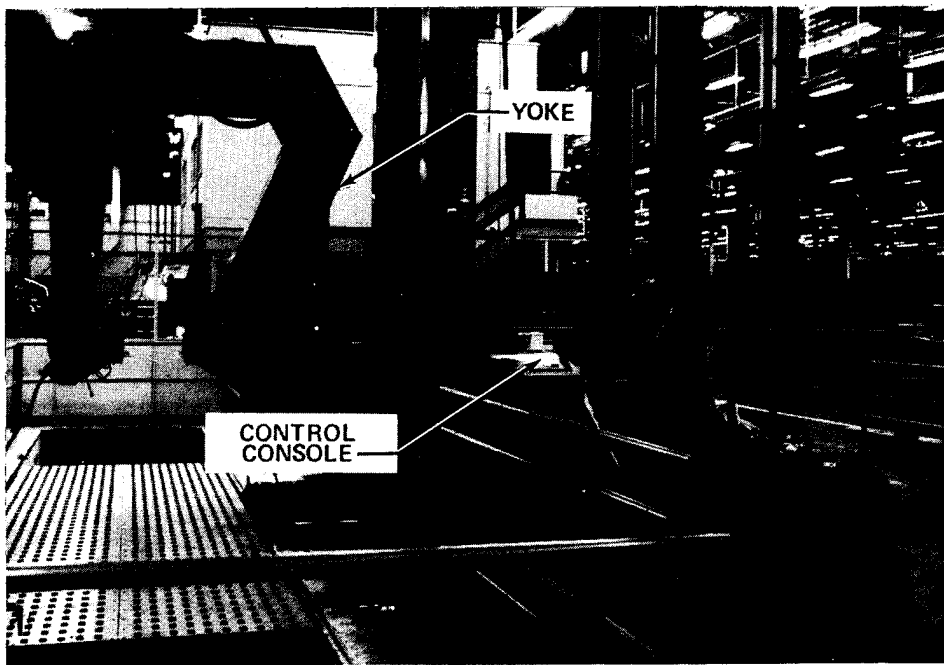

Figure 52. Sonicator Inspection of Rear-Spar Assembly



*Figure 53. Automated Through-Transmission Ultrasonic Inspection—
Large Structures*

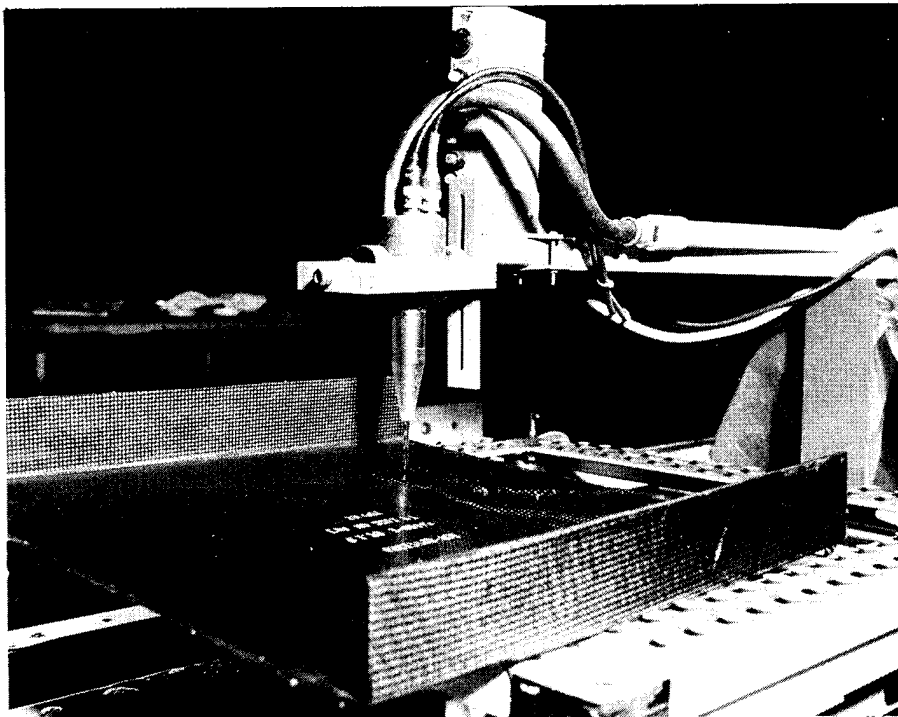

Figure 54. Through-Transmission Ultrasonic Inspection—Details

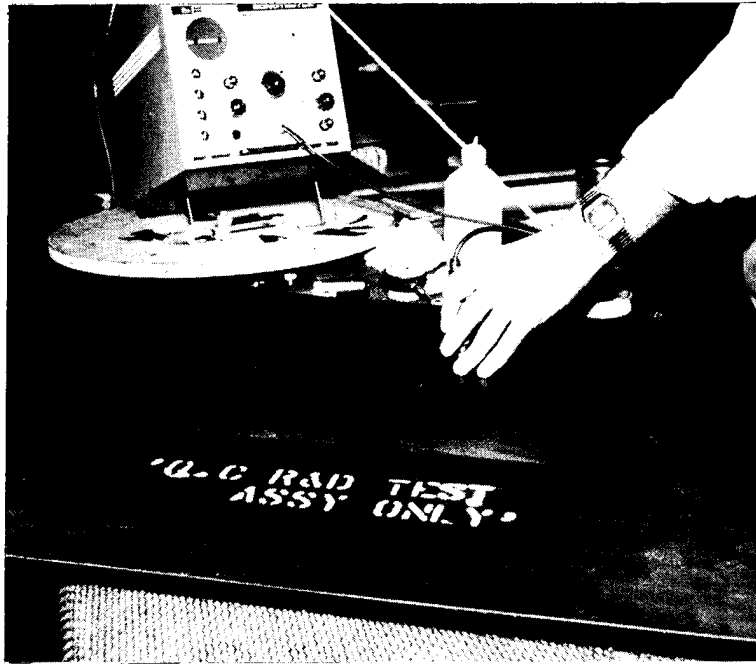

Figure 55. Fokker Bond Testing of Skin-to-Cap Bond of I-Stiffener Panel

Nondestructive inspection techniques evaluated were:

- Through-Transmission Ultrasonic, automated, with computerized printout
- Through-Transmission Ultrasonic with manual scanning
- Sondicator, low-frequency resonating sound for use on honeycomb structures (ref. 13)
- Fokker Bond Tester, high-frequency pulse/echo sound for use on laminate structures (ref. 13)
- Low voltage, X-ray

All defects were detectable by one or more of the above techniques.

5.4.2 Discrepancy Analysis

The collected rejection tags from all manufacturing plans were used to catalog discrepancies for type, frequency, assignable cause, and disposition. These data are summarized in Figure 56.

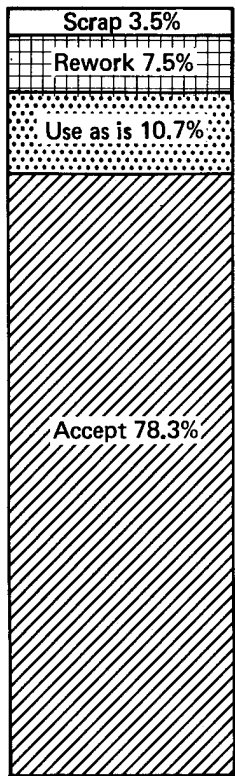

1722 parts

1

- Operator/machine error—dimensional, not to drawing
- Process failure—bag broke, test panel fail
- Surface discrepancies—resin starvation, scratches
- Miscellaneous—voids, delamination

Percentage of total discrepancies

32
14
50
4
100

1 374 discrepant parts (21.7%)

Figure 56. 737 Stabilizer Accept/Reject Evaluation

6.0 CONCLUSIONS

NASA established a program for primary composite structures under the Aircraft Energy Efficiency (ACEE) program. As part of this program, Boeing has redesigned and fabricated the horizontal stabilizer of the 737 transport using composite materials. Five shipsets were fabricated, and FAA certification has been obtained. Airline introduction will follow.

Key program results are:

- Weight reduction greater than the 20% goal has been achieved.
- Parts and assemblies were readily produced on production-type tooling.
- Quality assurance methods were demonstrated.
- Repair methods were developed and demonstrated.
- Strength and stiffness analytical methods were substantiated by comparison with test results.
- Cost data was accumulated in a semiproduction environment.
- FAA certification has been obtained.

The program has provided the necessary confidence for the company to commit use of composite structure in similar applications on new generation aircraft and has laid the groundwork for design of larger, more heavily loaded composite primary structure.

7.0 REFERENCES

1. Aniversario, R. B.; Harvey, S. T.; McCarty, J. E.; Parsons, J. T.; Peterson, D. C.; Pritchett, L. D.; Wilson, D. R.; and Wogulis, E. R.: Design, Ancillary Testing, Analysis, and Fabrication Data for the Advanced Composite Stabilizer for Boeing 737 Aircraft. Volume II—Final Report. NASA CR-166011, December 1982.
2. Jackson, A. C. et al.: Advanced Manufacturing Development of a Composite Empennage Component for L-1011 Aircraft. Phase II Final Report Design and Analysis. NASA CR-165634, April 1981.
3. Hoffman, D. J.: 737 Graphite Composite Flight Spoiler Flight Service Evaluation Sixth Annual Report. NASA CR-159362, November 1980.
4. Gibbins, M. N. and Hoffman, D. J.: Environmental Exposure Effects on Composite Materials for Commercial Aircraft. NASA CR-3502, January 1982.
5. Ahlers, R. H.: Stability of Structure Following Bird Strikes, FAA-ADS-60, March 1966.
6. McNaughtan, I. I.: The Design of Leading Edge and Intake Wall Structure to Resist Bird Impact. Royal Aircraft Establishment Technical Report 72056, 1972.
7. Federal Aviation Regulations, Part 25, Airworthiness Standards: Transport Category Airplanes. Department of Transportation, Federal Aviation Administration, December 1978.
8. Composite Aircraft Structure, Advisory Circular 20-107. Federal Aviation Administration, July 1978.
9. Aniversario, R. B.; Harvey, S. T.; McCarty, J. E.; Parsons, J. T.; Peterson, D. C.; Pritchett, L. D.; Wilson, D. R.; and Wogulis, E. R.: Full-Scale Testing, Production, and Cost Analysis Data for the Advanced Composite Stabilizer for Boeing 737 Aircraft. Volume I—Technical Summary. NASA CR-3649, 1983.
10. Aniversario, R. B.; Harvey, S. T.; McCarty, J. E.; Parsons, J. T.; Peterson, D. C.; Pritchett, L. D.; Wilson, D. R.; and Wogulis, E. R.: Full-Scale Testing, Production, and Cost Analysis Data for the Advanced Composite Stabilizer for Boeing 737 Aircraft. Volume II—Final Report. NASA CR-166012, December 1982.
11. Johnson, R. W.; McCarty, J. E.; and Wilson, D. R.: Damage Tolerance Testing for the Boeing 737 Graphite-Epoxy Horizontal Stabilizer. Proceedings of the Fifth DOD/NASA Conference on Fibrous Composites in Structure Design. NADC-81096-60, Vols. I and II, New Orleans, Louisiana, January 1981.
12. Chovil, D. V.; Harvey, S. T.; McCarty, J. E.; Desper, O. E.; Jamison, E. S.; and Syder, H.: Advanced Composite Elevator for Boeing 727 Aircraft. Volume I—Technical Summary. NASA CR-3290, 1981.
13. Horton, R. E. and McCarty, J. E.: Adhesive Bonded Aerospace Structures Standardized Repair Handbook. AFML-TR-77-206/AFFDL-TR-77-139, October 1977.

1. Report No. NASA CR-3648	2. Government Accession No.	3. Recipient's Catalog No.	
4. Title and Subtitle DESIGN, ANCILLARY TESTING, ANALYSIS, AND FABRICATION DATA FOR THE ADVANCED COMPOSITE STABILIZER FOR BOEING 737 AIRCRAFT, VOLUME I - TECHNICAL SUMMARY		5. Report Date April 1983	
		6. Performing Organization Code	
7. Author(s) R.B. Aniversario, S.T. Harvey, J.E. McCarty, J.T. Parsons, D.C. Peterson, L.D. Pritchett, D.R. Wilson, and E.R. Wogulis		8. Performing Organization Report No. D6-46037-1	
		10. Work Unit No.	
9. Performing Organization Name and Address Boeing Commercial Airplane Company P.O. Box 3707 Seattle, Washington 98124		11. Contract or Grant No. NAS1-15025	
		13. Type of Report and Period Covered Contractor Report	
12. Sponsoring Agency Name and Address National Aeronautics and Space Administration Washington, D.C. 20546		14. Sponsoring Agency Code	
15. Supplementary Notes Langley Technical Monitor: A.J. Chapman Final Report			
16. Abstract This report defines and discusses the design, development, analyses, and production activities that were required to produce five-and-one-half advanced-composite stabilizer shipsets for Boeing 737 aircraft.			
17. Key Words (Suggested by Author(s)) advanced composites long-term durability structural integrity weight savings		18. Distribution Statement FEED distribution Subject Category 24	
19. Security Classif. (of this report) Unclassified	20. Security Classif. (of this page) Unclassified	21. No. of Pages 66	22. Price