

ARMY RESEARCH LABORATORY



U.S. Army Materiel Command (AMC)
Field Assistance in Science and
Technology-Jr. (FAST-JR) Project:
Arctic Troop Cover (ATC)

John A. Condon
Peter J. Fazio

ARL-MR-274

November 1995

*Original contains color
plates: All DTIC reproductions
will be in black and
white*

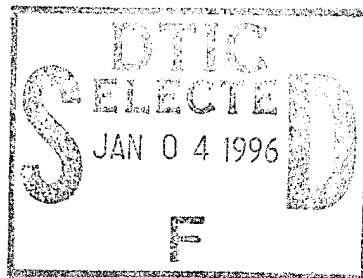

19960102 003

BEST QUALITY REPRODUCTION

NOTICES

Destroy this report when it is no longer needed. DO NOT return it to the originator.

Additional copies of this report may be obtained from the National Technical Information Service, U.S. Department of Commerce, 5285 Port Royal Road, Springfield, VA 22161.

The findings of this report are not to be construed as an official Department of the Army position, unless so designated by other authorized documents.

The use of trade names or manufacturers' names in this report does not constitute indorsement of any commercial product.

DISCLAIMER NOTICE

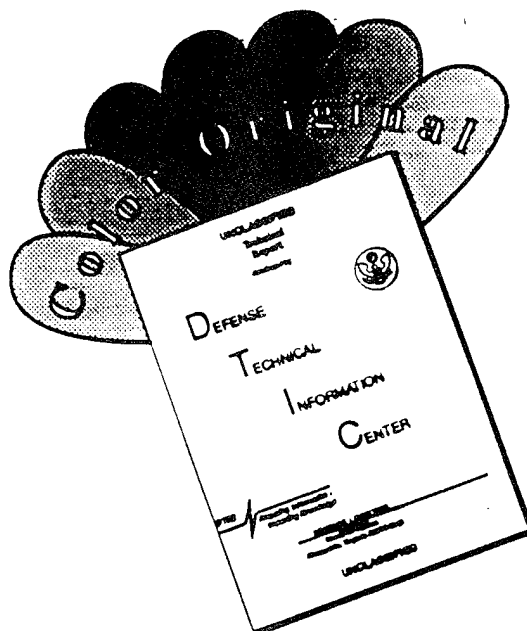

THIS DOCUMENT IS BEST QUALITY AVAILABLE. THE COPY FURNISHED TO DTIC CONTAINED A SIGNIFICANT NUMBER OF COLOR PAGES WHICH DO NOT REPRODUCE LEGIBLY ON BLACK AND WHITE MICROFICHE.

REPORT DOCUMENTATION PAGE			Form Approved OMB No. 0704-0188	
Public reporting burden for this collection of information is estimated to average 1 hour per response, including the time for reviewing instructions, searching existing data sources, gathering and maintaining the data needed, and completing and reviewing the collection of information. Send comments regarding this burden estimate or any other aspect of this collection of information, including suggestions for reducing this burden, to Washington Headquarters Services, Directorate for Information Operations and Reports, 1215 Jefferson Davis Highway, Suite 1204, Arlington, VA 22202-4302, and to the Office of Management and Budget, Paperwork Reduction Project(0704-0188), Washington, DC 20503.				
1. AGENCY USE ONLY (Leave blank)	2. REPORT DATE November 1995	3. REPORT TYPE AND DATES COVERED Final, May 1994-May 1995		
4. TITLE AND SUBTITLE U.S. Army Materiel Command (AMC) Field Assistance in Science and Technology-Jr. (FAST-JR) Project: Arctic Troop Cover (ATC)			5. FUNDING NUMBERS PR: 1L162618AH80	
6. AUTHOR(S) John A. Condon and Peter J. Fazio				
7. PERFORMING ORGANIZATION NAME(S) AND ADDRESS(ES) U.S. Army Research Laboratory ATTN: AMSRL-WT-WE Aberdeen Proving Ground, MD 21005-5066			8. PERFORMING ORGANIZATION REPORT NUMBER ARL-MR-274	
9. SPONSORING/MONITORING AGENCY NAMES(S) AND ADDRESS(ES)			10. SPONSORING/MONITORING AGENCY REPORT NUMBER	
11. SUPPLEMENTARY NOTES				
12a. DISTRIBUTION/AVAILABILITY STATEMENT Approved for public release; distribution is unlimited.			12b. DISTRIBUTION CODE	
13. ABSTRACT (Maximum 200 words) The present troop cover for the 2.5-ton (M35A2) truck is an outdated design that is heavy and difficult to handle in the extreme cold weather of the arctic environment. The 2.5-ton truck is being replaced by the 5-ton (M923/M939A2) truck, which at present has no provision for an arctic troop enclosure. There now exists a need for an arctic specification troop enclosure for the 5-ton truck that does not compromise the 5-ton truck's cargo-carrying capability. A prototype arctic troop cover (ATC) has been fabricated at the Directorate of Logistics (DOL) Maintenance Facility located at Fort Richardson, AK. The prototype ATC is attached to the 5-ton truck through a six-point attachment scheme. The authors were tasked by the U.S. Army Materiel Command (AMC) Field Assistance in Science and Technology (FAST) via the Alaskan Command (ALCOM) Science Advisor to determine whether or not the scheme for attaching the ATC to the 5-ton truck bed was sound from a structural viewpoint under a worst-case rail impact loading situation. The attachment scheme proved to be structurally deficient for the loading case considered. The analysis findings and recommendations for correcting the deficiencies are documented in this report.				
14. SUBJECT TERMS simulated test plan, arctic troop cover (ATC), 5-ton truck, finite element analysis			15. NUMBER OF PAGES 30	
			16. PRICE CODE	
17. SECURITY CLASSIFICATION OF REPORT UNCLASSIFIED	18. SECURITY CLASSIFICATION OF THIS PAGE UNCLASSIFIED	19. SECURITY CLASSIFICATION OF ABSTRACT UNCLASSIFIED	20. LIMITATION OF ABSTRACT UL	

INTENTIONALLY LEFT BLANK.

TABLE OF CONTENTS

		<u>Page</u>
	LIST OF FIGURES	v
	LIST OF TABLES	vii
1.	INTRODUCTION	1
2.	ANALYSES	4
2.1	Initial Calculations	4
2.2	FEA Structural Analysis and Results	14
3.	PROPOSED TESTING	15
4.	RECOMMENDATIONS AND CONCLUSIONS	22
	LIST OF ABBREVIATIONS	23
	DISTRIBUTION LIST	25

Accession For	
NTIS CRA&I	<input checked="" type="checkbox"/>
DTIC TAB	<input type="checkbox"/>
Unannounced	<input type="checkbox"/>
Justification	
By	
Distribution /	
Availability Codes	
Dist	Avail and/or Special
A-1	

INTENTIONALLY LEFT BLANK.

LIST OF FIGURES

<u>Figure</u>		<u>Page</u>
1.	Arctic troop cover	1
2.	Five-ton truck with ATC mounted	3
3.	Rear of ATC	5
4.	Closeup, rear of ATC to cargo body, part 1	5
5.	Rear of 5-ton truck with ATC mounted	6
6.	Closeup, rear dropside to ATC, part 2	7
7.	Front of ATC by itself	7
8.	Closeup, front dropside to ATC, part 3	8
9.	Front dropside to ATC locking handle for part 3	9
10.	Sketch of part 1	11
11.	Sketch of part 2	12
12.	Sketch of part 3	13
13.	FEA structural model	14
14.	Part 1 model and predicted stresses	16
15.	Part 2 model and predicted stresses	17
16.	Part 3 model and predicted stresses	18
17.	Cab mount acceleration vs. time record	19
18.	Test setup	20

INTENTIONALLY LEFT BLANK.

LIST OF TABLES

<u>Table</u>	<u>Page</u>
1. Attachment Initial Calculation Results	6
2. FEA Predictions at 30-g Longitudinal Acceleration Load Case	15
3. Improvements	22

INTENTIONALLY LEFT BLANK.

1. INTRODUCTION

The present troop cover for the 2.5-ton (M35A2) truck is an outdated design that is heavy and difficult to handle in the extreme cold weather of the arctic environment. The 2.5-ton truck is being replaced by the 5-ton (M923/M939A2) truck, which at present has no provision for an arctic troop enclosure. There now exists a need for an arctic specification troop enclosure for the 5-ton truck that does not compromise the truck's cargo-carrying capability.

A prototype arctic troop cover (ATC) has been fabricated at the Directorate of Logistics (DOL) Maintenance Facility located at Fort Richardson, AK. It is composed of all stock, "off-the-shelf" items based upon a salvaged 2.5-ton truck bed. The salvaged truck bed is fitted with an insulated personnel carrier (PC) kit (see Figure 1) and an arctic specification troop heater. The salvaged 2.5-ton truck bed with PC kit is then modified such that it can be forklifted and attached to the cargo bed of the 5-ton truck.

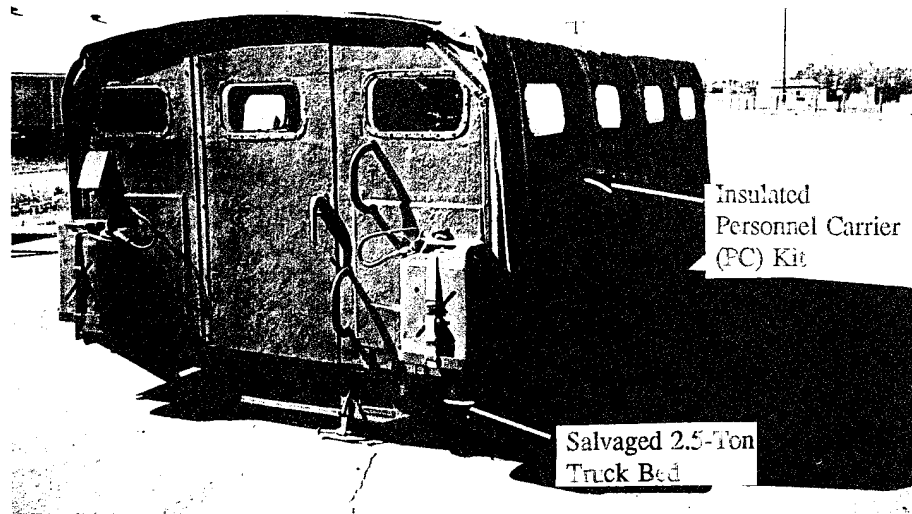

Figure 1. Arctic troop cover.

The ATC is attached to the 5-ton truck through a six-point attachment scheme (see Figure 2). The modular construction and simple attachment allows the 5-ton truck to act as both a troop carrier in an arctic environment and as a cargo carrier. Mounting and removal times for the ATC are approximately 20 and 15 min, respectively, for a two-man team. The rear of the ATC is attached to the 5-ton truck bed via four attachment points. These four attachment points consist of two steel-hinge brackets (part 1) and two steel pins. The other two attach the ATC to the rear of the dropside via two steel plate attachments (part 2) and two grade 6 bolts. The front of the ATC is attached to the front of the dropside via two steel plate attachments (part 3) and dropside locking handles. The attachment scheme is symmetrical with the longitudinal centerline of the vehicle.

Until this study, the prototype ATC had not received any formal testing or analysis relating to the structural strength and integrity of the attachment hardware. This lack of testing and/or analysis precluded the prototype from receiving a safety release, which is needed before other forms of testing take place. The Alaskan Command (ALCOM) Science Advisor requested the U.S. Army Materiel Command (AMC) Field Assistance in Science and Technology (FAST) quick reaction coordinators to provide a Field Assistance in Science and Technology-Jr. (FAST-JR) scientist/engineer to perform an analysis on the prototype ATC concept (AMC FAST Quarterly Report, July-September 1994). The authors accepted the task of determining whether or not the scheme for attaching the ATC to the 5-ton truck bed was sound from a structural viewpoint under a worst-case loading situation and, if not, to make recommendations as to where the attachments would need to be upgraded or improved.

First, a visit was made to Fort Richardson to gather and verify information that had been previously provided through phone conversations and electronic mail. Photos were taken of various views of the ATC and its attachments to aid in the modeling effort. Hand sketches of the individual attachments, including physical dimensions and characteristics, were sent to the U.S. Army Research Laboratory (ARL) after the trip. These sketches were necessary to the structural analysis efforts.

The first step in the analysis focused upon what is defined as a worst-case loading situation. Through discussions with engineers at the U.S. Army Combat Systems Test Activity (CSTA) Natick Research, Development, and Engineering Center, and the Military Traffic Management Command (MTMC), it became clear that the worst-case loading occurred during rail impacting. Rail impacting occurs when train rail cars couple. Typically, a moving rail car will couple to a stationary rail car at speeds from 4 to 8 mph. When a railcar (with a vehicle secured to the loadbed) undergoes rail impact due to coupling, the

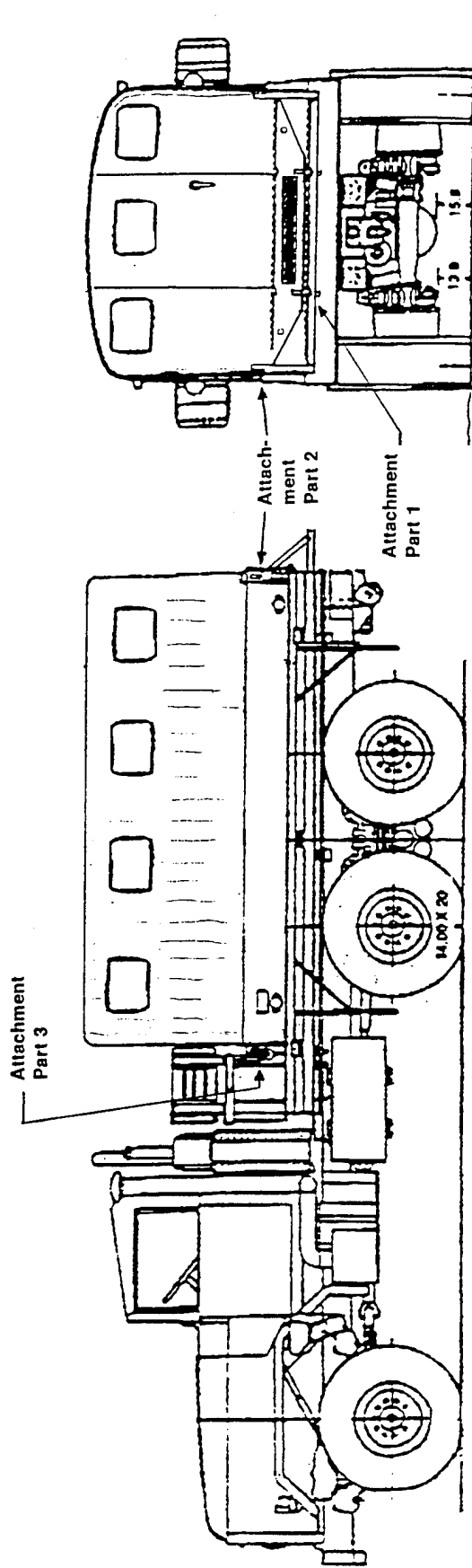

Figure 2. Five-ton truck with ATC mounted.

secured vehicle experiences high accelerations on the order of 30 g longitudinally, 20 g vertically, and 8 g transversely. These accelerations produce large forces on the vehicle and on any structures attached to the vehicle. Hence, our concern focused specifically upon the structural strength of the hardware that attaches the ATC to the loadbed of the 5-ton truck. Through the MTMC, we were able to obtain acceleration data taken on a 5-ton truck (M923) that had undergone rail impact testing at CSTA. These data, which contain peak values and time histories, were used as the basis for our analyses. From these data, we selected longitudinal accelerations, which we presumed to be representative of the highest accelerations (instead of transverse and vertical components of acceleration) experienced by the attaching hardware for the ATC.

The analysis plan consisted of three parts: 1) initial calculations of stress based upon estimates of worst-case acceleration, the mass of the ATC, and the physical parameters of the attachment hardware; 2) finite element analysis (FEA) to provide a better understanding of the stress states in each of the attachments under a dynamic applied loading; and 3) a simulated test plan was made to provide a means of verifying the analysis results and to provide a test bed for improved attachment concepts. The testing would incorporate dynamic strain- and dynamic force-type instrumentation applied to the attachment test specimen to acquire data to directly correlate with the FEA predictions. It was believed that sources of failure in the test attachments could be compared with the FEA model predictions. A "low-cost" optimization of the attachments could then be made based on predictions from subsequent modified attachment FEA iterations. Ideally, agreement between all three efforts (including initial calculations, FEA results, and verification testing) would establish confidence in making recommendations on improving the attachment scheme. However, the recommendations made to the ALCOM Science Advisor by formal letter and presented in this report, were based exclusively on the initial calculations and FEA results. (Note: No verification testing was actually performed due to the project's cancellation.)

2. ANALYSES

2.1 Initial Calculations. Initial calculations of stress on portions of each of the three different types of attachments from an applied worst-case 30-g longitudinal rail impact loading were done. The three attachment types are shown in Figures 3–9. The weight of the ATC used was 2,800 lb (including heaters), not including troops and gear because it was assumed that the 5-ton truck (with ATC attached) would normally be in a transport mode while tied down to a railroad car; thus, no personnel or gear would be in the ATC at the time of rail impact. Table 1 lists the three attachment types, the lowest margin of safety

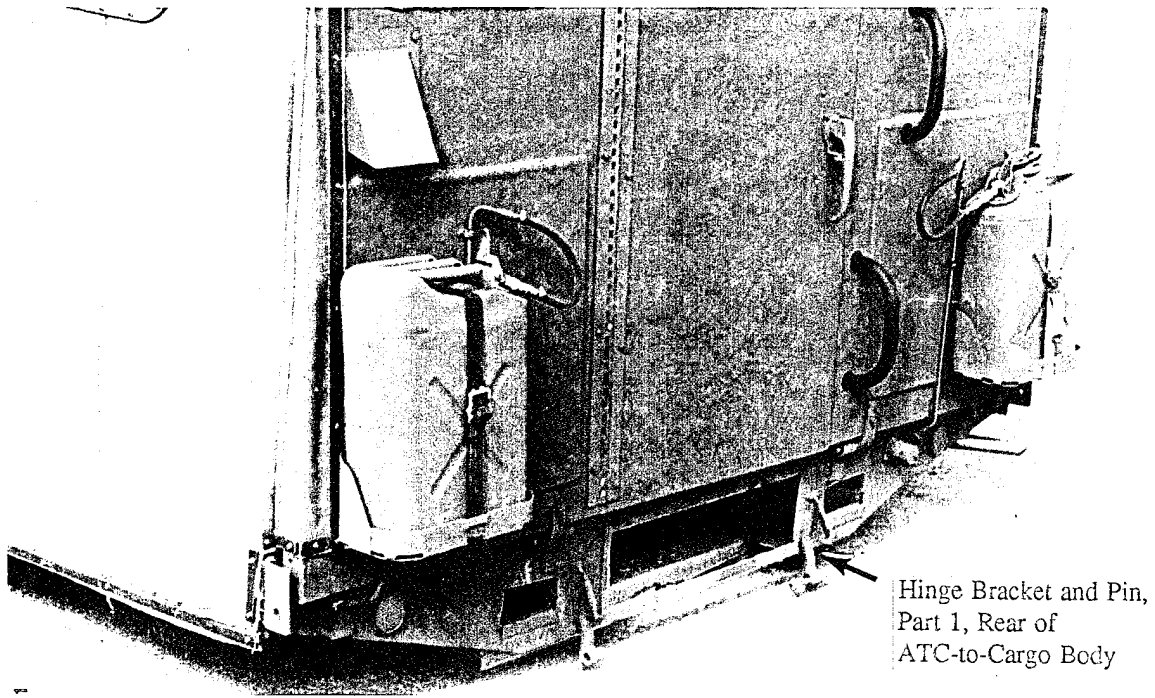

Hinge Bracket and Pin,
Part 1, Rear of
ATC-to-Cargo Body

Figure 3. Rear of ATC.



Figure 4. Closeup, rear of ATC to cargo body, part 1.

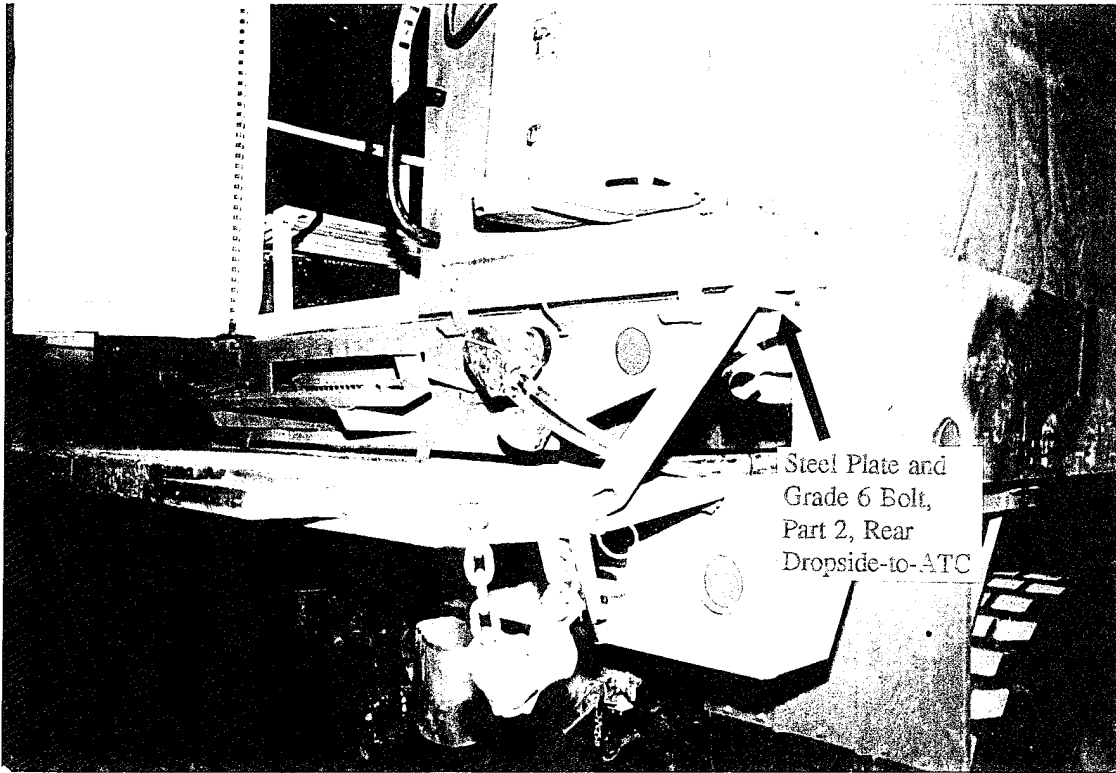

Figure 5. Rear of 5-ton truck with ATC mounted.

Table 1. Attachment Initial Calculation Results

Attachment Type	Lowest MS	Failure Mode	Comments
Rear of ATC to cargo body (part 1)	-0.94	Bending stress of upper steel hinge bracket.	This attachment will not support the applied bending load, FS = 0.06.
Rear dropside to ATC (part 2)	+0.17	Bearing stress on steel plate/angle at hole.	This attachment has an FS slightly. >1.0
Front dropside to ATC (part 3)	-0.42	Bearing stress on steel plate/angle at slot.	This attachment has an FS = 0.6 and the slot will fail at locking handle contact location.

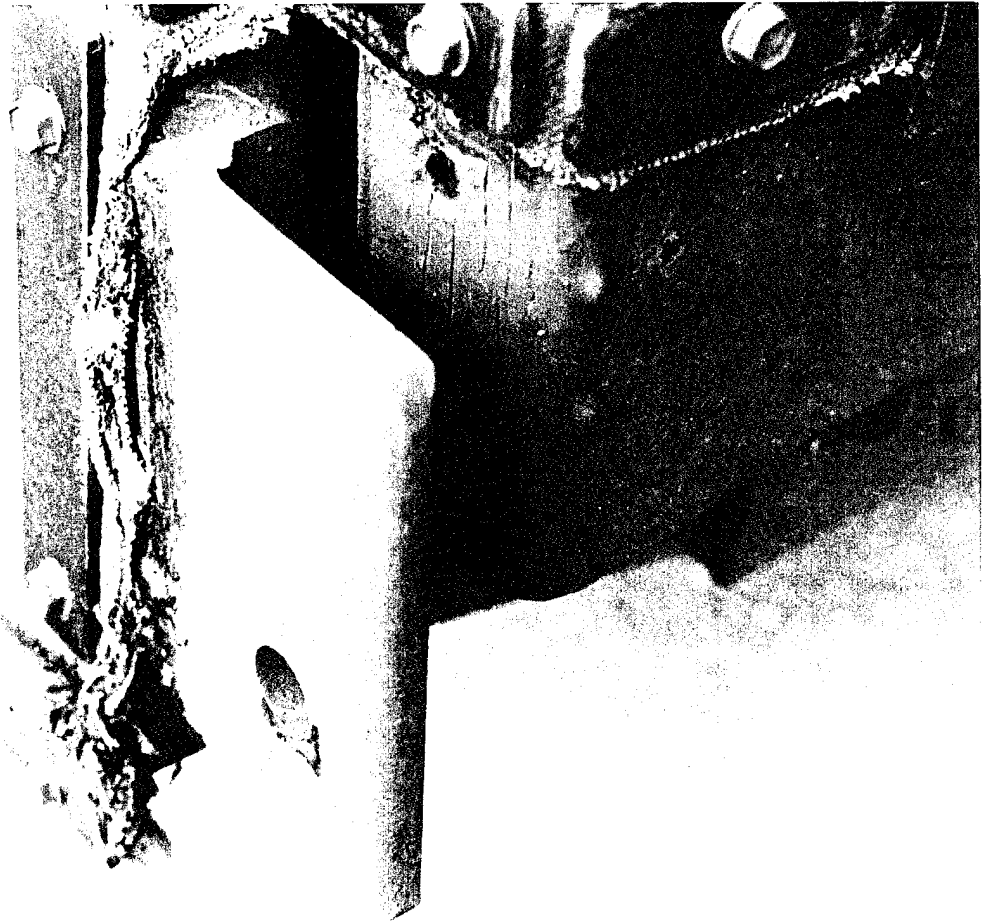
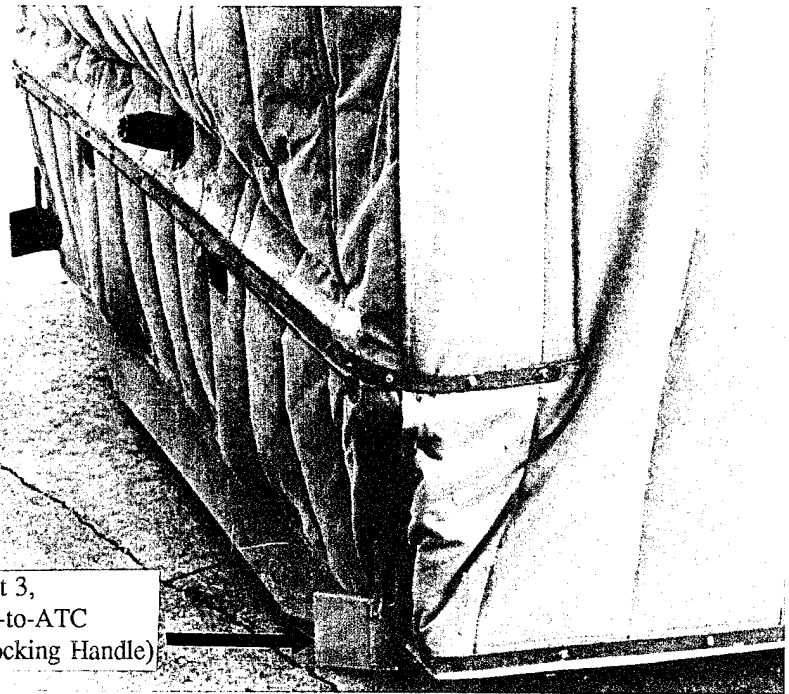

Figure 6. Closeup, rear dropside to ATC, part 2.



Steel Plate, Part 3,
Front Dropside-to-ATC
(Shown w/o Locking Handle)

Figure 7. Front of ATC by itself.

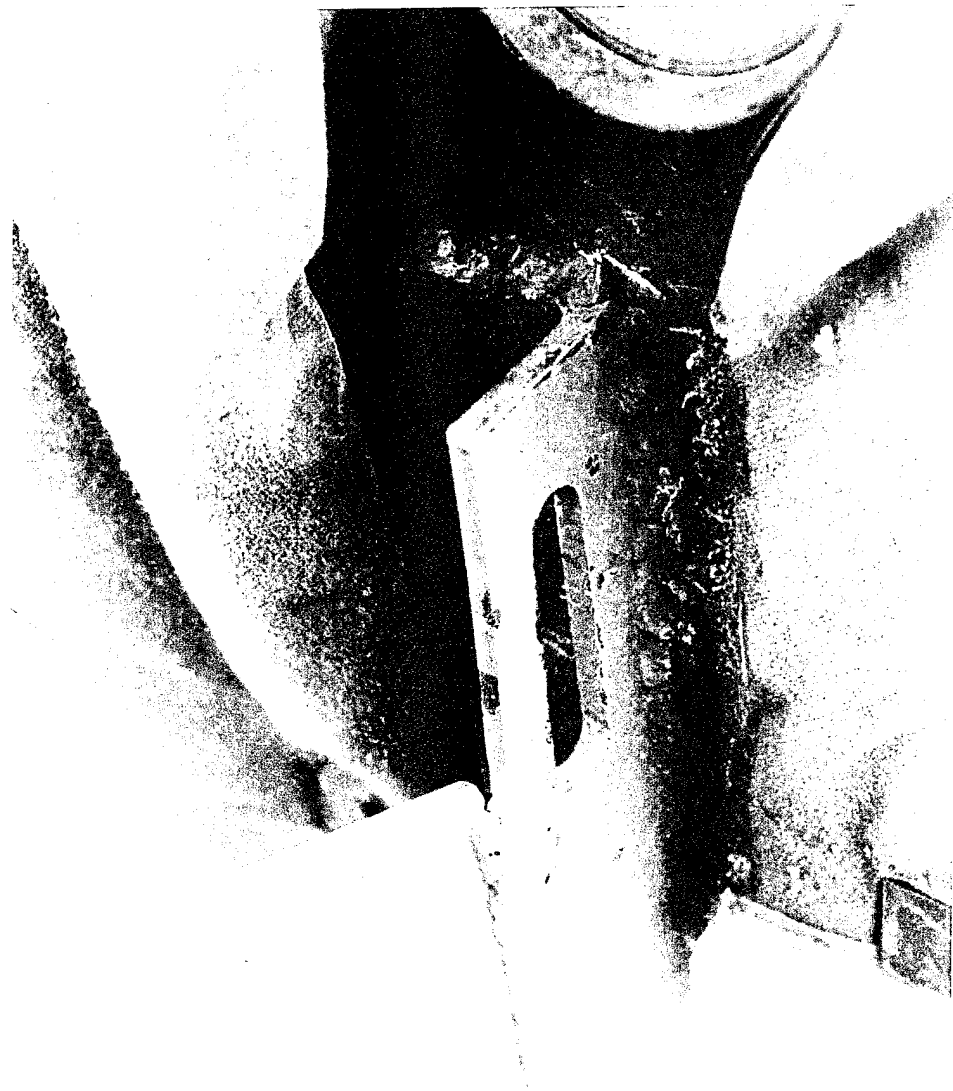

Figure 8. Closeup, front dropside to ATC, part 3.

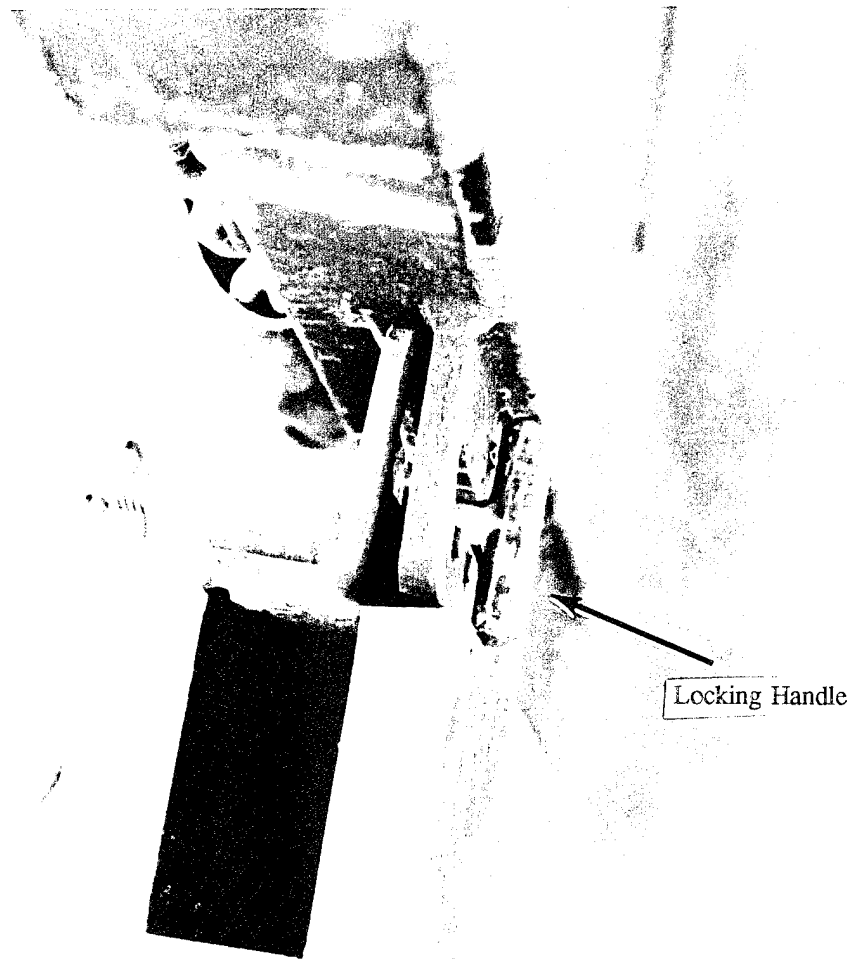

Figure 9. Front dropside to ATC locking handle for part 3.

(MS) calculated for each attachment type, the individual failure mode (i.e., the mode and location most likely to fail first during the applied loading) associated with the MS reported, general comments, and factor-of-safety (FS) values. MS and FS values are calculated from the following equations:

$$MS_{\sigma} = \frac{\sigma_{\text{allowable}}}{\sigma_{\text{calculated}}} - 1$$

$$MS_{\tau} = \frac{\tau_{\text{allowable}}}{\tau_{\text{calculated}}} - 1$$

$$FS_{\sigma} = 6 \frac{\sigma_{\text{allowable}}}{\sigma_{\text{calculated}}}$$

$$FS_{\tau} = \frac{\tau_{\text{allowable}}}{\tau_{\text{calculated}}}$$

(Note: An MS value of 0.0 or less indicates the applied stress is equal to or greater than the allowable stress, or the onset of failure is likely. Similarly, an FS value of less than 1.0 indicates the likelihood of failure.) An FS value of 2.0 or greater is believed to be consistent with current military vehicle design. The allowable stresses were based on ASTM A36 steel that has a yield stress of 36,000 psi. Stress allowables were determined using information gathered from various sources, including the customer at DOL, Fort Richardson, AK. Sketches of the attachments and welding information were provided by the customer and are included in Figures 10–12.

In the initial calculations, the following assumptions were made for modeling simplicity:

- the 5-ton vehicle's side rails were assumed to be a rigid extension of the 5-ton bed;
- the ATC and 5-ton bed, including side rails, were assumed to be rigid bodies and thus absorbed none of the longitudinal acceleration loading;
- the longitudinal forces were distributed equally and statically to each of the six attachments (14,000 lb per attachment, [i.e., the mass of the ATC multiplied by the 30-g acceleration divided among the six attachments]);
- since the ATC's center of gravity (CG) was estimated to be very low, it was assumed that only direct longitudinal forces were transmitted to the attachments and any moments that might be generated by the actual loading acting on the ATC's CG were neglected;
- friction between the ATC's 2.5-ton frame rails and 5-ton cargo bed was neglected;
- clearance between the pins, locking handles, and bolts and the respective attachment parts, was neglected; and
- the "worst-case" direction of the applied longitudinal loading on each attachment was used.

These calculations indicated that the attachment scheme considered was not adequate. All MS/FS values calculated indicated that failure was likely. Initial calculations on transverse and vertical acceleration loadings were not done due to the project's cancellation.

Rear of PC to cargo body tailgate hinge bracket, fabricated from 3/8-in x 2-in steel bar, NSN 9510-00-596-2027, and 1-1/8-in-diameter steel bar, NSN 9510-01-287-9403. Welded on three sides with ER70S-3/EM13K 0.035-in-diameter electrode, NSN 3439-01-013-2800.

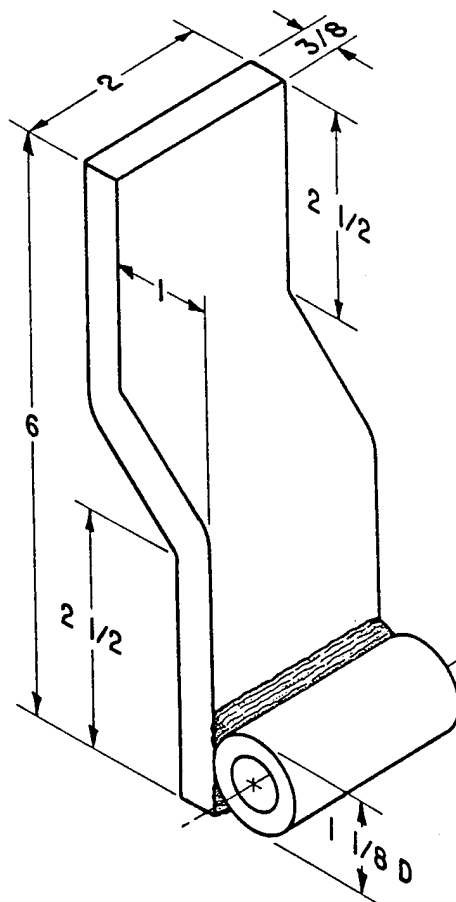
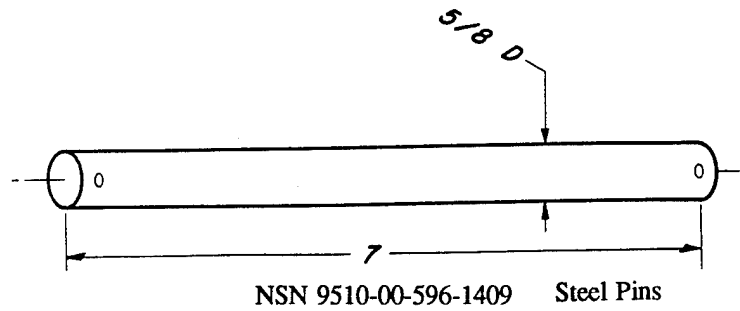

NOTES: All dimensions in inches.
Welding rod specifications: E7018, 70,000 psi.

Figure 10. Sketch of part 1.

Rear dropside to PC attachment bracket, one left side and one right side. Fabricated from steel angle 3 in × 3 in × 3/8 in, NSN 9520-00-288-6070. Welded on four sides with ER70S-3/EM13K 0.035 in diameter.

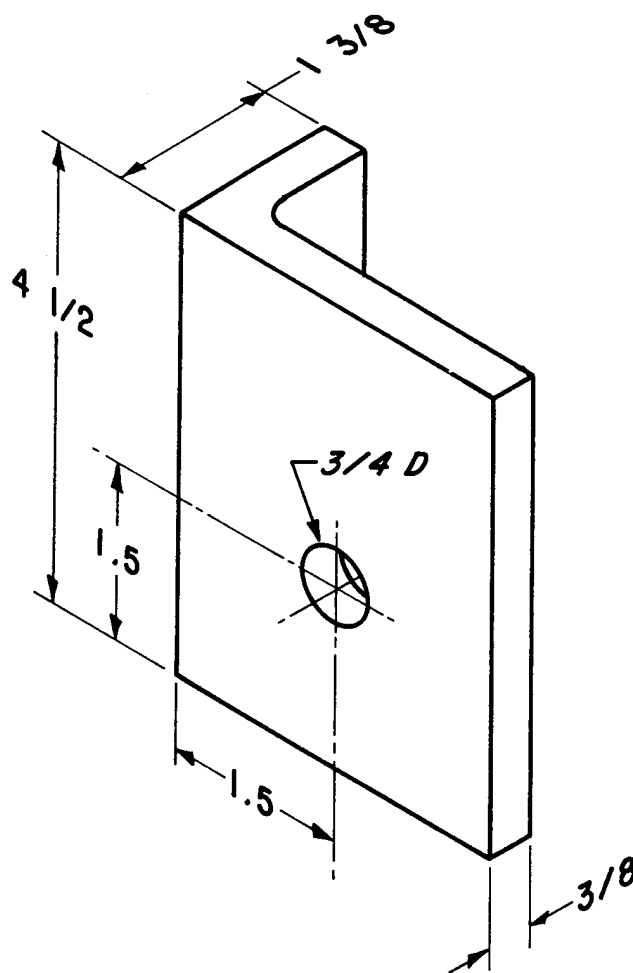

NOTES: All dimensions in inches.
Welding rod specifications: E7018, 70,000 psi.

Figure 11. Sketch of part 2.

Front dropside to PC attachment bracket, one right side and one left side. Fabricated from 2 1/2-in × 2 1/2-in × 3/8-in steel angle, NSN 9520-00-277-4938, and 3/8 in × 3 in steel, flat bar, NSN 9510-00-231-2102. Welded with ER70S-3/EM13K 0.035-in-diameter welding electrode, NSN 3439-01-013-2800.

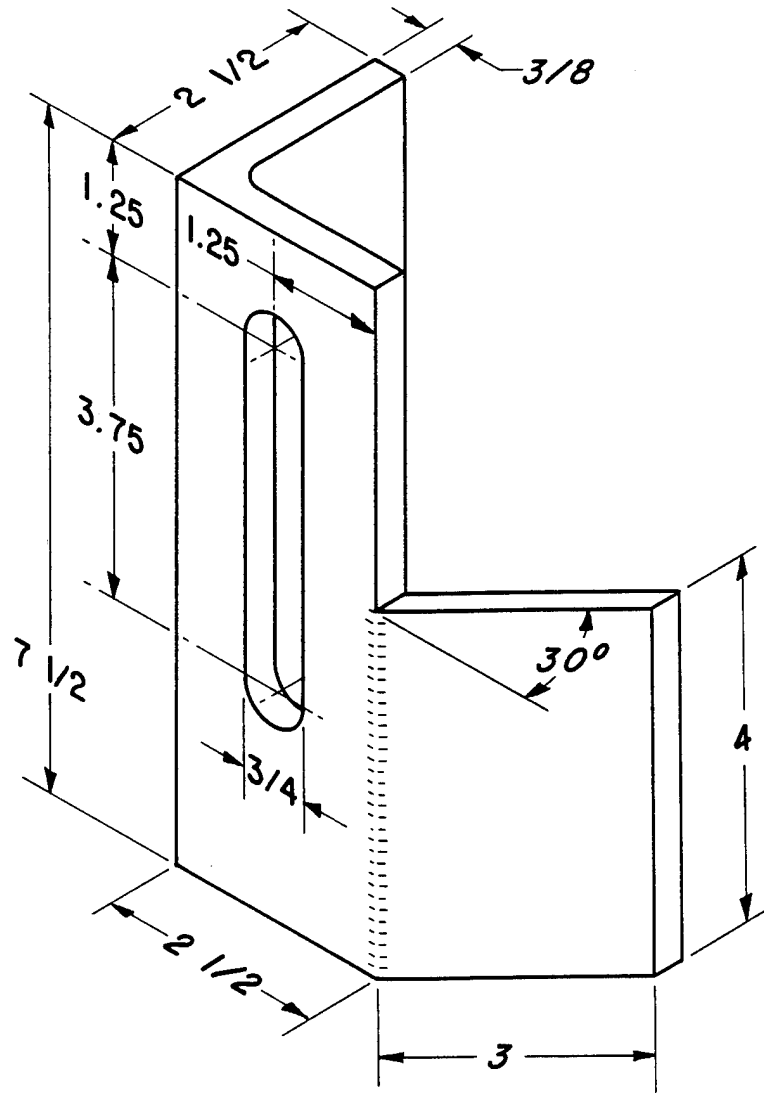

NOTES: All dimensions in inches.
Welding rod specifications: E7018, 70,000 psi.

Figure 12. Sketch of part 3.

2.2 FEA Structural Analysis and Results. FEA was conducted with assumptions similar to those made in the previously listed initial calculations. The basic geometry of the attachments and ATC were implemented in the model (with the aid of 5-ton M923/M939A2 vehicle drawings provided by the U.S. Army Tank Automotive Command [TACOM]). No bolts, pins, or locking handles were modeled for the sake of simplicity. Each attachment was modeled using 8-noded, solid, skewed parallelepiped rectangular elements. The ATC itself has been modeled as a rigid body. The attachments are modeled as being perfectly tied to the ATC rigid body. Elastic material properties of steel were used for all three attachment types in the analysis. Half-symmetry has been used whereby only three of the six attachments were modeled (i.e., one of each of the three attachment types). The symmetry plane is parallel to the longitudinal axis of the ATC. The FEA model, inclusive of attachments and the ATC rigid body, is shown in Figure 13. FEA predicted stresses for each attachment portion modeled are shown in Figures 14–16 as contours of von Mises stress superimposed on the respective attachment model's deformed geometries at maximum loading. The ends of the attachments not connected to the ATC rigid body are longitudinally loaded with a force vs. time history at the locations indicated in Figures 14–16. This force vs. time history was based on the acceleration time history provided by MTMC and is represented in the analysis input as a triangular pulse having a peak of 14,000 lb (30 g loading) and a duration of 0.15 s. (Note: Peak load occurs at 0.075 s.) Note: These loads were applied at the base of part 1 and at the points of contact of the bolt and locking handle connections for parts 2 and 3, respectively. Table 2 summarizes the FEA predicted maximum von Mises stresses, FS corresponding to these stresses and the associated modes of failure in each attachment.

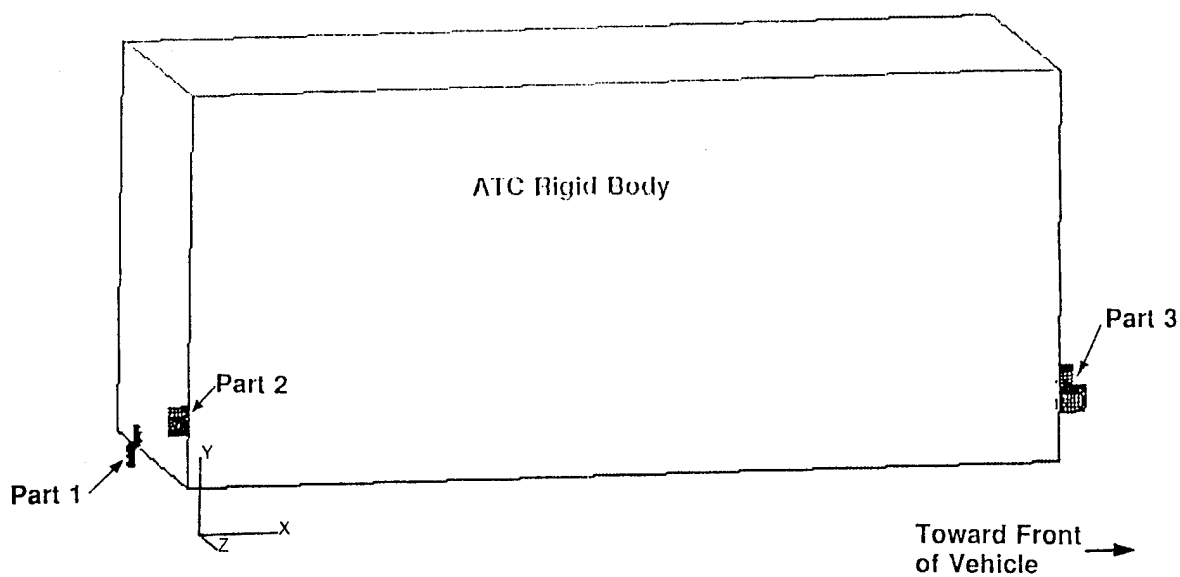

Figure 13. FEA structural model.

Table 2. FEA Predictions at 30-g Longitudinal Acceleration Load Case

Attachment Type	Failure Mode	FEA predicted max. von Mises stress (psi)	FEA predicted FS (yield stress/calculated max. von Mises stress)
Rear of ATC to cargo body (part 1)	Bending stress of upper steel hinge bracket	530,000	0.07
Rear dropside to ATC (part 2)	Bearing stress on steel angle at hole	30,600	1.18
Front dropside to ATC (part 3)	Tension stress on steel angle at bottom of slot	89,000	0.40

3. PROPOSED TESTING

The simulated test plan is reported as follows. Had the project continued, this testing would have been conducted on the attachment (part 1, 2, or 3) that exhibited the lowest FS as verified by FEA. Subsequent tests could have been performed on the other two attachments or on improved attachment concepts.

ATC ATTACHMENT TEST PLAN

Based on the acceleration time histories of 5-ton rail impact testing, the authors have devised a test that should simulate the loadings "seen" by the ATC attachment hardware during rail transport. The acceleration time history of the front cab mount for the 5-ton vehicle, in the longitudinal direction, during an 8.3-mph rail coupling was used (from MTMC 5-ton rail impact test dated 3 December 1991 shown in Figure 17). This acceleration waveform gives a peak acceleration of approximately 24 g (773 ft/s²) over a time interval of approximately 0.15 s, which will be called the half period of the wave form. Using an ATC weight of 2,800 lb, an inertial loading of 67,200 lb is developed on the attaching hardware. The loading is equally distributed among the six attachment pieces for two reasons: 1) due to the fact that the CG of the ATC is sufficiently low that the line of action of the longitudinal forces goes approximately through the centerlines of the hardware and 2) for the sake of simplicity. Hence, each piece of attaching hardware must be capable of handling 11,200 lb of force over a very short time interval. This is an impulsive loading occurring over a time interval of 0.15 s. This can be modeled using a mass/coil spring

fs=7 g=atc20.lta
 Wed Nov 30 08:42:50 EST 1994

terror
 /d/jac/fastjr
 POSTSC.00001
 contour 9

Note:

30 g acceleration loading applied as forces along bottom edge (i.e., edge closest to steel pin) of attachment. (Note, applied forces are acting to the right in the stress plot.)
 Geometry is shown deformed at a displ. scale factor of 1.0.

P3/PATran Neutral File Dyna3d : /d/jac/fastjr/CBC/atc.db 31-Oct-94

TIME = 0.75000E-01

CONTOURS OF EFF. STRESS (V-M)

MIN= 0.202E+04 IN ELEMENT 155
 MAX= 0.530E+06 IN ELEMENT 106

CONTOUR VALUES

- A= 4.64E+04
- B= 1.01E+05
- C= 1.56E+05
- D= 2.11E+05
- E= 2.66E+05
- F= 3.21E+05
- G= 3.76E+05
- H= 4.31E+05
- I= 4.86E+05

(stresses are in psi.)

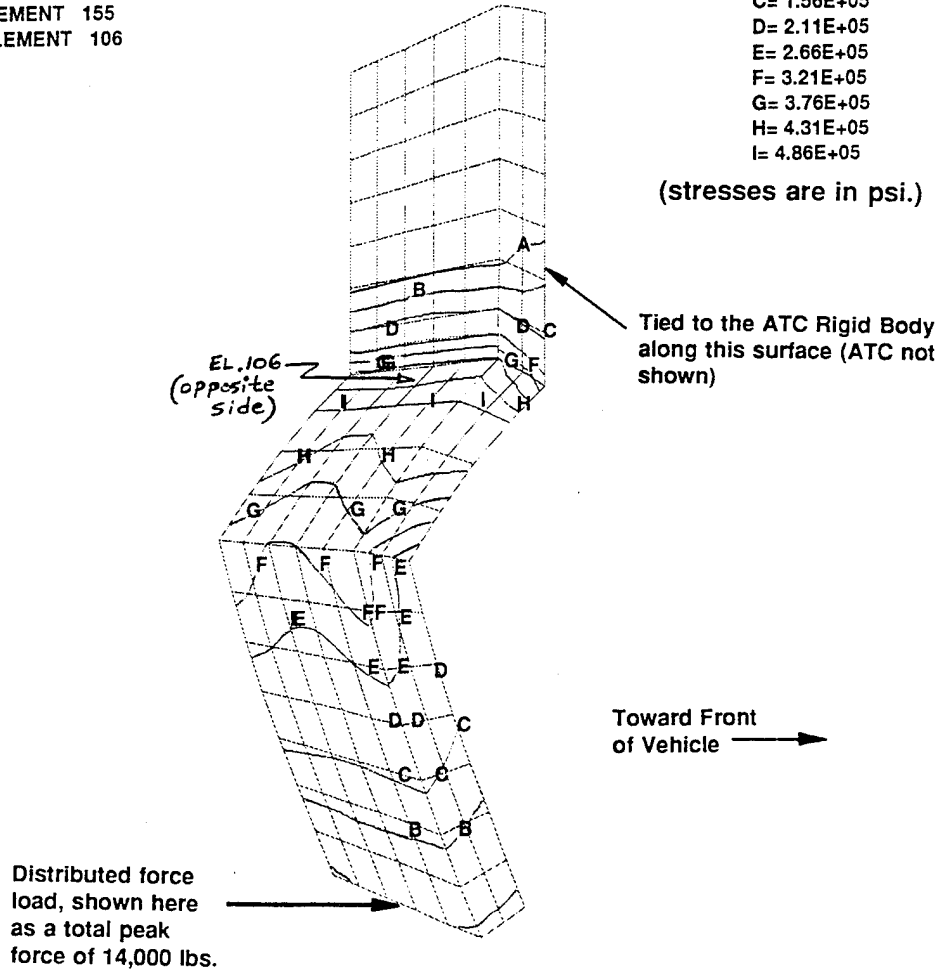

Figure 14. Part 1 model and predicted stresses.

fs=7 g=atc20.ita
Wed Nov 30 08:42:50 EST 1994

terror
/d/jac/fastjr
POSTSC.00013
contour 9

Note:

30 g acceleration loading applied as forces along right semi-circle portion of bolt hole.
(Note, applied forces are acting to the right in the stress plot.)

Geometry is shown deformed at a displ. scale factor of 1.0.

P3/PATRAN Neutral File Dyna3d : /d/jac/fastjr/CBC/atc.db 31-Oct-94

TIME = 0.75000E-01

CONTOURS OF EFF. STRESS (V-M)

MIN= 0.627E+02 IN ELEMENT 301

MAX= 0.306E+05 IN ELEMENT 285

CONTOUR VALUES

A= 2.98E+03

B= 6.51E+03

C= 1.00E+04

D= 1.36E+04

E= 1.71E+04

F= 2.06E+04

G= 2.41E+04

H= 2.77E+04

(stresses are in psi.)

Distributed force load, shown here as a total peak force of 14,000 lbs.

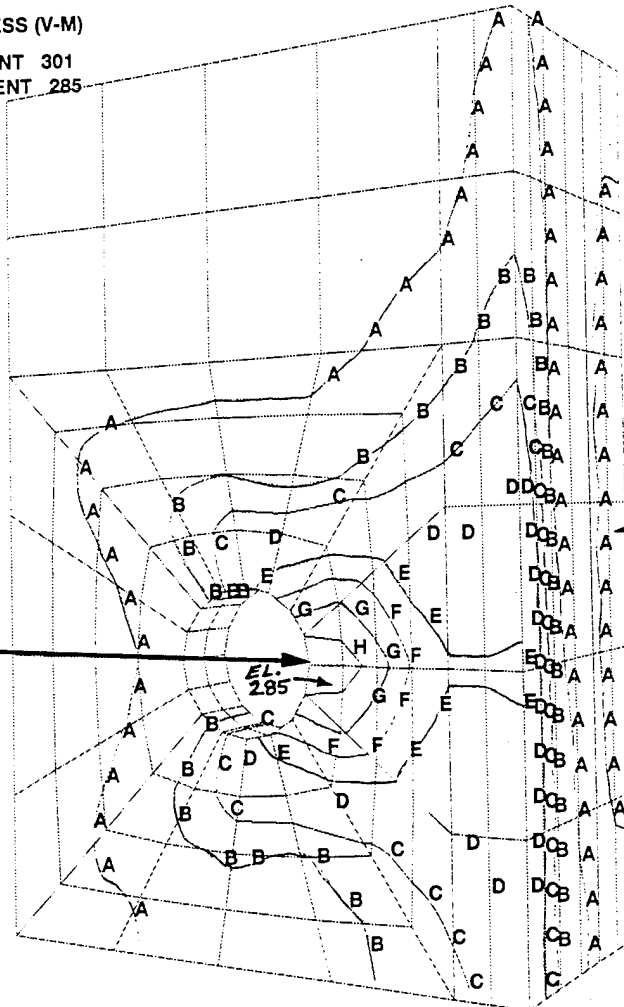

Tied to the ATC Rigid Body along this surface (ATC not shown)

Toward Front of Vehicle →

Figure 15. Part 2 model and predicted stresses.

fs=7 g=atc20.lta
Wed Nov 30 08:42:50 EST 1994

terror
/d/jac/fastjr
POSTSC.00005
contour 9

Note:

30 g acceleration loading applied as forces along right, bottom, quarter-circle portion of locking handle slot. (Note, applied forces are acting to the right in the stress plot and displacements are magnified x100 for clarity.) Geometry is shown deformed at a displ. scale factor of 100.

P3/PATRAN Neutral File Dyna3d : /d/jac/fastjr/CBC/atc.db 31-Oct-94

TIME = 0.75000E-01

CONTOURS OF EFF. STRESS (V-M)

MIN= 0.220E+03 IN ELEMENT 400
MAX= 0.890E+05 IN ELEMENT 474

CONTOUR VALUES

- A= 7.68E+03
- B= 1.69E+04
- C= 2.61E+04
- D= 3.54E+04
- E= 4.46E+04
- F= 5.38E+04
- G= 6.31E+04
- H= 7.23E+04
- I= 8.15E+04

(stresses are in psi.)

Tied to the ATC Rigid Body along this surface (ATC not shown)

Distributed force load, shown here as a total peak force of 14,000 lbs.

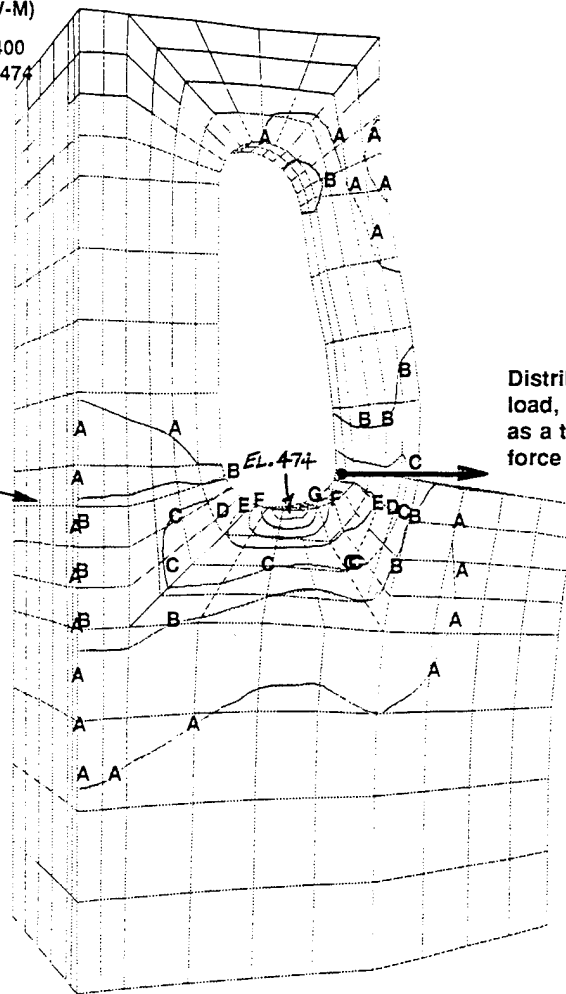

DISP. SCALE FACTOR = 0.100E+03

Figure 16. Part 3 model and predicted stresses.

RAIL IMPACT OF M923 TRUCK

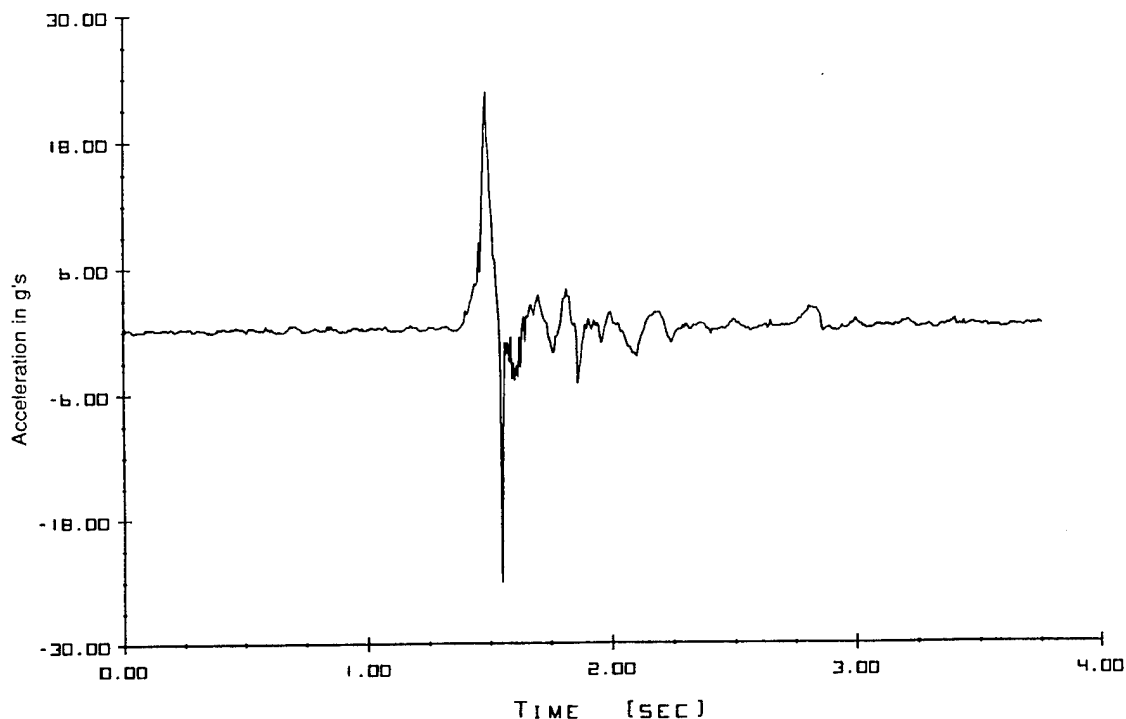

TEST: M923 IMPACT AT 8 MPH FORWARD
 LOCATION: (L) FRT CAB MOUNT
 TRACKS: 1 TO 8

Figure 17. Cab mount acceleration vs. time record.

system as follows. First, the piece of attachment hardware in question will be welded (as per the ATC spec) to a fixed surface (i.e., simulated ATC frame) such that it will be in a position simulating the load path in the actual ATC/attachment configuration. A platform, with a spring of a calibrated load rate, will be attached to the hardware via a pin connection. The platform will be constrained in such a way that it will apply a vertical loading to the hardware. A test object, of sufficient weight, will be dropped from a calculated height so that the object will free fall to gain the velocity needed to impart the specified force to the hardware (see Figure 18).

To get the correct waveform period for the imparted force, we must choose a value for K , the spring constant. From elementary harmonic motion, we have T , the waveform period,

$$T = \frac{2\pi}{\sqrt{\frac{K}{M}}}$$

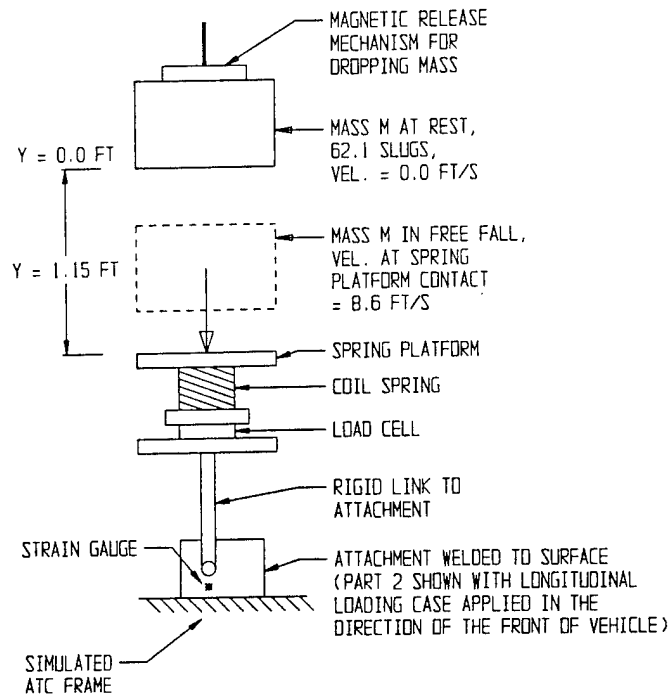

Figure 18. Test setup.

where π , a constant, equals 3.141593, and M is the mass of test object, in this case 62.1 slugs. Since, the half period, $T/2$, and the mass, M , are known, then K can be solved for. Thus, $K = 27,240$ lb/ft or 2,270 lb/in.

To apply the required 11,200 lb of force to the hardware/spring system, the deformation of the spring must be determined via Hooke's Law,

$$F = Kd,$$

where d is deformation of the spring and F is the required load of 11,200 lb. From this, the spring deformation, d , of 0.41 ft is calculated. Now, the potential energy of the spring, PE_s , can be determined with 0.41-ft deformation.

$$PE_s = 0.5Kd^2.$$

Thus, PE_s equates to 2,302.49 lb/ft. Due to conservation of energy, the necessary velocity of the test object can be calculated at the point that it meets the spring platform by equating the potential energy of the spring with the kinetic energy (KE) of the test object.

$$PE_s = KE,$$

where,

$$KE = 0.5MV^2.$$

Thus, if KE equates to 2,302.49 lb/ft, then V is found to be 8.6 ft/s. Making further use of conservation of energy allows the height of the free fall, Y , to be determined by equating the KE of the test object with the gravitational potential energy of the test object.

$$KE = PE_g,$$

where,

$$PE_g = MgY,$$

where g is gravitational acceleration, 32.2 ft/s². Thus, if $PE_g = 2,302.49$ lb/ft, then the height of free fall, Y , is found to be 1.15 ft.

In order to verify, as well as calibrate the test system, a compressive force load cell will be placed between the attachment hardware and the rated coil spring. The load cell will measure the actual force being applied to the hardware. The load cell is rated for up to 50,000 lb (in compression) and has its own spring rate of 22,000,000 lb/in. It has been determined through an analysis of the harmonics of the system, that the spring rate of the load cell is sufficiently high and thus will have a negligible effect upon the dynamics of the test system. In addition, a strain gage will be affixed to the attachment under test. The acquired dynamic strain from the test will provide the necessary validation of the FEA analysis predictions.

4. RECOMMENDATIONS AND CONCLUSIONS

Table 3 lists suggested improvements based on the FEA results for the three attachment types originally proposed. (Details of the improvements are not listed because further analysis would have been necessary.) This work points out deficiencies and suggests simplified corrections. The initial calculations and analysis results reported previously agree fairly well with one another. As a result of this agreement, it is suggested that improvements be made to the original designs to provide an FS of at least 2.0 for each attachment under the worst-case loading condition. This FS value is thought to be typical of military vehicle design.

Table 3. Improvements

Attachment Type	Suggested Improvements
Rear of ATC to cargo body (part 1)	Redesign attachment - original requires large bending stiffness; consider using four of this redesigned type, which would mate to the 5-ton truck tailgate hinge assemblies and/or add gusset reinforcements to the original design.
Rear dropside to ATC (part 2)	Increase thickness of plate in current design and/or use higher strength steel (yield stress > 36 ksi).
Front dropside to ATC (part 3)	Increase thickness of plate in current design and/or use higher strength steel.

It is recommended that additional more detailed analyses, verified by physical testing, be done to optimize the attachment scheme to ensure the best possible solution should the ATC concept be considered. Future prototype design efforts of this type would benefit from a concurrent analysis plan such as the one described in this report. The derived benefits would possibly be a savings in cost and time expenditure.

LIST OF ABBREVIATIONS

ALCOM	-	Alaskan Command
AMC	-	U.S. Army Materiel Command
ARL	-	U.S. Army Research Laboratory
ASTM	-	American Society for Testing and Materials
ATC	-	arctic troop cover
CG	-	center of gravity
CSTA	-	U.S. Army Combat Systems Test Activity
DOL	-	Directorate of Logistics
FEA	-	finite element analysis
FS	-	factor of safety
KE	-	kinetic energy
MS	-	margin of safety
MTMC	-	Military Traffic Management Command
PC	-	personnel carrier
TACOM	-	U.S. Army Tank Automotive Command

INTENTIONALLY LEFT BLANK.

NO. OF
COPIES ORGANIZATION

2 DEFENSE TECHNICAL INFO CTR
ATTN DTIC DDA
8725 JOHN J KINGMAN RD
STE 0944
FT BELVOIR VA 22060-6218

1 DIRECTOR
US ARMY RESEARCH LAB
ATTN AMSRL OP SD TA
2800 POWDER MILL RD
ADELPHI MD 20783-1145

3 DIRECTOR
US ARMY RESEARCH LAB
ATTN AMSRL OP SD TL
2800 POWDER MILL RD
ADELPHI MD 20783-1145

1 DIRECTOR
US ARMY RESEARCH LAB
ATTN AMSRL OP SD TP
2800 POWDER MILL RD
ADELPHI MD 20783-1145

ABERDEEN PROVING GROUND

5 DIR USARL
ATTN AMSRL OP AP L (305)

<u>NO. OF COPIES</u>	<u>ORGANIZATION</u>	<u>NO. OF COPIES</u>	<u>ORGANIZATION</u>
1	DIRECTOR AMC FIELD ASSISTANCE IN SCIENCE & TCHNLGY ACTVTY 5985 WILSON RD STE 100 FT BELVOIR VA 22060-5829	1	US TRANSPORTATION CMD ATTN TCCC XI A G KASSOS 508 SCOT DR SCOTT AFB IL 62225-5357
1	US ARMY JAPAN IX CORPS ATTN APAJ SA M BOENKER UNIT 45005 APO AP 96343-0054	1	HQS USFK EUSA SCIENCE ADVISER OFC ATTN FKCS SO J KOH UNIT 15236 APO AP 96205-0010
1	US ARMY PACIFIC ATTN APSA C CAMPAGNUOLO FT SHAFTER HI 96858-5100	1	USA NATL TRAINING CTR ATTN AMXLA SA S KOHNKE BLDG 502 FT IRWIN CA 92310
1	HQ USASETAF ATTN AESE SA G D'ANDREA UNIT 31401 BOX 72 BLDG 33 APO AE 09630	1	USA TRADOC ATTN ATCD B R T KOHOUT UNIT 15236 FT MONROE VA 23651-5000
1	HQ USAEUR & 7TH ARMY OFC OF THE SCI ADVISER ATTN AEAGX SA M FALK UNIT 29351 APO AE 09014	1	HQ SPECIAL OPS CMD ATTN SOSD S M MILLER 7701 TAMPA POINT BLVD MACDILL AFB FL 33621-5323
1	HQ USFK EUSA SCIENCE ADVISER OFC ATTN FKCS SO D GIORDANO UNIT 15236 APO AP 96205-0010	1	HQ FORCES CMD ATTN AFCS SA T REYNOLDS FT MCPHERSON GA 30330-6000
1	ALASKAN COMMAND ATTN 11OG OC J P GRILLS 6-900 9TH ST STE 110 ELMENDORF AFB AK 99506-2230	1	I CORPS & FT LEWIS ATTN AFZH CSS E SCHILLER BLDG 2025 RM 124 FT LEWIS WA 98433-5000
1	HQ V CORPS COMMAND GROUP ATTN AETV SA J HALPIN UNIT 25202 APO AE 09079-0700	1	XVIII ABN AND FT BRAGG SCIENCE ADVISER OFC ATTN AFZA CS S D SMITH FT BRAGG NC 28307-5000
1	HQ III CORPS & FT HOOD SCIENCE ADVISER OFC ATTN AFZF CS SA R J HOLLEY FT HOOD TX 76544-5056	1	HQ 7TH ARMY TRAINING CMD ATTN AETT SA J SMITH UNIT 28130 APO AE 09114

<u>NO. OF COPIES</u>	<u>ORGANIZATION</u>
1	SOUTHCOM WASHINGTON FIELD OFC ATTN L STANTON 1919 S EADS ST STE 109 ARLINGTON VA 22202
1	HQ EUCOM ATTN E ZACHARKEVICS UNIT 30400 BOX 138 APO AE 09128

<u>NO. OF COPIES</u>	<u>ORGANIZATION</u>
	<u>ABERDEEN PROVING GROUND</u>
10	DIR, USARL ATTN: AMSRL-WT, DR. I. MAY AMSRL-WT-W, DR. C. MURPHY AMSRL-WT-WB, MR. M. HOLLIS AMSRL-WT-WE, MS. J. LACETERA MR. W. JOHNSON MR. P. FAZIO (3 CP) AMSRL-TB, DR. R. FREY MR. F. H. GREGORY

INTENTIONALLY LEFT BLANK.

USER EVALUATION SHEET/CHANGE OF ADDRESS

This Laboratory undertakes a continuing effort to improve the quality of the reports it publishes. Your comments/answers to the items/questions below will aid us in our efforts.

1. ARL Report Number ARL-MR-274 Date of Report November 1995

2. Date Report Received _____

3. Does this report satisfy a need? (Comment on purpose, related project, or other area of interest for which the report will be used.) _____

4. Specifically, how is the report being used? (Information source, design data, procedure, source of ideas, etc.) _____

5. Has the information in this report led to any quantitative savings as far as man-hours or dollars saved, operating costs avoided, or efficiencies achieved, etc? If so, please elaborate. _____

6. General Comments. What do you think should be changed to improve future reports? (Indicate changes to organization, technical content, format, etc.) _____

CURRENT
ADDRESS

Organization

Name

Street or P.O. Box No.

City, State, Zip Code

7. If indicating a Change of Address or Address Correction, please provide the Current or Correct address above and the Old or Incorrect address below.

OLD
ADDRESS

Organization

Name

Street or P.O. Box No.

City, State, Zip Code

(Remove this sheet, fold as indicated, tape closed, and mail.)
(DO NOT STAPLE)

DEPARTMENT OF THE ARMY

OFFICIAL BUSINESS

BUSINESS REPLY MAIL

FIRST CLASS PERMIT NO 0001, APG, MD

POSTAGE WILL BE PAID BY ADDRESSEE

DIRECTOR
U.S. ARMY RESEARCH LABORATORY
ATTN: AMSRL-WT-WE
ABERDEEN PROVING GROUND, MD 21005-5066

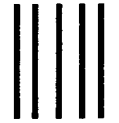

NO POSTAGE
NECESSARY
IF MAILED
IN THE
UNITED STATES

