

NASA  
Technical  
Paper  
1981

March 1982

Design Detail Verification  
Tests for a Lightly  
Loaded Open-Corrugation  
Graphite-Epoxy Cylinder

Randall C. Davis  
and James H. Starnes, Jr.

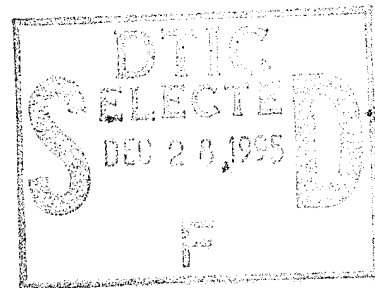

DEPARTMENT OF DEFENSE  
ASTICS TECHNICAL EVALUATION  
SERVICES, ROOM 11, 400

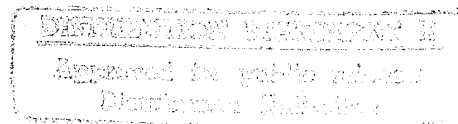

19951220 036

DTIC QUALITY INSPECTED

NASA

POSTED  
19951220

1982

# Design Detail Verification Tests for a Lightly Loaded Open-Corrugation Graphite-Epoxy Cylinder

Randall C. Davis  
and James H. Starnes, Jr.  
*Langley Research Center  
Hampton, Virginia*

Accession For	
NTIS CRA&I	<input checked="" type="checkbox"/>
DTIC TAB	<input type="checkbox"/>
Unannounced	<input type="checkbox"/>
Justification _____	
By _____	
Distribution/	
Availability Codes	
Dist	Avail and/or Special
A-1	



National Aeronautics  
and Space Administration

Scientific and Technical  
Information Branch

The use of trade names in this publication does not constitute endorsement, either expressed or implied, by the National Aeronautics and Space Administration.

## SUMMARY

Flat corrugated graphite-epoxy panels were tested in compression to verify selected design details of a ring-stiffened cylinder that was designed to support an axial compressive load of 157.6 kN/m without buckling. Three different sizes of subcomponent panels were tested to verify (1) the buckling strength of the shell wall between rings, (2) the load-introduction method at the cylinder edges, (3) the effect of a longitudinal joint in the cylinder wall on the buckling behavior, and (4) the strength of the ring-attachment method. The shell-wall design was modified to prevent premature crown buckling and the results of subsequent tests indicate that the modified shell-wall design, the longitudinal joint, the load-introduction method, and the stiffener-attachment method for the proposed cylinder have adequate strength to support the design load.

## INTRODUCTION

Minimum-mass structural-sizing computer codes (refs. 1 and 2) can provide preliminary designs for structures that are required to support a desired load without buckling and can satisfy constraints imposed by the designer. However, nonlinear modal interactions as well as the effects of geometric variations not included in the designer's original constraints could lead to premature buckling. Lightly loaded structures become especially sensitive to these geometric and nonlinear effects (ref. 3) because they have thin gage sections. One such lightly loaded structure with very thin wall dimensions is an open-corrugation graphite-epoxy ring-stiffened cylindrical shell; it was designed by using a minimum-mass structural-sizing code to support 157.6 kN/m in axial compression without buckling. The constraints imposed on the design include local buckling of the corrugation crowns and webs, panel-type buckling between rings, general instability of the ring-stiffened cylinder, minimum gage, and maximum strain. Details of the cylinder design and of the fabrication process are given in references 4 to 6. To verify selected details of the cylinder design, three different sizes of subcomponent panels, with the same basic corrugation geometry, were tested: (1) 60.96-cm-long by 45.72-cm-wide panels to evaluate the local buckling strength of the shell-wall design, (2) 91.44-cm-long by 45.72-cm-wide panels to evaluate a longitudinal joint and the load-introduction method, and (3) 254.0-cm-long by 91.44-cm-wide panels with four simulated-ring stiffeners to evaluate the ring-attachment method. The results of these tests are presented in this report.

## TEST SPECIMENS

The panels tested in this investigation were fabricated from commercially available graphite-epoxy preimpregnated tapes. The tapes were made of unidirectional Union Carbide Thornel 300 graphite fibers preimpregnated with Narmco 5208 epoxy resin. Nominal ply properties for this material are given in table 1 and more extensive material and mechanical property data for the panels are found in references 4 through 6.

## Shell-Wall Panels

Four 60.96-cm-long by 45.72-cm-wide shell-wall panels were tested to assess the local buckling strength of the shell-wall design. Two of these panels, designated 1-24 and 2-24, were built to the preliminary design specifications generated by a minimum-mass structural-sizing code. These two panels had four 0° plies in the corrugation crowns and the geometry is shown in figure 1(a). The remaining two shell-wall panels, designated 3-24 and 4-24, had five 0° plies in the corrugation crowns as indicated in figure 1(b). A photograph of a typical shell-wall panel appears as figure 2.

## Longitudinal-Joint and Load-Introduction Panels

Two 91.44-cm-long by 45.72-cm-wide longitudinal-joint and load-introduction panels, designated 1-36 and 2-36, were fabricated with five 0° plies in the corrugation crowns as shown in figure 1(b). Geometric details of these panels are shown in figure 3 and a photograph of a typical specimen is shown as figure 4. There were two principal objectives in testing these panels: The first was to evaluate the strength and stiffness of a longitudinal joint in one of the corrugation crowns and the second was to verify the integrity of the load-introduction method used to transfer the load into the corrugated wall.

To make the longitudinal joint, a room-temperature-curing adhesive and fiber-glass cloth with no 0° graphite-epoxy plies were used. Glass cloth was used to match the stiffness of the corrugation crown with the joint to the stiffness of the other crowns without joints. Details of the longitudinal joint are given in references 4 to 6 and shown in figure 3.

To verify the integrity of the load-introduction method, scalloped aluminum load-introduction fixtures were bolted to the corrugation crowns (fig. 3) in order to transfer the applied edge load to the corrugated shell wall. The crowns under the load-introduction fixtures were reinforced with additional 0° graphite-epoxy plies that tapered down to the basic shell-wall geometry as shown in figure 3 and described in references 4 through 6.

## Stiffened Panels

Two 254.0-cm-long by 91.44-cm-wide stiffened corrugated panels, designated 1-100 and 2-100, were tested to evaluate the ring-attachment method. Geometric details of the panels are shown in figure 5 and a photograph of a representative panel is presented as figure 6. The stiffeners were riveted and bonded to the corrugation crowns as described in reference 4. These test specimens were designed to have buckling modes characteristic of the general instability modes of the cylinder.

## APPARATUS AND TESTS

The ends of panels 1-24 through 4-24 and panels 1-100 and 2-100 were potted in an aluminum-filled epoxy and then machined flat and parallel. The scalloped aluminum load-introduction fixtures attached to the loaded ends of panels 1-36 and 2-36 were machined flat and parallel. The flat ends of the panels were loaded by a hydraulically controlled displacement of the test machine platens. At about 10 percent of design load, the upper test-machine platen was aligned with the test

specimens until the longitudinal strains at the midlength of the panel were within a few percent of each other. A survey of the test results at 50 percent of design load on a typical panel showed that the strains across the midlength of the panel were within  $\pm 5$  percent of the average strain.

The unloaded edges of panels 1-24 through 4-24 and 1-36 and 2-36 were supported by full-length knife-edge fixtures that provided a simple-support edge condition. However, the unloaded edges of panels 1-100 and 2-100 were supported by knife-edge fixtures located between the simulated-ring stiffeners to provide a simple-support condition for the panel edges between stiffeners. The ends of the stiffeners that protruded beyond the panel edges were supported by a single full-length knife-edge fixture on each side of the panel. Additional restraints were applied to the center of each stiffener on both panels and at the stiffener quarter points of panel 1-100 to ensure that the panels buckled into a mode representative of the expected general instability mode of the cylinder.

Specimen end shortening was measured with direct current displacement transducers. Electrical resistance strain gages were used to monitor longitudinal strains. A moiré-fringe procedure was used to observe the buckling mode pattern of the panel surface. The load, end shortening, and all strain-gage readings were recorded by an electronic data acquisition system.

## RESULTS AND DISCUSSION

The results from the tests of the eight panels are summarized in table 2. The initial buckling loads, determined by using the strain reversal method, are given in the table normalized by the design load of 157.6 kN/m. The longitudinal stiffness (load per unit width divided by strain) was determined from the average of the slopes of the load-strain curves obtained from strain gages at the midlength of each panel; these values are given in table 2. The values of mass per unit area for each panel are also given in the table. The values of mass per unit area given for panels 1-36 and 2-36 include the joint materials and rivets as well as the reinforcing material at the ends of the panels but do not include the scalloped aluminum load-introduction fixtures. For panels 1-100 and 2-100, the stiffeners and rivets are included in the mass values.

### Shell-Wall Panels

The test results from the first two shell-wall panels, 1-24 and 2-24, indicate that the corrugation crown design with four  $0^\circ$  plies in the crowns buckled locally at 74 and 78 percent of the desired design load. (See table 2.) Back-to-back strain-gage and end-shortening data, typical of these two panels, are shown in figures 7 and 8, and moiré-fringe patterns for the buckled corrugation crowns are shown in figure 9. Local bending about the crown midsurface begins at a low load level for some parts of the crowns and grows until strain reversal occurs as shown by the back-to-back strain-gage response curves in figure 7. These local buckle modes in the crowns cause a decrease in the overall panel longitudinal stiffness which causes the panel to buckle at a load below the design load as indicated by the change in slope of the load-deflection curve in figure 8. Loading for these two panels was stopped at 88 and 86 percent of the design load because of large local deformations at the panel edges between the side support fixture and the end potting material.

Thickness measurements of the corrugation crown cross sections in panels 1-24 and 2-24 revealed that the curing process caused thinner crowns than anticipated. As a result of the applied pressure during the curing process, the 0° plies, unlike the 45° cross plies (see fig. 1), were pressed into one another; thereby the thickness of the 0° material was reduced. The layer of 0° plies (shown cross-hatched in the sketches) became thinner and wider than the idealized design represented by sketch A. The encapsulated 0° material tapered to a point at its edges and pushed out between the  $\pm 45^\circ$  outer plies as indicated in sketch B. Using the as-fabricated cross section with the thinner and wider layers of 0° plies, BOSOR4 (ref. 7) buckling analyses suggested that the reduced bending stiffness in the crowns caused the premature local buckling to occur. Therefore, the BOSOR4 results indicate that the buckling loads of these thin-gage structural components are sensitive to minor thickness variations.

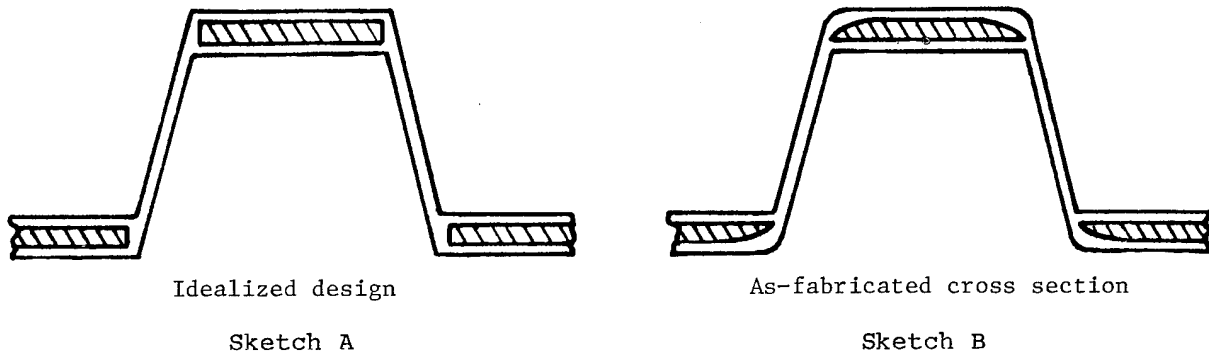

Panels 3-24 and 4-24 were fabricated with an additional 0° ply in each crown (fig. 1(b)) to offset the thinning of the 0° plies and to raise the local buckling strength of the corrugation crowns. An additional modification incorporated in this refined corrugation crown design was a minor increase in the width of the 0° plies to reduce the amount of taper at the edges of the 0° material. Typical results for the shell-wall panels with five 0° plies in the crowns are shown in figures 10, 11, and 12. The results for shell-wall panels 3-24 and 4-24 show that the crown corrugation design with five 0° plies raises the initial crown buckling strength to 95 and 93 percent of the design load, respectively. The resulting increase in overall panel stiffness allowed the panels to carry loads above the design load (panel 3-24 was loaded to 106 percent of design load and panel 4-24 failed at 116 percent of design load). These changes to the corrugation crown design were also incorporated into the longitudinal-joint and load-introduction panels and the stiffened panels.

#### Longitudinal-Joint and Load-Introduction Panels

Results typical of the longitudinal-joint and load-introduction panels are shown in figures 13 and 14. These results indicate that the longitudinal-joint and load-introduction panels have response characteristics similar to shell-wall panels with the improved design. The corrugation crowns of panels 1-36 and 2-36 buckled at 104 and 103 percent of the design load and the maximum loads applied to these panels were 121 and 130 percent, respectively. The results (table 2) indicate that the longitudinal joint has little effect on the panel longitudinal stiffness, and the longitudinal-joint and load-introduction design will support the design load without strength failures.

## Stiffened Panels

Results of the two stiffened panel tests indicate that panel buckling occurred at 94 and 84 percent of the design load. Typical strain-gage and end-shortening data for panel 1-100 are shown in figures 15 and 16. The response of the back-to-back strain-gage pairs indicates that the panel buckles without any evidence of local buckling of the corrugation crowns. These results suggest that the restraint provided by the stiffeners is less than the restraint provided by the end conditions of the shorter shell-wall panels. After initial buckling occurred, large local deformations at the edge support fixtures of panels 1-100 and 2-100 caused local material failures to propagate across the panels at approximately 98 and 92 percent of the design load, respectively. There were no indications of any ring-attachment failures for these tests; therefore, the ring-attachment method should be expected to perform satisfactorily at the design load.

## CONCLUDING REMARKS

Three sizes of flat open-corrugation graphite-epoxy panels were tested to verify selected structural design details of a ring-stiffened corrugated cylinder. The cylinder was designed to support an axial compressive load of 157.6 kN/m without buckling. The test results indicate that the buckling load of the thin-gage corrugation crown design is sensitive to small thickness variations associated with the fabrication process. The shell-wall design was modified to prevent premature crown buckling, and the results of subsequent tests indicate that the modified shell-wall design, the longitudinal joint, the load-introduction method, and the stiffener-attachment method for the proposed cylinder have adequate strength to support the design load.

Langley Research Center  
National Aeronautics and Space Administration  
Hampton, VA 23665  
February 16, 1982

#### REFERENCES

1. Agarwal, Banarsi; and Davis, Randall C.: Minimum-Weight Designs for Hat-Stiffened Composite Panels Under Uniaxial Compression. NASA TN D-7779, 1974.
2. Anderson, Melvin S.; and Stroud, W. Jefferson: A General Panel Sizing Computer Code and Its Applications to Composite Structural Panels. AIAA J., vol. 17, no. 8, Aug. 1979, pp. 892-897.
3. Williams, Jerry G.; and Mikulas, Martin M., Jr.: Analytical and Experimental Study of Structurally Efficient Composite Hat-Stiffened Panels Loaded in Axial Compression. NASA TM X-72813, 1976. (Also available as AIAA Paper No. 75-754.)
4. Johnson, Read, Jr.: Design and Fabrication of a Ring-Stiffened Graphite-Epoxy Corrugated Cylindrical Shell. NASA CR-3026, 1978.
5. Johnson, Read, Jr.; Reck, R. J.; and Davis, Randall C.: Design and Fabrication of a Large Graphite-Epoxy Cylindrical Shell. A Collection of Technical Papers - AIAA/ASME 19th Structures, Structural Dynamics and Materials Conference, AIAA, c.1978, pp. 300-310. (Available as AIAA Paper 78-507.)
6. Penton, A. P.; Johnson, R., Jr.; and Freeman, V. L.: Fabrication of Composite Shell Structure for Advanced Space Transportation. Selective Applications of Materials for Products and Energy, Volume 23 of National SAMPE Symposium and Exhibition, Soc. Advance. Mater. & Process Eng., c.1978, pp. 137-149.
7. Bushnell, David: Stress, Stability, and Vibration of Complex Branched Shells of Revolution: Analysis and User's Manual for BOSOR4. NASA CR-2116, 1972.

TABLE 1.- LAMINA MATERIAL PROPERTIES

Lamina thickness, cm .....	0.014
Modulus in fiber direction, GN/m <sup>2</sup> .....	131.0
Modulus in transverse direction, GN/m <sup>2</sup> .....	13.0
Lamina shear modulus, GN/m <sup>2</sup> .....	6.41
Major Poisson's ratio .....	0.380
Lamina density, kg/m <sup>3</sup> .....	1522

TABLE 2.- SUMMARY OF TEST RESULTS

Panel	Crown thickness, cm	<u>Initial buckling load</u> Design load <sup>a</sup>	<u>Load per unit width</u> Strain, MN/m	Mass per unit area, kg/m <sup>2</sup>
1-24	0.109	0.74	64.8	1.47
2-24	.107	.78	63.0	1.32
3-24	.120	.95	73.6	1.62
4-24	.120	.93	71.8	1.58
1-36	0.127	1.04	71.8	<sup>b</sup> 2.45
2-36	.127	1.03	71.8	<sup>b</sup> 2.39
1-100	0.125	0.94	73.6	<sup>c</sup> 2.22
2-100	.129	.84	73.6	<sup>c</sup> 2.03

<sup>a</sup>Design load equals 157.6 kN/m.

<sup>b</sup>Includes mass of joint materials and rivets as well as reinforcing material at end of panel.

<sup>c</sup>Includes mass of stiffeners and rivets.

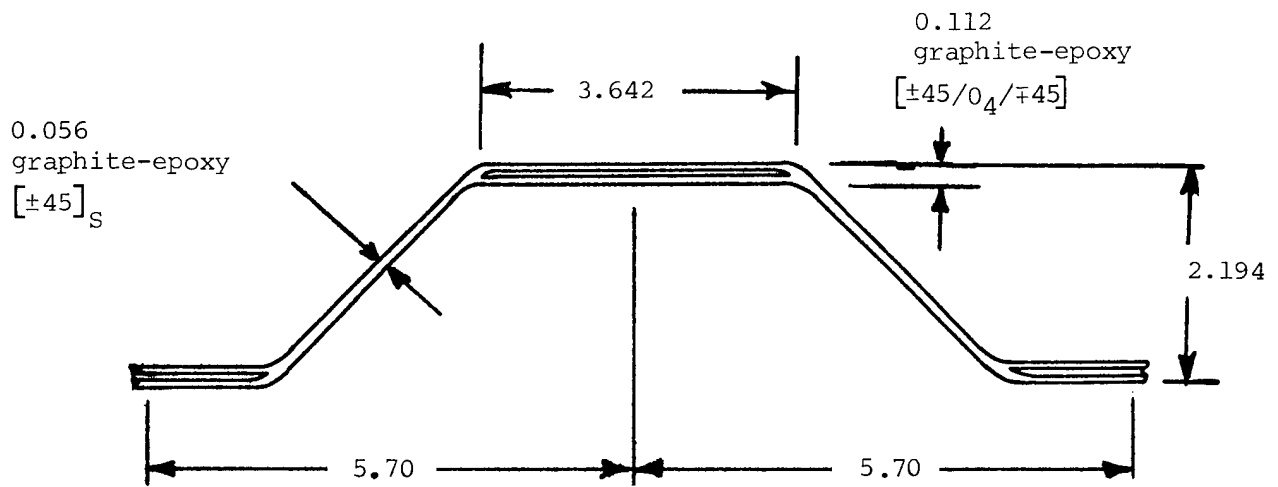

(a) Crown configuration with four 0° plies (panels 1-24 and 2-24).

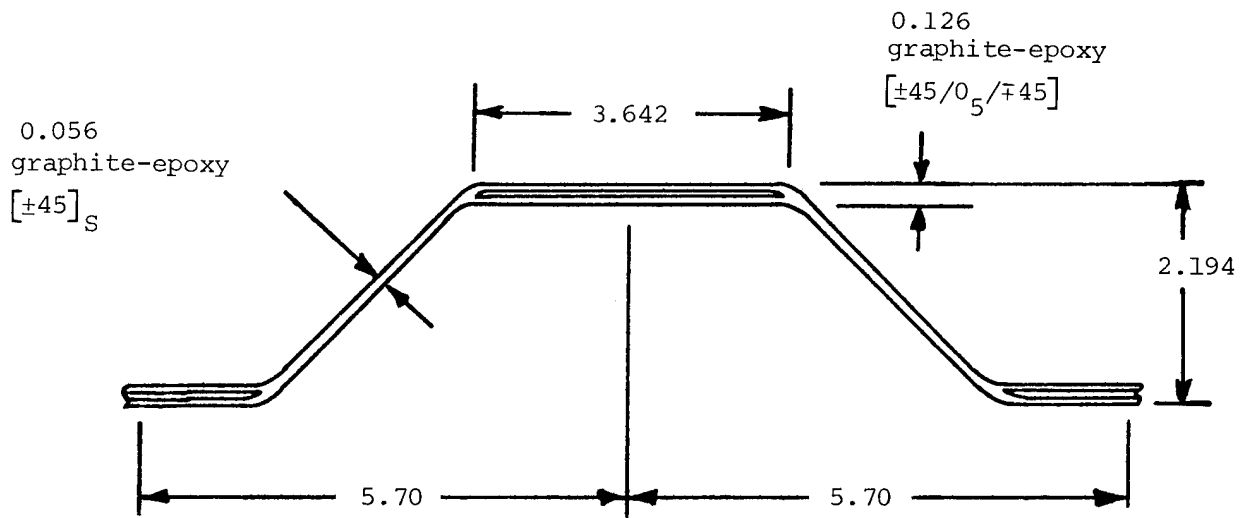

(b) Crown configuration with five 0° plies (panels 3-24 and 4-24, 1-36 and 2-36, and 1-100 and 2-100).

Figure 1.- Corrugation cross-section geometric details.  
Dimensions are in centimeters.

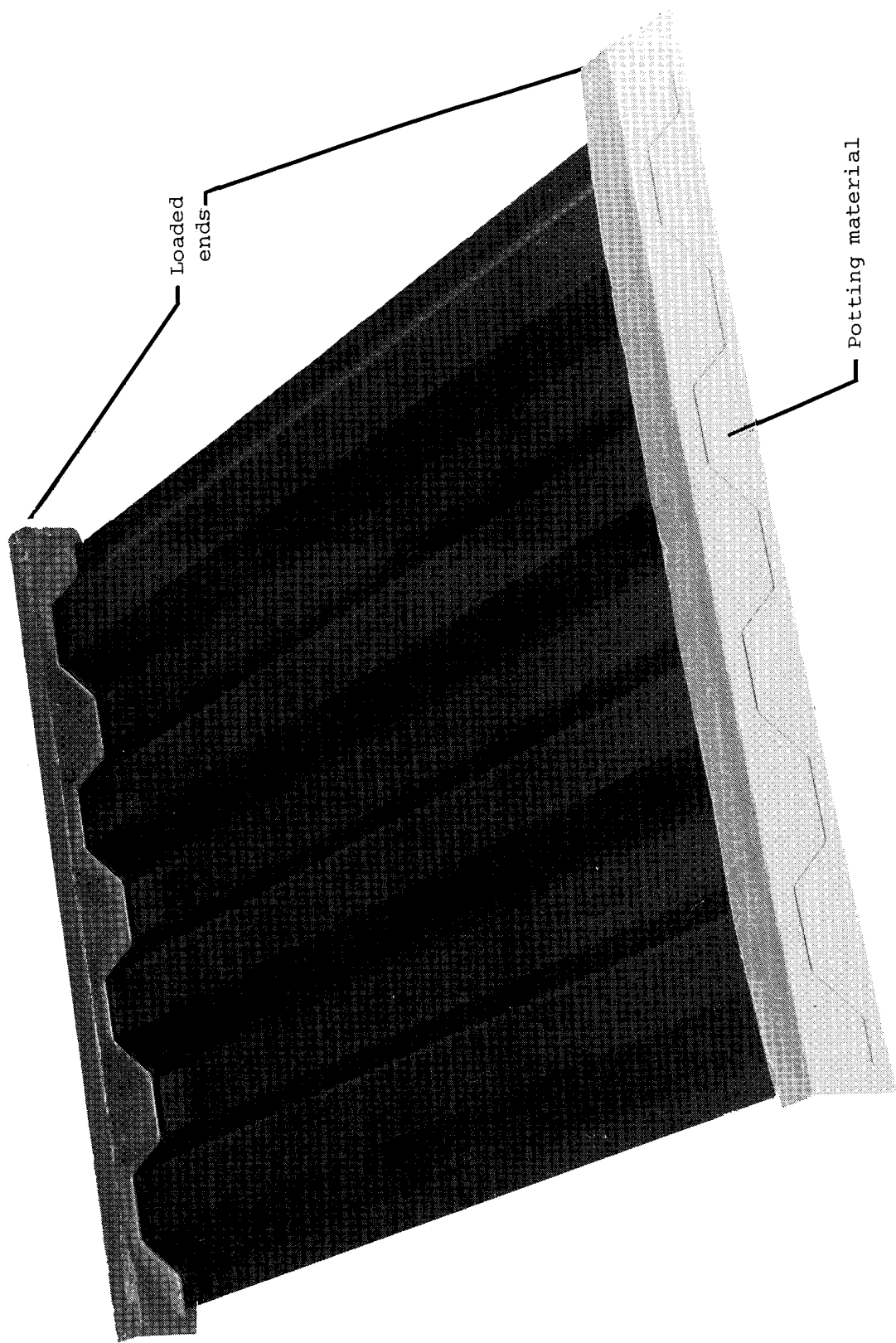

L-82-110

Figure 2.- Typical 60.96-cm-long compression test panel.

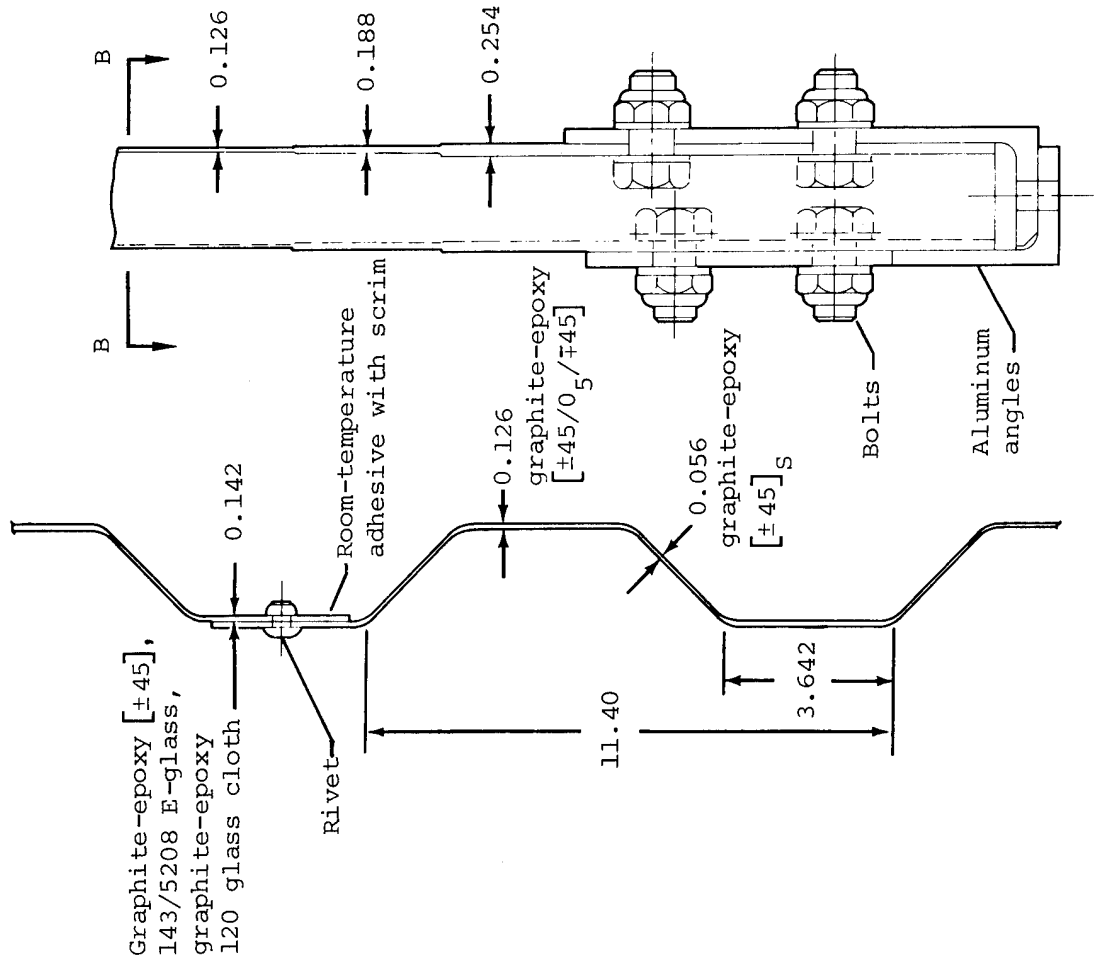
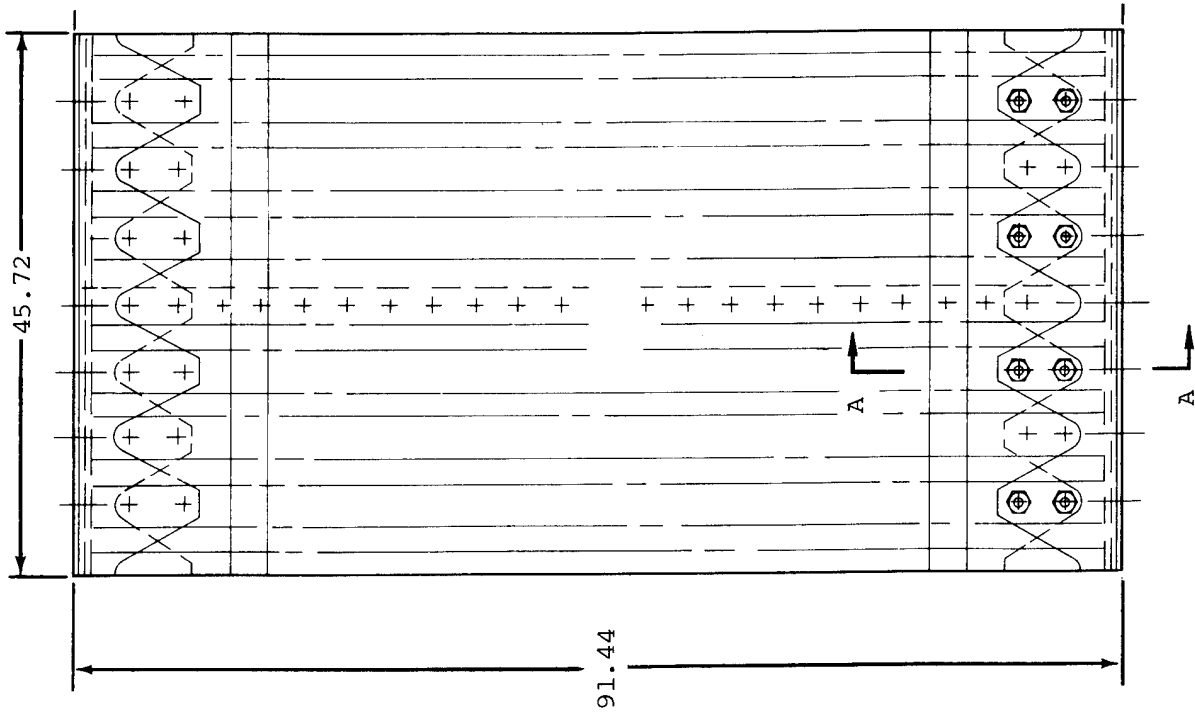

Section A-A

Section B-B

Figure 3.- Geometric details of 91.44-cm-long panels with longitudinal-joint and load-introduction fixtures. Dimensions are in centimeters.

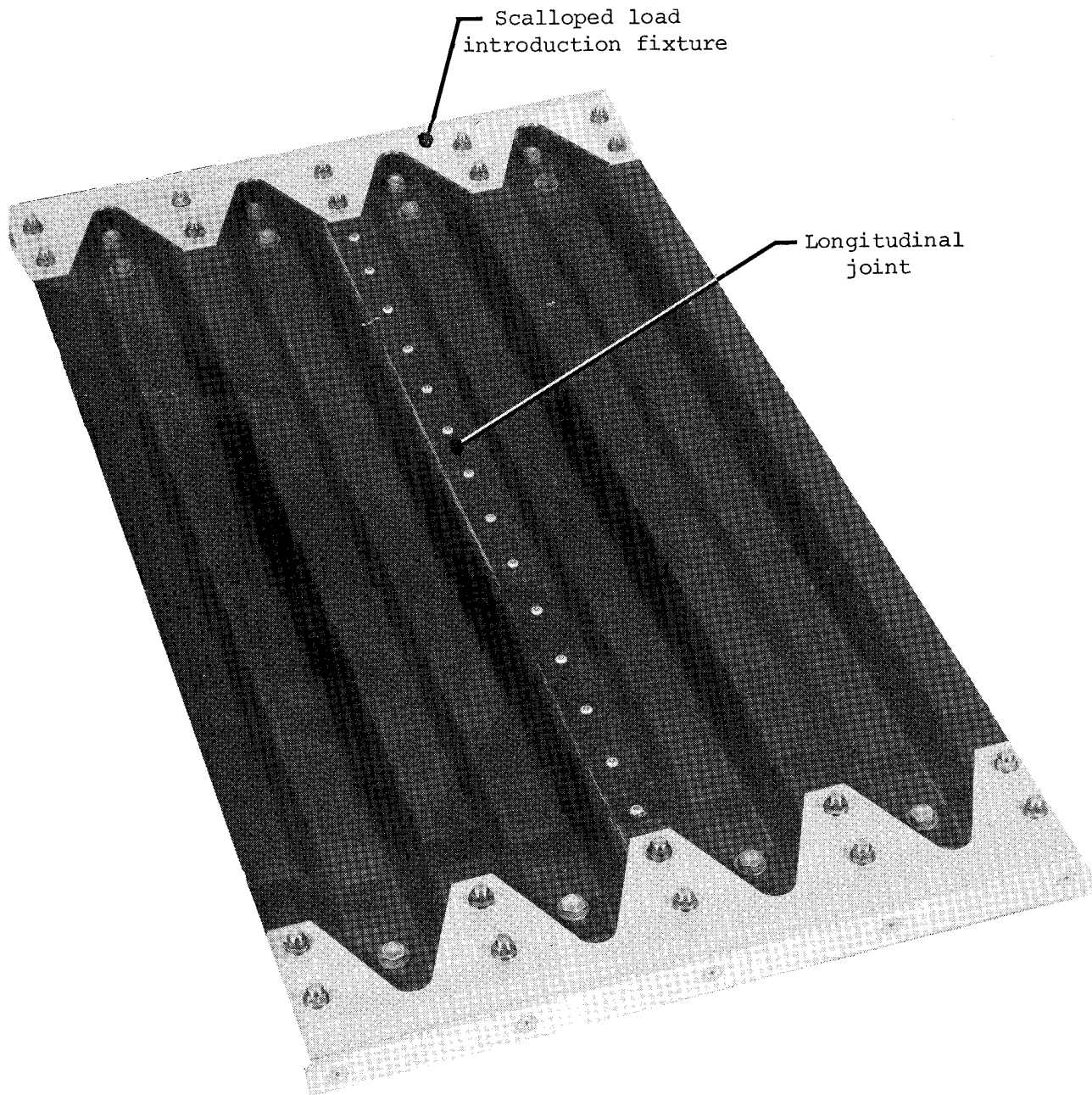

L-82-111

Figure 4.- Typical 91.44-cm-long test panel with longitudinal-joint and load-introduction fixtures.

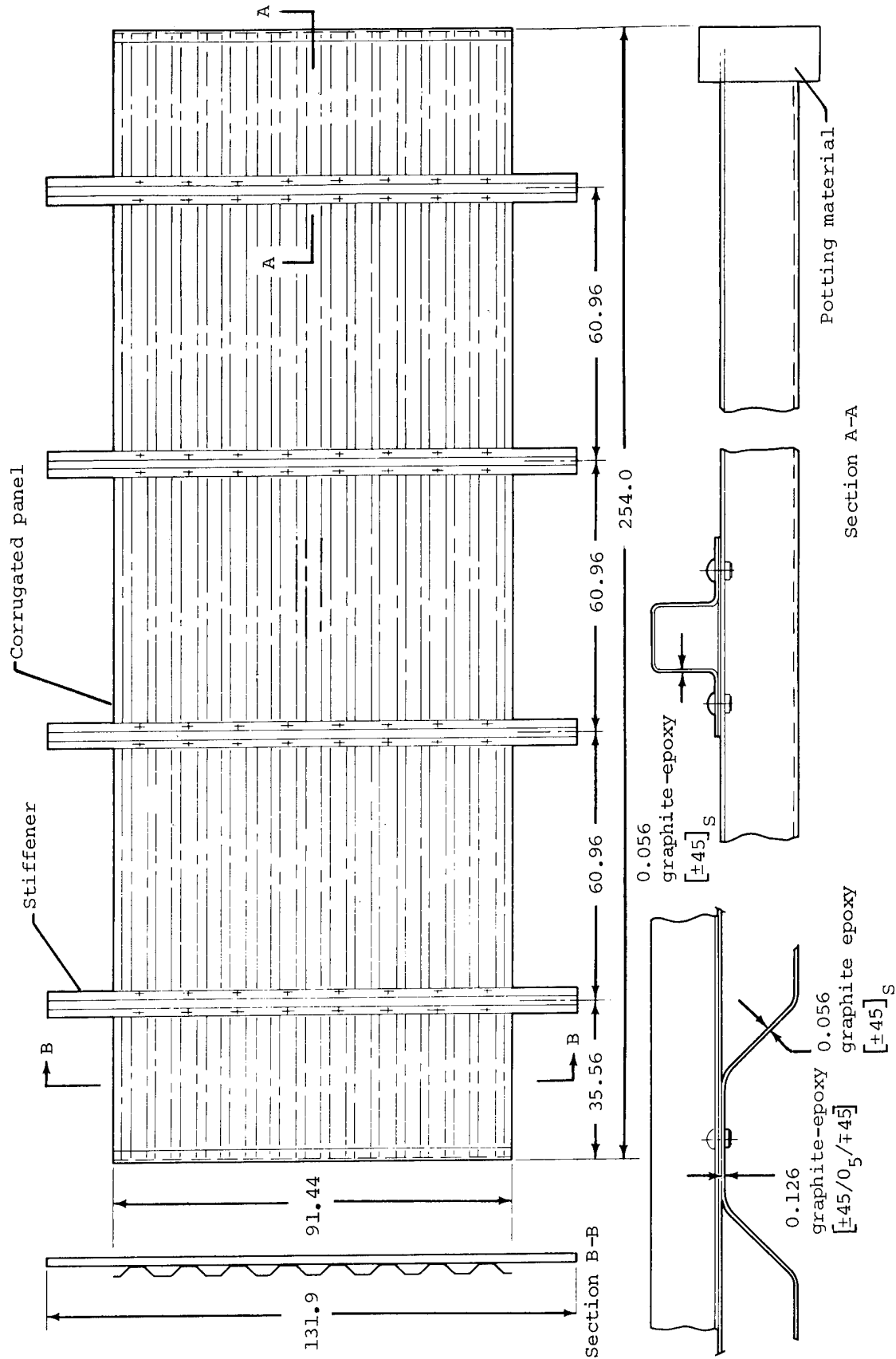
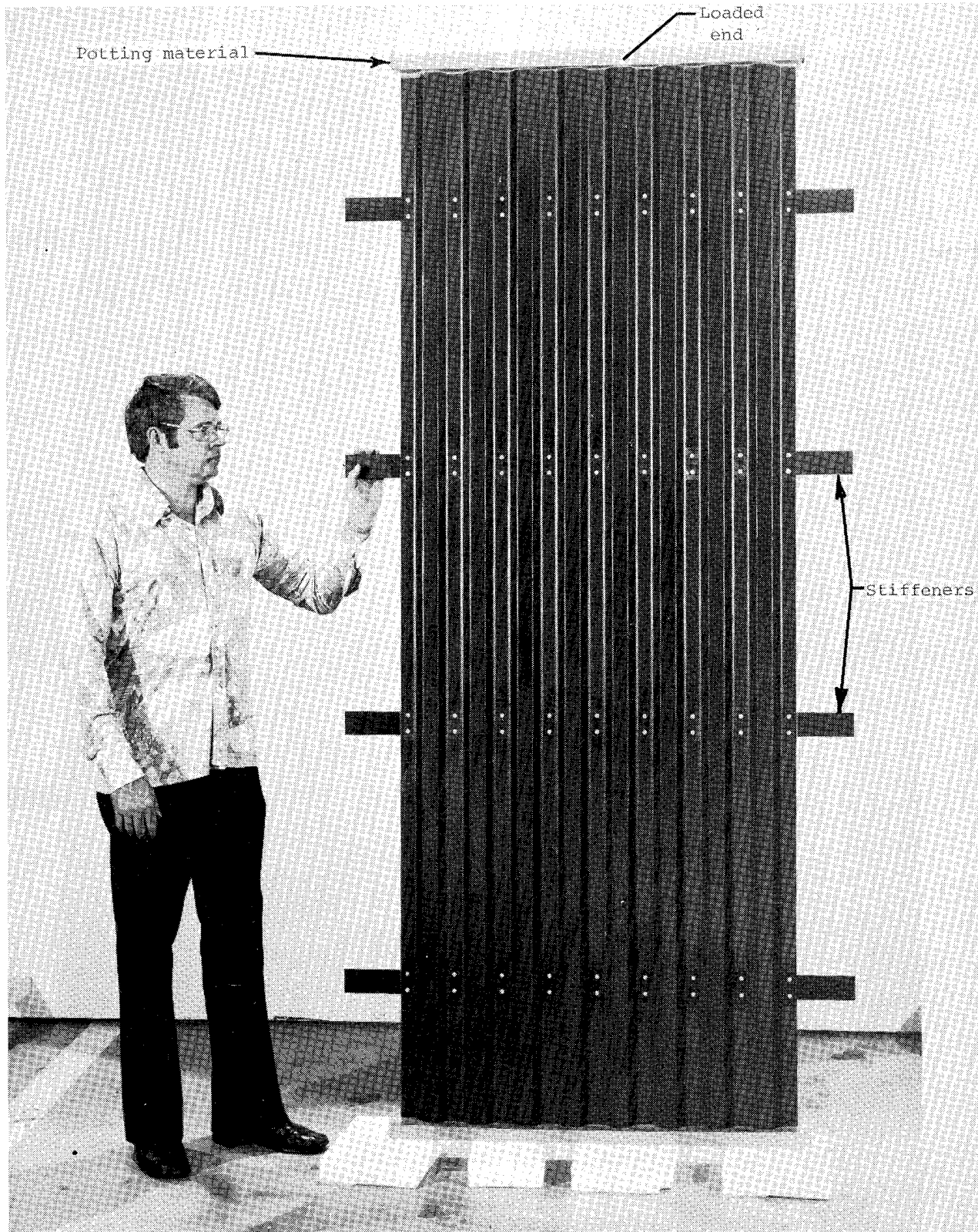

Figure 5.- Geometric details of 254.0-cm-long panels with stiffeners. Dimensions are in centimeters.



L-82-112

Figure 6.- Typical 254.0-cm-long graphite-epoxy corrugated panel with stiffeners.

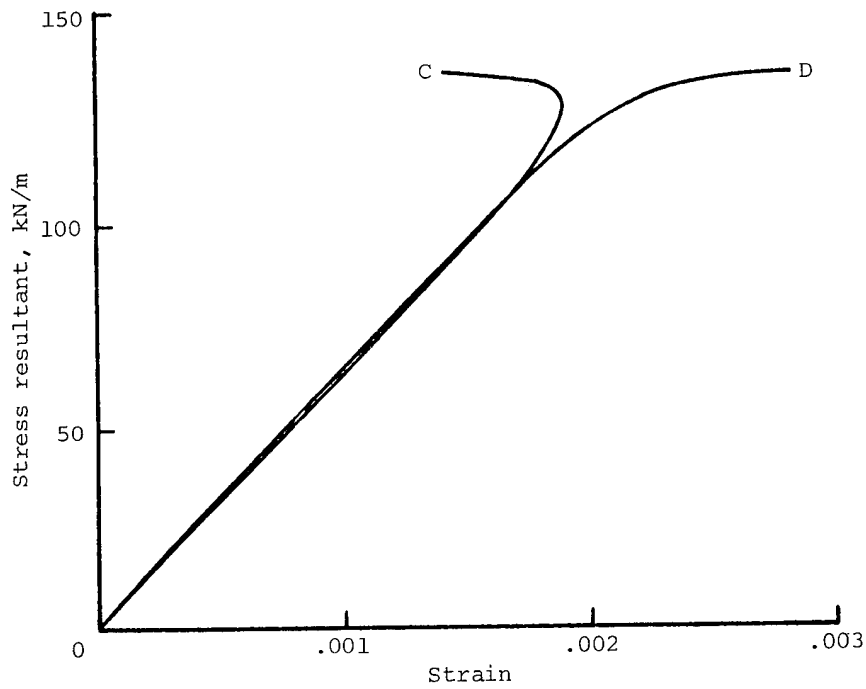
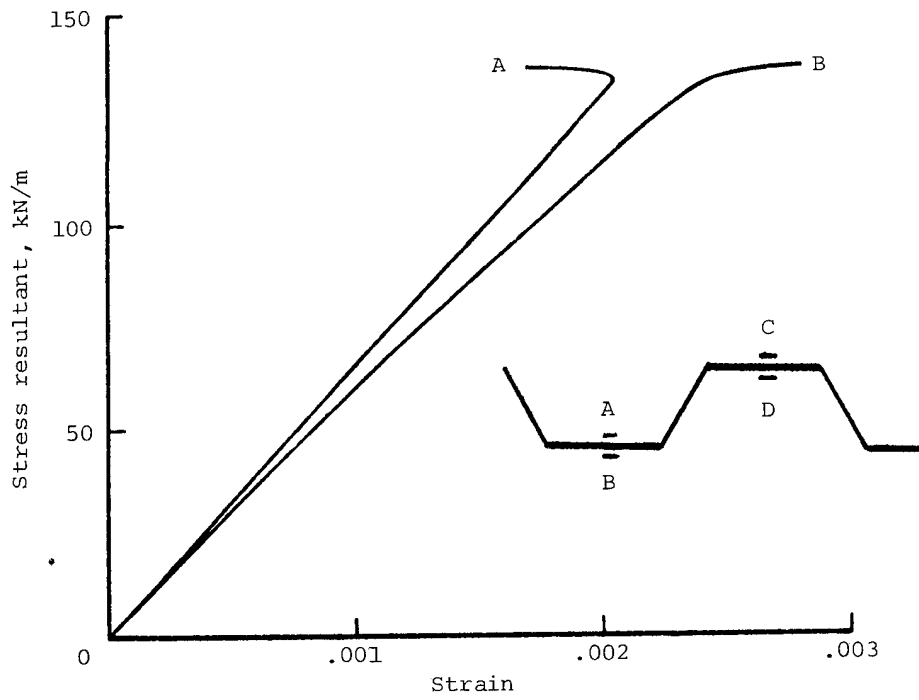

Figure 7.- Back-to-back strain-gage responses of adjacent corrugation crowns for panel 2-24.

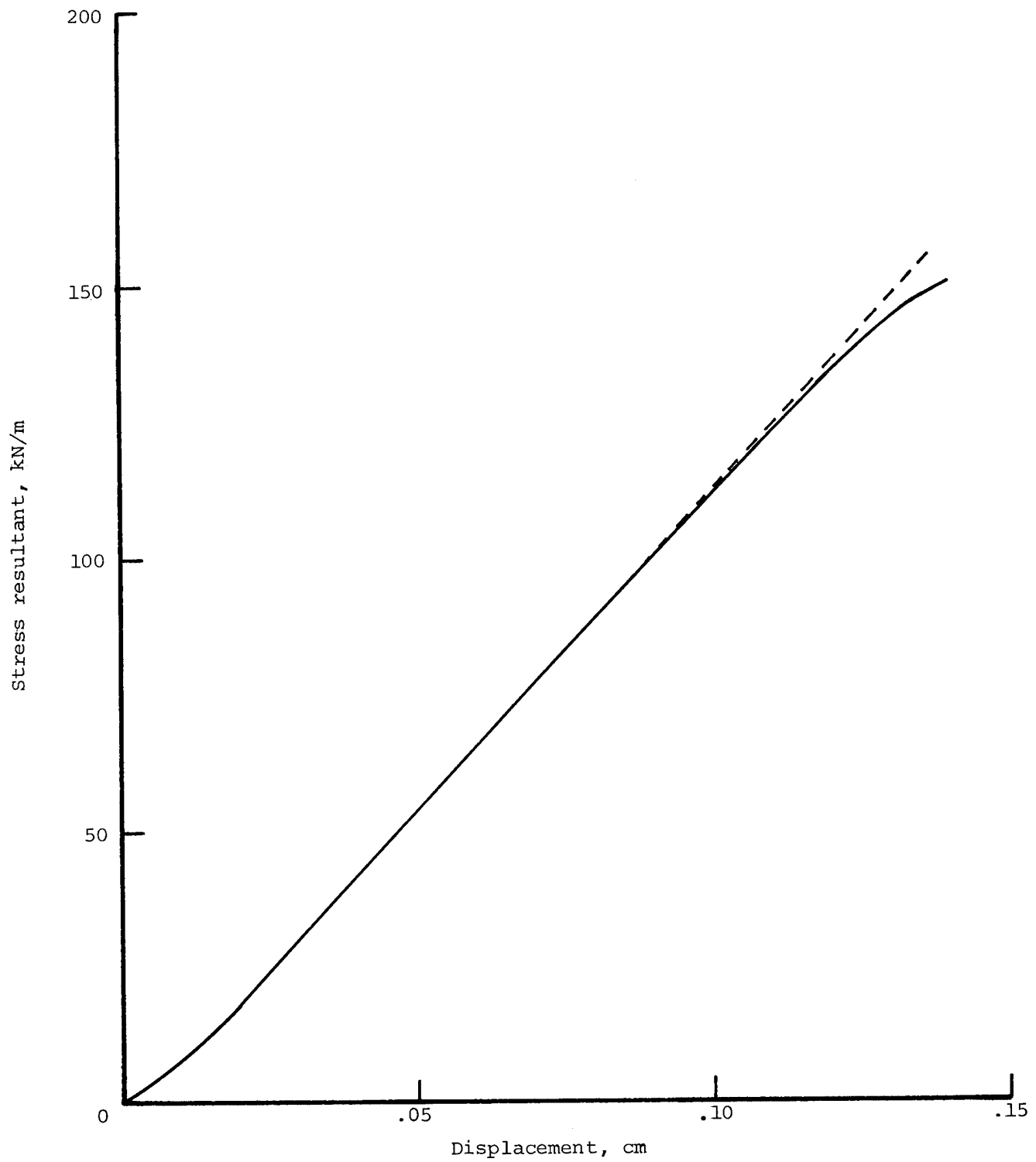
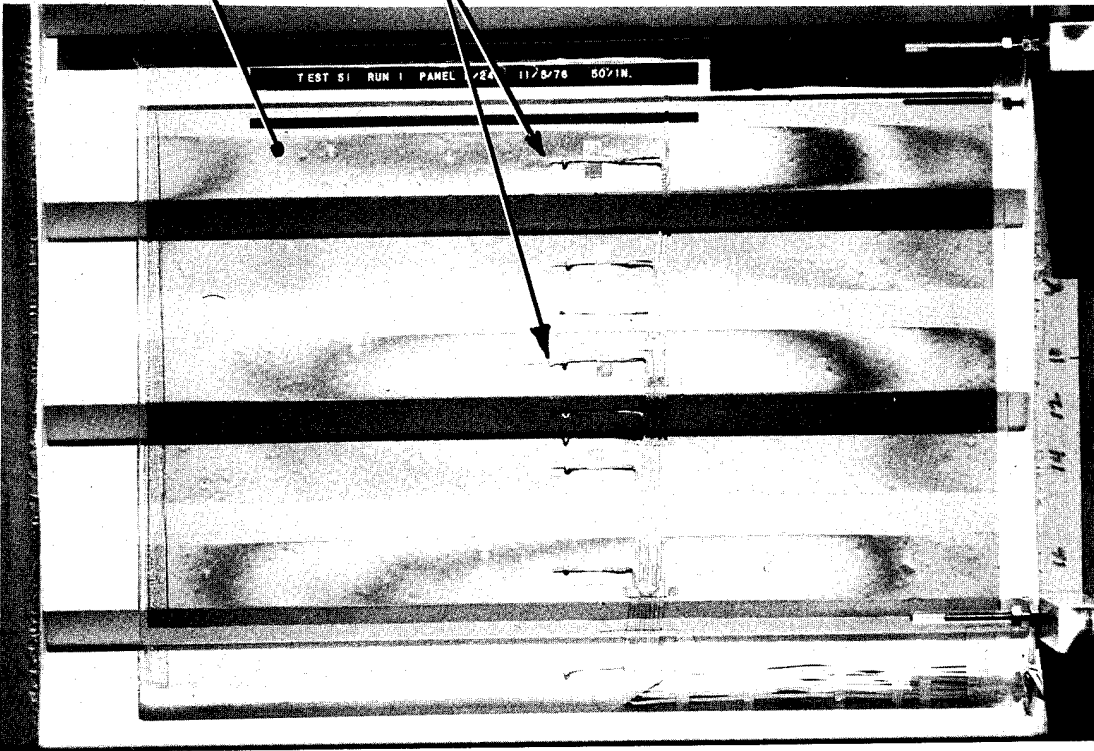
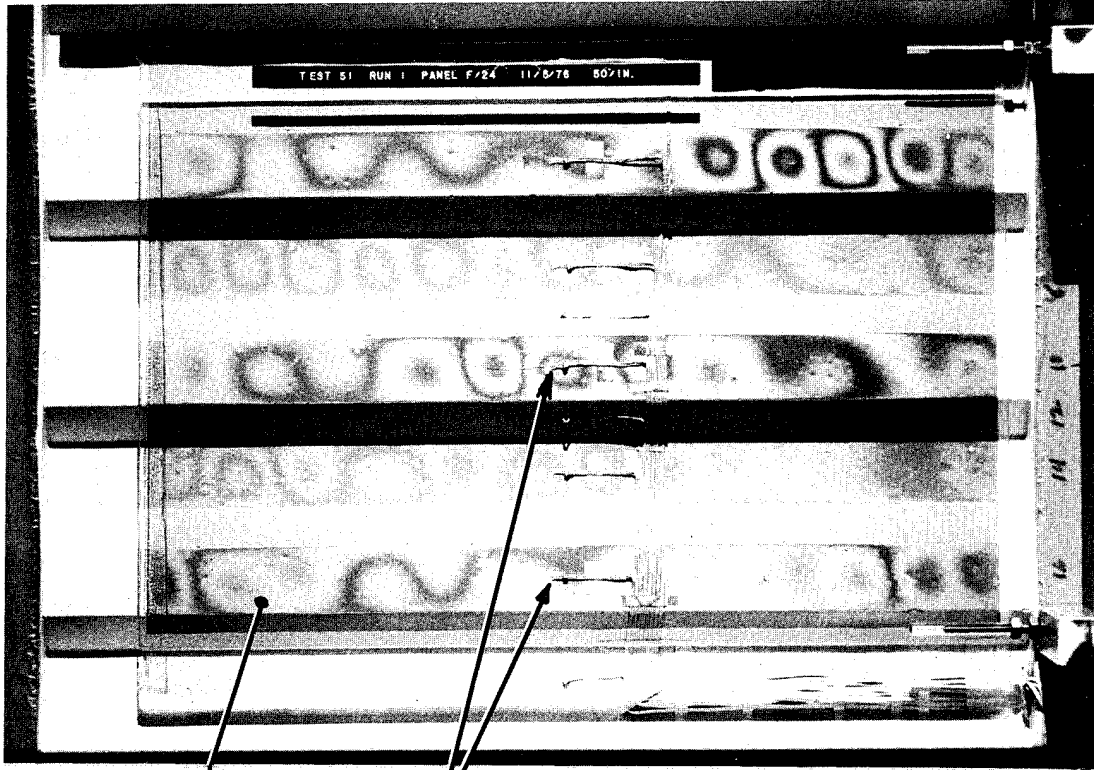

Figure 8.- End shortening as function of applied load for panel 2-24.



(a) Applied load, 118 kN/m.



(b) Applied load, 136 kN/m.

L-82-113

Figure 9.- Moiré-fringe patterns for panel 2-24 showing development of local buckle mode of crowns.

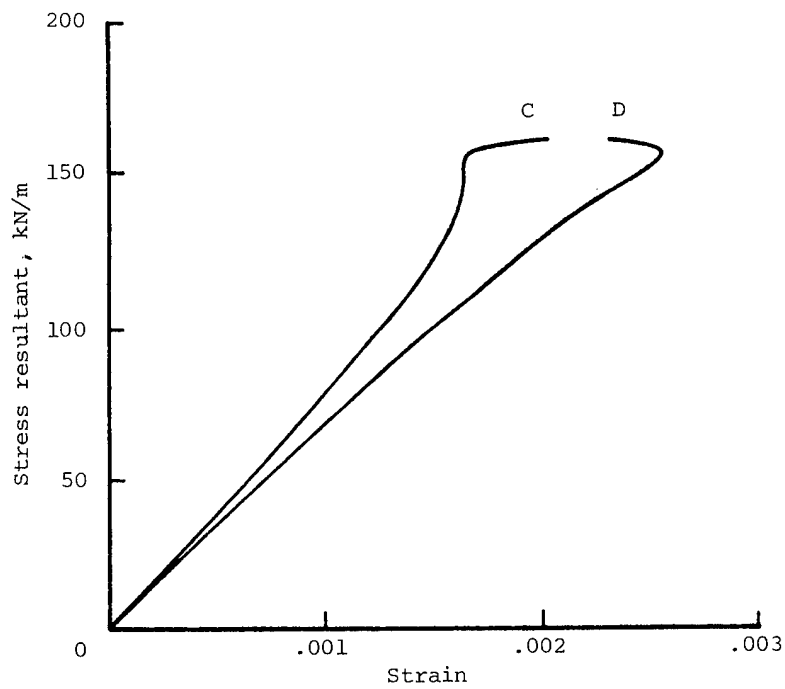
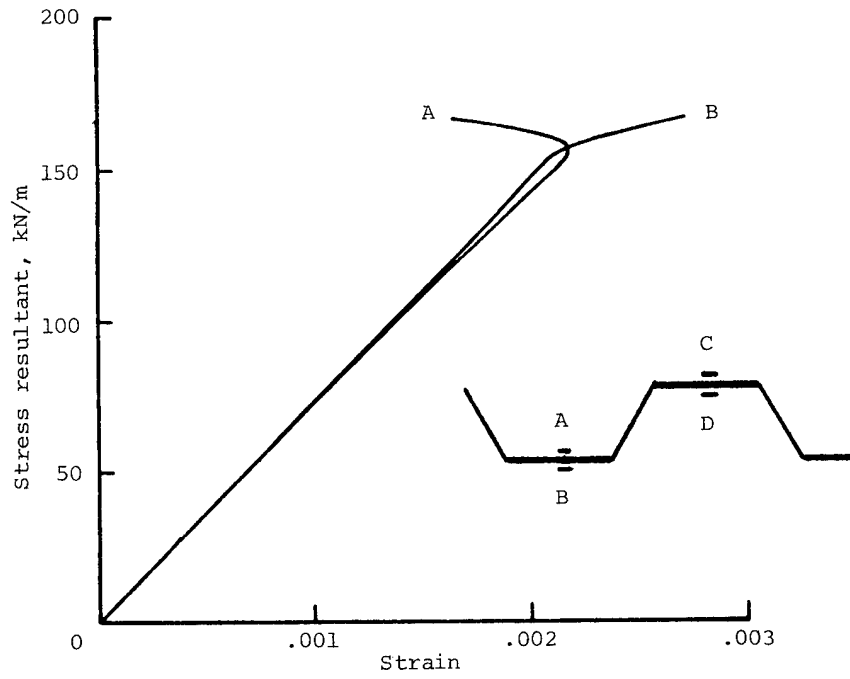

Figure 10.- Back-to-back strain-gage responses of adjacent corrugation crowns for panel 4-24.

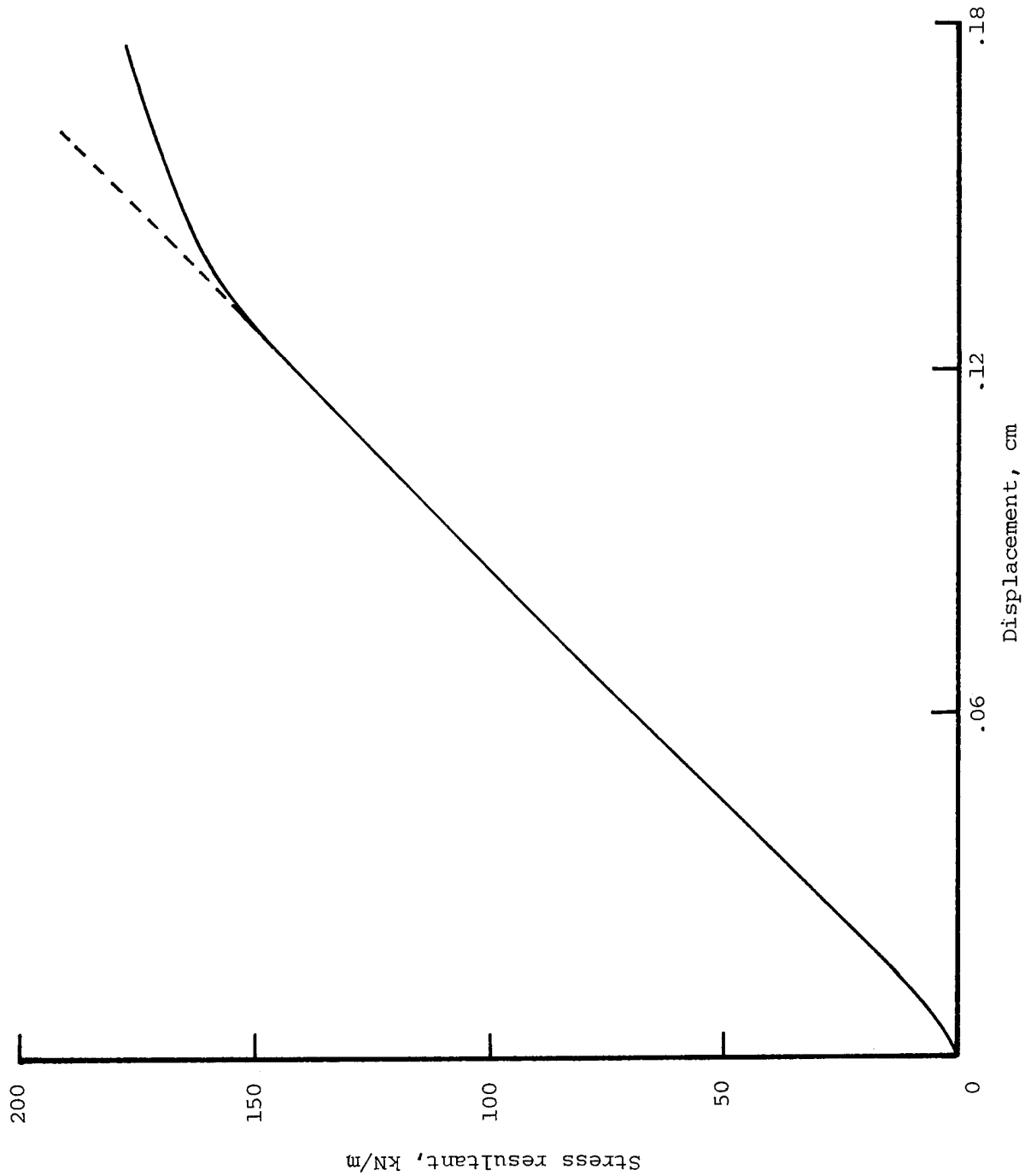
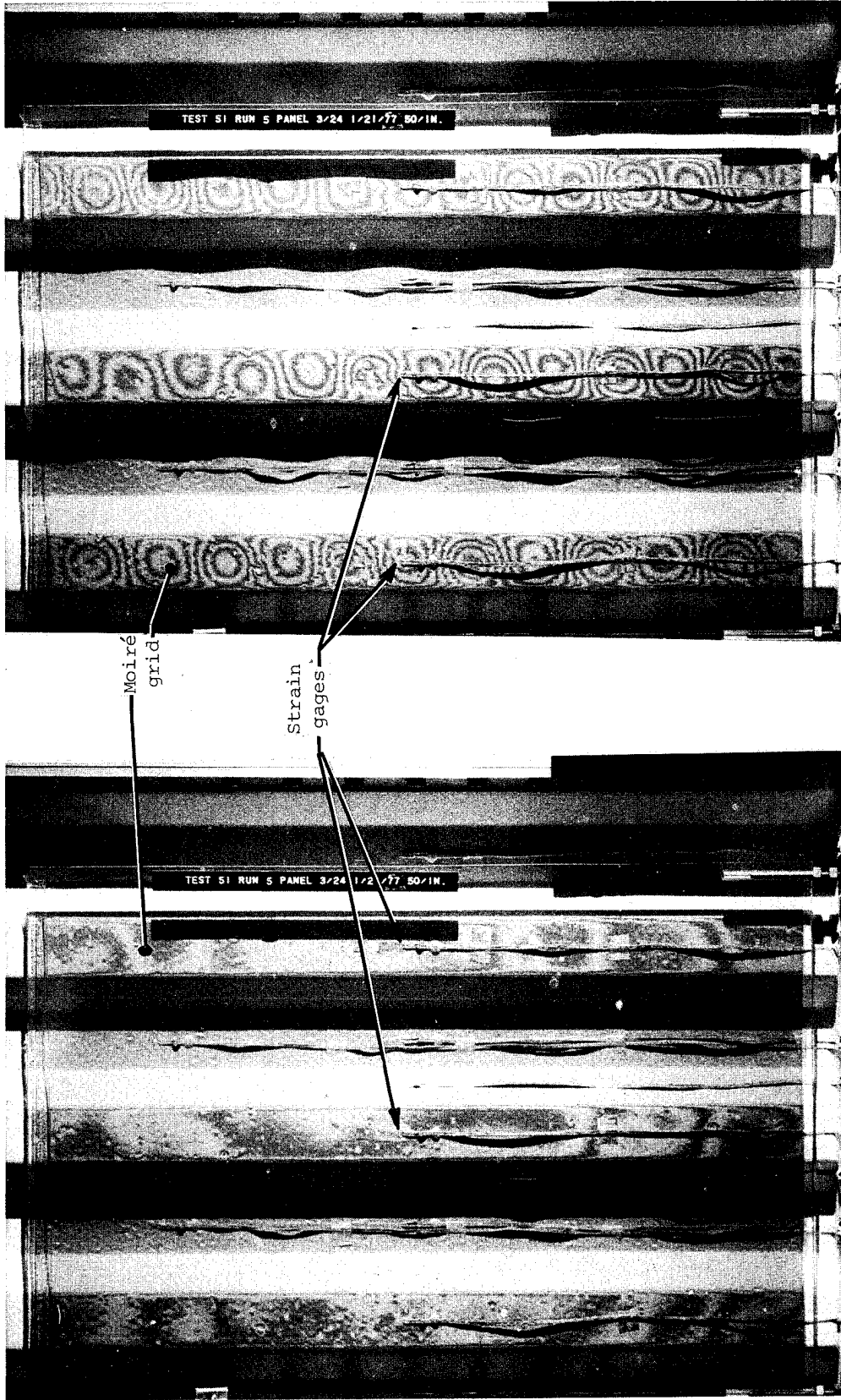

Figure 11.- End shortening as function of applied load for panel 4-24.



(a) Applied load, 146 kN/m.

(b) Applied load, 175 kN/m.

L-82-114

Figure 12.- Moiré-fringe patterns for panel 4-24 showing development of local buckle mode of crowns.

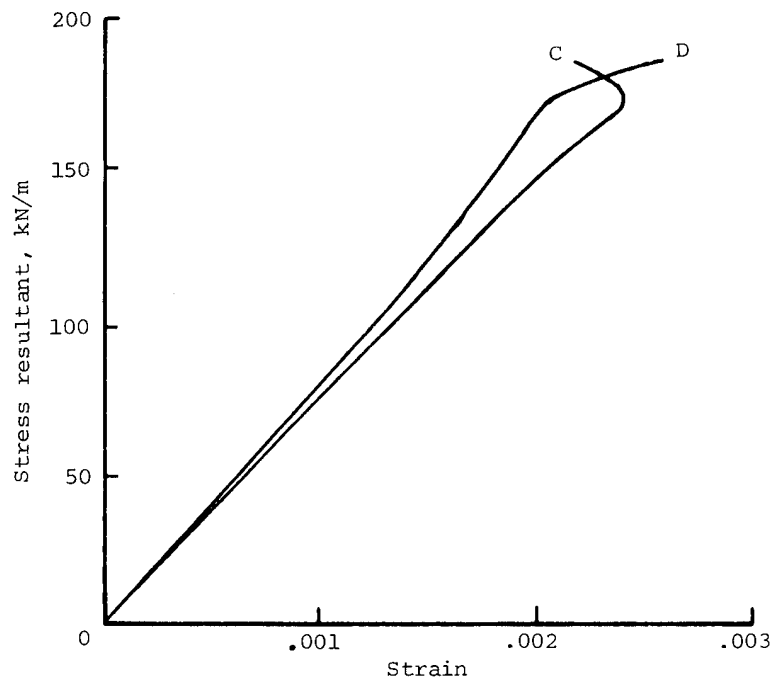
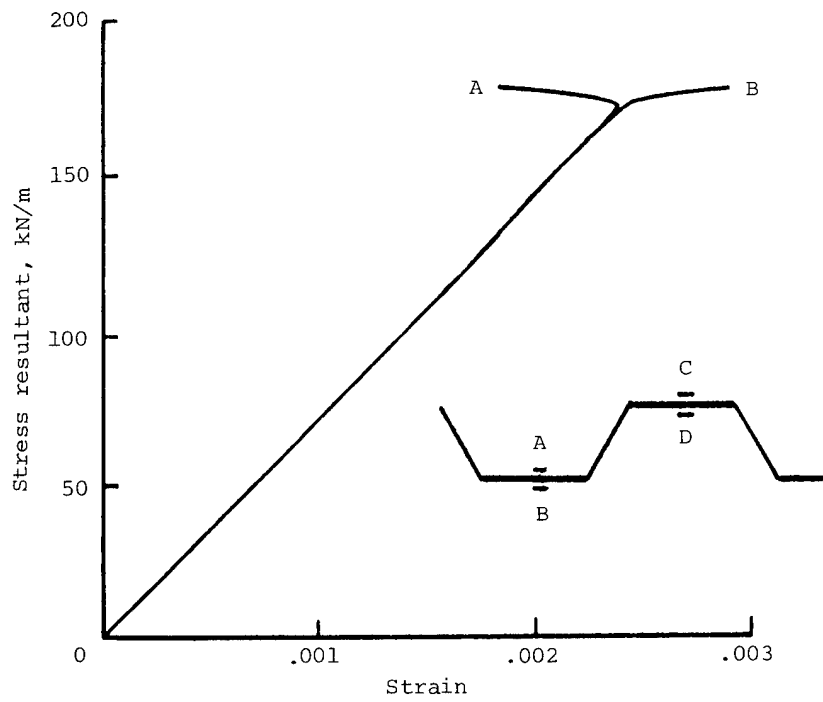

Figure 13.- Back-to-back strain-gage responses of adjacent corrugation crowns for panel 1-36.

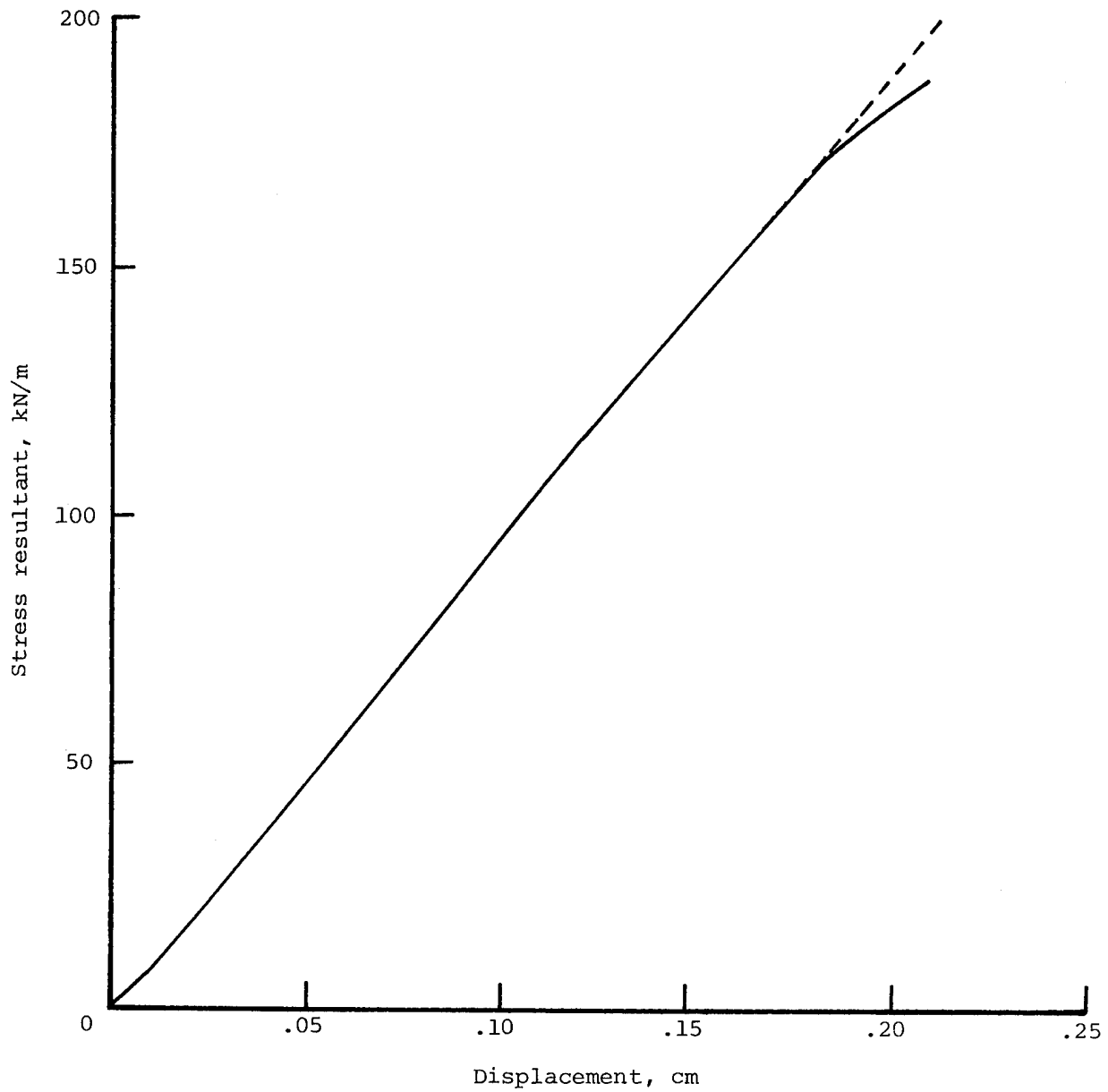

Figure 14.- End shortening as function of applied load for panel 1-36.

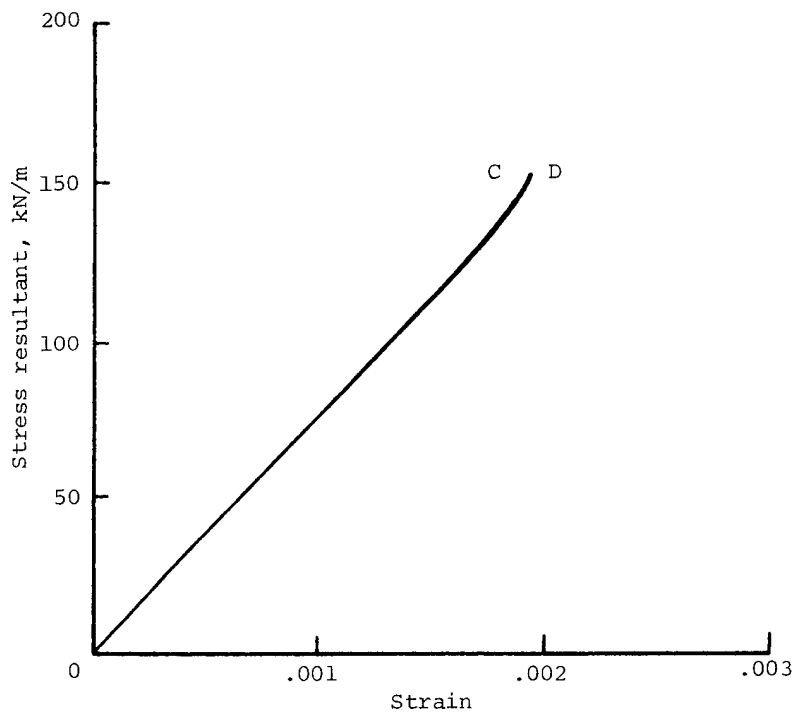
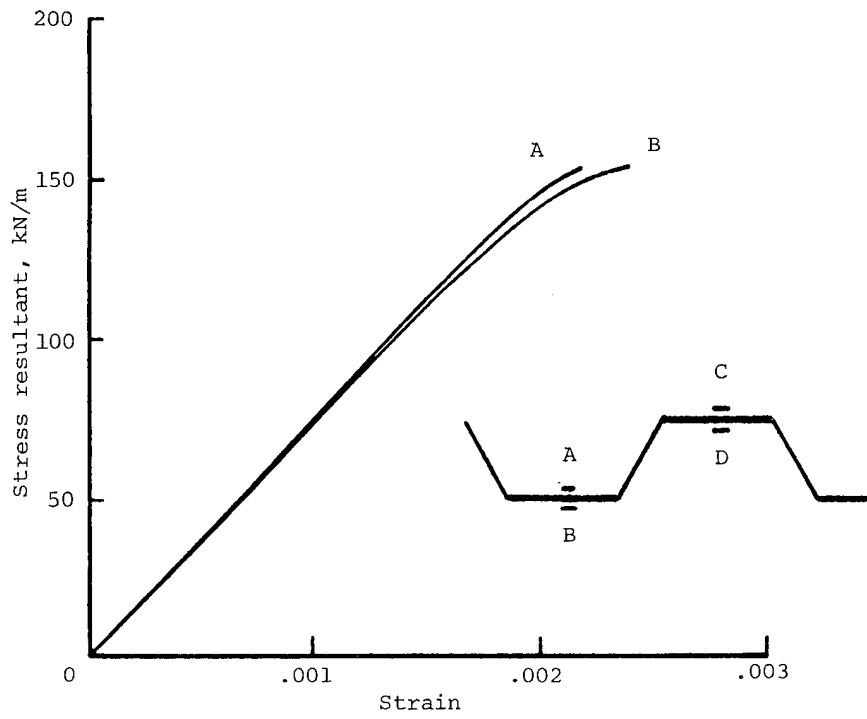

Figure 15.- Back-to-back strain-gage responses of adjacent corrugation crowns for panel 1-100.

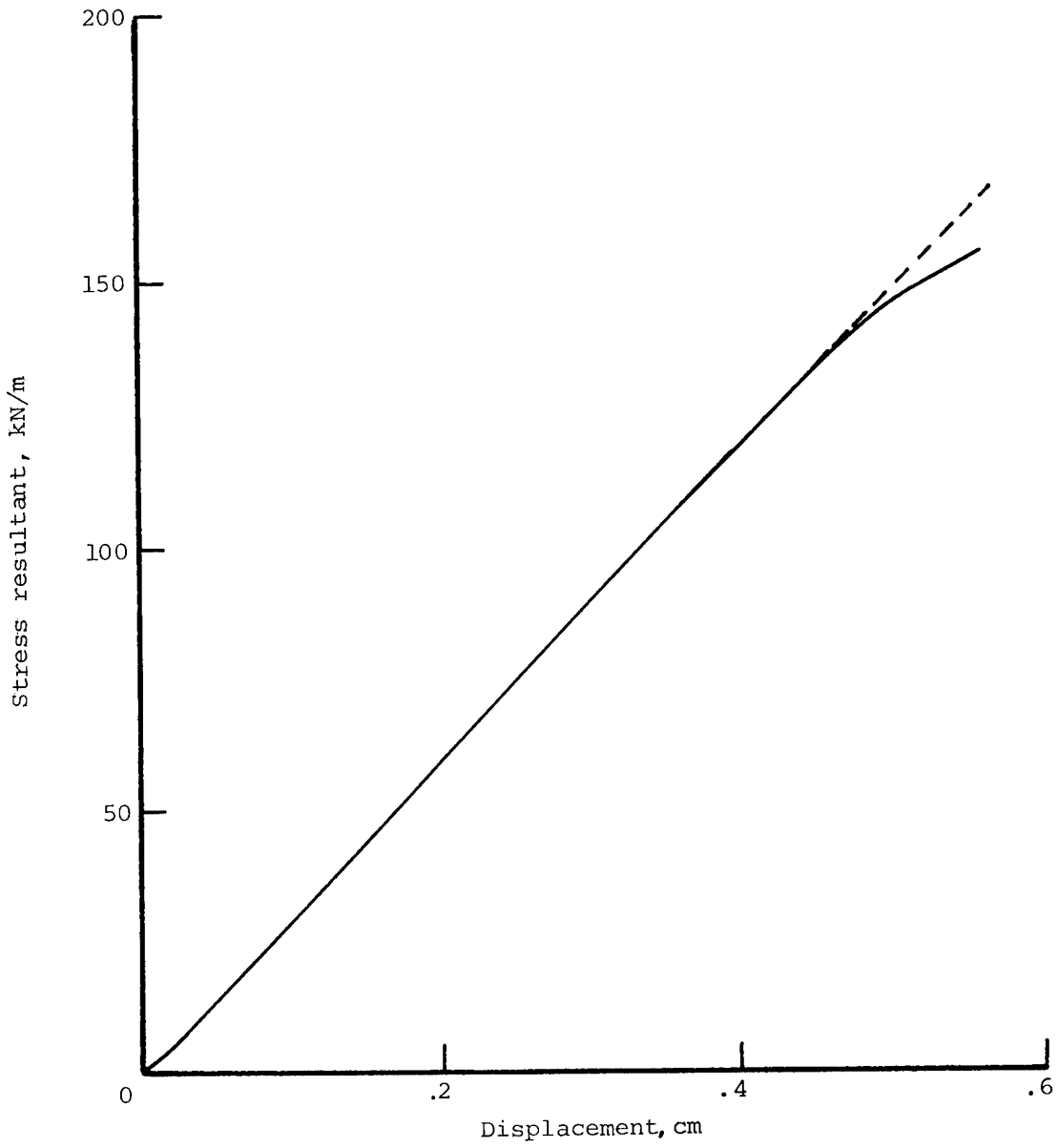

Figure 16.- End shortening as function of applied load for panel 1-100.

1. Report No. NASA TP-1981		2. Government Accession No.		3. Recipient's Catalog No.	
4. Title and Subtitle DESIGN DETAIL VERIFICATION TESTS FOR A LIGHTLY LOADED OPEN-CORRUGATION GRAPHITE-EPOXY CYLINDER				5. Report Date March 1982	
				6. Performing Organization Code 506-53-43-03	
7. Author(s) Randall C. Davis and James H. Starnes, Jr.				8. Performing Organization Report No. L-14795	
9. Performing Organization Name and Address  NASA Langley Research Center Hampton, VA 23665				10. Work Unit No.	
				11. Contract or Grant No.	
				13. Type of Report and Period Covered Technical Paper	
12. Sponsoring Agency Name and Address  National Aeronautics and Space Administration Washington, DC 20546				14. Sponsoring Agency Code	
15. Supplementary Notes					
16. Abstract  Flat corrugated graphite-epoxy panels were tested in compression to verify selected design details of a ring-stiffened cylinder that was designed to support an axial compressive load of 157.6 kN/m without buckling. Three different sizes of subcomponent panels, with the same basic corrugation geometry, were tested: (1) 60.96-cm-long by 45.72-cm-wide panels to evaluate the local buckling strength of the shell-wall design, (2) 91.44-cm-long by 45.72-cm-wide panels to evaluate a longitudinal joint and the load-introduction method, and (3) 254.0-cm-long by 91.44-cm-wide panels with four simulated-ring stiffeners to evaluate the ring-attachment method. The test results indicate that the modified shell-wall design, the longitudinal joint, the load-introduction method, and the stiffener-attachment method for the proposed cylinder have adequate strength to support the design load.					
17. Key Words (Suggested by Author(s))  Test                      Axial compression Flat panels Corrugated panels Stiffened panels Buckling test			18. Distribution Statement  Unclassified - Unlimited   Subject Category 39		
19. Security Classif. (of this report)  Unclassified		20. Security Classif. (of this page)  Unclassified		21. No. of Pages  25	22. Price  A02