

# NATIONAL AIR INTELLIGENCE CENTER

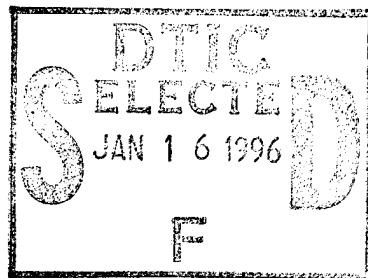

ONE TYPE OF SELF-ADAPTING AIRBORNE  
PASSIVE-PHOTOELECTRIC COUNTERMEASURE SYSTEM



**Approved for public release:  
distribution unlimited**

---

19960104 029

**HUMAN TRANSLATION**

NAIC-ID(RS)T-0382-95 21 November 1995

MICROFICHE NR: 95C000715

ONE TYPE OF SELF-ADAPTING AIRBORNE  
PASSIVE-PHOTOELECTRIC COUNTERMEASURE SYSTEM

English pages: 25

Source: Yi Zhong Zi Shi De Ji Zai Wu Yuan Guang Dian  
Dui Kang Xi Tong; pp. 15-26.

Country of origin: China

Translated by: SCITRAN

F33657-84-D-0165

Requester: NAIC/TAEC/Frank Scenna

Approved for public release: distribution unlimited.

THIS TRANSLATION IS A RENDITION OF THE ORIGINAL FOREIGN TEXT WITHOUT ANY ANALYTICAL OR EDITORIAL COMMENT STATEMENTS OR THEORIES ADVOCATED OR IMPLIED ARE THOSE OF THE SOURCE AND DO NOT NECESSARILY REFLECT THE POSITION OR OPINION OF THE NATIONAL AIR INTELLIGENCE CENTER.

PREPARED BY:

TRANSLATION SERVICES  
NATIONAL AIR INTELLIGENCE CENTER  
WPAFB, OHIO

**GRAPHICS DISCLAIMER**

All figures, graphics, tables, equations, etc. merged into this translation were extracted from the best quality copy available.

Accession For	
NTIS CRA&I	<input checked="" type="checkbox"/>
DTIC TAB	<input type="checkbox"/>
Unannounced	<input type="checkbox"/>
Justification	
By	
Distribution/	
Availability Codes	
Dist	Avail and/or Special
A-1	

## I. INTRODUCTION

Passive jamming and infrared jamming are among important component parts making up combined electronic countermeasures systems at the present time. In modern warfare, following along with the widespread application of precision guided weapons--in particular, photoelectric-infrared guidance weapons--they constitute a threat to the survival of combat aircraft which grows more severe by the day. Modern limited wars--in particular, the practical realization of the Gulf War--clearly show that most damaged or lost aircraft were all due to being attacked by infrared homing missiles. At the present time, approximately 80% of missiles opt for the use of infrared guidance. Moreover, the U.S. has already taken passive photoelectric detection equipment to act as the principal military sensors of the future. It has also been used to supply target acquisition, tracking, and positioning capabilities for stealth aircraft in order to strengthen covering capabilities. As a result, the militaries of various nations pay serious attention to passive-photoelectric countermeasure system technology equipment, which has already become one type of effective means for modern combat aircraft to carry out defense penetrations and to increase effective guarantees of airborne security.

In national wars of territorial defense, the main missions undertaken by fighters and attack planes is to carry out the aerial struggle. At the same time, it is also necessary to carry out such tactical missions as the interception of enemy bombers and the destruction of surface military targets. As a result, the primary fighter plane threat comes from aerial as well as surface missiles and fire control weapons systems. At the present time, air to air missiles and ground to air missiles are primarily divided into the three types of command guidance, infrared guidance, and radar guidance systems. Their guidance methods are just in the midst of developing into the employment of homing types and composite types to carry out guidance. As a result, when carrying out passive-photoelectric jamming stress should be given to the timeliness and directed nature of discharged foil strips/infrared missiles as well as efficiencies associated with composite jamming.

In order to adapt to the new developments in modern warfare associated with "three-dimensionality, combined tactics, and electronic warfare", as far as the simultaneous consideration of the high speed maneuverability as well as the all direction offensive and violent shock characteristics possessed by both fighters and attack planes is concerned--besides fitting airborne

radar warning equipment--it is also necessary to fit out with ingenious models of foil strip and infrared missile launchers. These are primarily used in jamming automatic tracking systems associated with enemy airborne fire control radars and air to air missile guidance systems. Secondly, they are used to jam weapons control systems associated with ground air defense systems as well as missile guidance systems.

## II. FOIL STRIP/INFRARED MISSILE JAMMING MECHANISMS

### 1. Foil Strip Jamming

When airborne passive jamming release devices scatter just the right amount of foil strips within radar resolution units on aircraft, foil strip cloud masses will produce large amounts of randomly distributed metal reflectors in space in order to form specially designated jamming corridors. If, in each radar unit, foil strip cloud reflecting surface areas are larger than reflection surface areas on aircraft by several fold, then, the electromagnetic reflection signals on fluorescent radar screens will form light belts composed of densely packed blips or give the appearance of random echoes similar to noise. This is adequate to cover--even to the point of submerging--target echoes, and, in conjunction with that, disrupting automatic radar tracking systems, thus effectively covering follow on aircraft groups, and, along with that, increasing carrier craft survival rates.

On the basis of jamming principles, it is possible to know that foil strip jamming results directly relate in a close way to the size of foil strip cloud effective reflection areas  $\sigma$ . However, during the process of scattering foil strip clouds--due to coupling and blocking effects existing between dipoles--it is then necessary to take a view to all of the effectiveness, economic characteristics, and comprehensive nature of jamming assets during rational operation. As far as releasing a number of foil strips  $N$  is concerned, it is certainly not a case of the more numerous they are, the larger  $\sigma$  then is, and the more obvious are the jamming effects. However, speaking in terms of various types of radars, the  $\sigma$  values needed are also variously different from each other. Therefore, under a presupposition of high efficiencies, it is not only necessary to guarantee single unit jamming effectiveness and multiple unit jamming effectiveness, it is also necessary to make the foil strip number  $N$  as economical as possible. At the same time, it is also necessary to grasp in a timely manner moments for introducing jamming. (The reason is that if jamming is too early, it will, on the contrary, reveal the carrier craft's intentions, providing

time for the enemy to adopt anti-jamming countermeasures. As far as jamming which is too late is concerned, it will also have difficulty arriving at the expected results and will lose the screening effects of jamming.) As a result, such questions as how to "cover assaults", accurately select optimal moments for release, how to optimize control of point launch numbers associated with each release as well as point launch time intervals, set launch numbers, missile group time intervals, and so on, then seem to be even more outstanding and urgent.

## 2. Infrared Missile Jamming

When carrier craft are tracked by infrared homing guidance heads, infrared missiles will quickly be released into their field of view. Due to infrared energy associated with carrier craft tail jet exhaust radiation and the combustion of infrared missiles both being placed in the guidance head field of view, at this time, target information is formed from the infrared energies of the two being added together. What the guidance head tracks is the center of the strength of the two infrared energies. Following along with the separation of the infrared missile and the carrier craft in space--because the infrared missile's heat radiation energy is greater than that of the /16 target aircraft--and the angles of visual field of infrared missiles at the present time being relatively small ( $\pm 2^\circ - \pm 3^\circ$ ), there is a lack of capability to accurately resolve and identify true and false targets. Therefore, the target aircraft placed in the guidance head field of vision will gradually deviate from the center of the field of view associated with the missile, finally shaking off the pursuing missile. In reality, this is one type of effective center of mass jamming means.

During the jamming processes discussed above, when missiles begin to break off following the carrier craft and turn to pursuing the infrared missile--between the decoy source and the missile--there is then a target deception distance supplied by the carrier craft. In this, adequate radiation strength and radiation sustainment periods associated with the infrared missile are extremely critical. Besides this, infrared missiles--during actual operation--have two other important scalar quantities, that is, combustion time and form of release. The requirement with regard to combustion time is simply that it is necessary to guarantee that the infrared guidance head line of sight tracking the carrier craft shows deflection effects within this period, and that is all. Form of release, by contrast, includes point launch interval  $\Delta t_1$  (related to combustion period), point launch number  $n$  (determined by the infrared radiation strength of the carrier craft), missile set interval  $\Delta t_2$  (related to the infrared tracking characteristics of the missile), and set launch number  $m$  (determined by the level of severity of threat to approach the carrier craft). As a result, the optimal jamming methods aimed at various types of infrared

missiles and different combat aircraft types (a rational selection of  $\Delta t_1$ ,  $n$ ,  $\Delta t_2$ , and  $m$  parameters) will be different in each case. Because of this, when opting for the use of infrared missile jamming, an accurate grasp of optimal release times, optimizing the selection of the best forms of release, and so on, is the same as controlling the release of foil strips. With regard to the quality of jamming results, it possesses the same key determinative role in whether or not the effectiveness and survival of carrier craft are ensured.

### III. NECESSITY OF PROGRAMMED CONTROL

#### 1. Pressing Practical Problems

As far as carrier craft being independently fitted with foil strip/infrared missile release equipment or their not being connected with airborne radar warning equipment and independent of each other are concerned, the pressing problems below are already being faced in such areas as timeliness, appropriateness, and effectiveness.

(1) Direction characteristics are bad. Release parameters (point launch number, group launch number, missile time interval) require setting on the ground before hand. Jamming types are single and fixed. Normally, they are only effective in jamming a certain type or a few types of radiation sources. It is difficult to adapt to complicated modern electromagnetic environments full of changes.

(2) Accuracy is low. The optimum times and jamming missile numbers for each iteration of release are not easy to master.

(3) Benefits are not high. Manual release carries with it a certain randomness. Jamming effects vary from person to person. With only slight carelessness, it is also possible to create blind releases.

(4) Maintenance and repair are not convenient. Opting for the use of human methods of tracking down malfunctions wastes time, expends effort, and there are a lot of mistakes. As a result, maintenance and repair quality is not high, and efficiency is very low.

#### 2. Effective Courses

Multiple functions, synthesization, and self-adjustment have already become the main development trends in electronic countermeasures systems. As a result, effective measures to overcome the problems discussed above are to take airborne radar warning systems and foil/infrared missile release devices and

organically combine them. Under the coordinated control of computers, they are synthesized into one whole, constituting a self-defense model passive-photoelectric countermeasures system in order to reach capabilities associated with real time optimization and self-adjusting releases. The former are used in order to complete in real time such signal processing missions as radar pulse interception, separation, identification, and so on. In conjunction with this, threat alarms are given. At the same time, with the help of quick computer calculations and combined control functions--on the basis of electromagnetic environment threat levels and radiation source characteristics--optimum selections are made of jamming forms, operating programmed automatic controls of foil strip/infrared passive jamming equipment to carry out accurate releases. In this way, it is not only possible to convert release processes to programmed control and optimization. It is also possible--on the basis of threat environment status--to rationally allocate jamming resources, quickly and flexibly controlling jamming equipment to make automatic adjustments to changes in the electromagnetic environment.

/17

#### IV. PRACTICAL FEASIBILITY OF PROGRAMMED CONTROL CONNECTIONS

In order to constitute self-defense models of passive-photoelectric countermeasure systems to realize the objective of comprehensive and effective jamming, it is necessary to install programmed control connections between radar warning systems and foil strip/infrared missile release devices. The connection relationships associated with composite self-defense type jamming systems are as shown in Fig.1.

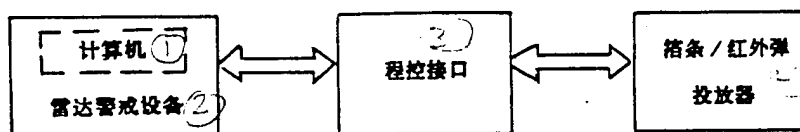

Fig.1 Composite Connections Associated with Self-Defense Type Passive-Photoelectric Countermeasure Systems

Key: (1) Computer (2) Radar Warning Equipment (3) Programmed Control Connections (4) Foil Strip/Infrared Missile Release Devices

From Fig.1, it is possible to see that the entire system is coordinated under the real time control of computers and operates in parallel. Moreover, computers then opt for the use of self-adaptation algorithms to carry out system monitoring and control.

Foil strip/infrared missile release devices are capable of selecting for use two types of operating modes--automatic release and manual/semiautomatic release. During automatic release--in accordance with electromagnetic information received by radar warning equipment--there is automatic selection of the optimum release form, carrying out jamming against the most severe threat source among them or in accordance with threat levels in high to low order and executing jamming against various radiation sources in sequence. This is one type of fully automatic operating method. The foil strip/infrared missile release sequence is as shown in Fig.2.

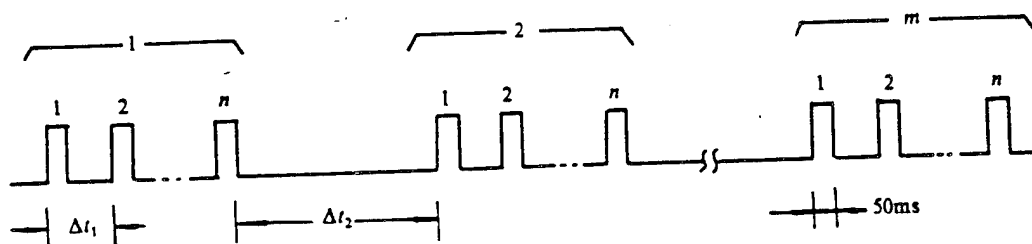

Fig.2 Foil Strip/Infrared Missile Release Sequence

In Fig.2, set launch numbers  $m$  associated with each iteration of release, point launch numbers  $n$ , as well as time period intervals  $\Delta t_1$  and  $\Delta t_2$  all are controlled by computer programs. The release parameters ( $m$ ,  $n$ ,  $\Delta t_1$ , and  $\Delta t_2$ ) corresponding to each threat source all need to go through empirical measurement. After that, the best are chosen, selecting optimum composite code to fill in the release data tables within the main memory storage devices, thereby guaranteeing the most ideal jamming effects against various enemy radiation sources. During manual/semiautomatic release, by threat status displayed on pilot observation and warning equipment screens--relying on his or her combat experience--selection is made of the optimum course and jamming moment. The "release" button is pressed aiming at the most severe threat source, carrying out effective jamming. At this time, foil strip/infrared missile jamming equipment then carries out accurate release under the control of computer programs. The set

launch number m, the point launch number n, the time intervals delta t1 and delta t2 associated with each release are still driven by optimum combinations of code characters from release data tables within the main memory storage devices.

No matter which type of operating mode is opted for, once foil strip/infrared missile release is completed, "CH EMT" (foil strip air) or "FL EMT" (infrared missile air) will be automatically displayed on the optical screens of radar warning equipment.

Making a comprehensive comparison between self-defense model passive-photoelectric countermeasure systems and other airborne EW equipment, they have the advantages below:

(1) High Degree of Cover

The systems in question bring into play the efficiencies of passive monitoring--passive jamming. In and of themselves, they do not emit electromagnetic waves. As a result, they are very well concealed, reliable, and reduce the revealing signatures of carrying aircraft. Moreover, they will not meet with attacks from antiradiation missiles. This will clearly increase the survival rate of carrier craft.

(2) Precise Identification Characteristics

In systems, such processing tasks as the ESM signal acquisition, measurement, as well as selection, and so on, are completed by radar warning equipment. In conjunction, use is made of built in 16 bit minicomputers to identify targets and their delivery platforms on the basis of signal frequencies, pulse widths, repetition frequencies, modulation characteristics, as well as antenna scan forms. As a result, they possess relatively strong and precise signal identification capabilities.

(3) Broad Adaptability

In modern warfare, various types of advanced weapons systems all make use of electromagnetic information to carry out guidance and control. The frequency domain coverage ranges of the systems in question are comparatively wide (0.7-1.4GHz and 2-18 GHz). Moreover, opting for the use of wide open type all direction receivers, sensitivities can reach -52dBm, thereby enabling the interception of various types of radar targets such as detection, warning, acquisition, tracking, guidance, and so on, at long range. In conjunction with this, it is possible to carry out effective passive-photoelectric jamming.

(4) Strain Sensitivity

In order to facilitate fast replacement and repair, release

programs opt for the use of table driven types of structures. Release command pulses sent by computers depend entirely on code characters in release data tables. When electromagnetic environments give rise to changes, it is only necessary to insert or delete the corresponding code characters. Moreover, there is no need for revision programs, that is, it is possible to realize jamming efficiency against new threat sources, thereby causing release programs to possess even greater sensitivity and adaptation capabilities.

#### (5) Reliable Dual Forms

The intervention of program control connections certainly does not influence the operating functions of warning equipment or release devices. When methods are automatic, it is possible to make the structure into a closed ring type combined jamming system. Once connection circuits show the appearance of malfunctions, then, cut off is automatically carried out back to the basic control form. The two types of equipment still operate independently and in parallel on their own in accordance with original operating processes.

#### (6) Malfunction Autochecking Functions

Making use of reserve inspection measurement connections associated with radar warning equipment and computer malfunction diagnosis programs, it is possible to carry autochecking test measurements on composite systems including in them foil strip/infrared missile release devices. It is possible to automatically display the form and location of malfunctions. Autocheck periods are only a few seconds. Thus, the maintainability and repairability of systems is very, very greatly increased.

#### (7) Small Volumes, Light Weights, High Efficiencies

Due to the separate cover and passiveness characteristics, the heavy load of transmission systems is, therefore, gotten rid of. In comparison to other EW systems, they are really small in volume and light weight. Also, because of the possession of a combination of all direction air space coverage, wide band frequency ranges, fast response times, precise identification characteristics, and multiple types of functional uses, their operating efficiencies are, therefore, comparatively high.

## V. PROGRAMMED CONTROL CONNECTION OPERATING PRINCIPLES

### 1. Hardware Section

#### (1) Release Status Check Measurement Circuits

Foil strip/infrared missile release status check measurement circuits are as shown in Fig.3. In Fig.3, see Table 1 for control logic relationships associated with digital control selection devices. /19

Table 1 Digital Control Selection Device (54150) Control Logic

表 1 数控选择器(54150)控制逻辑

① 计算机检测指令	② 设备选择线						③ 选 通	④ 输出端
	$\overline{DS0}$	$\overline{DS1}$	$\overline{DS2(D)}$	$\overline{DS3(C)}$	$\overline{DS4(B)}$	$\overline{DS5(A)}$		$\overline{SLEDONE}$
SKPDN 0~SKPDN 57	x	x	x	x	x	x	1	⑤ 不工作
SKPDN 60	0	0	1	1	1	1	0	Q=D15
SKPDN 61	0	0	1	1	1	0	0	Q=D14
SKPDN 62	0	0	1	1	0	1	0	Q=D13

注: ①0-低电平, 1-高电平; ② x = 0 或 1。

Key: (1) Computer Test Measurement Commands (2) Equipment Selection Lines (3) Selection Channel (4) Output Terminal (5) Nonoperational (6) Note: ((1)) 0-Low Electric Level, 1-High Electric Level; ((2)) x = 0 or 1.

Digital control selection devices only operate when "selection channel" terminal (9) is a low electric level (0). Four bit binary code is capable of selecting any one terminal signal among the 16 output terminals DO-D15 and sending it out through output terminal Q(10). In the Fig., DO-D12 output terminals are also used for other things.

From Fig.3 and Table 1, it is possible to know that, when computers execute commands SKPDNO-SKPDN57, both  $\overline{DS0}$  and  $\overline{DS1}$  are not able to simultaneously be 0. As a result, the "selection channel" is always 1. Selection devices do not operate. When computers carry out the command SKPDN60,  $\overline{DS0} \sim \overline{DS5} = 001111$ . The "selection channel" terminal is 0. ABCD = 11112(1510). Then, Q = D15. Then, in accordance with the status of the "release" key, signals will then go through  $\overline{SLEDONE}$  ("complete" selection). Main control lines send them to computers, and test measurements are carried out. On the basis of the highs and lows of Q terminal (D15) signal electric levels, computers are then capable of directly determining distinguishing whether or not the "release" button has already been pushed. In the same way--going through the execution of commands SKPDN61 and SKPDN62--computers are also capable of determining whether or not foil strip/infrared missile release has been completed.

During clock interrupted programs, execution of the three decision skip commands discussed above is carried out at fixed intervals. Computers are then capable of completing cyclic test measurements with regard to release device control push buttons as well as operating configurations.

## (2) Release Command Sending Circuits

Foil Strip/infrared missile release command sending circuits are as shown in Fig.4. In Fig.4, logic control relationships associated with 8 bit programmable address lock storage devices are seen in Table 2.

8 bit programmable address lock storage devices only operate when EN "selection channel" terminal (14) is a low electric level (0). Three bit binary code composing address line A2ALAO is capable of selecting output terminal D electric level signals and sending them out by any one terminal among the 8 output terminals Q0-Q7. Among these, output terminals Q0-Q5 remain temporarily empty.

Table 2 8 Bit Programmable Address Lock Storage Device (54LS259)  
Control Logic

计算机指令	设备选择线						E N	输出端	
	$\overline{DS0}$	$\overline{DS1}$	$\overline{DS2}(A2)$	$\overline{DS3}(A1)$	$\overline{DS4}(A0)$	$\overline{DS5}(D)$		Q6	Q7
NIOC 0~NIOC 57	x	x	x	x	x	x	1	不工作	
NIOC 60	0	0	1	1	1	1	0	x	1
NIOC 61	0	0	1	1	1	0	0	x	0
NIOC 62	0	0	1	1	0	1	0	1	x
NIOC 63	0	0	1	1	0	1	0	0	x

Key: (1) Computer Command (2) Equipment Selection Line (3) Output Terminal (4) Nonoperational



/20

Fig.3 Foil Strip/Infrared Missile Release Status Test  
Measurement Circuits

Key: (1) Release Device (2) Program Control Connection (3)  
"Release" Button (4) Infrared Missile Empty (5) Foil Strip  
Empty (6) Push Down (7) Digital Control Selection Device (8)  
Selection Channel (9) Radar Warning Equipment (10)  
Microcomputer

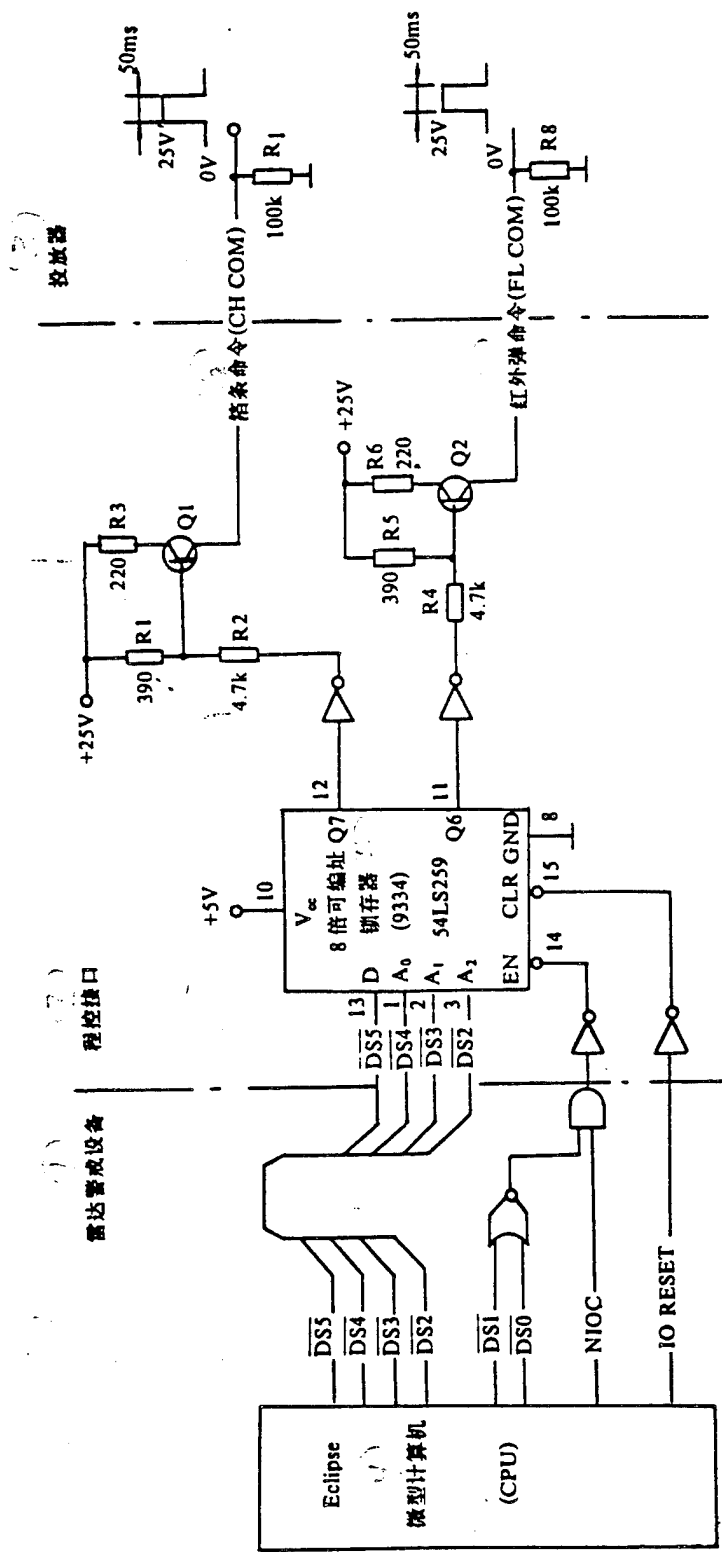

Fig.4 Foil Strip/Infrared Missile Release Command Sending  
Circuits (1) Radar Warning Equipment (2) Program Control  
Connection (3) Release Device (4) Microcomputer (5) 8 Bit  
(illegible) Programmable Address Lock Storage Device (6) Foil  
Strip Command (7) Infrared Missile Command

From Fig.4 and Table 2, it is possible to know that, when computers execute commands NIOCO-NIOC57, 1 and 2 are not capable of both being 0 at the same time. As a result, EN terminal is always 1. Lock storage devices do not operate. After computers send the zeroing pulse IO RESEET, lock storage device terminals Q0-Q7 are all zero. The C electrode of transistor Q1 is a low electric level. When computers execute command NIOC50, 1 - 3 = 0011112. CPU sends NIOC pulse. EN terminal is 0. Lock storage devices operate. A2A1A0 = 1112(710). Then, with Q7 selected, Q7 = D = 1. The C electrode of transistor Q1 switches from a low electric level to a high electric level. After this, lock storage device Q7 terminal and the C electrode of Q1 maintain high electric levels right through. When 50ms of computers going through clock interrupted program test measurements has already been reached, there is immediate execution of command NIOC61. At this time,

1 - 3 = 00111303. Q7 is still selected. Q7 = D = 0. The C electrode of transistor Q1 then switches from a high electric level to a low electric level and maintains it. At this point, a 50ms wide foil strip release command pulse is then sent out. In the same way, computers go through the execution of the two commands NIOC62 and NIOC63 one after the other. Going through lock storage device Q6 terminal, a 50ms wide infrared missile release command pulse is then produced at the C electrode of transistor Q2. The two release command pulses both pass through directly driving release devices, employing electric contact ignition methods and setting off the launch load.

## 2. Software Section

### (1) Release Code Characters

Foil strip/infrared missile release control code characters can be designed into the form below:

0	1	2	3	4	5	6	7	8	9	10	11	12	13	14	15
$\Delta t_1$				$n$			$R$	$\Delta t_2$				$m$			

Table 3 Functions of Various Character Sections in Release Code Characters

字段	字段长(位)	最小单位	范围	注 解
$\Delta t_1$	4	50ms	100~800ms	$\Delta t_1 = 50 + T \times 50(\text{ms})$
$n$	3	1	1~7	每组中的点射数
$R$	1			弹组随机间隔标志
$\Delta t_2$	4	1s	1~15s	弹组之间的时间间隔
$m$	4	1	1~15	组数(齐射数)
优先级				各编码字在数据表中的编排顺序即代表由高至低的优先级序列

Key: (1) Character Section (2) Character Section Length (Bits) (3) Minimum Unit (4) Scope (5) Remarks (6) Priority Level (7) Point Launch Number in Each Set (8) Missile Set Random Time Interval Index (9) Time Interval Between Missile Sets (10) Set Number (Complete Launch Number) (11) The arrangement sequence of various code characters in data tables stands for priority level order from high to low.

In Table 3, T is the base ten numerical value formed by the character section delta t1. Bit 7 R=0 stands for the time interval between various missile sets being a constant, all equal to delta t2. If R=1, then it stands for the time interval between various missile sets being a random variable, as shown in Fig.5. In this, A, B, C, and D time periods will be determined

by a different specialized set interval character, and m, n, and delta t1 parameters are then maintained invariable. /23

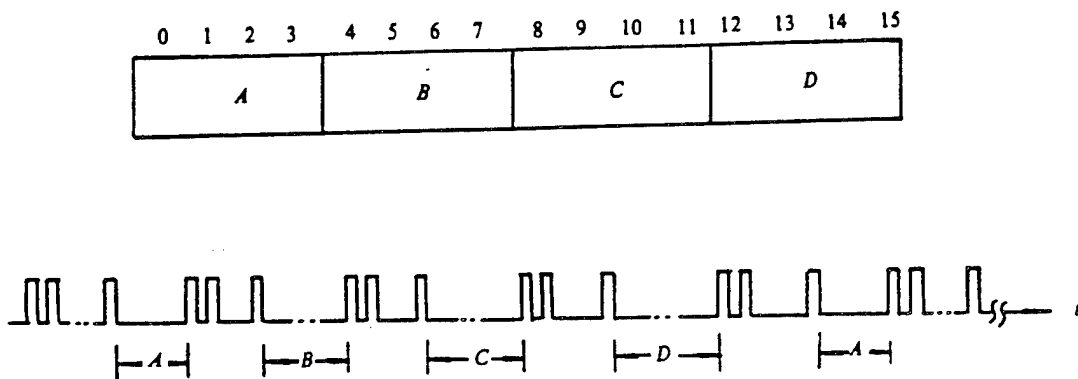

Fig.5 Set Interval Characters and Release Sequences When R = 1

(2) Release Programs

Foil strip/infrared missile release programs are capable of carrying out designs in accordance with the flow charts below (Fig.6 and Fig.7).

Programs first of all do check measurements on whether or not "mode" keys are pushed down. In a next step, they determine whether to opt for the use of fully automatic modes or semiautomatic modes to carry out release. With automatic mode, optimum jamming release moments must be automatically controlled by computer on the basis of radiation source properties threat levels. When semiautomatic, jamming release moments depend completely on the pilot's mastery of controlling the "release" key.

When the threat source is fire control radar, guidance radar, or command telemetry placed in initial phase guidance, from release data tables, it is only possible to select codes controlling foil strip releases. It also clearly shows that, at this time, there is no need to release infrared missiles. When threat sources are infrared homing missiles (going through identification of tracking radar systems, and, in conjunction with that, inferring connected weapons) and systems or command telemetry are placed in intermediate and terminal phase infrared homing guidance, from release data tables, it is not only possible to select foil strips. At the same time, it is also possible to select code characters to control infrared missile release. After that, again going through release command transmission circuits, in accordance with respective optimum code character data, programmed control command pulses are sent to release foil strips and infrared missiles. As far as the release period is concerned, "CH" (foil strips) or "EL" (infrared missile) will scintillate as displays on radar warning equipment screens. With help from this type of complete screen display of such things as threat and release information, and so on, it is possible to supply pilots with real time monitoring of jamming release effects associated with foil strips/infrared missiles. At certain critical junctures, when jamming effects are not good enough, it is also possible to assist the evasion tactics of maneuvering aircraft.

## VI. CONCLUDING REMARKS

Based on compatible control characteristics between radar warning equipment and foil strips/infrared missile release devices as well as comprehensive results proving in a number of areas such as domestic electronic component quality indices at the present time as well as airborne equipping measures (programmed control connections weight 0.32kg, dimensions 4x9x10 cm<sup>3</sup>), and so on--to include experimental measurements carried out on programmed control connection prototypes already completely developed--it is clearly shown that the implementation of system connections between warning equipment and release devices through programmed control connections makes them combine into self-defense model passive-photoelectric countermeasure systems the real feasibility of which they already fully possess. Moreover, computer software programming possesses the characteristics of flexibility, changeability, and expandability. Making use of the real time recording functions associated with warning equipment--besides being able to record the signature parameters associated with various carrier radiation sources as well as display on screens processes of dynamic change--it is also possible at the

same time to record foil strip/infrared missile release jamming results. Thus, for the sake of accurate determinations and empirical verification of the efficiencies of composite jamming, a practical basis is provided to facilitate the further optimization and perfecting of release programs. Going through this type of method, electronic warfare operating software is not only made to achieve optimum adaptations. It is, moreover, also capable of countering changes in the electromagnetic environment well. On this foundation, it is also possible to expand internal storage capacities, adding supplements of corresponding "pilot expert system" and "decision making analysis and knowledge base" software. In a battlefield situation where ESM signals are complicated and the enemy situation is extremely fluid, in order to facilitate, through such processes as intuition, inference, prediction, decision making, and so on, the scientific gauging and evaluation of jamming effects, adoption is made of optimum electronic warfare order of battle and automatic writing and adjustment of release data tables, in order to achieve fully self-adjusting optimal jamming results, thereby reaching the level of artificial intelligence.

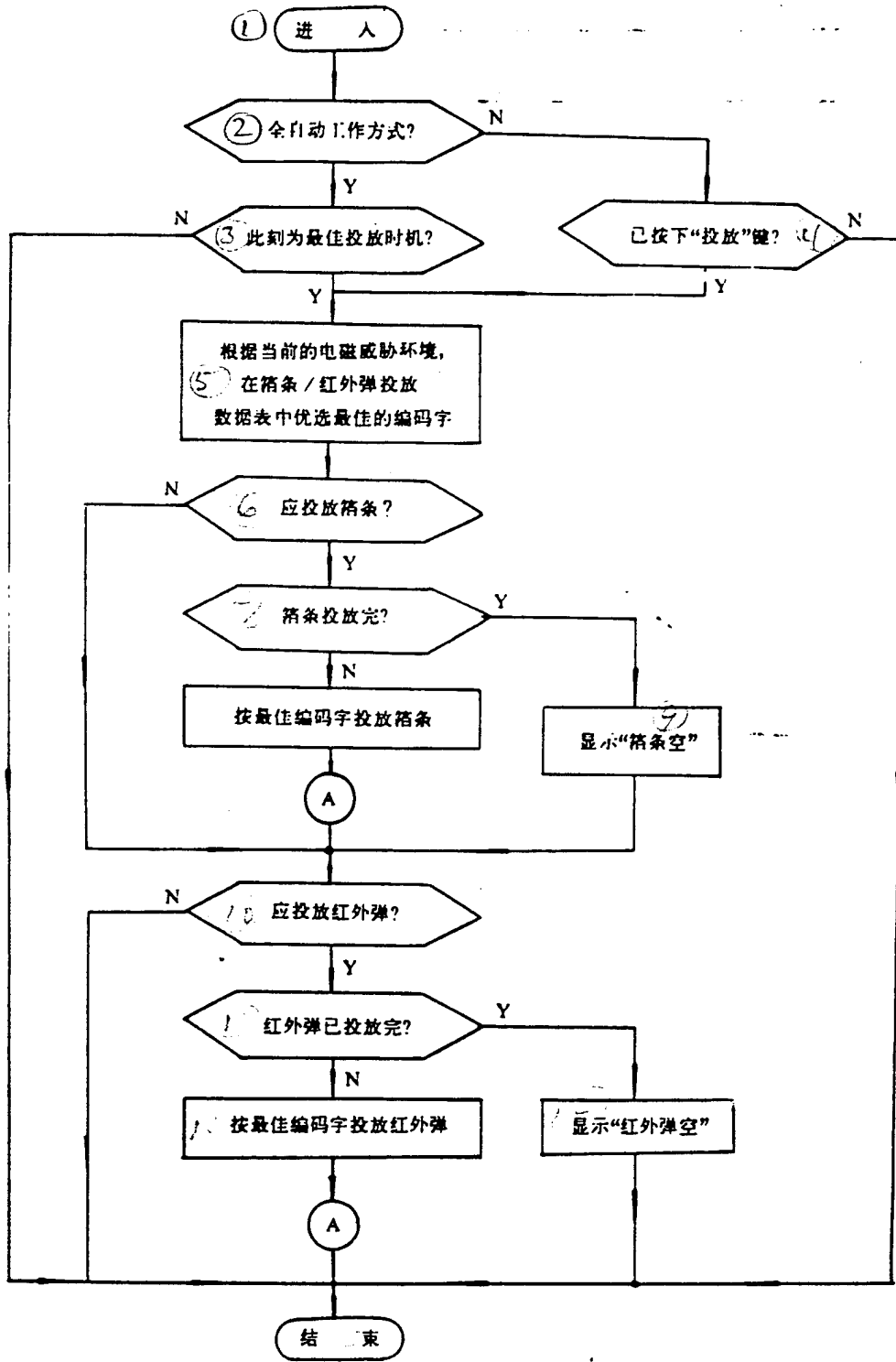

Fig. 6 (See Next Page)

Fig.6 Foil Strip/Infrared Missile Release Program Flow Chart (1)

Key: (1) Enter (2) Fully Automatic Operational Mode? (3) Is This Instant the Optimal Release Time? (4) Has the "Release" Key Already Been Pushed? (5) On the Basis of the Present Electromagnetic Threat Environment, in the Foil Strip/Infrared Missile Release Data Tables, Select the Optimum Code Characters. (6) Should Foil Strips Be Released? (7) Has Foil Strip Release Been Completed? (8) Release Foil Strips in Accordance with Optimum Code Characters (9) Displays "Foil Empty" (10) Should Infrared Missile Be Released? (11) Infrared Missile Release Already Complete? (12) Displays "Infrared Missile Empty" (13) Release Infrared Missile in Accordance with Optimum Code Characters (14) Terminate

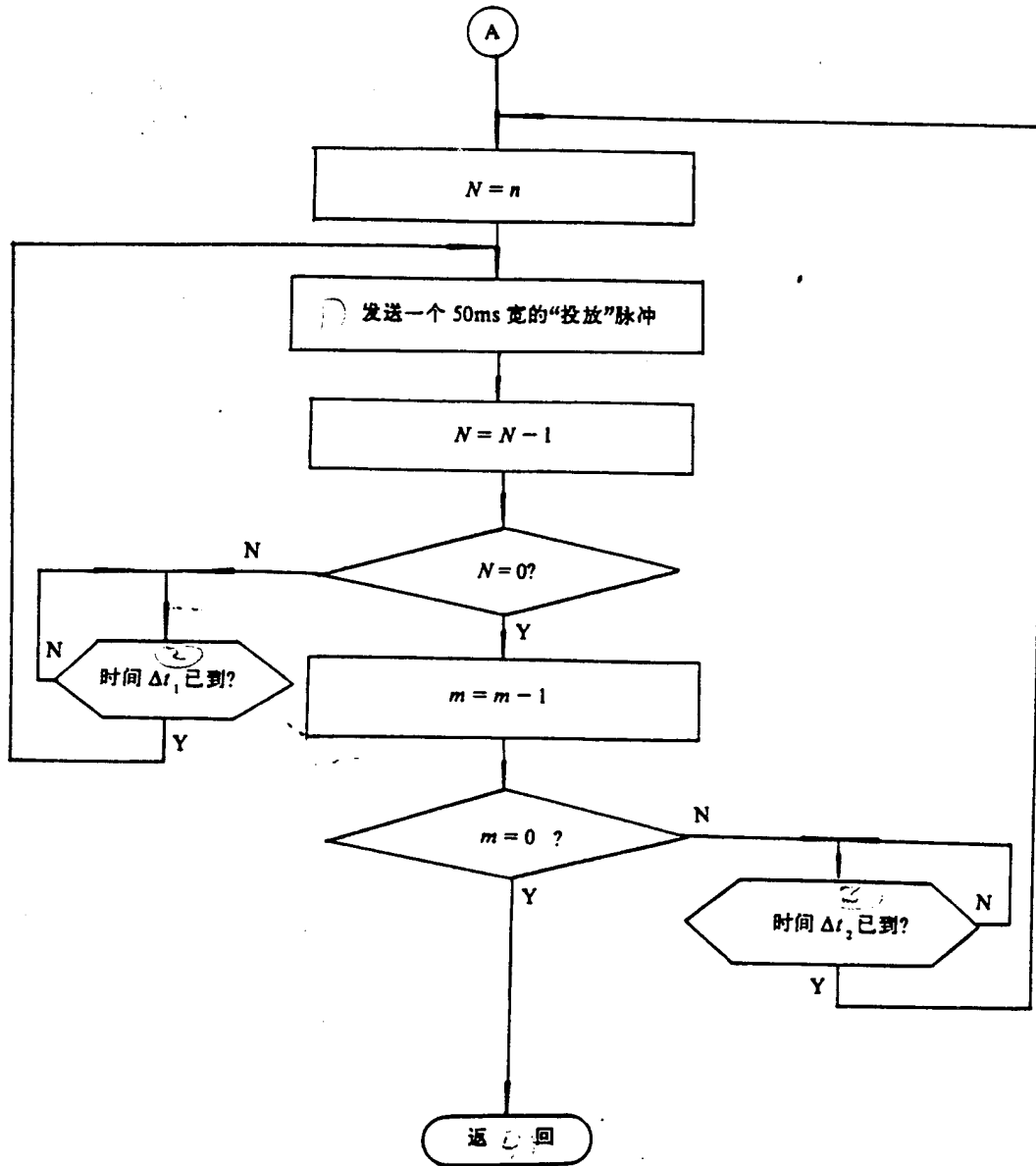

Fig. 7 (See Next Page)

Fig.7 Foil Strip/Infrared Missile Release Program Flow Chart (2)

Key: (1) Transmission of a 50ms Wide "Release" Pulse (2) Time  
Period Delta t1 Already Reached? (3) Time Period Delta t2  
Already Reached? (4) Go Back

Through the development of the systems in question, from empirical verifications among them to taking new and old airborne equipment and carrying out organic syntheses, it is possible to make use of the computer functions of new equipment to coordinate control of the operating processes of old equipment, improve the level of automation, and raise the efficiency of utilization as a whole. In this way, not only is the latent potential of new equipment exploited. In conjunction with that, the benefits of old equipment are brought into play and strengthened, making for sharing in the expenditure of resources, thereby probing for a practically feasible way to make use of and improve airborne equipment currently in service.

#### REFERENCES

- [1] 余农等,《一种改善航空电子系统电磁兼容性的有效方法》,系统工程与电子技术,1992年第1期。
- [2] 彭峰、余农,《自动检测》,中国广播电视出版社,1990年5月。
- [3] 朱水喜、余农,《航空工程检测技术》,科学出版社,1993年4月。

DISTRIBUTION LIST

DISTRIBUTION DIRECT TO RECIPIENT

<u>ORGANIZATION</u>	<u>MICROFICHE</u>
B085 DIA/RTS-2FI	1
C509 BALL0C509 BALLISTIC RES LAB	1
C510 R&T LABS/AVEADCOM	1
C513 ARRADCOM	1
C535 AVRADCOM/TSARCOM	1
C539 TRASANA	1
Q592 FSTC	4
Q619 MSIC REDSTONE	1
Q008 NTIC	1
Q043 AFMIC-IS	1
E404 AEDC/DOF	1
E410 AFDTC/IN	1
E429 SD/IND	1
P005 DOE/ISA/DDI	1
1051 AFIT/LDE	1
PO90 NSA/CDB	1

Microfiche Nbr: FTD95C000715  
NAIC-ID(RS)T-0382-95