

AFIT/GLM/LAL/95S-11



*RE-ENGINEERING THE ACQUISITION PROCESS OF  
MANUFACTURED ON-DEMAND ONLY SPARES*

THESIS

Mark E. Koesters

AFIT/GLM/LAL/95S-11

Approved for public release; distribution unlimited

19960104 205

The views expressed in this thesis are those of the author and do not reflect the official policy or position of the Department of Defense or the U.S. Government.

Accession For	
NTIS CRA&I	<input checked="" type="checkbox"/>
DTIC TAB	<input type="checkbox"/>
Unannounced	<input type="checkbox"/>
Justification .....	
By .....	
Distribution /	
Availability Codes	
Dist	Avail and/or Special
A-1	

AFIT/GLM/LAL/95S-11

***RE-ENGINEERING THE ACQUISITION PROCESS  
OF MANUFACTURED ON-DEMAND ONLY SPARES***

THESIS

Presented to the Faculty of the Graduate School of Logistics  
and Acquisition Management of the Air Force Institute of Technology

Air University

In Partial Fulfillment of the

Requirements for the Degree of

Master of Science in Logistics Management

Mark E. Koesters

December 1995

Approved for public release; distribution unlimited

## **Acknowledgments**

I would like to thank my thesis advisor Lieutenant Colonel Karen Currie who has exercised great patience and understanding in guiding me to completion of this research. I would also like to thank Doctor Alan Heminger who provided valuable insight into my research and also exercised great patience.

Most importantly I want to thank my wife Rebecca who has offered unceasing patience and understanding and without whose love and encouragement I could not have completed this research during this otherwise trying period of my life. Finally I wish to acknowledge my mom Betty who is always there when I need her and my dad Louie whose spirit is with me always.

Mark Koesters

## Table of Contents

	Page
Acknowledgments .....	ii
List of Figures .....	vii
List of Tables.....	viii
Abstract.....	ix
I. Introduction .....	1
Purpose .....	1
General Issue.....	1
Background.....	2
DoD Supply Pipeline.....	2
Business Process Re-engineering.....	5
BPR Initiatives.....	5
Research Justification .....	6
Problem Statement.....	7
Research Objective .....	8
Research Questions.....	8
Scope and Limitation .....	9
Methodology .....	10
Assumptions .....	11

	Page
Summary .....	11
II. Literature Review .....	12
Introduction.....	12
Defense Industrial Base.....	12
Initiatives.....	13
Electronic Commerce.....	13
Electronic Data Interchange.....	14
Federal Acquisition Computer Network (FACNET).....	15
Continuous Acquisition and Life-Cycle Support.....	16
Benefits of EC/EDI/CALS .....	16
Agile Manufacturing .....	17
Dual Use Technology.....	18
Technology Transfer.....	18
Virtual Organization .....	18
Solid Modeling .....	18
Agile Manufacturing Example.....	19
Contracting.....	20
Time and Materials Contract.....	21
Multiyear Contracts .....	21
Indefinite-Delivery Contracts (IDC) .....	22
Group Buys .....	22
Direct Vendor Delivery.....	22
Summary .....	23
III. Methodology.....	24
Chapter Overview.....	24
Research Questions.....	24
Data Collection Methodology .....	24
Data Collection.....	26
Validity.....	27

	Page
Reliability .....	27
Population and Sample .....	28
Data Analysis.....	29
Research Question 1 .....	29
Research Question 2 .....	29
Research Question 3 .....	29
Research Question 4 .....	29
Summary .....	31
 IV. Research Findings.....	 32
Chapter Overview.....	32
Research Question 1 .....	32
Research Question 2 .....	37
Electronic Commerce.....	38
Agile Manufacturing .....	38
Specialized Contracting.....	38
Research Question 3 .....	39
Electronic Solicitation.....	41
Agile Manufacturing .....	41
Specialized Contracting Methods .....	42
Research Question 4 .....	43
Summary .....	48
 V. Conclusions and Recommendations.....	 49
Chapter Overview.....	49
Conclusions .....	49
General Conclusions .....	49
Electronic Commerce Conclusions .....	50
Agile Manufacturing Conclusions.....	50
Contracting Conclusions .....	51

	Page
Recommendations.....	52
Embrace Electronic Commerce .....	52
Continue Agile Manufacturing Initiatives .....	52
Test Specialized Contracting Methods .....	52
Summary .....	53
Appendix A: List of Interview Questions .....	55
Appendix B: List of Acronyms.....	56
References.....	58
Vita .....	62

## List of Figures

Figure	Page
1.1 Traditional DoD Supply Pipeline.....	3
1.2 Weapons Systems Indicator Codes (WSIC) .....	4
1.3 Bellcrank .....	9
2.1 OC-ALC Agile Manufacturing Process .....	19
4.1 Current DGSC Acquisition Process (Unisys, 1995).....	33
4.2 Proposed Acquisition Process .....	40
4.3 Multiyear Contract Delivery Order Process.....	42
4.4 Relevant Factors.....	44

## List of Tables

Table	Page
3.1 List of Group NSNs .....	28
3-2 Sample Cost-Benefit Analysis.....	30
4.2 Lead-Times at DGSC (McCarty, 1995).....	35
4.1 Percentage of Annual Cost and Unit Cost Per Award by Phase, Task Area and Task for Product Center One (Clarke, 1995) .....	36
4.3 Cost and Benefit Analysis of Relevant Factors .....	45
4.4 Technology Transfer Costs (Kincaid, 1995).....	46
4.5 Logistics Response Time (James, 1995).....	46
4.6 Bellcrank Group Data (SAMMS) .....	47

**Abstract**

The purpose of this study is to explore potential alternatives to the current Department of Defense (DoD) acquisition process for low demand, high dollar value, not commercially stocked, spare parts in order to better utilize diminishing resources, reduce cycle costs, and sustain the defense industrial base. Demand for these items is insufficient to justify maintaining inventory, while the buy on-demand alternative results in long lead-times and increased costs due to the labor intensiveness of the current process, lack of willing manufacturing sources, and higher prices paid for small quantities of material. An exploratory case study method was used to study the Defense General Supply Center's (DGSC') acquisition process. Data gathered from secondary data review and from interviews with contracting and technical personnel was used to define the current process, hypothesize a better process, and to evaluate the costs and benefits of both processes. This evaluation lead to the conclusion that electronic commerce, agile manufacturing, and specialized contracting initiatives all have significant potential for improving the acquisition process. Recommendations were made for DGSC to continue research into using electronic commerce, agile manufacturing, and specialized contracting methods to improve the acquisition process.

# RE-ENGINEERING THE ACQUISITION PROCESS OF MANUFACTURED ON-DEMAND ONLY SPARES

## I. Introduction

### Purpose

The purpose of this study is to explore potential alternatives to the current Department of Defense (DoD) acquisition process for low demand, high dollar value, not commercially stocked, spare parts in order to better utilize diminishing resources, reduce cycle costs, and sustain the defense industrial base. In this study, potential alternate acquisition methods are reviewed and an alternate acquisition process is hypothesized, evaluated, and compared with the current acquisition process.

### General Issue

The collapse of the Soviet Union and the enthusiasm of the American government and its citizens to cash in on the post-cold war peace dividend have resulted in a steady erosion of the DoD budget. Yet, this reduction takes place at a time when the U.S. is facing an ever increasing threat of world-wide political instability. Since 1992, U.S. service personnel have performed major peacekeeping roles in Somalia, Macedonia, Haiti, and Bosnia. Also during this time, Air Force aircraft and personnel have been active in almost every country in the world (Widnall, 1995). However, since the completion of Operation Desert Storm in 1991, the DoD budget and personnel strength have declined precipitously. In the past ten years the overall defense budget has been reduced by 40 percent while procurement funds have been reduced by 65 percent (Preston, 1995). In brief, DoD must continue to provide logistical support to a more globally responsive force, but must accomplish this mission with fewer resources.

Another effect of the reduced defense budget is destabilization of the defense industrial base. The decreased budget has resulted in fewer dollars being spent on new weapons systems; therefore, defense contractors are experiencing declining revenues and profits. These companies are responding by reducing costs through industry consolidation, conversion to non-defense products, and decreasing capacity and employees (Gutmanis, 1994:73). The result is that DoD now has fewer suppliers, which could have a major impact on the cost and availability of systems and spare parts required to support the expanded global mission (Gansler, 1992:50).

### **Background**

DoD Supply Pipeline. DoD has for years relied on the traditional supply chain as shown in figure 1.1. Supplies are purchased in large quantities, stored in wholesale distribution depots and distributed to customers when requested. The focal point for management of spare parts is the Inventory Control Point (ICP). Each service has ICPs that are responsible for determining material requirements; acquiring, maintaining, and distributing stock; and maintaining technical data and system configuration controls. The service ICPs manage reparable spares and critical consumable spares which are items that are considered non-reparable.

The Defense Logistics Agency (DLA) is an independent DoD organization that manages consumable spares for the services. DLA manages over 90 percent of the military's consumable items and has inventory valued at over \$10 billion stored in over 1,400 warehouses at 27 depots (GAO, 1995:3). DLA ICPs also determine requirements and acquire, maintain, and distribute material. However, they must coordinate with the service ICPs before acquiring any parts that may alter any system configurations.

The General Accounting Office (GAO) has determined that DoD is maintaining an excessive amount of inventory because stock is also stored at the retail level in base

warehouses, central storage areas, and end user facilities. Therefore, stock turnover is low resulting in large amounts of obsolete and excess inventory. DLA depots keep on average enough stock to meet demands for 2 years. Retail facilities visited by GAO have stocks to cover demands ranging from 1 month to 5 years. By comparison, a typical private sector enterprise maintains much smaller inventories (GAO, 1995:5). The conclusion is that a large part of the DLA budget is consumed by inventory carrying costs.

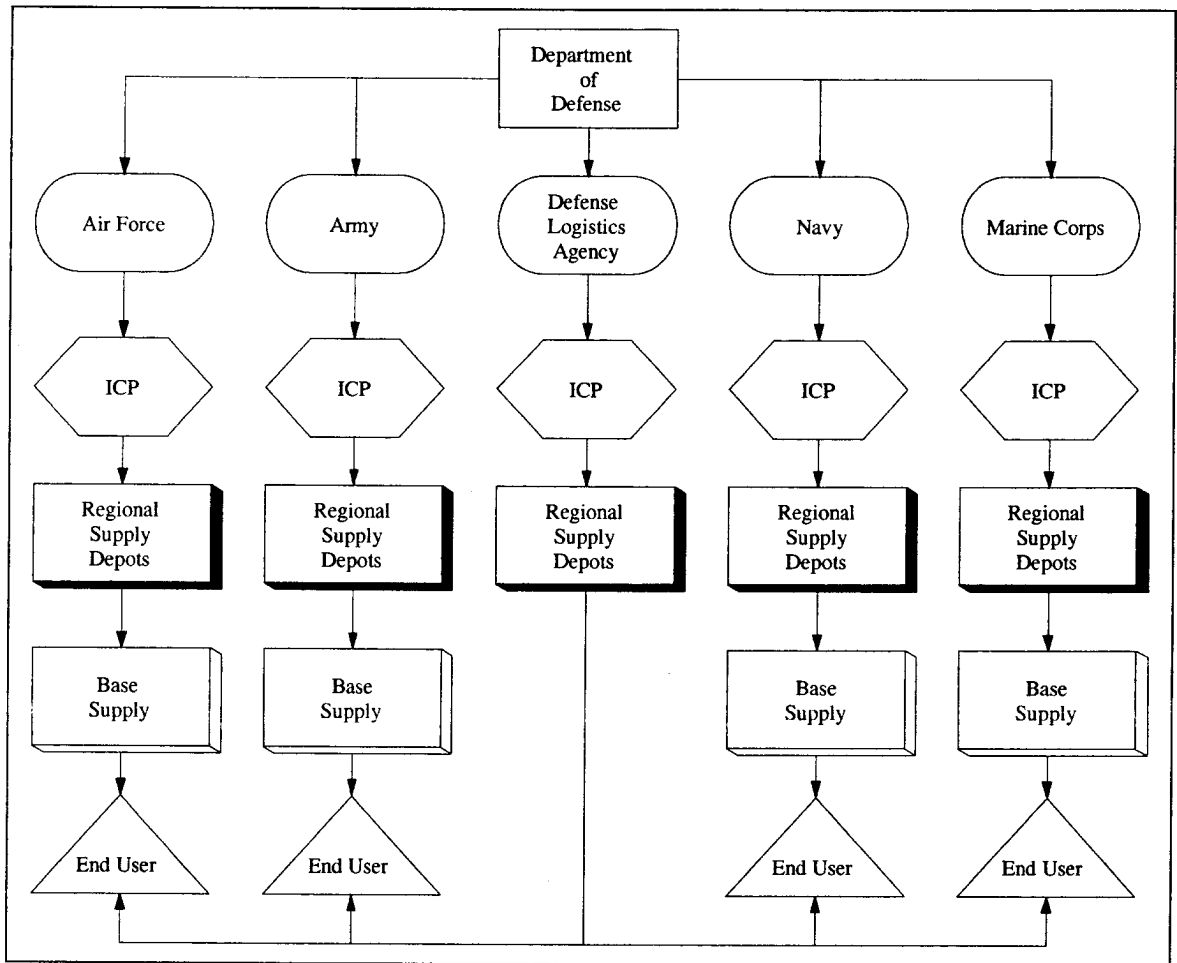

Figure 1.1 Traditional DoD Supply Pipeline

With responsibility for more than 3.6 million consumables to supply to the services, DLA has devised a stock management plan based on the essentiality of the system in which an item is configured and the criticality of the item to the system's availability and performance (see Figure 1-2). These criticality factors are determined by the managing services. DLA places greater management emphasis on those items that are coded Weapons System Essentiality Code (WSEC) 1 or that have high annual demand rates. Due to budget constraints, depot stock is being replaced at only 65% of current sales (James, 1995). Stock purchases will not be made for items in this category that have no demands for one year. Items that are not stocked are purchased upon receipt of a requisition and shipped directly to the requisitioner by the contractor .

WEAPON SYSTEM INDICATOR CODES (WSICs)						
WEAPON SYSTEM GROUP CODE	CRITICALITY	WEAPON SYSTEM ESSENTIALITY CODE (WSEC)				
		WSEC 1	WSEC 5	WSEC 6	WSEC 7	WSEC 3
		<b>A</b>	<b>MOST CRITICAL</b>	F	G	H
<b>B</b>	<b>CRITICAL</b>	L	M	P	R	S
<b>C</b>	<b>LEAST CRITICAL</b>	T	W	X	Y	Z

WSEC	DEFINITION
1	Failure to this part will render the item inoperable.
3	Failure to this part will not render the end item inoperable
5	Item does not qualify for assignment of Code 1 but is needed for personnel safety.
6	Item does not qualify for assignment of Code 1 but is needed for legal, climatic or other requirements peculiar to the planned operational environment of the end item.
7	Item does not qualify for assignment of Code 1 but is needed to prevent impairment of or the temporary reduction of operational effectiveness of the end item.

Figure 1.2 Weapons Systems Indicator Codes (WSIC)

GAO's emphasis on stock reduction and DLA's stock fund budget constraints have had a critical impact upon low demand, high dollar value items. These are items that

are often essential to system availability; but because reliability is typically high, demand is usually low. Therefore these items are usually stocked nominally or not at all. When an item of this type is non-commercial and out of production, acquisition and production lead-times may be lengthy. The result is that a critical system may be inoperable for an unacceptably long period of time.

The Defense General Supply Center (DGSC) is the DLA ICP for general support type items ranging from airframe components to furniture to hazardous materials. Its operations area is divided into six product centers responsible for managing items. This study will focus on Product Center One which is responsible for consumable airframe structural components. Many of these components are critical, low demand, high value items.

Business Process Re-engineering. Business Process Re-engineering (BPR) is a current management trend within the U.S. business community. Carr defines BPR as identifying core processes, and then making radical changes to these processes that result in dramatic improvement over current processes (Carr, 1995:7-13). This is a concept that is being embraced by the federal government through vice-president Al Gore's National Performance Review (NPR). The NPR has a goal of making government work better and cost less by encouraging adoption of best business practices to the federal government. GAO has determined that DLA could greatly reduce its inventory by using modern business practices to shift inventory responsibility to suppliers (GAO, 1995:5). As a result, DoD is researching new methods of providing logistical support in order to better utilize resources and to satisfy customer requirements (DoDb, 1994:3).

BPR Initiatives. DoD is already considering or has started implementing several of these initiatives. Electronic Data Interchange (EDI) is the automated computer to computer exchange of purchasing data. Studies have proven EDI to be simpler, faster and more accurate than the manual purchasing method. DoD and the rest of the federal

government are in the process of implementing EDI in every procurement office (Clinton, 1993:2175). Continuous Acquisition and Life Cycle Support (CALC) is a joint government and private industry initiative designed to convert technical data from a high maintenance paper format to an automated and integrated digital format for use in weapon system design and manufacturing support. The result is a technical database that is easier to access and easier to update. DoD has mandated that all technical data obtained with the acquisition of new systems must be delivered in digital format (Litman, 1995). Agile Manufacturing, sometimes known as flexible manufacturing, is the ability to use the same equipment to manufacture a wide variety of items in small quantities quickly and at a reasonable price (Bowlds, 1994:22). It is a technique that is greatly enhanced by DoD's effort to transfer government developed technology to private industry (Terino, 1994:39). DoD is also attempting to implement commercial contracting practices through the use of long-term indefinite quantity type contracts, group acquisitions, direct vendor delivery (DVD), and Just-In-Time (JIT) inventory delivery (GAO, 1995:18).

### **Research Justification**

Numerous studies have been conducted or are currently being undertaken that address each of these individual methods, but no single project has been undertaken to demonstrate how a combination of these initiatives could be used to attain significant improvement over existing logistics management and acquisition methods. This research project will attempt to evaluate the effects of integrating these diverse logistical techniques into the acquisition process. This research should demonstrate whether significant benefits can be realized from business process re-engineering and whether DoD should commit additional resources to further study of re-engineering the acquisition process.

## **Problem Statement**

The Defense General Supply Center, one of the Defense Logistics Agency's inventory control points, is faced with a declining operations budget, declining stock level authorization, and declining personnel levels. These decreased resources have affected the acquisition process for low demand, high dollar value items. The result has been increased costs, increased lead-time, increased delivery time, and increased wait time for the customer. There are several reasons for this problem. First is the stockage policy. These items are either nominally stocked or not stocked at all. Reorder points for the items are determined using the Economic Order Quantity (EOQ) method, but shortages can still occur because demand patterns are inconsistent. A single requisition for a large quantity or a sudden influx of requisitions for small quantities can quickly exhaust the available stock. This leads to the second reason which is the inefficiency of the existing acquisition process. The current process is labor intensive and time consuming which results in long administrative lead-times (ALT). ALT is the time elapsed from receipt of a demand to award of a contract. These items often have long production lead-times (PLT) due to special manufacturing requirements or the low priority often assigned to small quantity contracts by some contractors. PLT is the time from award of a contract to the government's receipt of the contract items. Another reason is that contractors sometimes choose not to bid for a contract because the item is obsolete or no longer profitable for them to manufacture. This requires DGSC to try to locate another manufacturing source or a suitable alternate item. This process adds to the ALT and oftentimes the PLT if a no source is located. The final reason is that the contract price for these items is typically high because they are usually purchased in small quantities and must absorb the contractor's set-up costs. Also, DGSC applies a surcharge to each item based on the commodity type. As a result of the current acquisition process, a DGSC customer may receive an abnormally high priced item in an untimely manner. This can be devastating to

a field unit that is also working within a reduced budget and that may have an urgent requirement for the item. This sort of acquisition problem is also common to the other DoD ICPs.

### **Research Objective**

The objective of this study is to identify a critical commodity managed by the DGSC that fits the problem criteria, and demonstrate that by revising the current acquisition process with such techniques as EC, EDI, CALS, agile manufacturing, technology transfer and commercial contracting, that acquisition costs, inventory carrying costs, and material lead-times can be reduced dramatically. This study should also demonstrate that additional manufacturing sources can be added to the defense industrial base. This study should also show that a re-engineered acquisition process will enable DGSC to pass lower costs along to the customer while providing greater responsiveness to its customers' needs. This research should also establish a basis for future study.

### **Research Questions**

1. What is the current acquisition process?
  - a. What costs are associated with the current process?
  - b. What are the measurement parameters of the current process?
2. What alternate methods are available?
3. What is a suitable re-engineered process?
  - a. What are the estimated costs associated with the re-engineered process?
  - b. What are the estimated measurement parameters of the re-engineered process?
4. How do costs and benefits of the proposed re-engineered process compare with those of the existing process?

### Scope and Limitation

The scope of this study is limited to the acquisition process at DGSC for a single group of bellcranks that fall within two Federal Stock Classes (FSC). Each FSC represents a grouping of items that are similar in function or application. Bellcranks fit into at least two classifications: FSC 1560, Airframe Structural Components and FSC 1680, Aircraft Accessories & Components, Miscellaneous. A bellcrank is a metallic object in the shape of two arms at an angle (see Figure 1.3). It is used to provide a means of changing the direction or varying the intensity of a pushing or pulling force. For example, bellcranks are a key part of the assembly that raises and lowers the landing gear on the B-1 aircraft.

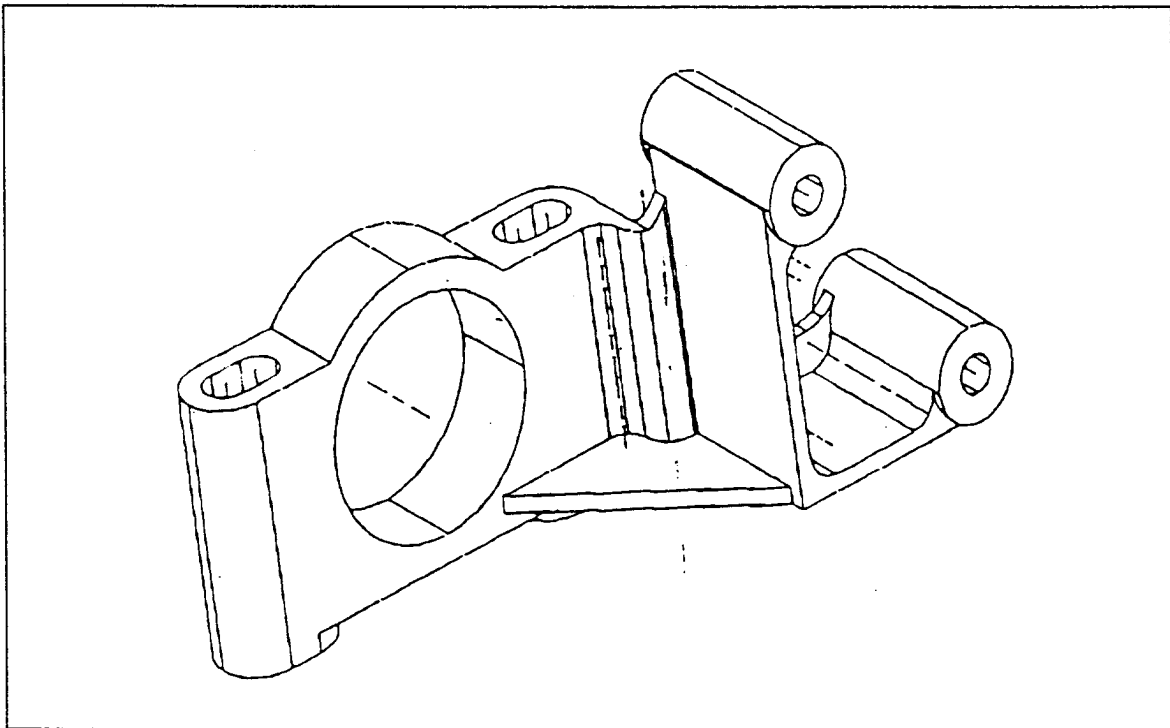

Figure 1.3. Bellcrank

This study is limited to a single type of item to facilitate development of a simple process model. Oklahoma City Air Logistics Center (OC-ALC) Technology Insertion Branch, the sponsor of this study, chose this commodity because bellcranks meet the problem criteria. They are critical to aircraft performance, yet demand often does not justify maintaining stocks of spare parts. Additionally, these items have similar physical characteristics and can easily be manufactured by commercial sources with the proper equipment. Therefore, bellcranks can best be used to demonstrate the effectiveness of the group buy, agile manufacturing, and technology transfer initiatives.

This group of items was identified as part of an ongoing effort at OC-ALC to identify items with similar physical characteristics and manufacturing methods. These items can then be combined into a single contract to gain economies of scale from lower material costs and from manufacturing different items without incurring additional set-up costs. Once the bellcrank commodity was selected as suitable for testing, DGSC was recruited into the test project because it is the ICP for bellcranks.

### **Methodology**

The methodology for this study is an exploratory case study format. Discussions with DGSC and OC-ALC personnel and review of documents and historical data will be used to model the current acquisition process at DGSC. Discussions with DGSC and OC-ALC personnel and review of literature will be used to find potential methods of improving the acquisition process. A potentially more effective acquisition process will be hypothesized. A cost and benefit analysis approach will be used to evaluate the performance of both processes.

Exploratory studies are used to develop hypotheses or research questions for future research. They are also useful for studying areas that are broad or where the issues are vague (Cooper and Emory, 1995:117-118). The exploratory case study methodology

is appropriate for this research because there is no record of any studies involving a combination of these initiatives. The objective of this study is to establish a basis for future research.

### **Assumptions**

- DGSC acquisition process is the same for all commodities.
- DGSC will continue to identify and group similar items.
- OC-ALC will continue to assemble a technical knowledge base for these items.
- EDI capability will eventually be implemented per President Clinton's directive.
- EDI access to solicitations will be afforded to any business that wants it.

### **Summary**

The purpose of this study is to explore methods of changing the DoD acquisition process of low demand, high dollar value, not commercially stocked spare parts. This process can be re-engineered using best business practices. The objective of this study is to demonstrate that cost and time savings can be generated as a result of the re-engineered process. The exploratory case study method will be used. The next chapter provides additional background and justification for this study.

## **II. Literature Review**

### **Introduction**

The problem as defined in the previous chapter is how to make the acquisition of consumable spare parts more cost effective and more time efficient even though procurement resources have been dramatically reduced. To solve this problem, the acquisition process must be re-engineered by utilizing best business practices and DoD mandated initiatives. A literature review was conducted to illustrate the problems with the current acquisition process and to locate initiatives or techniques that could be used to improve the process. These initiatives fall into three categories: electronic commerce, agile manufacturing, and contracting. Potential improvements in electronic commerce include electronic data interchange and Continuous Acquisition and Life-Cycle Support. Potential improvements within agile manufacturing include technology transfer, dual use technology, solid modeling, and virtual organization. Contracting initiatives include multiyear contracts, indefinite delivery contracts, time and materials contracts, direct vendor delivery (DVD), group buys, and the just-in-time (JIT) inventory system. This chapter presents background on the condition of the defense industrial base and also provides background on the above mentioned initiatives.

### **Defense Industrial Base**

The defense industrial base is the segment of the manufacturing industrial base that develops and manufactures systems and spare parts for the Department of Defense. For the majority of these manufacturers, DoD contracts account for most of their business. Because the reduced defense budget has resulted in reduced spending for acquisition, many defense contractors have been forced to decrease in size, merge with other contractors, switch to commercial appeal items, or cease operations all together. The

result is fewer defense manufacturers and reduced defense manufacturing capacity (Bowlds, 1994:2).

Maintaining the defense industrial base is crucial because future wars are likely to be regional and short in duration owing to the loss of the Soviet Union as a major threat (DoDc, 1994:8). These wars will be fought largely with existing inventory. If additional spares and replacement parts are needed, the current defense industry may not be capable of supplying them in a timely manner (Bowlds, 1994:4). Also, a smaller industrial base could force DoD to rely increasingly on foreign sources of supply which could affect availability or create sole source situations which could greatly increase material costs (Bowlds, 1994:10).

Therefore, defense industrial policy goals are to maintain a strong manufacturing base, ensure production surge capability, continue to develop unique technology, and maintain competition among defense contractors. Possible methods of achieving these goals include dual-use technology, technology transfer, low rate acquisition, concurrent engineering, and agile manufacturing (Heberling, 1994:238).

### **Initiatives**

Electronic Commerce. Electronic commerce (EC) can be defined as the use of technology to convert business transactions from a paper-based system to a paperless system through the use of electronic data interchange, electronic mail, and electronic bulletin boards. An expanded definition of electronic commerce includes the use of facsimile transmissions, on-line computer networks, and advanced computer software and hardware. Electronic commerce uses the unique abilities of people and the speed and reliability of machines to enhance business practices and to facilitate exchange of business information. Examples of interactive EC activities are concurrent engineering where engineers at multiple locations can simultaneously access technical data on-line, and

enterprise integration which enables organizations to exchange data more effectively within their own organization or with suppliers (Rosener, 1994:25).

Electronic Data Interchange. One of the components of EC is electronic data interchange which is the computerized transfer of business transactions between organizations in an agreed upon format. Transactions are processed entirely by machines without human intervention (Emmelhainz, 1990:5). Documents must be arranged in a format that can be understood by connected computers (Anderson and Payne, 1991:1). Some documents that can be sent via EDI include acquisition documents such as requests for quotation (RFQ), responses to RFQs, purchase orders, purchase order acknowledgments, shipping notices and invoices. Transportation transactions include bills of lading and freight invoices (Emmelhainz, 1990:18). There are two essential requirements for successful EDI transmission: format standards and third party providers.

Business correspondence formats differ among companies because they are designed to meet the needs of their individual record keeping systems which are reviewed and interpreted by people. However, for EDI to be successfully interpreted by computers, communications must be transmitted in a format that can be easily distinguished by another computer. Standards define which documents can be transmitted, what information can be included, the format and sequence of data, and the coding of data. Individual organizations can develop their own standards and require their trading partners to use them (Emmelhainz, 1990:63-65). DoD is using a standard developed by the American National Standards Institute (ANSI) known as ASC X12. Standards for specific transaction documents are known as conventions (DoDf, 1991:11). Individual conventions are given standardized identification numbers. For instance, a purchase order transaction is known as an 850 (Anderson and Payne: 103). A purchasing organization would use the 850 convention to use EDI to issue a purchase order to a trading partner.

Another EDI exchange standard is Electronic Data Interchange for Administration, Commerce and Transportation (EDIFACT). This standard is being developed by the United Nations and is gaining universal acceptance internationally (Chmielewski, 1995). The CALS Industry Steering Group has recommended that DoD adapt its EDI system to accept EDIFACT transaction sets as well as ASC X-12 transaction sets. This will ensure that the DoD system is compatible with international EDI systems (DoD Urged to Work, 1995:324).

Third party providers are required because direct transmission lines between trading partners can be limiting and expensive if a business has many EDI trading partners (Emmelhainz, 1990:17). Value Added Networks (VANs) provide a valuable electronic link between trading partners. A VAN operates electronic bulletin boards where requirements can be posted by one organization and reviewed by many others. A VAN is also a central receiver that sorts mail from many sources into individual mailboxes where organizations can access transactions with only one phone call. VANs will also translate normal business data into EDI format before sending a message to a mailbox (DoDf, 1991:4).

Federal Acquisition Computer Network (FACNET). The Federal Streamlining Act of 1994 (FASA) was enacted to encourage federal agencies to simplify the acquisition process. FASA established the Federal Acquisition Computer Network. FACNET will enable federal agencies to use EDI almost exclusively for acquisitions. In order to do this, FACNET increases the small purchase threshold from \$25,000 to \$100,000; reserves all acquisitions between \$2,500 and \$100,000 for small business; does not require notice in the Commerce Business Daily (CBD); and, shortens the solicitation open period. FACNET also encourages acquisition of commercial items when available instead of specially designed items (Lamb, 1995:18). This process should widen the industrial base and lead to decreases in both ALT and PLT.

Continuous Acquisition and Life-Cycle Support. CALS is a joint government and private industry initiative designed to convert technical data from a high maintenance paper format to an automated and integrated digital format for use in weapon system design, manufacturing, and support (Hunt, 1991:48). Defense contractors have been required to provide technical data and technical manuals in digital format since 1988 (Continuous Acquisition, 1995:6). CALS has fostered development of digital technical data packages (TDP) consisting of engineering drawings, parts lists and other specifications that are required for review by contractors prior to submitting their bids (Hunt, 1991:148). Because there was no common system for exchange of digital data, one of the CALS initiatives was to develop and test standards for exchange of digital tech data (Hunt, 1991:48). CALS has been a complementary program to EDI in development of standards for exchange of TDPs. The result is that ASC X12 convention 841 has been developed to provide standards governing the exchange of digital technical data required to perform defense missions (DoDf, 1991:1). This means that digital technical data packages can be forwarded with a request for quotation.

Benefits of EC/EDI/CALS. There are numerous benefits that result from using electronic commerce. They include reduced transaction times, increased accuracy, reduced costs, and an increased data supplier base. Transaction times are reduced because EDI is faster than conventional information exchange means such as mail and facsimile. Because EDI requires no human intervention, accuracy is increased by eliminating the need for re-keying data. Savings result from a reduction in personnel required to process purchase requests and from a reduction in inventory as a result of shortened procurement lead-times. EDI also complements JIT systems by enabling rapid and accurate exchange of the customer's material requirements. EDI can also enable more efficient use of company resources by providing timely and accurate information pertaining to material, inventory, and cash management (Arunachalam, 1995:61). The supplier base is increased

because EDI allows for advertising of requirements over a larger geographical area. Savings are realized from reduced prices as a result of the increased data supplier base (Rosener, 1994:27).

Anderson and Payne describe five ways that the Department of Defense (DoD) can benefit from increased use of EC. EDI will shorten procurement administrative lead time and result in reduced inventory requirements. EC can increase DoD's industrial base by reaching out to more potential sources and by reducing the effort required by sources to do business with DoD. EC can be used to notify contractors of changes in priority and to ensure faster delivery. EC allows for better control of material flow in the transportation pipeline through increased visibility of each transaction. Finally, EDI allows better control of unpredictable surges in demand by increasing visibility to potential suppliers and by allowing higher visibility to the supply pipeline (Anderson and Payne, 1991:16-54). CALS combined with EC allows for rapid transmission of required TDPs to potential government contractors which results in increased competition, lower prices, and decreased lead times (Anderson and Payne, 1991:5).

Agile Manufacturing. One potential method for ensuring availability of sufficient quantities of quality spare parts without maintaining inventory is through the use of agile manufacturing. Agile manufacturing, sometimes known as flexible manufacturing, is the ability to manufacture small quantities of an item quickly and at a reasonable price. Agile manufacturing can provide reductions in production lead time, inventory and manufacturing costs (Goldman and others, 1995:3).

A successful agile manufacturing program requires 'modular, flexible, re-configurable, affordable production processes and equipment (Nagel, 1992:8). Other requirements are large and accurate knowledge bases, capable computers, and the ability to model and simulate production processes. Also required is the ability to obtain and share information quickly and accurately with partners and customers. Cooperation

between partners is also required in order to share risks, unique resources and knowledge (Nagel, 1992:8).

Dual Use Technology. Dual Use Technology is the adoption of commercial technology to military applications. Dual use programs are designed to incorporate commercial technology into defense systems and to transfer defense developed technology to the private sector. In many areas of technology development, commercial development is ahead of defense technology development. In other areas, defense is ahead. By using commercial technology, DoD benefits from using less expensive standardized state of the art components instead of developing special items to military specifications (DoDd, 1995).

Technology Transfer. Technology transfer is the sharing of government developed technology with private industry. By transferring technology to the private sector, DoD benefits by developing new sources of supply that are not dependent on DoD for their survival (DoDe, 1994:17).

Virtual Organization. A virtual organization is a group of individuals or organizations who come together for a short period of time to lend their individual expertise to a common project. Upon completion of the project, the organization dissolves. Suppliers, customers, government, non-profit groups, even competitors can form a temporary partnership in order to quickly capitalize on a specific opportunity. Advanced computer and communications technology are used to enable the partners to share knowledge, skills, and costs (Byrne, 1993:19).

Solid Modeling. Existing technical data can be incorporated into a computer program that will construct a solid model of a machined part. The models can then be manipulated to meet the needs of a variety of manufacturing systems. The computer generated solid models can then be used to capture manufacturing planning, tooling, and Computer Numerical Control (CNC) tasks. The CNC manufacturing process uses

computer technology to provide a machine tool with the dimensions of a part and with the manufacturing knowledge that the machine requires to determine and perform the tasks that automatically produce a metal part. A program with all the necessary data is generated by a computer and then fed into the operating system of the machine tool. A CNC tape instructs the machine exactly what to do by providing such information as what shape to create, what type and size tool to use, location and size of the shape, and the acceptable tolerances. Programs can be easily loaded and unloaded thus decreasing set-up time (I-DEAS, 1993:28).

Agile Manufacturing Example. The Oklahoma City Air Logistics Center has been using agile manufacturing since 1992 to speed up the manufacturing process of machined spare parts for disabled aircraft. The process is illustrated in Figure 2.1. Critically needed, small quantity parts that cannot be obtained quickly by any other means are identified and forwarded to the OC-ALC Technology Insertion (TI) Branch . TI then uses a computer aided design (CAD) system to build a technical knowledge base for the required part. The CAD system is then used to build a solid model that captures and defines the features of the part such as a hole or slot. The CAD system can then be used to run a rules based program that will design a tool path that can be used on a computer operated machining tool. The CAD system also generates a CNC program tape that is forwarded to the OC-ALC Manufacturing Branch (LI) to be used in production of the critical part (DoDa, 1994).

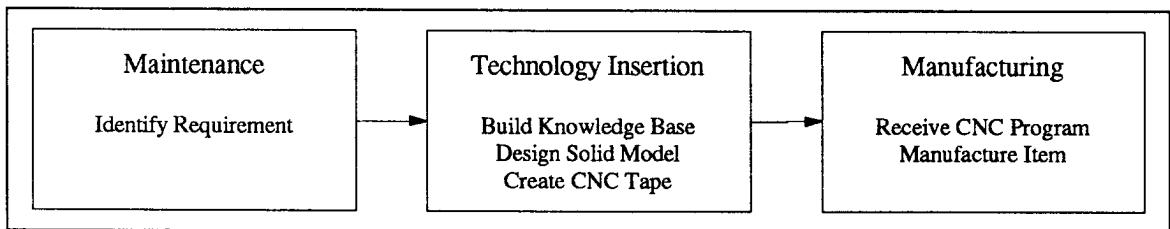

Figure 2.1 OC-ALC Agile Manufacturing Process

The previous manufacturing process required that CNC program tapes be programmed manually. A CNC tape that would program a machine to make a bellcrank typically required up to 37 days to create while actual production would take just 5 days. Creating the CNC tape accounted for 88 percent of the manufacturing process time.

By contrast, TI has used the new CAD based process numerous times to decrease the CNC program tape creation process. One successful example is a bellcrank used on the C-130 transport aircraft. TI designed the program in just one day and needed only 10 days to create the CNC tape. LI manufactured the item in six days. The total production process required only 17 days, which is a 51 percent improvement over the previous production process (DoDa, 1994).

TI is working to identify manufacturing methods that are most common. These methods can then be broken down into rules that can be used to hasten the generation of a CNC tape. TI hopes to improve on its success by exporting its knowledge to private industry using the virtual organization to perform partnerships with small business. TI will be able to transfer its technology in the form of a knowledge base, solid model, or CNC program to small businesses. The data packages will be capable of being transmitted electronically. In exchange the government will receive its parts faster and expand the military industrial base (DoDa, 1995).

### **Contracting**

DoD contracts for supplies or services can be issued on a one-time basis or on a long term basis. Short term contracts are issued for a definite quantity or service and is considered complete upon completion of the contract requirements. These are used when immediate requirements for an item or service are known or if items are going to be kept in inventory. Long-term contracts can be issued for definite or indefinite quantities of material for a multiyear period. These are used when required quantities are not known,

when inventory is not maintained, to reduce administrative costs of issuing multiple purchase orders, and to reduce lead time. Delivery orders for specific quantities are issued against long term contracts (Breen, 1993:14). Contracts can be firm-fixed price where the contractor is paid a negotiated price; or they can be cost reimbursement where the contractor is paid costs incurred in performance of the contract plus a fee. The fee may be fixed or a percentage of cost (Aranavas and Ruberry, 1994:2-19).

Time and Materials Contract. Time and Materials is one type of cost reimbursement contract. The contractor paid for the labor and material used in performance of the contract. Fixed labor rates are negotiated in advance and include profit and overhead. Material is reimbursed at the contractor's cost and may also include material handling costs. This type of contract is normally used only when the extent and duration of work are unknown, such as a maintenance contract (Aranavas and Ruberry, 1994:4-24). The Federal Acquisition Regulation states that this type of contract provides the contractor with no profit incentive to control costs and labor efficiency. Also it requires more active government oversight. FAR also states that time and materials contracts may only be used after the contracting office determines that no other contract type is suitable and if the contract contains a cost limit that the contractor cannot exceed (FAR, Part 16).

Multiyear Contracts. Multiyear contracts are contracts that are issued for more than one year but cannot exceed five years in length and may be used for the acquisition of supplies or services. The contracts are financed one year at a time and must be canceled if expected funding does not occur. They are used to lower costs, reduce administrative burden by reducing frequent recurring negotiated purchases, broaden the competitive base by attracting companies that are not interested or cannot compete at a smaller quantity, encourage contractors to invest in capital goods or technology. A fixed-price or fixed-

price incentive type contract instrument must be used for multiyear contracts (FAR, Part 17).

Indefinite-Delivery Contracts (IDC). An indefinite-delivery contract is used when exact requirements are not known. They are issued for a specific period of time and may be multiyear. Contract price and delivery are negotiated in advance. A delivery order is issued to the contractor for a specific quantity when a requirement arises. Advantages include reduction in stock to minimum levels, flexibility in quantities ordered and delivery time, reduction of risk if requirements change or technology changes. They also encourage contractors to maintain stock if they know they will be the only source of supply. One type of IDC is a requirements contract. The government agrees to purchase all of its requirements from one source for a fixed period of time. The government estimates its requirements, but does not guarantee the quantity of sales. The government may also issue an indefinite quantity contract. Again the government estimates its requirements, but also agrees to purchase a minimum quantity. Purchase requirements are not limited to a single source (FAR 16).

Group Buys. Multiple items that are similar in material or manufacturing methods can be grouped together and bought on a single contract. One benefit of this type of acquisition is lower prices because the contractor can obtain lower prices for material purchased in larger quantities. Another benefit is shorter lead-times because if the items use similar manufacturing methods or equipment, the contractor can reduce set-up times required to switch to a different item.

Direct Vendor Delivery. Direct vendor delivery (DVD) contracts require a contractor to ship directly to the requisitioner instead of to a depot. This enables the ICPs to take advantage of the just-in-time delivery theory. The exact amount of material required for production is delivered to the right location only when it is needed. The benefits of JIT are reduced inventory, increased flexibility, improved product quality, and

increased productivity. Also a close customer/supplier relationship is fostered. (Banerjee and Golhar, 1993:22). Non-manufacturers can also benefit from JIT philosophy. Service organizations such as hospitals can reduce costs by maintaining small inventories of supplies that can be replenished on a regular basis by a third party provider. DLA is using DVD for high volume commercial type items (GAO, 1995:27).

### **Summary**

This literature review has described a number of process improvement ideas that have been shown to work individually or in combination with other initiatives. However, there is no record of any study attempting to demonstrate the cost effectiveness of implementing a combination of these initiatives in order to reduce acquisition costs, administrative lead-time, production lead-time, and inventory, and to increase the size of the defense industrial base. The next chapter presents the research methodology.

### **III. Methodology**

#### **Chapter Overview**

This chapter describes the methodology that was used in researching this study. The research questions are restated because they drive the research. The data collection methodology is explained and justified. Validity and reliability are established. The population and research sample are defined. The data analysis methodology is outlined and explained. Finally, the chapter is summarized.

#### **Research Questions**

This study was designed to answer the following questions:

1. What is the current acquisition process?
  - a. What costs are associated with the current process?
  - b. What are the measurement parameters of the current process?
  - c. What are the weaknesses of the existing acquisition process?
2. What alternate methods are available?
3. What is a suitable re-engineered process?
  - a. What are the estimated costs associated with the re-engineered process?
  - b. What are the estimated measurement parameters of the re-engineered process?
4. How do costs and benefits of the proposed re-engineered process compare with those of the existing process?

#### **Data Collection Methodology**

The exploratory case study method was selected because the objective of this research is to evaluate the potential benefits of a hypothetical process and to establish a

basis for further research. This objective was selected because there has been no single study undertaken to demonstrate how the acquisition process could be improved through the use of a combination of BPR initiatives.

The case study method is justified because it enables the researcher to place greater emphasis on a single environment and how its elements interact. Data can be collected in greater detail and provide valuable insight for problem solving, evaluation, and strategy (Cooper and Emory, 1995:116-117). The case study method should demonstrate whether the re-engineered process will solve current problems for a single commodity at a single location and whether this strategy should be tested for other commodities and at other ICPs.

The exploratory method is too often overlooked and undervalued by management because it is considered subjective, non-representative, and unscientific. However, this method is justified by Cooper and Emory, who believe that exploration is useful for developing concepts, establishing priorities, and improving the final research design. An exploratory study will also save resources if research indicates that further research is not warranted (Cooper and Emory, 1995:118). The exploratory method should demonstrate whether the benefits of the re-engineered process are deserving of further study.

Exploratory studies can employ both qualitative and quantitative research techniques. Possible exploratory research methods include case studies, participant interviewing, document analysis, and review of secondary data (Cooper and Emory, 1995:118-121). This study employs both qualitative and quantitative techniques. This is a qualitative study because the initiatives incorporated into the proposed re-engineered process are selected subjectively. However, part of the selection process is based on estimated savings which is quantitative data. A quantitative cost-benefit analysis will be performed based upon identification of costs and benefits of the current process and identification and development of estimated costs and benefits of the re-engineered

process. However, the method of determining estimated costs and benefits is also a subjective process. Because a proposed process model is being evaluated, no actual performance data exists. Therefore evaluation must be performed using data collected from existing sources such as historical documents, secondary data, and interviews with knowledge-specific field experts.

### **Data Collection**

Unstructured interviews and informal discussions were held with DGSC contracting and technical personnel and with employees from OC-ALC contracting and engineering offices in order to determine the structure, costs, and performance measures of the existing acquisition process. Information pertaining to problems with the current process and ideas for improving the process were also obtained. Discussions were open-ended in order to promote free exchange of ideas. Questions asked are listed in Appendix A.

Discussions were also conducted with contracting personnel from the Defense Electronics Supply Center (DESC) and DGSC to obtain their experiences with electronic commerce and contracting initiatives. Discussions were open-ended in order to promote free exchange of ideas. Questions asked are listed in Appendix A.

Secondary data was reviewed and produced a number of ideas for improving the acquisition process. Secondary data also provided insight into potential costs and benefits of these alternatives. The literature review was wide-ranging to ensure inclusion of all reasonable alternatives and included books, journals, magazines, pamphlets, lectures, and published reports.

Historical data was reviewed in order to obtain cost and measurement parameters for the current process. Historical performance data was obtained from key personnel at DGSC. Historical data was also reviewed to discover contract history, price history, and

demand history for the sample National Stock Numbers (NSN). This review consisted of interrogation of DLA's Supply Automated Material Management Subsystem (SAMMS) which is a comprehensive database of DLA's acquisition, supply, technical, and quality assurance transactions.

### **Validity**

Yin cites four methods for judging the quality of research designs: construct validity, internal validity, external validity, and reliability (Yin, 1989:40-41). Reliability will be covered in a subsequent section.

Construct validity is the assurance that the concept being studied is measured properly. Tactics for ensuring construct validity are: use multiple sources of evidence; establish a chain of evidence; have key informants review draft report (Yin, 1989:41-42). Construct validity for this study will be determined by maintaining a chain of evidence that will lead an outside observer to arrive at the same conclusions.

Internal validity is the establishing of causal relationships and is not applicable to exploratory studies (Yin, 1989: 40).

External validity determines whether a study's conclusions can be generalized to similar situations. This is usually thought to be true, but can only be confirmed through replication of study in different locations (Yin, 1989:43-44). Because the problems experienced by DGSC are the same as those experienced by other ICPs, the conclusions reached by this study should be applicable to the other ICPs. This research could be validated by further research.

### **Reliability**

Yin defines reliability as being able to repeat the operations of a study and obtain the same results. Reliability can be ensured by using a case study protocol or by

maintaining a case study database (Yin, 1989:41, 45). Reliability of this study will be ensured by maintaining a research database.

### **Population and Sample**

The population of this study is all DoD Inventory Control Points for consumable spare parts. Because this is an exploratory study and the objective is to evaluate one possible solution, the sample is limited to the acquisition process of a single group of six NSNs by DGSC. The OC-ALC Technology Insertion Branch selected this class of NSNs because they believe it can best demonstrate the group buy, agile manufacturing and technology transfer initiatives. The six NSNs in the acquisition group were selected based on similarity of their material and of their manufacturing methods. The six NSNs are listed in table 3.1.

Table 3.1 List of Group NSNs

<b>Nomenclature</b>	<b>National Stock Number</b>
Bellcrank	1560-01-173-3287
Bellcrank	1560-01-174-1688
Bellcrank	1560-01-174-4865
Bellcrank	1560-01-203-7321
Bellcrank	1560-01-299-3618
Bellcrank	1680-01-369-7018

## Data Analysis

### Research Question 1. What is the current acquisition process?

This research question was answered through discussions with DGSC and OC-ALC personnel and by reviewing historical records. A process review team of DGSC and contractor personnel devised an IDEF (Modeling language support by DoD) model of the current acquisition process. DGSC personnel also provided data showing the cost for performing each function and provided measurement parameters by which the process effectiveness is evaluated.

### Research Question 2. What alternate methods are available?

This research question was answered by conducting an in-depth review of secondary data to determine those initiatives that may be applicable to the DGSC acquisition process. DGSC, DESC, and OC-ALC personnel were also asked for ideas. Consideration was given to those initiatives that demonstrated reduction in lead-time and costs, ease of applicability, or contribution to the maintenance of the military industrial base.

### Research Question 3. What is a suitable re-engineered process?

This research question was answered through interviews and discussions with DGSC, DESC and OC-ALC personnel to determine the appropriateness of initiatives to the re-engineered process. After a re-engineered process was determined, estimated cost and performance figures were determined based on quantitative figures obtained from the secondary data review and each measurement criterion relevant to the current process was assigned a range of values.

### Research Question 4. How do costs and benefits of the proposed re-engineered process compare with those of the existing process?

This final research question was answered through comparison of the relevant factors of the two processes. Relevant factors are those that differ among alternative

courses of action. In this case the relevant factors are the different methods of accomplishing the same acquisition tasks, for example: electronic solicitation instead of manual solicitation.

Relevant factors can be quantitative or qualitative. Quantitative factors can be financial or non-financial (Horngren, 1994:389). This analysis considers both types of quantitative data. Financial data such as cost to award a contract was obtained and evaluated for potential savings. Non-financial data such as ALT and PLT were also analyzed. Qualitative factors cannot be measured in quantitative terms (Horngren, 1994:389). Qualitative factors are more difficult to evaluate because of difficulty in obtaining an accurate financial measurement (Horngren, 1994:390). However, attempts were made to evaluate qualitative factors such as the higher costs involved in providing technology to a contractor against the value of reduced production lead-time.

A standard cost and benefit analysis spreadsheet format was used (Figure 3-2). This form is divided into sections: cost and performance. Relevant factors are listed in column one, costs for the current process in column two, lead-time for the current process in column three, cost for the re-engineered process in column four, and the lead-time for the re-engineered process is shown in column five.

Table 3-2 Sample Cost-Benefit Analysis

Phases	Current Process	Current Process	Re-engineered Process	Re-engineered Process
	Cost	Lead-Time	Cost	Lead-Time
Solicitation	\$ 20.00			
Quote Evaluation	\$ 10.00			
Award	\$ 20.00			
<b>Total</b>	<b>\$ 50.00</b>			

A subjective benefit analysis was also performed. It details qualitative benefits or costs that may occur as a result of the re-engineered process. An example of a qualitative benefit is an increase in the size of the defense industrial base or a number of small

businesses increase their sales as a result of increased access to DoD solicitations and subsequent contracts.

### **Summary**

In this study, the case study method is being used to determine the current acquisition process and to identify a potentially more effective re-engineered process. Both processes will be quantitatively and qualitatively evaluated in order to determine which process is more effective by using the cost-benefit analysis method. The results of this analysis are presented in the next chapter.

## **IV. Research Findings**

### **Chapter Overview**

This chapter presents the findings obtained from the case study research methodology described in the previous chapter. Data obtained from the informal discussions, historical review, and secondary data review were analyzed to provide the basis for the findings presented. The data and findings are presented in the form of responses to each of the investigative research questions.

### **Research Question 1**

What is the current acquisition process?

- a. What costs are associated with the current process?
- b. What are the measurement parameters of the current process?
- c. What are the weaknesses of the existing acquisition process?

The current acquisition process at DGSC can be divided into four phases. They are: (1) Perform Procurement Management Activities; (2) Perform Procurement Planning; (3) Solicit, Evaluate, and Award Procurement Instruments; (4) Manage Procurement Instruments (Unisys, 1994:A-7). This information was obtained from an IDEF model prepared by a team of DGSC personnel and contractor consultants. The model is quite in-depth, but with assistance from DGSC contracting personnel the model has been simplified to highlight those tasks that can possibly benefit from re-engineering. The model is also expanded to include the role the contractor plays in the acquisition process (Unisys, 1995:D-22). Figure 4-1 illustrates the simplified model of the current acquisition process at DGSC.

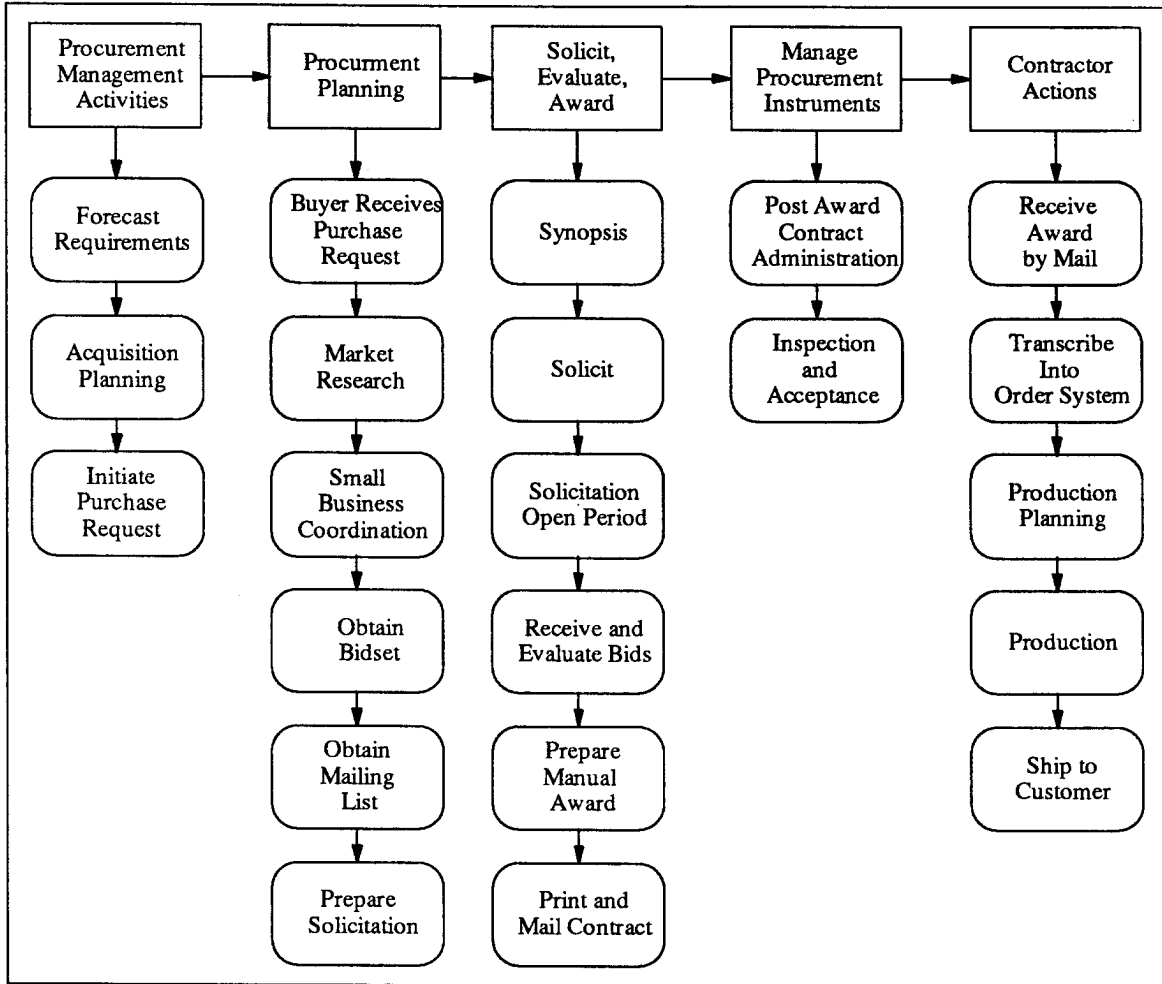

Figure 4.1 Current DGSC Acquisition Process (Unisys, 1995)

Procurement Management Activities as defined by the IDEF model consist of administration of existing laws, regulations, and policies that ensure that a viable contracting organization is in effect. Also, during this time the supply organization is forecasting its requirements and planning acquisitions. It is during this phase that a purchase request (PR) is initiated and sent to procurement. Currently purchase requests are transmitted to the buyer electronically through the DLA Pre-Award Contracting System (DPACS). DPACS is the computerized contracting system used by the DLA

ICPs. This system enables a buyer to generate a solicitation, evaluation, and award documents by manually entering data into the system.

The procurement planning phase as defined by the IDEF model consists of obtaining information and technical data and developing an acquisition plan for the PR. The simplified chart shows that the buyer's job starts with receipt of the PR. The buyer then performs market research to determine what sources are available and if there are any commercial substitutes available. The buyer coordinates with the small business office on whether the acquisition should be set-aside exclusively for bidding by small business. The buyer orders and receives bidsets. A bidset is a complete collection of specifications that are needed to manufacture an item. These are attached to the manual solicitation and are usually in paper or microfiche card format. The buyer obtains a mailing list of potential sources. The buyer prepares the solicitation by manually entering data into DPACS.

The solicitation, evaluation, and award phase as defined by the IDEF model consists of all actions that will result in the award of a contract to satisfy a requirement. The simplified chart shows that this phase begins with synopsis of the solicitation for publication in the Commerce Business Daily (CBD) if it is a large purchase. The solicitation is then mailed to potential bidders. The solicitation is then usually held open for bids for a period of 30 days. Bids are received and opened. The buyer manually enters data into DPACS. Evaluation consists of determining who is the lowest priced responsive and responsible bidder and ensuring that award will be made within the parameters of all applicable procurement laws, regulations, and policies. A paper copy of the contract is printed. Copies are made in the print shop and mailed to the contractor.

Manage procurement instruments as defined by the IDEF model and the simple model consist of post-award contracting functions such as contract clarifications, contract modifications, and waiver requests. Inspection and acceptance is delegated to Defense

Contract Management personnel, although DGSC retains responsibility for ensuring that material is received at the required location.

The contractor receives the contract in the mail; transcribes the data into its order system; plans production; makes a production run; inspects, packages and ships the material to the required destination.

The costs associated with this process are shown in Table 4.1. Costs shown are for Fiscal Year (FY) 1994 for Product Center 1 at the DGSC, which is the product center that procures bellcranks. Annual costs are listed by phase, task area, and task. The table also shows the individual cost a percentage of total cost for each phase, task area, and task. The cost per award made in FY94 is also listed by phase, task area, and task FY94. This chart is meaningful because it shows where acquisition costs are concentrated and where savings may occur if the acquisition process is changed.

The measurement parameters of the current acquisition process are ALT and PLT. Performance measurements for all DGSC procurements for FY94 and FY95 are listed in Table 4.2. Performance measurements for Product Center 1 for FY95 are also provided in the table. Product centers did not exist before FY95. These figures are weighted based on actual number of days and the dollar value of the award.

Table 4.2 Lead-Times at DGSC (McCarty, 1995)

<b>Procurement Center</b>	<b>Period</b>	<b>ALT (Days)</b>	<b>PLT (Days)</b>	<b>Total Lead- Time (Days)</b>
DGSC	FY 94	110	185	295
DGSC	FY 95	103	184	287
Product Center 1	FY 95	145	277	422

Table 4.1 Percentage of Annual Cost and Unit Cost Per Award by Phase, Task Area, and Task for Product Center One (Clarke, 1995)

Action		Costs Per Phase			Cost Per Task Area			Cost Per Task		
Phase/Task Area/Task	FY 94 Cost	% of Total Cost	Cost Per Award	FY 94 Cost	% of Total Cost	Cost Per Award	FY 94 Cost	% of Total Cost	Cost Per Award	
Procurement Management	\$ 160,955	8.38%	\$ 17.40	\$ 160,955	8.38%	\$ 17.40	\$ 160,955.00	8.38%	\$ 17.40	
Procurement Planning	\$ 230,119	11.98%	\$ 24.87							
Customer/Industry Profile				\$ 101,475	5.28%	\$ 10.97				
Refine Customer Requirement							\$ 78,680	4.09%	\$ 8.50	
Market Survey							\$ 5,902	0.31%	\$ 0.64	
Source Selection							\$ 16,893	0.88%	\$ 1.83	
Socio-Economic Requirement				\$ 35,344	1.84%	\$ 3.82	\$ 35,344	1.84%	\$ 3.82	
Develop Procurement Plan				\$ 93,301	4.86%	\$ 10.08	\$ 93,301	4.86%	\$ 10.08	
Solicit, Evaluate, Award	\$ 1,530,313	79.65%	\$ 165.40							
Solicit				\$ 705,562	36.72%	\$ 76.26				
Prepare							\$ 408,792	21.28%	\$ 44.18	
Distribute							\$ 204,083	10.62%	\$ 22.06	
Amend							\$ 92,689	4.82%	\$ 10.02	
Evaluate				\$ 505,725	26.32%	\$ 54.66				
Abstract							\$ 175,982	9.16%	\$ 19.02	
Adherence							\$ 241,344	12.56%	\$ 26.09	
Determine Responsibility							\$ 88,399	4.60%	\$ 9.55	
Award				\$ 319,024	16.60%	\$ 34.48				
Review Award							\$ 124,634	6.49%	\$ 13.47	
Obligate & Sign							\$ 105,904	5.51%	\$ 11.45	
Release Award Data							\$ 56,584	2.94%	\$ 6.12	
Distribute Award							\$ 31,902	1.66%	\$ 3.45	
<b>Total Annual Costs</b>	<b>\$ 1,921,387</b>		<b>\$ 207.67</b>	<b>\$ 1,921,386</b>			<b>\$ 1,921,388</b>			
Total Number of Awards - FY94	9,252									

There are several weaknesses associated with this process. The buyer must manually request a sufficient number of bidsets to send with the solicitation, but it is never really known how many requests for bidsets will be received. The data repository then provides the bidsets in the form of either microfiche cards or paper copies of the drawings required to manufacture the solicited item. The bidsets must be sorted and attached to each solicitation. This is a labor and paper intensive process that can be costly and can add to ALT. With a manually selected mailing list, the pool of potential suppliers is constrained. The buyer also must manually prepare, print and mail the solicitation which adds time to ALT. To ensure that as many interested bidders as possible are able to request, review, and prepare a bid, the solicitation generally remains open for bid for 30 days. The evaluation and award period can add to ALT because it is a manual process and depends on the production level of the buyer. Printing and mailing also add to ALT. The contractor can add to PLT by slowly or incorrectly inputting contract data into the order system. Another source of increased PLT is delayed production due to problems with the TDP. As described above, there are a number of places in the current process that can be changed to decrease ALT and PLT and also yield potential cost savings.

### **Research Question 2**

What alternate methods are available?

The objective of this research is to propose an acquisition process that will improve efficiency, reduce ALT and PLT, and reduce costs to the customer. Review of secondary data and discussions with contracting, technical, and engineering personnel at DGSC, DESC, and OC-ALC reveal that the potential methods for improving the acquisition process can be categorized into three initiatives: electronic commerce, agile manufacturing, and specialized contracting.

Electronic Commerce. EDI and CALS are the two electronic commerce methods that could improve the acquisition process. EDI is computerized, paperless, fast, accurate, and will reach a larger number of contractors. CALS provides quick access to accurate technical data. These methods have the potential to reduce lead-time, reduce personnel and paper costs, and increase the defense industrial base.

Agile Manufacturing. Agile manufacturing is the ability to manufacture small quantities of an item quickly and at a reasonable price (Goldman and others, 1995:3). Methods or initiatives that can enable agile manufacturing are dual use technology, technology transfer, virtual organization, and solid modeling. Dual use technology can simplify the manufacturing process by adopting commercial technology. Technology transfer can improve the manufacturing process by providing a contractor with knowledge that might otherwise be unavailable or too costly to obtain. Forming a virtual organization provides contractors an opportunity to capitalize on someone else's expertise; and encourages cooperation and coordination between partners that can eliminate problems in a process. Solid modeling expands the technical knowledge base and enables exchange of technical knowledge. These methods have the potential to reduce lead-time, reduce material costs, and increase the defense industrial base.

Specialized Contracting. Multiyear, indefinite-delivery, time and materials, and direct vendor delivery, and group buy contracts are all potential methods for improving the acquisition process. Multiyear contracts are used primarily to reduce administrative costs and maintain continuity. IDCs are used when exact requirements are unknown. They also reduce administrative costs and ensure material availability. Time and materials contracts are also used when exact requirements are not known and can ensure material availability. DVD contracts require delivery direct to the customer and are used to reduce inventory levels. A group buy is a single contract for several items of similar style, material, or manufacturing method that allow the contractor to take advantage of

economies of scale and therefore produce a lower price to the government.. These methods have the potential to reduce stock, personnel, and lead-time, and to increase the defense industrial base.

### **Research Question 3**

What is a suitable re-engineered process?

- a. What are the estimated costs associated with the re-engineered process?
- b. What are the estimated measurement parameters of the re-engineered process?

The findings obtained from the first two research questions lead to the proposed acquisition process illustrated in figure 4-2. This figure illustrates the hypothesis that the current acquisition process can be improved by incorporating electronic commerce, agile manufacturing, and specialized contracting initiatives. The EC and specialized contracting initiatives are incorporated into the solicitation and award process. EC and agile manufacturing initiatives are incorporated into the contractor actions process. These initiatives were selected based on review of secondary data and interviews with knowledgeable personnel.

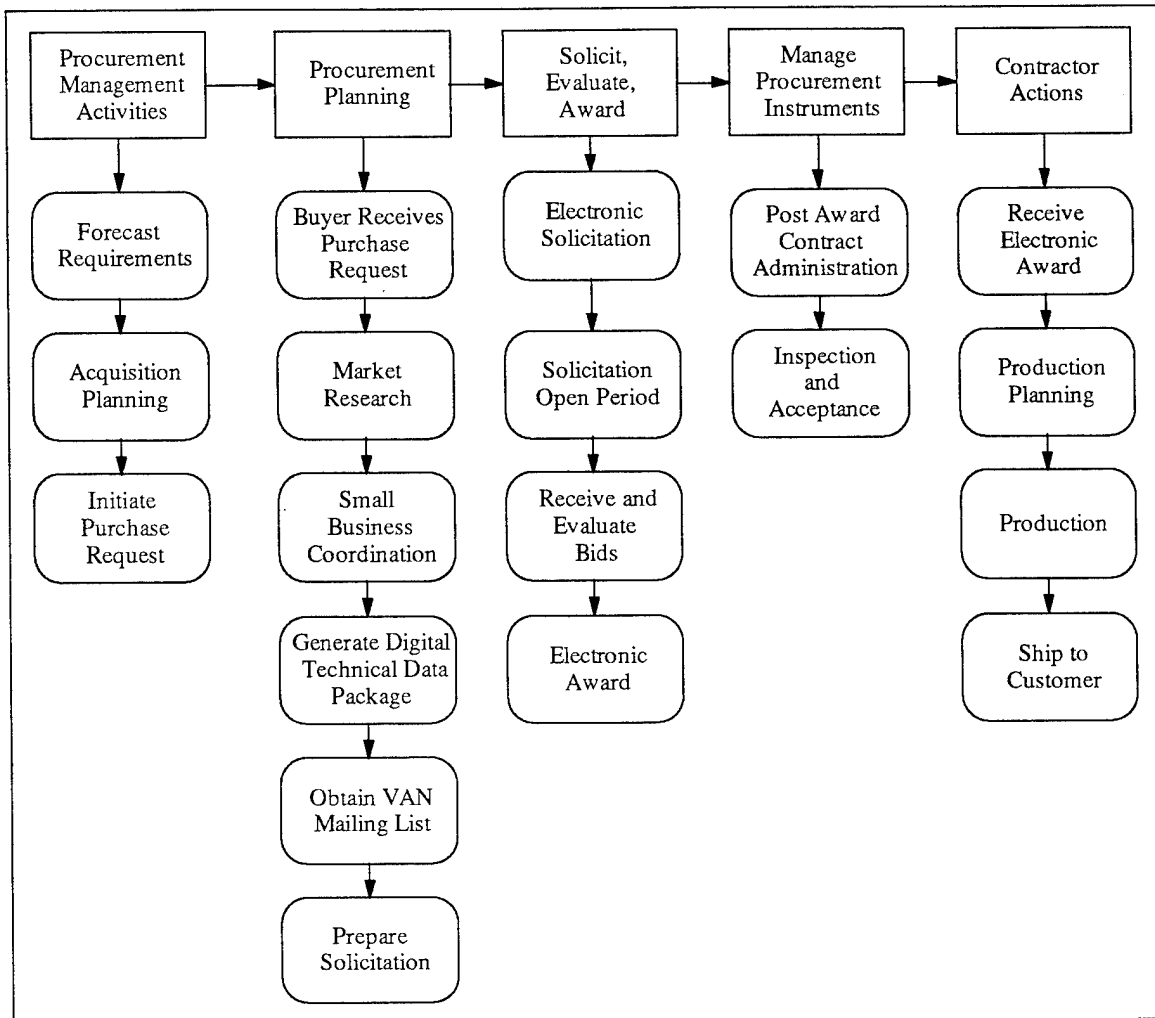

Figure 4.2 Proposed Acquisition Process

Because the functional requirements of the acquisition process have not changed, it appears at first glance that the two processes are not significantly different. In fact there are no changes in the Procurement Management Activities and Manage Procurement Instruments phases. However, the methods of performing the functional requirements have changed in the other phases. These changes stem from the implementation of electronic commerce, agile manufacturing, and specialized contracting methods. These changes are described further in the following paragraphs.

Electronic Solicitation. In the Procurement Planning phase the buyer must still perform market research. However, this process is made easier because electronic solicitation will ensure a larger pool of potential suppliers. Digital technical data packages will be available and can be transmitted electronically with each solicitation. No small business coordination will be required because FACNET ensures set-aside for small business all acquisitions between \$2,500 and the new simplified purchase threshold of \$100,000. This will reduce the amount of paper that must be handled with manual technical data packages. Solicitations will be transmitted electronically to VANs which will retransmit them to businesses that have expressed an interest in bidding on the solicited commodity type. This will provide a wider range of potential sources. Electronic solicitation will reduce ALT in several ways. First, the solicitation will reach its destination instantaneously. The solicitation open period can be reduced. Bids will be input automatically into the DPACS database and the computer will highlight the best bid in accordance with the prearranged criteria, subject to buyer approval. Finally the award will not have to be printed and mailed. PLT will be reduced because the contractor will receive the award almost instantaneously. Also there is no possibility that the contract data will be input incorrectly into the contractor's order system.

Agile Manufacturing. Another method of decreasing PLT involves improving the agility of the contractor's production process by providing technical assistance. Technology transfer can improve the manufacturing process by providing a contractor with knowledge that might otherwise be unavailable or too costly to obtain. Solid modeling is one format for enabling transfer of technical knowledge. Forming a virtual organization is another way of increasing agility by providing contractors an opportunity to capitalize on someone else's expertise. Bellcranks can be used to illustrate agile manufacturing. DGSC can provide an electronically transmitted knowledge base or solid model for a particular item or an electronically transmitted CNC program tape that will run on the

contractor's machine. The contractor receives information he would not otherwise have, and can use that knowledge to improve his production lead-time.

Specialized Contracting Methods. Another method of decreasing PLT involves specialized contracting. DGSC can identify items with similar manufacturing methods such as the bellcranks and then can issue a multiyear indefinite quantity type contract in anticipation of future requirements. This will reduce ALT when a requirement is received because the acquisition process need not be repeated. An electronic delivery order can be transmitted upon confirmation of the requirement. PLT can be reduced because the contractor will give greater emphasis to orders for a contract where his performance is evaluated before the government will exercise its annual option to renew the contract.

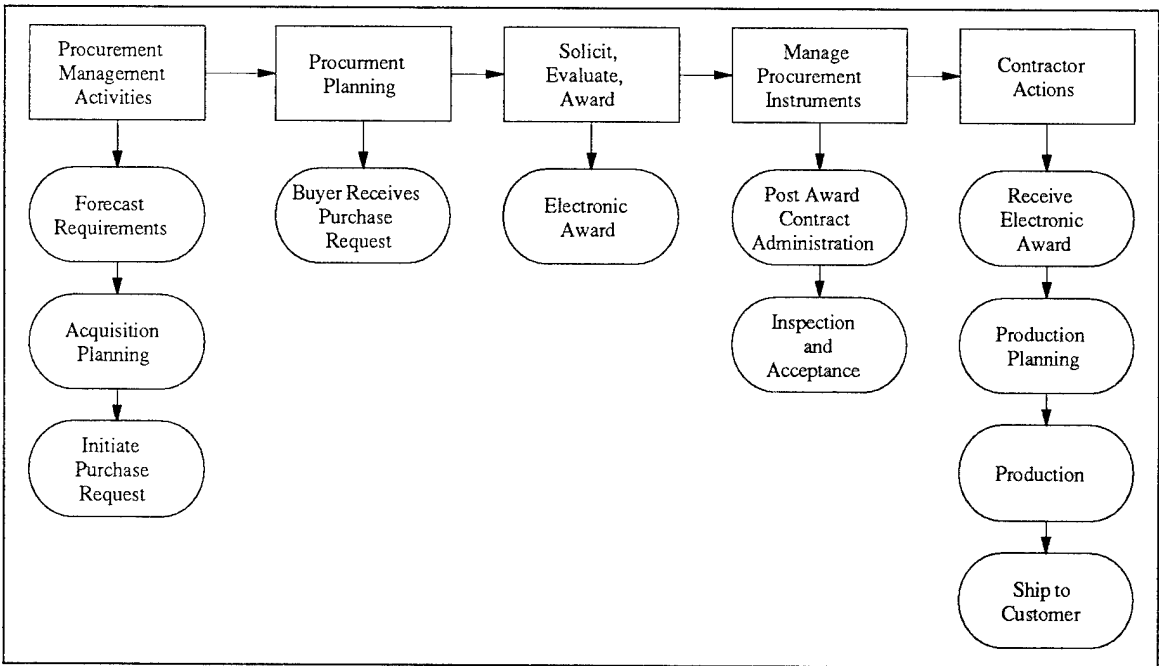

Figure 4.3 Multiyear Contract Delivery Order Process

Another potential contracting method is to issue a time and materials contract. In advance the government and the contractor will agree on a price to be paid for the actual

time and materials the contractor puts into each delivery order. The advantage to this type of contracting is that a wider range of items can be placed on one contract without the burden of having to negotiate prices for each item. This will reduce the ALT of the long-term contract process.

#### **Research Question 4**

How do costs and benefits of the proposed re-engineered process compare with those of the existing process? Research question 3 details three initiatives for changing the acquisition process. Figure 4.4 shows the tasks that are most affected by the incorporation of electronic commerce, agile manufacturing, and specialized contracting into the proposed process. These affected tasks are known as the relevant factors and can be used to compare the costs and benefits of the two processes outlined in figures 4.1 and 4.2.

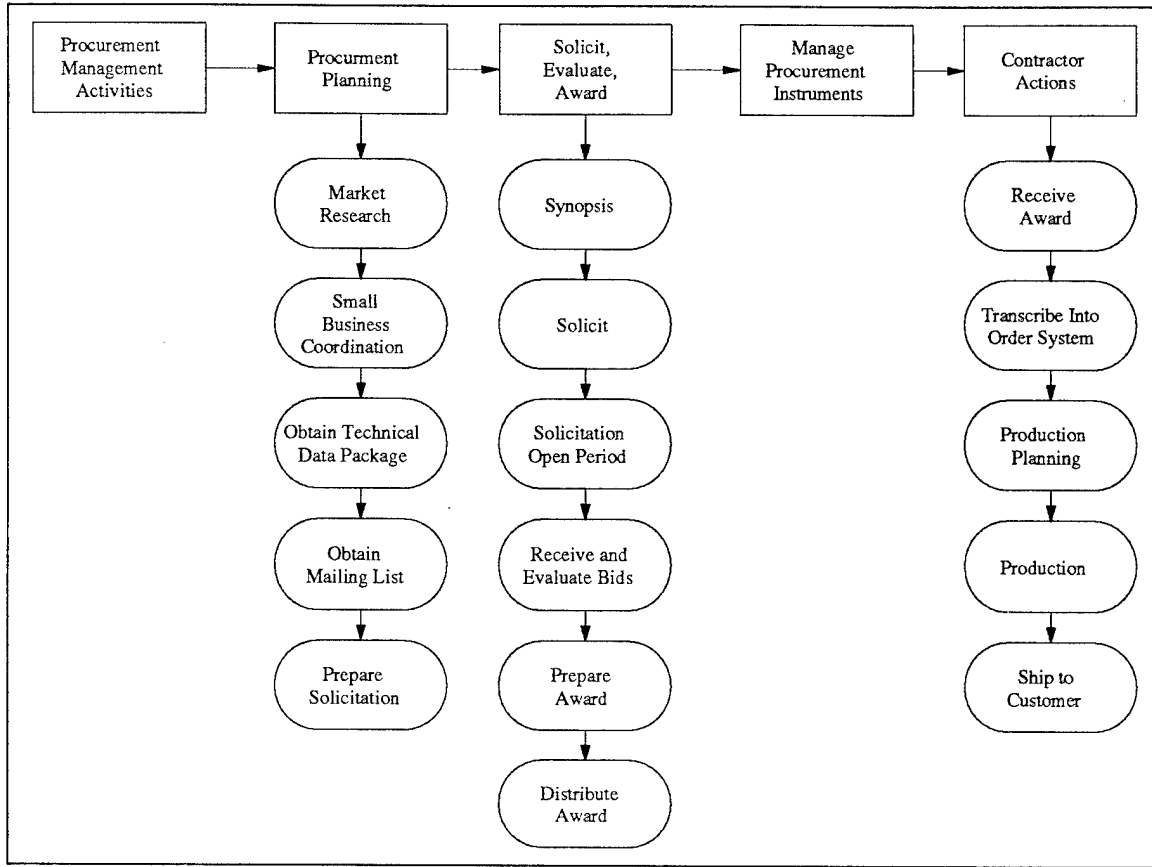

Figure 4.4 Relevant Factors

An exact comparison of relevant measurements cannot be made for several reasons. First, DGSC does not break out costs for every task, therefore data for some tasks in the proposed process were not available. Second, DGSC does not break out its ALT and PLT measurements by task. Third, previous research studies did not provide enough data to permit an accurate estimate of costs and lead-time for the proposed process. Table 4.3 lists each of these relevant factors along with per unit cost, percentage of total costs and whether costs and lead-time will be affected by the change.

Table 4.3 Cost and Benefit Analysis of Relevant Factors

Relevant Factor	Current Unit Cost	Current % of Total Cost	Re-engineered Cost	Re-engineered Lead-Time
<b>Procurement Management</b>	N/M	N/M	N/M	N/M
<b>Procurement Planning</b>				
Market Research	\$ 0.64	0.30%	MR	MR
Socio-Economic Requirement	\$ 3.82	1.84%	SR	SR
Obtain Bidset/TDP	N/A	N/A	SR	SR
Obtain Mail List	N/A	N/A	U	U
Prepare Solicitation	\$ 44.18	21.28%	SR	SR
<b>Solicit, Evaluate, Award</b>				
Synopsis	N/A	N/A	MR	SR
Solicit	\$ 22.06	10.62%	SR	SR
Open Period	N/M	N/M	U	SR
Receive & Evaluate Bid	\$ 54.66	26.32%	SR	SR
Prepare Award	\$ 11.45	6.49%	SR	SR
Distribute Award	\$ 3.45	1.66%	SR	SR
<b>Manage Procurement Inst.</b>	N/M	N/M	N/M	N/M
<b>Contractor Actions</b>				
Receive Award	N/A	N/A	N/M	SR
Transcribe Award	N/A	N/A	N/M	U
Production Planning	N/A	N/A	PI	SR
Production	N/A	N/A	U	U
Ship to Customer	N/A	N/A	N/M	N/M
Legend: SR - Significant Reduction				
MR - Minor Reduction				
U - Unknown				
N/A - Not Available				
N/M - Not Meaningful				

Table 4.3 indicates that significant cost and lead-time savings should occur as a result of the re-engineered process. Preparing the solicitation, soliciting, and evaluating the bids account for 66 percent of acquisition costs which is about \$1.268 million. Most of the savings would be a result of the implementation of electronic commerce.

Lead-time should also be reduced significantly as a result of electronic commerce. Lead-time will be saved by eliminating mail delivery in the solicitation and award stages. Significant lead-time reductions should also occur as a result of technology transfer and agile manufacturing. OC-ALC has shown that significant lead-time reductions can occur (DoDa, 1994). However, an increased cost may occur as a result of building a solid model

design and creating a CNC program. Estimated cost of an average bellcrank is \$1800.00 for designing a model and \$360.00 for creating a CNC program (see table 4.4). However these would be non-recurring costs that could be offset by lower prices for items that have recurring demands and require future acquisition. Development time may also decrease as additional common methods are identified and programmed.

Table 4.4 Technology Transfer Costs (Kincaid, 1995)

Function	Hours	Rate	Total Cost
Solid Model Design	24	\$ 75.00	\$ 1,800.00
CNC Program Creation	8	\$ 45.00	\$ 360.00
<b>Total Cost Per Bellcrank</b>			\$ 2,160.00

Multiyear contracts and DVD contracts should produce a reduction in lead-time. Savings should also occur as a result of contracting initiatives. Statistics obtained from DLA (Table 4.5) show that the logistics response time from receipt of the requisition at the depot until the item is shipped to the customer is significantly less for planned DVD items than unplanned DVD and non-stocked items. Planned DVD items are usually multiyear indefinite quantity contracts. Unplanned DVD contracts are usually for stocked items that are temporarily out of stock.

Table 4.5 Logistics Response Time (James, 1995)

Type Of Item	Logistics Response Time
Stocked	47 Days
Planned DVD	61 Days
Unplanned DVD	132 Days
Non-Stocked	225 Days

There are several advantages to awarding a contract that purchases only time and material instead of setting a negotiated price for certain part numbers. First, the ICP could issue a contract that might cover any item with pre-identified manufacturing methods.

This would provide greater flexibility in ordering and reduce ALT and PLT. Second, more contractors may be interested in bidding on a contract if they are assured of a definite amount of business. One disadvantage of this type contract is that it requires greater government surveillance of the contractor. It is costly as well as being one of the practices that FASA is trying to reduce. However, if estimated labor and material standards could be placed in the delivery order, than the contractor would be able to recognize a problem if their estimate is different. Another drawback is that the FAR does not permit the use of time and material contracts unless no other contract will do. This is a concept that requires further study.

Finally, data for the potential group buy data as proposed by OC-ALC is found in table 4.6. The table illustrates that lead-time for these items is slightly higher than for average Product Center 1 items, almost double the lead-times than for the average item at DGSC. Based on lead-time they appear to be good candidates for group buy, but demand may not be sufficient to attract interest. However, if 50, 100, or more of these similar items were identified and awarded on one contract, contractors may take show greater interest in bidding.

Table 4.6 Bellcrank Group Data (SAMMS)

NSN	Stocked Item	Current Inventory	ALT	PLT	Total Lead Time	Last Buy
1560-01-173-3287	Nominal Amount	9	172	228	400	Feb-91
1560-01-174-1688	Nominal Amount	0	172	365	537	Oct-82
1560-01-174-4865	Yes	4	172	365	537	Oct-82
1560-01-203-7321	Yes	4	172	365	537	Oct-82
1560-01-299-2618	Nominal Amount	3	172	365	537	Oct-82
1680-01-369-7018	Nominal Amount	0	150	320	470	Jun-95

## **Summary**

This chapter reported the findings obtained from the case study research. It provided findings for each of the research questions. The current acquisition process was illustrated. Potential improvement methods were suggested. A re-engineered acquisition was proposed. Finally the re-engineered process was evaluated. Conclusions and recommendations are presented in the next chapter.

## **V. Conclusions and Recommendations**

### **Chapter Overview**

This chapter presents the conclusions and recommendations of this research. The conclusions reached are based on data from the literature review and case study findings. Because this is an exploratory case study and the purpose is to develop hypotheses and research questions for future study, recommendations for future research are made. This chapter ends with a summary of the entire thesis.

### **Conclusions**

The primary objective of this research was to determine if there was support for further research into re-engineering the acquisition process of non-stocked, buy on demand, spare parts. Based on the findings presented in Chapter IV, several conclusions were reached. General conclusions are presented first, followed by conclusions for each of the three major initiatives.

**General Conclusions.** This study was unable to isolate and quantify particular lead-time problems with the current acquisition process because DGSC does not break out lead-time by task, purchase size, or award method. Also there was not a sufficient amount of literature to provide a basis for accurate estimation of lead-times for the re-engineered process. Therefore, lead-time could not be quantitatively evaluated. Although inconclusive, what data is available seems to indicate that lead-time could be reduced significantly by using the proposed acquisition process.

Although DGSC does break out contracting costs by task, findings pertaining to cost reduction as a result of the proposed acquisition process were also inconclusive. A quantitative cost comparison could not be made because there was an insufficient amount of literature to provide a basis for accurate estimation of costs for the proposed process.

Although inconclusive, research findings in the previous chapter seem to indicate that procurement costs could be reduced significantly by using the proposed acquisition process.

Electronic Commerce Conclusions. Conclusions can be drawn for the effect that using electronic commerce will have on each of the problem areas cited in the problem statement section of chapter I. Stock levels should be reduced because EC decreases ALT and therefore reduces the economic ordering quantity and the amount of safety stock required. EC should reduce the labor intensiveness of the current process and therefore provide a significant reduction in contract processing costs as well as providing a significant reduction in lead-time. EC should also increase the defense industrial base because solicitations will be available to a larger pool of sources. The contract price may decrease because competition should be intensified by the larger pool of sources, however prices may increase if purchases are made more frequently in small quantities.

Agile Manufacturing Conclusions. Conclusions can be drawn for the impact of agile manufacturing on each of the problem areas cited in the problem statement section of chapter I. Agile manufacturing could decrease stock levels because PLT could be reduced through transfer of technology such as CNC programs, especially if IDC and DVD contracts are used. Agile manufacturing has no effect on the labor intensity of the acquisition process. It is anticipated that the defense industrial base will increase by many small businesses through technology transfer and through the virtual organization where larger or more experienced defense contractors partner with the government and academia to provide assistance to small business. The contract price may decrease because competition should be intensified by the larger pool of sources. Also, using IDC contracts may lead to lower prices. Items purchased in small quantities for DVD may increase in price.

The research raises two negative aspects of agile manufacturing. First, the research does not conclusively indicate that agile manufacturing will be both cost effective as well as beneficial in reducing lead-times. The solid modeling concept appears to be beneficial when modeler and manufacturer both have the same computer system, but may not work quite as well if the two parties have different systems. Also, providing CNC programs directly to manufacturers may not be effective, because computerized machining machines can be very sensitive to even the slightest program errors and could cause the machine to shut down. Many contractors may prefer to create their own programs to preclude this problem. Second, the initial cost of building a knowledge base for an item may be greater than the benefit derived if the item is purchased infrequently in small quantities.

Contracting Conclusions. Conclusions can be drawn for the effect that specialized contracting techniques will have on each of the problem areas cited in the problem statement section of chapter I. First, inventory can be reduced by using multiyear, IDC and DVD contracts. Second, labor intensity can be reduced by using IDC contracts because delivery orders require do not require that the competitive acquisition process be repeated. Because many contracting tasks can be eliminated, contracting costs and ALT are reduced. Third, the defense industrial base may increase because IDC and multiyear contracts may be for a large enough dollar amount to provide an incentive to contractors that normally would not bid. Finally, contract prices can be reduced by using IDC and multiyear contracts because the contractor will realize certain economies of scale such as lower prices for larger quantities of material.

Time and materials contracts have the potential to decrease inventory, decrease lead-time, and increase the defense industrial base. They also can reduce contract price by allowing the contractor to purchase larger quantities of common material such as aluminum for bellcranks at a lower price. Also, costs may be saved if the actual time and

material is less than what was estimated, because a negotiated fixed price would likely be based on the estimate. On the negative side, costs could increase if the actual time and material is greater than what was estimated. Another problem is that surveillance costs may be too high because the contractor would be required to submit invoices and time sheets for review by the government. Because the FAR states that a time and materials contract should be the contract of last resort, a waiver would be required from the Office of the Secretary of Defense (OSD) to proceed with this concept on an experimental basis.

### **Recommendations**

Embrace Electronic Commerce. DoD has already committed to fully implementing electronic commerce by January 1997. DGSC should attempt to identify areas of the process that could further be improved. This can be accomplished by stratifying ALT and PLT for each acquisition task.

Continue Agile Manufacturing Initiatives. OC-ALC should continue with its agile manufacturing, virtual organization, and group buy initiatives. It appears that these ideas have potential for significantly improving the acquisition process. However, OC-ALC needs to begin methodical tracking of the costs and benefits resulting from this process. OC-ALC should also attempt to quantify the cost of inoperable equipment due to a lack of spare parts whenever possible. If that is not possible, then OC-ALC should attempt to qualify the impact that the inoperable equipment will have on the DoD's mission. Data could then be compared to determine if added costs of technical transfer are exceeded by the benefits obtained.

Test Specialized Contracting Methods. DGSC should proceed with the multiyear, IDC, and DVD contracting initiatives because there is potential for significant procurement cost and inventory reduction. DGSC and OC-ALC should continue to pursue the idea to contract for time and materials only. At least one time and materials

contract should be awarded in order to determine if more flexibility exists than with fixed-price contracts. A waiver to use time and materials contracts should be sought from the appropriate approval source within OSD.

### Summary

The purpose of this research was to explore potential alternatives to the current DoD acquisition process for low demand, high dollar value, not commercially stocked, spare parts because of decreased defense spending. It was anticipated that these alternatives would improve the acquisition process and would reduce acquisition costs, reduce lead-time, and increase the defense industrial base. Chapter I introduced the problem with the acquisition process at the Defense General Supply Center. Demand for certain items is insufficient to justify maintaining stock, while the buy on-demand alternative results in long lead-times and increased costs due to the labor intensiveness of the current process, lack of willing manufacturing sources, and higher prices paid for small quantities of material.

The case study method was determined to be the best research method for exploring this problem. A secondary data review and interviews with personnel at DGSC and OC-ALC were used to discover and evaluate potential changes to the current acquisition process. This review resulted in a hypothesized potential acquisition process that incorporated methods involving electronic commerce, agile manufacturing, and specialized contracting initiatives. Data gathered from secondary data review and from interviews was used to compare and evaluate the costs and benefits of both processes. This evaluation lead to the conclusion that although quantifiable data is incomplete, electronic commerce, agile manufacturing, and unique contracting initiatives all have potential for significantly improving the acquisition process.

Recommendations were made for DGSC to adopt EC and continue to seek ways to use EC to improve the acquisition process; OC-ALC to continue with the agile manufacturing project and to attempt to quantify costs and benefits; and for DGSC and OC-ALC to work together to use specialized contracting methods and to pursue an experimental contract for machine time and materials.

The findings of this study are inconclusive and do not prove that the hypothesized re-engineered acquisition process is quantifiably better than the current acquisition process. However, this research is important because of its attempt to evaluate the effects of multiple initiatives upon the acquisition process. The findings and conclusions of this study indicate that significant improvement in the acquisition process will probably occur as a result of the hypothesized changes. Therefore, this study provides the basis for justifying further research into re-engineering the acquisition process.

## **Appendix A. List of Interview Questions**

1. What do you see as the current acquisition process?
2. What do you think are the weaknesses in the current acquisition process?
3. What are the strengths in the current acquisition process?
4. What can be done differently to improve the acquisition process?

## **Appendix B. List of Acronyms**

ALT	Administrative Lead-Time
BPR	Business Process Re-engineering
CAD	Computer Aided Design
CALS	Continuous Acquisition and Life Cycle Support
CBD	Commerce Business Daily
CNC	Computer Numerical Control
DESC	Defense Electronics Supply Center
DGSC	Defense General Supply Center
DLA	Defense Logistics Agency
DoD	Department of Defense
DPACS	DLA Pre Award Contracting System
DVD	Direct Vendor Delivery
EC	Electronic Commerce
ECRC	Electronic Commerce Resource Center
EDI	Electronic Data Interchange
FACNET	Federal Acquisition Computer Network
FAR	Federal Acquisition Regulation
FSC	Federal Supply Class
FY	Fiscal Year
GAO	Government Accounting Office
ICP	Inventory Control Point
IDEF	Integrated Definition Language
JIT	Just In Time
LI	OC-ALC Manufacturing Branch

NSN	National Stock Number
OC-ALC	Oklahoma City Air Logistics Center
OSD	Office of the Secretary of Defense
PLT	Production Lead-Time
RFQ	Request for Quotation
TDP	Technical Data Package
TI	OC-ALC Technical Insertion Branch
VAN	Value Added Network
WSEC	Weapons System Essentiality Code

## References

- Anderson, Robert H. and Judith E. Payne. Electronic Data Interchange (EDI): Using Electronic Commerce to Enhance Defense Logistics. Contract MDA903-90-C-0004. Santa Monica CA: RAND National Defense Research Institute, 1991 (RAND/R-4030-P&L).
- Arnavas, Donald P. and William J. Ruberry. Government Contract Guidebook. Washington: Federal Publications Inc., 1994.
- Arunachalam, Vairam. "EDI: An Analysis of Adoption, Uses, Benefits and Barriers." Journal of Systems Management, 46: 60-65 (March/April 1995).
- Banerjee, Snehamay and Damodar Y. Golhar. "EDI Implementation: A Comparative Study of JIT and Non-JIT Manufacturing Firms," International Journal of Physical Distribution & Logistics, 7: 22-31 (1993).
- Bowlds, Ted F. Maintaining the Defense Industrial Base. Research report, unnumbered. Air War College, Maxwell AFB AL, May 1994 (AD-A280548).
- Breen, Gregory F. The Feasibility of Long-Term Contracting In the Department of Defense. MS thesis. Naval Postgraduate School, Monterey CA June 1993 (AD-A271718).
- Byrne, John A. "The Virtual Corporation," Business Week: 98-103 (February 8, 1993).
- Carr, David K. and Henry J. Johansson. Best Practices in Reengineering: What Works and What Doesn't in the Reengineering Process. New York: McGraw-Hill Inc., 1995.
- Chmielewski, Irvin. United Nations Rapporteur for the Pan American EDIFACT Region. "Electronic Commerce GM/EDS Partnership. Address to the Electronic Commerce Conference sponsored by the Society of Logistics Engineers. Dayton OH, 4 May 1995.
- Clarke, Alan R. Management Engineer, Management Engineering Office, Defense General Supply Center, Richmond VA. Telephone Interview, 20 November 1995.

Clinton, William J. "Memorandum on Streamlining Procurement Through Electronic Commerce," Weekly Compilation of Presidential Documents, 29: 2175 (November 1993).

Computer-Aided Technology Transfer (CATT) DLA Project - Phase I/Task Team #1 Process Characterization & Model Definition. Subcontract OK01-95-TMR-0004. McClean VA: Unisys Corporation, Government Systems Group - Federal Systems, 1 May 1995.

Continuous Acquisition and Life-Cycle Support (CAL S) Orientation. Training Presentation Manual. Dayton: The Dayton Electronic Resource Center, 1995.

Cooper, Donald R. and C. William Emory. Business Research Methods. Chicago: Richard D. Irwin Inc., 1994.

Department of Defense. Computer-Assisted Technology Transfer (CATT). Unpublished Report, September 1994.

Department of Defense. Defense Performance Review: Best Value Common Supplies and Services. Public Report. Washington: Government Printing Office, 1993.

Department of Defense. Defense Science and Technology Strategy. Public Report. Washington: Government Printing Office, September 1994.

Department of Defense. DoD Electronic Commerce (EC)/Electronic Data Interchange (EDI) in Contracting Report. Washington: 1994.

Department of Defense. Dual Use Technology: A Defense Strategy for Affordable, Leading-Edge Technology. Washington: February 1995.

Department of Defense. DoD Implementation Guidelines for Electronic Data Interchange (EDI), Volume 1. Contract MDA903-90-C-0006. Bethesda MD: Logistics Management Institute, December 1991.

"DoD Urged to Work for Single EDI Standard," Federal Contracts Report, 64: 324 (16 October 1995).

Emmelhainz, Margaret A. Electronic Data Interchange. A Total Management Guide. New York: Van Nostrand Reinhold, 1990.

Federal Acquisition Regulation. Washington: 15 December 1994.

- Gansler, Jacques S. "Restructuring the Defense Industrial Base," Issues in Science and Technology, 8: 50-58 (Spring 1992).
- General Accounting Office. Inventory Management: DoD Can Build on Progress in Using Best Practices to Achieve Substantial Savings. Report Number NSIAD-94-142. Washington: Government Printing Office, 1995.
- Goldman, Steven L. and others. Agile Competitors and Virtual Organizations: Strategies for Enriching the Customer. New York: Van Nostrand Reinhold, 1995.
- Gutmanis, Ivars. "The Future of the Defense-Related Industrial Base in the United States," Parameters, 24: 61-76 (Summer 1994).
- Heberling, Michael A. "Defense Industrial Base Policy: Revisited," Acquisition Review Quarterly, 1: 238-249 (Summer 1994).
- Horngren, Charles T., George Foster, and Srikant M. Datar. Cost Accounting: A Managerial Emphasis. Englewood Cliffs NJ: Prentice Hall, 1994.
- Hunt, V. Daniel. Enterprise Integration Sourcebook: The Integration of CALS, CE, TQM, PDES, RAMP, and DIM. San Diego: Academic Press Inc., 1991.
- I-DEAS Masters Series. Product Catalog. Milford OH: Structural Dynamics Research Corporation, March 1993.
- James, Robert. Supervisory Supply Systems Analyst, Defense Electronics SupplyCenter, Dayton OH. Personal Interview. 22 November 1995.
- Johnson, Joyce. Supply Systems Analyst, Defense General Supply Center, Richmond VA. Telephone Interview. 22 November 1995.
- Kincaid, Edwin. Chief, Technical Insertion Branch, Oklahoma City Air Logistics Center, Tinker AFB OK. Telephone Interview. 13 November 1995.
- Lamb, Dr. Neil. "An Overview of the Federal Government's Electronic Commerce Acquisition Program," Contract Management, 35: 17-20 (December 1995).
- Litman, Elaine. Department of Defense Director, CALS and EDI. "The CALS Initiative." Address to the Electronic Commerce Conference sponsored by the Society of Logistics Engineers. Dayton OH, 4 May 1995.

- Luster, Steven and Richard Modrowski. DoD Electronic Data Interchange (EDI) Convention: ASC X12 Transaction Set 841 Specifications/Technical Information (Solicitation Technical Documentation) (Version 003030). Contract MDA903-90-C-0006. Bethesda MD: Logistics Management Institute, 1993.
- McCarty, Patricia. Supply Systems Analyst, Defense General Supply Center, Richmond VA. Telephone Interview. 21 November 1995.
- Nagel, Roger A. 21st Century Manufacturing Enterprise Strategy Report. Contract N00014-91-C-0150. Iacocca Institute, Lehigh University, 1992 (AD-A257032).
- Preston, Colleen. Deputy Undersecretary of Defense for Acquisition Reform. "DoD Must Re-Engineer Its Procurement System Now." Speech to the House Government Reform and Oversight Committee. Washington, 21 February 1995.
- Rosener, Kirk. Electronic Commerce and the NII. Unpublished Report. CALS Shared Resource Center, Dayton OH, 1994.
- Terino, John G. "Program Wagers on Dual Use to Bring Down Costs," National DEFENSE, 78: 39-40 (January 1994).
- Widnall, Sheila E. Secretary of the Air Force. "The Choice and the Opportunity Are Ours." Address to the National Security Forum. Maxwell Air Force Base AL 8 June 1995.
- Yin, Robert K. Case Study Research: Design and Methods. Newbury Park CA: Sage Publications Inc., 1989.

### Vita

Mark E. Koesters was born in Dayton, OH on April 4, 1955. He graduated from Wilbur Wright High School in Dayton, OH in June 1973. He enlisted in the Air Force in September of that year and served for four years. He received a Bachelor of Science in Business Administration from the University of Dayton in December 1980. He went to work for the Department of Defense in September 1982 at the Defense Electronic Supply Center in Dayton, OH where he performed a variety of jobs in the contracting field. He worked as a post award contract specialist, contract price analyst, and as a contract negotiator, and contracting officer. He is currently a Supply Systems analyst who works with customers to forecast their requirements. Mr. Koesters is married and has a son.

Permanent Address: 2033 Fauver Avenue  
Dayton, OH 45420

# REPORT DOCUMENTATION PAGE

Form Approved  
OMB No. 0704-0188

Public reporting burden for this collection of information is estimated to average 1 hour per response, including the time for reviewing instructions, searching existing data sources, gathering and maintaining the data needed, and completing and reviewing the collection of information. Send comments regarding this burden estimate or any other aspect of this collection of information, including suggestions for reducing this burden, to Washington Headquarters Services, Directorate for Information Operations and Reports, 1215 Jefferson Davis Highway, Suite 1204, Arlington, VA 22202-4302, and to the Office of Management and Budget, Paperwork Reduction Project (0704-0188), Washington, DC 20503.

<b>1. AGENCY USE ONLY (Leave blank)</b>	<b>2. REPORT DATE</b> December 1995	<b>3. REPORT TYPE AND DATES COVERED</b> Master's Thesis
---	--	--

<b>4. TITLE AND SUBTITLE</b> RE-ENGINEERING THE ACQUISITION PROCESS OF MANUFACTURED ON-DEMAND ONLY SPARES	<b>5. FUNDING NUMBERS</b>
---	---------------------------

<b>6. AUTHOR(S)</b>  Mark E. Koesters, GS-11	
--	--

<b>7. PERFORMING ORGANIZATION NAME(S) AND ADDRESS(ES)</b>  Air Force Institute of Technology, WPAFB OH 45433-7765	<b>8. PERFORMING ORGANIZATION REPORT NUMBER</b>  AFTT/GLM/LAL/95S-11
--	--

<b>9. SPONSORING / MONITORING AGENCY NAME(S) AND ADDRESS(ES)</b>  HQ USAF/LGMM Washington DC 20330	<b>10. SPONSORING / MONITORING AGENCY REPORT NUMBER</b>
---	---

<b>11. SUPPLEMENTARY NOTES</b>
--------------------------------

<b>12a. DISTRIBUTION / AVAILABILITY STATEMENT</b>  Approved for public release; distribution unlimited	<b>12b. DISTRIBUTION CODE</b>
--	-------------------------------

<b>13. ABSTRACT (Maximum 200 words)</b>  The purpose of this study is to explore potential alternatives to the current Department of Defense (DoD) acquisition process for low demand, high dollar value, not commercially stocked, spare parts in order to better utilize diminishing resources, reduce cycle costs, and sustain the defense industrial base. Demand for these items is insufficient to justify maintaining inventory, while the buy on-demand alternative results in long lead-times and increased costs due to the labor intensiveness of the current process, lack of willing manufacturing sources, and higher prices paid for small quantities of material. An exploratory case study method was used to study the Defense General Supply Center's (DGSC') acquisition process. Data gathered from secondary data review and from interviews with contracting and technical personnel was used to define the current process, hypothesize a better process, and to evaluate the costs and benefits of both processes. This evaluation lead to the conclusion that electronic commerce, agile manufacturing, and specialized contracting initiatives all have significant potential for improving the acquisition process. Recommendations were made for DGSC to continue research into using electronic commerce, agile manufacturing, and specialized contracting methods to improve the acquisition process
---

<b>14. SUBJECT TERMS</b>	<b>15. NUMBER OF PAGES</b> 74
--------------------------	----------------------------------

Electronic Data Interchange, Business Process Reengineering, Contracts, Logistics, Electronic Commerce	<b>16. PRICE CODE</b>
--	-----------------------

<b>17. SECURITY CLASSIFICATION OF REPORT</b> Unclassified	<b>18. SECURITY CLASSIFICATION OF THIS PAGE</b> Unclassified	<b>19. SECURITY CLASSIFICATION OF ABSTRACT</b> Unclassified	<b>20. LIMITATION OF ABSTRACT</b> UL
--	---	--	---