

The US Army's Center for Strategy and Force Evaluation

STUDY REPORT
CAA-SR-92-2

**ATTRITION CALIBRATION (ATCAL)
EVALUATION PHASE II - INDIRECT FIRE
(ATVAL PHASE II)**

FEBRUARY 1992

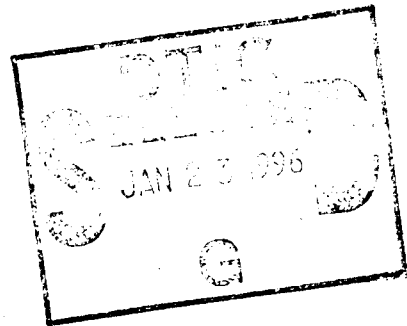

DTIC QUALITY INSPECTED *

19960105 064

PREPARED BY
FORCE EVALUATION DIRECTORATE

US ARMY CONCEPTS ANALYSIS AGENCY
8120 WOODMONT AVENUE
BETHESDA, MARYLAND 20814-2797

DTIC QUALITY INSPECTED 1

DTIC
Accession
Number



CONCEPTS ANALYSIS AGENCY

DISCLAIMER

The findings of this report are not to be construed as an official Department of the Army position, policy, or decision unless so designated by other official documentation. Comments or suggestions should be addressed to:

**Director
US Army Concepts Analysis Agency
ATTN: CSCA-FE
8120 Woodmont Avenue
Bethesda, MD 20814-2797**

STUDY REPORT
CAA-SR-92-2

ATTRITION CALIBRATION (ATCAL) EVALUATION PHASE II - INDIRECT FIRE
(ATVAL PHASE II)

February 1992

Accession For	
NTIS CRA&I	<input checked="" type="checkbox"/>
DTIC TAB	<input type="checkbox"/>
Unannounced	<input type="checkbox"/>
Justification	
By	
Distribution /	
Availability Codes	
Dist	Avail and/or Special
A-1	

Prepared by

FORCE EVALUATION DIRECTORATE
Mr. Neal W. Siegel, Study Director

US Army Concepts Analysis Agency
8120 Woodmont Avenue
Bethesda, Maryland 20814-2797

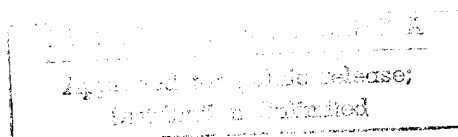

This document was prepared as part of an internal CAA project.



**ATTRITION CALIBRATION (ATCAL)
EVALUATION PHASE II -
INDIRECT FIRE (ATVAL PHASE II)**

**STUDY
SUMMARY
CAA-SR-92-2**

THE REASON FOR PERFORMING THE STUDY is to learn more about the indirect fire algorithms in the Attrition Calibration (ATCAL) process. Specifically, the question to answer is how well does ATCAL extrapolate indirect fire using calibrated parameters to compute attrition and rounds fired in theater models. The ATCAL model is the linkage between high-resolution, tactical level and low-resolution, theater-level modeling.

THE STUDY SPONSOR is the Director, US Army Concepts Analysis Agency (CAA).

THE STUDY OBJECTIVES are to:

- (1) Examine indirect fire logic in ATCAL.
- (2) Provide observations on how well the indirect fire logic performs.

THE SCOPE OF THE STUDY includes two main focuses, both of which center around artillery issues. The first is research oriented and involves examining other models, recording historical trends and interviewing experts. Data results from this phase will be compared to artillery results generated by using the ATCAL process. The second focus is analytically oriented and involves examining the limitations of ATCAL. The Army Integrated Mobilization Study, FY 1999 (AIMS 99) Combat Sample Generator (COSAGE) boards are used as the base case.

THE MAIN ASSUMPTIONS of the study are:

- (1) The results from the tactical simulation are the base truth to which ATCAL calibrates.
- (2) ATCAL logic and mathematics are correctly coded.
- (3) All direct fire issues are addressed in ATVAL I.
- (4) It is highly desirable for theater battle assessments to come directly from a high-resolution tactical simulation. This currently is not practical, and therefore a process (in this case ATCAL) which extrapolates from a high-resolution to a low-resolution model must be employed.
- (5) ATCAL emulates a high-resolution tactical simulation embedded within a theater model.

THE BASIC APPROACHES used in the study are to:

(1) Research indirect fire trends: examine historical data and results from other attrition models.

(2) Examine ATCAL Phase II: vary the quantity of shooters to determine if indirect fire ATCAL extrapolation is making sense by comparing it to the tactical simulation results.

(3) Examine ATCAL algorithms: if observed ATCAL results do not match expected results, both data inputs and current ATCAL algorithms will be examined to suggest improvements to the current process.

THE PRINCIPAL FINDINGS of the study are:

(1) The Field Artillery School and other models confirm that a functional relationship exists for indirect fire systems: there is a direct relationship between shooter density and total rounds expended.

(2) The ATCAL indirect fire algorithms do not maintain this functional relationship as they extrapolate from a base case to varying densities. When extrapolating to greater densities in ATCAL, the total rounds expended actually decrease. The converse is true when extrapolating to lesser densities.

(3) The current ATCAL process is able to replicate results when the same weapon system densities are used in the theater simulation as are used at the tactical level.

(4) There are alternative modifications to improve the current ATCAL algorithm. Each will enable ATCAL to maintain the accepted functional relationship as the algorithms extrapolate over a range of densities. Three alternatives have been described which can improve the representation of indirect fire in ATCAL. The cost to implement any of these alternatives is minimal.

THE STUDY EFFORT is directed by Mr. Neal W. Siegel, Force Evaluation Directorate.

COMMENTS AND QUESTIONS may be sent to the Director, US Army Concepts Analysis Agency, ATTN: CSCA-FET, 8120 Woodmont Avenue, Bethesda, Maryland 20814-2797.

Tear-out copies of this synopsis are at back cover.

CONTENTS

CHAPTER		Page
1	EXECUTIVE SUMMARY	1-1
	Purpose	1-1
	Background	1-1
	Problem	1-4
	Objectives	1-4
	Scope	1-4
	Assumptions	1-4
	Study Methodology	1-4
	Essential Elements of Analysis	1-5
	Recommendations	1-6
	ATVAL Phase II Study Report Synopsis	1-6
2	EXECUTING AND EVALUATING THE EXPERIMENT	2-1
	Experiments	2-1
	Experiment 1: Defining a Relationship between Shooter Density and Munition Expendables for Indirect Fire Systems	2-1
	Experiment 2: Examining the Current Extrapolation Process	2-3
	Experiment 3: Modifying Current Extrapolation Process to Include Average Number of Shooters	2-8
	Experiment 4: Using a Curve Fitting Function to Modify the Current ATCAL Extrapolation Process	2-13
	Experiment 5: Treating All Weapon Systems as Direct Fire	2-17
	Box and Whisker Plot Analysis	2-20
3	OBSERVATIONS	3-1
	General	3-1
	Observations and Conclusions	3-1
	Recommendations	3-2

APPENDIX		Page
A	Study Contributors	A-1
B	Study Directive	B-1
C	Bibliography	C-1
D	Current ATCAL Indirect Fire Expenditure Equations	D-1
E	Information Paper on Response Factor	E-1
F	Box and Whisker Plots	F-1
G	Distribution	G-1
GLOSSARY		Glossary-1

STUDY SUMMARY (*tear-out copies*)

FIGURES

FIGURE

1-1	The ATCAL Process	1-3
2-1	Experiment 2 Schematic	2-4
2-2	MLRS Rounds Expended in COSAGE and ATCAL Phase II	2-7
2-3	Response Factor Schematic	2-10
2-4	MLRS Rounds Expended in COSAGE and the Modified ATCAL Process	2-12
2-5	MLRS Rounds Expended in COSAGE and the Modified ATCAL Curve Fit Process	2-16
2-6	MLRS Rounds Expended in COSAGE and the Direct Fire ATCAL Process	2-19
2-7	MLRS Expenditures - 36 MLRS	2-20
2-8	MLRS Expenditures - 1 MLRS	2-20
E-1	Tank Kills 2X Quantity (72)	E-7
E-2	APC Kills 2X Quantity (72)	E-8
E-3	ARTY Kills 2X Quantity (72)	E-9
E-4	Tank Kills Standard Quantity (36)	E-10
E-5	APC Kills Standard Quantity (36)	E-11
E-6	ARTY Kills Standard Quantity (36)	E-12
E-7	Tank Kills (36 & 72 Comparison)	E-13
E-8	APC Kills (36 & 72 Comparison)	E-14
E-9	ARTY Kills (36 & 72 Comparison)	E-15
E-10	Total Shots (36 & 72 Comparison)	E-16
F-1	Total MLRS Expenditures - 1 MLRS	F-3
F-2	Total MLRS Expenditures - 3 MLRS	F-3
F-3	Total MLRS Expenditures - 6 MLRS	F-4
F-4	Total MLRS Expenditures - 9 MLRS	F-4
F-5	Total MLRS Expenditures - 18 MLRS	F-5
F-6	Total MLRS Expenditures - 36 MLRS	F-5

FIGURE

		Page
F-7	Total MLRS Expenditures - 72 MLRS	F-6
F-8	Total MLRS Expenditures - 108 MLRS	F-6
F-9	Total MLRS Expenditures - 144 MLRS	F-7
F-10	Total MLRS Expenditures - 252 MLRS	F-7
F-11	Total Kills by MLRS - 1 MLRS	F-8
F-12	Total Kills by MLRS - 3 MLRS	F-8
F-13	Total Kills by MLRS - 6 MLRS	F-9
F-14	Total Kills by MLRS - 9 MLRS	F-9
F-15	Total Kills by MLRS - 18 MLRS	F-10
F-16	Total Kills by MLRS - 36 MLRS	F-10
F-17	Total Kills by MLRS - 72 MLRS	F-11
F-18	Total Kills by MLRS - 108 MLRS	F-12
F-19	Total Kills by MLRS - 144 MLRS	F-12
F-20	Total Kills by MLRS - 252 MLRS	F-12

TABLES

TABLE

1-1	Model (M) and Processor (P) Definitions	1-3
2-1	Cosage MLRS Shooter Density vs Expenditures	2-2
2-2	TAFSM MLRS Shooter Density vs Expenditures	2-3
2-3	Comparison of Total MLRS Rounds Expended	2-5
2-4	Comparison of MLRS Rounds per Kill	2-5
2-5	Comparison of MLRS Average Density	2-6
2-6	Comparison of MLRS Importances	2-6
2-7	Comparison of Total MLRS Rounds Expended	2-10
2-8	Comparison of MLRS Rounds per Kill	2-11
2-9	Comparison of MLRS Average Density	2-11
2-10	Comparison of MLRS Importances	2-12
2-11	Comparison of Total MLRS Rounds Expended	2-14
2-12	Comparison of MLRS Rounds per Kill	2-14
2-13	Comparison of MLRS Average Density	2-15
2-14	Comparison of MLRS Importances	2-15
2-15	Comparison of Total MLRS Rounds Expended	2-17
2-16	Comparison of MLRS Rounds per Kill	2-17
2-17	Comparison of MLRS Average Density	2-18
2-18	Comparison of MLRS Importances	2-18
E-1	Response Factor Multiplier Table	E-17

CHAPTER 1

EXECUTIVE SUMMARY

1-1. **PURPOSE.** The reason for performing this study is to learn more about the indirect fire algorithms in the Attrition Calibration (ATCAL) model.

1-2. **BACKGROUND**

a. During the early 1980s, a method of computing equipment and personnel losses was formulated by Dr. Alan Johnsrud based on operational probabilities of kill. This new algorithm was named ATCAL, an Attrition Model using Calibrated Parameters. ATCAL was destined to become the heart of attrition calculations in theater models such as the Concepts Evaluation Model (CEM), Force Evaluation Model (FORCEM), TAC THUNDER, and RAND Corporation's CADEM. Basically, ATCAL replaces the way in which theater-level attrition is handled. Before 1983, losses of equipment and personnel were computed as firepower scores. It was decided to abandon this method in favor of one which is based on operational probabilities of kill, ATCAL.

b. Simply put, ATCAL is the link between the theater- and tactical-level models. A tactical-level model is utilized to provide combat samples to theater-level models. The ideal situation is to have the tactical-level simulation performed as part of the theater cycle (a 12-hour period); however, most computers do not have sufficient capacity or speed to make this practical. In lieu of this, ATCAL is designed to transfer information consisting of individual weapon/target shot and kill matrices from tactical-level results to each individual theater cycle.

c. ATCAL operates in two phases: Phase I calibrates the results derived from the tactical model. The variables shown below are those that have an effect on indirect fire systems.

- Shots: Primary (and secondary) ammo type expended at a target type.
- Kills: Kills of vehicle type by a weapon system.
- PK: Operational probability of kill. Takes into account the synergisms of battle and their effect on static probability of kill. Calculated by dividing kills by shots.

These variables lead to the calculation of the following calibration parameters:

- Response: A demand for fire which leads to a number of rounds fired.
- Lethality: Essentially an operational probability of kill for indirect fire systems.
- Bias: Apportions the total rounds fired by a given shooter among its different round types.

d. Phase II uses these calibration parameters to extrapolate to during each individual theater cycle. In the theater, quantities of equipment, engagement ranges, frontage widths, and unit composition vary greatly from that seen in the tactical model. ATCAL must extrapolate for each case to provide the appropriate number of shots, kills and PKs for each equipment type.

e. A previous examination of ATCAL occurred in 1990. In his evaluation of ATCAL, Mr. Hugh Jones, Force Evaluation Directorate, CAA, examined issues specifically concerning direct fire. The findings for the representation of direct fire in ATCAL can be found in his report, ATVAL Phase I (Study Report CAA-SR-91-10).

f. The theater modeling process at CAA involves a number of models and processors in its schema. Central to this process is ATCAL. As previously discussed, ATCAL is the link between the tactical- and theater-level models. Complicating the explanation of ATCAL is the fact that ATCAL itself is comprised of two parts: ATCAL Phase I and ATCAL Phase II. ATCAL Phase I (also known as Reduction ATCAL Link, Phase I (RALPH)) is the calibration phase, and ATCAL Phase II (also known as standalone) is the extrapolation phase. The definitions are listed in Table 1-1.

g. The relationship between the tactical simulation, ATCAL, and the theater model is shown in Figure 1-1. The tactical simulation, in this case COSAGE, portrays specific units, such as infantry, armor, aviation, and artillery. Each unit is modeled as accurately as feasible with respect to tactics and doctrine. The results of each of the individual engagements and activities is a set of statistics that is passed by ATCAL Phase II to the theater model, in this case CEM. ATCAL uses a set of algorithms to take the tactical simulation results and develop a set of statistics that is passed to and used by the theater-level model. ATCAL itself does not directly consider tactics or doctrine.

Table 1-1. Model (M) and Processor (P) Definitions

Acronym	Name and purpose
COSAGE (M)	Combat Sample Generator. Two-sided, symmetrical, mid-resolution, stochastic combat simulation. Models ground-to-ground, ground-to-air and air-to-ground combat. This model develops shooter/target interactions and final killer/victim matrix upon which the ATCAL calibration parameters are based.
RALPH (P)	Reduction ATCAL Link, Phase I. This processor has two basic functions. First, it rolls up equipment from COSAGE so that the expected equipment to be played in CEM fits the stringent CEM number of equipment limitations. The second function of the RALPH processor is to calibrate the data from COSAGE according to the equations listed in CAA Technical Paper CAA-TP-83-3, ATCAL: An Attrition Model Using Calibrated Parameters.
ATCAL AND STANDALONE ATCAL (P)	This is the iterative process which employs a convergence scheme to compute attrition and shots fired offline for both direct and indirect fire weapon systems. The standalone ATCAL code is the same as that embedded in CEM. It is used for offline examinations.
CEM (M)	Concepts Evaluation Model. CEM is a two-sided, fully automated, deterministic computer simulation capable of aggregating conventional land and air warfare results over an extended campaign. Attrition and ammo consumption are computed via ATCAL, embedded within the CEM code.

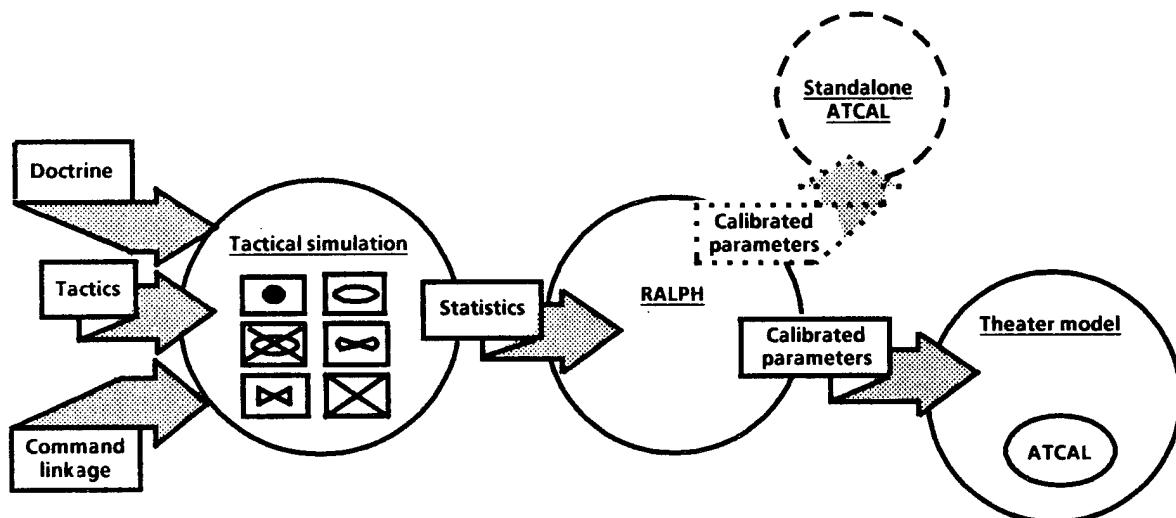

Figure 1-1. The ATCAL Process

b. Standard operating procedure passes Phase I results to the Phase II ATCAL module embedded in the theater model. However, for the purposes of this study, the standalone ATCAL module is used.

1-3. **PROBLEM.** The specific question to answer is: how well does ATCAL extrapolate indirect fire using calibrated parameters to compute attrition and rounds fired in theater models?

1-4. **OBJECTIVES.** There are three objectives of this study.

a. **Objective 1.** Determine how closely extrapolated ATCAL results compare with observed and/or expected indirect fire trends.

b. **Objective 2.** Determine a functional relationship between munition expenditures and force size as represented through ATCAL. Also, determine a similar functional relationship for COSAGE and the Target Acquisition and Force Simulation Model (TAFSM). TAFSM is the model utilized by the Field Artillery School, Fort Sill, Oklahoma.

c. **Objective 3.** Determine any shortcomings of ATCAL and decide if there are any modifications to ATCAL which would improve the portrayal of indirect fire.

1-5. **SCOPE.** The scope of the study includes two main focuses, both of which center around artillery issues. The first is research oriented and involves examining other models. Data from this phase will be compared to artillery results generated by using the ATCAL process. The second focus is analytically oriented and involves examining the limitations of ATCAL. The Army Integrated Mobilization Study, FY 1999 (AIMS 99) Combat Sample Generator (COSAGE) boards are used as the base case.

1-6. **ASSUMPTIONS.** Three assumptions made for this research project are:

a. The results from the tactical simulation are the base truth to which ATCAL calibrates.

b. ATCAL logic and mathematics are correctly coded. It is assumed that the computer code accurately reflects the objectives in CAA-TP-83-3, ATCAL: An Attrition Model Using Calibrated Parameters.

c. All direct fire issues have been addressed in ATVAL I and will not require any further examination in this study.

1-7. **STUDY METHODOLOGY**

a. There are two overall aspects to the study methodology: a research-oriented aspect and an analytically-oriented aspect.

b. The research-oriented aspect consists of examining indirect fire historical functional relationships and results produced by other models. These indirect fire relationships are then compared to the ATCAL produced results.

c. The second aspect of the study is analytical in nature. The first step is to test ATCAL's robustness by determining the critical parameters used by the algorithms and the range over which they are valid. Using the AIMS 99 data as the base case, COSAGE input parameters such as shooter and sensor density are modified to test how ATCAL responds.

d. The final step of the study is to exercise ATCAL's ability to extrapolate in Phase II. AIMS 99 COSAGE boards are used to develop the base case expected results against which the Phase II expected results are compared to determine if ATCAL extrapolates properly.

e. There are five experiments that follow the same methodology. ATCAL is used to extrapolate from a set of base case calibration parameters to varying levels of a shooter density. To determine if ATCAL extrapolates to results similar to the tactical-level model, COSAGE boards are developed which correspond to each of the extrapolation cases. The results of these COSAGE boards are then compared to the results from the extrapolation process.

1-8. **ESSENTIAL ELEMENTS OF ANALYSIS (EEA).** The following are the essential elements of analysis and their responses.

a. **EEA 1. How well do ATCAL excursions compare to the observed values from a tactical simulation?**

The ATCAL indirect fire algorithms do not maintain the same functional relationship as the tactical simulation as they extrapolate from a base case to varying shooter densities. The reason for this deficiency is that the current ATCAL algorithms are based solely on target density.

b. **EEA 2. How well do ATCAL results compare to the functional relationships observed from other models currently in use?**

The Field Artillery School and other models confirm that a functional relationship does exist for indirect fire systems: there is a direct relationship between shooter density and total rounds expended. ATCAL does not maintain the same shooter/expenditure relationship observed in the Field Artillery School's model or as expected by the doctrine of the Field Artillery School.

c. **EEA 3. Are there modifications to ATCAL that would improve its projection of indirect fire?**

There are three possible modifications available to improve the ATCAL algorithm:

(1) Including the average number of shooters in the Phase I and Phase II equations.

(2) Using a curve fitting technique to modify the current indirect fire equations.

(3) Using the direct fire algorithm to extrapolate for both direct and indirect fire systems.

Any one will enable ATCAL to maintain the accepted functional relationship as the algorithms extrapolate over a range of shooter densities.

1-9. RECOMMENDATIONS

a. Indirect fire equations in ATCAL need to be modified to reflect current doctrine. This study found three alternative methodologies which warrant further investigation as discussed in Chapter 3.

b. Examine the impact each of the proposed methodologies has on theater-level modeling.

1-10. ATVAL PHASE II STUDY REPORT SYNOPSIS

a. The study report is divided into three chapters. Chapter 2 is devoted to explaining five experiments conducted during the study. Observations and conclusions on the experiments are discussed and elaborated on using figures and tables.

b. Chapter 3 summarizes these observations and conclusions. Recommendations are also presented.

Table 2-2. TAFSM MLRS Shooter Density vs Expenditures^a

<u>Shooter density</u>	<u>Expenditures</u>
1	96
3	223
6	537
9	626
18	1033
36	1847
72	2072

^aBased on 12-hour simulation.

c. **Conclusion.** As expected, the numbers for the two cases do not match. However, the overall functional relationship is consistent between the two models; as the number of shooters increases, the total expenditures also increase. Although this functional relationship may appear to be obvious, it will be shown later that this is not the same functional relationship currently reflected in ATCAL as it extrapolates for increasing or decreasing numbers of shooters.

2-3. EXPERIMENT 2: EXAMINING THE CURRENT EXTRAPOLATION PROCESS

a. **Background.** In modeling, two constraints that are of primary concern are time and computer storage capacity. CAA's modeling process is no different. Because of time constraints, it is not practical to build the number of combat samples necessary to represent the infinite number of possible combinations of combat situations in the theater model. Due to computer constraints, it is not currently possible to have the tactical simulation as an integral part of the overall theater model. Thus it is necessary to develop a limited number of combat samples separately for the theater model. The purpose of ATCAL is to fill the requirement for an infinite number of combat samples by using a limited number of combat samples. ATCAL does this by taking the results of the combat samples and creating a set of statistics. These statistics are then used to extrapolate to various theater-level cases.

b. **Experiment.** For the purpose of this experiment, the AIMS 99 Europe defense intense COSAGE board is used as the base case. In this posture, the initial MLRS density is 36 launchers. The ATCAL process is used to extrapolate from the calibration parameters developed for the base case of 36 MLRS to varying MLRS quantities (1 through 252) at the theater level. While these MLRS densities may appear unlikely, they are selected to test the limits of ATCAL's capabilities. To determine if ATCAL extrapolates to results similar to the tactical-level model, COSAGE boards which correspond to each of the extrapolation cases are developed. The results of these COSAGE boards are

then compared to the results from the ATCAL extrapolation process. A schematic of this experiment is shown in Figure 2-1. Results from COSAGE and the ATCAL extrapolation observed results are presented in Tables 2-3 through 2-6.

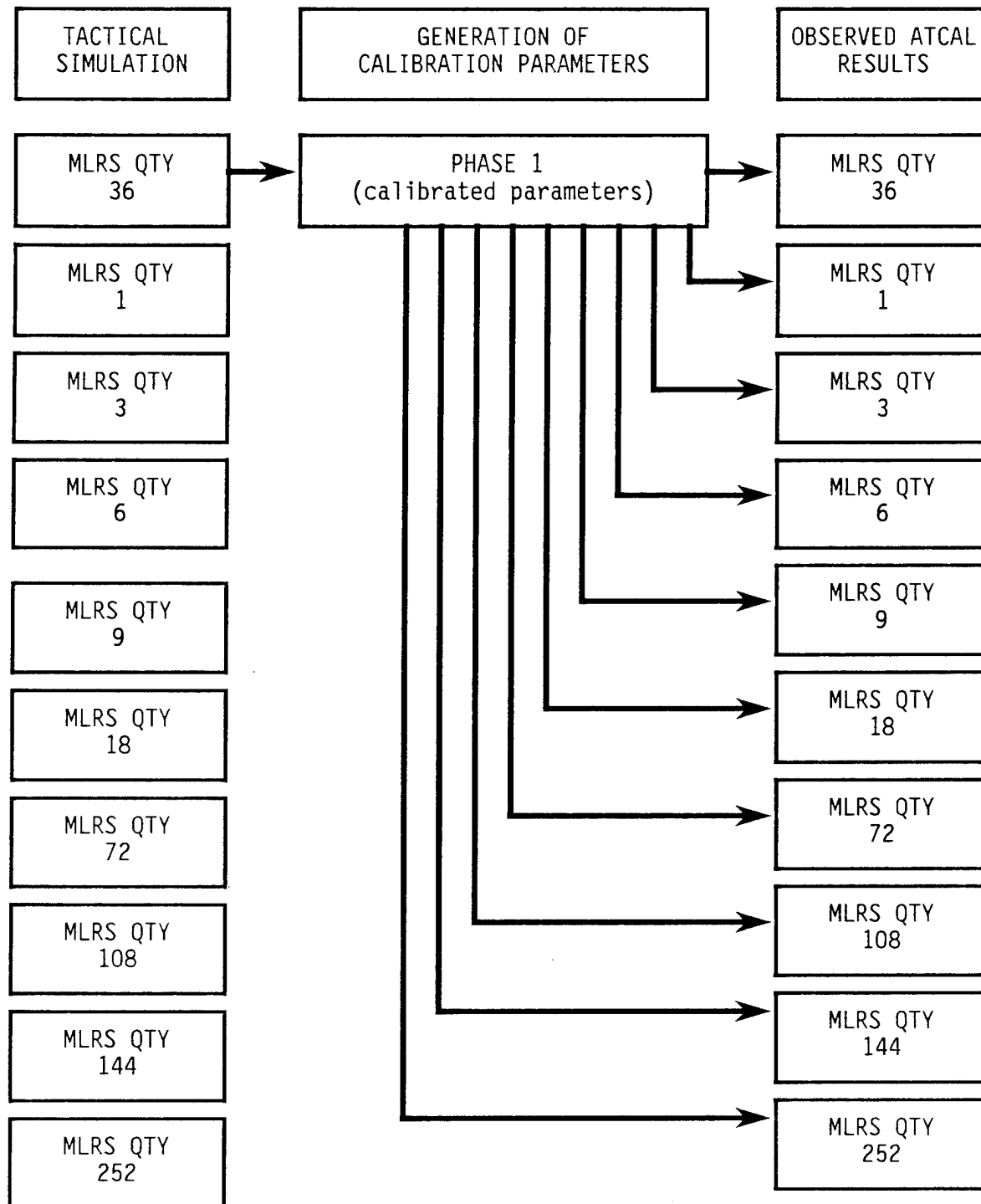

Figure 2-1. Experiment 2 Schematic

Table 2-3. Comparison of Total MLRS Rounds Expended

<u>Initial MLRS density</u>	<u>COSAGE results</u>	<u>ATCAL results</u>
1	31	1068
3	105	718
6	155	562
9	265	504
18	290	445
36	414	414
72	579	397
108	746	390
144	831	387
252	1577	382

Table 2-4. Comparison of MLRS Rounds per Kill

<u>Initial MLRS density</u>	<u>COSAGE results</u>	<u>ATCAL results</u>
1	4.21	4.28
3	4.44	4.13
6	4.42	4.08
9	4.49	4.05
18	4.05	4.03
36	4.01	4.01
72	4.25	4.00
108	4.36	4.00
144	4.61	4.00
252	5.46	4.00

Table 2-5. Comparison of MLRS Average Density

<u>Initial MLRS density</u>	<u>COSAGE results</u>	<u>ATCAL results</u>
1	1.0	1.0
3	2.6	2.9
6	5.5	5.9
9	8.2	8.8
18	16.5	17.7
36	34.3	35.6
72	68.9	71.4
108	106.0	107.3
144	139.4	143.2
252	245.8	251.1

Table 2-6. Comparison of MLRS Importances

<u>Initial MLRS density</u>	<u>COSAGE results</u>	<u>ATCAL results</u>
1	.006884	.173600
3	.008278	.036310
6	.005413	.013530
9	.004949	.007908
18	.002865	.003405
36	.001562	.001562
72	.001033	.000742
108	.000815	.000485
144	.000643	.000360
252	.000446	.000203

c. **Observations.** The data in Tables 2-3 through 2-6 reflect how different the ATCAL extrapolated results are when compared to the tactical-level results. Figure 2-2 graphically depicts the difference in total rounds expended between COSAGE and the current ATCAL extrapolation process. The total rounds expended and the MLRS productivities in ATCAL currently reflect a relationship that is opposite of that seen in the results of the tactical-level simulation. The differences in average density between the tactical-level simulation and ATCAL results do not appear significant. However, the ratio of the average densities does affect the total rounds expended in the theater. Table 2-6 shows the vast difference in the importances as calculated by the tactical-level simulation and ATCAL. Both sets of importances reflect the same general trends; they are inversely related to system density. It will be shown later that the importance has a direct impact on the total rounds expended in the theater.

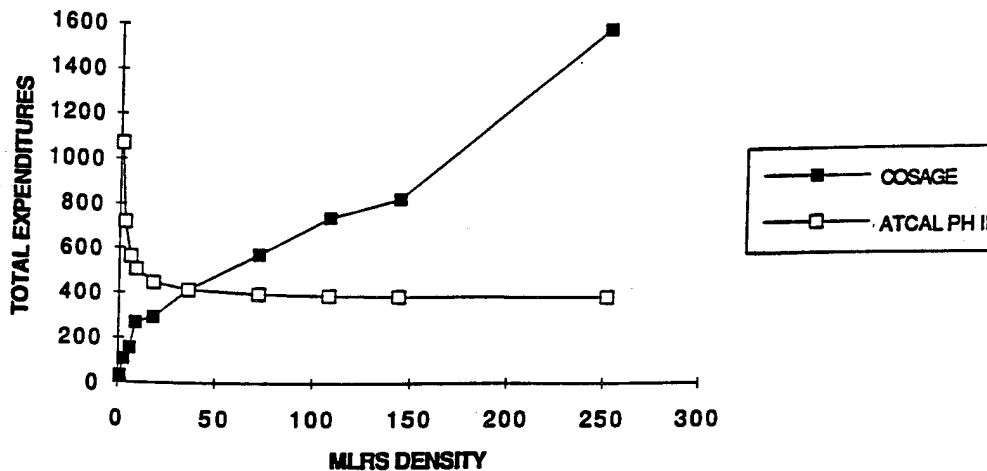

Figure 2-2. MLRS Rounds Expended in COSAGE and ATCAL Phase II

d. **Conclusion.** As depicted in Table 2-3, ATCAL does not maintain the same functional relationship as reflected by the COSAGE and TAFSM results and as described in paragraph 2-2b and 2-2c. In fact, ATCAL behaves exactly opposite of results obtained from the tactical-level simulations. The number of shots calculated by the current indirect fire algorithm is target dependent and shooter independent. Thus, an increase in the number of shooters in ATCAL does not increase the number of rounds expended as expected, and as confirmed by the tactical-level results. The increase in density in fact makes the shooter a more vulnerable target to other weapon systems. This results in an increase in shooter attrition and a decrease in the overall munition expenditures. This is important because the number of kills by an artillery system is directly related to the number of rounds expended. Thus, not only are the number of shots skewed, but so is the contribution of artillery to total kills. This is further explained by the examination of the ATCAL indirect fire algorithm in Appendix D. It should be noted that when ATCAL extrapolates to the identical system density (in this case MLRS = 36 at the tactical and theater levels), it is able to replicate the results observed in the tactical-level case. Thus, the algorithms

satisfactorily replicate given identical tactical- and theater-level shooter densities, but are insufficient to extrapolate under varying densities. Subsequent experiments modify the ATCAL indirect fire algorithms to more closely approximate the expected functional relationship discussed earlier.

2-4. EXPERIMENT 3: MODIFYING CURRENT EXTRAPOLATION PROCESS TO INCLUDE AVERAGE NUMBER OF SHOOTERS

a. Background. Examination of each of the variables in the rounds calculation reveals that the response factor has the greatest effect on total rounds expended in the ATCAL indirect fire equations. Work performed in conjunction with this study demonstrates the impact of varying the response factor in relation to total rounds expended in ATCAL Phase II. Reference appendix E for more information on modifying the ATCAL response factor.

b. Experiment

(1) Based on this initial work, the purpose of this experiment is to modify the ATCAL equations with respect to response factor. Although the equations in Phase I and Phase II use the same terms, only RSPNS_i and L_{ijk} (the calibration parameters) are actually passed from Phase I to Phase II. The other terms are internally calculated and are only used with their specific phase. For example, \bar{N}_i is used to represent the average density in both the Phase I and II equations. However, the average density in Phase I (tactical-level simulation) is different than the average density in Phase II (theater-level simulation). This is in keeping with the author's original notation. The attempt is to create an algorithm which maintains the functional relationship demonstrated by the tactical-level models as discussed in paragraph 2-2b and 2-2c. The current ATCAL algorithms are modified (using a linear equation) to make them dependent upon shooter density in addition to being dependent on target density. Both the rounds expended (calculated in Phase II) and the response factor (calculated in Phase I) are modified by the average number of shooters, \bar{N}_i as shown in the following equations. Reference Appendix D for an explanation of each variable.

Current equation:

$$(ROUNDS)_i = (RSPNS)_i * L_{ijk} * (IM)_k * \bar{N}_k \quad \text{Phase II}$$

$$(RSPNS)_i = \frac{(ROUNDS)_{ij}}{P_{ijk} * (IM)_k * \bar{N}_k} \quad \text{Phase I}$$

Modified equation:

$$(ROUNDS)_i = (RSPNS)_i * L_{ijk} * (IM)_k * \bar{N}_k * \bar{N}_i \quad \text{Phase II}$$

$$(RSPNS)_i = \left(\frac{(ROUNDS)_{ij}}{P_{ijk} * (IM)_k * \bar{N}_k} \right) / \bar{N}_i \quad \text{Phase I}$$

(2) The average number of shooters, \bar{N}_i is selected instead of the initial shooter density, \bar{N}_i to take into account the effect of decreasing numbers of shooters over time. By adding \bar{N}_i into the equation in Phase I as shown above, the response factor becomes a function of the number of shooters (response per shooter). In Phase II, the rounds calculation is also modified by multiplying this factor (response per shooter) by the average number of shooters. This has the effect of increasing the rounds expended as ATCAL extrapolates to greater shooter densities and conversely decreasing the rounds expended as shooter densities decrease.

(3) Figure 2-3 is a simplified schematic of the effect of a response factor that is shooter density independent (current ATCAL equations) versus one in which the response factor is dependent on shooter density (modified ATCAL equations). As shown in the equations above, all four variables have a direct impact on the rounds calculation. However, the response factor has the most direct impact, as discussed in Appendix E. In the current ATCAL algorithm, extrapolations above or below the base case are not impacted by the response factor, which remains constant. Thus, the only effect upon the rounds calculation is due to the other target dependent variables. In the modified version, response is made shooter dependent. Thus, the total rounds expended becomes a function of shooter density as well as target density. The procedure used in experiment 2 is repeated using the modified ATCAL equations. Tables 2-7 through 2-10 display the results of this experiment.

TACTICAL LEVEL RESULTS:

(EXAMPLE ONLY)

414 ROUNDS EXPENDED BY:

36 SHOOTERS (\bar{N}_i)

RESPONSE FACTOR CALCULATION

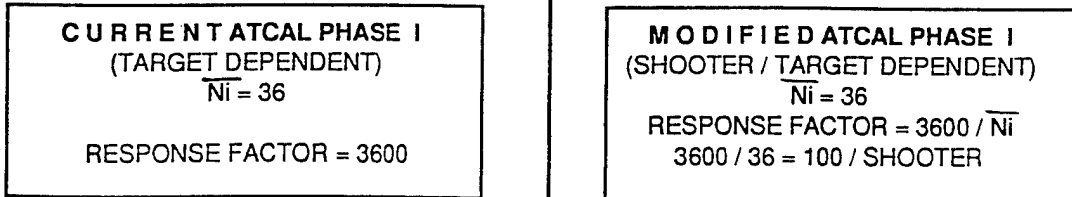

TOTAL ROUNDS EXTRAPOLATED AT THE THEATER LEVEL YIELDS:

(ATCAL PHASE II)

FOR DENSITIES =	$\bar{N}_i = 18$	$\bar{N}_i = 72$	$\bar{N}_i = 18$	$\bar{N}_i = 72$
RESPONSE FACTOR	3600	3600	$100 \times 18 = 1800$	$100 \times 72 = 7200$
RESPONSE FACTOR	3600	3600	1800	7200
X PHASE II INTERNAL CALCULATIONS	<u>X .1236</u>	<u>X .1103</u>	<u>X .1262</u>	<u>X .1007</u>
TOTAL ROUNDS	445	397	228	725

Figure 2-3. Response Factor Schematic

Table 2-7. Comparison of Total MLRS Rounds Expended

<u>Initial MLRS density</u>	<u>COSAGE results</u>	<u>Modified ATCAL results</u>
1	31	15
3	105	43
6	155	83
9	265	122
18	290	228
36	414	414
72	579	725
108	746	992
144	831	1234
252	1577	1861

Table 2-8. Comparison of MLRS Rounds per Kill

<u>Initial MLRS density</u>	<u>COSAGE results</u>	<u>Modified ATCAL results</u>
1	4.21	2.18
3	4.44	3.91
6	4.42	3.89
9	4.49	3.92
18	4.05	3.95
36	4.01	4.04
72	4.25	4.08
108	4.36	4.09
144	4.61	4.21
252	5.46	4.31

Table 2-9. Comparison of MLRS Average Density

<u>Initial MLRS density</u>	<u>COSAGE results</u>	<u>Modified ATCAL results</u>
1	1.0	1.0
3	2.6	2.9
6	5.5	5.9
9	8.2	8.8
18	16.5	17.7
36	34.3	35.6
72	68.9	71.4
108	106.0	107.3
144	139.4	143.2
252	245.8	251.1

Table 2-10. Comparison of MLRS Importances

<u>Initial MLRS density</u>	<u>COSAGE results</u>	<u>Modified ATCAL results</u>
1	.006884	.002809
3	.008278	.002670
6	.005413	.002491
9	.004949	.002338
18	.002865	.001989
36	.001562	.001560
72	.001033	.001131
108	.000815	.000904
144	.000643	.000763
252	.000446	.000533

c. **Observations.** The results of the modified version of ATCAL reflected in Tables 2-7 through 2-10 more closely approximate the results observed from the tactical simulation. Figure 2-4 shows the similarity in total expenditures as a function of shooter density. Total rounds expended in the ATCAL algorithms are now increasing as shooter density increases. Similarly, the MLRS productivity (rounds/kill) in ATCAL more closely mimics the tactical-level simulation. Changes to the ATCAL algorithms do not affect the calculation of the average densities and thus the average densities shown in Table 2-9 are the same as those reflected in Table 2-5. The MLRS importances shown in Table 2-10 more closely approximate the COSAGE results and have a smaller difference than those in the current ATCAL process (Table 2-6).

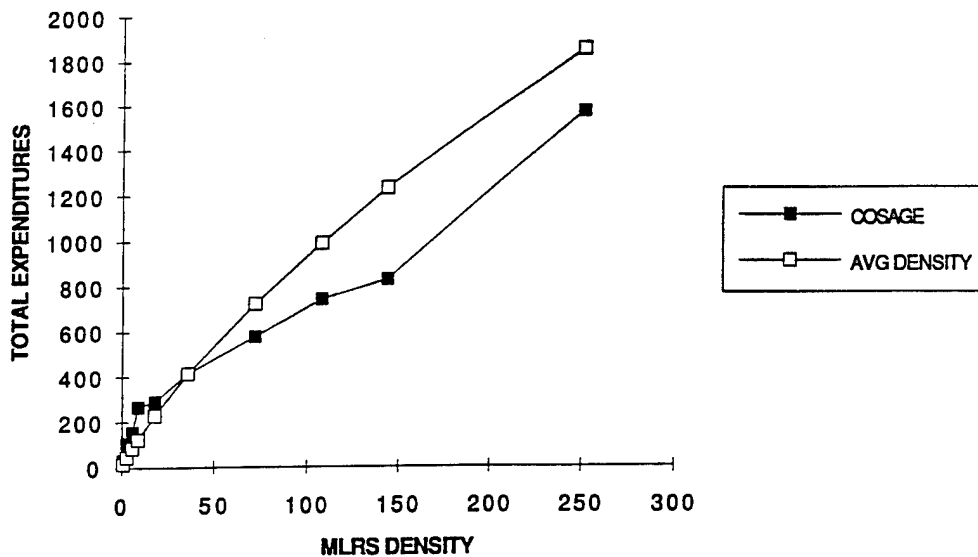

Figure 2-4. MLRS Rounds Expended in COSAGE and the Modified ATCAL Process

d. **Conclusion.** Including the average shooter density in the ATCAL equations does not modify the equation enough to produce results exactly replicating the numbers seen in the tactical simulation. The modified equations do however, extrapolate to a functional relationship that more closely approximates that of the tactical simulation. A comparison of Table 2-7 and Table 2-3 reflects the differences between the modified version and the current version of ATCAL. This reinforces what is observed in the tactical-level simulations, that the number of rounds expended is in fact dependent upon shooter density in addition to target density.

2-5. EXPERIMENT 4: USING A CURVE FITTING FUNCTION TO MODIFY THE CURRENT ATCAL EXTRAPOLATION PROCESS

a. **Background.** The modifications to the equations in the previous experiments improve the results as ATCAL extrapolates. To further refine the extrapolation process to more closely approximate the functional relationships previously observed, data from tactical-level simulations are used to develop a curve fitting function.

b. **Experiment.** The number of rounds expended versus the MLRS shooter densities from the tactical-level simulations are plotted and a curve fitting equation is calculated. The curve that best fits this functional relationship is logarithmic in nature and is shown below.

$$\ln(Y) = 3.43 + 0.871\ln(X)$$

where Y is total rounds expended

X is MLRS shooter density

This function is used in the Phase I response and Phase II rounds calculation equations as shown below.

Current equation:

$$(ROUNDS)_i = (RSPNS)_i * L_{ijk} * (IM)_k * \bar{N}_k \quad \text{Phase II}$$

$$(RSPNS)_i = \frac{(ROUNDS)_{ij}}{P_{ijk} * (IM)_k * \bar{N}_k} \quad \text{Phase I}$$

Curve fitting equation:

$$(ROUNDS)_i = (RSPNS)_i * L_{ijk} * (IM)_k * \bar{N}_k * \ln(Y) \quad \text{Phase II}$$

$$(RSPNS)_i = \left(\frac{(ROUNDS)_{ij}}{P_{ijk} * (IM)_k * \bar{N}_k} \right) / \ln(Y) \quad \text{Phase I}$$

Tables 2-11 through 2-14 compare the COSAGE results with the ATCAL results using the above curve fitting equations.

Table 2-11. Comparison of Total MLRS Rounds Expended

<u>Initial MLRS density</u>	<u>COSAGE results</u>	<u>Curve fit ATCAL results</u>
1	31	24
3	105	60
6	155	106
9	265	146
18	290	249
36	414	414
72	579	672
108	746	884
144	831	1071
252	1577	1540

Table 2-12. Comparison of MLRS Rounds per Kill

<u>Initial MLRS density</u>	<u>COSAGE results</u>	<u>Curve fit ATCAL results</u>
1	4.21	3.88
3	4.44	3.89
6	4.42	3.92
9	4.49	3.93
18	4.05	3.97
36	4.01	4.01
72	4.25	4.08
108	4.36	4.13
144	4.61	4.18
252	5.46	4.26

Table 2-13. Comparison of MLRS Average Density

<u>Initial MLRS density</u>	<u>COSAGE results</u>	<u>Curve fit ATCAL results</u>
1	1.0	1.0
3	2.6	2.9
6	5.5	5.9
9	8.2	8.8
18	16.5	17.7
36	34.3	35.6
72	68.9	71.4
108	106.0	107.3
144	139.4	143.2
252	245.8	251.1

Table 2-14. Comparison of MLRS Importances

<u>Initial MLRS density</u>	<u>COSAGE results</u>	<u>Curve fit ATCAL results</u>
1	.006884	.004599
3	.008278	.003692
6	.005413	.003100
9	.004949	.002744
18	.002865	.002134
36	.001562	.001561
72	.001033	.001076
108	.000815	.000844
144	.000643	.000704
252	.000446	.000485

c. **Observations.** The ATCAL results as reflected in Tables 2-11 through 2-14 show an even closer representation of the trends observed from the tactical-level simulation. Figure 2-5 also depicts how closely the curve fit equations replicate the tactical-level simulation. Most significantly, the ATCAL calibrated importances (Table 2-14) demonstrate a marked improvement over the previous experiment, specifically in the higher shooter densities.

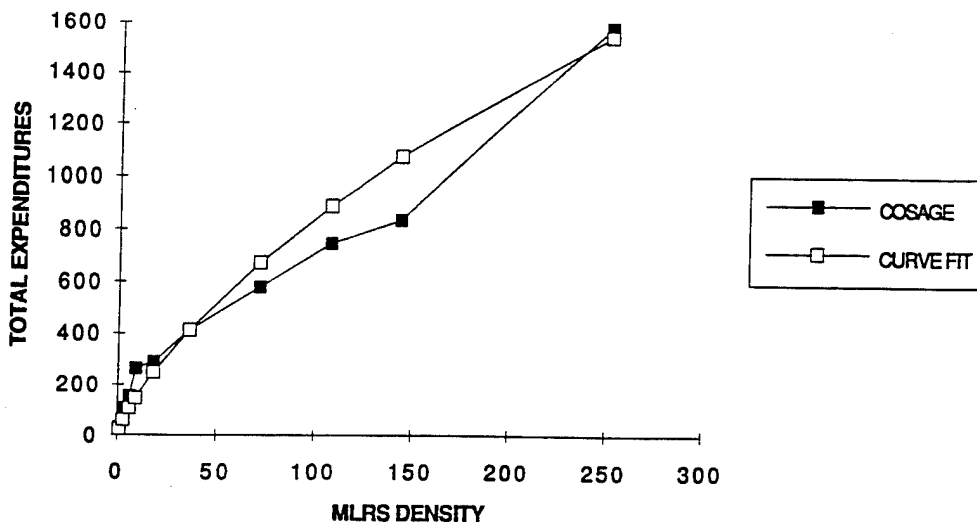

Figure 2-5. MLRS Rounds Expended in COSAGE and ATCAL Curve Fit Process

d. **Conclusion.** The curve fitting function produces better ATCAL extrapolated results than the results observed using the linear equation technique discussed in Experiment 3. Since each of the indirect fire systems is represented by a unique functional relationship, the drawback to this approach is that the ATCAL algorithms, as currently structured, can only incorporate one of the indirect fire system's functional relationship.

2-6. EXPERIMENT 5: TREATING ALL WEAPON SYSTEMS AS DIRECT FIRE

a. **Background.** ATCAL is comprised of two different sets of algorithms: one set of equations for direct fire weapons and another set for indirect fire weapons. While the output for each is the same, the treatment of indirect fire weapons is quite different from that of direct fire. For example, target availability for direct fire weapons is a function of force frontage. However, indirect fire, while not actually portraying target availability, is not concerned with force frontage for any of the calculations. In the direct fire algorithm, the total rounds expended is a function of both the number of shooters and targets. The previous experiments demonstrate the need for a change in the indirect fire algorithm. It has been shown that the addition of the number of shooters to the rounds expended equation improves the algorithm significantly. The direct fire algorithm already considers the shooter density. The intent of this experiment is to determine if the set of direct fire algorithms can appropriately be applied to both the direct and indirect fire systems.

b. **Experiment.** This experiment treats all weapon systems as if they are direct fire systems during the extrapolation process. This is accomplished by defining each weapon system as a direct fire system in the initial ATCAL input file. Although this may appear doctrinally incorrect, remember that no modifications are made to the portrayal of indirect fire systems in the tactical-level simulation. Indirect fire systems continue to be modeled according to doctrine during the simulation. It is only in the extrapolation process that the systems are being treated as direct fire. Results of this experiment are reflected in Tables 2-15 through 2-18.

Table 2-15. Comparison of Total MLRS Rounds Expended

<u>Initial MLRS density</u>	<u>COSAGE results</u>	<u>Direct fire ATCAL results</u>
1	31	12
3	105	35
6	155	71
9	265	106
18	290	210
36	414	413
72	579	801

Table 2-16. Comparison of MLRS Rounds per Kill

<u>Initial MLRS density</u>	<u>COSAGE results</u>	<u>Direct fire ATCAL results</u>
1	4.21	2.53
3	4.44	3.41
6	4.42	4.23
9	4.49	4.32
18	4.05	4.20
36	4.01	4.16
72	4.25	4.11

Table 2-17. Comparison of MLRS Average Density

<u>Initial MLRS density</u>	<u>COSAGE results</u>	<u>Direct fire ATCAL results</u>
1	1.0	1.0
3	2.6	3.0
6	5.5	5.9
9	8.2	8.9
18	16.5	17.8
36	34.3	35.6
72	68.9	71.2

Table 2-18. Comparison of MLRS Importances

<u>Initial MLRS density</u>	<u>COSAGE results</u>	<u>Direct fire ATCAL results</u>
1	.006884	.002108
3	.008278	.002057
6	.005413	.001989
9	.004949	.001927
18	.002865	.001775
36	.001562	.001561
72	.001033	.001300

c. **Observations.** While the results reflected in Tables 2-15 through 2-18 follow the same general trends as seen in the tactical-level simulation, they are not as good as those observed in the previous two experiments. Figure 2-6 presents a graphical representation of how well the direct fire algorithms mimic the tactical-level results. Most notably, the range of the MLRS importances is markedly decreased. Additionally, the productivity results in ATCAL are much greater than those observed from the tactical-level simulation and the other experiments. However, the expenditures of the other indirect fire systems experience less variation in this case than in the previous experiments.

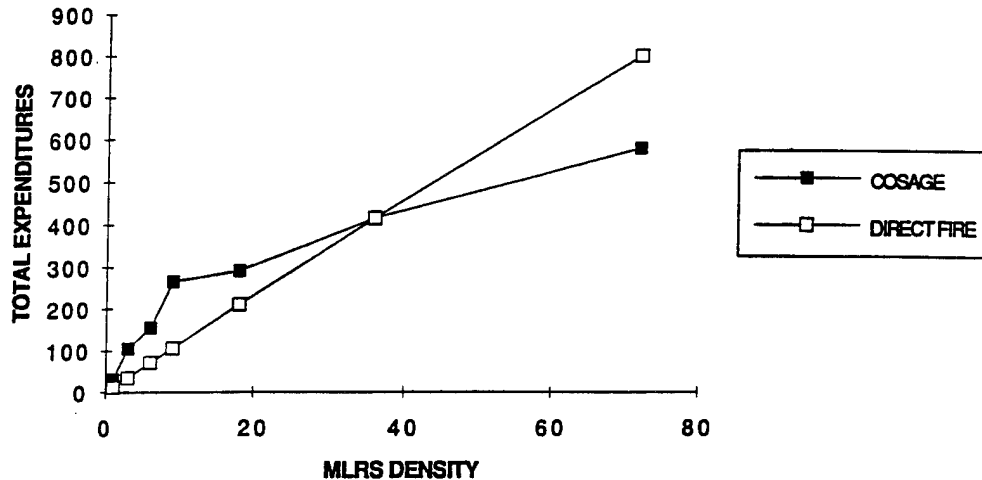

Figure 2-6. MLRS Rounds Expended in COSAGE and the Direct Fire ATCAL Process

d. **Conclusion.** Although these results are better than the current ATCAL process, they are not as good as the results observed from the previous two experiments. This approach does have one significant advantage over the other two: simplicity. One set of algorithms is used to calculate attrition and expenditures for both the direct and indirect fire systems.

2-7. BOX AND WHISKER PLOT ANALYSIS

a. Ten replications of COSAGE are run using different stochastic possibilities to obtain shot and kill data. These data points are transmitted to the theater model (through ATCAL) as an average shot or kill. The individual points for each of the 10 COSAGE replications can be compared to the single point that is extrapolated to by ATCAL. The box and whisker plots address whether ATCAL produces a value that falls within the COSAGE range of values. Appendix F has an explanation of box and whisker plots and contains the box and whisker plots developed for each of the MLRS densities examined in the experiments.

b. Figure 2-7 shows the box and whisker plot developed from 10 COSAGE replications for the base case (36) MLRS expenditures. The ATCAL extrapolated value for each of the experiments is within the box, demonstrating ATCAL's ability to produce similar results when extrapolating to the same density.

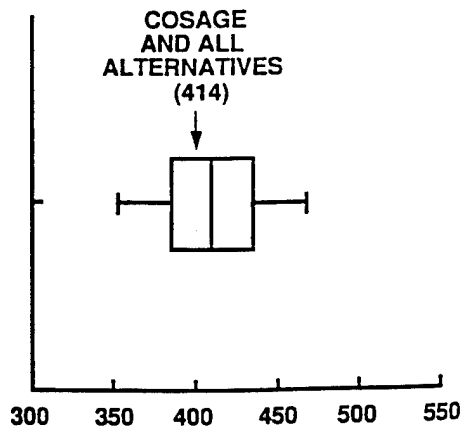

Figure 2-7. MLRS Expenditures - 36 MLRS

c. Figure 2-8 shows the box and whisker plot developed from 10 COSAGE replications for expenditures based on a MLRS density of 1. The current ATCAL extrapolation method produces a value outside of the 10 values that comprise the box and whisker plot. Each of the alternative ATCAL methodologies, however, extrapolates to a value within the range of the box and whisker plot.

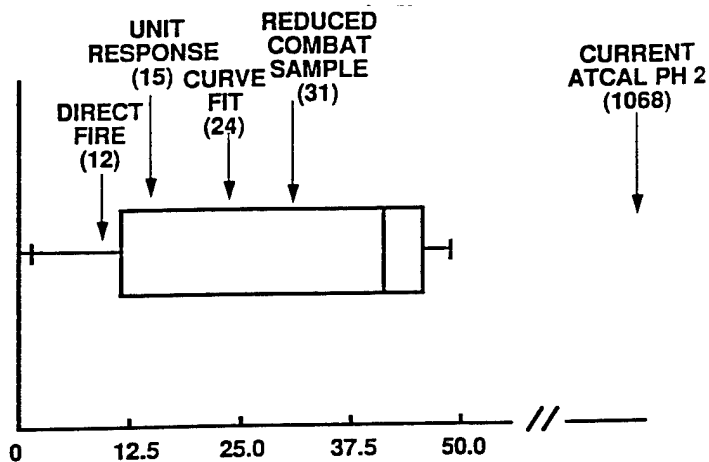

Figure 2-8. MLRS Expenditures - 1 MLRS

CHAPTER 3

OBSERVATIONS

3-1. GENERAL. This study examines indirect fire as portrayed by the ATCAL process. The study effort focuses on two approaches to examining indirect fire. The first approach is research oriented and involves comparing the results of tactical-level simulations to the theater results derived using the ATCAL process. The second approach is analytically oriented and consists of the examination of the equations that make up the indirect fire ATCAL algorithms.

3-2. OBSERVATIONS AND CONCLUSIONS

a. The results of both the Fort Sill artillery model, TAFSM, and CAA's tactical-level model, COSAGE, are examined to determine if a functional relationship exists between shooter density and rounds expended. This study proves that a direct functional relationship exists between shooter density and total rounds expended.

b. From a base case set of calibration parameters, ATCAL is used to extrapolate to varying shooter densities. These results are compared to the observed results from the tactical-level model to determine how well ATCAL extrapolates using the base case calibration parameters. ATCAL is not able to replicate the functional relationship seen in the tactical-level models and accepted as current doctrine.

c. The current indirect fire algorithms are target-dependent. The addition of the average shooter density to the current equations modifies the ATCAL process and more closely replicates the observed indirect fire functional relationship. This method tends to overcompensate its extrapolation; for increasing shooter densities the rounds expended are greater than the observed results from the tactical-level simulation. The converse is true for decreasing shooter densities.

d. A curve fitting parameter can be developed which is based on a specific weapon system. This curve fitting parameter, in the ATCAL algorithms, replicates the tactical-level simulation's functional relationship. It improves upon the average density approach by dampening the expenditures as ATCAL extrapolates to varying shooter densities. The drawback to this method is that the indirect fire algorithms, used for all indirect fire systems, are being modified with a curve fitting parameter which is based on a specific weapon system.

e. In addition to being target-dependent, indirect fire expenditures are also a function of the number of shooters. The direct fire algorithms in ATCAL are already target- and shooter-dependent. Utilizing these equations to develop the indirect fire expenditures yields results consistent with the functional relationship observed from the tactical-level simulation. This approach, however, tends to overcompensate even more than the average density method. Additionally, the productivity of the weapon systems is inconsistent with that observed in the tactical-level simulation. The advantage this method has is its simplicity in its application.

f. Existing theater-level models utilize a 12-hour period as the standard cycle. It has been shown that each method, including the current method, is capable of replicating results for 12 hours--providing that the system densities remain constant between tactical and theater level. However, in comparing a 48-hour tactical level simulation with 48 hours of theater simulation (four theater cycles), the current process does not provide similitude. Similitude is currently obtained only when all systems are treated as direct fire in the ATCAL process.

g. The change to the ATCAL code to implement any of these methodologies is simple and the cost is minimal. Most of the cost will be attributed to time spent to study the impact any of these changes have on theater modeling.

3-3. RECOMMENDATIONS

a. Indirect fire equations in ATCAL need to be modified to reflect current doctrine. There are three methodologies which warrant further investigation:

(1) Including average number of shooters in the Phase I (response) and the Phase II (rounds) equations.

(2) Using the curve fitting technique to modify the current indirect fire equations.

(3) Using the direct fire algorithms to extrapolate for both direct and indirect fire systems.

b. Examine the impact each of the proposed methodologies has on theater-level modeling.

c. Examine if ATCAL should be calibrated to the theater-level time period (currently 12 hours), to the tactical-level time period (48 hours), or to some other time period.

APPENDIX A
STUDY CONTRIBUTORS

1. STUDY TEAM

a. Study Director

Mr. Neal W. Siegel, Force Evaluation Directorate

b. Team Members

MAJ Henry S. Ostapiej
Mr. David Stiger

c. Other Contributors

Mr. R. Glenn Stockton
Mr. Hugh W. Jones
Mr. William T. Allison
Mr. Ron Bonniwell
Mr. Richard Cobb
MAJ Robert C. Glenn, Jr.

2. PRODUCT REVIEW BOARD

Mr. Ronald J. Iekel, Chairman
Ms. Linda A. Coblentz
CPT Karen D. Tomlin

APPENDIX B

STUDY DIRECTIVE



REPLY TO
ATTENTION OF:

CSCA-FOT/TAC

DEPARTMENT OF THE ARMY
US ARMY CONCEPTS ANALYSIS AGENCY
8120 WOODMONT AVENUE
BETHESDA, MARYLAND 20814-2797



01 AUG 1991

MEMORANDUM FOR ASSISTANT DIRECTOR, FORCES DIRECTORATE

SUBJECT: Study Directive - ATCAL Evaluation Phase II (ATVAL II)

1. **PURPOSE.** This directive provides guidance for the Tactical Force Branch to examine the indirect fire portion of the Attrition Calibration Model (ATCAL) and to determine how well it is performing.
2. **BACKGROUND.** U.S. Army Concepts Analysis Agency (CAA) depends upon Attrition Model Using Calibrated Parameters (ATCAL) results for many studies having a wide-ranging impact on Army programs. An initial study of Attrition Model Using Calibrated Parameters (ATCAL) ATCAL Extrapolation I (ATVAL I) was performed with respect to ATCAL's ability to extrapolate for direct fire systems. It is believed that a follow-on study could provide insight into the capability and sensitivity of the indirect fire applications.
 3. **STUDY PROPONENT.** Director, U.S. Army Concepts Analysis Agency.
 4. **STUDY AGENCY.** Tactical Force Branch, Forces Directorate.
 5. **TERMS OF REFERENCE.**
 - a. **Objective.** Examine indirect fire logic in ATCAL to determine its capabilities and limitations. Test indirect fire systems in ATCAL to determine model sensitivities and to examine the range over which they apply. Compare ATCAL extrapolations to historical data and to model outputs from various centers and/or schools.
 - b. **Scope.** This study will have two main focuses, both of which center around artillery issues. The first is research oriented and involves examining other models, recording historical trends and interviewing experts. Data yielded from this phase will be compared to ATCAL artillery generated results. The second focus is analytically oriented and involves using Phase I and Phase II to examine the limitations of ATCAL. Army Integrated Mobilization Study (AIMS 99), Combat Sample Generator (COSAGE) boards will be used as the base case.
 - c. **Miscellaneous.** Detail any improvements to ATCAL which could improve its portrayal of indirect fire.

CSCA-FO

SUBJECT: Study Directive - ATCAL Evaluation Phase II (ATVAL II)

01 AUG 1991

6. RESPONSIBILITIES.

a. Force Directorate (FO).

- (1) Conduct the study.
- (2) Analyze division and theater results.
- (3) Provide the study proponent with progress reports and emerging results.
- (4) Provide as a final report and analysis of items as found in paragraph 5 above: TERMS OF REFERENCE.

b. Research and Analysis Support Directorate (RS): Provide ATCAL assistance as required.

c. Model Validation Directorate (MV): Provide insight into historical usage/trends of artillery munitions.

d. Requirements Directorate (RQ): Provide insight into historical usage/trends of artillery munitions.

7. REFERENCES.

- a. CAA-SR-91-10, July 1991, ATVAL I.
- b. AR 5-5, 15 October 1981, subject: The Army Study System.
- c. AR 10-38, 1 February 1981, subject: Organization and Functions, U.S. Army Concepts Analysis Agency.
- d. Study Director's Guide, U.S. Army Concepts Analysis Agency, May 1986.

8. ADMINISTRATION.

Milestones:

Study Directive/Study Plan ARB	17 Jul 1991
Complete Research on Indirect Fire	27 Sep 1991
First IPR	2 Oct 1991
Complete COSAGE excursion runs	6 Nov 1991
Second IPR	7 Nov 1991
Examine Phase II Sensitivities	5 Dec 1991
Third IPR	12 Dec 1991
Analysis Results ARB	9 Jan 1992
Complete Study Report	9 Feb 1992

CSCA-FO
SUBJECT: Study Directive - ATCAL Evaluation Phase II (ATVAL II)

01 AUG 1991

9. CONTROL PROCEDURES. CAA Form 59 (Study Scheduling Report) is attached as Encl 1. Both the study directive and study plan (Encl 2) have been coordinated with RS and MV directorates.



E. B. VANDIVER III
Director

2 Encls

APPENDIX C
BIBLIOGRAPHY

DEPARTMENT OF THE ARMY

Department of the Army Publications

US Army Concepts Analysis Agency (CAA)

Attrition Calibration (ATCAL) Evaluation Phase I - Direct Fire (ATVAL PHASE I), CAA-SR-91-10, July 1991.

ATCAL: An Attrition Model Using Calibrated Parameters, CAA-TP-83-3, August 1983.

Wartime Requirements for Ammunition, Materiel, and Personnel (WARRAMP); Volume V, Combat Sample Generator (COSAGE) User's Manual, CAA-D-81-2, October 1982.

Combat Sample Generator (COSAGE) Input Data, CAA-D-87-1, March 1987.

US Army Field Artillery School (FAS)

Target Acquisition Fire Support Model (TAFSM), Draft, 1991.

APPENDIX D

CURRENT ATCAL INDIRECT FIRE EXPENDITURE EQUATIONS

There are two phases to the ATCAL process. In Phase I the calibration parameters are calculated from COSAGE results. The three indirect fire calibration parameters are response, lethality, and bias. These parameters are passed to Phase II, where they are used in the calculation of munition expenditures. Looking at Phase II first, the number of rounds expended is a function of the variables shown below.

The total rounds expended is a function of two of the calibration parameters: response and lethality (kills/round) which were passed from Phase I. Importance and average number of targets are internal calculations to Phase II. ATCAL Phase II calculates the number of rounds expended by a shooter from the following equation:

$$(ROUNDS)_i = (RSPNS)_i * L_{ijk} * (IM)_k * \bar{N}_k \quad \text{Phase II}$$

where:

i is the vehicle type

j is the weapon type on the vehicle

k is the target type

$(ROUNDS)_i$ is the total rounds fired in the theater engagement

$(RSPNS)_i$ is a calibration parameter calculated from the COSAGE statistics in ATCAL Phase I (equation shown below)

$$(RSPNS)_i = \frac{(ROUNDS)_{ij}}{P_{ijk} * (IM)_k * \bar{N}_k} \quad \text{Phase I}$$

L_{ijk} is the lethality calibration parameter calculated in ATCAL Phase I

$(IM)_k$ is the potential kill the shooter saves on its side by eliminating its opponents

\bar{N}_k is the average density of the target

$(ROUNDS)_{ij}$ are the total rounds expended in COSAGE

P_{ijk} is kills per round

Although the current formulation of the ATCAL indirect fire algorithm does not mimic the functional relationship seen in the tactical-level simulations, it does follow the intent of the original design. Detailed discussion is available in CAA Technical Paper, ATCAL: An Attrition Model Using Calibrated Parameters (CAA-TP-83-3).

APPENDIX E
INFORMATION PAPER ON RESPONSE FACTOR

The following information paper was written by MAJ Robert C. Glenn, Jr. (USAR) as a part of his active duty obligation. This paper discusses the effects of changing the response factor, in ATCAL Phase II, in an attempt to effect total rounds expenditure, at the theater level, without rerunning COSAGE.

(THIS PAGE INTENTIONALLY LEFT BLANK)

INFORMATION PAPER

CSCA-FOT/TAC

25 July 1991

SUBJECT: Development of an algorithm for adjusting ATCAL input to Phase II in CEM (Concepts Evaluation Model) so as to affect an increase in kills for artillery indirect fire units.

BACKGROUND:

A study that uses CEM must use the results of a specific COSAGE force structure. COSAGE is a division level simulation which models tactics and doctrine as accurately as possible. Running COSAGE is a time consuming, manpower intensive process. The COSAGE results are then run through ATCAL (an attrition model using calibrated parameters) Phase I to produce calibrated attrition parameters which are then used as input to ATCAL Phase II, which has been integrated into CEM. The usefulness of CEM is greatly enhanced by being able to do "what if's"; i.e. to say "What if we had twice as many indirect fire artillery systems?", make some changes, run CEM again and compare the results to the previous results without having to rerun the COSAGE model. On one occasion this had been attempted by doubling the number of Multiple Launch Rocket Systems (MLRS) used as input to ATCAL Phase II, however, the number of kills did not increase and in fact the MLRS took more hits since there were more of them. The purposes of this study are to 1) investigate the effect of changing another variable in conjunction with the doubling of the number of MLRS "tubes", 2) and to make recommendations concerning the development and use of an algorithm to selectively increase the number of kills attributed to the MLRS without having to rerun COSAGE and ATCAL Phase I.

TASK DESCRIPTION: A study team has been assembled to investigate the wider application of modifying indirect fire system input to CEM, but for the purpose of this study, the MLRS was chosen as a system for initial analysis. This project builds upon and proceeds collaterally with the efforts of CAA research personnel, Mr. Neal Siegel and MAJ Henry Ostapiej, and involves the following tasks:

- Interview analysts and modelers currently using ATCAL and CEM concerning program operation and variables.
- Select a variable to manipulate in conjunction with the number of tubes.
- Change the variables one at a time and make multiple runs of ATCAL Phase II with different values for the variables.
- Graph the results.
- Analyze the results to see if they lend themselves to a prediction equation.
- Develop forecasting algorithm and graph results.
- Develop recommendations for use of forecasting algorithm.
- Prepare an Information Paper and conduct a briefing of the project.

DISCUSSION: During the interviews with modelers and analysts it was suggested to vary the value of the Response Factor associated with the MLRS. This would in effect modify the number of rounds per demand for the system used in Phase II. Initially the number of tubes was doubled to 72 and the Response Factor multiplied by 1.0, 1.2, 1.4, 1.6, 1.8, and 2.0. Analysis of the results indicated a sharp increase in the number of kills against tanks, APC's, and artillery from level 1.0 to 1.2 and then a gradual increase in kills as the Response Factor was increased. Subsequent runs were done for multipliers of 1.025, 1.050, 1.075, 1.1, 1.25, 1.150, 1.175, 3.0, and 4.0 for

the double quantity (2X) case. See Charts 1-4. Base case runs were also conducted for standard quantity of tubes (36) with Response Factor Multipliers of 1.0, 1.2, 1.4, 1.6, 1.8, and 2.0. See Charts 4-6.

The graphing of the results suggested a linear relationship among the variables of Response Factor and kills. The linear relationship was confirmed by the linear regression analyses with r squared values ranging from .995046 to .99946 for the 72 tube case and from .999253 to .999902 for the 36 tube case. These are extremely high values and indicate that over 99 percent of the variance associated with the data has been accounted for by the analysis. Values for r squared in the range of .6 to .8 are generally considered to be "good". The subsequent plotting of the forecasting lines derived by using the X coefficient and constants from the analyses can be seen on the appropriate charts 1 through 6. Analyses of the charts indicate that whenever the Response Factor is multiplied by a factor greater than 1.0, there is an initial jump from the base level of kills and then a gradual increase with successive increases in the Response Factor Multiplier (RFM). Due to this jump, the base case of RFM = 1.0 was not included in the regression analyses. The relationship between kills and RFM appears to be linear in each case, as well as the relationship between total shots fired and RFM (see Chart 10).

A comparison of the data and regression forecasting lines (Charts 7 through 9) indicates the kill line for the 36 tube case has greater magnitude than for the 72 tube case. Mr. Siegel indicates that this continues the same trend that has been seen in past studies. While this relationship is not correct, it appears to result from an increase in importance for the MLRS (kill/tube) as the quantity increases. This phenomenon is the subject of the CAA ATVAL II study.

CONCLUSION: From this initial study of a single indirect fire system, it appears that there is a way to modify the input to ATCAL Phase II to increase the number of kills without having to rerun COSAGE and ATCAL Phase I. A table was prepared as an example of how the data could be used to modify the MLRS Response Factor (see Table 1). Additional values for situations where the number of tubes were increased to 108 and 144 were extrapolated from the

current data using a percent change methodology. It was noted that as the number of tubes increased the same RFM did not necessarily yield a higher number of kills. To achieve a higher number of kills when the number of tubes increased, the RFM also had to be increased. A branching slide show was also developed using Quattro Pro 2.0, to graphically display the results of the study.

RECOMMENDATIONS: Selected values for the RFM (such as 1.4, 1.8, 2.0, 3.0, and 4.0) should be investigated for number of tubes 108, 144 etc., and regression analyses used to develop forecasting values for kills. These can then be used to develop a table such as Table 1. The results from these analyses should also be run through CEM and the output evaluated to see if the desired results are achieved. As can be seen, there is potential for the development of "What If" tables which could actually be incorporated into ATCAL Phase II as input boards. However, in order to make a change, two values have to be modified. For simple "What If's", such as adding a battery or two of MLRS, or bringing in the reserve indirect fire unit, it maybe feasible to make the changes at these levels; however, a point will be reached where the number of changes required will be so large that it will be more efficient to rerun COSAGE.

ROBERT C. GLENN, JR
Major, IN
29 July 1991

TANK KILLS

2X Quantity (72)

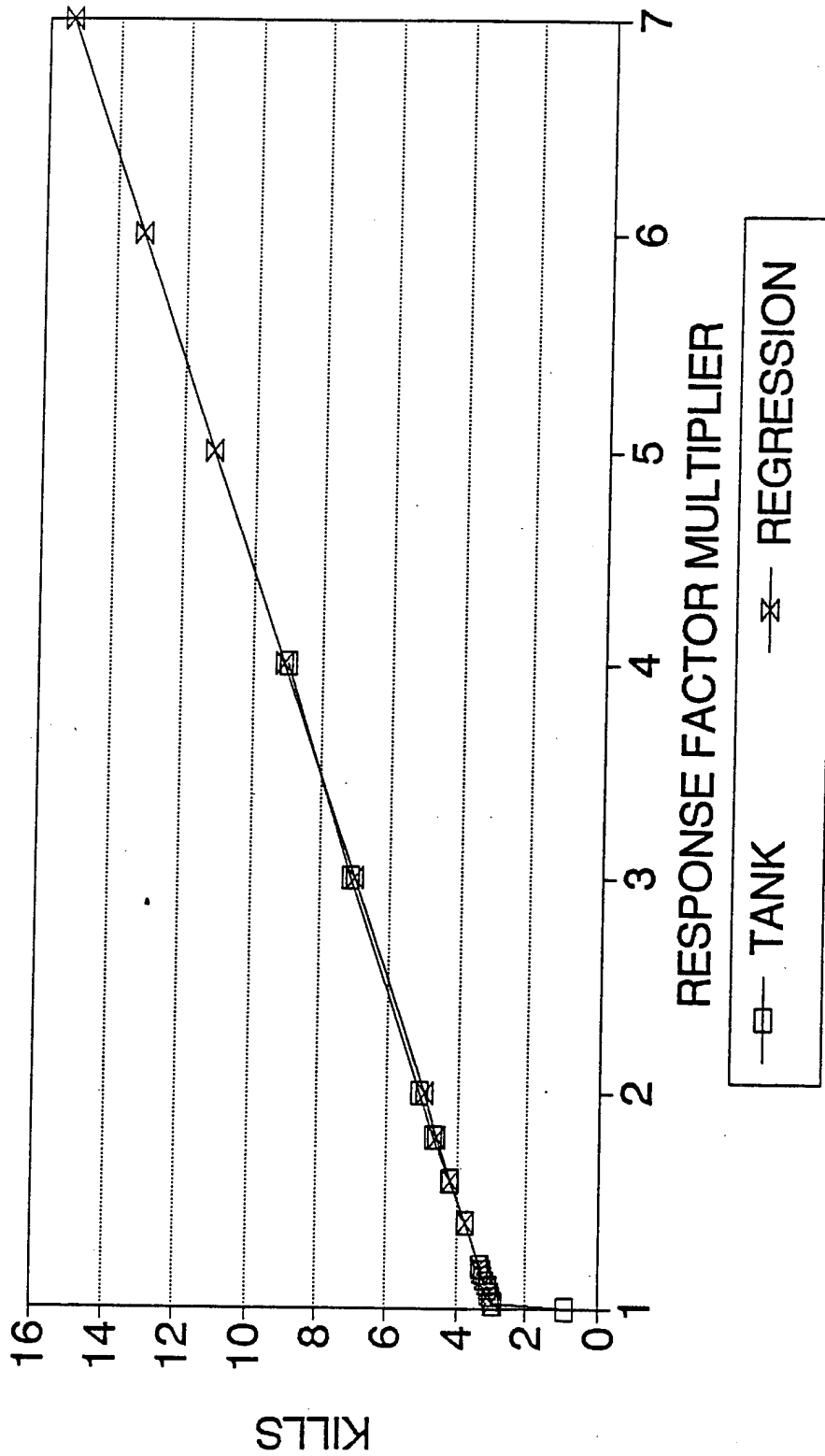

CHART 1

APC KILLS 2X Quantity (72)

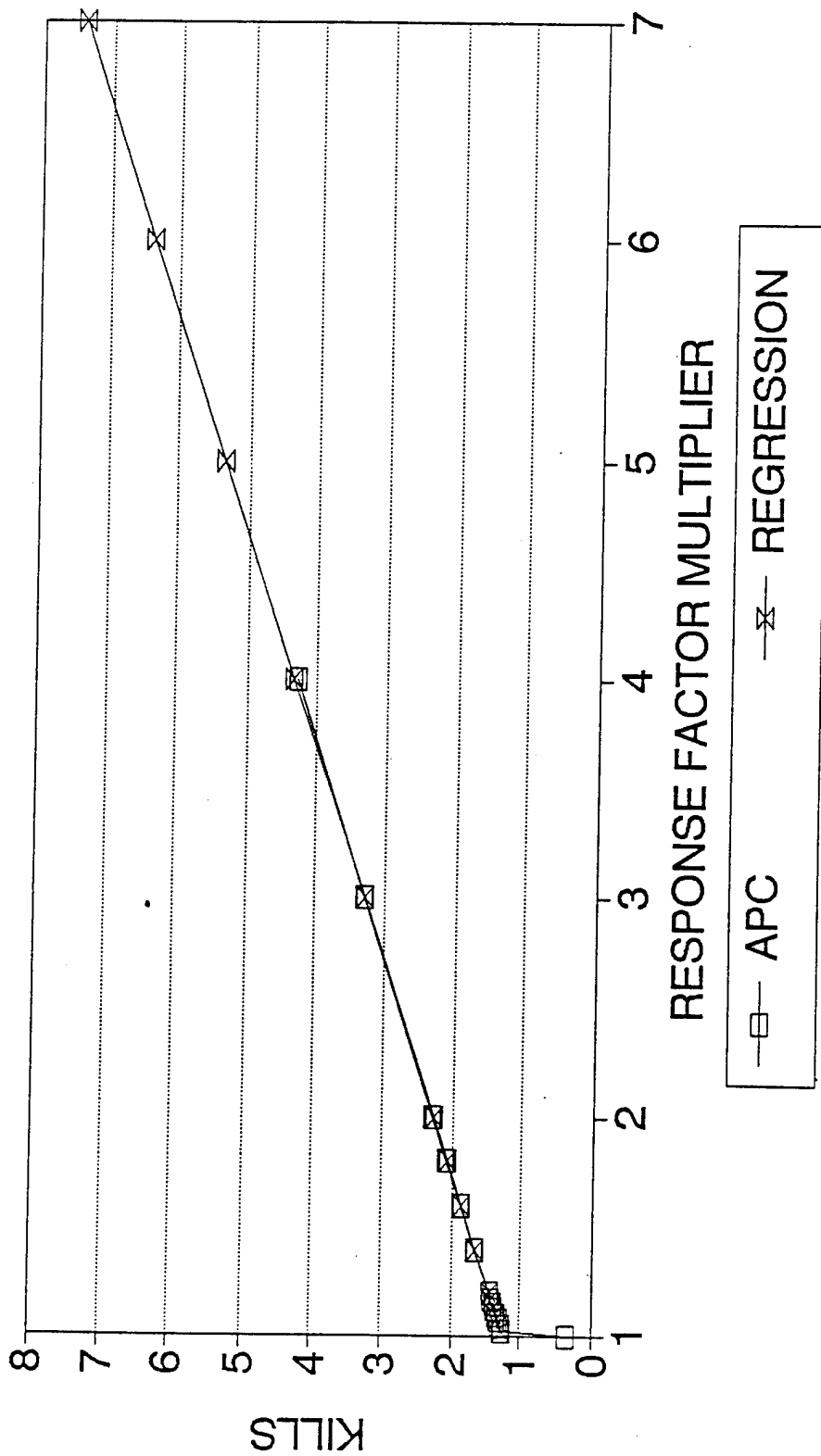

CHART 2

ARTY KILLS 2X Quantity (72)

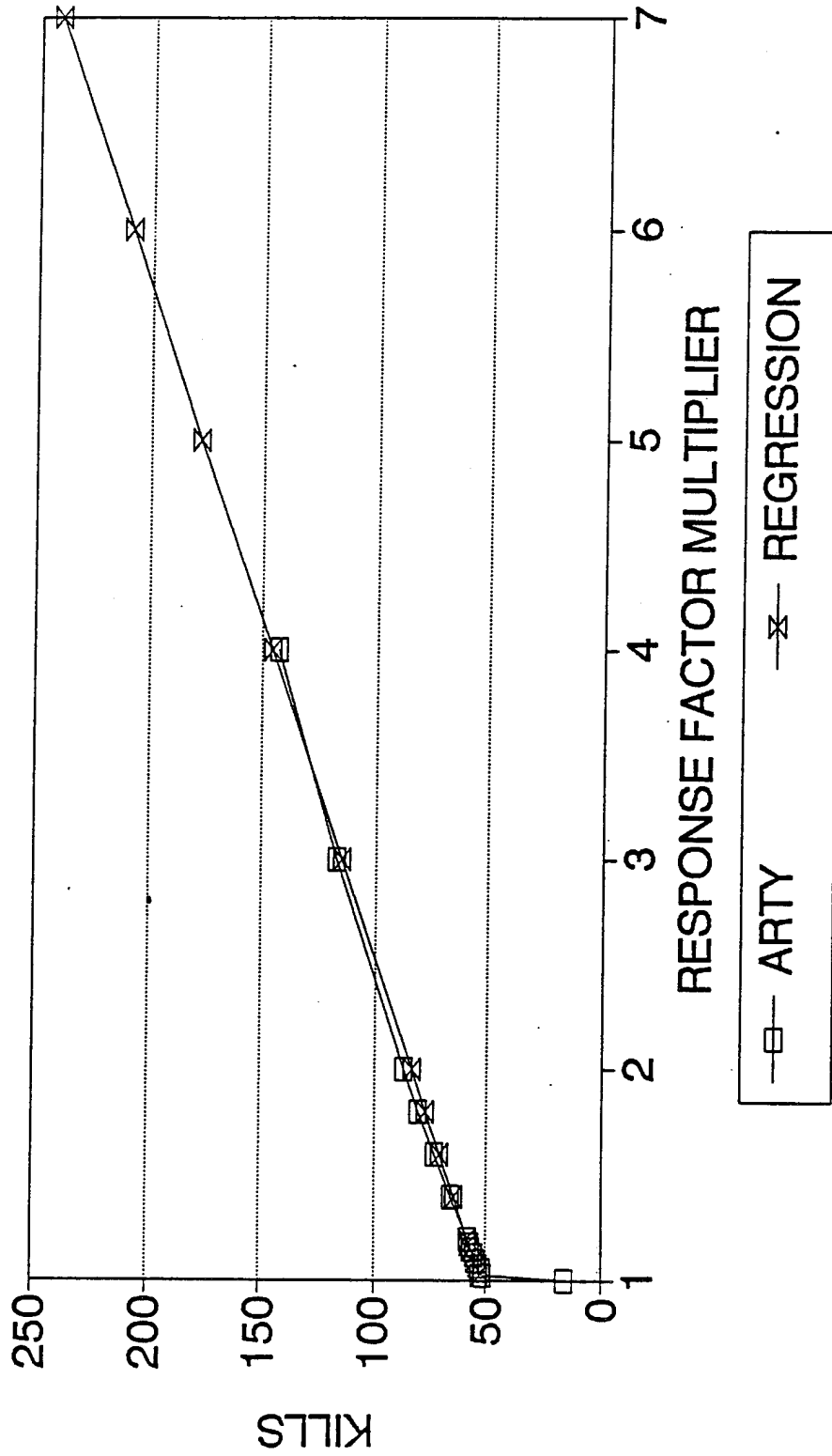

CHART 3

TANK KILLS

Standard Quantity (36)

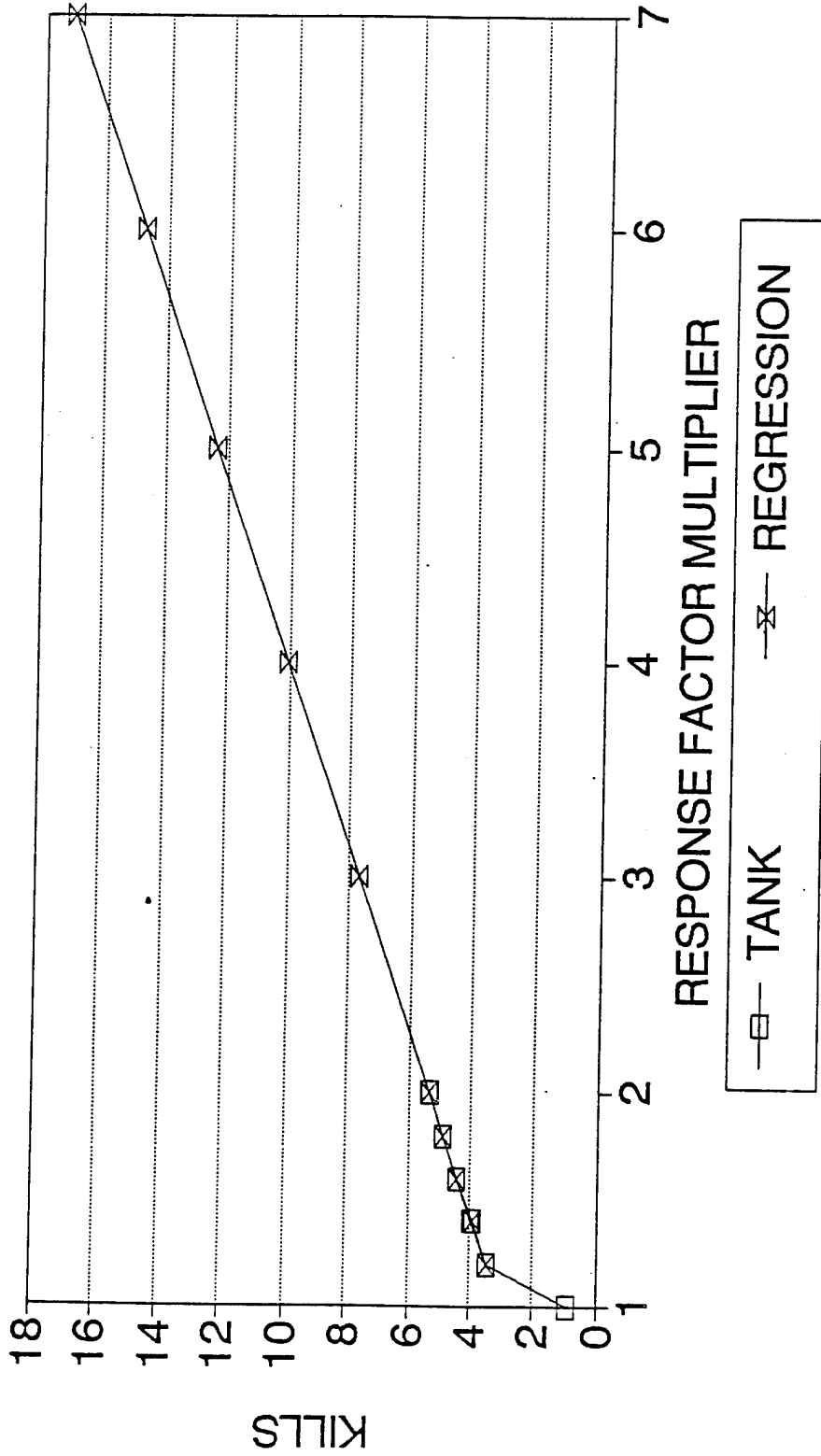

CHART 4

APC KILLS

Standard Quantity (36)

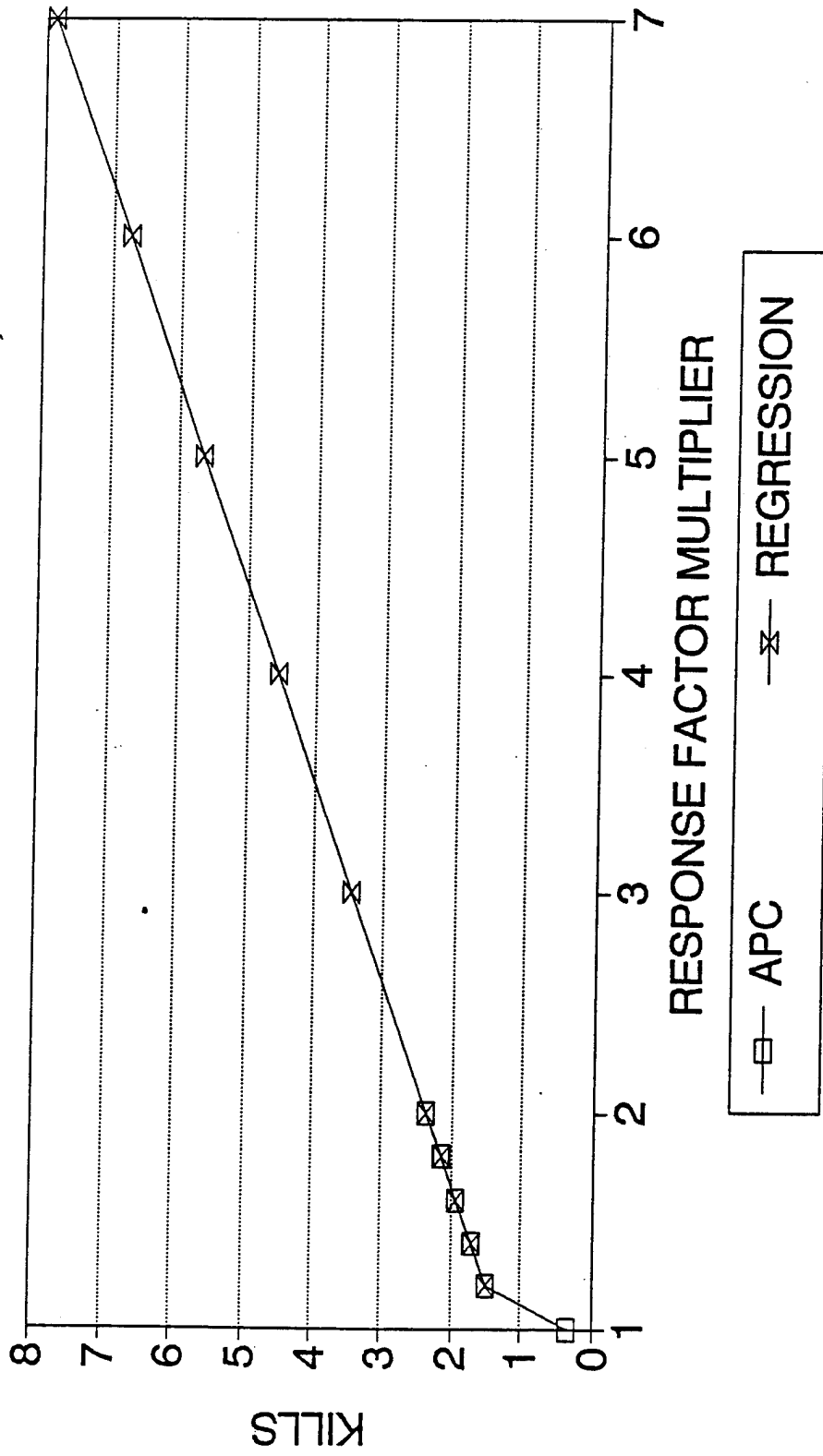

CHART 5

ARTY KILLS

Standard Quantity (36)

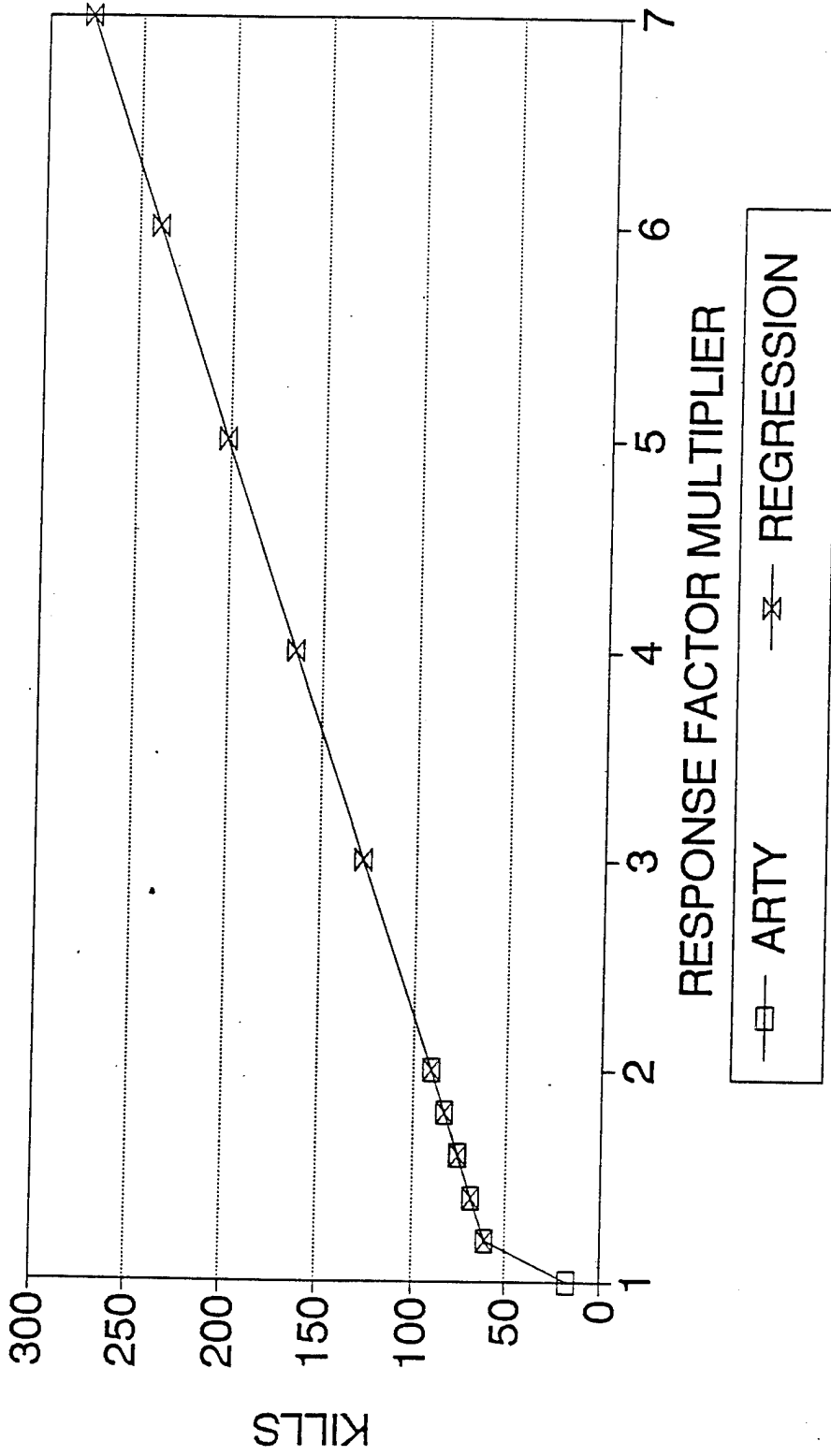

CHART 6

TANK KILLS 36 & 72 Comparison

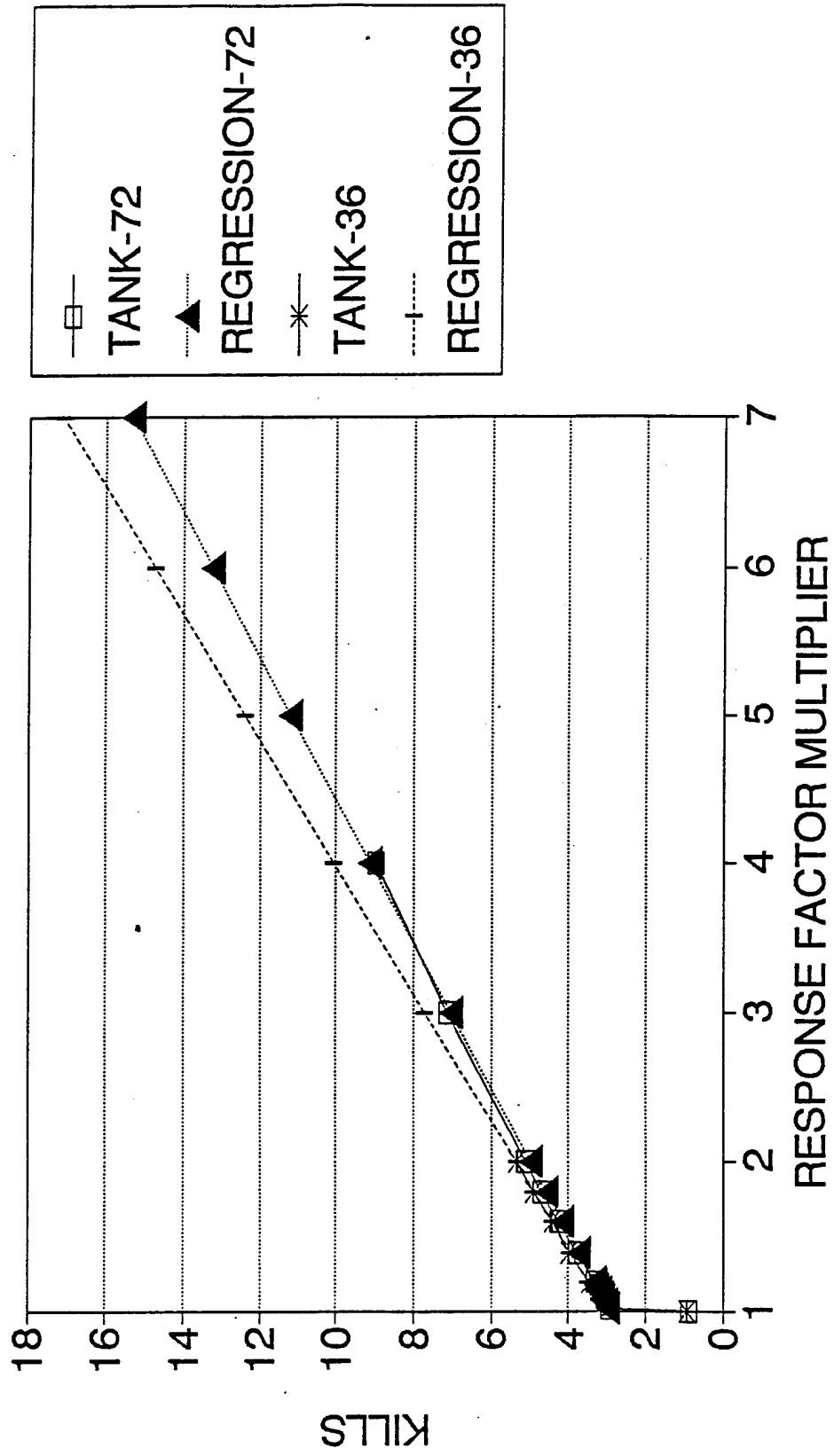

CHART 7

APC KILLS 36 & 72 Comparison

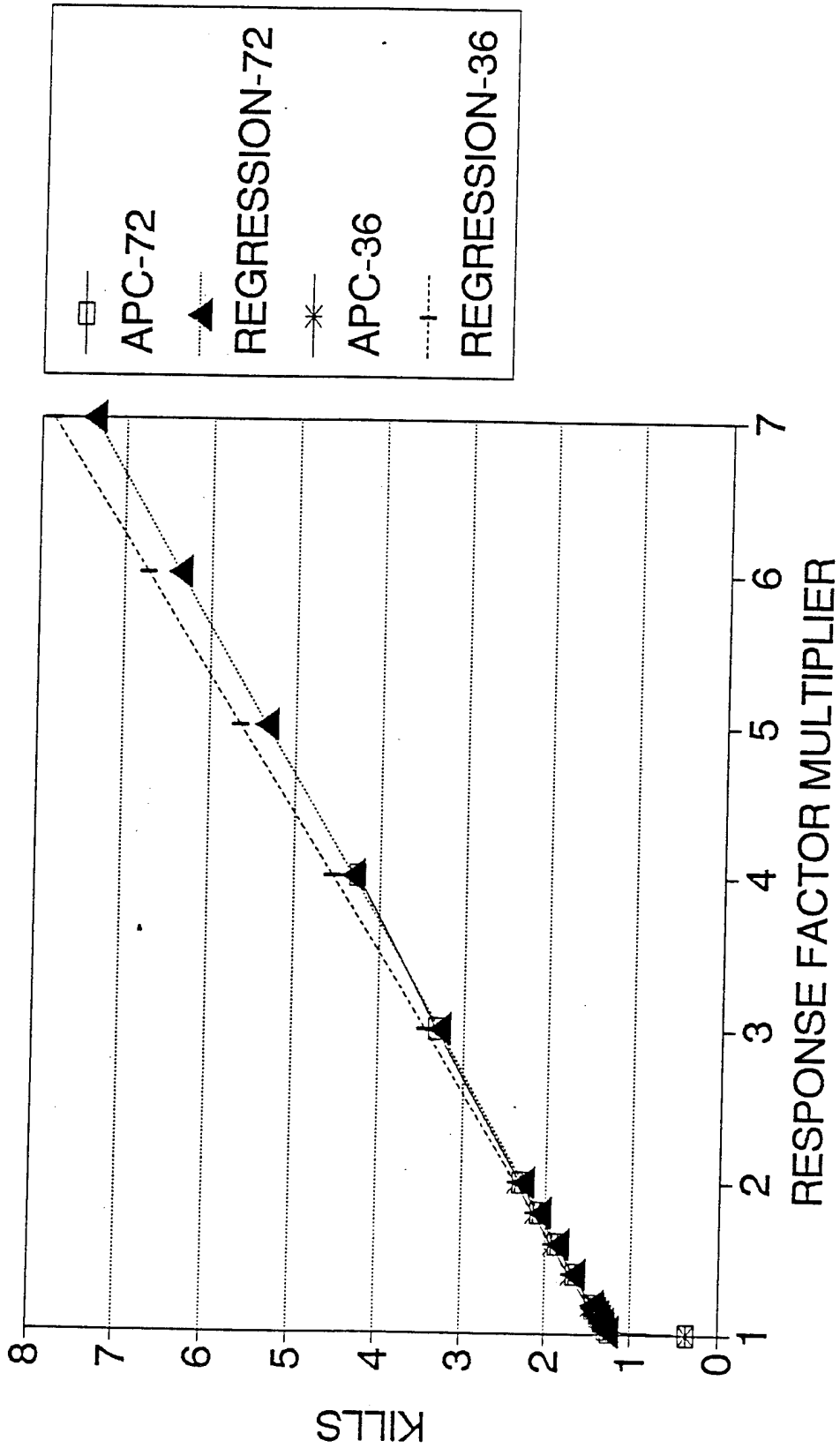

CHART 8

ARTY KILLS 36 & 72 Comparison

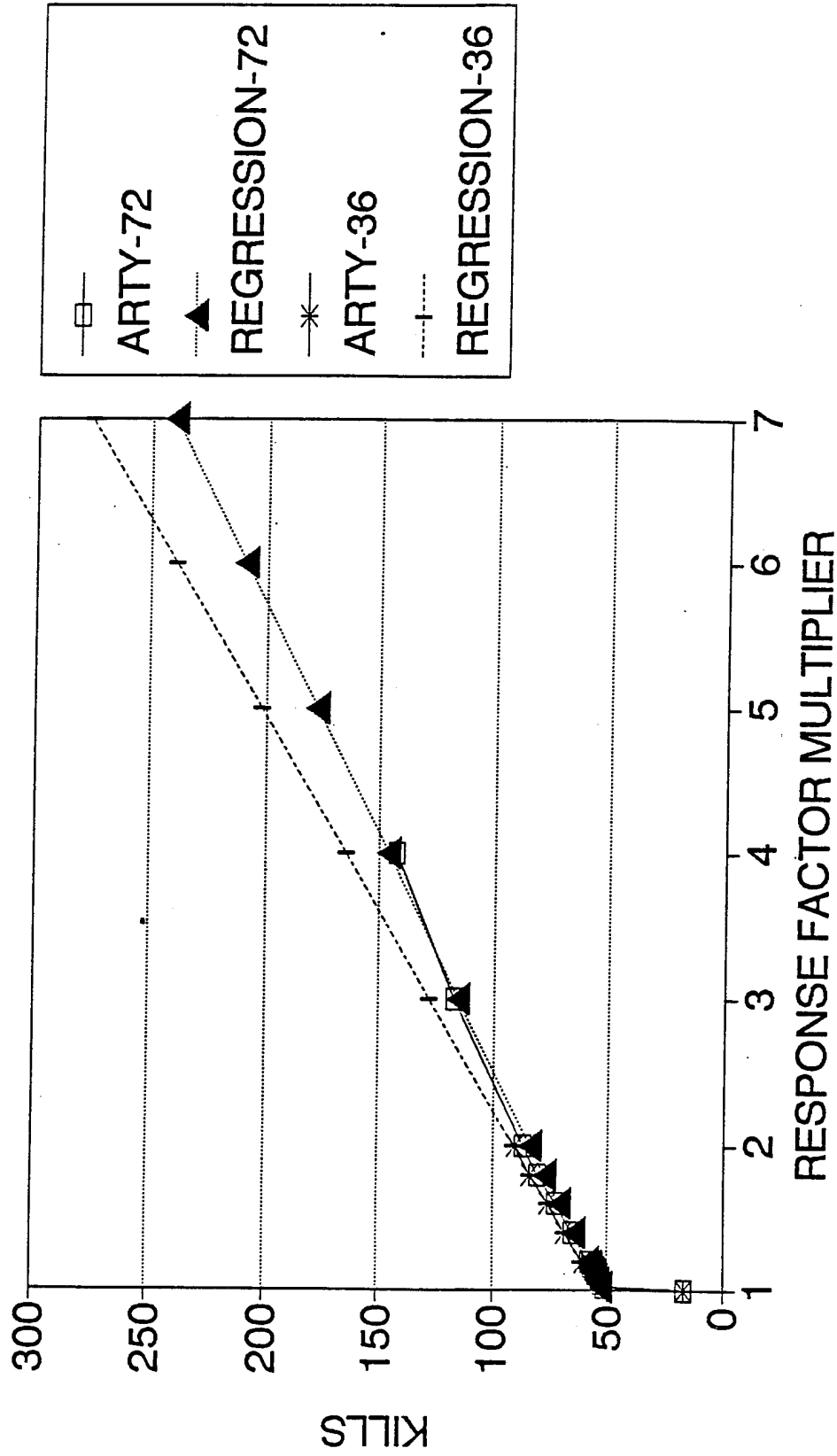

CHART 9

TOTAL SHOTS 36 & 72 Comparison

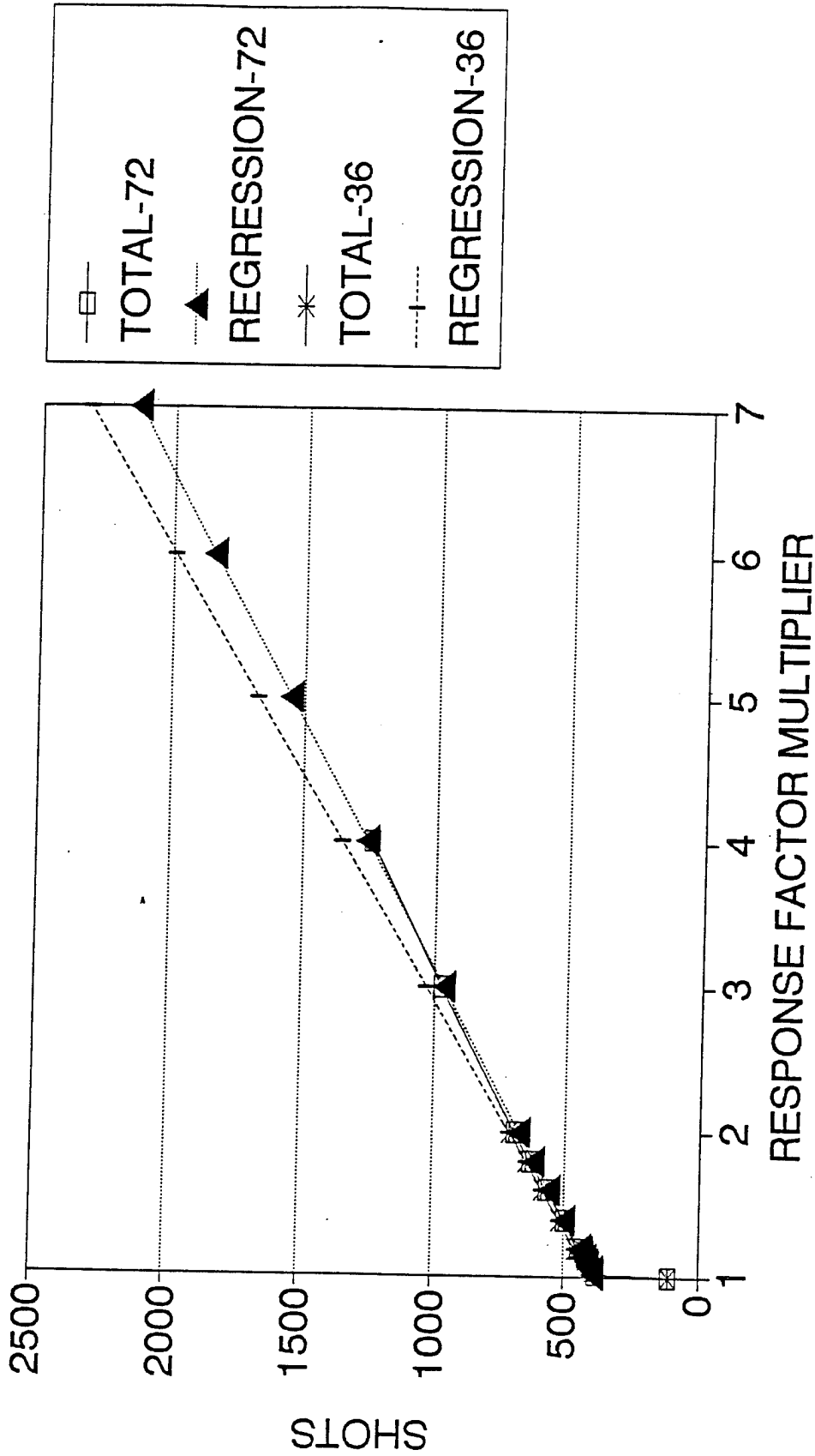

CHART 10

RESPONSE FACTOR MULTIPLIER TABLE

Multiple Launch Rocket System (MLRS) Against Tanks

RFM	Kills 36 Tubes	Kills 72 Tubes	Kills 108 Tubes*	Kills 144 Tubes*
1.1	3.4287594	3.1196103	2.8383352	2.5824208
1.2	3.6633538	3.3261002	3.0198947	2.7418789
1.3	3.8979481	3.5325901	3.2014774	2.9014001
1.4	4.1325425	3.7390800	3.3830793	3.0609738
1.5	4.3671368	3.9455699	3.5646974	3.2205913
1.6	4.6017312	4.1520597	3.7463292	3.3802459
1.7	4.8363255	4.3585496	3.9279727	3.5399321
1.8	5.0709199	4.5650395	4.1096263	3.6996456
1.9	5.3055142	4.7715294	4.2912886	3.8593827
2.0	5.5401086	4.9780193	4.4729585	4.0191403
2.1	5.7747029	5.1845092	4.6546352	4.1789160
2.2	6.0092973	5.3909991	4.8363177	4.3387076
2.3	6.2438916	5.5974889	5.0180055	4.4985134
2.4	6.4784860	5.8039788	5.1996979	4.6583317
2.5	6.7130803	6.0104687	5.3813946	4.8181613
2.6	6.9476747	6.2169586	5.5630950	4.9780009
2.7	7.1822690	6.4234485	5.7447988	5.1378497
2.8	7.4168634	6.6299384	5.9265056	5.2977067
2.9	7.6514577	6.8364282	6.1082153	5.4575712
3.0	7.8860521	7.0429181	6.2899275	5.6174425
3.1	8.1206464	7.2494080	6.4716420	5.7773200
3.2	8.3552408	7.4558979	6.6533586	5.9372032
3.3	8.5898351	7.6623878	6.8350772	6.0970917
3.4	8.8244295	7.8688777	7.0167976	6.2569849
3.5	9.0590238	8.0753676	7.1985197	6.4168826
3.6	9.2936182	8.2818574	7.3802432	6.5767843
3.7	9.5282125	8.4883473	7.5619682	6.7366898
3.8	9.7628069	8.6948372	7.7436945	6.8965989
3.9	9.9974012	8.9013271	7.9254220	7.0565112
4.0	10.2319956	9.1078170	8.1071507	7.2164266

Read down the Kills column to get desired number, then read left to get the RFM to use.

* Extrapolated values using percent change from 36 to 72 tube cases.

TABLE 1

APPENDIX F
BOX AND WHISKER PLOTS

F-1. The individual points for the COSAGE replications are plotted along an axis. The median is determined and a vertical line plotted. A box is drawn around one-quarter of the values to the right of the median and one-quarter of the values to the left of the median. This is called the box (or spread). The whisker portion is initially determined by drawing a line from each end of the box, along the axis, that is one and one-half times the spread. If there is a data point at the end of the whisker, the whisker remains there. If there is no data point there, the whisker is adjusted closer to the box until it reaches a data point. All data points outside of the whiskers are called outliers.

F-2. The following is an example of step by step development of a box and whisker plot.

STEP 1. Plot the individual points along an axis.

* * * * * * * * * * * * *

STEP 2. Determine the median and draw a vertical line.

* * * * * * * * | * * * * * * *

STEP 3. Draw a box around one-quarter of the values to the right of the median and one-quarter of the values to the left of the median.

* * * * * * * * | * * * * * *

STEP 4. Initially determine the whisker portion by drawing a line from each end of the box, along the axis, that is one and one-half times the box. If there is a data point at the end of the whisker, the whisker remains there. If there is no data point there, the whisker is adjusted closer to the box until it reaches a data point.

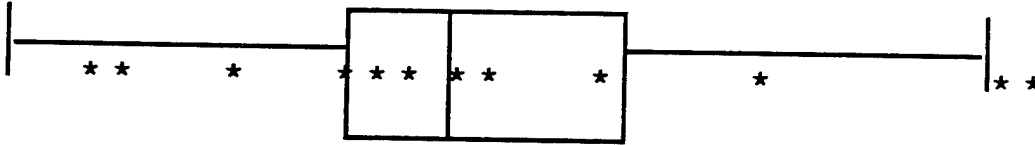

STEP 5. Any data points outside of the whiskers are called outliers.

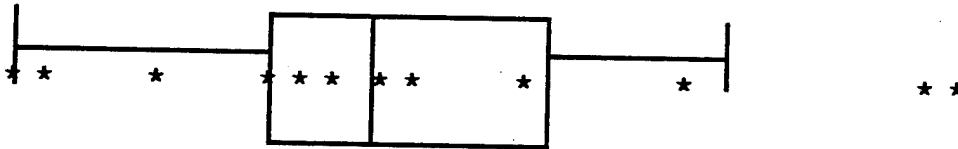

F-3. The following are the box and whisker plots based on the results of the experiments described in Chapter 4.

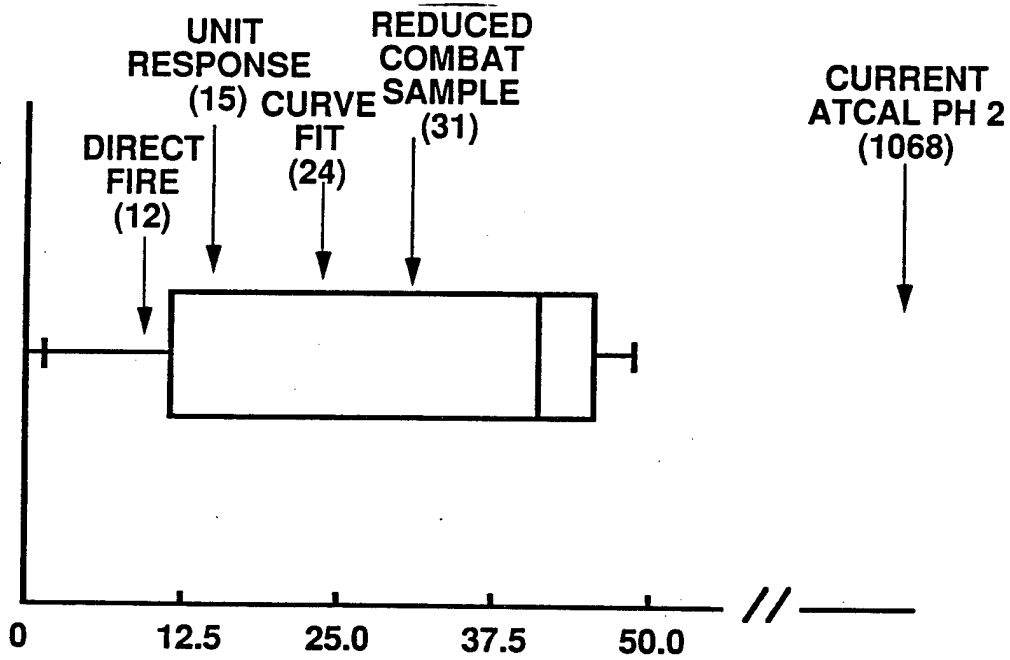

Figure F-1. Total MLRS Expenditures - 1 MLRS

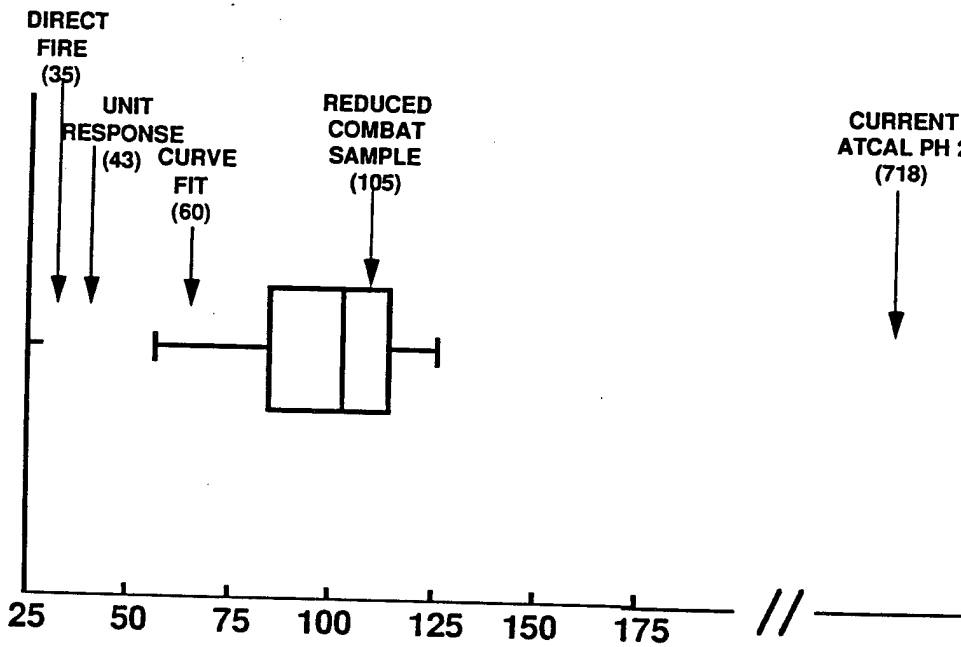

Figure F-2. Total MLRS Expenditures - 3 MLRS

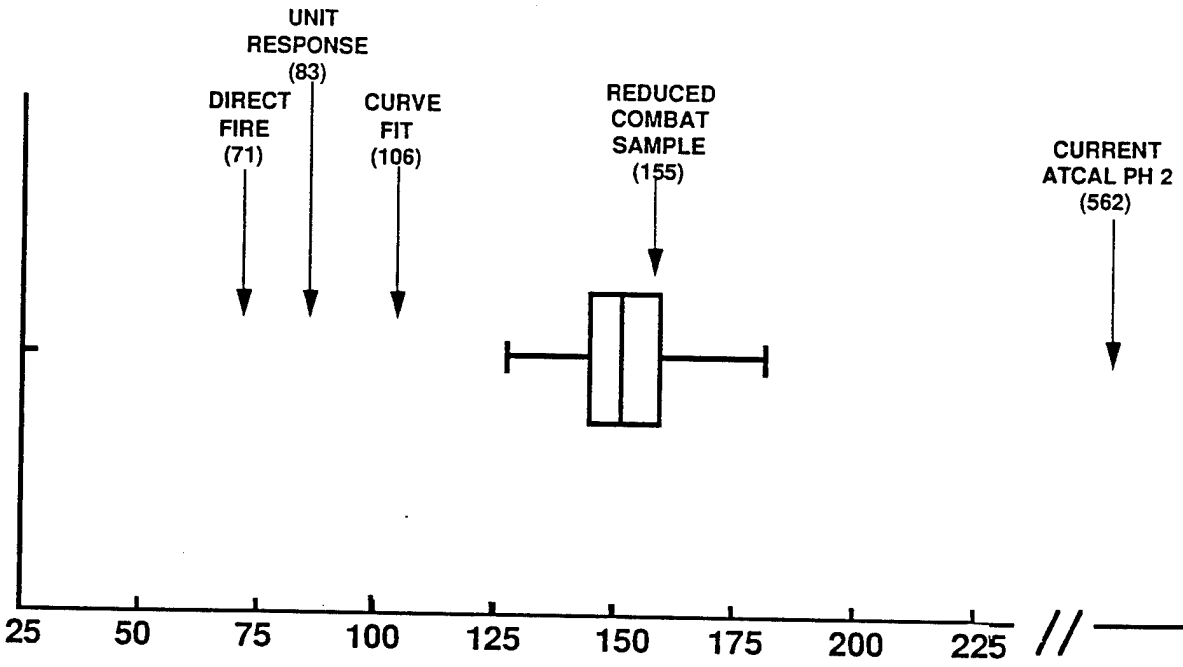

Figure F-3. Total MLRS Expenditures - 6 MLRS

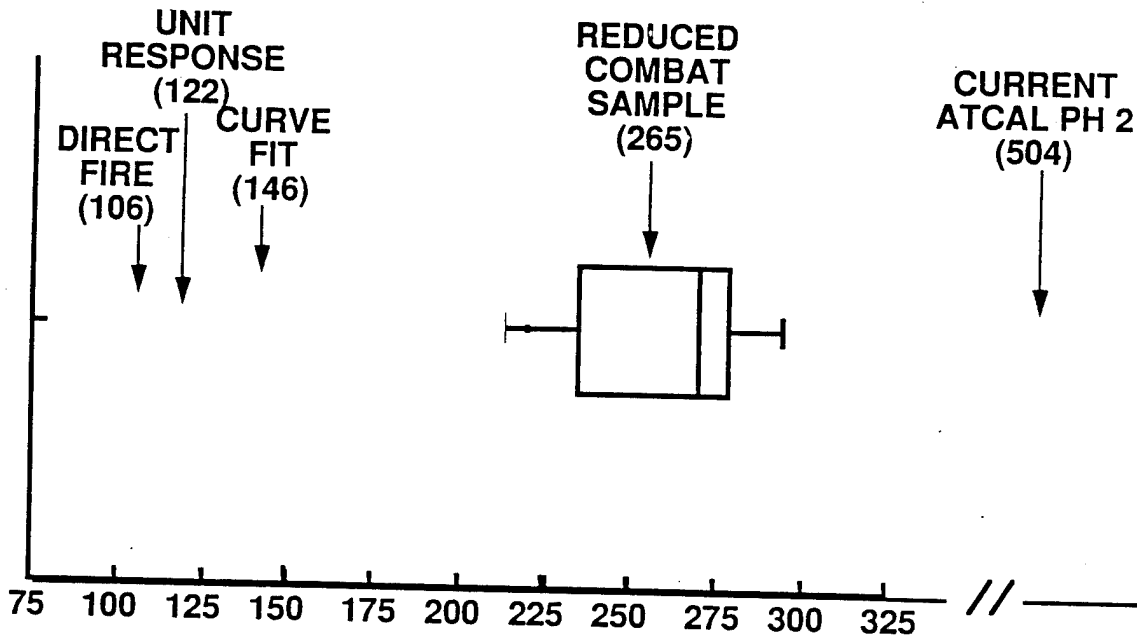

Figure F-4. Total MLRS Expenditures - 9 MLRS

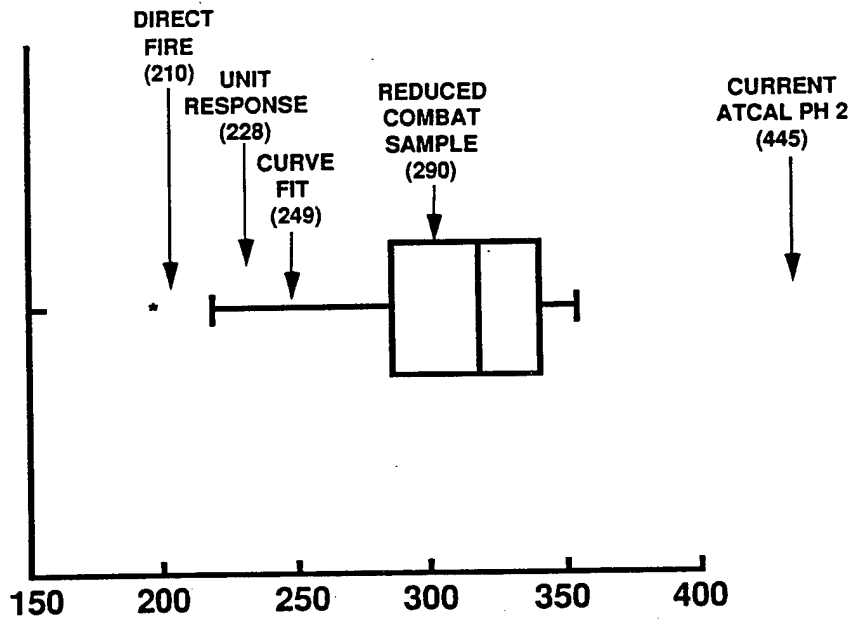

Figure F-5. Total MLRS Expenditures - 18 MLRS

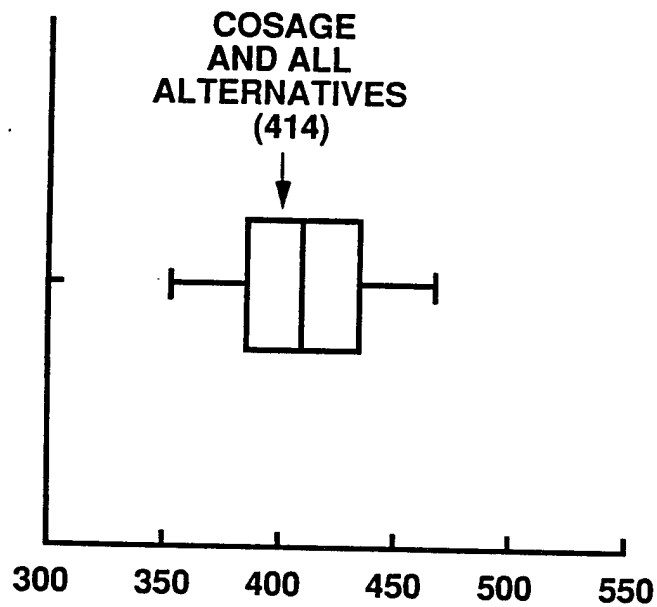

Figure F-6. Total MLRS Expenditures - 36 MLRS

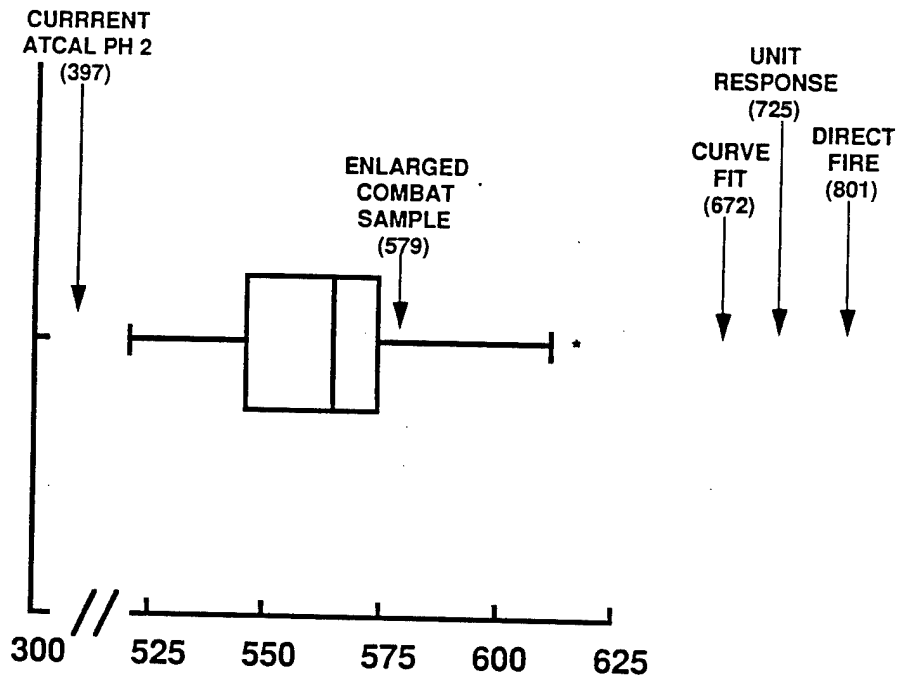

Figure F-7. Total MLRS Expenditures - 72 MLRS

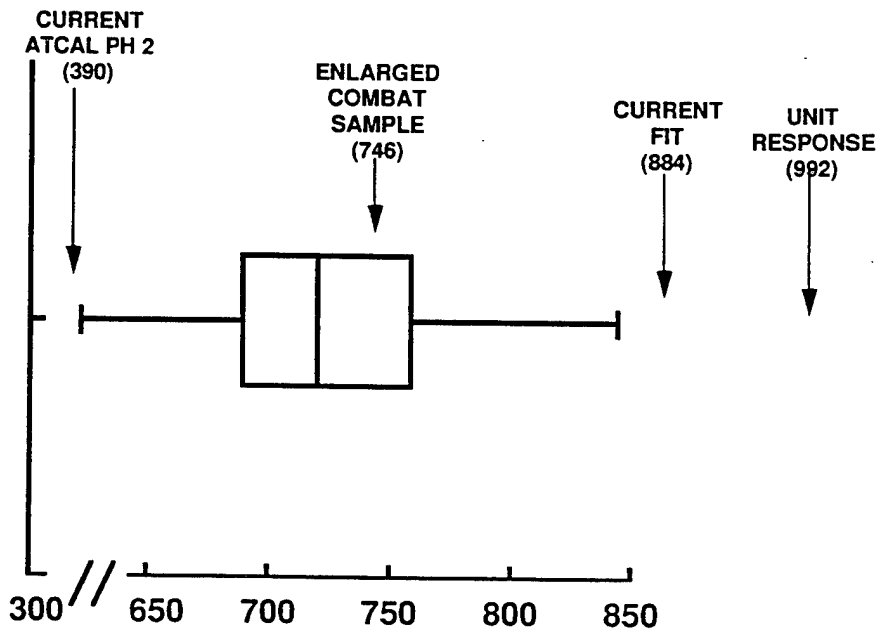

Figure F-8. Total MLRS Expenditures - 108 MLRS

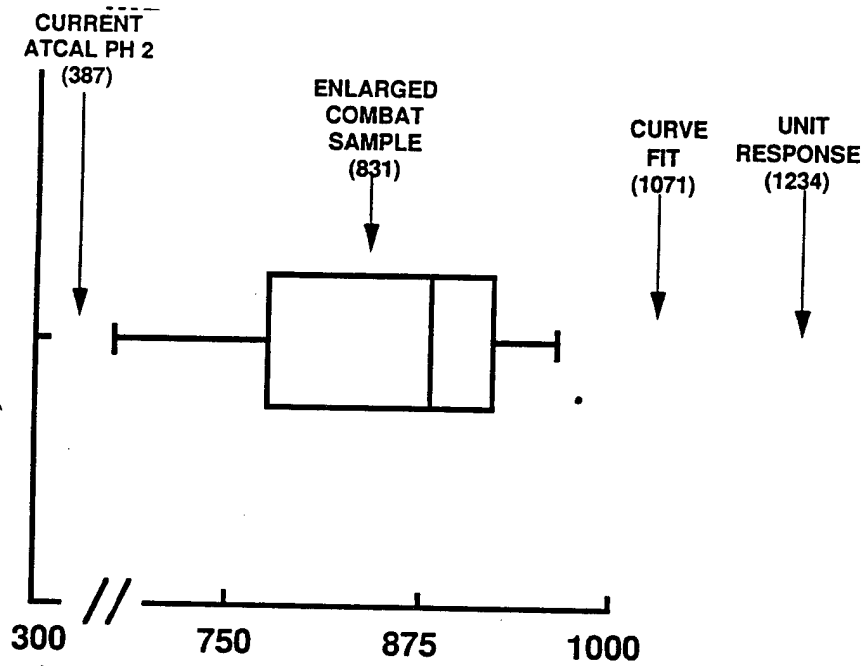

Figure F-9. Total MLRS Expenditures - 144 MLRS

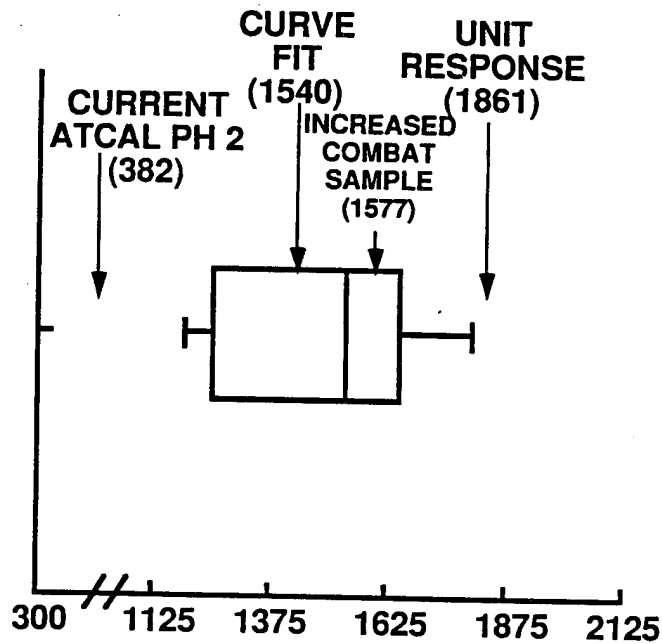

Figure F-10. Total MLRS Expenditures - 252 MLRS

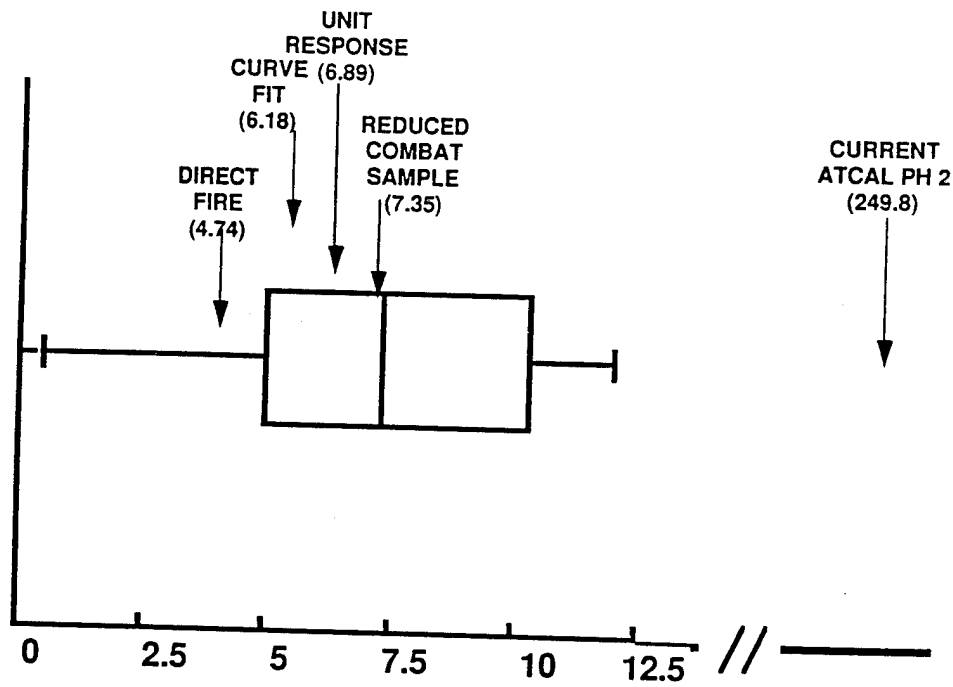

Figure F-11. Total Kills by MLRS - 1 MLRS

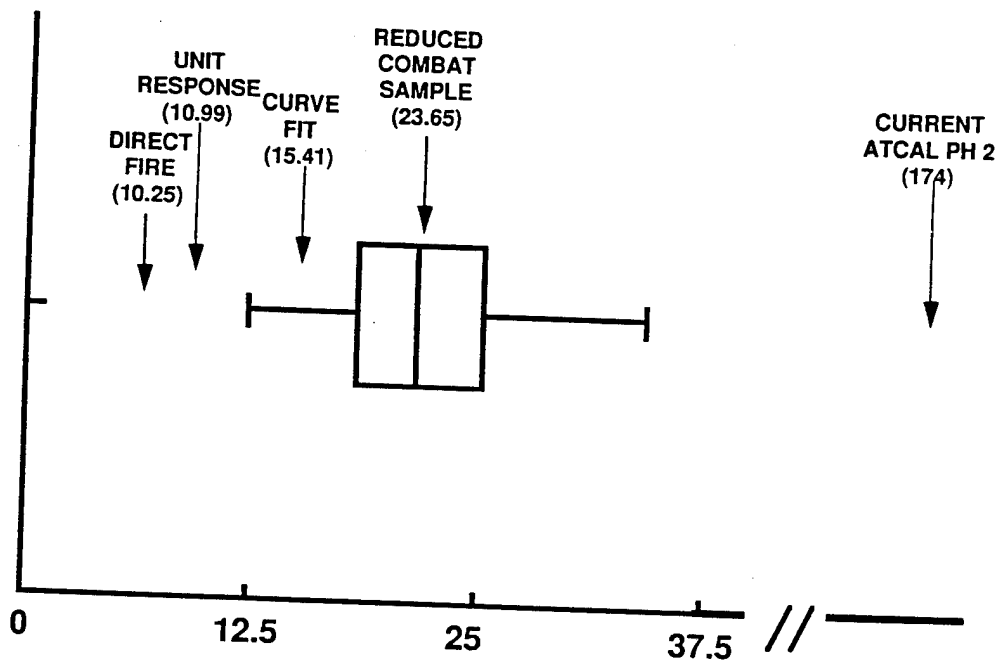

Figure F-12. Total Kills by MLRS - 3 MLRS

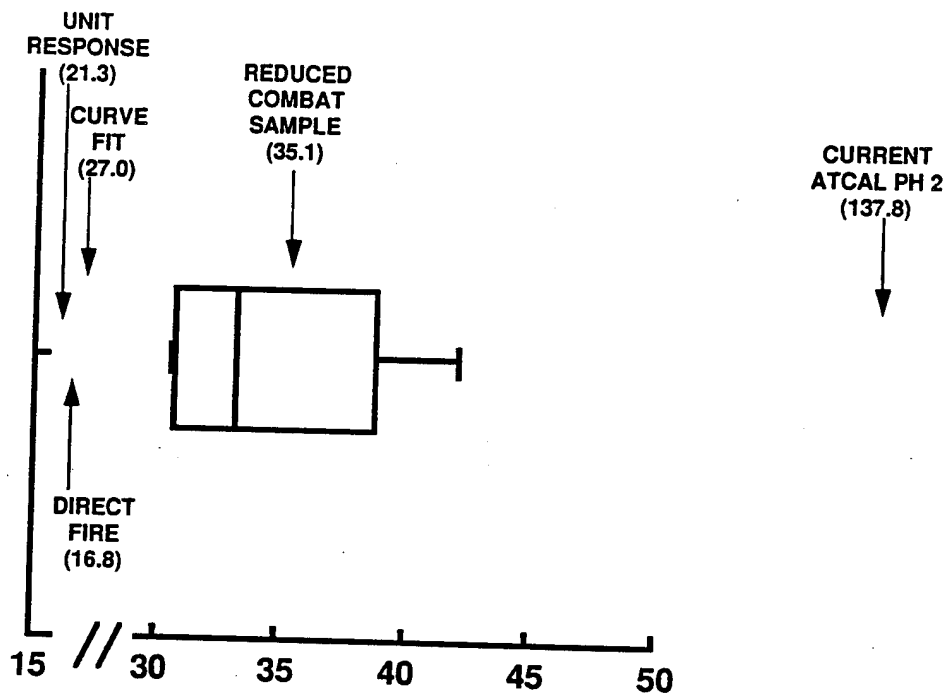

Figure F-13. Total Kills by MLRS - 6 MLRS

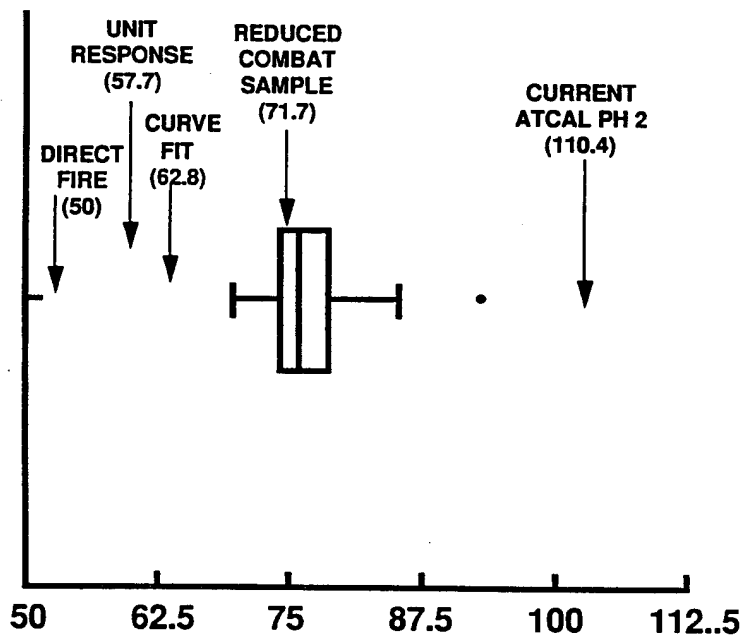

Figure F-14. Total Kills by MLRS - 9 MLRS

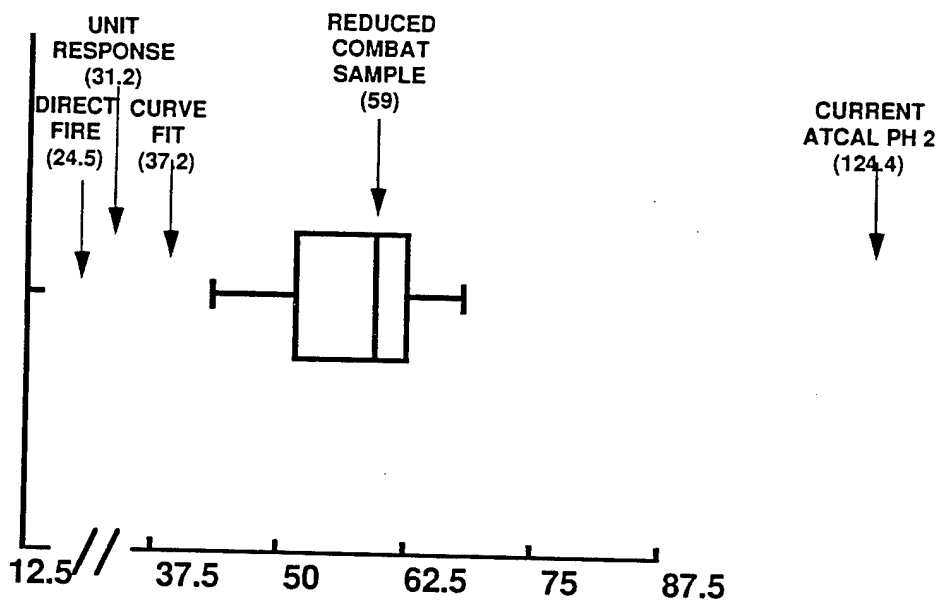

Figure F-15. Total Kills by MLRS - 18 MLRS

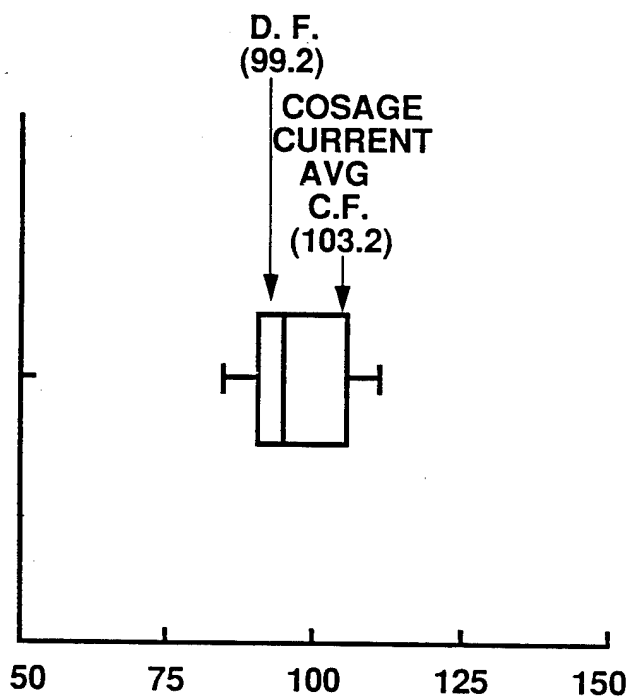

Figure F-16. Total Kills by MLRS - 36 MLRS

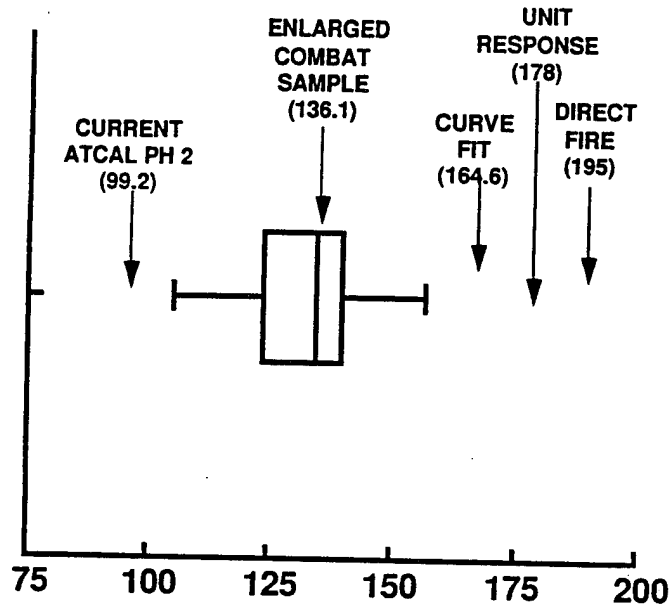

Figure F-17. Total Kills by MLRS - 72 MLRS

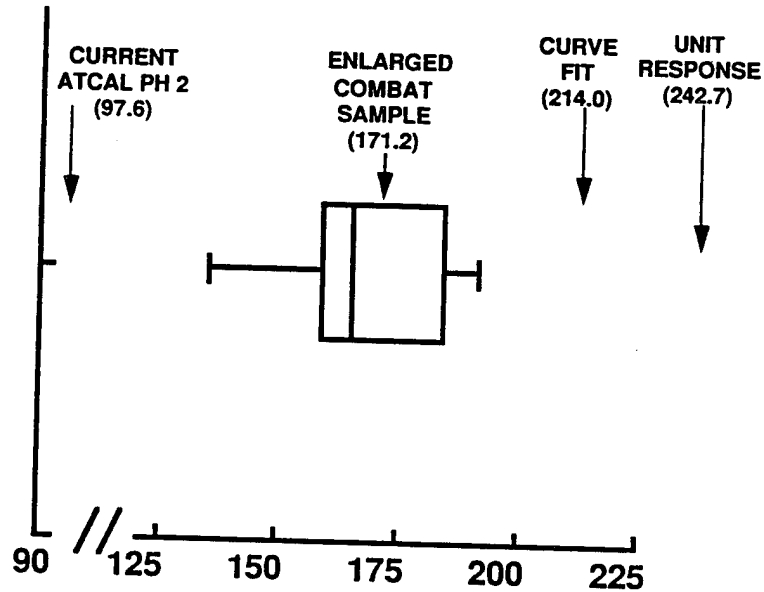

Figure F-18. Total Kills by MLRS - 108 MLRS

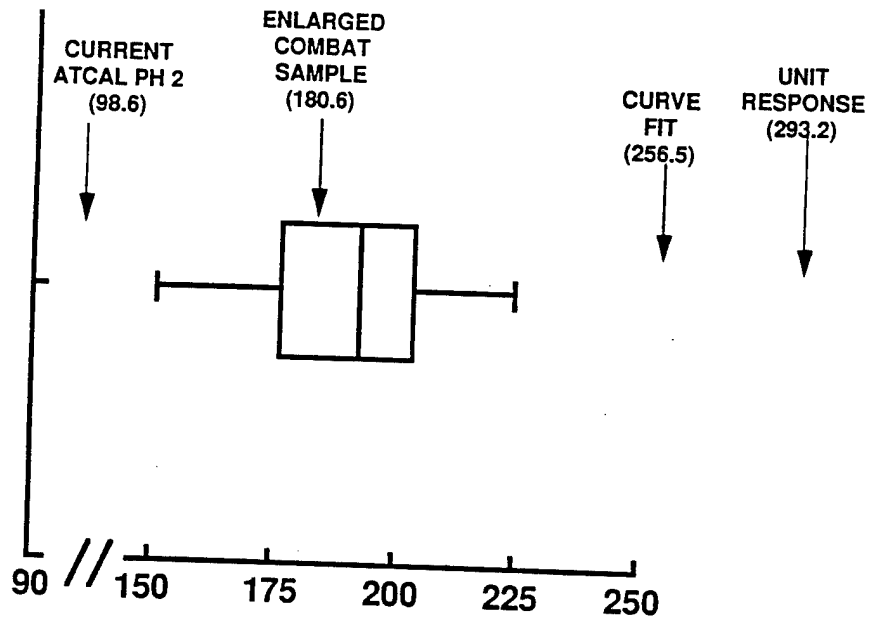

Figure F-19. Total Kills by MLRS - 144 MLRS

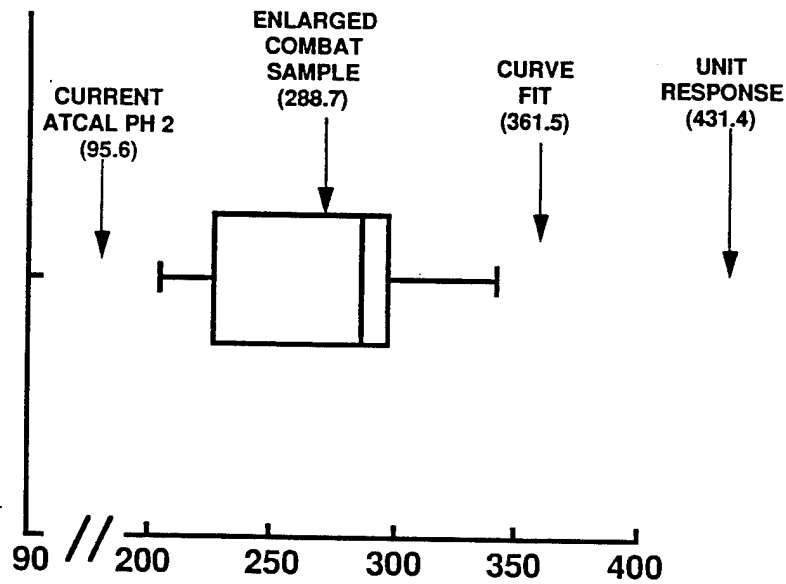

Figure F-20. Total Kills by MLRS - 252 MLRS

APPENDIX G
DISTRIBUTION

Internal Distribution	Number of copies
Reference copy:	
Unclassified Library	2
Record copy:	
CSCA-FET	20

GLOSSARY

1. ABBREVIATIONS, ACRONYMS AND SHORT TERMS

AIMS	Army Integrated Mobilization Study
ammo	ammunition
ATCAL	Attrition Calibration: an attrition model using calibrated parameters
ATVAL PHASE I	ATCAL Evaluation: the evaluation of direct fire in ATCAL
ATVAL PHASE II	ATCAL Evaluation: the evaluation of indirect fire in ATCAL
CAA	US Army Concepts Analysis Agency
CADEM	Calibrated Differential Equation Methodology
CEM	Concepts Evaluation Model: a theater-level model
COSAGE	Combat Sample Generator: a tactical-level model
EEA	essential element(s) of analysis
FEBA	forward edge of the battle area
FER	force exchange ratio: LER/force ratio
FORCEM	Force Evaluation Model
LER	loss exchange ratio: loss of Blue/loss of Red
LN	natural logarithm
M	model
MLRS	multiple launch rocket system
mm	millimeter
MOE	measure of effectiveness
P	processor
PK	probability of kill
QTY	quantity
RALPH	Reduction ATCAL Link, Phase I
RAND	The RAND Corporation

RL	rocket launcher
SER	system exchange ratio: kills by system/kills of system
SR	study report
TAC THUNDER	a two-sided, theater-level model designed to simulate a conventional war, primarily air combat; it does contain a ground combat portion
TAFSM	Target Acquisition Fire Support Model: the Field Artillery School's division-level simulation of opposing artillery forces
TP	technical paper

2. DEFINITIONS

calibrated sample

The posture specific tactical simulation used by ATCAL.

combat sample

The posture specific output developed by the tactical simulation.

extrapolation

The estimation of a value of a variable outside its tabulated or observed range.

force ratio

The fraction of equipment present for battle. Usually calculated as Red divided by Blue.

force size

Number of units per side. This is usually devoted by such names as corps, division, brigade, battalion, etc.

interpolation

To insert, estimate, or find an intermediate term in a sequence of numbers.

tactical simulation

Any simulation at the tactical level used to to drive ATCAL calibration values. During the course of this study, the Combat Sample Generator was used as the simulation of choice.

theater simulation

Any simulation at the theater level, i.e., Europe, Korea, and Southwest Asia.