

NASA
Reference
Publication
1092

May 1982

Standard Tests
for Toughened
Resin Composites

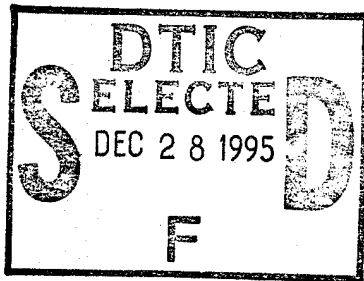

DISTRIBUTION STATEMENT A
Approved for public release
Distribution Unlimited

19951222 038

DTIC QUALITY INSPECTED 1

DEPARTMENT OF DEFENSE
ASTRO TECHNIQUE EVALUATION CENTER
WASHINGTON, D.C. 20330

NASA

PLASTEC 43234

**NASA
Reference
Publication
1092**

1982

Standard Tests for Toughened Resin Composites

*Compiled by
ACEE Composites Project Office
Langley Research Center
Hampton, Virginia*

Accession For	
NTIS CRA&I	<input checked="" type="checkbox"/>
DTIC TAB	<input type="checkbox"/>
Unannounced	<input type="checkbox"/>
Justification	
By	
Distribution /	
Availability Codes	
Dist	Avail and/or Special
A-1	



National Aeronautics
and Space Administration

Scientific and Technical
Information Branch

FOREWORD

Technology leading to the application of advanced composites in secondary and empennage structures for commercial transport aircraft has been under development in the Aircraft Energy Efficiency (ACEE) Program for several years. This program, which is nearing completion, has achieved a high degree of success; the aircraft manufacturers are now in a position to consider composite versions of such structures in plans for future aircraft. Their consideration will be backed by personnel experienced in all areas of design, manufacture, and quality control; by a tested interface with material suppliers, the FAA, and the airlines; and by first-hand experience with the cost and weight benefits of such composite structures.

Although the application of composites to secondary and medium primary components can achieve a fuel savings of up to 3 percent on current transport aircraft, studies indicate that weight savings associated with extensive use of composite structures in wing and fuselage components will lead to a fuel savings of 10 to 15 percent over similar aircraft with conventional structures. Opportunities for technology advancements, which will significantly enhance these benefits, exist in areas such as tougher resin development, thick laminate processibility, durability and damage tolerance, and strength-critical design optimization. In fact, research programs are underway within NASA and the Aircraft Industry to develop resin matrix composites which will exploit the full weight-reduction potential for strength-critical primary aircraft structures. The immediate goal in these programs is to increase the allowable design strain to 6000 $\mu\text{in}/\text{in.}$ while maintaining desirable features in processibility, mechanical properties, and environmental stability.

Concurrent with the new material development, the commercial transport manufacturers are under contract to NASA to develop long-lead-time technology for application of advanced composites to primary aircraft structures. Since several toughened resin systems are being evaluated in these contracts, NASA conducted a workshop in December 1981 to achieve commonality among the manufacturers for certain kinds of tests used to characterize toughened resin composites. Out of this workshop, specifications for five tests were standardized; these test standards are described in this reference publication. For more detailed information on such items as apparatus and procedures, the reader should contact the principal contributor listed in the table on the following page.

STANDARD TESTS FOR TOUGHENED RESIN COMPOSITES

Test designator	Test type	Ply orientation	Nominal thickness	Test specimen size, in.	Principal contributor
ST-1	Compression after impact	[+45/0/-45/90] _{ns}	0.25 in.	7 by 12.5 (before impact) 5 by 12.5 (after impact)	Charles F. Griffin Lockheed-California Company Burbank, California 213-847-3862
ST-2	Edge delamination tension	[±30/±30/90/90] _s [±35/0/90] _s	11 plies 8 plies	1.5 by 10	T. Kevin O'Brien Structures Laboratory AVRADCOM Research and Technology Laboratories NASA Langley Research Center Hampton, Virginia 804-827-3011
ST-3	Open-hole tension	[+45/0/-45/90] _{ns}	0.25 in.	2 by 12	D. J. Watts Douglas Aircraft Company Long Beach, California 213-593-3442
ST-4	Open-hole compression	[+45/0/-45/90] _{ns}	0.25 in.	5 by 12.5	Charles F. Griffin Lockheed-California Company Burbank, California 213-847-3862
ST-5	Double cantilever beam	[0] _n	0.065 ± 0.007 in.	0.5 by 8	William G. Roeseler Boeing Commercial Airplane Company Seattle, Washington 206-655-3129

ST-1: SPECIFICATION FOR COMPRESSION AFTER IMPACT TEST

INTRODUCTION

The ST-1 specification defines the test specimens, test apparatus, test procedures, and data to be compiled for compression tests on graphite/epoxy laminates after impact.

DESCRIPTION OF TEST LAMINATE

The graphite/epoxy test laminate shall have a nominal thickness of 0.25 in. and an orientation of $(+45/0/-45/90)_{NS}$. The specimen shall be cured with a 0.25-in.-diameter disc made of Du Pont Teflon or equivalent imbedded in one corner of the panel for an NDI (nondestructive inspection) standard and shall be ultrasonically inspected to determine laminate quality and to provide a basis of comparison for postimpact ultrasonic inspection. Record laminate thickness and resin content. Place an identification number on one side of the laminate. Do not paint the laminate.

TEST SPECIMEN DIMENSIONS

The impact test specimen (fig. 1) shall have a width of 7.00 in. The length shall be not less than 10.0 in. nor greater than 12.5 in. After impact the specimens shall be trimmed to a width of 5 ± 0.03 in. for compression test to failure.

TEST APPARATUS

Impact Test

The impact test apparatus (fig. 2) shall consist of a base plate, a top plate, and an impactor. The impactor shall weigh 10.0 lb, be less than 10 in. in length, and have a 0.5-in. hemispherical steel tip on the end that impacts the specimen. A guide tube lined with Du Pont Teflon or equivalent for the impactor is also required.

Compression Test

The compression test apparatus (fig. 3) shall provide simple support to the compression test specimen along its long edges oriented parallel to the compression loading direction. The short edges (loaded edge) shall be clamped between the two adjustable steel plates of the upper and lower sections of the apparatus to provide resistance to end brooming.

TEST PROCEDURE

Impact Test

The graphite/epoxy test specimen shall be placed in the impact test assembly (fig. 2) with the identification side up so that the desired impact location is centered within the 5.0- by 5.0-in. central opening in the base plate. The top plate shall then be placed upon the test specimen and clamped to the base plate by instal-

ling nuts on the four tie-down studs and torquing each one to a nominal 20 ft-lb. Alignment pins are provided in the base plate so that the top plate is correctly positioned. The guide tube shall be located above the test specimen so that the impactor will strike the center of the specimen. The lower end of the guide tube shall be approximately 10 in. above the surface of the specimen. Coat the striker end of the impactor with white chalk dust or white grease to allow easy location of the actual impact point. Drop the impact from a height of 2 ft above the test specimen to generate an impact energy of 20 ft-lb. Care should be taken to deflect the impactor away from the specimen after the strike so that a restrike does not occur. Remove the impacted specimen from the test apparatus and visually (naked eye) determine the amount of damage to the specimen on the impacted surface (side with the specimen identification) and the back surface. The specimen shall then be ultrasonically inspected to determine the extent of internal delamination.

Compression Test

The compression test specimen shall be loaded to failure by using a stroke-controlled testing machine. A loading rate of 0.05 in/min is recommended. The load-strain behavior of the test specimen shall be recorded throughout the test by using all four strain gages. The specimen shall be installed in the compression test apparatus (fig. 3) such that (1) the specimen is parallel to the load axis of the machine and is centered in the machine; (2) the side supports on the edges parallel to the loading axis shall be a snug fit, but not tight, so that the specimen can still slide in the vertical direction; and (3) a 0.050-in. clearance is provided between each side of the specimen and the side supports to prevent any transverse load due to Poisson deformation being restrained.

NUMBER OF TESTS

Three impact tests shall be conducted at an impact energy of 20 ft-lb. These three specimens shall be tested to failure in compression.

TEST DATA REPORTING

For each impact test, record (1) identification number; (2) thickness; (3) resin content; (4) orientation; (5) impact energy; (6) front surface and back surface visual damage measurements; (7) ultrasonic indication measurements using C-scan and, where possible, associated B-scan records; (8) total delamination area from the ultrasonic measurements; and (9) compression failure load.

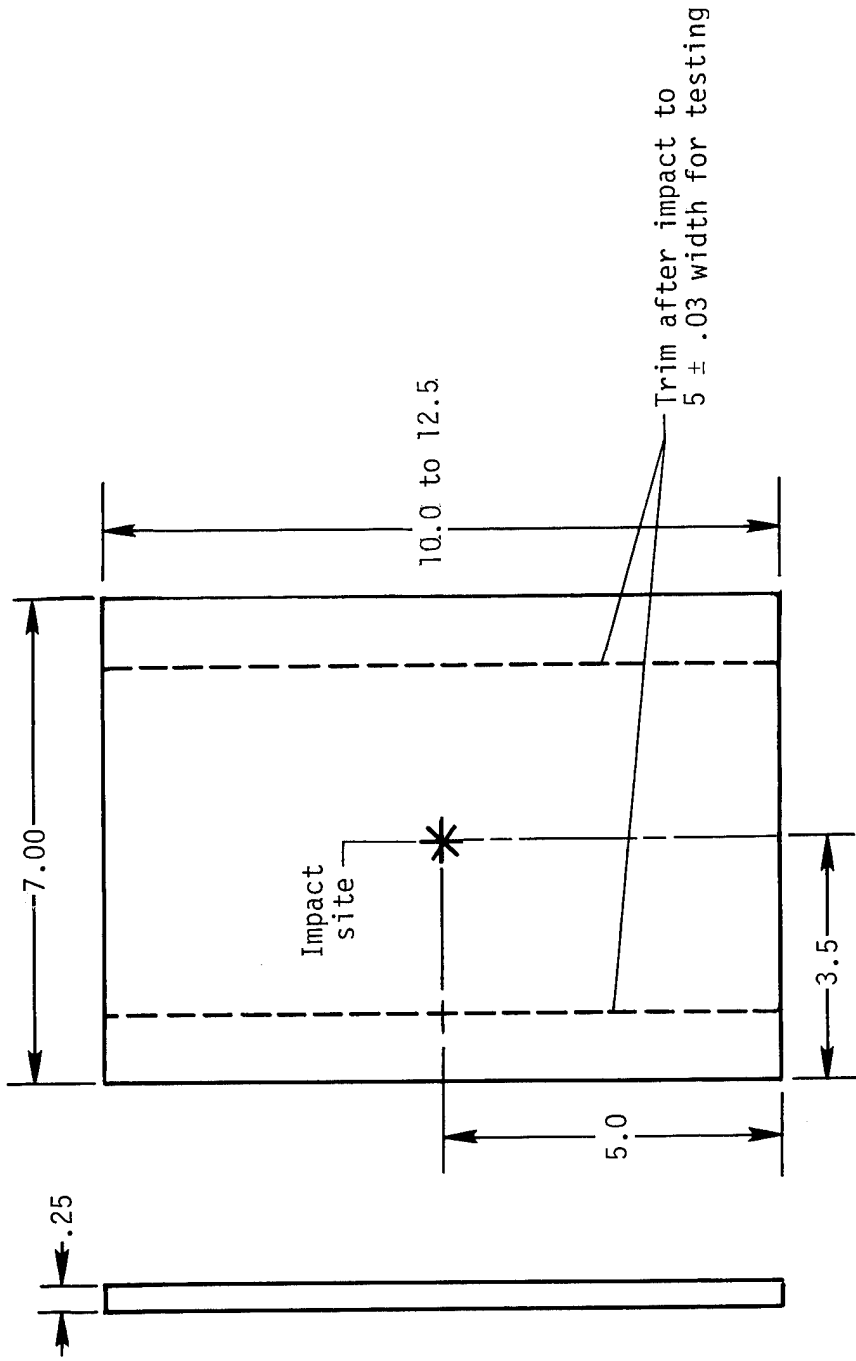

Figure 1.- Compression after impact test specimen. Dimensions are in inches.

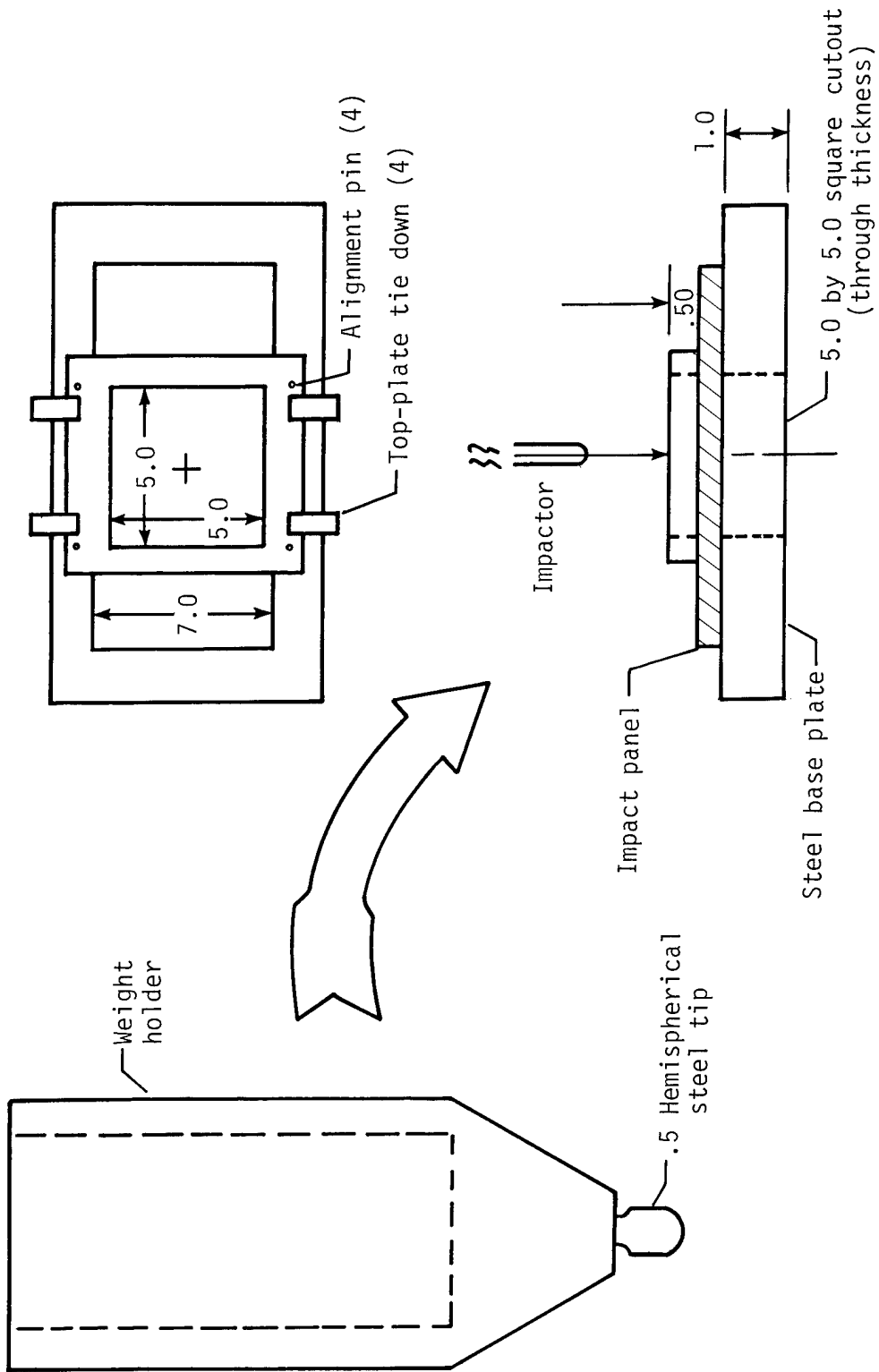

Figure 2.- Impact test apparatus. Dimensions are in inches.

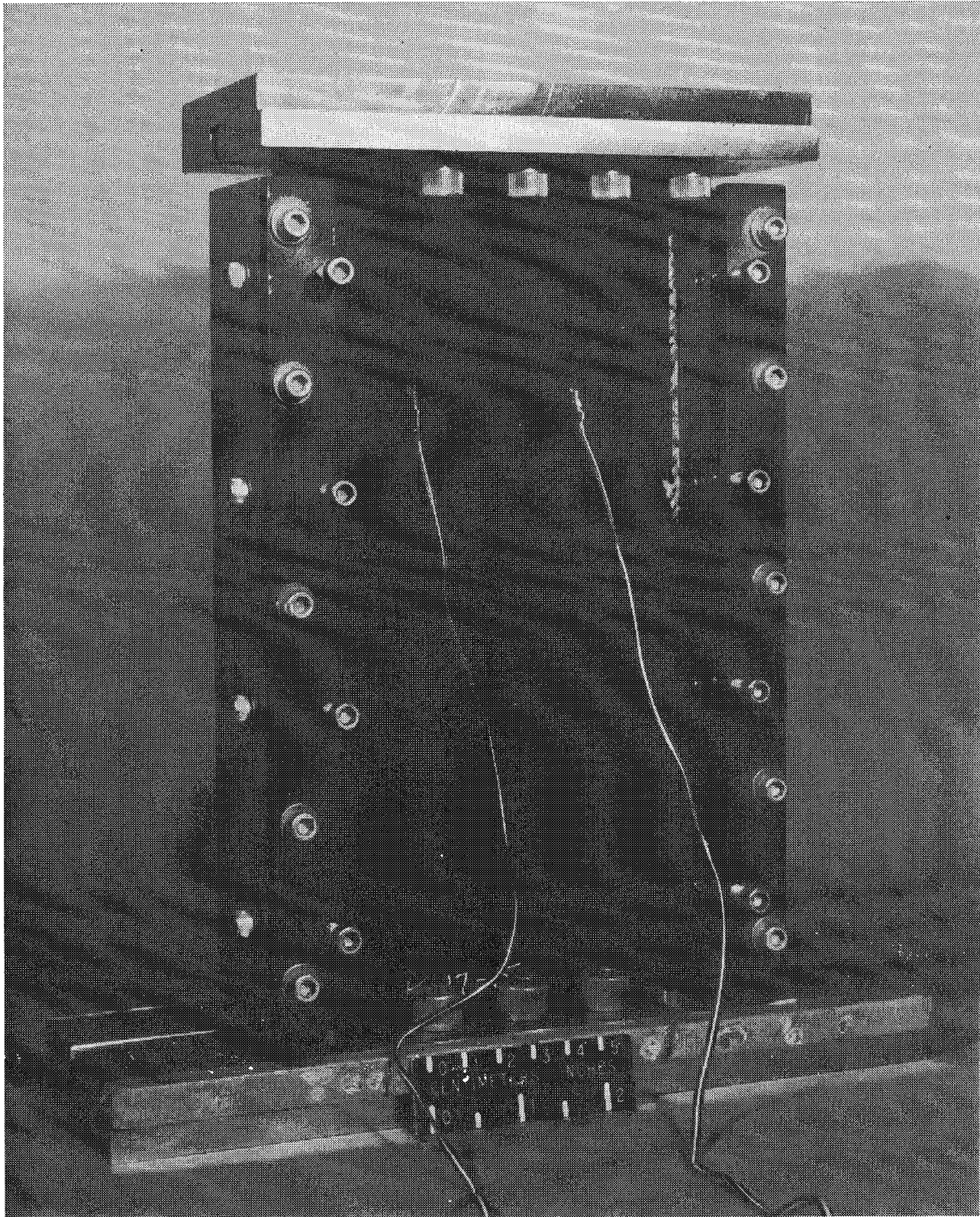

Figure 3.- Compression test apparatus.

L-82-128

ST-2: SPECIFICATION FOR EDGE DELAMINATION TENSION TEST

INTRODUCTION

The ST-2 specification defines the test specimens, test apparatus, test procedures, and data to be compiled for the edge delamination tension test on graphite/epoxy laminates.

DESCRIPTION OF TEST LAMINATE

Make two panels for the chosen toughened-resin composite. One panel shall consist of an 11-ply lay-up (+30/-30/+30/-30/90/90/90/-30/+30/-30/+30)_T, and the other panel shall consist of an 8-ply lay-up (+35/-35/0/90/90/0/-35/+35)_T. Perform quality assurance C-scans on both panels and report results. Record manufacture date, batch and roll numbers, prepreg tape thickness, and basic information from vendor on fiber and resin properties. Determine and record resin content of panels after cure.

TEST SPECIMEN DIMENSIONS

Each test specimen shall be 10 in. long and 1.5 in. wide. Other details of the specimen are shown in figure 4.

TEST APPARATUS

Specimens shall be mounted in a properly aligned load frame. Use either a stroke-controlled, screw-driven machine or a stroke-controlled (or strain-controlled) hydraulic machine. (Note: "Stroke controlled" controls crosshead displacement, whereas "strain controlled" controls displacement over the gage length of the strain-measuring device mounted on the specimen.) Do not run tests in load control. Maintain 7 in. between grips (fig. 4). Emery cloth or tungsten carbide grit inserts should be sufficient at the grips. However, if end tabs are used, they should be squared off, not tapered (fig. 5). To measure nominal strain, use one of the two setups shown in figure 6. Mount on the specimen either (1) a pair of LVDT's (linear variable differential transducers) or DCDT's (direct-current differential transducers), one on either side, or (2) an extensometer (clip gage) with an appropriate extender arm. The gage length shall be 4 in. with gage mounts 1.5 in. from either grip (fig. 4).

TEST PROCEDURE

Five specimens of each laminate shall be tested. Prior to test, measure the laminate thickness, using micrometers, at the three locations along each edge as shown in figure 4 and record the average thickness. (If the variation in thickness measurements is greater than 3 mils, record each measurement.) Measure the specimen width at the three locations along the specimen length and record the average width. Load specimens at a slow rate (approximately 0.002 mm/sec). Record output of LVDT's (average of front and back) or extensometer on X-axis, and record load on Y-axis of an x-y plotter (real-time analog display). Continue loading until visible detection of edge delamination and corresponding abrupt (not continuous) deviation in load-deflection plot occurs (fig. 7). Record strain level at the onset of delamina-

tion ϵ_c . Note this point on the load-deflection curve. If thickness variations greater than 3 mils are found, record thickness at location closest to delamination site. Measure initial laminate modulus E_0 from linear portion of load deflection curve. (See fig. 7.) For the laminate shown, the load-deflection plot is linear up to the onset of delamination. However, if gradual nonlinearity precedes the onset of delamination, measure a secant modulus E_{sec} from the origin to the delamination onset point in the load-deflection plot. This should be of concern for the 11-ply lay-up $(\pm 30/\pm 30/90/90)_s$ only and not for the 8-ply lay-up $(\pm 35/0/90)_s$. For two of the five $(\pm 35/0/90)_s$ specimens, continue the loading until the specimen fractures into two pieces. Record the strain at failure ϵ_f which should be close to the vendor's reported fiber ultimate tensile strain. For all other specimens, stop loading at the onset of delamination.

TEST DATA REPORTING

For specimens tested, record (1) laminate thickness t ; (2) laminate modulus E_0 , and E_{sec} if necessary; (3) delamination onset strain ϵ_c ; and (4) strain at failure ϵ_f for two of the $(\pm 35/0/90)_s$ specimens. Also record moduli E_{11} and E_{22} , Poisson's ratio ν_{12} , and shear modulus G_{12} for the toughened-resin composite. Mention how these properties were measured, that is, E_{11} and ν_{12} from a $(0)_s$ tension test and G_{12} from $(\pm 45)_s$ tension test.

METHOD OF TOUGHNESS CALCULATION

Calculate $(\pm 30/\pm 30/90/90)_s$ and $(\pm 35/0/90)_s$ laminate stiffness E_{lam} from lamina properties. Compare to average measured laminate modulus E_0 . Calculate $(\pm 30)_s$ and $(\pm 35/0)_s$ laminate stiffness from lamina properties; then calculate E^* for the 11-ply lay-up

$$E^* = \frac{8E_{(\pm 30)_s} + 3E_{(90)}}{11}$$

and for the 8-ply lay-up

$$E^* = \frac{6E_{(\pm 35/0)_s} + 2E_{(90)}}{8}$$

Calculate interlaminar fracture toughness G_c for each test and then average

$$G_c = \frac{\epsilon_c^2 t}{2} (E_{lam} - E^*)$$

where t is the average laminate thickness or the thickness measured closest to the delamination location if thickness variations are greater than 3 mils.

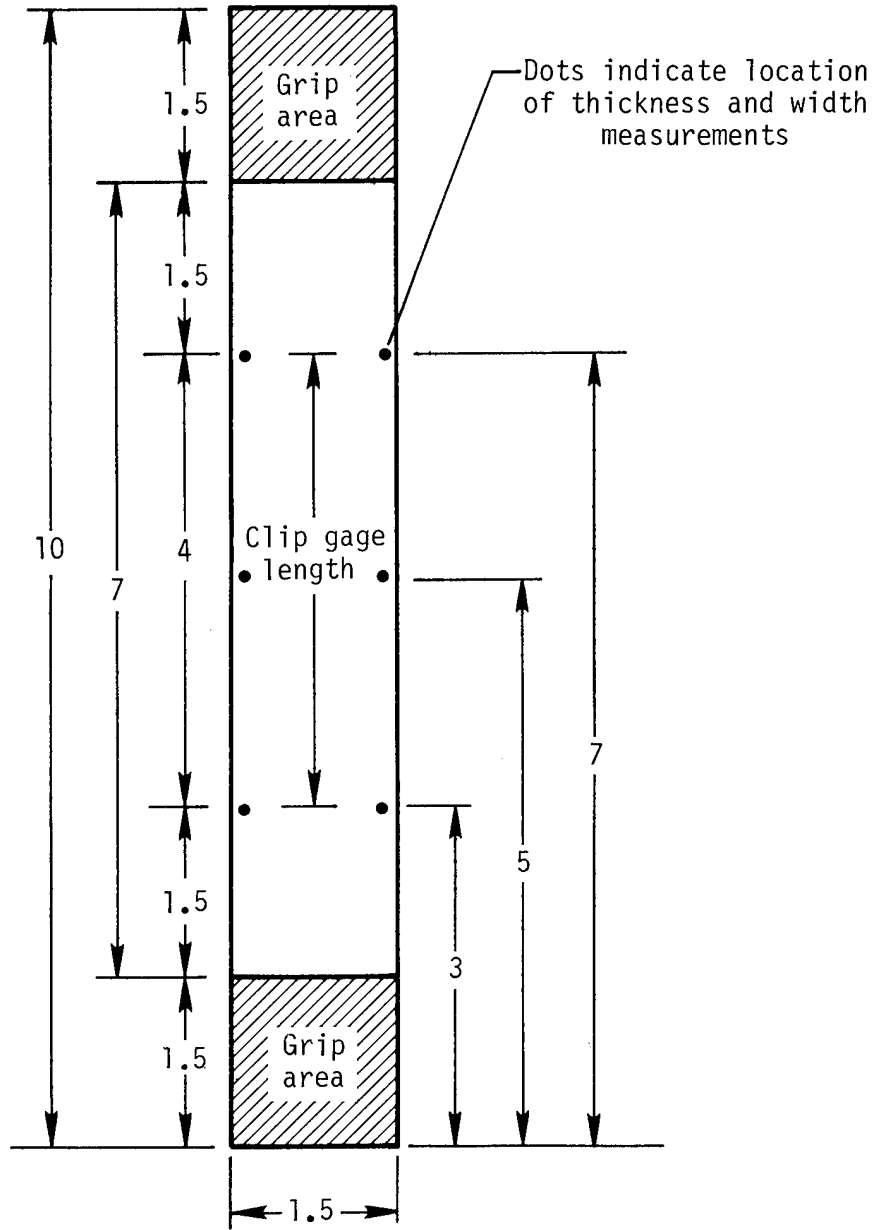

Figure 4.- Edge delamination tension test specimen.
 Dimensions are in inches.

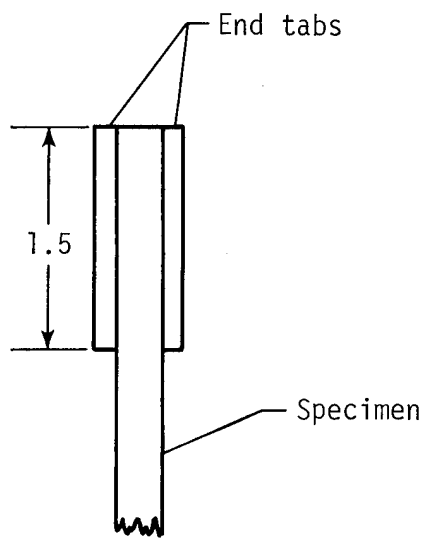
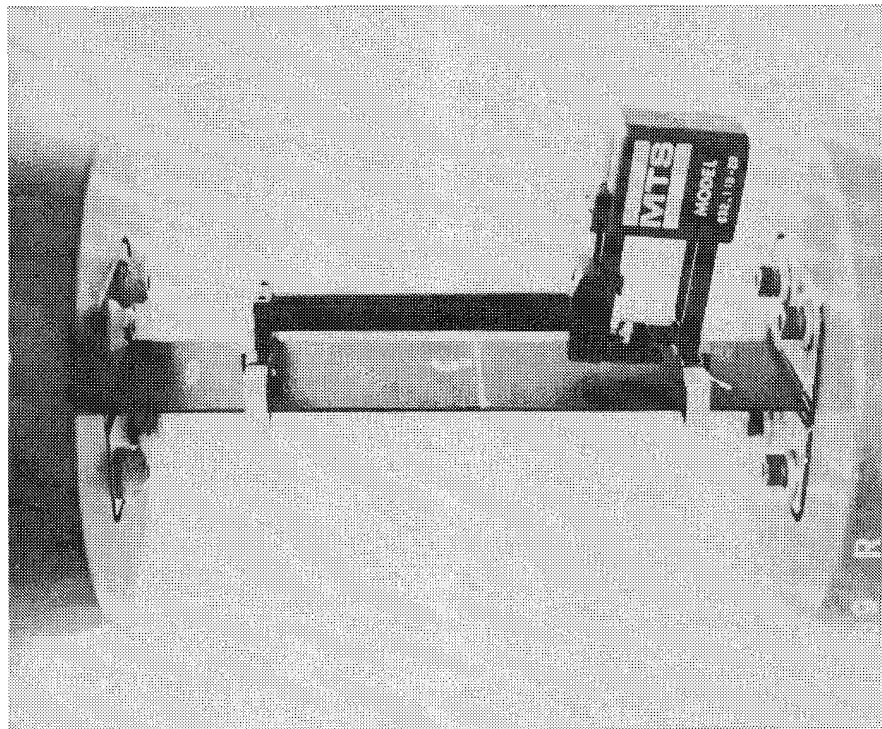

Figure 5.- Edge view of end tab configuration. Dimension is in inches.

Extensometer (clip gage) with
extender arm



L-82-129

LVDT's (DCDT's)

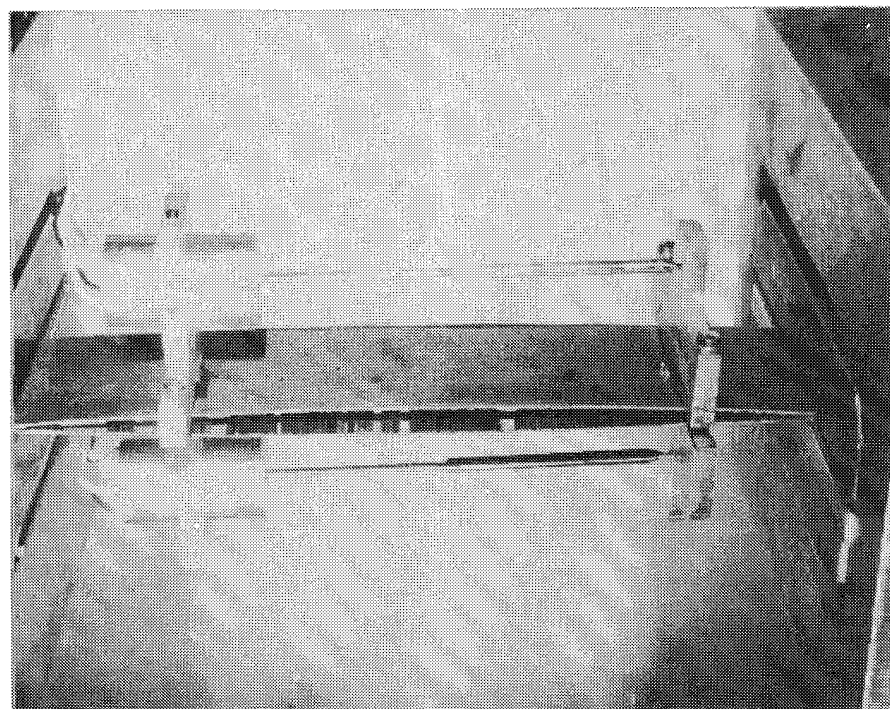

Figure 6.- Typical instrumented test specimens.

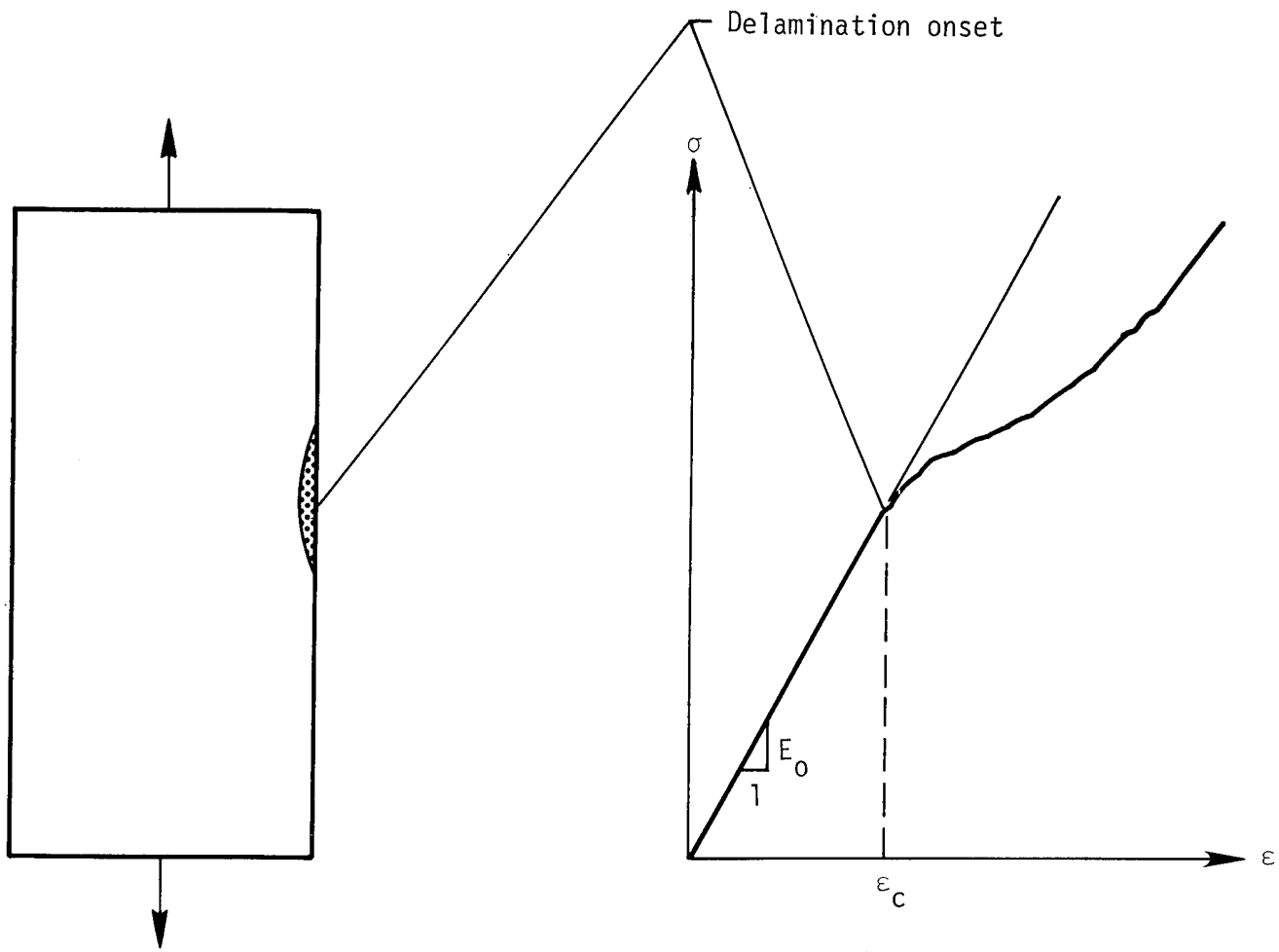

Figure 7.- Critical G_C determination.

ST-3: SPECIFICATION FOR OPEN-HOLE TENSION TEST

INTRODUCTION

The ST-3 specification defines the test specimens, test apparatus, test procedures, and data to be compiled for the ultimate tension strength testing of graphite/epoxy materials containing an open hole.

DESCRIPTION OF TEST LAMINATE

The graphite/epoxy test laminate shall have a nominal thickness of 0.25 in. and an orientation of (+45/0/-45/90)_{ns}. After the laminate has been manufactured, it shall be ultrasonically inspected to determine laminate quality. Record the laminate thickness and resin content. Place an identification number on one side of the laminate. Do not paint the laminate.

TEST SPECIMEN DIMENSIONS

The tension test specimen shall have a width of 2.00 in. The minimum length of the specimen shall be 12.00 in. with a minimum of 8 in. between grips. The hole diameter shall be 0.25 in. and shall be located as shown in figure 8. Each test specimen shall have one axial strain gage mounted at the location shown in figure 8. Each specimen shall have an identification number marked on it.

TEST LOADS

The test specimen shall be loaded to failure at a loading rate of approximately 20 000 lb/min. The failure strength of the specimen in figure 8 shall be in the range of 15 000 to 25 000 lb.

TEST APPARATUS

Any certified tensile testing machine with a load capability $\geq 25\ 000$ lb shall be adequate. Also any loading fixture (such as hydraulic and "bookend") designed to properly align the specimen and preclude eccentric loading shall be acceptable.

NUMBER OF TESTS

Three tension tests shall be conducted to failure.

TEST DATA REPORTING

For each tension test, record (1) identification number, (2) thickness, (3) width, (4) resin content of the laminate from which the specimen was cut, (5) measured hole diameter, (6) failure location, (7) failure load, and (8) failure strain.

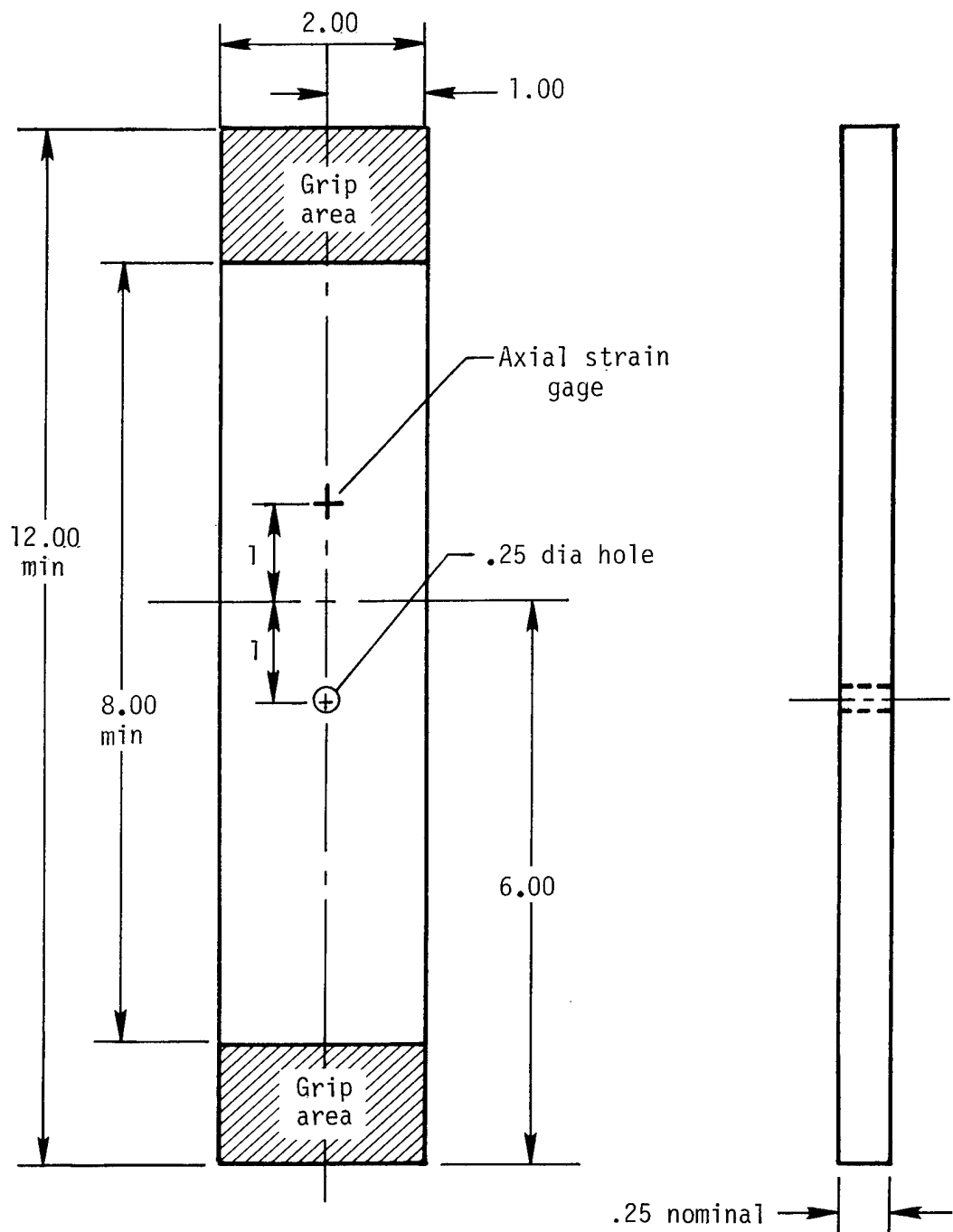

Figure 8.- Open-hole tension test specimen. Dimensions are in inches.

ST-4: SPECIFICATION FOR INPLANE OPEN-HOLE COMPRESSION TEST

INTRODUCTION

The ST-4 specification defines the test specimens, test apparatus, test procedures, and data to be compiled for inplane compression tests on graphite/epoxy laminates containing an open hole.

DESCRIPTION OF TEST LAMINATE

The graphite/epoxy test laminate shall have a nominal thickness of 0.25 in. and an orientation of $(+45/0/-45/90)_{ns}$. After the laminate has been manufactured it shall be ultrasonically inspected to determine laminate quality. Record laminate thickness and resin content. Place an identification number on one side of the laminate. Do not paint the laminate.

TEST SPECIMEN DIMENSIONS

The compression test specimen (fig. 9) shall have a width of 5.00 ± 0.03 in. The length of the specimen shall be 10.0 in. minimum to 12.5 in. maximum. The hole diameter shall be 1.0 in. and shall be located at the center of the specimen. Each specimen shall have a minimum of four axial strain gages mounted back to back at the locations shown in figure 9. Each specimen shall have an identification number marked on it.

TEST APPARATUS

The compression test apparatus (fig. 10) shall provide simple support to the compression test specimen along its long edges oriented parallel to the compression loading direction. The short edges (loaded edge) shall be clamped between the two adjustable steel plates of the upper and lower sections of the apparatus to provide resistance to end brooming.

TEST PROCEDURE

The compression test specimen shall be loaded to failure by using a stroke-controlled testing machine. A loading rate of 0.05 in/min is recommended. The load-strain behavior of the test specimen shall be recorded throughout the test by using all four strain gages. The specimen shall be installed in the compression test apparatus (fig. 10) such that (1) the specimen is parallel to the load axis of the machine and is centered in the machine; (2) the side supports on the edges parallel to the loading axis shall be a snug fit, but not tight, so that the specimen can still slide in the vertical direction; and (3) a 0.050-in. clearance is provided between each side of the specimen and the side supports to prevent any transverse load due to Poisson deformation being restrained.

NUMBER OF TESTS

Three compression test specimens which contain a 1.0-in.-diameter open hole shall be tested.

TEST DATA REPORTING

For each compression test, record (1) identification number, (2) thickness, (3) width, (4) resin content of the laminate from which the specimen was cut, (5) measured hole diameter, (6) failure location, (7) failure load, and (8) load-strain data.

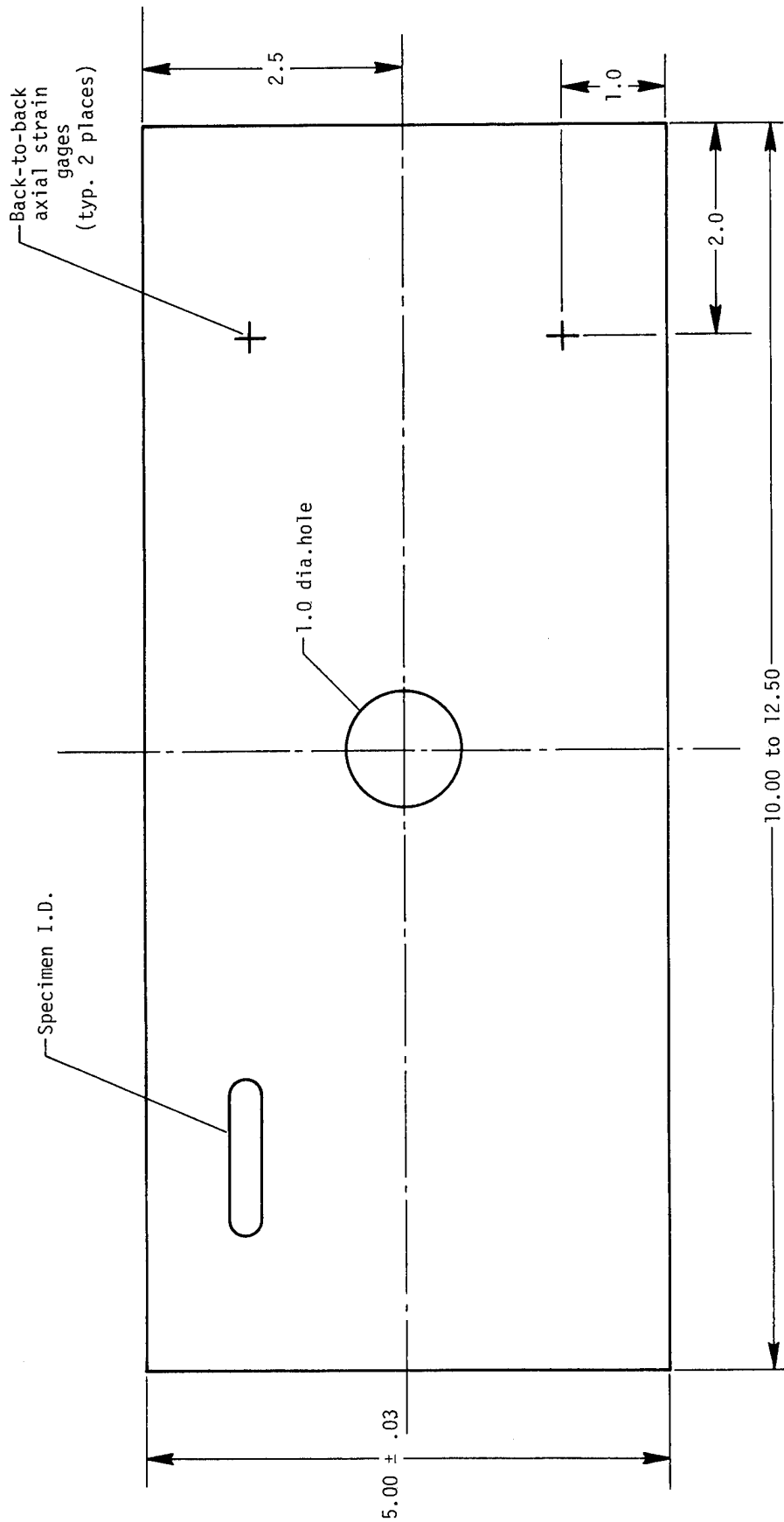

Figure 9.- Inplane open-hole compression test specimen. Dimensions are in inches.

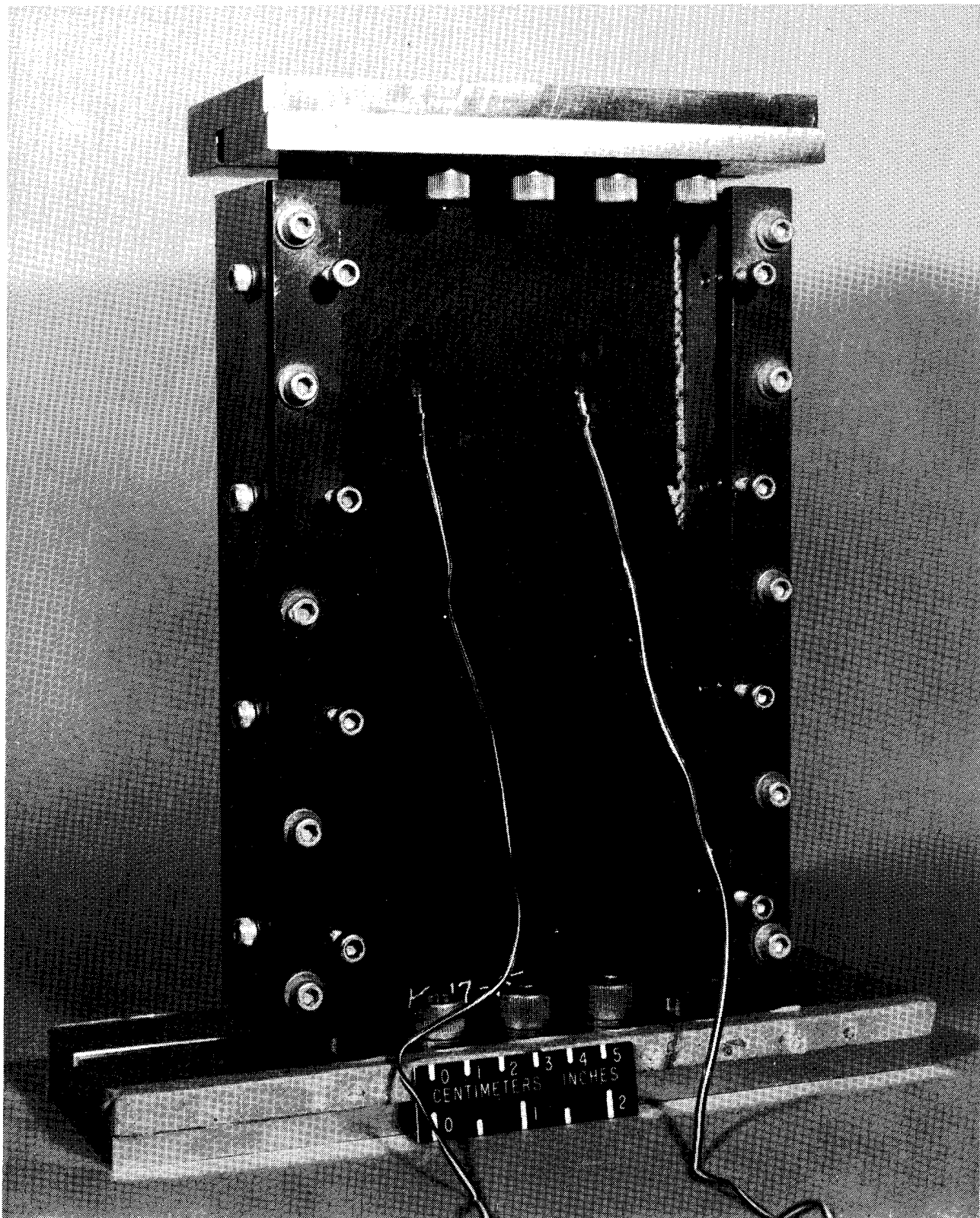

Figure 10.- Compression test apparatus.

L-82-128

ST-5: SPECIFICATION FOR DOUBLE CANTILEVER BEAM TEST

INTRODUCTION

The ST-5 specification defines the test specimens, test apparatus, test procedures, and data to be compiled for the double cantilever beam (DCB) test.

DESCRIPTION OF TEST LAMINATE

The graphite/epoxy test laminate shall have an even number of plies and a cured thickness of 0.065 ± 0.007 in. and an orientation of $0^\circ \pm 2^\circ$ with a 2-mil crack starter (Du Pont Teflon or Du Pont Kapton film or equivalent) in the center. (See fig. 11.) Record laminate thickness and resin content.

FABRICATION OF TEST SPECIMEN

Fabricate the adherends according to figure 11 in order to give an overall specimen width of 0.5 in. and a length of 8 in. Anodize the adherends with phosphoric acid or etch according to the Forest Products Laboratory (FPL) method and prime with American Cyanamid BR-127 or equivalent prior to bonding. Bond the laminates to the adherends with 3M EC 2216B/A or an equivalent room-temperature adhesive. Use Monsanto Cerex style 3603-23 positioning fabric (scrim cloth) or equivalent. Use positioning devices and apply pressure (up to atmospheric) during cure so that parallelity, alignment, and bond line thickness are maintained. Measure and record the total depth of the test specimen at the crack initiation point and at a point 2 in. toward the bonded end. These measurements shall include the adherends, adhesive, and laminate.

TEST APPARATUS

Any certified tensile testing machine with a load capability ≥ 300 lb shall be adequate. Also any loading fixture designed to properly align the specimen and preclude eccentric loading shall be acceptable. The DCB test specimens shall be supported in the test machine at the free end to prevent shear loads on the crack tip.

TEST PROCEDURE

The DCB test specimen shall be loaded at a constant rate until the crack starts to grow at which time loading of the specimen is stopped and the crack allowed to "coast" until crack arrest is observed. Then the load is applied until the crack starts to grow again. This procedure shall be repeated until the DCB test specimen is pulled to two-part failure. During the entire procedure a plot of load against deflection shall be made as shown in figure 12. Also the sides of the DCB specimens shall be painted white with marks at 1-mm increments and long marks at 1 cm to aid in crack tip measurements. Crack tip position shall be measured to the nearest millimeter either photographically or by other suitable means after each crack extension. Measurements shall be made on both sides of the coupon and recorded separately.

NUMBER OF TESTS

Three DCB tests shall be conducted.

DATA ACQUISITION

Load, deflection, and crack tip extension shall be measured as shown in figure 12 and described in the test procedure and recorded.

STRAIN-ENERGY RELEASE RATE CALCULATION

The strain-energy release rate shall be calculated by the following method. Average the right and left crack lengths for all crack arrest points in the first 2 in. of crack growth. If there are more than three such points, use only the three most distinct points, the points preceded by the maximum extensions. If the first crack extension exceeds 2 in., use only the first crack arrest point and record only the raw data. Calculate the critical strain-energy release rate for each arrest point by the following equation:

$$G_{Ic} = \frac{\partial(\text{Energy})}{\partial(\text{Area})}$$

where

$$\text{Energy} = \frac{P\delta}{2}$$

$$\text{Area} = ba$$

$$P = \text{Load}$$

$$\delta = \text{Head travel} \approx \text{Crack opening displacement}$$

$$b = \text{Width} \approx 0.5 \text{ in.}$$

$$a = \text{Crack length}$$

Beam theory gives

$$\delta = \frac{2Pa^3}{3EI} + \frac{3Pa}{Gb}$$

where

$$E = \text{Young's modulus}$$

$$G = \text{Shear modulus} \approx 4M \text{ lb/in}^2$$

I = Moment of inertia

h = One-half total depth of beam

An example calculation of critical strain energy G_{IC} follows. The equivalent modulus may be obtained by using the measured total beam depth (as shown in the sketch) and the following approximate moduli E :

10.5M lb/in² for aluminum

0.5M lb/in² for adhesive

19.0M lb/in² for graphite

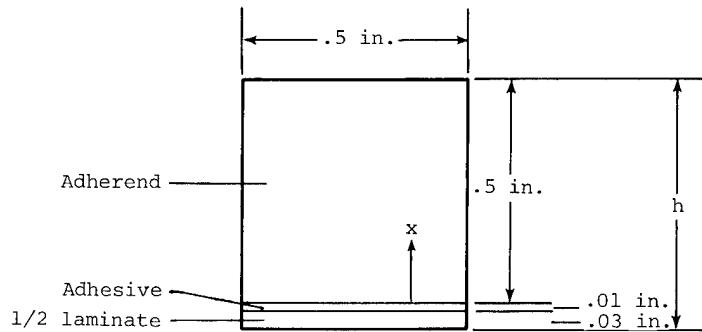

	E	A	x	EA	EAx	EAx^2	EI_o
Adherend	10.5M	0.250	0.250	2.625M	0.656M	0.164M	0.055M
Adhesive	0.5M	.005	-.005	.002M	.000M	.000M	.000M
Laminate	19.0M	$\frac{.015}{0.270}$	-.025	$\frac{.285M}{2.912M}$	$\frac{-.007M}{0.649M}$	$\frac{.000M}{0.164M}$	$\frac{.000M}{0.055M}$

(A is area and I_o is moment of inertia through the center of each element (adherend, adhesive, and 1/2 laminate).)

$$EI = \sum EI_o + \sum EAx^2 - (\bar{x})^2 \sum EA$$

$$\bar{x} = \frac{\sum EAx}{\sum EA} = 0.223$$

$$EI = 0.055M + 0.164M - (0.223)^2 2.912M$$

$$EI = 0.074M$$

$$\begin{aligned} E_{\text{equivalent}} &= \frac{EI \times 12}{bh^3} \\ &= \frac{0.074M \times 12}{0.5(0.54)^3} \\ &= 11.3M \text{ lb/in}^2 \end{aligned}$$

Thus,

$$\text{Energy} = \frac{P\delta}{2} = \frac{P^2 a^3}{3EI} + \frac{3P^2 a}{2Gb^2 h}$$

Although P , a , and δ are all variable during the test, the standard procedure is to use the partial derivative of energy with respect to area as an approximation to the strain-energy release rate as follows:

$$G_{Ic} = \frac{\partial(\text{Energy})}{\partial(\text{Area})} = \frac{\partial(\text{Energy})}{b \partial a}$$

$$G_{Ic} = \frac{P^2 a^2}{EIb} + \frac{3P^2}{2Gb^2 h}$$

Substituting typical values as given previously, gives

$$G_{Ic} = \frac{P^2 a^2}{0.074(10^6)(0.5)} + \frac{3P^2}{2(4)(10^6)(0.5)^2(0.54)}$$

$$G_{Ic} = \frac{P^2 a^2}{3.7 \times 10^4} + \frac{P^2}{3.6 \times 10^5}$$

Substituting typical test points from the typical raw data in figure 12, $a = 2$ in. and $P = 100$ lb, gives

$$G_{Ic} = \frac{(100)^2(2)^2}{3.7 \times 10^4} + \frac{(100)^2}{3.6 \times 10^5}$$

$$G_{Ic} = 1.08 + 0.03$$

$$G_{Ic} = 1.11 \text{ lb/in.}$$

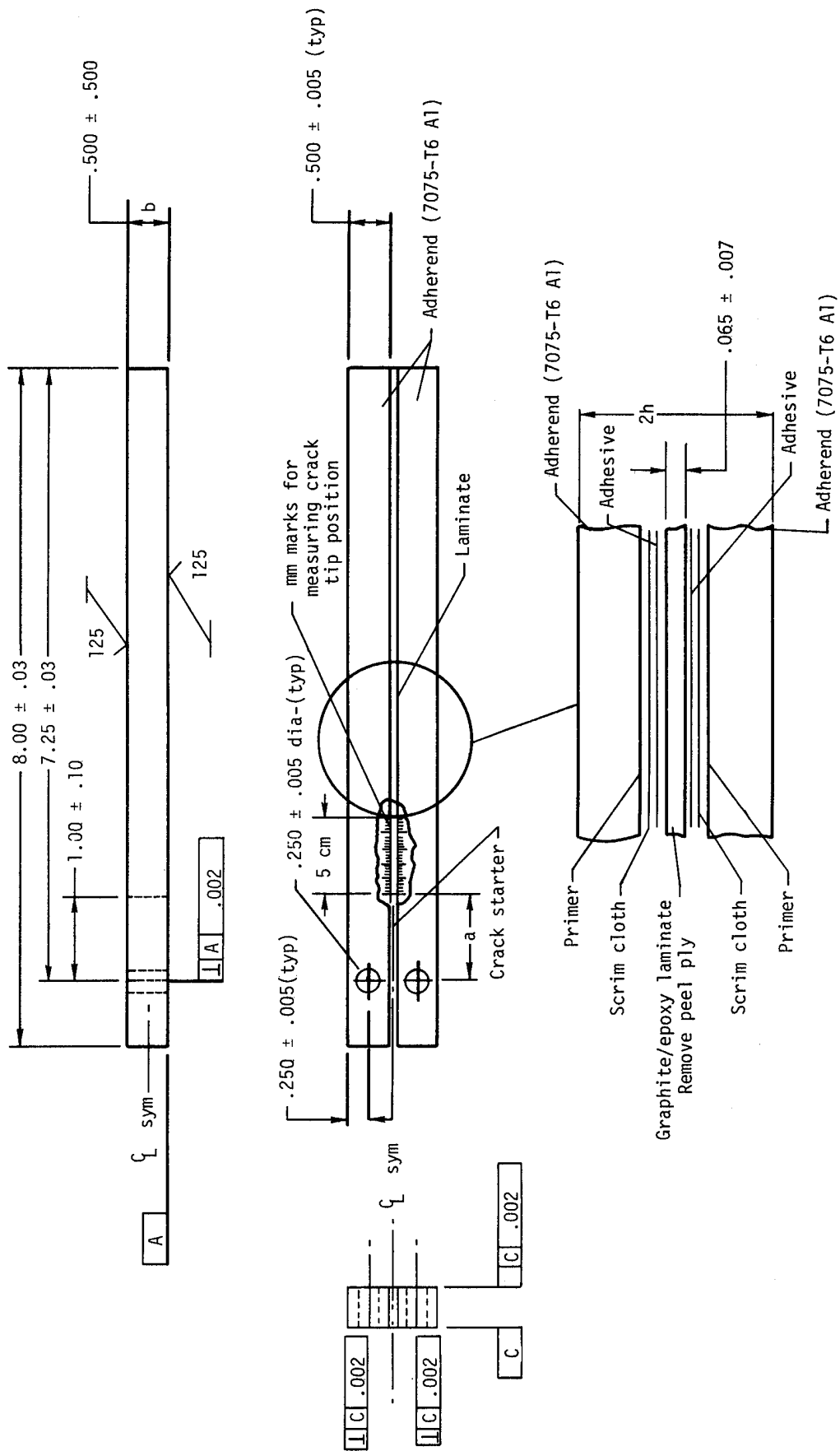

Figure 11.- Double cantilevered beam test specimen. Dimensions are in inches.

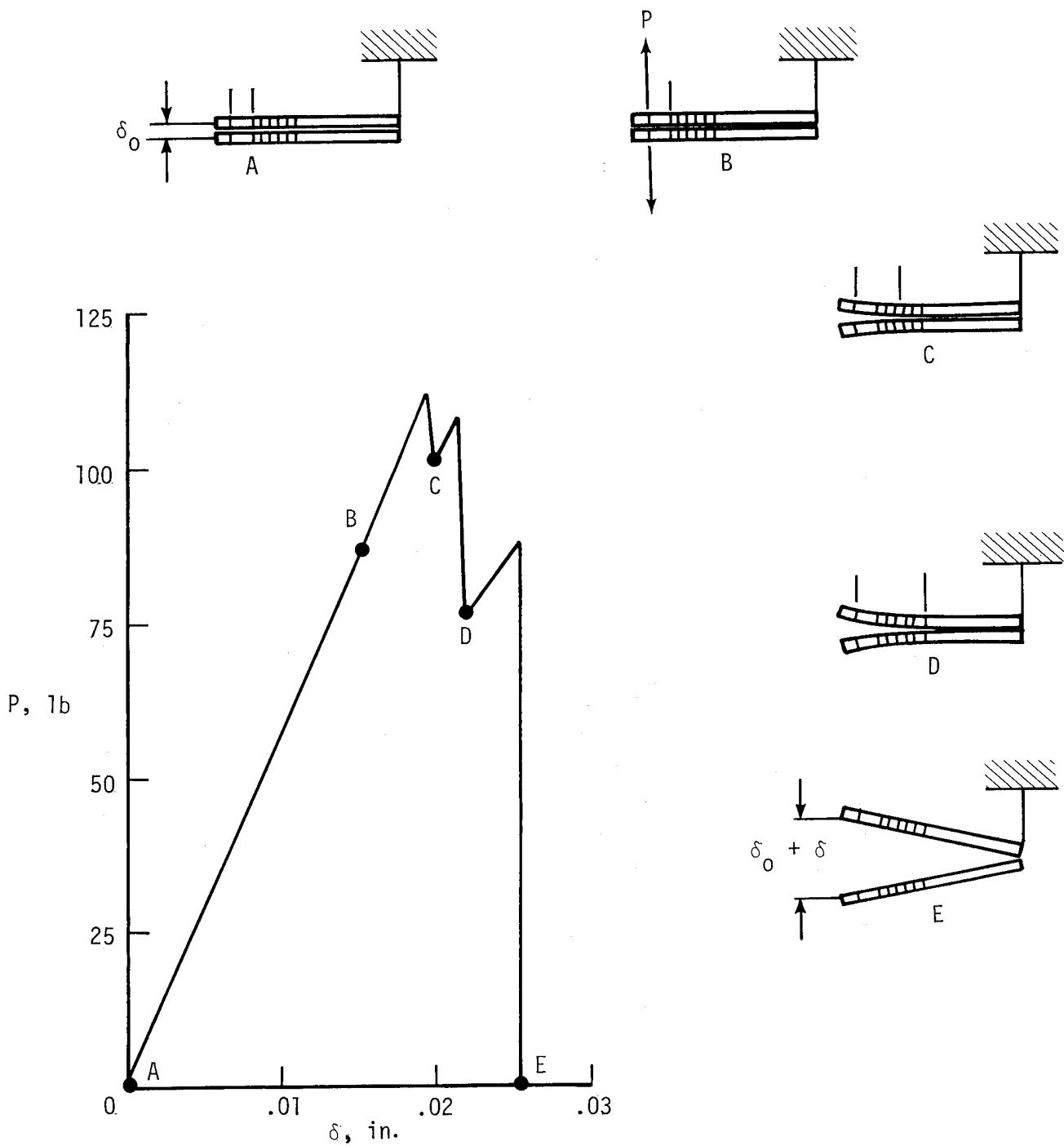

Figure 12.- Typical raw data. Dimensions are in inches.

1. Report No. NASA RP-1092	2. Government Accession No.	3. Recipient's Catalog No.	
4. Title and Subtitle STANDARD TESTS FOR TOUGHENED RESIN COMPOSITES		5. Report Date May 1982	6. Performing Organization Code 534-03-13-01
		8. Performing Organization Report No. L-15317	10. Work Unit No.
7. Author(s) Compiled by ACEE Composites Project Office	9. Performing Organization Name and Address NASA Langley Research Center Hampton, VA 23665		11. Contract or Grant No.
12. Sponsoring Agency Name and Address National Aeronautics and Space Administration Washington, DC 20546			13. Type of Report and Period Covered Reference Publication
		14. Sponsoring Agency Code	
15. Supplementary Notes			
16. Abstract The commercial transport manufacturers are under contract with NASA to develop long-lead-time technology for application of advanced composites to primary aircraft structures. Since several toughened resin systems are being evaluated in these contracts, NASA conducted a workshop in December 1981 to achieve commonality among the manufacturers for certain kinds of tests used to characterize toughened resin composites. Out of this workshop, specifications for five tests were standardized; these test standards are described in this reference publication.			
17. Key Words (Suggested by Author(s)) Composites Graphite/epoxy Test specifications		18. Distribution Statement Unclassified - Unlimited Subject Category 24	
19. Security Classif. (of this report) Unclassified	20. Security Classif. (of this page) Unclassified	21. No. of Pages 27	22. Price A03