

EFFECTS OF LONG-TERM EXPOSURE TO FUELS AND FLUIDS
ON BEHAVIOR OF ADVANCED COMPOSITE MATERIALS

E. Y. Tanimoto



Langley Research Center
Hampton, Virginia

August 1981

19951226 013

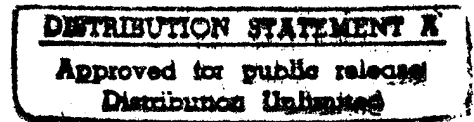

DEPARTMENT OF DEFENSE
PLASTICS TECHNICAL EVALUATION CENTER
BROADCOM DRIVE
WRIGHT-PATTERSON AIR FORCE BASE
DAYTON, OHIO 45433-6151

U.S. DEPARTMENT OF COMMERCE
National Technical Information Service



PLASTED
430832

NASA Contractor Report 165763

(NASA-CR-165763) A STUDY OF THE EFFECTS OF
LONG-TERM EXPOSURE TO FUELS AND FLUIDS ON
THE BEHAVIOR OF ADVANCED COMPOSITE MATERIALS
Final Report (Boeing Commercial Airplane
Co., Seattle) 40 p HC A03/MF A01 CSCL 11D G3/24

N82-18327

Unclas
09139

Effects of Long-Term Exposure to Fuels and Fluids on Behavior of Advanced Composite Materials

E. Y. Tanimoto

Boeing Commercial Airplane Company
P. O. Box 3707
Seattle, Washington 98124

CONTRACT NAS1-12428
AUGUST 1981

REPRODUCED BY
NATIONAL TECHNICAL
INFORMATION SERVICE
U.S. DEPARTMENT OF COMMERCE
SPRINGFIELD, VA. 22161

NASA

National Aeronautics and
Space Administration

Langley Research Center
Hampton, Virginia 23665

Accession For	
NTIS CRA&I	<input checked="" type="checkbox"/>
DTIC TAB	<input type="checkbox"/>
Unannounced	<input type="checkbox"/>
Justification	
By	
Distribution /	
Availability Codes	
Dist	Avail and/or Special
A-1	

1. Report No CR-165763		2. Government Accession No.		3. Recipient's Catalog No.	
4. Title and Subtitle A STUDY OF THE EFFECTS OF LONG-TERM EXPOSURE TO FUELS AND FLUIDS ON THE BEHAVIOR OF ADVANCED COMPOSITE MATERIALS				5. Report Date August 1981	
				6. Performing Organization Code	
7. Author(s) E. Y. Tanimoto				8. Performing Organization Report No D6-41185-9	
9. Performing Organization Name and Address Boeing Commercial Airplane Company P. O. Box 3707 Seattle, Washington 98124				10. Work Unit No.	
				11. Contract or Grant No. NAS1-12428	
				13. Type of Report and Period Covered Contractor Report	
12. Sponsoring Agency Name and Address National Aeronautics and Space Administration Washington, DC 20546				14. Sponsoring Agency Code	
15. Supplementary Notes NASA Technical Representative: Mr. H. Benson Dexter Final Report					
16. Abstract This program involved the periodic testing and evaluation of graphite/epoxy and Kevlar/epoxy material systems after subjecting test specimens to prolonged exposure to several laboratory-controlled environments deemed typical of normal aircraft operations. This investigation showed that specimen immersion in water or water-based fluids resulted in the greatest effect on the mechanical properties tested. Also, the environmental fluids showed a tendency to affect Kevlar/epoxy systems at an earlier exposure period than the graphite/epoxy systems. Results also indicate mechanical property strength retention generally being lower for the Kevlar/epoxy systems when compared to the corresponding graphite/epoxy systems in similar environments, after prolonged exposure.					
17. Key Words (Suggested by Author(s)) Graphite-epoxy Kevlar-epoxy Environmental exposure				18. Distribution Statement Unclassified-unlimited Star Category 24	
19. Security Classif. (of this report) Unclassified		20. Security Classif. (of this page) Unclassified		21. No. of Pages 37	22. Price*

NASA CONTRACTOR REPORT 165763

EFFECTS OF LONG-TERM EXPOSURE TO FUELS AND FLUIDS
ON BEHAVIOR OF ADVANCED COMPOSITE MATERIALS

E. Y. Tanimoto

August 1981

Prepared under Contract NAS1-12428 by

Boeing Commercial Airplane Company

P.O. Box 3707

Seattle, Washington 98124

for

Langley Research Center

NATIONAL AERONAUTICS AND SPACE ADMINISTRATION

FOREWORD

This report documents the work performed by The Boeing Company for the National Aeronautics and Space Administration, Langley Research Center (NASA-LaRC), under Contract NAS1-12428. The objective of the program was to investigate and evaluate the effects of long-term exposure to aircraft fluids on the behavior of advanced composite materials. The program called for periodic monitoring and testing of specimens, both stressed (25% of ultimate) and unstressed, exposed to the following laboratory-controlled environments: (1) JP-4 fuel, (2) Skydrol hydraulic fluid, (3) fuel-water mixture, (4) wet (fuel)-dry (air) cycling, (5) ambient air (control), and (6) water immersion.

The work was performed in two separate tasks. Task 1 began in June 1974 and Task 2 in December 1975, each running for a period of 5 years. Tasks 1 and 2 were successfully completed, and the final results and conclusions of both tasks are included in this report.

Task 1 involved exposure and periodic testing of tensile and short beam shear specimens fabricated with T300 tape/5209 and Kevlar 49 Fabric/2544. Task 2 involved exposure and periodic testing of tension and short beam shear specimens fabricated with T300 tape/5208, Kevlar 49 fabric/5209 and Kevlar 49 bare fibers.

This program was administered by the Langley Research Center, National Aeronautics and Space Administration, with Mr. H. Benson Dexter of the Materials Division as the technical monitor. Mr. E. Y. Tanimoto of the Boeing Commercial Airplane Company was the program leader.

Use of commercial products or names of manufacturers in this report does not constitute official endorsement of such products or manufacturers, either expressed or implied, by the National Aeronautics and Space Administration.

CONTENTS

	Page
1.0 INTRODUCTION AND BACKGROUND	1
2.0 TECHNICAL APPROACH	3
2.1 General Discussion	3
2.2 Materials	5
2.3 Environmental Exposure Conditions	9
3.0 RESULTS AND DISCUSSION	15
3.1 Prepreg and Laminate Physical Properties	15
3.2 Exposure Test Results	15
3.3 Discussion	28
4.0 CONCLUSIONS	33
REFERENCES	35

1.0 INTRODUCTION AND BACKGROUND

There is a continuing effort to increase the structural efficiency and improve the fatigue life of commercial aircraft. The use of low-density, high-modulus, high-strength filamentary composites to save weight is a direct approach to achieving better structural efficiency; the use of structural adhesives instead of mechanical fasteners is a direct approach to improving fatigue life. The introduction of these new materials and concepts requires not only extensive development programs, but also service testing of complete components to determine their behavior under service loads and environments.

For several years, Boeing has conducted development programs to adapt advanced composite materials technology to production airplane components. For example, NASA Contract NAS1-11668, "A Study of the Effects of Long Term Ground and Flight Environmental Exposure on the Behavior of Graphite-Epoxy Spoilers," has provided for the fabrication, installation, and flight test of 111 graphite/epoxy spoilers on Boeing Model 737 commercial airplanes. Some of these spoilers have been in service for 8 years; the program will monitor the service performance of the spoilers for a total of 10 years.

While the graphite/epoxy spoiler program provides an exceptional opportunity to gain worldwide climatic exposure data under actual fleet operating conditions, the effects of other environments, such as prolonged exposure to hydraulic oils or fuels, also warrant systematic study. Portions of airplane structure are exposed to a variety of these fluids during normal operation. Successful incorporation of advanced composite materials in aircraft structure, particularly in primary structure requires materials that are inert to normal aircraft fluids. This is especially true when these materials are considered for uses such as in the integral fuel tank structure. Therefore, the capability of composite materials to withstand this environment must be determined by testing these materials after long-term exposure. The results of five years exposure of composite materials to six different environments are reported herein.

2.0 TECHNICAL APPROACH

2.1 GENERAL DISCUSSION

For several years, Boeing has conducted research and development programs on advanced composite materials in structural applications. These programs have progressed to the point where two graphite/epoxy flight spoilers are being test flown on a Model 737 aircraft and two boron/epoxy foreflaps are being flown on a Model 707 aircraft. Both components have been FAA approved and are being flown on airplanes in commercial service. Additional flight-test data will be accumulated by monitoring the flight-service experience of 111 graphite/epoxy spoilers under NASA Contract NAS1-11668. NASA instituted the Aircraft Energy Efficiency Programs to improve the fuel efficiency of commercial aircraft. Under this program, contracts were let to various aerospace companies to develop and verify new technology. Boeing received contract NAS1-15025 to fabricate, certify and install composite stabilizers on 737 aircraft. The certification analysis and documentation are currently being prepared for the Federal Aviation Administration. Boeing also received contract NAS 1-14952 to fabricate certify and install composite elevators on 727 aircraft. Currently, five United Airlines aircraft are in service with composite elevators. Boeing was recently awarded a contract to study the durability and damage tolerance of large composite primary aircraft structure. This program will fabricate and test a composite wing structure. It is significant that these programs offer the opportunity for extensive service evaluation under actual fleet operating conditions, because continued development of advanced composite materials will necessitate the assurance that the materials are inert to fluids typical of normal aircraft operation.

This program involved the testing and evaluation of four advanced composite materials subjected to prolonged exposure to several laboratory-controlled environments deemed typical of normal aircraft operations. These environments included specimen immersion in JP-4 fuel; Skydrol hydraulic fluid; fuel-water mixture; fuel-air cycling; ambient air exposure; and water immersion. The program called for engineering surveillance and evaluation during exposure. Post-exposure inspection, test, and progress reporting were done throughout the program.

The flow chart shown in Figure 1 describes the overall layout of the program.

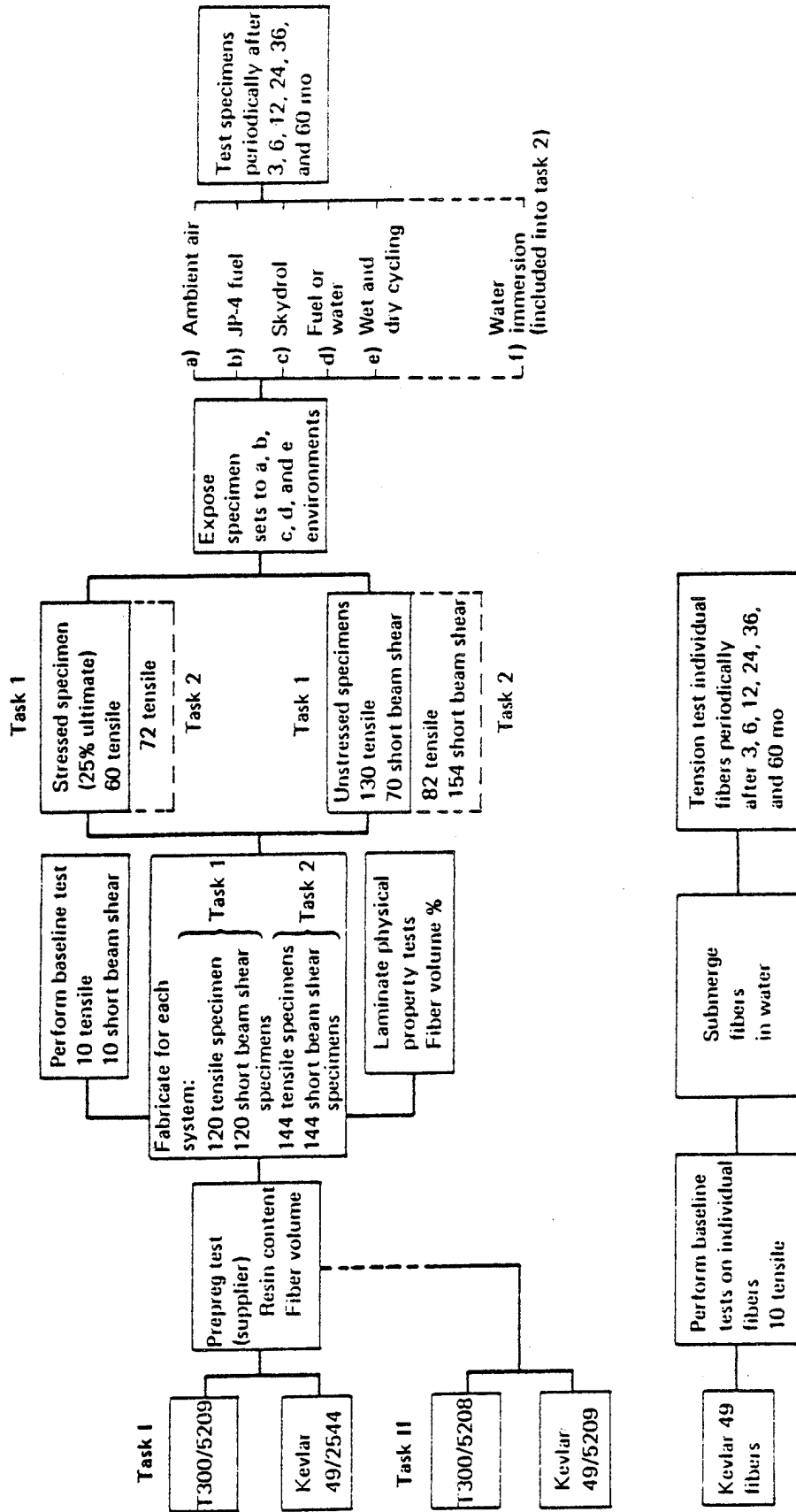

Figure 1. Program Flow Chart

2.2 MATERIALS

Several commercially available epoxy matrices and graphite fiber reinforcements were considered as candidates for this study. The systems selected are listed in Table 1.

The selection criteria included:

- o Commonality of material with that selected for spoilers under Contract NAS1-11668
- o Quality and reproducibility
- o Fabricability
- o Availability

Specifically, System I used a material common to one of the graphite/epoxy materials selected for the spoilers fabricated and tested under Contract NAS1-11668. The material was of proven manufacturing quality and reproducibility, the fabrication procedure was well defined, and the material was available commercially. System IV used the same matrix resin as System I, but incorporated a completely different fiber. This provided a minimum of processing development, since the different fiber will have little influence on the composite's cure schedule and fabrication characteristics. System II used a resin common to another material used for the spoilers under Contract NAS1-11668, but incorporated a completely different fiber. Again, the choice was dictated by the lack of processing development required and the well-known fabrication characteristics of the matrix resin. System III used the same fibers as System I, but with a higher temperature curing epoxy resin system.

The selection of matrix resins common to those used for the spoiler program precluded process variables from significantly impacting the fabrication of composite specimens suitable for exposure studies. The materials selected also offered an opportunity to compare results with those obtained on the spoilers. Paired exposure of Thornel 300 graphite fiber with Kevlar 49 was made possible by selection of the same resin for Systems I and IV. Paired exposure of epoxy resin matrices of varying cure characteristics was possible with Systems I and III and with Systems II and IV, since the influence of the fibers in each paired group was expected to be minimal.

The same cure cycle was selected for the test specimen fabrication as was used for the spoiler fabrication under Contract NAS1-11668, due to its proven manufacturing characteristics and known composite quality (Fig. 2).

Table 1. Composite Material Systems Selected for Program

	Fiber	Matrix Resin	Cure Temperature K (°F)	Supplier
System I	Union Carbide Thornel 300	Epoxy 5209	394 (250)	Narmco
System II	DuPont Kevlar 49	Epoxy 2544	450 (350)	Union Carbide
System III	Union Carbide Thornel 300	Epoxy 5208	450 (350)	Narmco
System IV	DuPont Kevlar 49	Epoxy 5209	394 (250)	Narmco

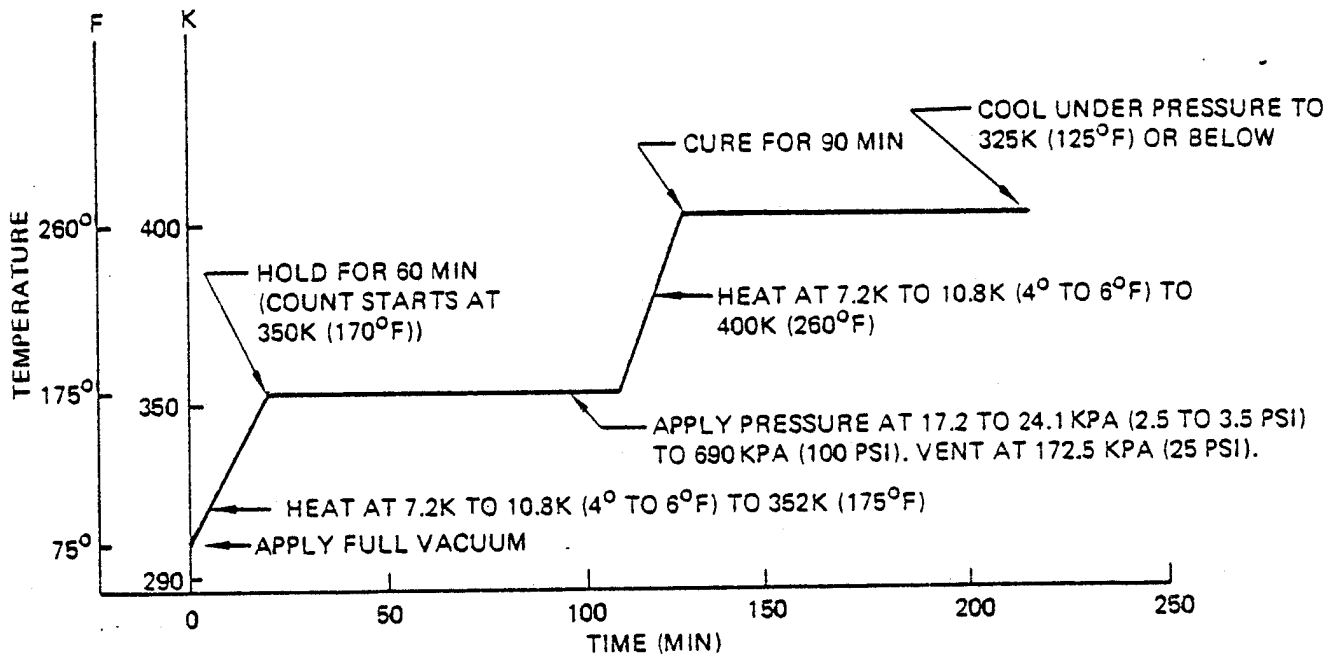

394K (250°F) Cure Cycle.

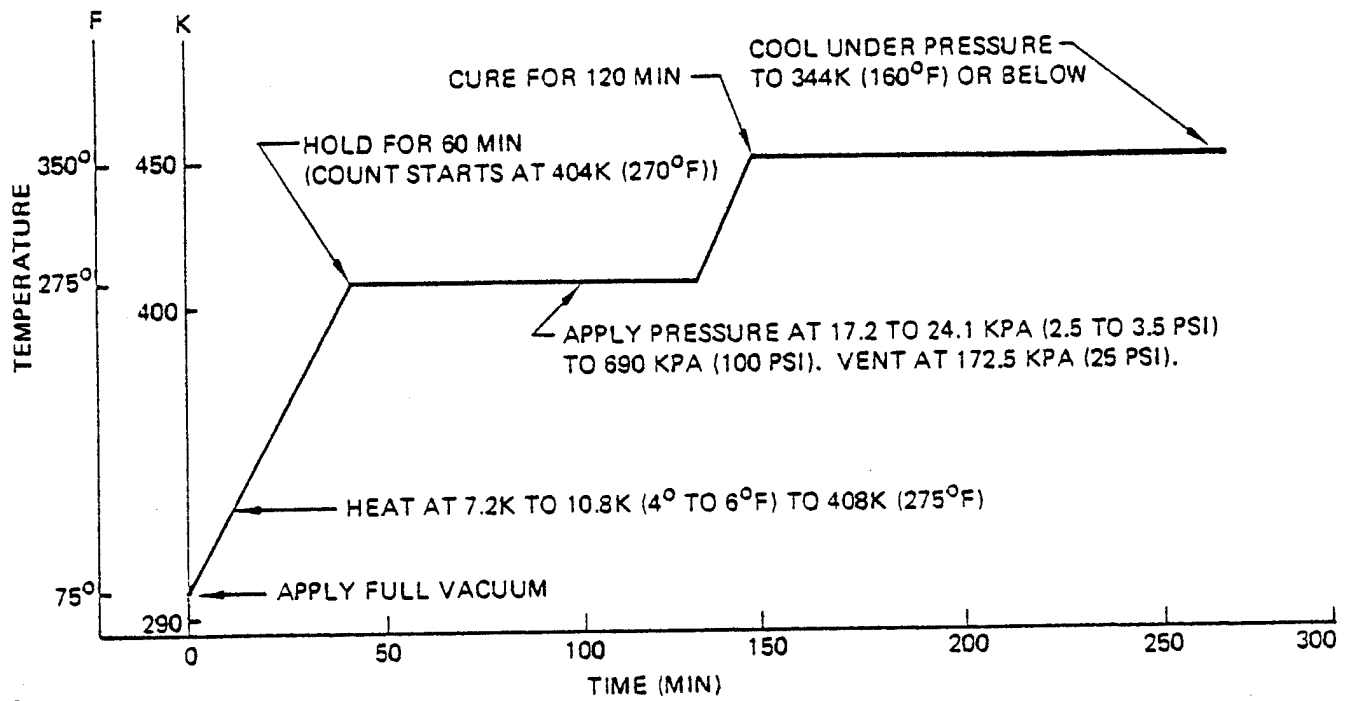

450K (350°F) Cure Cycle

Figure 2. Processing Condition

Composite properties such as interlaminar shear, flexure, and compression strength, to which the matrix makes a significant contribution, are probably the most common properties tested to assess environmental degradation. In particular, the interlaminar short beam shear strength and in-plane shear strength are influenced by the properties of the resin and resin-fiber adhesion and are, therefore, useful properties with which to assess environmental resistance. Taking this into consideration, the short beam shear specimen and the ± 45 -degree tensile specimen were selected for this program.

After NASA concurrence on material selection, the materials were ordered to specifications developed for the spoiler program, except that the Kevlar-49 prepreg was in the form of broadgoods. The following activities were performed:

- o Prepreg property determination
 - o Visual—uniformity and defects
- o Physical property determination
 - o Resin content (percent)
 - o Volatile content (percent)
- o Process confirmation

- o Laminate physical and mechanical property determinations
 - o Fiber volume of shear specimens
 - o Fiber volume of tensile specimens
- o Fabrication of specimens for exposure
 - o Tensile
 - o Shear

The same composite test specimen configurations were used in this investigation as were utilized in the spoiler study. Eight-ply balanced ± 45 degree specimens were employed for tensile testing. Sixteen ply 0-degree specimens were fabricated for the short beam shear tests. An attempt was made to manufacture specimens whose fiber volume fraction was 60 ± 2 percent. The mechanical tests were used to measure the effects of various environments on the mechanical properties of the composite materials. During the environmental exposure, the tensile test specimens were subjected to no load or stressed to 25 percent of their ultimate load. The short beam shear specimens were not stressed during the environmental exposure.

2.3 ENVIRONMENTAL EXPOSURE CONDITIONS

Environmental exposure test conditions imposed on laminate test specimens for each system were as follows:

1. JP-4 immersion
2. Hydraulic fluid immersion
3. Fuel-water immersion
4. Wet (fuel)-dry (air) cycling
5. Ambient air
6. Water immersion (Systems III and IV only)

Environment 1 consisted of specimen immersion in JP-4 fuel, with approximately monthly replacement with fresh fuel. Environment 2 consisted of specimen immersion in Skydrol 500B (Monsanto Company) hydraulic fluid, with approximately monthly replacement of hydraulic fluid. Environment 3 consisted of specimen immersion in a fuel-water mixture, with the fuel-water interface maintained at the center of the test specimens. Bacteria common to fuel tank environments were placed in the test tank. Environment 4 consisted of 24 hours fuel immersion followed by 24 hours air exposure. Environment 5, ambient air, was included in the program as the test control. Environment 6 consisted of specimen immersion in water, with approximately monthly replacement of water. Only Systems III and IV were subjected to Environment 6.

Exposure consisted of subjecting groups of four tensile specimens (two stressed and two unstressed) and four short beam shear specimens from each material system to the environments described above for periods of 3, 6, 12, 24, 36, and 60 months. The specimens were stored in an outdoor shed. Table 2 summarizes the distribution of test specimens for each material system. The configurations of the tensile and short beam shear specimens are shown in Figure 3. The fixtures for the stressed tensile specimens are shown in Figures 4 and 5. The stress level was maintained at 25% of ultimate tensile load. Similar fixtures have been used for sustained-load studies of adhesive bonds during Boeing IR&D studies.

To understand the degradative effect of water on Kevlar 49 fibers, periodic tensile testing was conducted on individual water-immersed Kevlar 49 fibers. Fibers picked at random from Type 968 (1420 Denier, 1000 Filament, and 0 Twist) Kevlar yarn were tested before immersion and after 3, 6, 12, 24, 36 and 60 months of immersion.

Table 2. Distribution of Environmental Test Specimens For Each System

Environment	Tension, number specimens			Shear, number specimens
	Unstressed		Stressed	Unstressed
	Composite	Kevlar 49 fibers	Composite	Composite
None, initial test	10	10		10
JP-4 immersion				
3 mo	2		2	4
6 mo	2		2	4
12 mo	2		2	4
24 mo	2		2	4
36 mo	2		2	4
60 mo	2		2	4
Skydrol immersion				
3 mo	2		2	4
6 mo	2		2	4
12 mo	2		2	4
24 mo	2		2	4
36 mo	2		2	4
60 mo	2		2	4
Fuel or water immersion				
3 mo	2		2	4
6 mo	2		2	4
12 mo	2		2	4
24 mo	2		2	4
36 mo	2		2	4
60 mo	2		2	4
Wet (fuel) and dry (air) cycling				
3 mo	2		2	4
6 mo	2		2	4
12 mo	2		2	4
24 mo	2		2	4
36 mo	2		2	4
60 mo	2		2	4
Ambient air				
3 mo	2		2	4
6 mo	2		2	4
12 mo	2		2	4
24 mo	2		2	4
36 mo	2		2	4
60 mo	2		2	4
Water immersion (task 2 only)				
3 mo	2	10	2	4
6 mo	2	10	2	4
12 mo	2	10	2	4
24 mo	2	10	2	4
36 mo	2	10	2	4
60 mo	2	10	2	4

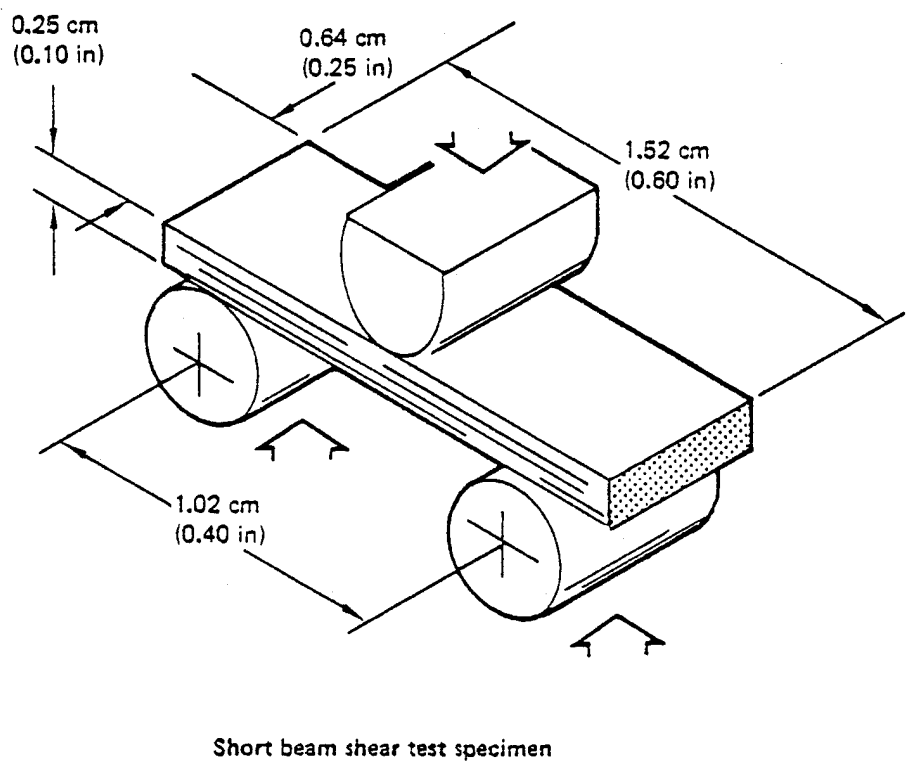
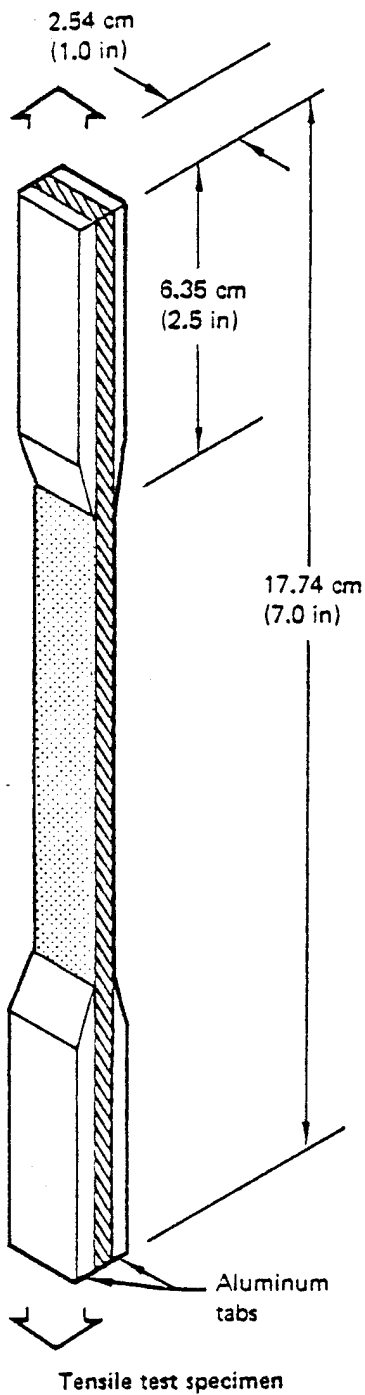

Figure 3. Tension and Shear Test Specimen Configurations

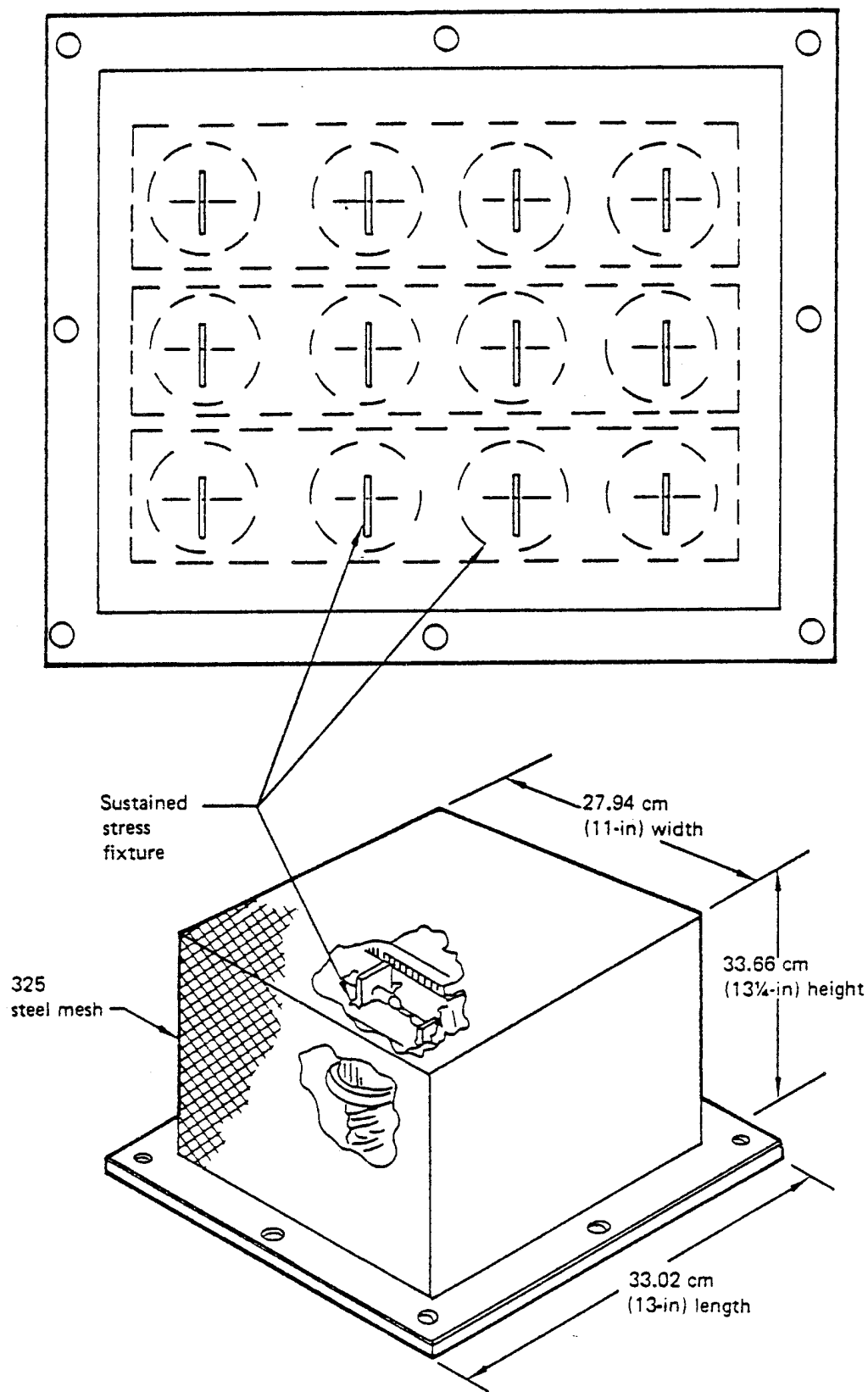

Figure 4. Fixture for Sustained Tension Loads

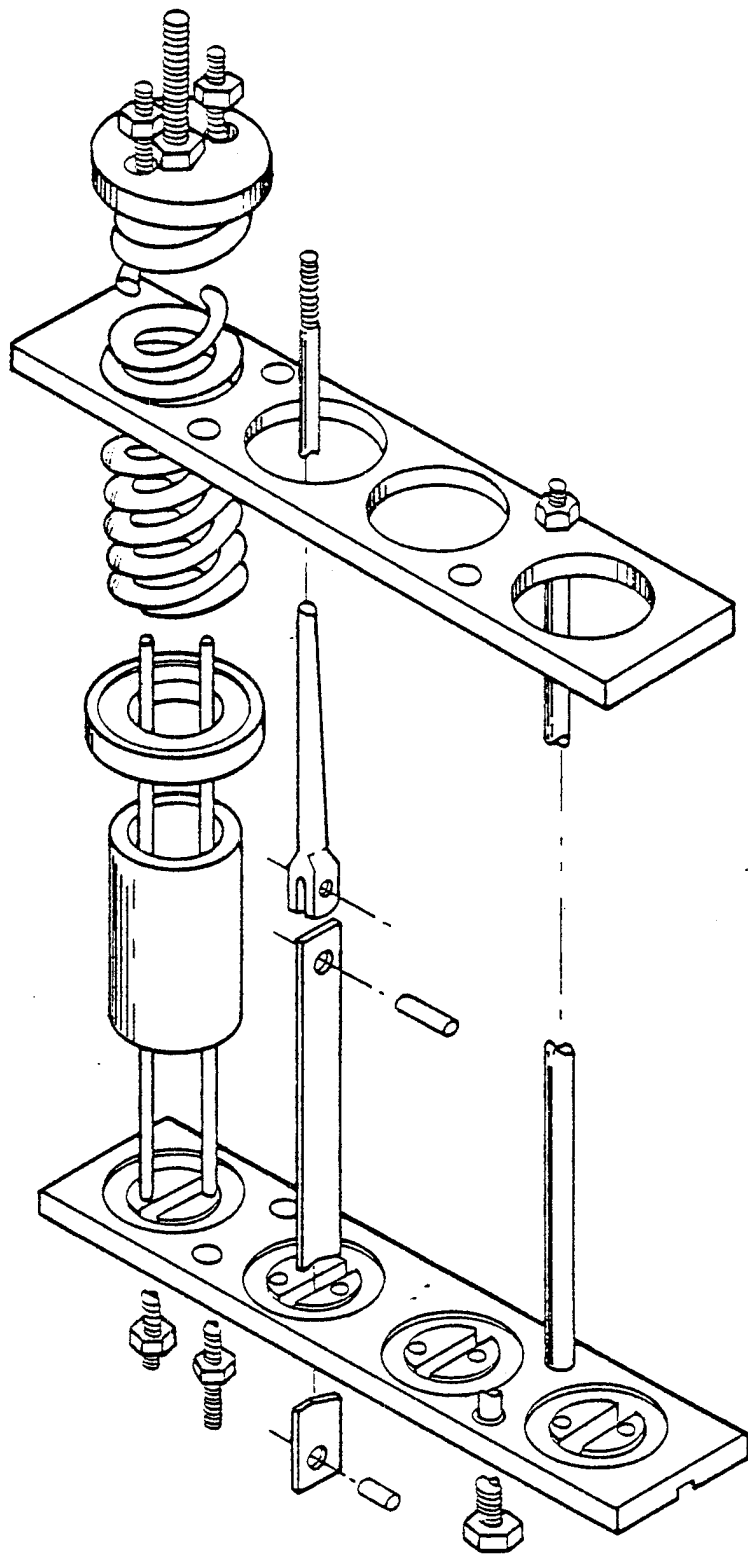

Figure 5. Sustained Stress Fixture

3.0 RESULTS AND DISCUSSION

3.1 PREPREG AND LAMINATE PHYSICAL PROPERTIES

As shown in the work flow diagram (fig. 1), the physical properties of the prepreg were conducted by the supplier. Results of the prepreg tests are shown in Table 3. The laminate physical properties of each fiber/resin system were determined in-house; these results are shown in Table 4. Improper bleed out of the 2544 resin resulted in a greater fiber volume fraction than expected or desired. Sufficient quantities of this material were not available for proper determination of the cure cycle.

3.2 EXPOSURE TEST RESULTS

The following results were obtained on each fiber/resin system shown below after 5 years of exposure.

450 K (350°F) Cure, T300 Graphite/5208

- o No significant reduction in tensile strength was found in either the stressed or unstressed tensile specimens when exposed to any of the environments (Fig. 6)
- o The stressed tensile modulus increased 10 to 30 percent during the latter part of the environmental exposure. There is also an increase in the unstressed modulus reported for specimens subjected to fuel/air cycling and water immersion during the last two years. The data is definitely questionable. The experimental data was reviewed and the calculations checked. The erroneous data was caused by changes in personnel, equipment or procedures over a five year period. It was probably caused by an equipment malfunction. (Fig. 7).
- o Specimens immersed in water and in fuel/water solution showed 25 to 30% reduction in short beam shear strength in the fifth year of exposure. About a 5 to 10% reduction in short beam shear strength was found for the specimens exposed to the other environments (Fig. 8).

Table 3. Prepreg Physical Properties

Fiber/epoxy system	Resin content, %	Volatile content, %
T300/5208	45	0.3
T300/5209	40 ±2	3 (max)
Kevlar 49/2544	40 ±3	2.1
Kevlar 49/5209	43	1.3

Table 4. Laminate Physical Properties

Fiber/epoxy system	Specimen type	Resin content, % by weight	Fiber volume, %	Density
T300/5208	Tensile	—	64.6	—
	Short beam shear	—	69.8	—
T300/5209	Tensile	—	—	—
	Short beam shear	25.8	66.8	1.58
Kevlar 49/2544	Tensile	15.4	76.6	1.37
	Short beam shear	—	78.0	—
Kevlar 49/5209 style 281 fabric	Tensile	—	62.4	—
	Short beam shear	—	67.0	—

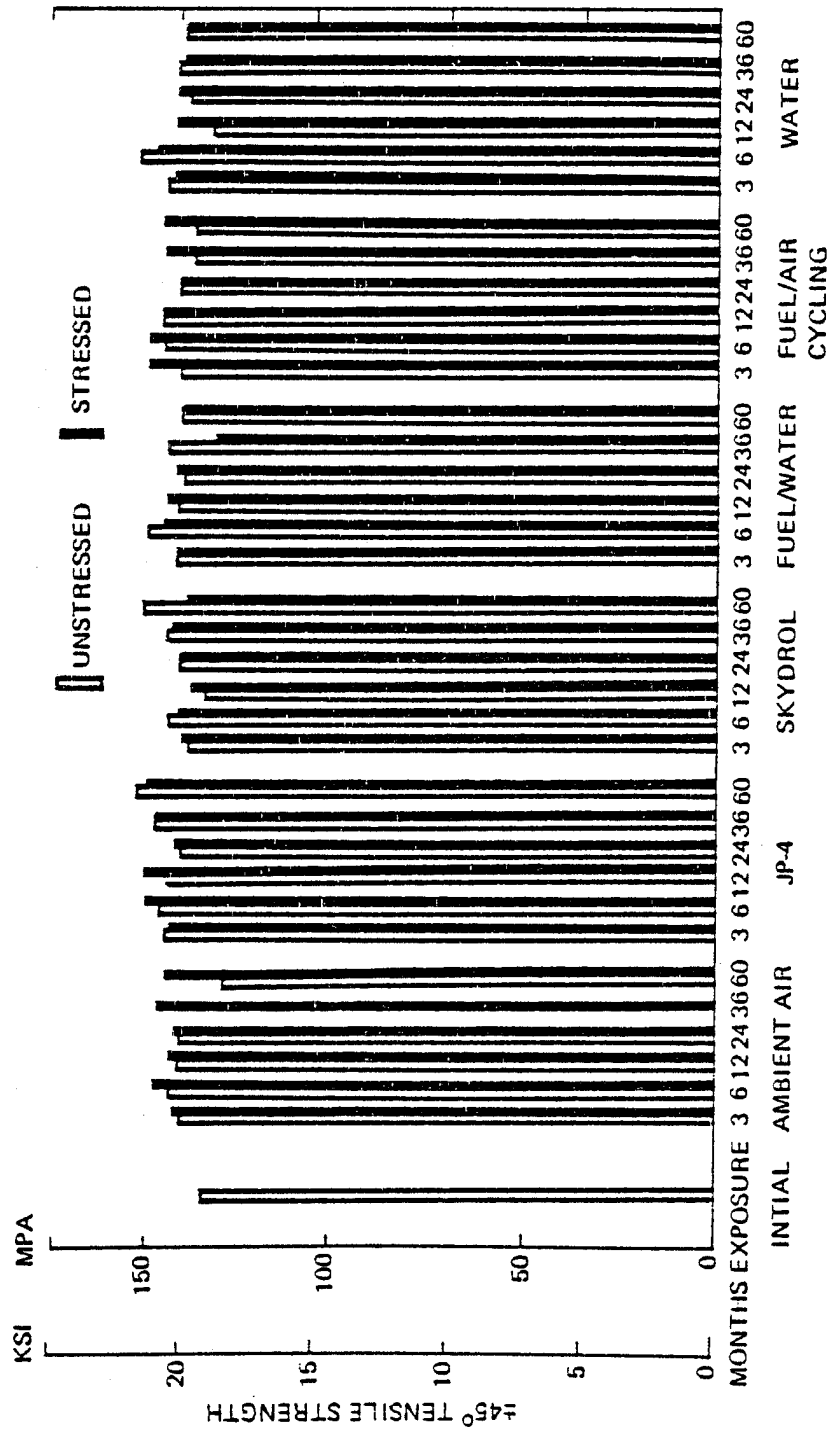

Figure 6. Environmental Exposure of T300/5208 ($\pm 45^\circ$ Tensile Strength, $V_F = 64.6$)

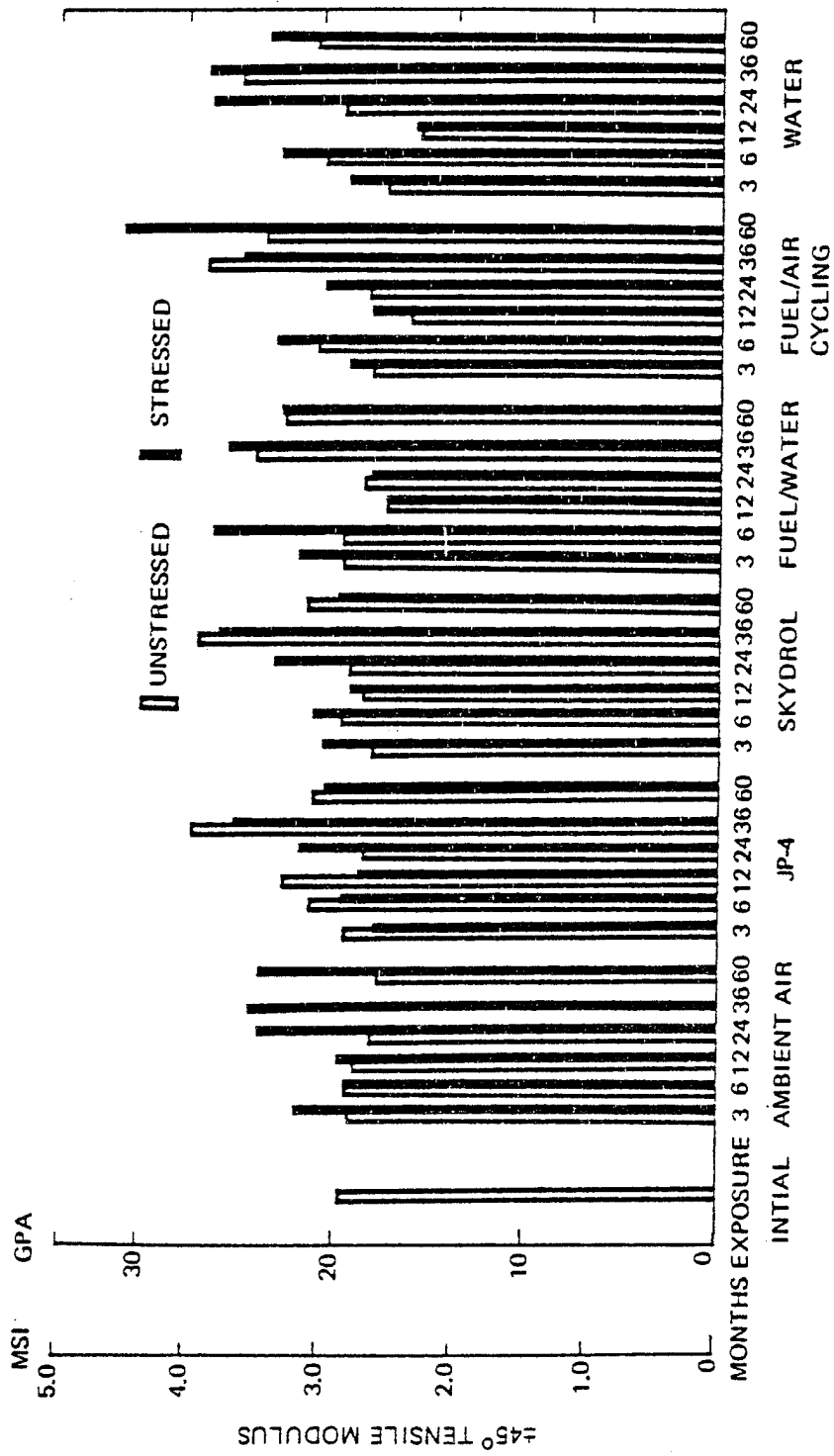
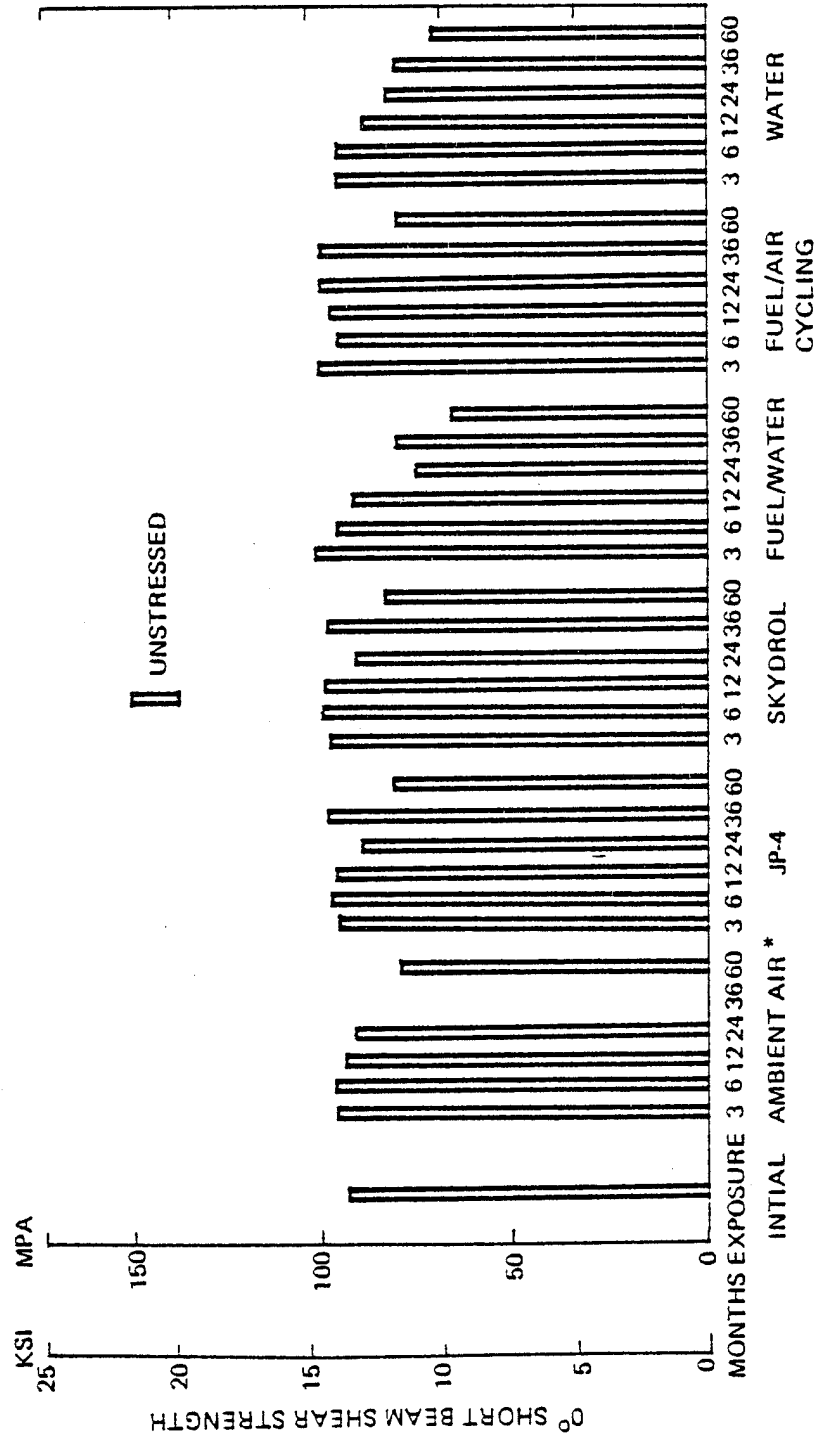

Figure 7. Environmental Exposure of T300/5208 ($\pm 45^\circ$ Tensile Modulus, $V_F = 64.6$)



* Lost ambient air specimens at 36 months.

Figure 8. Environmental Exposure of T300/5208 (0° Short Beam Shear, $V_F = 69.8\%$)

394 K (250°F) Cure, T300 Graphite/5209

- o A maximum of 10% reduction in tensile strength was found for the stressed and unstressed tension specimens when exposed to any of the environments (fig. 9).
- o Again, there are 10 to 50 percent increases in the stressed and unstressed tensile modulus (Fig. 10). The increases in tensile modulus are not as prevalent as with the previous material (T300/5208); however, the increases approach fifty percent of the initial value. The cause was probably an equipment malfunction.
- o Specimens immersed in fuel/water solution showed a 40% reduction in short beam shear strength after the third year of exposure. All other short beam shear specimens exposed to the other environments also showed a 10 to 20% reduction in strength after the fifth year of exposure (fig. 11).
- o No water immersion test was conducted on this fiber/resin system.

450 K (350°F) Cure, Kevlar 49/2544

- o Tensile specimens (stressed and unstressed) immersed in fuel/water solution showed a rapid decrease in tensile strength (approximately 20%) within the first year of exposure. However, no additional reduction occurred throughout the 5-year exposure period. All other exposures showed no significant effect on the tensile properties (figs. 12), except for a 20% strength reduction in unstressed tension specimens exposed to fuel/air cycling.
- o The tensile modulus data for this composite system are shown in Figure 13. There is some variation in the modulus but the variation is not significant.
- o Short beam shear specimens immersed in fuel/water solution showed a rapid 70% reduction in interlaminar shear strength at the end of 6 months exposure. At the same time, fuel/air cycling resulted in a 35% reduction in interlaminar shear strength. All other exposure conditions had no effect on the interlaminar shear strength of this system (fig. 14). The fiber volume fraction of the Kevlar 49/2544 composite is greater than expected or desired. The low matrix resin volume fraction causes localized defects because of resin starvation. This is the

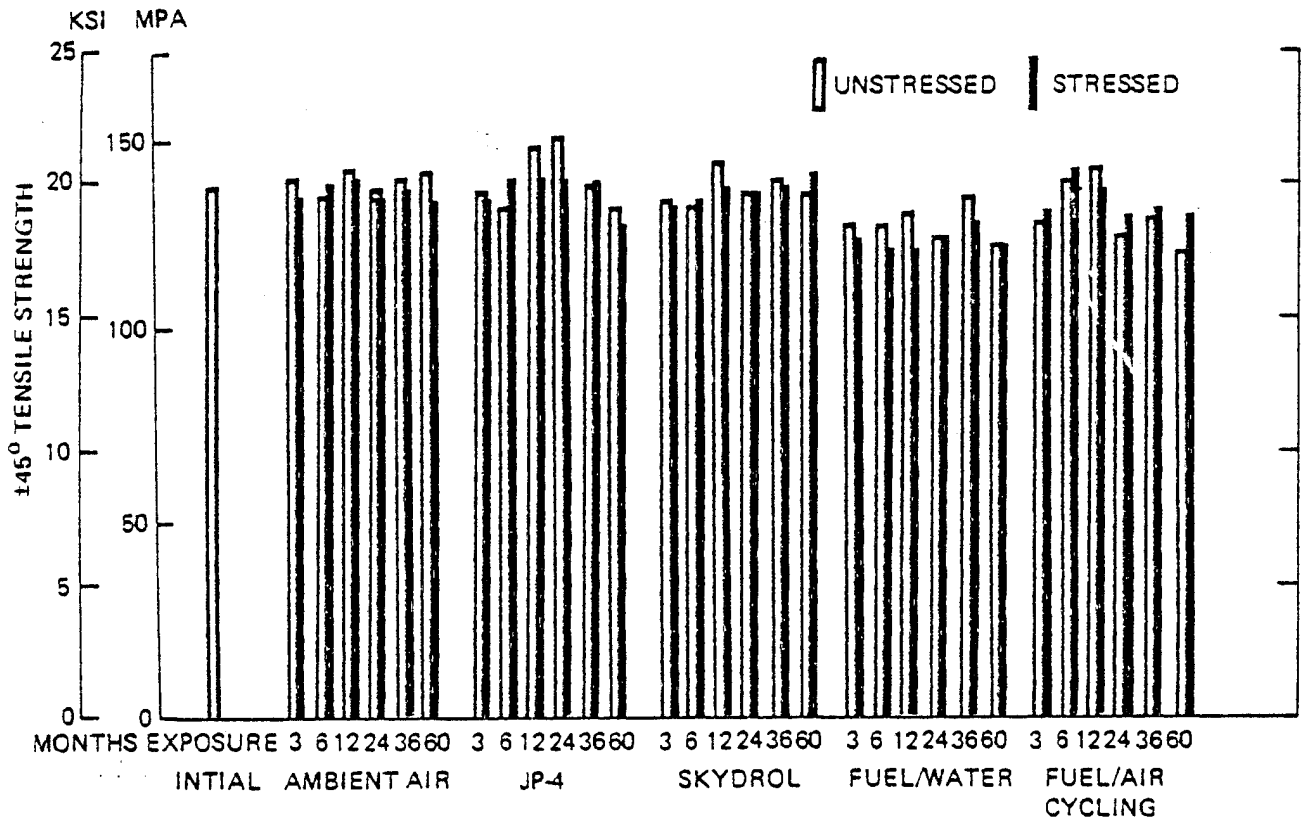

Figure 9. Environmental Exposure of T300/5209 ($\pm 45^\circ$ Tensile Strength, $V_F = 66.8\%$)

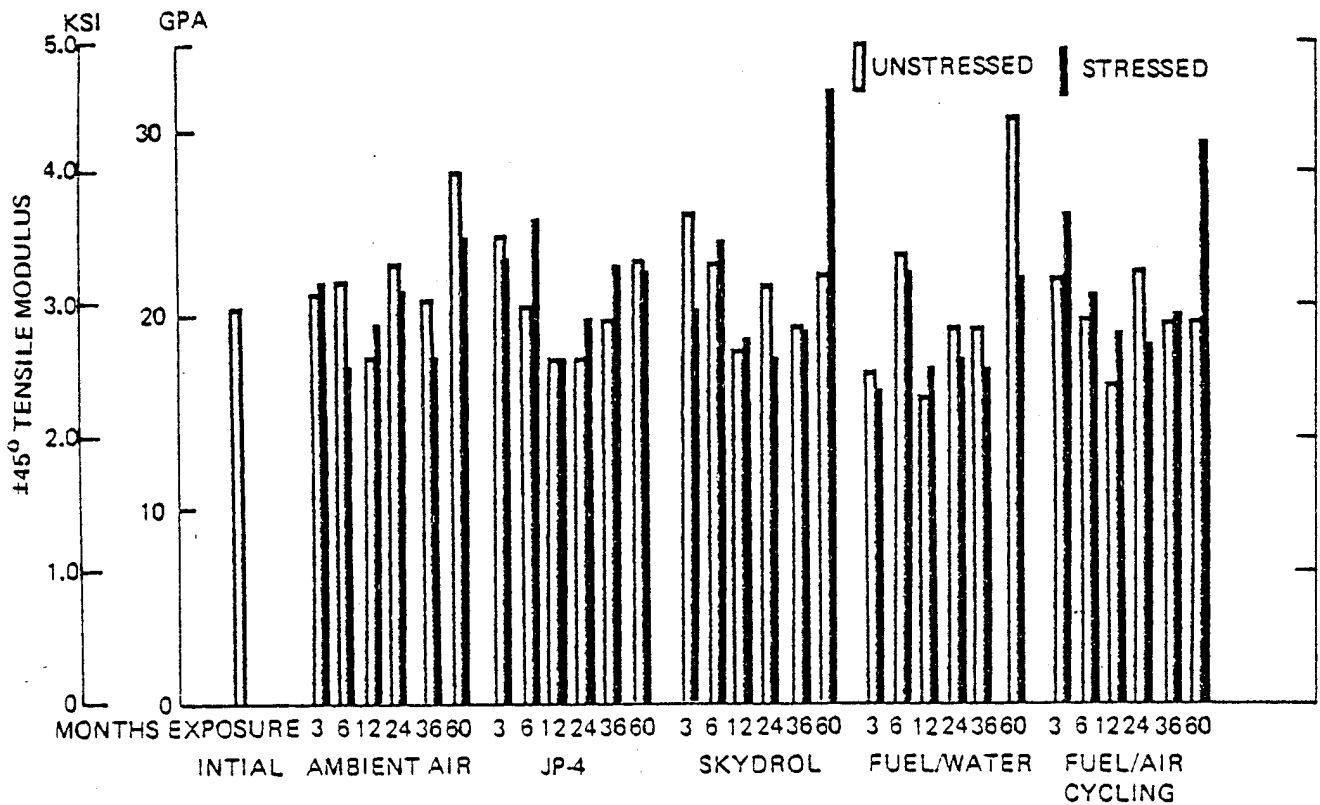

Figure 10. Environmental Exposure of T300/5209 ($\pm 45^\circ$ Tensile Modulus, $V_F = 66.8\%$)

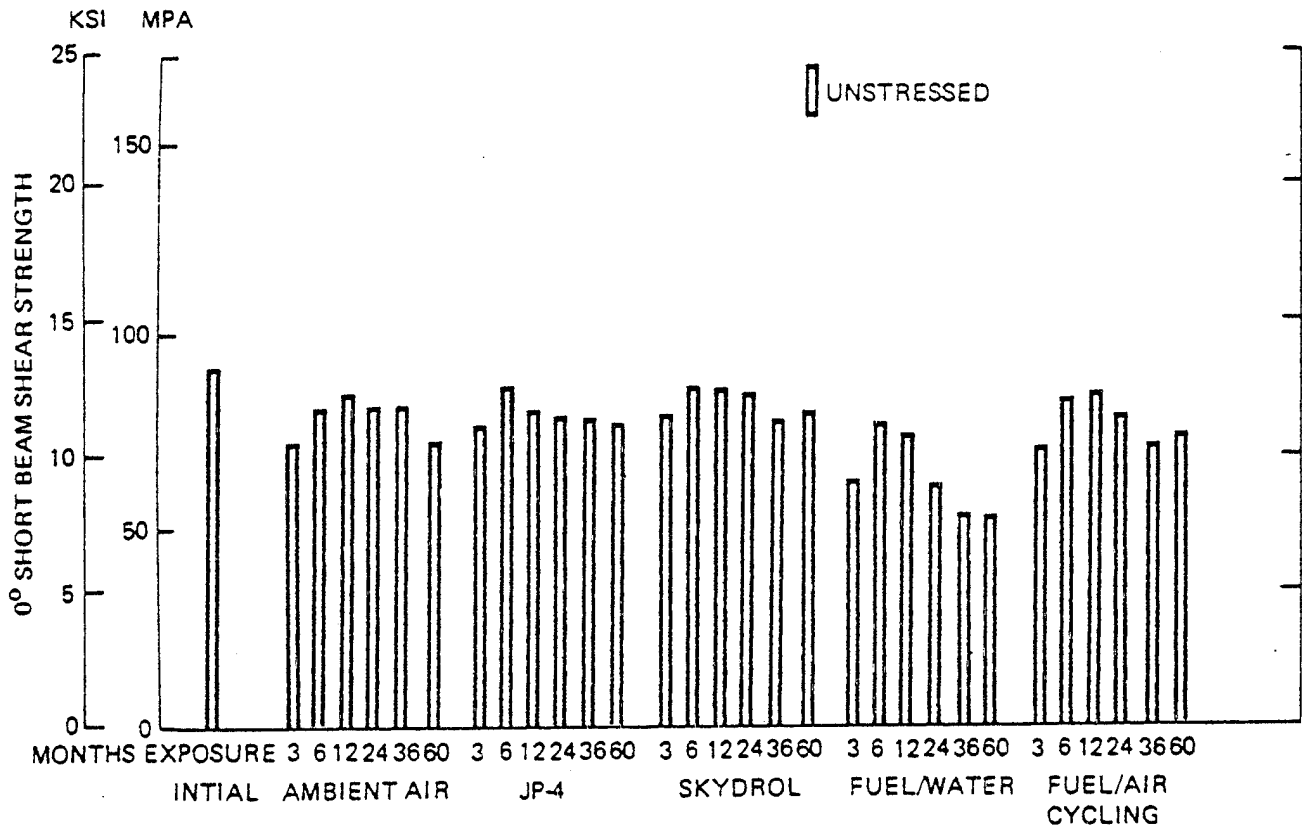

Figure 11. Environmental Exposure of T300/5209 (0° Short Beam Shear, $V_F = 66.8\%$)

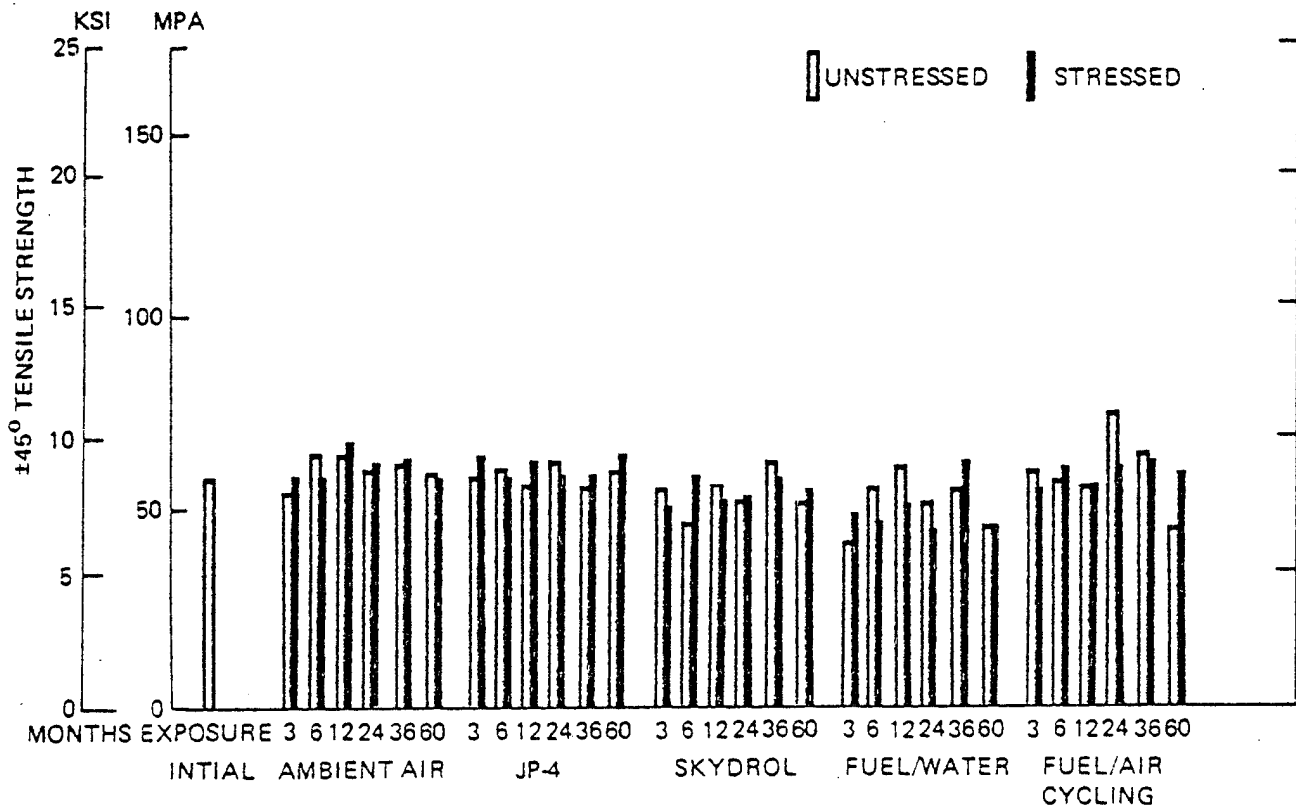

Figure 12. Environmental Exposure of Kevlar 49/2544 ($\pm 45^\circ$ Tensile Strength, $V_F = 78.2\%$)

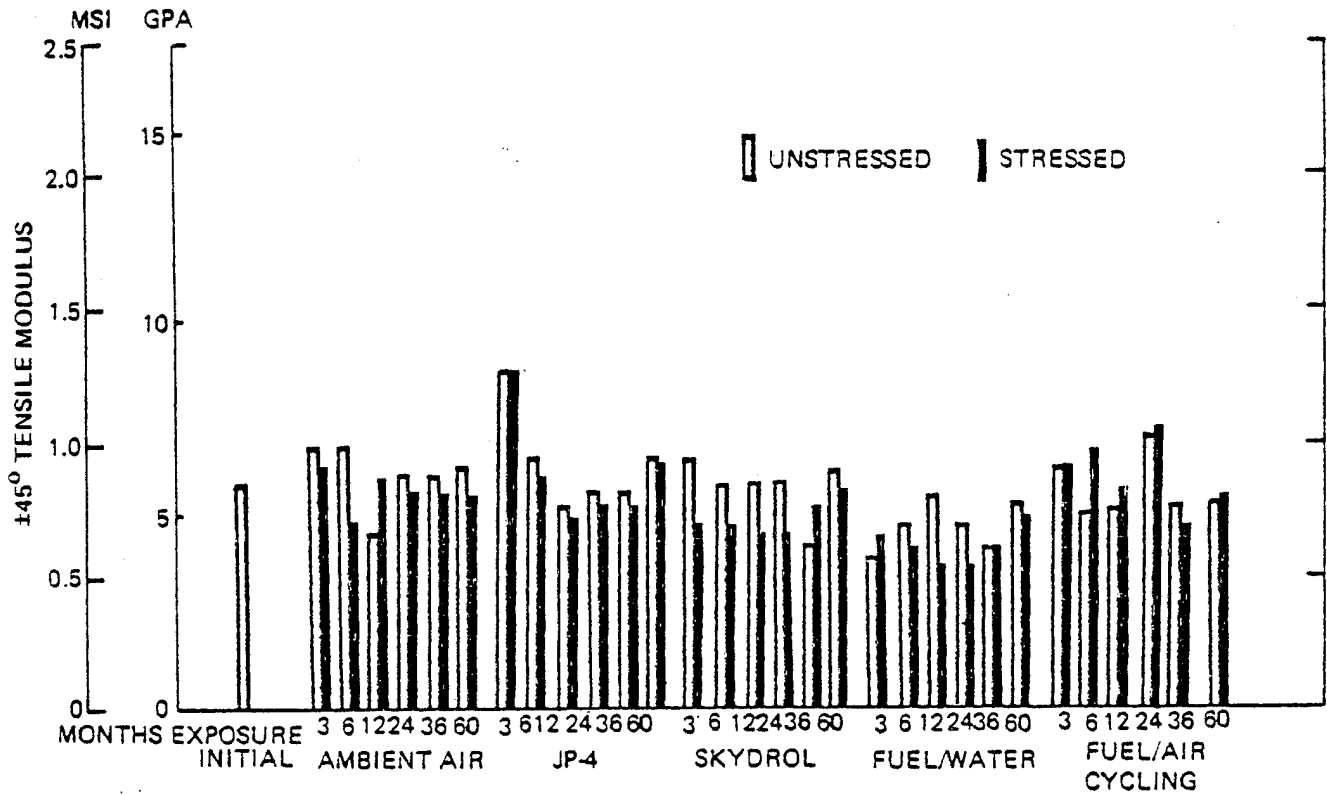

Figure 13. Environmental Exposure of Kevlar 49/2544 ($\pm 45^\circ$ Tensile Modulus, $V_F = 78.2\%$)

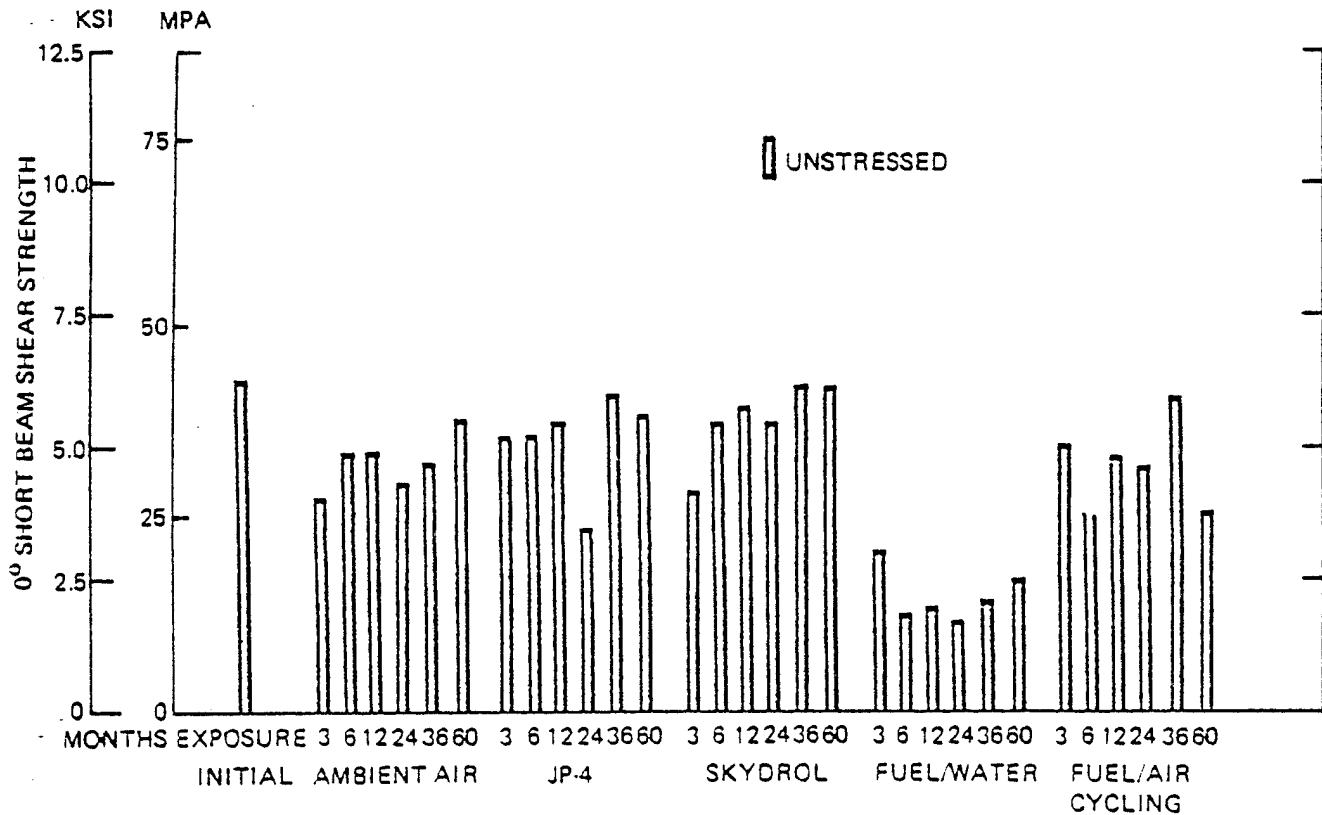

Figure 14. Environmental Exposure of Kevlar 49/2544 (0° Short Beam Shear, $V_F = 64.2\%$)

cause of the erratic short beam shear strength.

- o No water immersion test was conducted on this fiber/epoxy system.
- o The low matrix resin volume fraction of the Kevlar 49/2544 system has resulted in structural defects which were caused by random resin starvation. The mechanical properties of this system fluctuate more than any of the other composite materials because of the random structural defects.

394 K (250°F) Cure, Kevlar 49/5209

- o Tensile specimens (stressed and unstressed) immersed in water and in fuel/water solution showed a rapid decrease in tensile strength (approximately 25 to 35%) within the first year of exposure. The reduction, however, plateaued and no additional reduction occurred throughout the 5-year exposure period. Except for the stressed tensile specimen exposed in ambient air, all of the other tensile specimens (stressed and unstressed) showed a rapid, 10 to 20% tensile strength reduction after 6 months of exposure. Again, these reductions plateaued and no additional reduction occurred throughout the 5-year exposure period (Fig. 15).
- o The tensile modulus data for this composite system are shown in Figure 16. There is some variation in the modulus data, but the variation is not significant.
- o Short beam shear specimens immersed in water and in fuel/water solution showed a 25 to 30% interlaminar shear strength reduction. This reduction occurred within 2 years, plateaued, and remained at this level throughout the 5-year exposure period. No significant reduction in interlaminar shear strength occurred for any of the other exposures (Fig. 17).

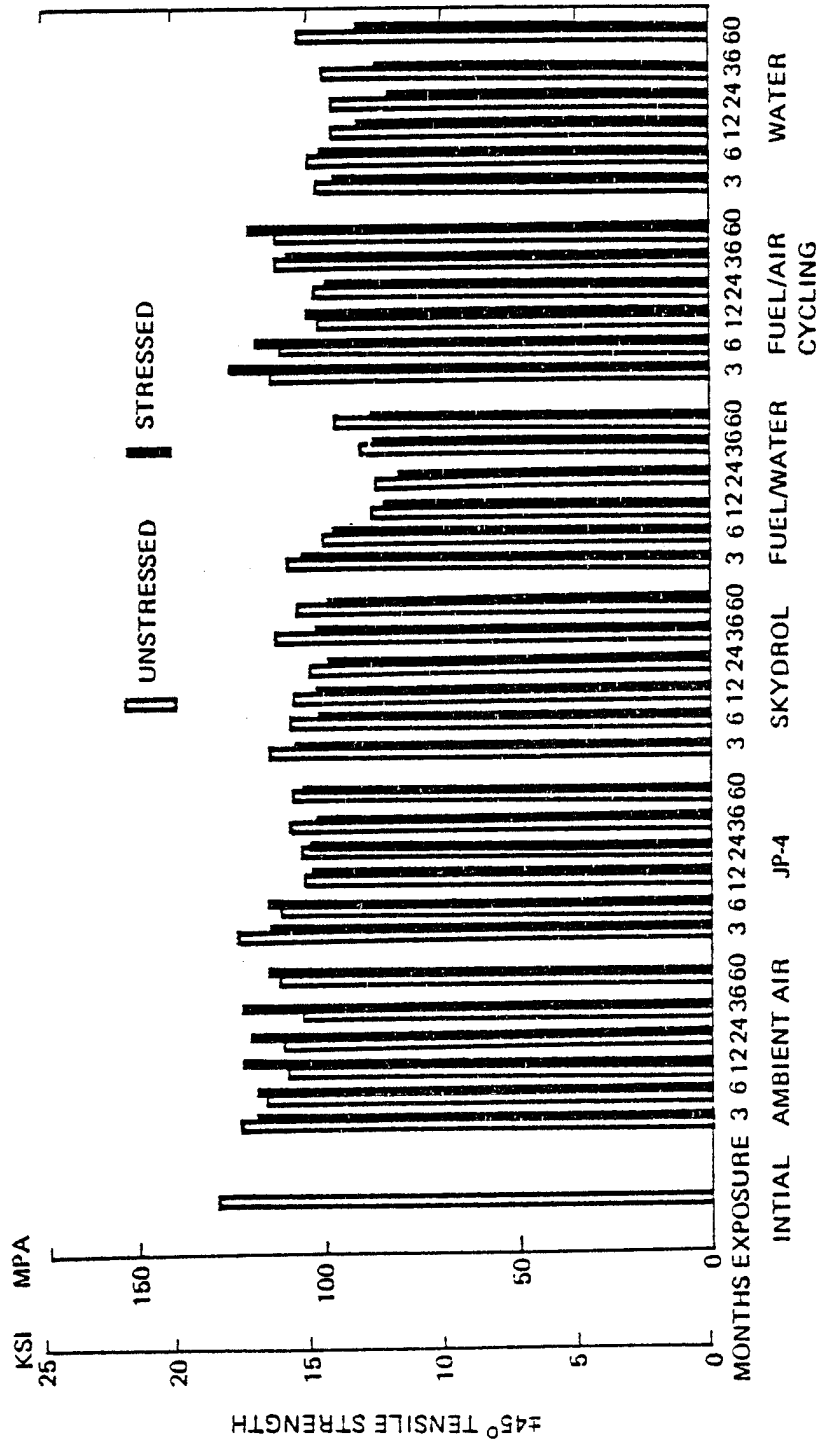

Figure 15. Environmental Exposure of Woven Kevlar (281)/5209 ($\pm 45^\circ$ Tensile Strength, $V_F = 64.4\%$)

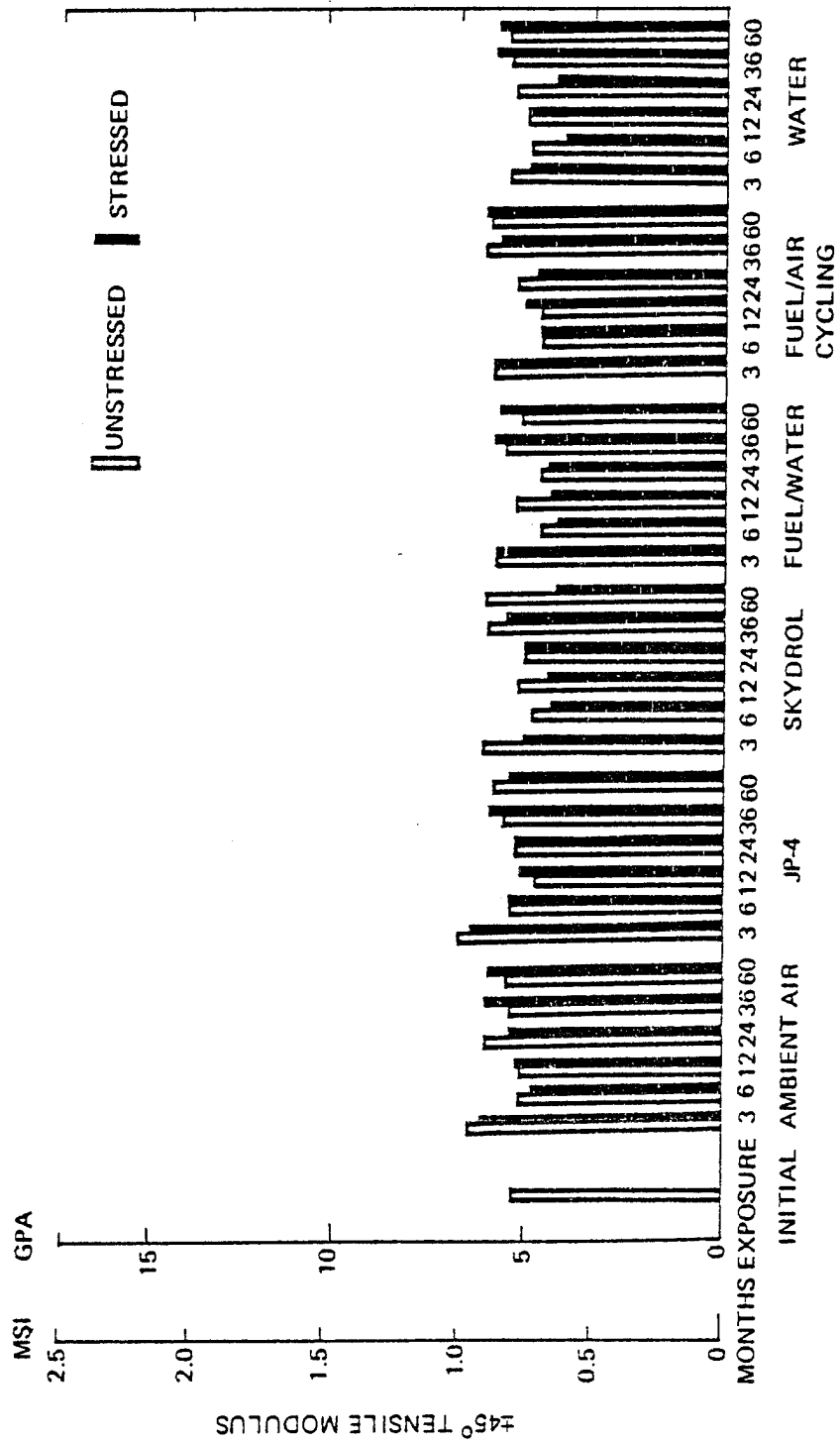

Figure 16. Environmental Exposure of Woven Kevlar (281)/5209 ($\pm 45^\circ$ Tensile Modulus, $V_F = 64.4\%$)

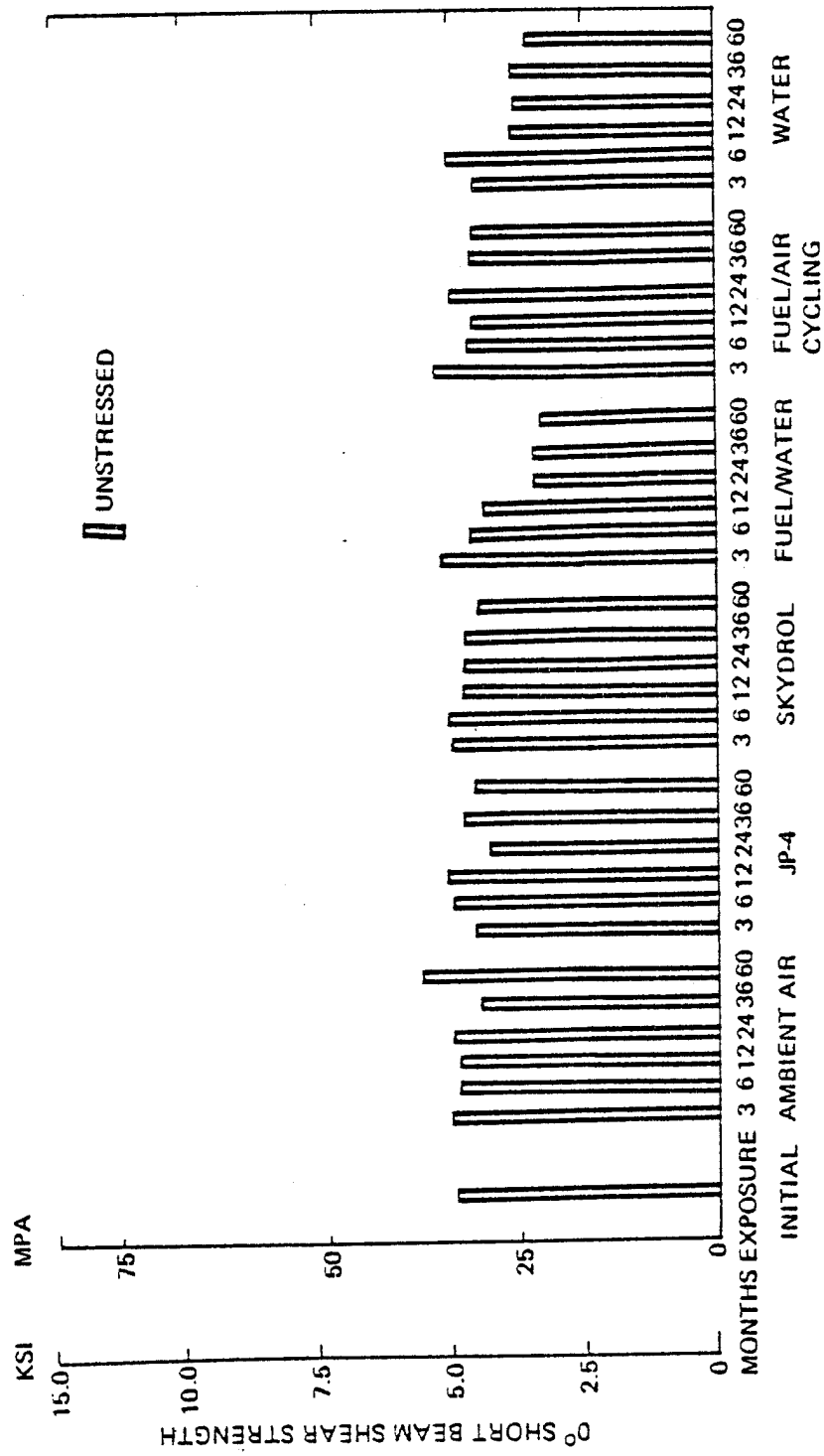

Figure 17. Environmental Exposure of Woven Kevlar (281)/5209 (0° Short Beam Shear, $V_F = 67.0\%$)

Bare Kevlar 49 Fibers

The effects of water on individual Kevlar 49 fiber strength are shown in Table 5 and Figure 18. The graph indicates a gradual steady decrease of up to 25% reduction in tensile strength. However, it should be noted that a high data coefficient of variation was experienced as shown by the data scatter for each exposure period. The resulting curve shown on Figure 18 is a least squares fit of the experimental data.

Measurement of the mechanical properties of individual Kevlar fibers is difficult for the following reasons:

1. The diameter of the fibers cannot be measured accurately.
2. It is very easy to damage the outer layer of the fiber which carries most of the load.
3. Length and width gage effects affect the mechanical properties of individual fibers.
4. Alignment and gripping of individual fibers during mechanical testing is very difficult.

The variation in the mechanical strength of the fibers is too great. However, considering the experimental difficulties, the results are not unexpected.

The modulus data for the individual fibers are shown in Table 5. For all practical purposes, the variation in the modulus is reasonable. The variation in the modulus is consistent with the accuracy to which it was measured.

3.3 DISCUSSION

Results indicate that the water or water-based fluids are more degrading to strength than the nonaqueous fluids in all fiber/epoxy systems tested in this program. This result supports the argument and work done by Judd (ref 1). This difference in behavior between aqueous and nonaqueous fluids is probably associated with the polar

Table 5. Mechanical Properties of Individual Kevlar 49 Fibers

	Water immersion						
	Initial	3 mo	6 mo	12 mo	24 mo	36 mo	60 mo
Tensile strength GPa, ksi	3.43 (497) 1.56 (226) 1.57 (227) 2.17 (315) 3.34 (484) 2.95 (428) 2.95 (428) 3.30 (478) 3.68 (534) 2.69 (390)	2.43 (352) 2.43 (353) 2.69 (390) 2.86 (415) 2.48 (359) 2.04 (296) — 2.34 (340) 2.30 (334) 2.78 (403)	3.19 (462) 3.32 (481) 2.30 (333) 2.68 (388) 2.82 (409) 3.32 (481) 2.01 (291) 4.78 (693) 1.89 (274) 3.25 (471)	3.16 (459) 2.34 (340) 3.16 (459) 1.74 (252) 2.30 (334) 3.43 (497) 3.16 (459) 3.52 (510) 2.17 (315) 1.43 (208)	2.00 (290) 2.10 (305) 2.08 (301) 3.73 (541) 1.65 (240) 1.77 (256) 1.59 (231) 1.54 (223) 2.63 (381) 1.21 (176)	2.20 (319) 3.47 (503) 1.63 (236) 3.44 (499) 1.68 (243) 1.69 (245) 2.45 (355) 1.74 (252) 3.34 (485) 1.86 (270)	2.63 (381) 2.77 (402) 1.91 (277) 1.84 (267) 2.92 (424) 2.54 (368) 1.91 (277) 3.30 (478) 2.53 (367) 1.43 (208)
Coefficient of variation	2.76 (400.7) 27.5%	2.48 (360) 10.3%	2.96 (428) 28.3%	2.64 (383) 28.0%	2.03 (294) 35.1%	2.35 (341) 33.2%	2.38 (345) 21.1%
Tensile modulus GPa, Msi	86.2 (12.5) 90.3 (13.1) 107.6 (15.6) 96.5 (14.0) 95.2 (13.8) 104.8 (15.2) 114.5 (16.6) 108.9 (15.8) 102.7 (14.9) 106.2 (15.4)	106.2 (15.4) 97.9 (14.2) 100.7 (14.6) 90.3 (13.1) 100.7 (14.6) 117.9 (17.1) — 104.8 (15.2) 91.7 (13.3) 102.0 (14.8)	153.1 (22.2) 102.7 (14.9) 104.1 (15.1) 102.0 (14.8) 98.6 (14.3) 100.0 (14.5) 100.0 (14.5) 187.5 (27.2) 80.7 (11.7) 95.8 (13.9)	124.8 (18.1) 131.0 (19.0) 111.0 (16.1) 106.2 (15.4) 111.0 (16.1) 109.0 (15.8) 110.3 (16.0) 102.0 (14.8) 118.6 (17.2) 92.4 (13.4)	97.9 (14.2) 93.7 (13.6) 107.6 (15.6) 104.8 (15.2) 77.9 (11.3) 114.5 (16.6) 85.5 (12.4) 103.4 (15.0) 108.9 (15.8) 80.7 (11.7)	108.3 (15.7) 107.6 (15.6) 109.6 (15.9) 108.3 (15.7) 96.5 (14.0) 111.0 (16.1) 111.0 (16.1) 86.9 (12.6) 121.4 (17.6) 105.5 (15.3)	120.7 (17.5) 95.2 (13.8) 107.6 (15.6) 91.0 (13.2) 102.7 (14.9) 78.6 (11.4) 99.3 (14.4) 83.4 (12.1) 80.0 (11.6) 69.6 (10.1)
Coefficient of variation	101.3 (14.7) 8.8%	101.4 (14.7) 8.1%	112.5 (16.3) 28.7%	111.6 (16.2) 9.9%	97.5 (14.1) 12.9%	106.6 (15.5) 8.6%	92.8 (13.5) 16.6%

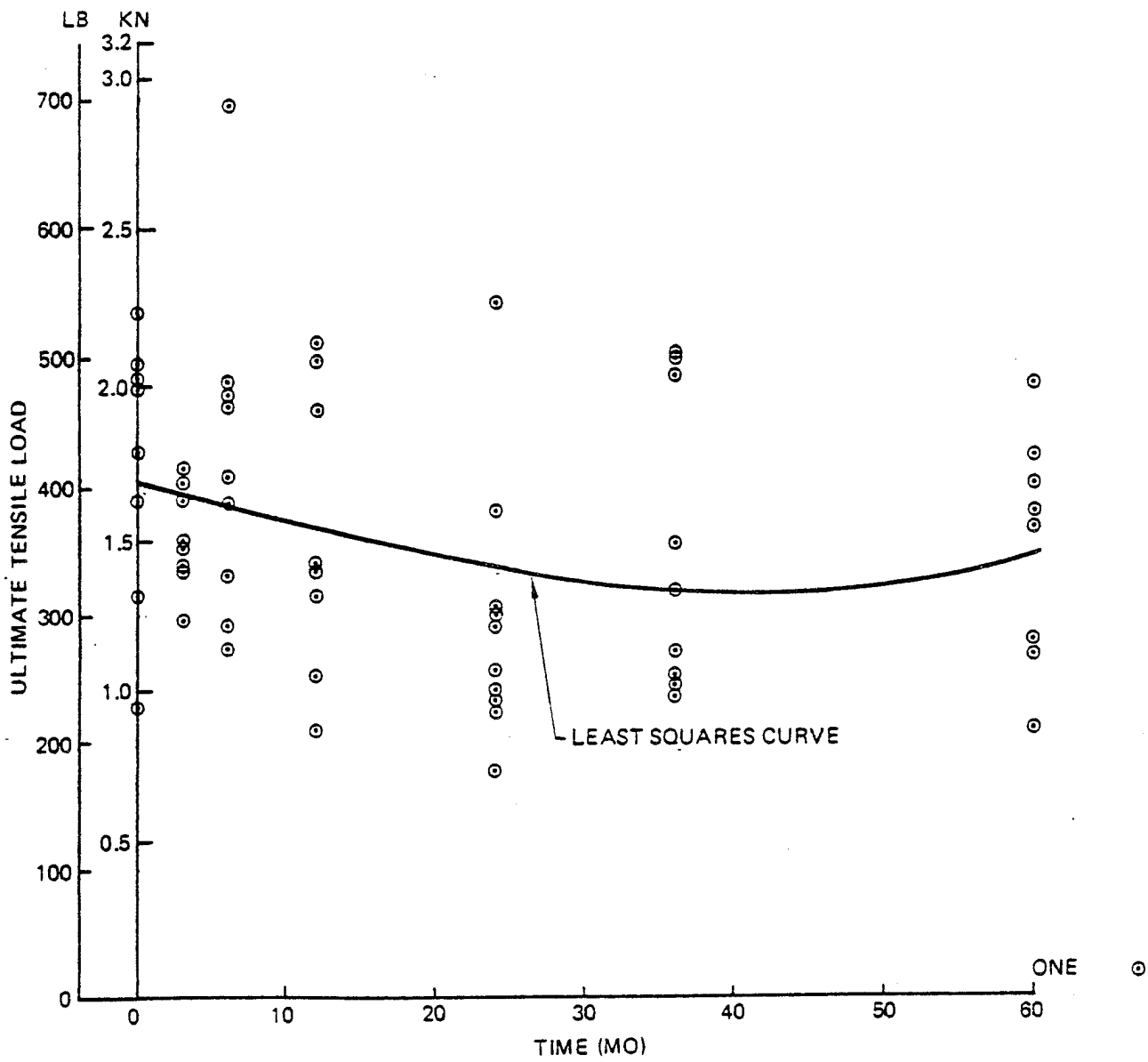

Figure 18. Tensile Results of (Unstressed) Kevlar Strands Immersed in Water

structure of the epoxy matrix resin. It is speculated that the ingress of water into the epoxy matrix, by diffusion through the resin, capillary channels, or voids, occurs at a higher rate in aqueous environments, due to both the polar nature and the relative size of the water molecules as compared to the other fluids tested in this program. It also is speculated that water molecules degrade the chemical bonds at the fiber-matrix resin interface. This theory is supported by the short-beam shear results of all fiber/resin systems tested.

Results also indicate that the graphite/epoxy systems are more resistant to environmental degradation than the Kevlar/epoxy systems. The fluids tended to affect the Kevlar/epoxy specimens after a shorter exposure period than the graphite/epoxy specimens. Kevlar fibers have a large positive coefficient of thermal expansion in the transverse direction compared to graphite fibers. The adhesion between epoxy matrix resins and graphite fibers exceeds the adhesion between epoxy matrix resins and Kevlar fibers. One theory is that these two phenomena create a larger fiber-to-matrix channel in Kevlar/epoxy composites compared to graphite/epoxy composites when the systems are cured. The larger fiber-to-matrix channel would accelerate the ingress of fluids. Accelerated absorption of fluids would cause the Kevlar epoxy composite to fail sooner than the graphite/epoxy composite.

4.0 CONCLUSIONS

The conclusions drawn from this study are based on the program limitations, which are:

- o The limited number of specimens (two per test per exposure period)
- o The type of epoxy systems tested
- o The type of mechanical test selected: +45-degree (stressed and unstressed) tensile and 0-degree short beam shear specimens
- o The exposure conditions used

Due to these limitations, quantitative conclusions cannot be drawn. However, trends have been found and the following qualitative conclusions can be made:

1. Water immersion or fuel/water immersion resulted in the greatest strength degradation for the composite systems tested in this program.
2. No significant differences were found between the +45-degree unstressed tensile specimens and the +45-degree stressed tensile specimens.
3. Both aqueous and nonaqueous solutions, showed a tendency to affect the Kevlar/epoxy systems at an earlier exposure time than the graphite/epoxy systems.
4. In general, graphite/epoxy systems were more resistant to environmental degradation than the Kevlar/epoxy systems.

REFERENCES

1. Judd, N. C. W.: "The Effect of Water on Carbon Fibre Composites," SPI Reinforced Plastics/Composites Institute, 30th Anniversary Technical Conference, 1975.