

492
4034

NASA Contractor Report 4034

Ultrasonic Determination of
the Elastic Constants of
the Stiffness Matrix for
Unidirectional Fiberglass
Epoxy Composites

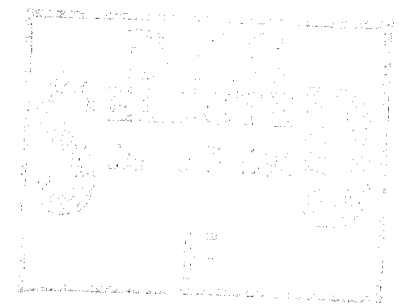

Elizabeth R. C. Marques and James H. Williams, Jr.

GRANT NAG3-328
DECEMBER 1986

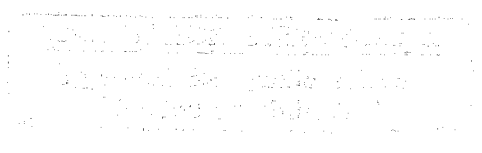

19951121 097



1986
MARQUES
WILLIAMS

NASA Contractor Report 4034

Ultrasonic Determination of the Elastic Constants of the Stiffness Matrix for Unidirectional Fiberglass Epoxy Composites

Elizabeth R. C. Marques and James H. Williams, Jr.
*Massachusetts Institute of Technology
Cambridge, Massachusetts*

Prepared for
Lewis Research Center
under Grant NAG3-328

NASA
National Aeronautics
and Space Administration

Scientific and Technical
Information Branch

1986

Accession For		
NTIS	CRA&I	<input checked="" type="checkbox"/>
DTIC	TAB	<input type="checkbox"/>
Unannounced		<input type="checkbox"/>
Justification		
By		
Distribution /		
Availability Codes		
Dist	Avail and/or Special	
A-1		

SUMMARY

The elastic constants of a fiberglass epoxy unidirectional composite are determined by measuring the phase velocities of longitudinal and shear stress waves via the through transmission ultrasonic technique . The waves introduced into the composite specimens were generated by piezoceramic transducers. Geometric lengths and the times required to travel those lengths were used to calculate the phase velocities. The model of the transversely isotropic medium was adopted to relate the velocities and elastic constants.

INTRODUCTION

Filamentary composites have proved their usefulness in modern aircraft, spacecraft, land and water vehicles, and many other structural applications.

One of the special characteristics of these materials is their anisotropic elastic behavior, that is, their elastic properties which change with orientation. Knowledge of such properties is essential both for optimal design and for evaluation of performance. Elastic properties are usually represented by a set of constants which can be determined by conventional stress-strain measurements in different loading configurations (as, for instance, in standard tensile tests) or by ultrasonic methods.

Ultrasonic testing is a nondestructive evaluation (NDE) technique in which the propagation characteristics of stress waves in a material are determined. The wave transmission characteristics may then be related to such factors as the elastic properties of the material or the presence of flaws. Ultrasonic methods have been extensively used for the determination of velocities of stress waves, elastic constants of the stiffness matrix, fiber fraction, degree of fiber orientation, presence of voids, and attenuation and damping parameters [1-6]. One of the main advantages of ultrasonic methods, as they are essentially nondestructive, is their suitability for the evaluation of "in service" components.

The purpose of this work is to establish the experimental values of the velocities of ultrasonic waves of a specific

composite laminate of fiberglass epoxy in which the fibers are continuous and unidirectional. From the measured velocities, the values of elastic constants of the stiffness matrix are determined. Such parameters can then be used both for design purposes or as standards for the NDE evaluation of the performance of components.

TRANSVERSELY ISOTROPIC COMPOSITE

In filamentary composite materials, the presence of a distinctive fiber orientation gives rise to elastic anisotropy. Unidirectional fiber composites consist of a parallel set of cylindrical fibers embedded in an otherwise homogeneous matrix material. If the constituent materials are isotropic, the resulting composite will be classified as transversely isotropic, or hexagonally symmetric.

A transversely isotropic material can be formed from prepreg sheets of continuous parallel fibers that are layered to form a unidirectional composite [7]. A schematic of this configuration is shown in Fig.1. When the transversely isotropic model is adopted, the fibers are assumed to be randomly arranged in the xy plane.

To characterize the mechanical behavior of transversely isotropic materials, five independent elastic constants are required [8] .

BASIC PRINCIPLES

The elastic properties of a filamentary transversely isotropic composite are evaluated by measuring the phase velocities of longitudinal and shear plane waves propagating through the material at various angles with respect to the fiber direction.

Depending on the direction cosines chosen for the normal of the propagating wave, the equations yielding the five elastic constants in terms of velocities can be obtained. These equations have been derived for transversely isotropic materials [9]. For a cartesian coordinate system x , y and z in which z coincides with the fiber direction in the transversely isotropic material, the relations between the elastic constants of the stiffness matrix and phase velocities are summarized in Table 1. The propagation of waves in any direction or polarization direction of a wave is represented by its direction cosines with respect to the x , y , and z directions (for example $(1,0,0)$ defines the x direction). P denotes an imposed longitudinal wave, for which propagation and polarization directions are coincident; SH denotes an imposed shear wave with polarization in the y axis ; and SV denotes imposed shear wave with polarizaton in the x - z plane.

The constants C_{11} , C_{33} , C_{44} and C_{66} can be determined by direct measurement of the velocities of appropriate waves propagating in the principal directions x , y and z . The remaining constant, C_{13} , can be determined for a wave propagating along an intermediate direction between the axes x

and z . (Table 1 shows the equations for some intermediate directions, defined by their angles with respect to the z axis.)

The constant C_{12} can be calculated from C_{11} and C_{66} as $C_{12} = C_{11} - 2C_{66}$.

The model adopted describes the composite as homogeneous, so the density is assumed to be constant. The model is valid for stress waves having wavelengths that are large compared with the thickness of the prepreg sheets. Previous studies [10,11] have shown that waves can be scattered by reflection if the wavelengths have dimensions comparable to the thickness of the lamina or the fiber diameter. Effects of dispersion may be present in such cases, and a better model ought to be a layered medium model instead of the homogeneous model.

For the homogeneous model, the correspondence between the elastic constants of the stiffness matrix and the magnitudes of extensional moduli, shear moduli, and Poisson's ratios are shown in Table 2.

For composites with symmetries other than hexagonal, the procedure of measuring velocities can also be used, but in these cases a different set and number of independent elastic constants must be determined . It would be possible to determine the symmetry axes (if any) of any specimen by making sufficient measurements. This would involve a large amount of experimental work and analysis which could be greatly reduced if some prior information is known about the symmetries of the material.

EXPERIMENTAL PROCEDURES

Procedures and Equipment

The measurements were made by the through transmission technique using specimens of different lengths for each of the measurement directions. A schematic of the measuring system is shown in Fig.2 . The system consisted of a pulsed oscillator (Arenberg model PG-652) for generating sinusoidal waves , a low frequency inductor (Arenberg model LFT-500), two broadband (0.1 to 3.0 MHz) transducers (AET model FC-500) for longitudinal waves with approximately flat sensitivity of -85 dB (relative to 1V/Bar), two transducers (Panametrics model V154) for shear waves with nominal resonance of 2.25 MHz , an oscilloscope (Tektronix model 455) , auxiliary attenuators , and a pneumatic fixture that provides constant pressure between transducers and specimen interfaces. Couplants AET SC-6 and Panametrics SWC were used at interface of transducers and specimens for longitudinal and shear tests respectively.

The transmitting transducer is excited with a tone burst voltage signal of amplitude 100 Volts (peak to peak); this signal imposes a stress wave (assumed plane) onto the specimen. After travelling through the specimen, the signal is captured by the receiving transducer and displayed on the oscilloscope.

The velocity measurements of ultrasonic waves in the through transmission configuration may be affected by many parameters, including the transducer-specimen interface pressure, the mechanical properties and thickness of the couplant, the

alignment between the specimen and the transducer, the nonparallelism of the faces of the specimen and the inherent time delay of the electrical system. To avoid these effects, the following steps were taken:

a) The specimen was very carefully centered on the transducer face.

b) The interface pressure was maintained at 4.2 Bar during all the tests. This value is slightly above the saturation pressure [5] and guarantees a stable output.

c) The specimens were machined within established tolerance levels for parallelism between faces .

d) To evaluate the velocity ,the time shift between the same individual cycle of the input and ouput signals was measured. A typical example of the input and ouput signals is shown in Fig.3. A few leading cycles were not used because of their transient nature. In order to cancel the inherent time delay due to the electrical system, otherwise identical specimens of different lengths were used. If the time shifts for specimens of lengths L_i are t_i , respectively, the phase velocity v can be expressed as

$$v = (L_2 - L_1)/(t_2 - t_1) \quad (1)$$

The tests were conducted at different input frequencies: 0.28, 0.50 ,1.0, 1.5 and 2.0 MHz . The selected frequency range depended on the frequency range of operation of the transducers and on the purpose of application of the values measured.

Specimens

The material used was 3M Scotchply 1002, continuous glass fiber (type E) in a 165°C (329°F) curing epoxy matrix. The composite was cured in a heated press at 0.69 MN/m² (100 psi) according to 3M specifications [12]. The resulting resin content was 36 percent by weight. Initially a 25.4 mm (1 in) thick plate with dimensions 355.6mm x 279.4 mm (14in x12in) was fabricated. After removing the edges (approximately 10 mm), the specimens were cut from the plate with a diamond saw. The positions of the specimens with respect to the longitudinal axis of the plate (z) are shown in Fig .4 .

The cross-sectional dimensions were, based on previous experience [5,13], smaller than the diameter of the transducers faces. All cross-sections were square with 12.7 mm (0.5 in) sides.

The length to be traversed by the waves, ranged from 5mm (0.19in) to 29.6 mm (1.06in). These dimensions were limited by the geometry of the original plate and the positions of the specimens with respect to the longitudinal axis of the plate . Attention was given to the degree of parallelism of the final surfaces rather than to the dimensions , since the last could be measured a posteriori for the velocity calculations. The degree of parallelism (along the length) was maintained better than ±.013 mm (±.0005in) on all specimens.

Since the velocities are to be measured in 5 different directions with respect to the longitudinal axis of the plate (0°, 30°, 45°, 60°, 90°), at least 10 specimens (2 specimens

per direction) would be required to make all the measurements .
However, to allow for possible errors and variations in the
material, three specimens of different lengths were used for each
of the directions.

RESULTS

The times measured for the waves to travel through a certain thickness of material were found to be independent of the frequency for each of the investigated directions. This finding shows that the material is nondispersive in the frequency range used. The wave speeds were calculated from the time measurements in each direction, and the results were averaged. The confidence level of time measurements is 95 percent. The results are shown in Table 3.

The largest values for the velocities occurred for the imposed longitudinal waves, P, followed by the shear waves with polarization in the xz plane, SV, and finally by the shear waves with polarization in the y direction, SH.

For the purpose of comparison, the values of velocities along the principal directions were also calculated from layered media theory [14] and are also shown in Table 3. Table 3 shows also the percentage differences between the experimental and layered media theory values.

From the experimental values of the velocities, the elastic constants of the stiffness matrix were calculated using the expressions in Table 1. The value used for the density was 1850 kg/m^3 according to manufacturer's data [12]. The final results for the elastic constants of the stiffness matrix are shown in Table 4 with the corresponding elastic moduli and Poisson's ratios shown in Table 5. Observe that the measurements along nonprincipal directions of propagation (such as the directions 30° , 45° and 60° with respect to z) are

supposed to give values of velocities that can be used for the calculation of the same constant C_{13} (see Table 1). The apparently excessive number of measurements was done because for directions other than the principal ones (x, y and z), the error in the time measurements can be large. This is due to the fact that the directions of plane waves originally imposed onto the material are modified by a deviation effect [15], possibly introducing errors in measured times. The final value of the constant C_{13} was obtained by averaging the individual values of C_{13} calculated for each of the nonprincipal directions (30° , 45° , 60°) measured.

In general, whenever the same elastic constant of the stiffness matrix could be calculated from measurements along different directions, the final value was obtained by averaging the values obtained for that constant in each individual direction.

CONCLUSIONS

The measured phase velocities indicate that the fiberglass epoxy material tested is nondispersive for frequencies between 0.28 and 2.0 MHz.

The comparison of the experimental results with the results of layered media theory show reasonable agreement for the values of velocities of longitudinal waves. For shear waves, the percentage differences between some of the experimental and theoretical values is large.

The values of the velocities were used to calculate the elastic constants of the stiffness matrix, elastic moduli and the Poisson's ratios for the fiberglass epoxy. The values found are elastically compatible. For the compatibility of elastic properties the Poisson's ratios ν_{xy} and ν_{zx} must obey the following condition [16]

$$-1 \leq \nu_{xy} \leq 1 \tag{2}$$

$$\nu_{zx} \leq (E_x/E_z)^{1/2}$$

where E_x and E_z are the extensional moduli of the composite in the x and z directions, respectively.

REFERENCES

- [1] M.F. Markham, "Measurements of the Elastic Constants of Fibre Composites by Ultrasonics", Composites, Vol. 1, No.3, March 1970, pp. 145-149.
- [2] G.D. Dean, and J.F.Lockett, "Determination of the Mechanical Properties of Fiber Composites by Ultrasonic Techniques", Analysis of the Test Methods for High Modulus Fibers and Composites, ASTM STP 521, American Society for Testing and Materials, 1973, pp. 326-345.
- [3] G.D. Dean, "Characterization of Fibre Composites using Ultrasonics", Composites- Standards, Testing and Design, National Physics Laboratory Conference Proceedings, Middlesex, England, April 1954, pp.126-130.
- [4] R.D. Kriz, and W.W. Stichcomb, "Elastic Moduli of Transversely Isotropic Fibers and Their Composites", Experimental Mechanics, Vol.19, No. 2, Feb. 1979, pp 41-49.
- [5] J.H. Williams Jr., H.N. Hashemi, and S.S. Lee, "Ultrasonic Attenuation and Velocity in AS/3501-6 Graphite/Epoxy Composite", Journal of Nondestructive Evaluation, Vol.1, No.2, 1980, pp.137-148.
- [6] J.G. Elliot, "An Investigation of Ultrasonic Geometry Methods applied to Carbon Fibre Composite Materials", Harwell Reports, NDT 164, 1973.
- [7] B.W. Rosen, "Stiffness of Fibre Composite Materials", Composites, Vol.4, No.1, Jan. 1973, pp.16-25.
- [8] R.G. Payton, Elastic Wave Propagation in Transversely Isotropic Media, Martinus Nijhoff Publishers, The Hague, 1983.
- [9] M.J.R. Musgrave, Crystal Acoustics, Holden Day, San Francisco, 1970.

- [10] T.R. Touchert, and A.N. Guzelsu, "An Experimental Study of Dispersion of Stress Wave in a Fiber-Reinforced Composite", Journal of Applied Mechanics, Vol.39, Oct.1972, pp.98-102.
- [11] H.J. Sutherland, "Dispersion of Acoustical Waves by Reinforced Viscoelastic Material", Journal of the Acoustical Society of America, Vol.157, No.4, April 1975, pp.870-875.
- [12] "Scotchply - Reinforced Plastic Technical Data - Type 1002", 3M Company, Minnesota, May 1, 1969.
- [13] B. Doll, "Input-Output Characterization of Ultrasonic Transducers-Uniaxial Graphite Fiber Composite System", M.Sc.Thesis, Department of Mechanical Engineering, M.I.T., Cambridge, MA, Jan.1981.
- [14] J.E. White and F.A. Angona, "Elastic Wave Velocities in Laminated Media", Journal of the Acoustical Society of America, Vol. 27, No.2, March 1955, pp. 310-317.
- [15] E.R.C.Marques, J.H. Williams, Jr. and S.S.Lee, "Stress Waves in Transversely Isotropic Media: The Homogeneous Problem", Department of Mechanical Engineering", M.I.T., Cambridge, MA, (In press).
- [16] R.M. Christensen, Mechanics of Composite Materials, John Willey and Sons, New York, 1979.

TABLE 1 Relations Between Elastic Constants of Stiffness Matrix and Phase Velocities.

Propagation Direction	Direction Cosines of Normal to Wave Front	Direction Cosines of Polarization Direction of Imposed Wave	Type of Wave	Equation (**)
x	(1,0,0)	(1,0,0)	P	$C_{11} = \rho v^2$
x	(1,0,0)	(0,1,0)	SH	$C_{66} = \rho v^2$
x	(1,0,0)	(0,0,1)	SV	$C_{44} = \rho v^2$
z	(0,0,1)	(1,0,0)	SV	$C_{44} = \rho v^2$
z	(0,0,1)	(0,1,0)	SH	$C_{44} = \rho v^2$
z	(0,0,1)	(0,0,1)	P	$C_{33} = \rho v^2$
30° (*)	(1/2, 0, √3/2)	(1/2, 0, √3/2)	P	$C_{13} = [(1/3)(3C_{33} + C_{44} - 4\rho v^2)(3C_{44} + C_{11} - 4\rho v^2)]^{1/2} - C_{44}$
30°	(1/2, 0, √3/2)	(-√3/2, 0, 1/2)	SV	$C_{13} = [(1/3)(3C_{33} + C_{44} - 4\rho v^2)(3C_{44} + C_{11} - 4\rho v^2)]^{1/2} - C_{44}$
30°	(1/2, 0, √3/2)	(0, 1, 0)	SH	$C_{66} = (3)^{1/2} C_{44} - 2\rho v^2$
45°	(√2/2, 0, √2/2)	(√3/2, 0, √2/2)	P	$C_{13} = (C_{11} + C_{44} - 2\rho v^2)(C_{44} + C_{33} - 2\rho v^2)^{1/2} - C_{44}$
45°	(√2/2, 0, √2/2)	(-√2/2, 0, √2/2)	SV	$C_{13} = (C_{11} + C_{44} - 2\rho v^2)(C_{44} + C_{33} - 2\rho v^2)^{1/2} - C_{44}$
45°	(√2/2, 0, √2/2)	(0, 1, 0)	SH	$C_{66} + C_{44} = 2\rho v^2$
60°	(√3/2, 0, 1/2)	(1/3/2, 0, 1/2)	P	$C_{13} = [(1/3)(C_{33} + 3C_{44} - 4\rho v^2)(C_{44} + 3C_{11} - 4\rho v^2)]^{1/2} - C_{44}$
60°	(√3/2, 0, 1/2)	(-1/2, 0, √3/2)	SV	$C_{13} = [(1/3)(C_{33} + 3C_{44} - 4\rho v^2)(C_{44} + 3C_{11} - 4\rho v^2)]^{1/2} - C_{44}$
60°	(√3/2, 0, 1/2)	(0, 1, 0)	SH	$C_{66} + (3)^{1/2} C_{44} = 2\rho v^2$

(*) All angles are with respect to z axis.

(**) ρ represents the density and v the phase velocity in the propagation direction.

TABLE 2 Relations between Elastic Constants, Elastic Moduli and Poisson's Ratios for Transversely Isotropic Medium.

$E_x = (C_{11} - C_{12})(C_{11}C_{33} + C_{12}C_{33} - 2C_{13}^2) / (C_{11}C_{33} - C_{13}^2)$
$E_y = E_x$
$E_z = (C_{11}C_{33} + C_{12}C_{33} - 2C_{13}^2) / (C_{11} + C_{12})$
$\nu_{xy} = (C_{12}C_{33} - C_{13}^2) / (C_{11}C_{33} - C_{13}^2) \quad (*)$
$\nu_{yx} = \nu_{xy}$
$\nu_{xz} = C_{13} / (C_{11} + C_{12})$
$\nu_{zy} = \nu_{zx}$
$\nu_{zx} = -C_{13}(C_{12} - C_{11}) / (C_{11}C_{33} - C_{13}^2)$
$\nu_{zy} = \nu_{zx}$
$G_{xz} = C_{44}$
$G_{yz} = G_{xz}$
$G_{xy} = (C_{11} - C_{12}) / 2$

(*) Characterizes the contraction in the x direction when tension is applied in the y direction.

TABLE 3 Velocities for Unidirectional Fiberglass Epoxy.

Direction of Propagation	Imposed Wave Type	Velocity (m/s)		Percentage Difference Experimental
		Experimental	Layered Media Theory	
z	P	4692.8	4344.7	7.4
30° (*)	P	4181.0	---	---
45°	P	3558.7	---	---
60°	P	2940.9	---	---
x	P	2391.9	2300.8	3.8
z	SH	1550.4	1380.6	10.96
30°	SH	1521.1	---	---
45°	SH	1480.6	---	---
60°	SH	1399.5	---	---
x	SH	1343.0	1380.6	-2.7
z	SV	1586.3	2835.0	-78.72
30°	SV	1704.7	---	---
45°	SV	1836.1	---	---
60°	SV	1904.2	---	---
x	SV	1506.3	1380.6	8.34

(*) All angles are with respect to z axis.

TABLE 4 Values of Elastic Constants of the Stiffness Matrix.

Elastic Constant	Experimental Value (GN/m ²)
c_{11}	10.584
c_{12}	4.098
c_{13}	4.679
c_{33}	40.741
c_{44}	4.422
c_{66}	3.243

TABLE 5 Values of Elastic Moduli and Poisson's Ratios.

Elastic Moduli and Poisson ratios	Experimental Values	
Extensional E_z	37.759	GN/m ²
Extensional E_x	8.785	GN/m ²
Poisson ν_{xy}	0.354	
Poisson ν_{xz}	0.319	
Poisson ν_{zx}	0.074	
Shear G_{xy}	3.243	GN/m ²
Shear G_{xz}	4.422	GN/m ²

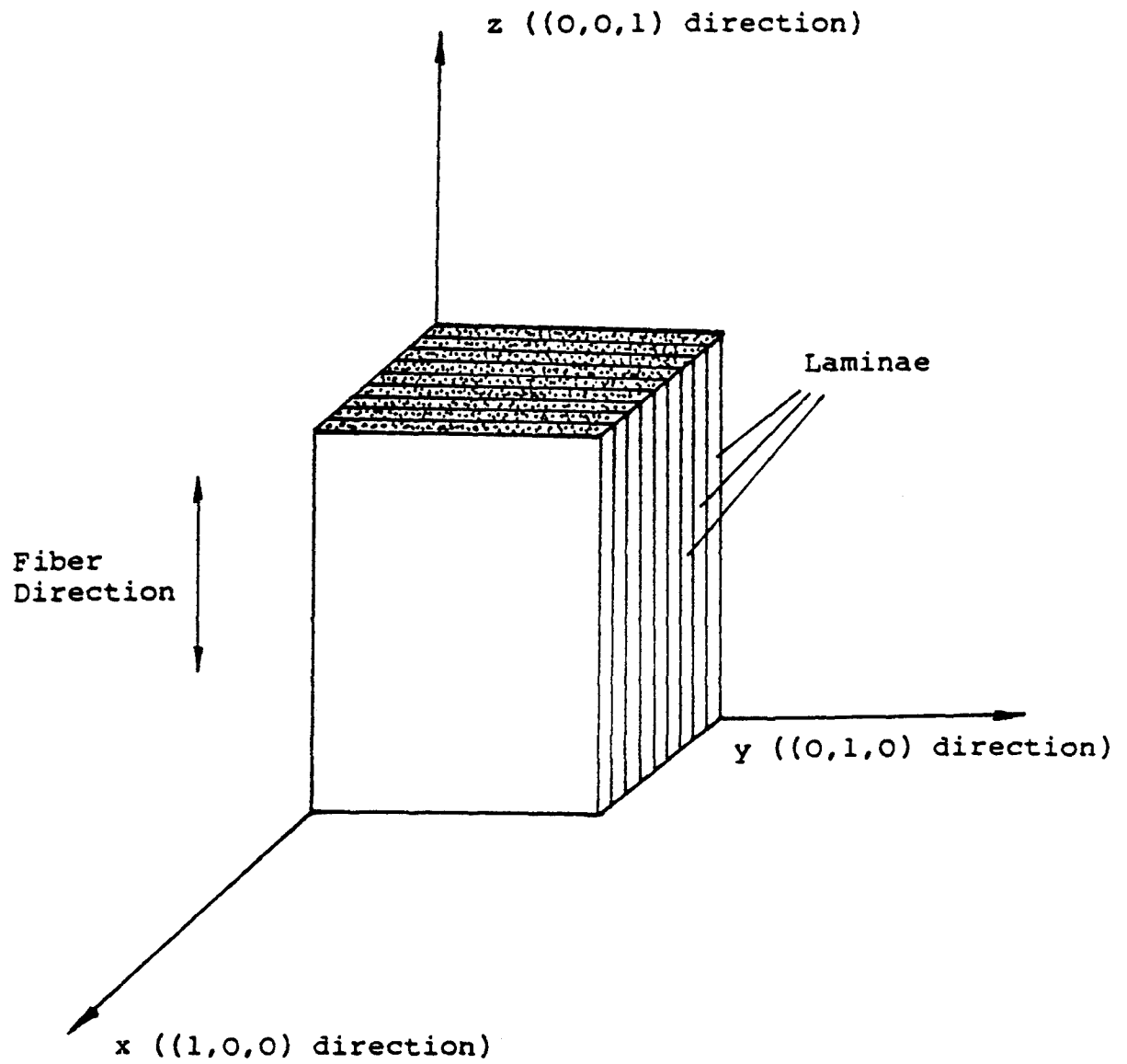

Fig.1 Laminate fiberglass epoxy composite showing principal directions.

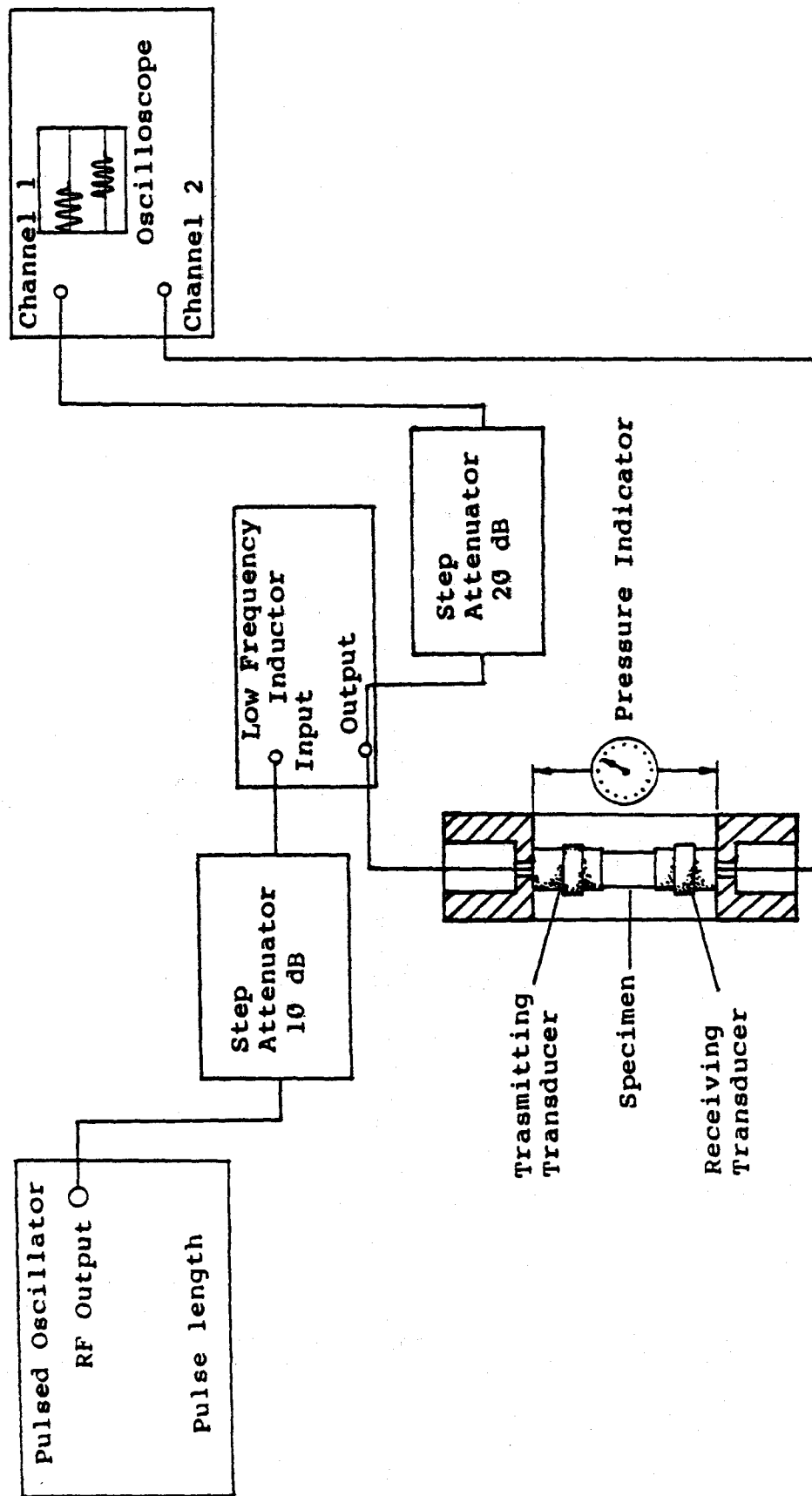

Fig.2 Schematic of experimental system for through transmission measurements.

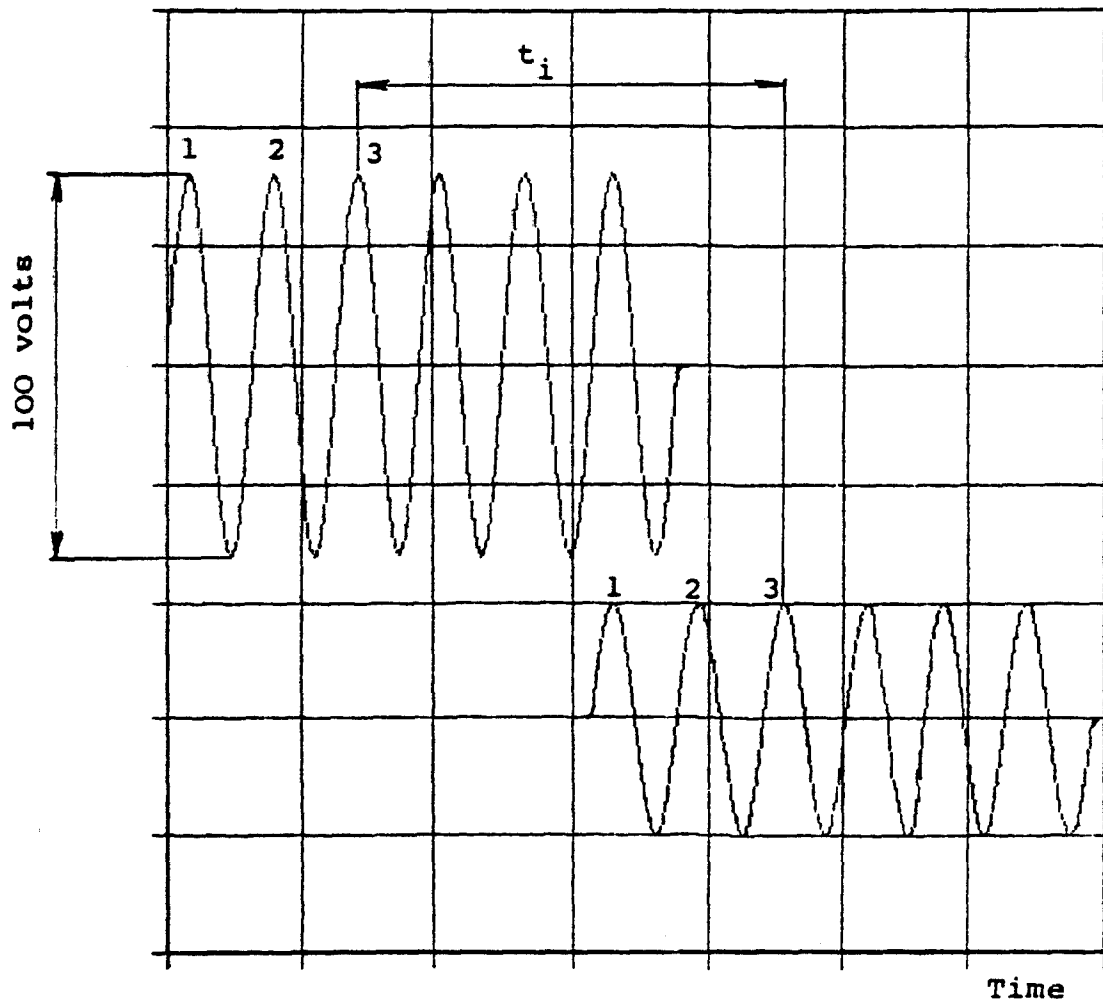

Fig.3 Typical input (upper) and output (lower) signals in through transmission measurements showing reading of time t_i using the third positive peak of each signal.

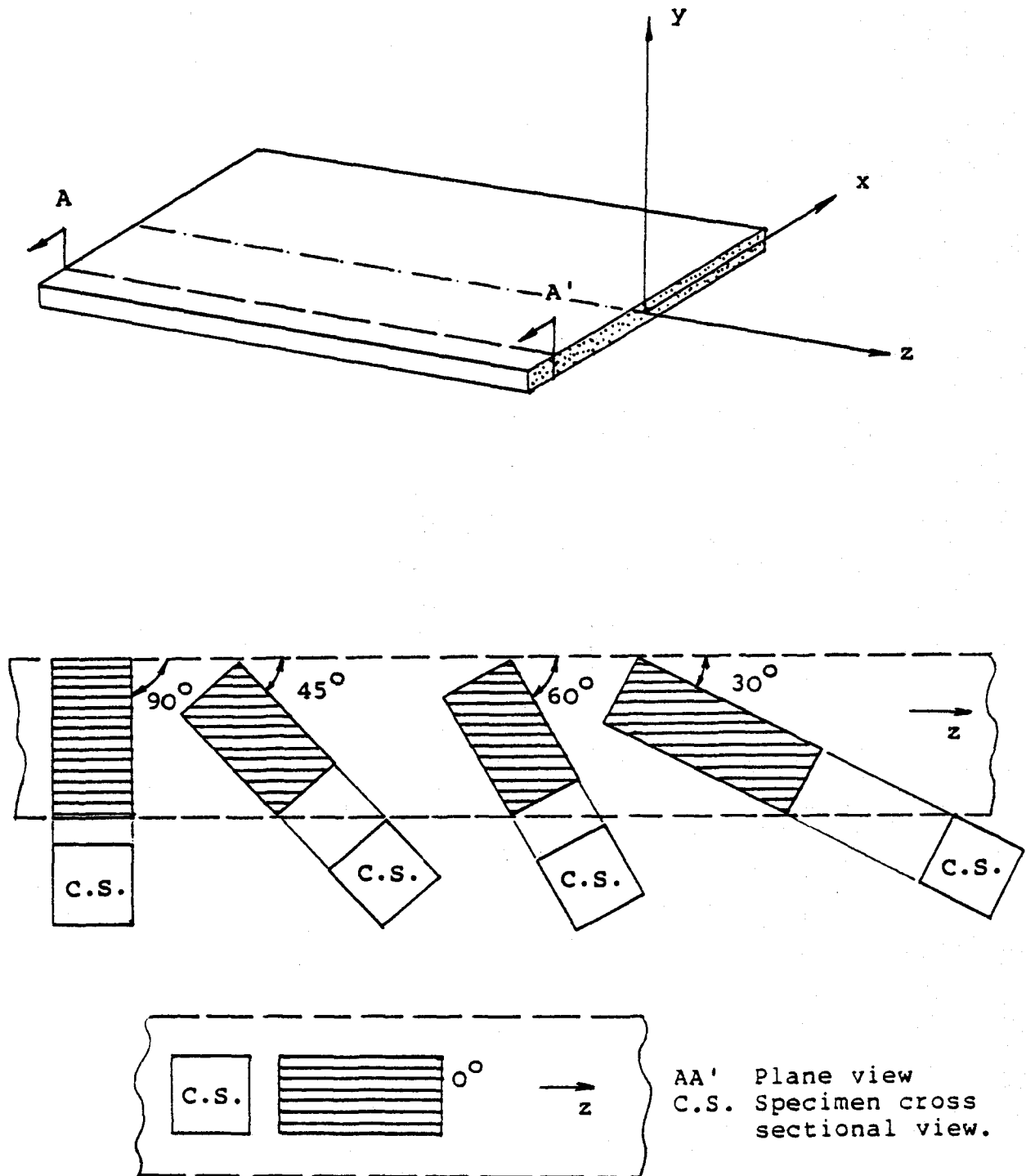

Fig.4 Position of specimens with respect to longitudinal axis (z) of original plate.

1. Report No. NASA CR-4034		2. Government Accession No.		3. Recipient's Catalog No.	
4. Title and Subtitle Ultrasonic Determination of the Elastic Constants of the Stiffness Matrix for Unidirectional Fiberglass Epoxy Composites				5. Report Date December 1986	
				6. Performing Organization Code	
7. Author(s) Elizabeth R. C. Marques and James H. Williams, Jr.				8. Performing Organization Report No. None (E-3271)	
				10. Work Unit No. 506-43-11	
9. Performing Organization Name and Address Massachusetts Institute of Technology Department of Mechanical Engineering Cambridge, Massachusetts 02139				11. Contract or Grant No. NAG3-328	
				13. Type of Report and Period Covered Contractor Report Final	
12. Sponsoring Agency Name and Address National Aeronautics and Space Administration Lewis Research Center Cleveland, Ohio 44135				14. Sponsoring Agency Code	
15. Supplementary Notes Project Manager, Harold E. Kautz, Structures Division, NASA Lewis Research Center.					
16. Abstract The elastic constants of a fiberglass epoxy unidirectional composite are determined by measuring the phase velocities of longitudinal and shear stress waves via the through transmission ultrasonic technique. The waves introduced into the composite specimens were generated by piezoceramic transducers. Geometric lengths and the times required to travel those lengths were used to calculate the phase velocities. The model of the transversely isotropic medium was adopted to relate the velocities and elastic constants.					
17. Key Words (Suggested by Author(s)) Nondestructive testing; Nondestructive evaluation; Ultrasonics; Phase velocity; Elastic moduli; Fiber composites; Fiber fraction			18. Distribution Statement Unclassified - unlimited STAR Category 38		
19. Security Classif. (of this report) Unclassified		20. Security Classif. (of this page) Unclassified		21. No. of pages 26	22. Price* A03

*For sale by the National Technical Information Service, Springfield, Virginia 22161