



NAVAL FACILITIES ENGINEERING SERVICE CENTER
Port Hueneme, California 93043-4328

Technical Report TR-2049-SHR

SHORE-TO-SHIP STEAM PURIFICATION INVERSE FLASH STEAM PURIFIER (IFSTEP) FIELD UNIT TESTS

by

G. Murphy, S. Maga, and M. Silbernagel

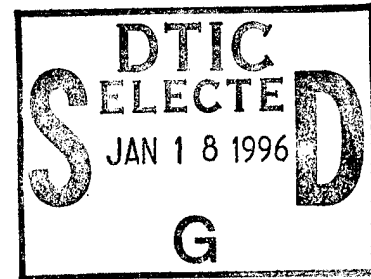

October 1995

19960116 007

Sponsored by
Office of Naval Research

FOR QUALITY INSPECTED 1

REPORT DOCUMENTATION PAGE

Form Approved
OMB No. 0704-018

Public reporting burden for this collection of information is estimated to average 1 hour per response, including the time for reviewing instructions, searching existing data sources, gathering and maintaining the data needed, and completing and reviewing the collection of information. Send comments regarding this burden estimate or any other aspect of this collection information, including suggestions for reducing this burden, to Washington Headquarters Services, Directorate for Information and Reports, 1215 Jefferson Davis Highway, Suite 1204, Arlington, VA 22202-4302, and to the Office of Management and Budget, Paperwork Reduction Project (0704-0188), Washington, DC 20503.

1. AGENCY USE ONLY (Leave blank)		2. REPORT DATE October 1995		3. REPORT TYPE AND DATES COVERED Not final; FY93 through FY95	
4. TITLE AND SUBTITLE SHORE-TO-SHIP STEAM PURIFICATION INVERSE FLASH STEAM PURIFIER (IFSTEP) FIELD UNIT TESTS				5. FUNDING NUMBERS	
6. AUTHOR(S) G. Murphy, S. Maga, and M. Silbernagel					
7. PERFORMING ORGANIZATION NAME(S) AND ADDRESS(ES) Naval Facilities Engineering Service Center 560 Center Drive Port Hueneme, CA 93043-4328				8. PERFORMING ORGANIZATION REPORT NUMBER TR-2049-SHR	
9. SPONSORING/MONITORING AGENCY NAME(S) AND ADDRESSES Office of Naval Research Arlington, VA 22217-5000				10. SPONSORING/MONITORING AGENCY REPORT NUMBER	
11. SUPPLEMENTARY NOTES					
12a. DISTRIBUTION/AVAILABILITY STATEMENT Approved for public release; distribution unlimited.				12b. DISTRIBUTION CODE	
13. ABSTRACT (Maximum 200 words) The Inverse Flash Steam Purifier (IFSTEP), a device to remove noncondensable gases from steam, was developed, tested, and evaluated. IFSTEP provides an alternative to methods that generate pure steam. Steam can now be purified at selected points in the steam distribution line, thus improving steam for facilities where required. This differs from reverse osmosis, de-mineralization, and de-alkalization that necessarily purify all the steam, as they are feed water treatment methods. With IFSTEP, simple water softening is adequate. The expense of the comprehensive feed water treatment, hazardous material handling, and labor intensive operation is diminished. Test data illustrate the behavior of IFSTEP during early bench tests and current field tests. Under a wide variety of upstream pressure and downstream steam demands, including boiler shutoff and startup conditions, IFSTEP consistently provided clean steam. The best results were achieved with a pressure difference control valve, which maintained a constant pressure or temperature difference between the shell and tube side of the heat exchanger. A prototype design is presented that reflects the improvements suggested by all previous testing. The prototype is modular to allow capacity growth and to meet most activity requirements.					
14. SUBJECT TERMS IFSTEP, steam, water softening, shore-to-ship steam purification				15. NUMBER OF PAGES 48	
				16. PRICE CODE	
17. SECURITY CLASSIFICATION OF REPORT Unclassified		18. SECURITY CLASSIFICATION OF THIS PAGE Unclassified		19. SECURITY CLASSIFICATION OF ABSTRACT Unclassified	
				UL	

CONTENTS

	Page
INTRODUCTION	1
BACKGROUND	1
Water Treatment	2
IFSTEP	2
IFSTEP CONFIGURATION	3
Heat Exchanger	3
Separator	4
Control Valve	4
Field Units	4
IFSTEP PERFORMANCE	5
Boundary Conditions	5
Steam Purity	6
Thermodynamic Quality	6
Capacity	7
Internal IFSTEP Properties	7
Startup Operations	8
Heat Exchanger Effectiveness	8
Reliability, Availability, and Maintainability	9
Costs	9
PROTOTYPE DESIGN	10
Configuration	10
Predicted Capacity	11
Predicted Costs	11
CONCLUSIONS.....	11
IFSTEP Early Configuration	12
Boundary Conditions	12
NSTM Steam	12
IFSTEP Performance	12

	Page
Reliability, Availability, Maintainability	13
Costs	13
Prototype Design	14
RECOMMENDATIONS	14
REFERENCES	15

Accession For	
NTIS CRA&I	<input checked="" type="checkbox"/>
DTIC TAB	<input type="checkbox"/>
Unannounced	<input type="checkbox"/>
Justification	
By	
Distribution /	
Availability Codes	
Dist	Avail and/or Special
A-1	

INTRODUCTION

The Inverse Flash Steam Purifier (IFSTEP) field units were tested and evaluated at a variety of field conditions. The IFSTEP units were assessed relative to their ability to purify steam and maintain Naval Ship Technical Manual (NSTM) Standards (Ref 1) on shore-to-ship production steam. This report also presents the prototype design requirements, expected performance, and costs.

IFSTEP steam purification differs from current technology that necessarily purifies boiler feed water to produce pure steam. IFSTEP purifies steam either at the steam plant or at selected points in the steam distribution system, where it is specifically required. NSTM quality steam can be generated using sodium zeolite ion exchangers (water softeners), eliminating the need for reverse osmosis (RO)/de-mineralization and de-alkalization treatment.

The IFSTEP field units were designed to accommodate the shore-to-ship steam capacity at the shore boiler plant located at the Naval Construction Battalion Center (NCBC), Port Hueneme, California, and the tidal area of the Naval Weapons Station (NAVWEAPSTA), Concord, California. The NCBC system was sized to provide for the dedicated needs of the port having an estimated 1,000 lbm/hr demand, which is a 10/1 flow rate upscale version of the first IFSTEP system. The NAVWEAPSTA Concord IFSTEP, termed the NWS unit, was sized for a capacity of 10,000 lbm/hr, representing a near 100/1 flow upscale of the early version. The NWS unit reflects a more modular aspect using symmetry and manifolds. A D-PRV was found superior to the orifice and pressure reducing valve, as the pressure difference (i.e., temperature difference) between the tube and shell side of the heat exchanger is maintained under all flow conditions.

A summary of the test and evaluation effort is presented with emphasis on the NCBC and the NAVWEAPSTA Concord field units. More than 2,000 operational hours were experienced at field conditions. IFSTEP performance is compared with the various upscale units relative to boundary conditions, water treatments, boiler and pier steam purity, thermodynamic quality, unit capacity, and startup operations. The evolution of performance has led to the described optimal configuration of a prototype system, soon to be tried in the field.

This effort is a requirement established in the Shore-to-Ship Steam Purification Project Management Plan, approved and funded by the Office of Naval Research and overseen by the Naval Facilities Engineering Command.

BACKGROUND

There are 34 home ports (40 worldwide) that provide utility service to the Fleet. For steam alone more than 3.5 million million (10^{12}) BTUs of energy are needed annually by the ships in port.

Most activities have more than one boiler plant, each with more than one boiler, that provide steam to both the base and ships. There are also dedicated plants that provide steam to only berthed ships. The boilers are generally package boilers that provide steam from 150 to 450 psig at flow rates ranging from 1,000 lbm/hr to 150,000 lbm/hr.

Water Treatment

In the past, boiler feed water was treated using sodium zeolite ion exchangers. Now, in order to generate NSTM criteria steam, reverse osmosis/de-mineralization and de-alkalization feed water treatment are the alternatives examined.

The use of sodium zeolite ion exchangers permits bicarbonates to enter the boiler. Due to the heat and pressure in the boiler, the bicarbonates decompose to release carbon dioxide into the steam. This results in a steam quality where the pH is near 4.5 to 5 and a conductivity that is generally higher than 10 $\mu\text{mho/cm}$. When amines are added, the steam pH rises as does the conductivity. Eventually, the conductivity rises above 25 $\mu\text{mho/cm}$ even before reaching a pH of 7, as exemplified in Figure 1a. Note that the pH-conductivity profile is far removed from the desired NSTM zone.

Currently, a variety of boiler water treatments are available to generate NSTM steam. Typically, reverse osmosis/de-mineralization or de-alkalization are employed, depending upon the municipal water quality. The reverse osmosis/de-mineralization results in steam having a near neutral pH and a conductivity of less than 2 $\mu\text{mho/cm}$. When amines are added, the steam pH easily rises to 8 to 9.5 with a conductivity substantially less than 25 $\mu\text{mho/cm}$.

De-alkalization, under some cases, can also generate NSTM steam. For example, it produces a boiler steam pH usually near 5.5 with a conductivity of less than 2 $\mu\text{mho/cm}$. When amines are added, the criteria are met (Figure 1b). As may be observed in the figure, the steam quality depends on the alkalinity level of the boiler feed (i.e., downstream of the de-alkalizer). When the de-alkalizers approach a saturated state, the alkalinity rises to the point that NSTM steam is no longer produced. Ultimately, the de-alkalizers act as water softeners, as shown in Figure 1b (see alkalinity of 41 ppm). De-alkalization, as well as reverse osmosis/de-mineralization, is relatively labor intensive, expensive to maintain and operate, and unlike water softeners requires handling hazardous material.

IFSTEP

With the large quantity of steam production Navy-wide, even small improvements can result in significant annual savings. The high cost of generating NSTM steam alerted the Office of the Chief of Naval Research (OCNR) and the Naval Facilities Engineering Command (NAVFAC) to explore other means of producing high quality shore-to-ship steam. An Independent Research (IR) and Exploratory Development (IED) Program was initiated and IFSTEP evolved (Refs 2, 3, and 4). A recent and thorough economic analysis (Ref 5) revealed the IFSTEP concept as cost effective and applicable for other Navy and civilian uses as well.

The current IFSTEP design stems from the early investigations and the ensuing verification and optimization tests (Refs 6 and 7). The NCBC and the NAVWEAPSTA Concord unit tests (Refs 8 and 9) quantified performance with field conditions.

The concept of IFSTEP is portrayed in Figure 2. Impure (feed) steam enters the unit and collects in the tube side where it is partially condensed. The liquid collects in a separator reservoir as a pure condensate, passes through a constriction or valve, and then evaporates in the shell side of the regenerator or heat exchanger. Excess feed steam exits as byproduct steam. The basic system has no moving parts, and eliminates nearly all noncondensable gases, particularly those causing low pH steam. The system works by virtue of the pressure difference across the constriction, which effectively reduces the liquid temperature, allowing condensation to take place on the tube side of the heat exchanger and evaporation to take place on the shell side.

When using IFSTEP to generate steam, the feed water treatment is sodium ion exchanging or water softening. Even though the boiler export steam pH is near 4.5 to 5 and conductivity near 10 $\mu\text{mho/cm}$ (Figure 1a), when entering IFSTEP, the steam is processed to a product approaching a neutral pH and a conductivity less than 2 $\mu\text{mho/cm}$ (Figure 1c). The performance is independent of the condition of the feed water treatment. When amines are added to the product steam, like with de-mineralization treatment, NSTM criteria are easily met (Figure 1c). Note, the theoretical amount of noncondensable gas, carbon dioxide, in the product steam is 1 ppm. All the data in Figure 1 were acquired from the field and represent actual conditions encountered.

IFSTEP CONFIGURATION

The basic elements of the IFSTEP configuration are shown in Figure 2. This configuration is comprised of the heat exchanger, separator, and flow restrictor. Each major component offers a number of types and sizes to consider. These component variations were assessed, and candidates tested and evaluated at different boundary conditions. The early tests and eventual field unit installations lead to the prototype design.

The first IFSTEP unit (Ref 2) is represented by the concept in Figure 2 and is depicted in Figure 3. The heat exchanger is vertical. The tube side is single pass, for unrestricted flow, where condensation takes place. The single pass shell side permits pool formation and is where pool boiling occurs. The shell side flow is counter to the tube side flow to increase effectiveness. The separator collects the condensate and seals out any noncondensable gas. The flow resistor is a hand-operated throttling valve. These basic components proved the concept of IFSTEP.

Heat Exchanger

Validation and optimization tests helped define specific component configurations. The actual bench test setup is shown in Figure 4 where a horizontal heat exchanger was installed. The different heat exchangers, orientations, and number of passes examined are summarized in Figure 5. The system performance was found to improve as the heat exchanger length increased (Figures 5a and 6a). The vertical orientation (Figure 5b) is best (Figure 6b), although the incline yielded nearly equal results. The number of tube side passes (Figure 5c) seemed to improve

performance (Figure 6c), but this was restricted to horizontal heat exchangers, having a lesser performance than the vertical.

Separator

The off-the-shelf steam separator (Figure 7a) was found to limit the capacity of IFSTEP. This was attributed to the reentrainment of liquid in the reservoir and conveying the liquid out with the byproduct stream. The separator was replaced with an off-the-shelf tank (termed reservoir, accumulator, or surge tank) and a flow redirector, indicated by the dotted line in Figure 7b. A bleed line was added to ensure that noncondensable gas accumulation was minimal (Figure 7c). Should noncondensable gases build, the subsequent rise in partial pressure would increase the solubility of the gas in the liquid, increasing conductivity and dropping pH. IFSTEP performance improved slightly less than 10 percent (Figure 6d) by using the reservoir, bypass, and bleed instead of the separator.

Control Valve

An orifice or a hand-operated control valve works well for relatively constant flow rates. However, when the flow rate or steam demand varies (e.g., drops in half), the pressure difference lessens (e.g., falls by 3/4). There is a corresponding inadequate temperature difference across the heat exchanger, causing liquid to void the storage (surge) tank (Figure 8a).

Using a pressure regulating valve (PRV) is appropriate as long as the flow is relatively constant. Should the flow drop, a prescribed temperature difference could not be maintained, similar to the fixed valve.

A differential pressure regulating valve (D-PRV) is ideal and recommended. The pressure or temperature difference can always be maintained regardless of the flow rate or upstream or downstream pressure (Figure 8b). Note the steady full liquid level and the unchanging pressure difference.

Field Units

The IFSTEP field units are products of the findings of the earlier validation and optimization testing. Each unit is improved as it is upscaled, including any corrective changes that enhance performance under the field boundary conditions.

NCBC Field Unit. The IFSTEP system was sized to meet the steam demands estimated by Port Services at NCBC and the Military Handbook for Dockside Utilities (Ref 10). A flow rate of just over 1,000 lbm/hr was estimated, but the unit was designed for over 2,000 lbm/hr to ensure total flow production. The physical features of the NCBC unit are most easily perceived by the schematic in Figure 9. There are two heat exchangers in parallel. This reduces the size of the heat exchangers required and provides an element of redundancy, should one heat exchanger fail. If one does fail, the entire system need not be secured. The failed heat exchanger is valved out, removed, and replaced.

The heat exchangers represent a 26/1 heating area scale, versus the 10/1 flow rate scaling of the earlier IR unit (heating area is $2.53 \text{ ft}^2 = \text{scale } 1$). Globe valves were installed upstream of

each unit on the tube side and the shell side. These were added should it be necessary to balance the flow rates through heat exchangers, a consideration of balancing units that are in parallel. No adjustment was made in the tests.

A steam separator was added upstream of the unit to eliminate total suspended solids (TSS) within the flow stream. This was a request by NAVFAC to determine IFSTEP's influence on TSS. It was inconclusive that the separator could remove the contaminant to the 0.1-ppm TSS level.

The field system was fully instrumented to continuously measure pressures, temperatures, flow rates, thermodynamic quality, and steam purity (Figure 10). These properties were obtained for the feed, byproduct, and product streams. In addition, internal temperatures and pressures were measured at the heat exchanger tube side exit, shell side inlet, and within the surge tank.

The NCBC IFSTEP field unit is pictured in Figure 11. The system is 6 feet wide, 4-1/2 feet deep, and 6-1/2 feet high. It weighs approximately 1,400 lbf. There are no electrical, cooling water, or waste needs, other than the steam trap for the separator. An amine injection system is not considered part of IFSTEP as all boiler plants now require them to increase the pH from a near neutral value to 8 to 9.5. However, it was portrayed in the instrumentation diagram, due to steam analysis conducted downstream.

NAVWEAPSTA Concord Unit. The physical features are not unlike those shown in the schematic of the NCBC unit (Figure 9). The system was sized by heat exchanger area scaling (135/1) and isokinetic similitude (Table 1), where pipe flow velocities are maintained. Again, there are two vertical heat exchangers in parallel. All manifolds, however, are common. This allows the addition of heat exchangers by simply extending the common manifolds. Manifolds exist for heat exchanger inlets and exits on both the tube and shell side. The unit was fully instrumented in the same manner as the NCBC field unit (Figure 10).

The NWS IFSTEP field unit is pictured in Figure 12, on location in Building 407 at NAVWEAPSTA Concord. The system is 8-1/2 feet long, 5 feet wide, and 7-2/3 feet high. It weighs approximately 7,000 lbf. Electrical was required for instrumentation and the electronic control valve. Cooling water for the sample coolers and waste for the separator steam trap were the only supporting utility requirements. An amine injection system was already in place at the site.

IFSTEP PERFORMANCE

All the results presented are typical and indicate only a short duration of the time monitored. More than 2,000 hours of operation were logged and analyzed in the NCBC tests (Ref 8) and the NAVWEAPSTA Concord tests (Ref 9) alone. The transient performance data were recorded minute by minute, night and day. All data are stored on magnetic and optical disks, and thus, retrievable.

Boundary Conditions

The boundary conditions are those imposed upon IFSTEP by external operations. For example, the boiler pressure is a source condition and the steam demand is a sink or user

condition, both of which IFSTEP does not control. IFSTEP is thus judged by its performance or adaptability in providing quality steam under a variety of boundary conditions. Severe conditions, such as unplanned boiler shutdowns, were encountered in the field testing, and became a means to evaluate IFSTEP behavior.

The boiler pressure can be highly cyclic with wide excursion (20 percent) in magnitude, exemplified by Figures 13a and 13b, for the bench and NCBC field units. The boiler pressure may also be relatively steady (Figure 13c), as experienced by the NWS system. IFSTEP units encountered a steady state component of pressure varying from 100 to 200 psig.

The steam demand is a downstream condition imposed on the IFSTEP unit. This too can be quite varied, as suggested by extreme step changes in the bench tests (Figure 13a), as well as the simulated excursions (Figure 13b) and actual ship (Figure 13c) steam demands.

Steam Purity

The production of NSTM steam is most easily visualized by a pH/conductivity map. The map shows an immediate, global assessment of performance (Figure 14a). The desired NSTM zone is portrayed as the enclosed box representing the permissible limits of pH (8 to 9.5) and of conductivity (less than 25 $\mu\text{mho/cm}$).

The IR/IED and later optimization bench tests validated the IFSTEP concept (Figure 14a). The impure feed steam, steam upstream of IFSTEP, was generated from boilers with water softeners. The resulting pH was between 4.5 and 5.5 and the conductivity ranged from 10 to 35 $\mu\text{mho/cm}$, well outside the NSTM criteria zone. The IFSTEP product steam was within the zone. This illustrated that pure steam can be extracted from impure steam, using mechanical means.

Typical purification performance for the field units is shown in Figures 14b and 14c. The impure feed steam has a pH near 4.2 and conductivity varying from 7 to 15 $\mu\text{mho/cm}$. Within IFSTEP, the noncondensable gas separation process increases the pH and reduces the conductivity. In the NCBC unit, the increased pH varies from 6.5 to 7.5, and a decreased conductivity is steady near 7.5 $\mu\text{mho/cm}$. The NWS Concord unit yields a processed pH ranging from 4.5 to 6, but at a low conductivity of 2 $\mu\text{mho/cm}$. For both field units, the IFSTEP product steam centers in the NSTM zone. Like de-alkalizers and RO/de-mineralization systems, amines are added to meet the NSTM Standards. For IFSTEP processing, amines added are typically less than 3 ppm. In one case, no amine addition was necessary to obtain NSTM level steam (Ref 7).

Thermodynamic Quality

The thermodynamic quality of steam is a measure of dryness. A 97 percent quality (3 percent wetness) means that 97 percent of the steam is saturated vapor and 3 percent is a saturated liquid, or 3 percent of the steam, by mass, is dispersed liquid droplets. The droplets have little heating value. A typical steam distribution system has 97 percent quality steam.

The IFSTEP product steam quality encountered in all the tests (bench or field) was above 99.5 percent (Figure 15). The byproduct steam had similarly high values.

Capacity

The capacity of IFSTEP is controlled by the surface area of the heat exchanger, the pressure or temperature difference between the tube and shell side of the heat exchanger (i.e., across control valve), and the byproduct flow rate. The maximum capacity achieved over a range of control valve (CV) pressure differences is revealed in Figure 16, for the bench, NCBC, and NWS systems. In general, the capacities were obtained when the byproduct flow was less than 12.5 percent of the feed flow, and sometimes lower than 5 percent.

Establishing the maximum performance at a specified pressure difference is determined by encouraging an increase in steam demand until liquid depletes in the surge tank reservoir or when the product thermodynamic quality begins to diminish. In addition, the minimum byproduct flow is recognized when the surge tank steam purity begins to degrade by the buildup of noncondensable gases. These methods are detailed in the test reports (Refs 8 and 9).

For the NWS Concord installation, a single boiler was adequate for meeting the needs of a ship. With a single ship drawing steam, the flow was typically less than 4,000 lbm/hr (Figure 13c), the system could suitably operate with a control valve pressure difference of 35 psid for one heat exchanger operational or 18 psid for two (Figure 16c). With two heat exchangers, a control valve setting of 40 psid yielded a maximum system flow of 9,200 lbm/hr, suitable for all the conditions encountered.

Internal IFSTEP Properties

The behavior of IFSTEP to the boundary conditions was observable due to the fully instrumented unit. The external excitation of boiler pressure and ship steam demand conditions, depicted in Figure 17a, are typical.

Byproduct Flow, Liquid Level, and Control Valve. Steady, internal system behavior is experienced during dynamic excursions (Figure 17b). The byproduct flow is steady, near a low 280 lbm/hr (Figure 17a). The surge tank, which provides the liquid seal and reservoir for infrequent highly unsteady conditions, has a maximum liquid level (100 percent full) over the duration (Figure 17b). The control valve pressure difference is steady at 40 psid in spite of the boundary condition movement.

Pressures and Temperatures. The pressures upstream and downstream on the tube and shell side of the heat exchangers and the byproduct pressure are shown in Figure 18a. The pressure difference of 40 psid shown is the result of the control valve. Other point-to-point pressure variations are small, generally less than several psid, suggesting minimal losses.

The temperature locations are also upstream and downstream of the heat exchangers on the tube and shell side. The temperature variation between the tube (feed) and the regen (shell inlet) reflects the control valve action of maintaining a 40 psid, or a 22.5°F difference in temperature (Figure 18b). This corresponds to a change in saturation states. The product temperature is just 10 degrees shy of the feed steam, indicating superheated conditions. This high thermodynamic quality condition is verified when noting the product and byproduct

throttling calorimeter temperatures. The high temperatures indicate high quality conditions of greater than 99.5 percent.

Startup Operations

The dry startup condition can occur as a planned or unplanned event. It is a worst-case scenario, requiring liquid to form in the surge tank and prevent noncondensable gases from entering the product line. The planned event would be a self-imposed condition to simplify first-time startup, minimizing potential cavitation or water hammer. The unplanned case would only occur if the entire reservoir evacuated, which has never occurred.

A dry startup operation was induced at NWS Concord. Liquid began to form in the surge tank almost immediately (Figure 19a). It takes only about 5 minutes (Figure 19b) to begin producing NSTM steam again.

A steady improvement in time was experienced over the development of IFSTEP. Bench, validation, and NCBC test startups changed from 24 to 8 minutes (Refs 7, 8, and 9).

Heat Exchanger Effectiveness

The evolution of the IFSTEP design follows the initial IR/IED vertically oriented, single pass heat exchanger, with condensing on the tube side, and shell side evaporation counter current to the tube flow. It was subsequently found that the vertical heat exchanger performance diminished with size increases. The performance of the different IFSTEP units was compared using a flow rate heat flux parameter, which is defined as the maximum product flow achieved for a given tube heating area (lbm/hr/ft²). The parameter would be expected to yield a relatively constant value as the heat exchanger size increases, all other fluid properties being equal. A constant flow rate heat flux did not occur.

Vertical Orientation. The flow rate heat flux (flow rate/heating area) for the vertical heat exchangers is related to the temperature difference between the tube and shell side of the heat exchanger or across the control valve as shown in Figure 20. Note the steady drop in flow rate heat flux curves as the scale increases (heating area scale of 1 equals 2.53 ft² of the IR/IED unit).

The flow rate heat flux can be related to the scaling parameter. At a specified temperature difference of 22.5°F (~40 psid), the curve emphasizes the flux drop (Figure 20b). Where the IR/IED unit possesses a flow rate heat flux value of 35, the NWS unit experiences a value of 13. This suggests an efficiency loss for the higher capacity heat exchangers, which was not revealed in the optimization tests (Figure 6a). In the field versions, the diameter of the heat exchanger necessarily grew to increase the surface area, while constraining the length. Longer heat exchanger lengths for vertical orientations were compromising system assembly, transportation, operation, and costs. Costs would substantially increase as the diameter of the heat exchanger barrel increases. Moreover, fixed tube sheets, where tubes are attached to a plate, were found unacceptable because of induced thermal stresses, and the floating sheets needed to overcome the stresses were formidable in cost.

These problems were resolved by revisiting the horizontal heat exchanger. The U-tube heat exchanger was preferred, as it has only one tube sheet, allowing unlimited expansion. The U-tube is also less expensive than two tube sheet systems.

Horizontal Orientation. The earlier tests on horizontal heat exchanger orientation (Figures 5b and 6b) revealed a low capacity system subject to internal flow oscillations. It was found that these flow oscillations could be avoided by increasing system internal resistance and by operating at more desirable controlled conditions, which was achieved by the D-PRV. A variety of heat exchanger features were tested, such as type, passes, tube port position, shell port positions, baffle spacing, and baffle orientation (Figure 21). The tests revealed (Ref 11) that U-tube heat exchangers outperformed the conventional or fixed tube sheet heat exchangers (Figure 22a). Shell side condensing was preferred over tube side condensing (Figure 22b). As the number of passes increased, the performance generally increased. The tighter the baffle spacing the better (Figure 22c), but this was limited by the increase in flow resistance.

The resulting flow rate heat flux for the U-tube heat exchanger having four passes and shell side condensing was 46 lbm/hr/ft/ft (Figure 20b). This was far greater than the vertical conventional units, the highest being the IR/IED system of 35 lbm/hr/ft/ft. With the vertical heat exchangers, a factor of 2 reduction in flow rate heat flux was experienced between the scale of 10 and 135 (Figure 20b). Should this factor of 2 be encountered with the horizontal heat exchangers, the flow rate heat flux will still be twice that of the vertical heat exchanger. A more efficient system results.

Reliability, Availability, and Maintainability

The field units have experienced a total of nearly 2,000 hours of operation. With the NCBC unit, the mechanical PRV used for flow control tended to leak. This type of valve is no longer used (Ref 8). One of the heat exchangers also leaked after 1,000 hours. No system downtime was experienced, since the remaining heat exchanger was functional, and there was an additional heat exchanger in inventory. The failure was attributed to startup thermal stresses, compromising the commercial quality heat exchanger with the fixed tube sheets.

The NWS unit consists of industrial grade heat exchangers, built to Tubular Exchange Manufacturer's Association (TEMA) standards, having a floating tube sheet to overcome potential thermal stress problems. No heat exchanger leaks were experienced with these heat exchangers during the 1,000-hour test period. Leaks did occur with the 2-inch, three-piece ball valves (Ref 9). These were judged unacceptable. All valves will now be either globe or gate.

Costs

The largest contributor to the overall IFSTEP cost is the heat exchanger (Table 2). Experience with acquiring the vertical heat exchanger showed a nearly 30 percent cost increase from the commercial grade with fixed tube sheets (\$13k) to an industrial grade (TEMA Class) floating tube sheet (\$16.6k). The next item is the valves (\$11.3k), followed by the separator (\$2.8k) and the surge tank (\$2k). With the fabrication and assembly, the total cost climbs to \$84.8k. This is slightly less than the cost estimated in the economic analysis report of \$91k (Ref 5). Horizontal heat exchangers would decrease the actual cost from \$84.8k to 68.6k. The nearly

20 percent reduction in cost makes the economic analysis of IFSTEP more favorable by reducing the payback period. The payback period varied between 1.6 and 6 years, depending upon the activity.

PROTOTYPE DESIGN

With the experience acquired from the field testing and the horizontal heat exchanger tests, an optimal design unfolds. While the components do not change, the flow stream, orientations, and component types do. Thus, a more efficient system evolves. The system is modular, with each unit being identical except for the control subsystem.

Configuration

The basic prototype IFSTEP system is modular in nature, as depicted by the end view in Figure 23 which shows a primary assembly and an auxiliary assembly. The side view is shown in Figure 24. There can be more than one auxiliary module operating off the primary unit. Each module contains two U-type heat exchangers (344 ft² heating area, four tube pass, segmented vertical baffles) positioned above a surge tank reservoir.

Feed flow enters the shell side of the heat exchangers from the rear of the unit. A feed manifold directs steam flow upward through risers to the bottom aft end of the heat exchanger barrel. The flow stream partially condenses and exits the forward end of the heat exchanger at the bottom of the barrel (Figure 24). The two-phase fluid flows aftward and pours into the surge tank (reservoir). The vapor (excess feed) in the tank flows out the bleed at the back of the tank and into a byproduct header (Figure 24). Note that the design incorporates the byproduct flow and bleed flow function into a single stream, eliminating the liquid entrainment and reservoir depletion of previous designs. The liquid in the tank flows through the D-PRV and into the heat exchanger head at the bottom of the tube side channel. The flow then traverses the tubes, vaporizes, and exits the head to risers that tee into a common product manifold above the heat exchangers.

The surge tank incorporates several unique features (Figure 25). A surface slosh and impingement baffle, of cellular design, is placed near the top of the tank. This disperses the incoming two-phase flow and dampens any sympathetic or externally-induced oscillations of flow. A simple antiswirl crosswise exit baffle at the bottom of the tank minimizes premature liquid dropout caused by gravity-induced Coriolis circulation.

Each IFSTEP module is identical except for the primary assembly that has the control valve. The manifolds run the width of the modules. Modules are connected by spool pieces. Feed flow, product flow, and byproduct flow may enter or exit from either side of the modules. Auxiliary modules may be positioned on either side of the primary module.

Each module will weigh approximately 7,000 lbf, so it can be forklifted. The dimensions are 4.3 feet wide by 5.5 feet high by 10 feet long. The unit is a foot shorter in width, 2 feet shorter in height, and 1.5 feet longer than the NWS IFSTEP unit. Maintenance is expected to be simpler due to the lower height and component accessibility. Note that there is easy access to the tubes for their removal or replacement (Figure 24).

Predicted Capacity

Module. While the prototype unit is soon to be tested, its capacity may be estimated by the small scale (10/1) tests. It is expected that the flow will at least be equivalent to the field size vertical unit tested at NAVWEAPSTA Concord. Should this be the case, the flow of a single module would be near 10,000 lbm/hr. As the flow rates of the horizontal heat exchangers were twice that of the vertical heat exchangers in the scale tests, then the flow of the prototype could be as high as 20,000 lbm/hr per module. Establishing the actual flow will control how many modules are required for the different shore boiler plants.

Navy-Wide. The total number of activities that can be treated by IFSTEP is summarized in Figure 26a. For example, a 10,000-lbm/hr capacity unit can reasonably treat 75 percent of the existing activities, but the number of modules could be as high as four. Thus, activities having a total export steam flow rate as high as 40,000 lbm/hr could be treated (75 percent). For a 20,000-lbm/hr module, 92 percent of the activities could be treated with four modules.

The actual total quantity of shore-to-ship steam production treated for the 20,000-lbm/hr module would amount to nearly 50 percent (Figure 26b). This would include 32 out of 34 home ports. The San Diego and Norfolk area provide the remaining 50 percent of steam to ships (Ref 5). More than four modules would be required.

However, the number of modules could be reduced by two. By merely doubling the heat exchanger tube length, which adds another 6 feet to the module length, the capacity is potentially doubled. However, redundancy should not be overlooked, as it resolves potential heat exchanger downtime.

Predicted Costs

The prototype IFSTEP is currently under construction. The cost of the system (one primary and one secondary unit) and its assembly is \$118k. The capacity of the unit, comprised of two modules, is estimated at 20,000 lbm/hr. Should the unit have twice the capacity, as suggested by small scale tests of the horizontal U-tube exchangers, then 40,000 lbm/hr is anticipated. If the heat exchanger tubing is doubled in length, then 80,000 lbm/hr could result, at less than a 20 percent increase in cost. The cost of a 100,000-lbm/hr unit would be near \$150k. The economic analysis estimated a cost of \$296k for the unit. Therefore, enormous cost savings (~50 percent for IFSTEP) may be realized with the prototype system, yielding a substantially more cost effective system than earlier predicted, greatly reducing the activity-dependent payback period. Actual cost savings will be established once the capacity is determined after the prototype field tests.

CONCLUSIONS

The IFSTEP field units were tested and evaluated in a variety of field conditions. They were appraised relative to their ability to produce high quality and dry steam. IFSTEP purifies steam at the plant or at selected points in the steam distribution system, where it is specifically required. NSTM quality steam can be generated using sodium zeolite ion exchangers (water

softeners), eliminating the need for labor intensive, high cost, reverse osmosis/de-mineralization and de-alkalization treatment, and avoiding hazardous material handling. In addition, IFSTEP has no electrical, water, or waste needs.

All the test data contained in this report are typical and exemplify thousands of hours of 1-minute recorded data. The performance and cost characteristics of IFSTEP, based on the bench, NCBC, and NAVWEAPSTA unit tests, led to the following conclusions.

IFSTEP Early Configuration

Earlier optimization tests suggested preferred heat exchanger orientation (Figures 5 and 6), separator and reservoir arrangement (Figures 5 and 6), control valve types (Figures 7 and 8), and subsequent IFSTEP designs of the NCBC unit and the NAVWEAPSTA unit (Figures 11 and 12).

Boundary Conditions

The boiler pressures and the ship steam demand are the boundary conditions to which IFSTEP must respond. The conditions experienced in the field were extreme and demanding (Figure 13) with step changes in steam demand and cyclic variations in pressure (± 20 percent).

NSTM Steam

Attempts to generate NSTM steam from different water treatments and from IFSTEP revealed: softeners alone cannot generate NSTM steam (Figure 1a); de-alkalizers can generate NSTM steam if low alkalinity is maintained (Figure 1b); IFSTEP does generate NSTM steam, no matter the condition of the feed water (Figure 1c).

IFSTEP Performance

- **Steam Purity**

To date, IFSTEP has produced NSTM steam consistently and continuously (Figure 14).

- **Thermodynamic Quality**

In all tests the product and byproduct steam dryness has always been above 99 percent (less than 1 percent of the steam is wet as exemplified in Figure 15). Typically, wetness in steam distribution systems is near 3 percent.

- **Capacity**

The actual capacity of the IFSTEP units has a consistent profile (Figure 16). The capacity of IFSTEP diminishes as the scale of IFSTEP increases (Figure 20). While

the IR/IED unit flow rate heat flux (scale = 1) was 35 lbm/hr/ft/ft, the NAVWEAPSTA unit flow rate heat flux (scale 135/1) is 13. The prototype design consisting of horizontal heat exchangers is expected to have a much greater capacity.

- **Internal Properties**

The liquid level in the surge tank and the control valve pressure difference are steady and constant (Figure 17). The byproduct (excess) flow is less than 10 percent (Figure 17a) of the feed flow, and values as low as 5 percent were observed. The D-PRV works exceptionally well (Figure 17b).

The pressures within the IFSTEP unit portray minimal losses (Figure 18), and the temperatures clearly show a decrease across the control valve (22.5°F) and a product growth to within 10°F of the feed temperature, yielding slightly superheated steam.

- **Startup Operations**

Startup operations of IFSTEP have progressively shortened to near 5 minutes (Figure 19). Moreover, a dry start up is preferred over a wet one to minimize any chance of cavitation or water hammer.

- **Heat Exchanger Effectiveness**

The effectiveness of the heat exchangers in the IFSTEP field units has gradually fallen to one-third of the early IR/IED units (Figure 20b). The horizontal heat exchangers, however, appear to surpass the effectiveness of the early IR/IED by 31 percent and the NAVWEAPSTA unit by potentially 100 percent.

Reliability, Availability, Maintainability

The IFSTEP field units have acquired nearly 2,000 hours of operation. Only a limited number of compromising events occurred. These events were resolved by avoiding certain components (e.g., PRV, three-piece ball valves) in the future designs or by modifying the component to circumvent the behavior (e.g., fixed tube sheets to a floating tube sheet to minimize leakage potential).

Costs

Field unit costs were slightly less than those estimated in the economic analysis (Ref 5), enhancing their viability. The vertical heat exchangers were the most costly component (Table 2).

Prototype Design

- **Configuration**

Based on superior performance (Figure 22a), the prototype design consists of two horizontal U-tube heat exchangers (Figure 23) instead of vertical two-tube sheet U-tubes. The single fixed-tube sheet of the U-tube allows unlimited tube expansion, is less cost, and has easy access to all components. Multiple units or modules can be interconnected through common headers. Each module is identical. One module of a group has a control valve (Figure 23).

- **Predicted Capacity**

- **Modules.** The capacity of each module should be at least 10,000 lbm/hr, but the unit is sized for twice that, in light of the doubling capacity of horizontal heat exchangers over vertical ones.

- **Navy-Wide Needs.** Modules of 10,000-lbm/hr capacity should meet the needs of 75 percent of the activities, if up to four modules are used. Ninety-two percent of the activities could be treated if the capacity of each module is doubled, as expected. By lengthening the heat exchanger tube length an additional 6 feet, again doubling the capacity, all Navy needs could be met at all the activities.

- **Predicted Costs**

The costs of the prototype horizontal heat exchanger module are nearly 30 percent less than the vertical unit (Tables 2 and 3) and the unit estimated in the economic analysis (Ref 5). If the prototype capacity is twice the vertical, as expected, and if the heat exchanger tube length is doubled (another doubling of flow), then the costs of the 100,000-lbm/hr system are potentially reduced by one-half compared to the assumptions in the economic analysis. The already cost-effective IFSTEP unit has a substantially reduced payback. The capital costs are expected to be in the range of \$1,500 per 1,000 lbm/hr. There are no utility needs, and there are no moving parts other than a D-PRV. These expectations can be definitively determined when the prototype field trials are completed.

RECOMMENDATIONS

Based on all previous testing, as summarized in this report, the following recommendations evolved:

- Conduct field trials of the prototype design as planned. IFSTEP contains all previous improvements, using the described horizontal heat exchanger module design. Establishing capacity defines sizing and cost requirements.
- Conduct long-term tests with the prototype modularized system to identify the certainty needed in the RAM data.

While the first recommendation identifies the important capacity of the prototype, the second quantifies its long-term effectiveness. Both can significantly improve or adversely impact the early economic analysis (Ref 5).

REFERENCES

1. Naval Sea Systems Command. NAVSEA S9086-GS-ST-020/CH 22D: Naval ship technical manual, volume II. Washington, DC.
2. G.L. Murphy. "Impure steam flow," Chemical Propulsion Information Agency, Pub 517, Johns Hopkins University, vol I, Jun 1989, pp 83-03.
3. Naval Civil Engineering Laboratory. Technical Note N-1802: Two-phase impure steam flow, by G. L. Murphy. Port Hueneme, CA, Nov 1989.
4. G.L. Murphy. "Purifying shore-to-ship steam," Third Annual IR/IED Annual Symposium, Silver Spring, MD, Jun 1990.
5. Naval Civil Engineering Laboratory. TM 53-92-03: Shore-to-ship steam purification economic analysis, by Eugene Cooper, et al. Port Hueneme, CA, Sep 92.
6. Naval Civil Engineering Laboratory. TM 53-92-02: Validation tests shore-to-ship steam purification, by G. L. Murphy. Port Hueneme, CA, Sep 92.
7. Naval Facilities Engineering Service Center. TM-2063-SHR: Shore-to-ship steam purification, IFSTEP optimization, by G. L. Murphy and S. Maga. Port Hueneme, CA, Jun 94.
8. Naval Facilities Engineering Service Center. TM-2053-ENG: Shore-to-ship steam purification, NCBC field unit tests, by G.L. Murphy and S. Maga. Port Hueneme, CA, Jun 94.
9. Naval Facilities Engineering Service Center. TM-2135-SHR: Shore-to-ship steam purification NAVWEAPSTA Concord tests, by G.L. Murphy and S. Maga. Port Hueneme, CA, Apr 95.
10. Department of Defense. DOD Military Handbook 1025/2: Dockside utilities for ship service. Washington, DC, May 1988.

11. Naval Facilities Engineering Service Center. Technical Memorandum TM-2144-SHR: Shore-to-ship steam purification, IFSTEP performance with horizontal heat exchangers, by G.L. Murphy. Port Hueneme, CA, Sep 94.

Table 2. NWS - 10k Unit Costs

Item	Description	Quantity	Costs
Materials			
Heat Exchangers	350ft2/each	2	33,200
Surge Tank	100 gal. tank	1	2040
Separator	4 " inlet	1	2,830
Control Valves	Electronic	1	4575
	Mechanical	1	2030
Valves	Ball and Globe	8	4853
Skid	5'x10'	1	1250
	Total		50,778
Fabrication/Assembly			
	Total		34000
Total			84,778

Table 3. NSC - 20k Unit Costs (2 Modules)

Item	Description	Quantity	Costs
Materials			
Heat Exchangers(U-tube)	348ft2/each	4	34,000
Surge Tank	100 gal. tank	1	2040
Separator	4 " inlet	1	2,300
Control Valves	Electronic	1	4664
	Mechanical	1	2030
Valves	Ball and Globe	29	12,600
Insulation	na		5,000
Skid	5'x10'	2	3500
	Total		66,134
Fabrication/Assembly			
	Total		52000
Total			118,134

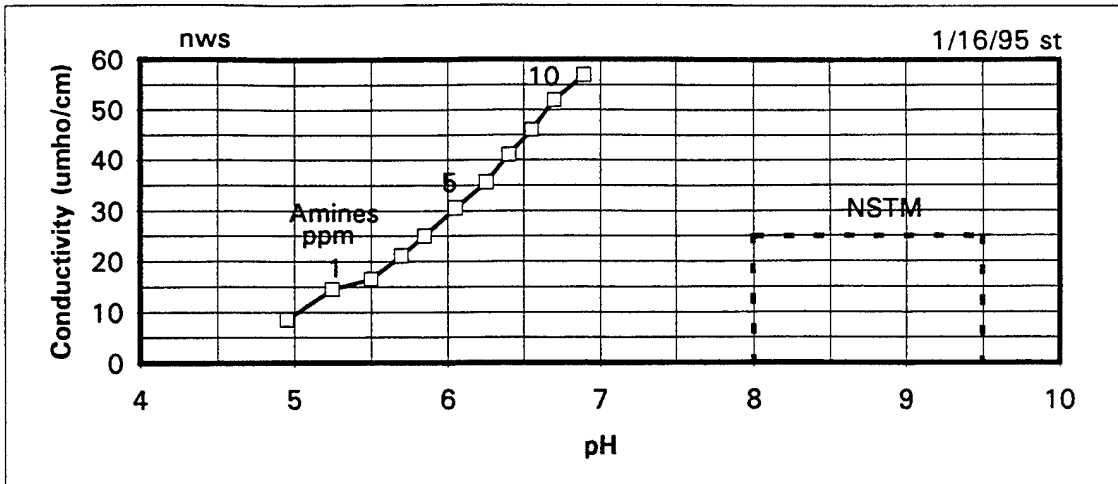

a) Water Softening and Amine Addition

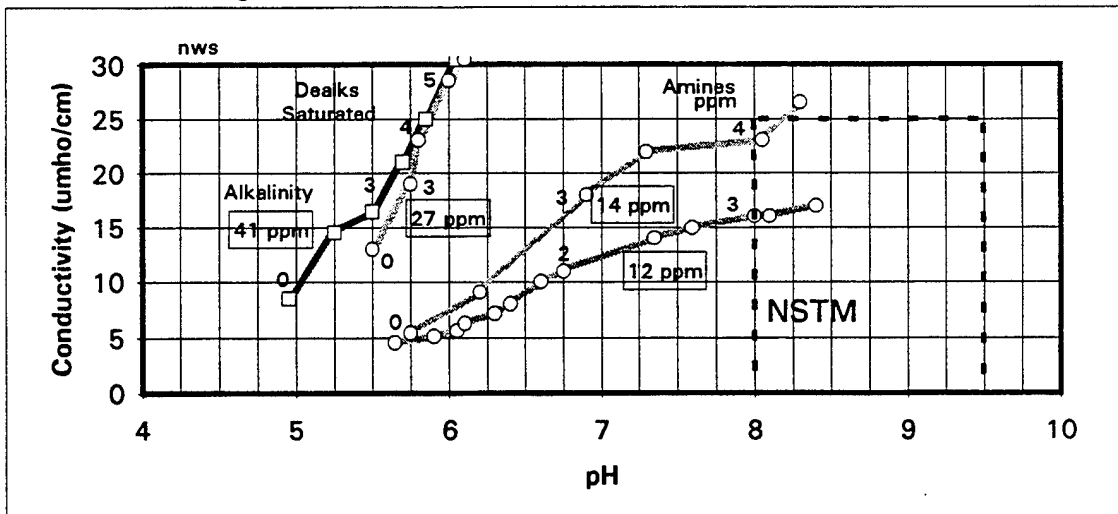

b) Dealkalizer and Alkalinity States

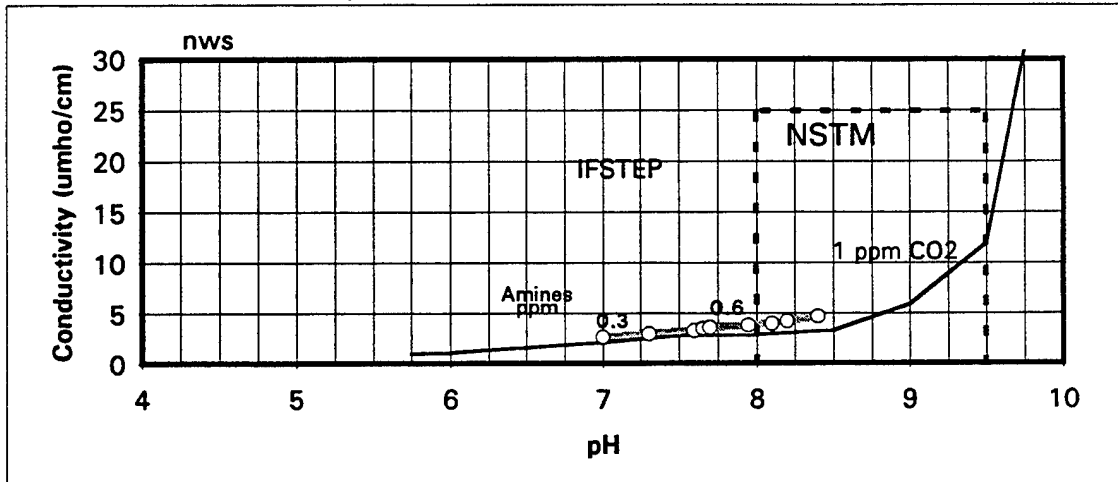

c) IFSTEP

Figure 1
Steam production with various boiler water treatments.

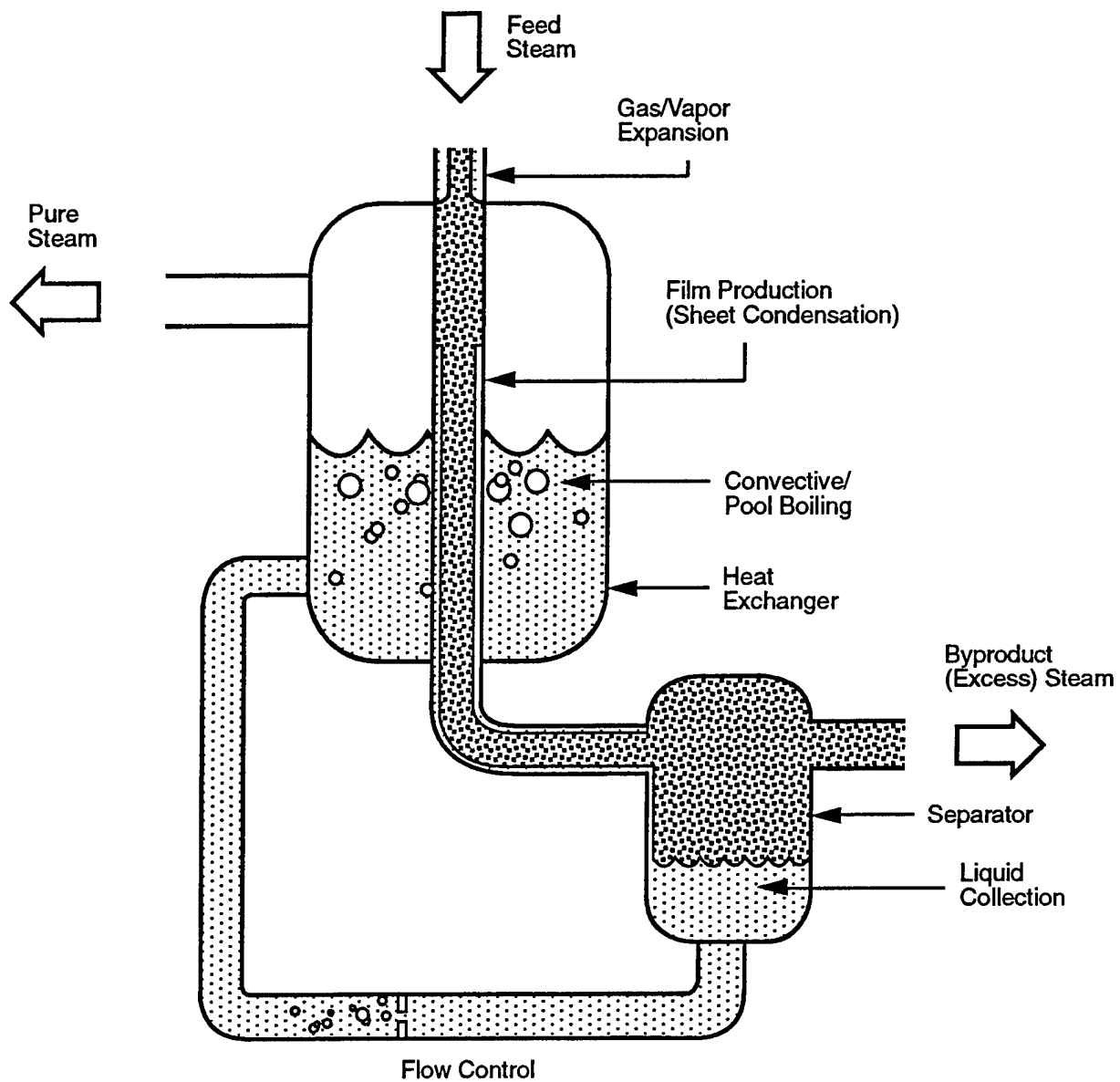

Figure 2
 Inverse flash steam purifier (IFSTEP): Steam purification concept.

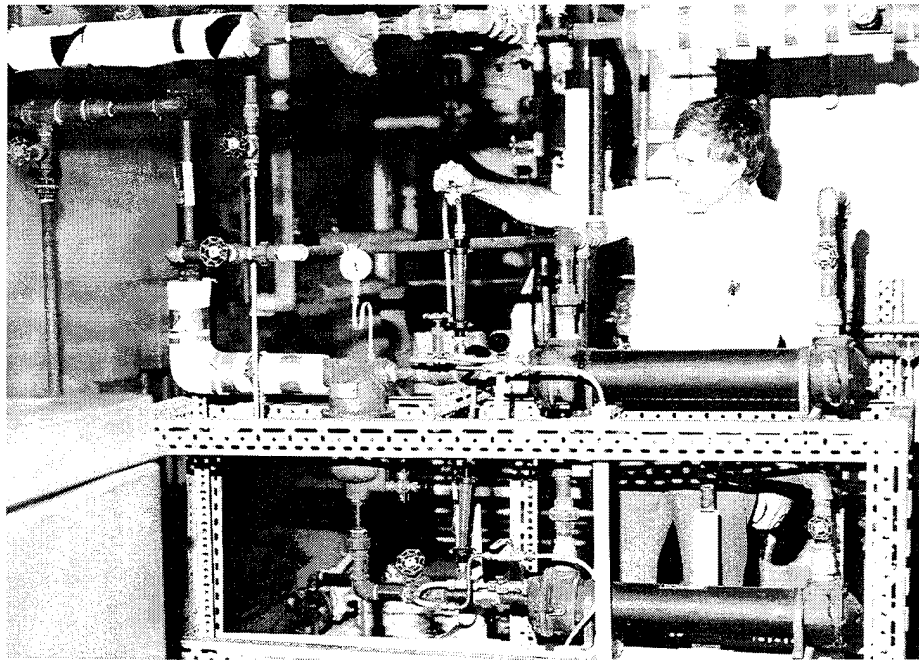

Figure 3
Early tests with 2.53 ft² area heat exchanger (scale = 1).

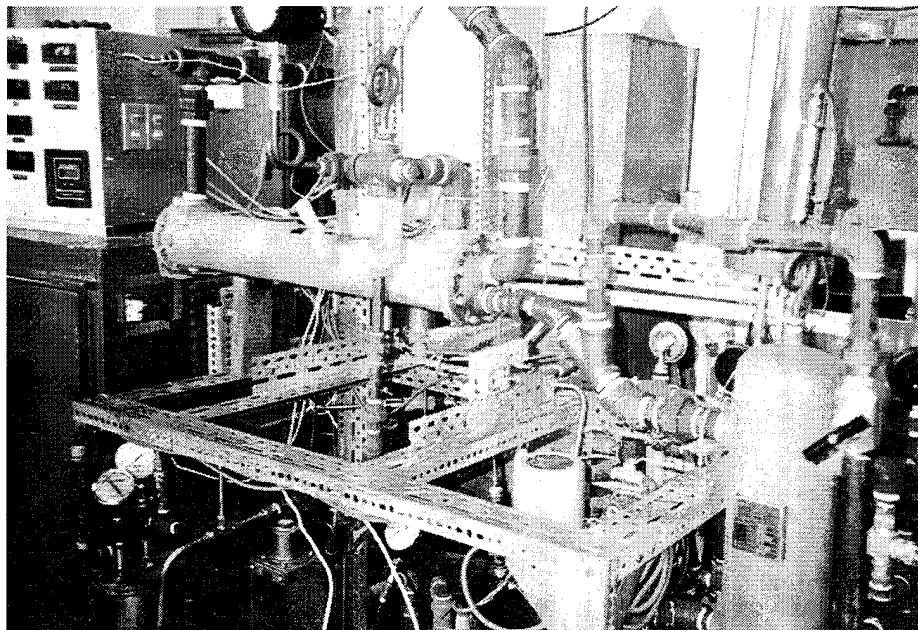
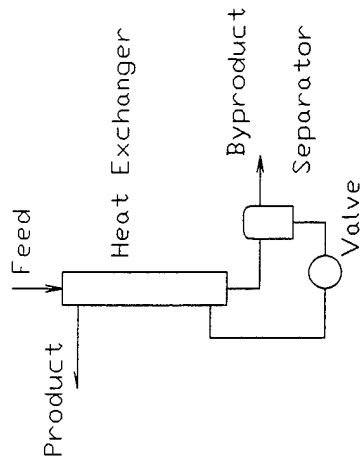
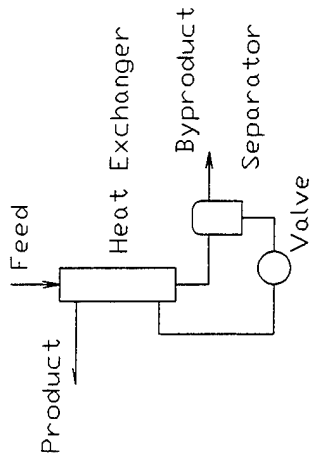

Figure 4
Optimization tests with 26 ft² heat exchanger (scale. ~10/1).



o 36 inch Hx



o 27 inch Hx

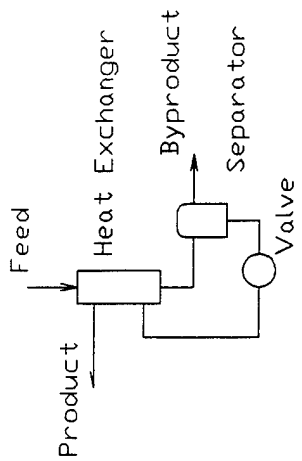

o 18 inch Hx

a) Hx Lengths

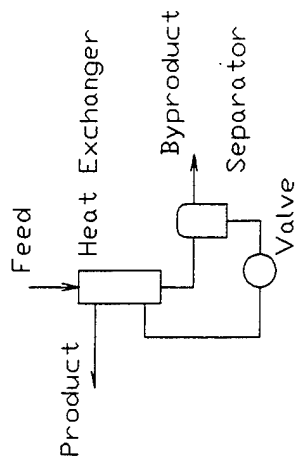

o Vertical

b) Hx Orientation

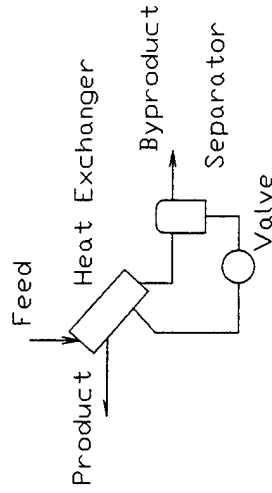

o Incline (45 degrees)

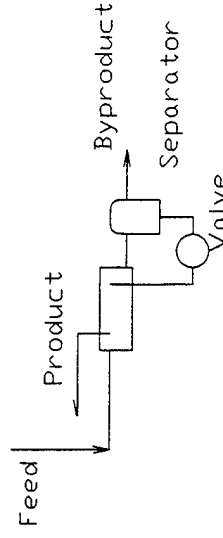

o Horizontal

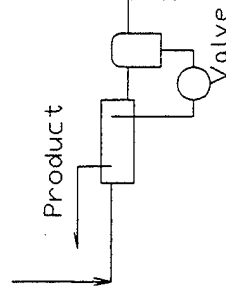

o Single Pass

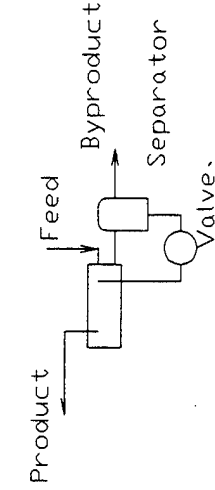

o Two Pass

Figure 5

Heat exchanger variations tested.

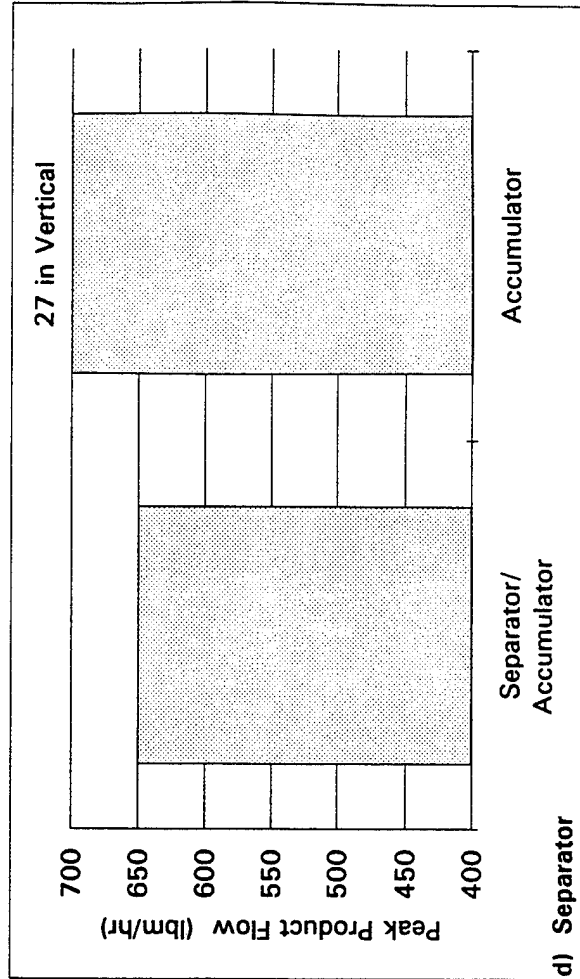
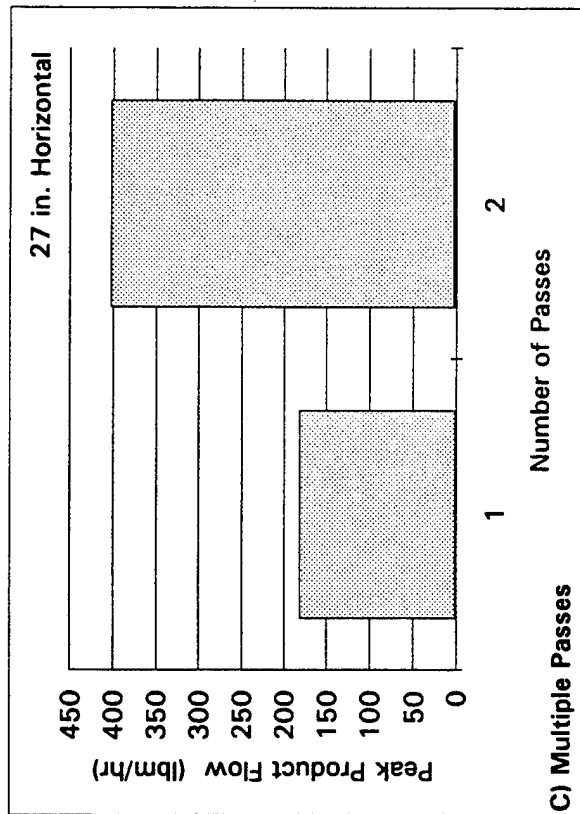
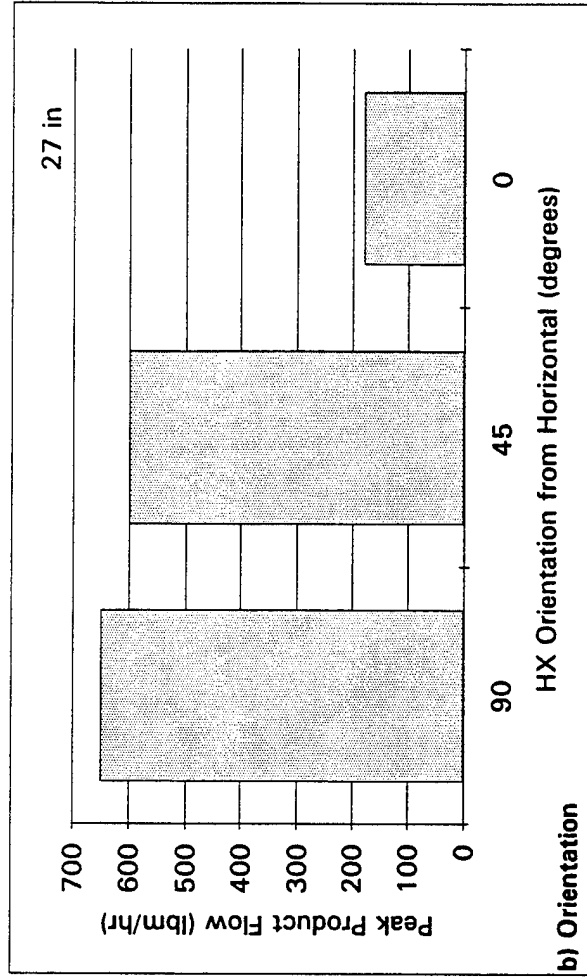
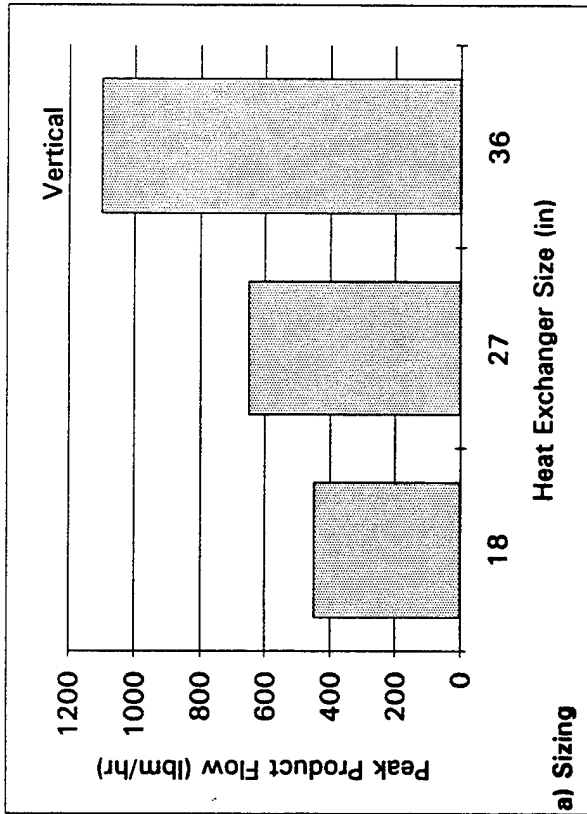
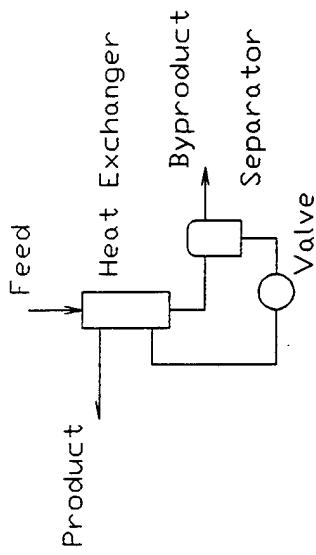
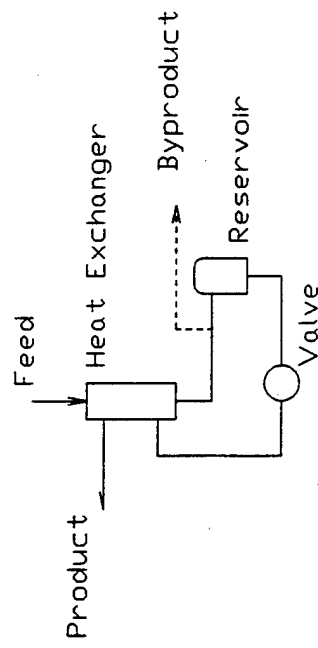

Figure 6 Peak product flow influenced by heat exchanger size, orientation, passes, and the separator.



a) Separator



b) Flow Redirector/ Reservoir

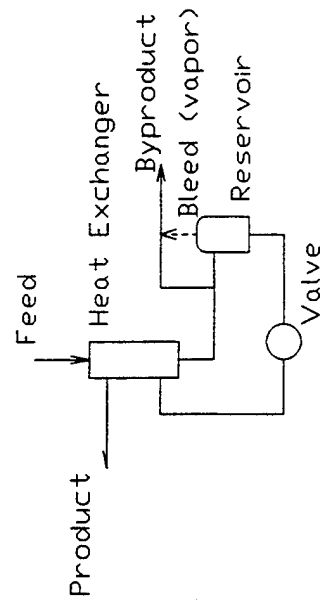

c) Bleed Addition

Figure 7
Evolution of separation improvement.

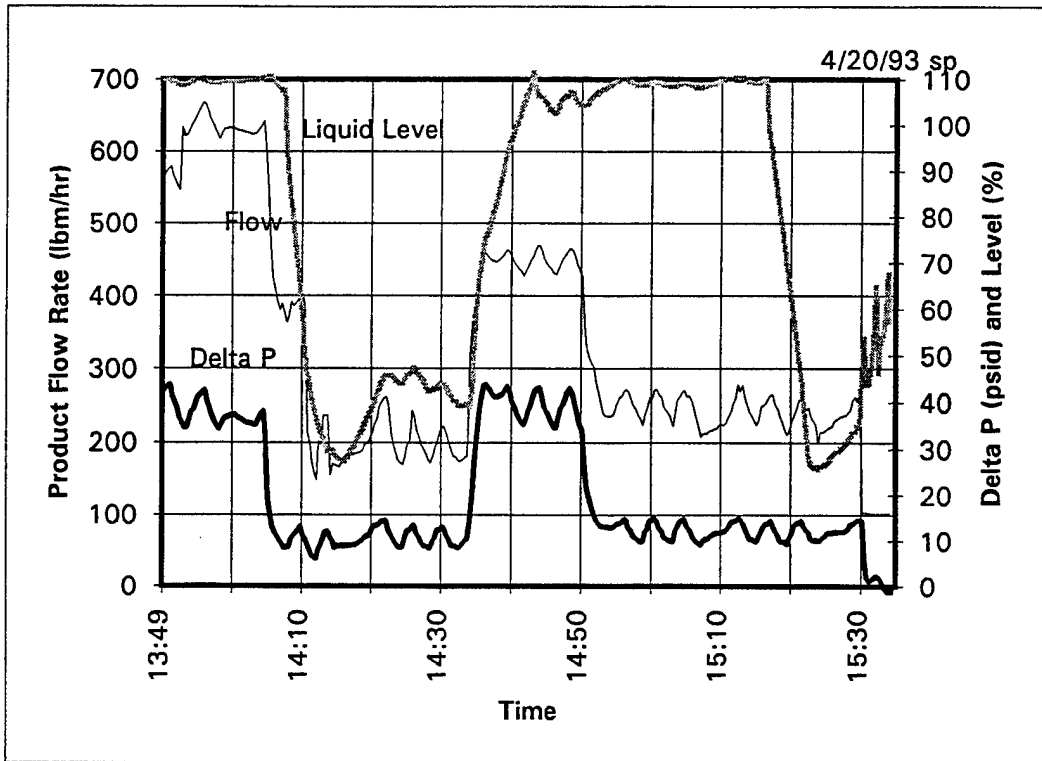

a) Fixed Valve or Orifice Control

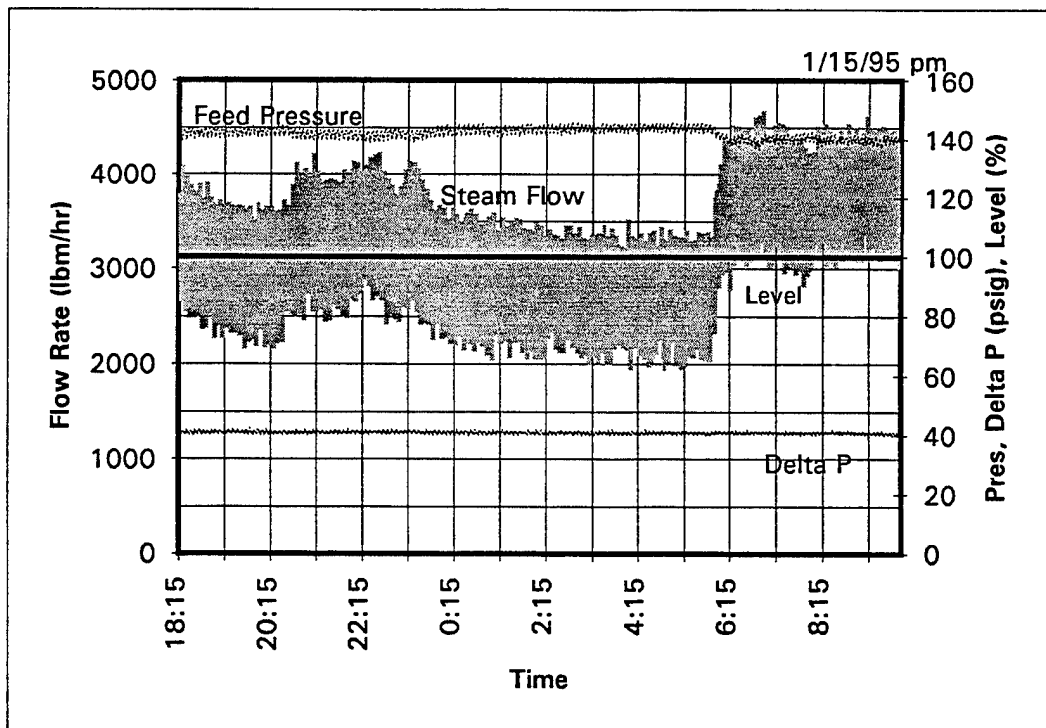

b) Differential-Pressure Regulating Valve

Figure 8
Controlling the pressure (temperature) across the heat exchanger.

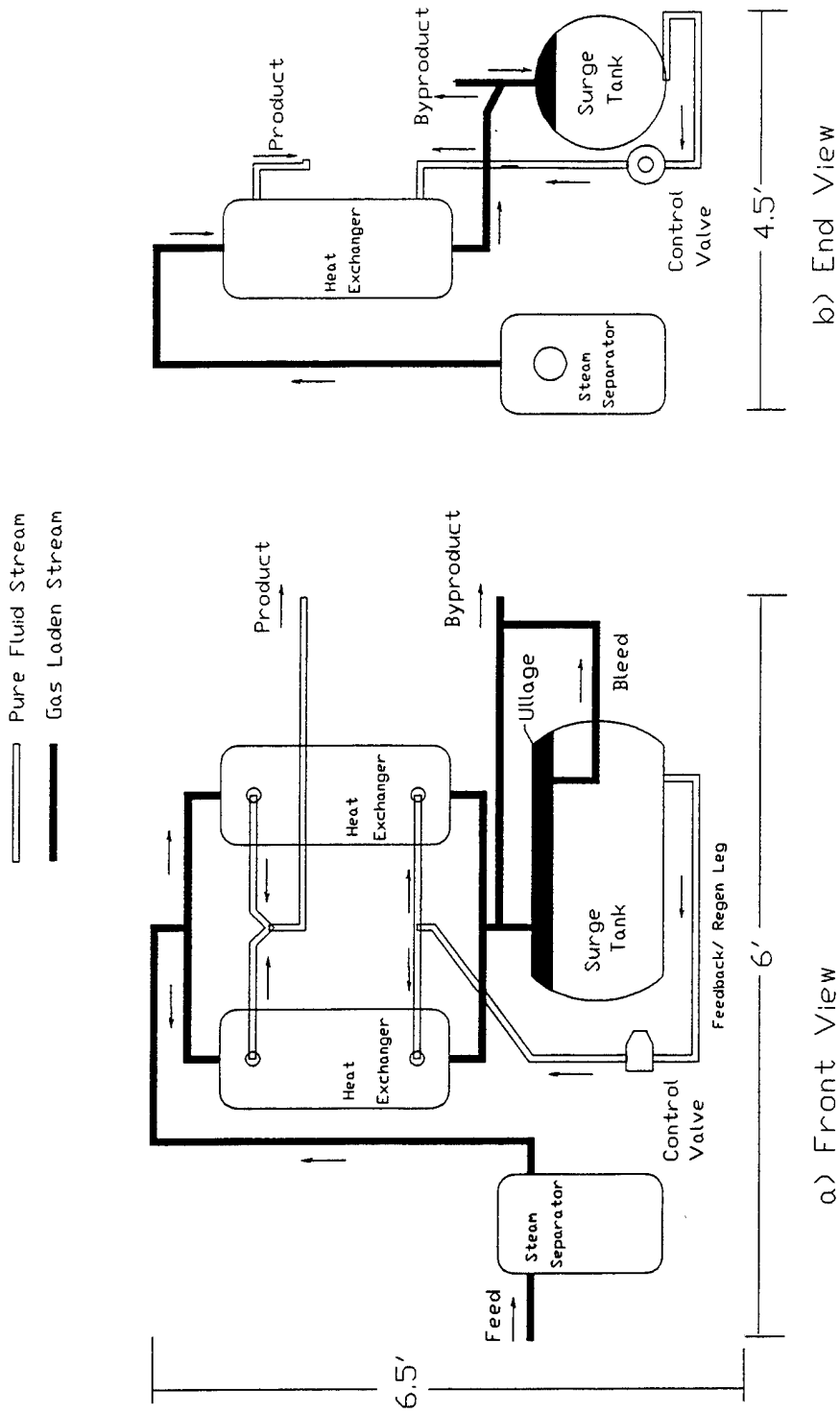

Figure 9
NCBC IFSTEP field unit schematic.

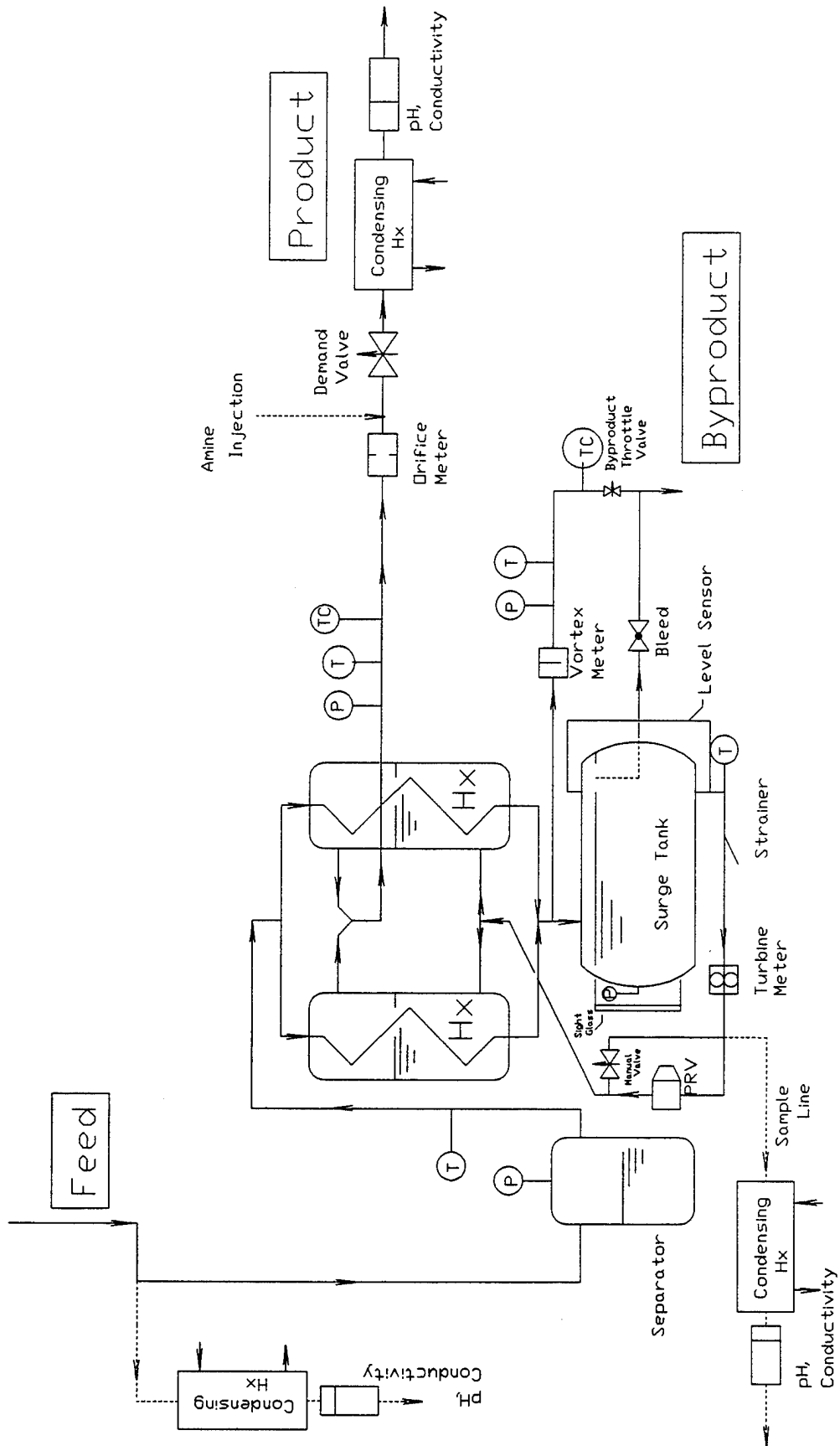

Figure 10
Instrumentation schematic.

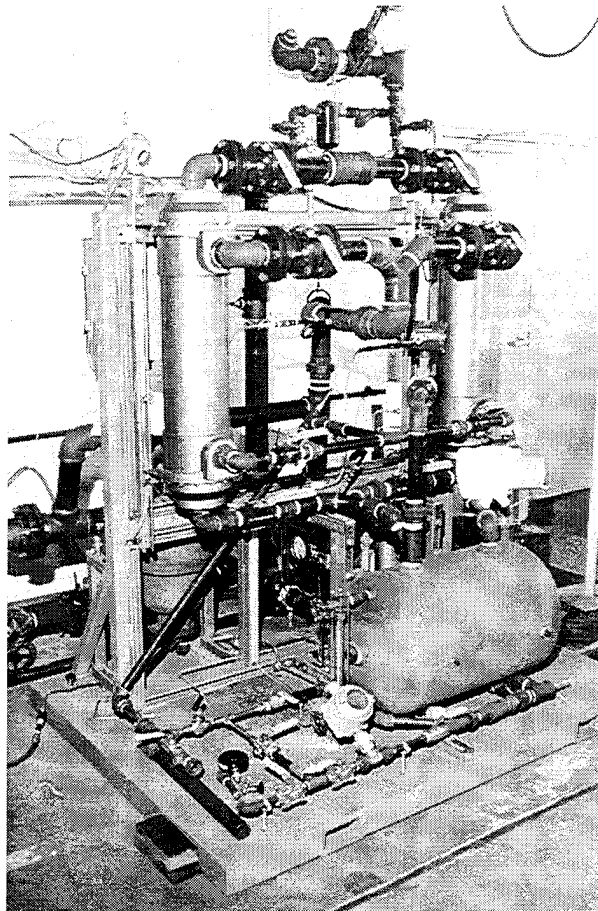

Figure 11
NCBC field unit (scale = 26/1).

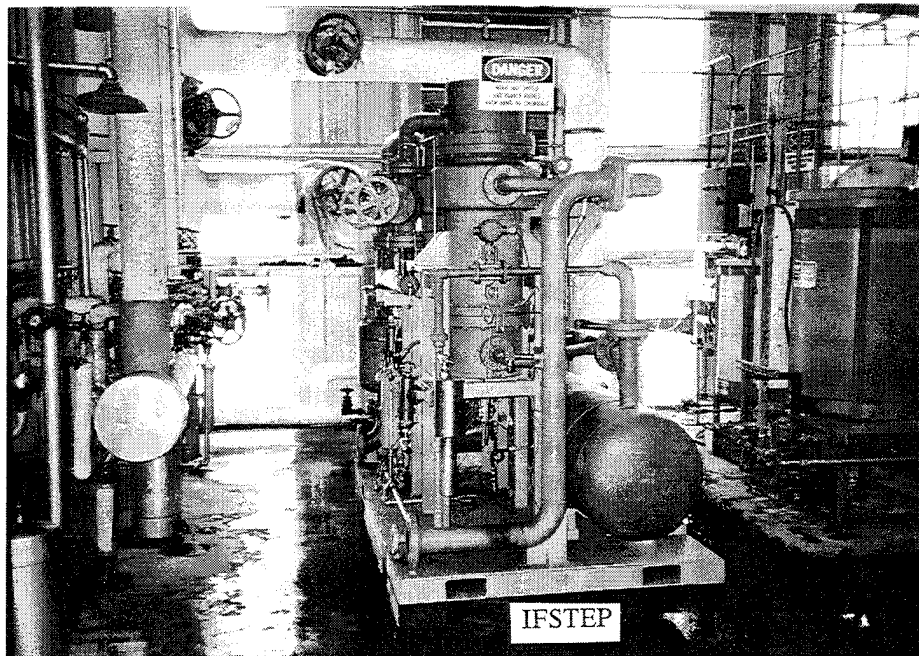
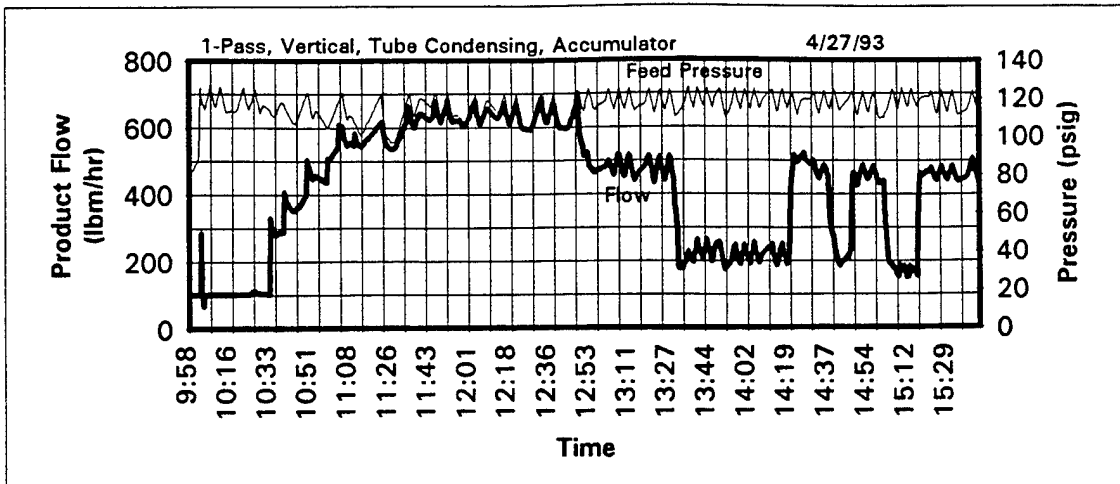
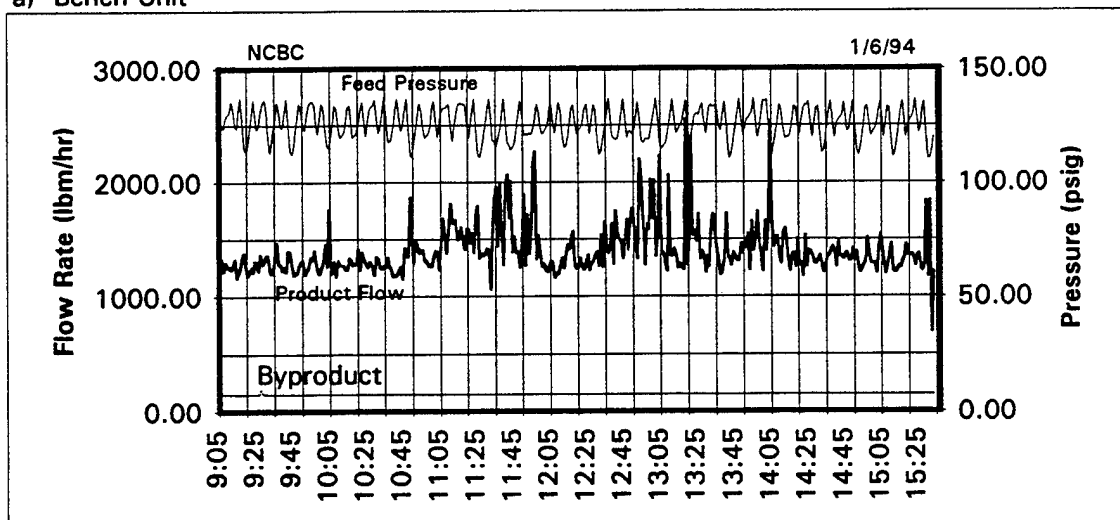

Figure 12
NAVWEAPSTA Concord field unit: end view (scale = 135/1).



a) Bench Unit



b) NCBC Field Unit

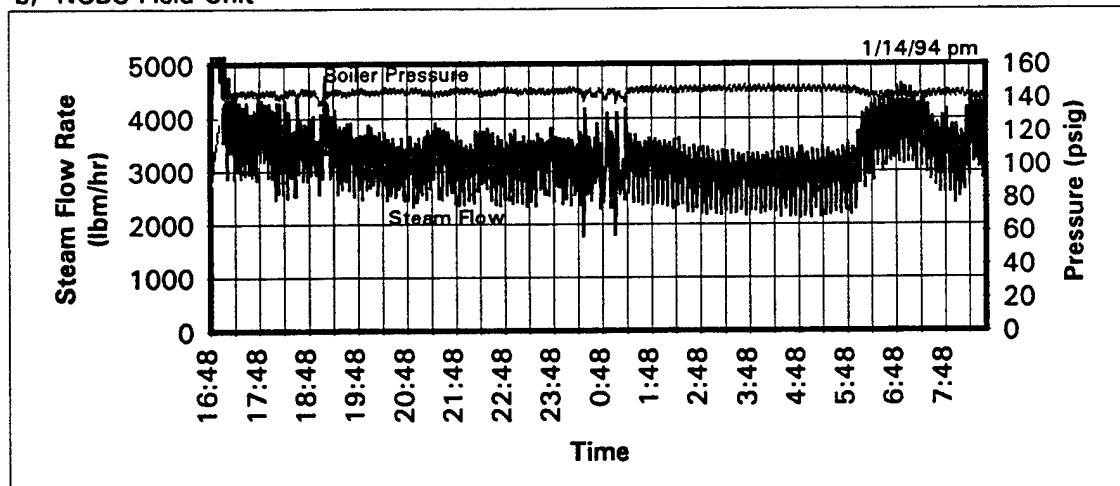

c) NWS Field Unit

Figure 13
Different field boundary conditions.

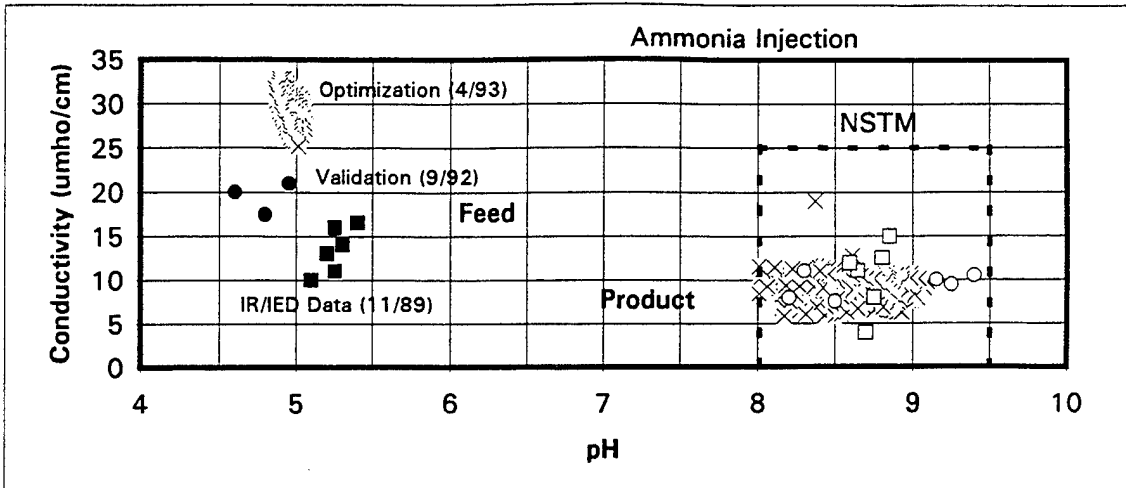

a) Early Tests

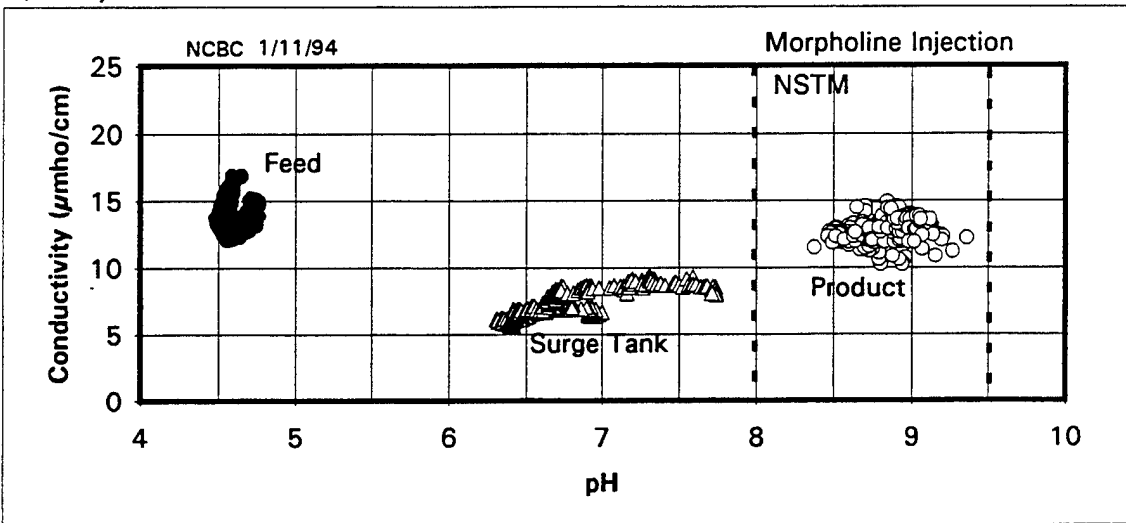

b) NCBC Field Tests

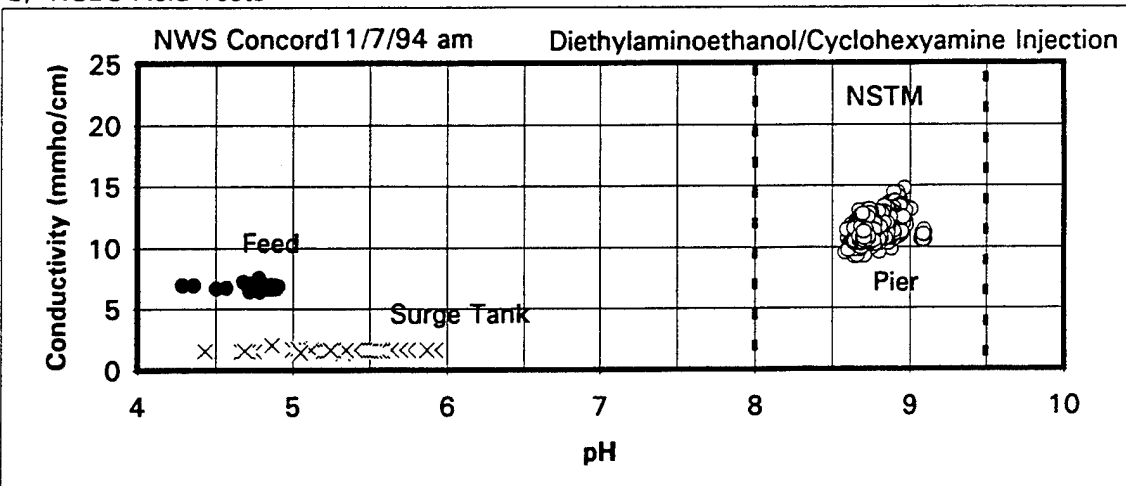

c) NWS Concord

Figure 14
Steam purity maps of IFSTEP units with amine injection.

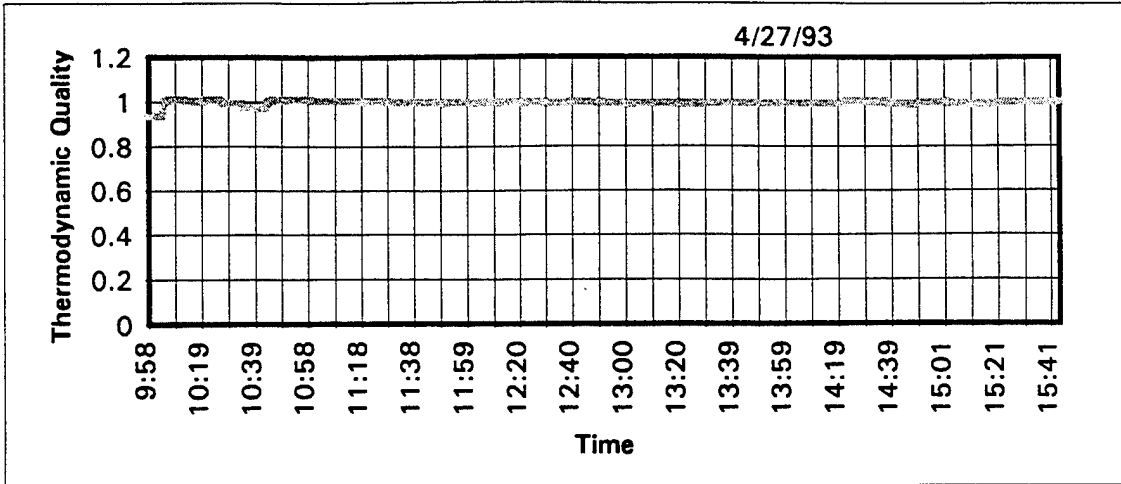

a) Bench Model

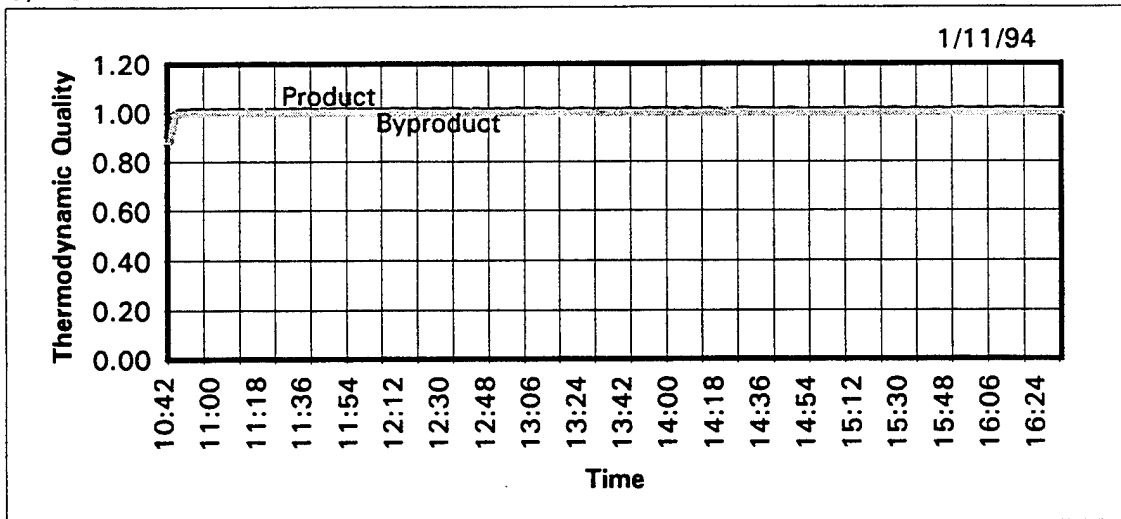

b) NCBC Field Unit

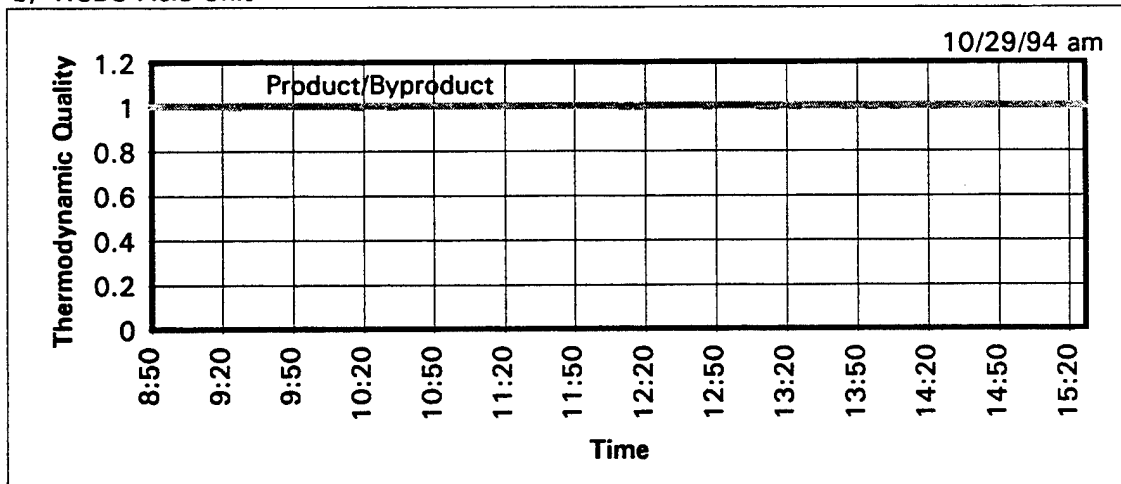

c) NWS Concord Field Unit

Figure 15
Thermodynamic quality (dryness) of IFSTEP units.

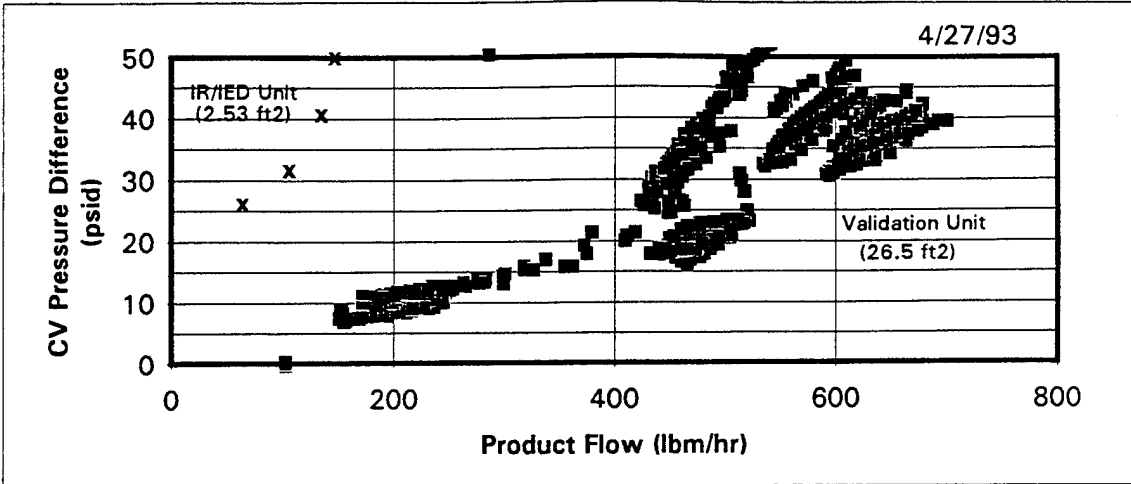

a) Bench Unit

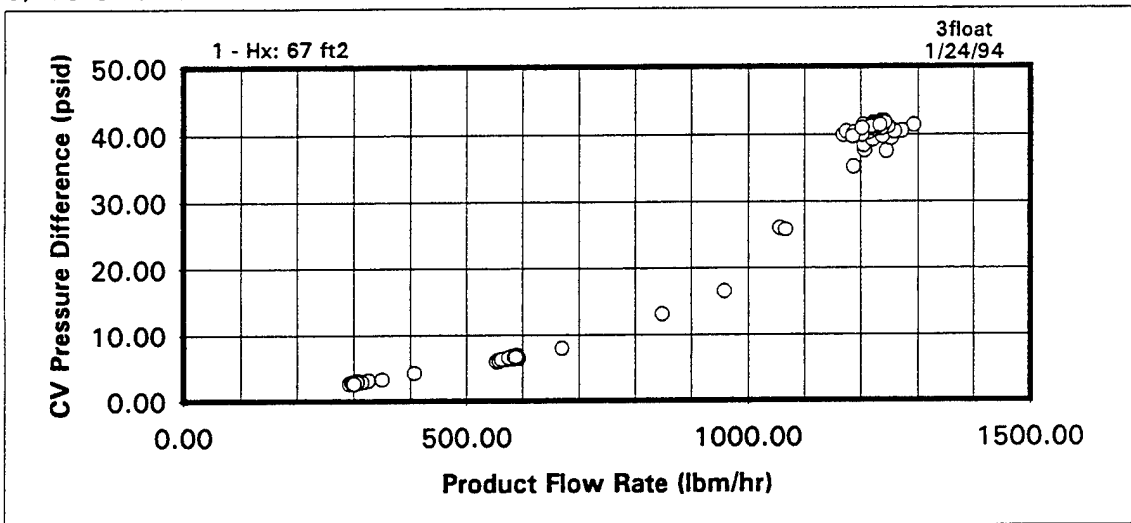

b) NCBC Field Unit

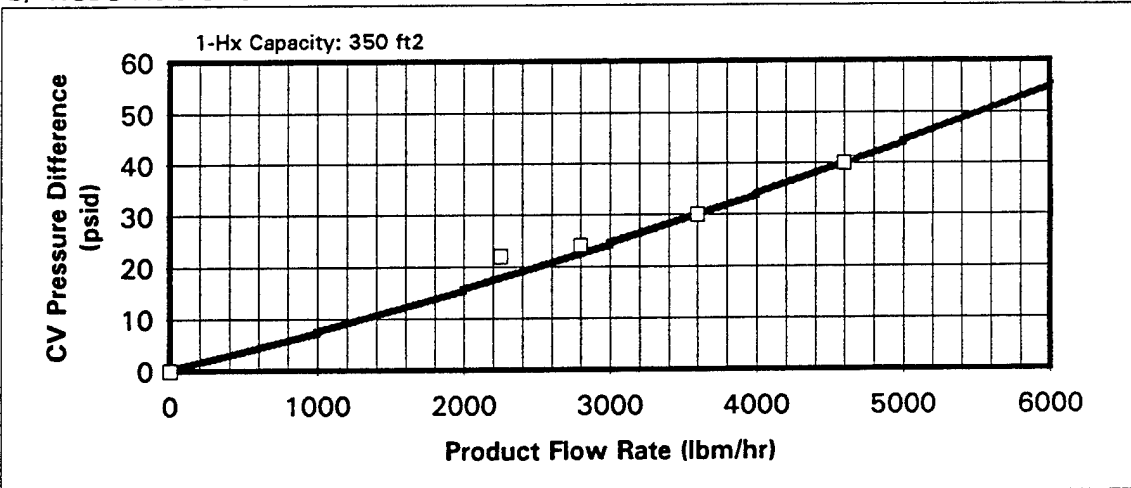

c) NWS Concord Unit

Figure 16
Growth in IFSTEP capacity.

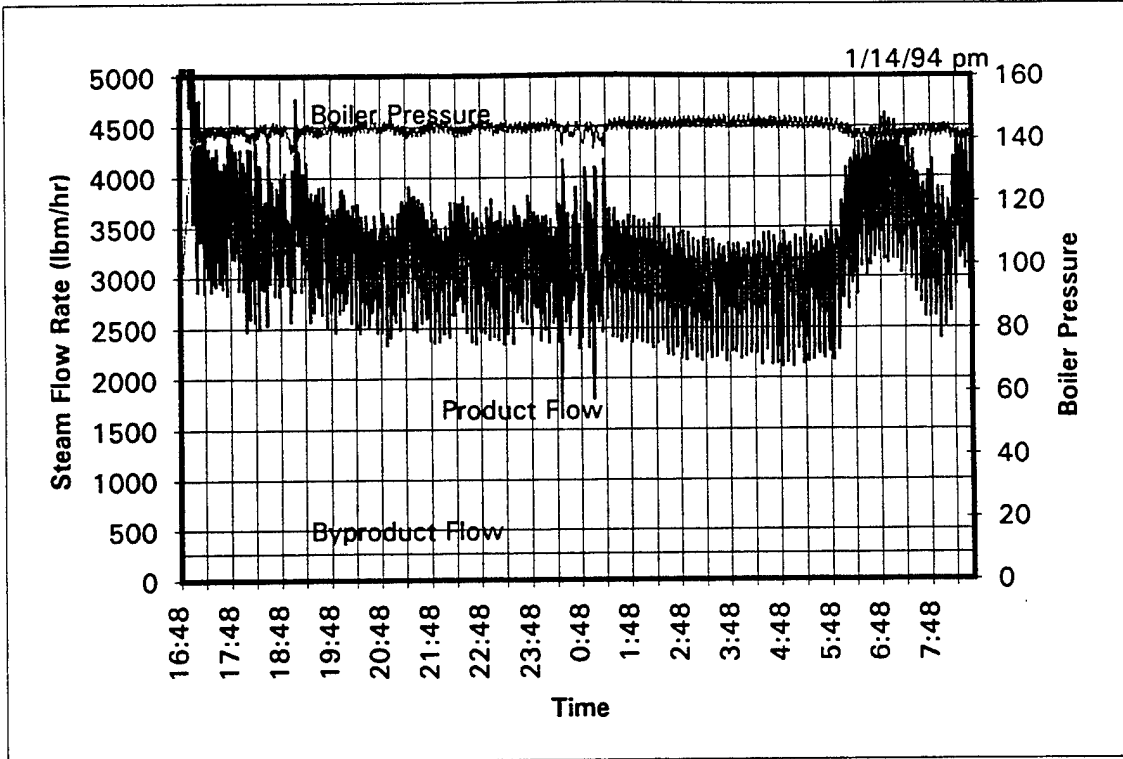

a) Boiler Export Steam Flow and Pressure

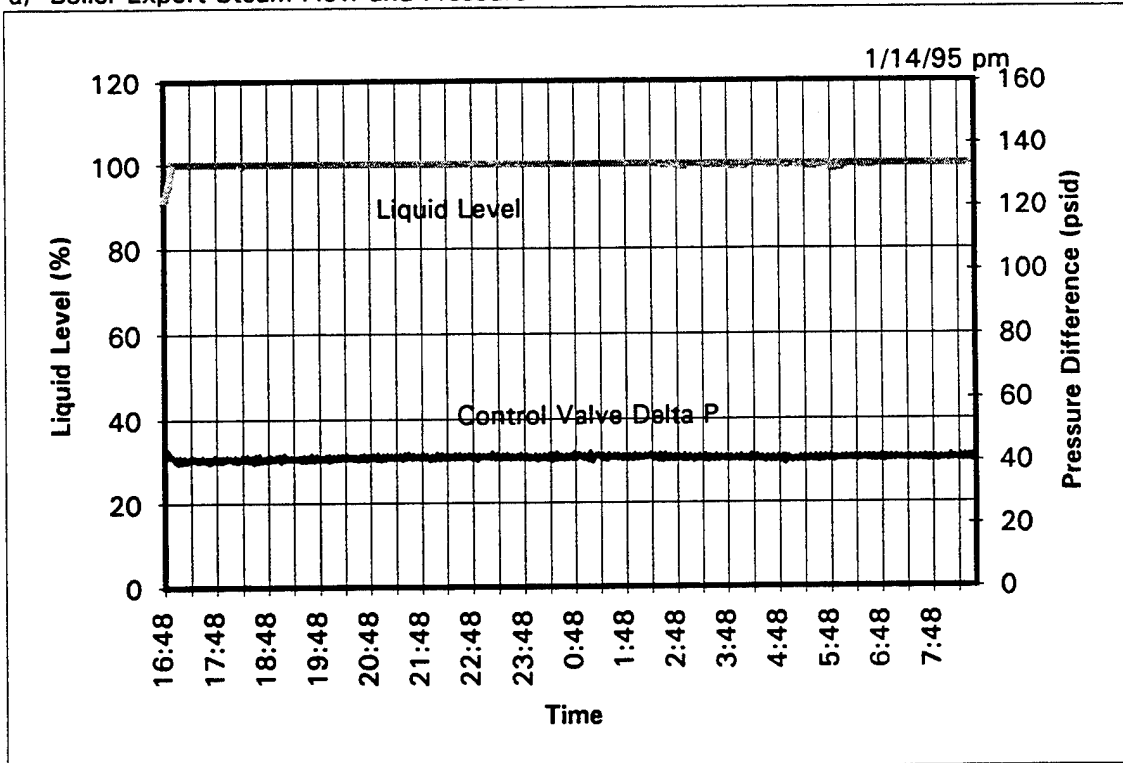

b) Control Valve Pressure and Surge Tank Reservoir Level

Figure 17
Boundary conditions and internal properties.

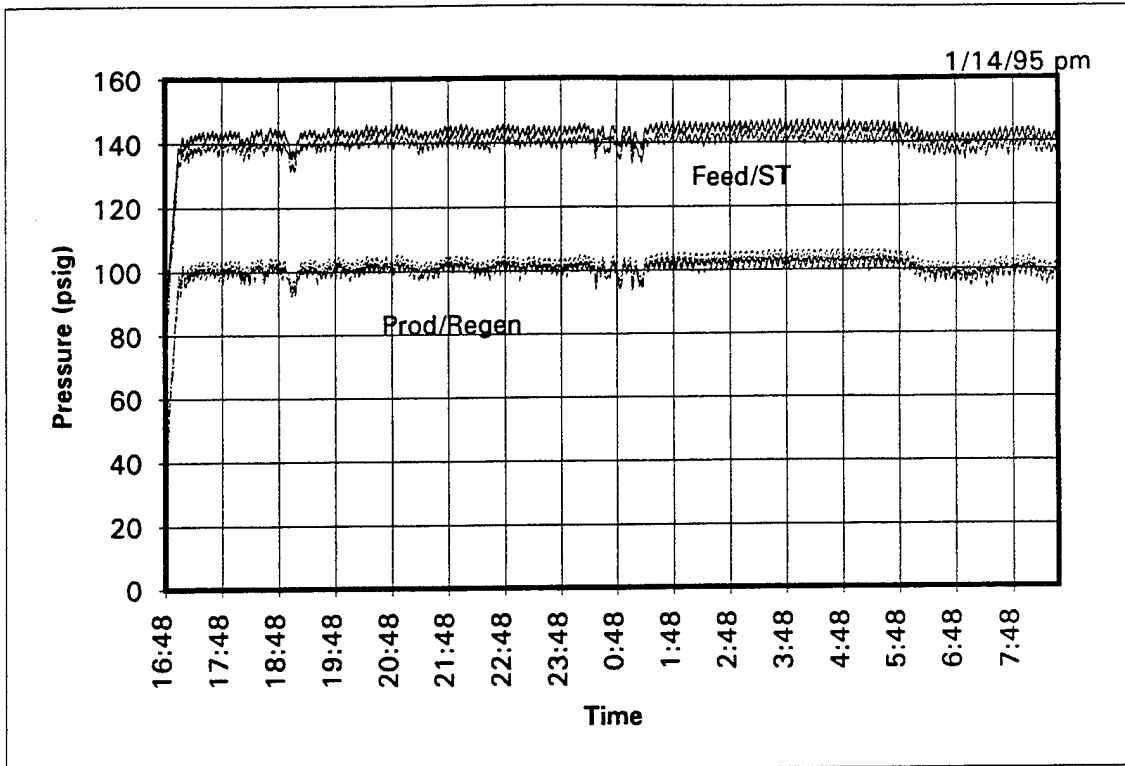

a) Pressure

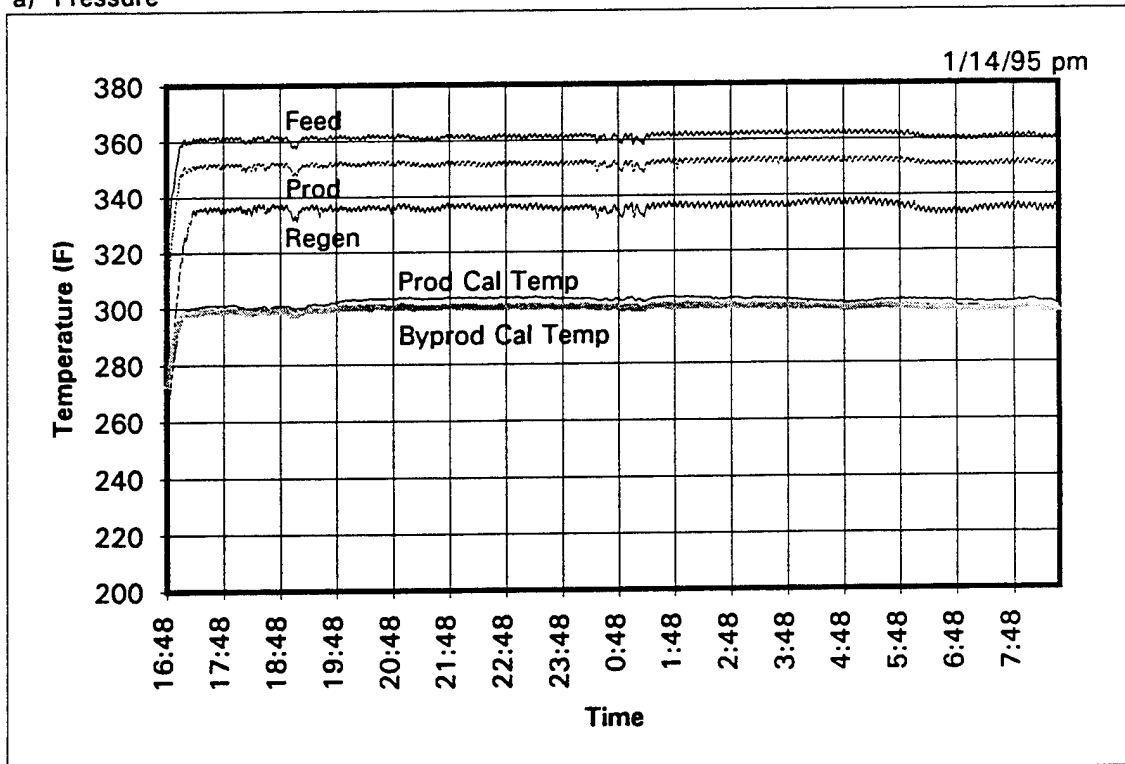

b) Temperature

Figure 18
Internal pressure and temperature excursions (typical).

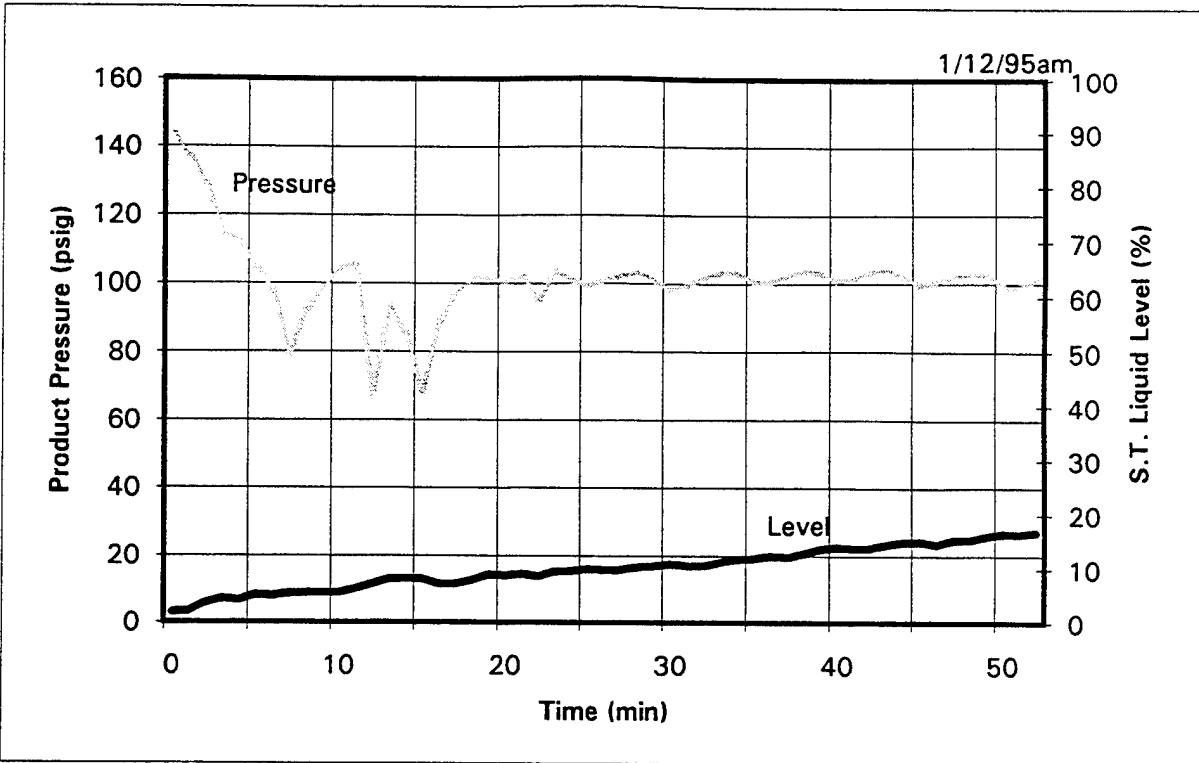

a) Liquid Level Rise and Product Pressure Transient

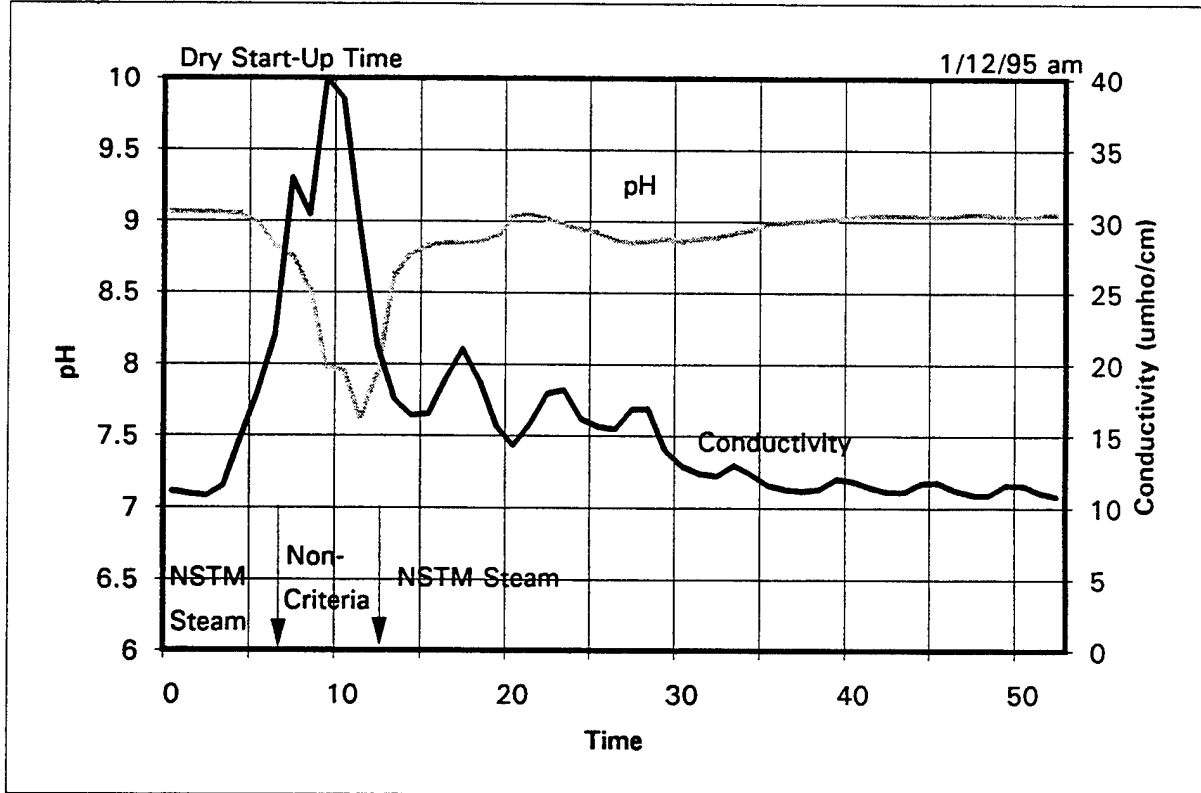

b) Generating NSTM Steam

Figure 19
IFSTEP startup when unit dry: NWS unit.

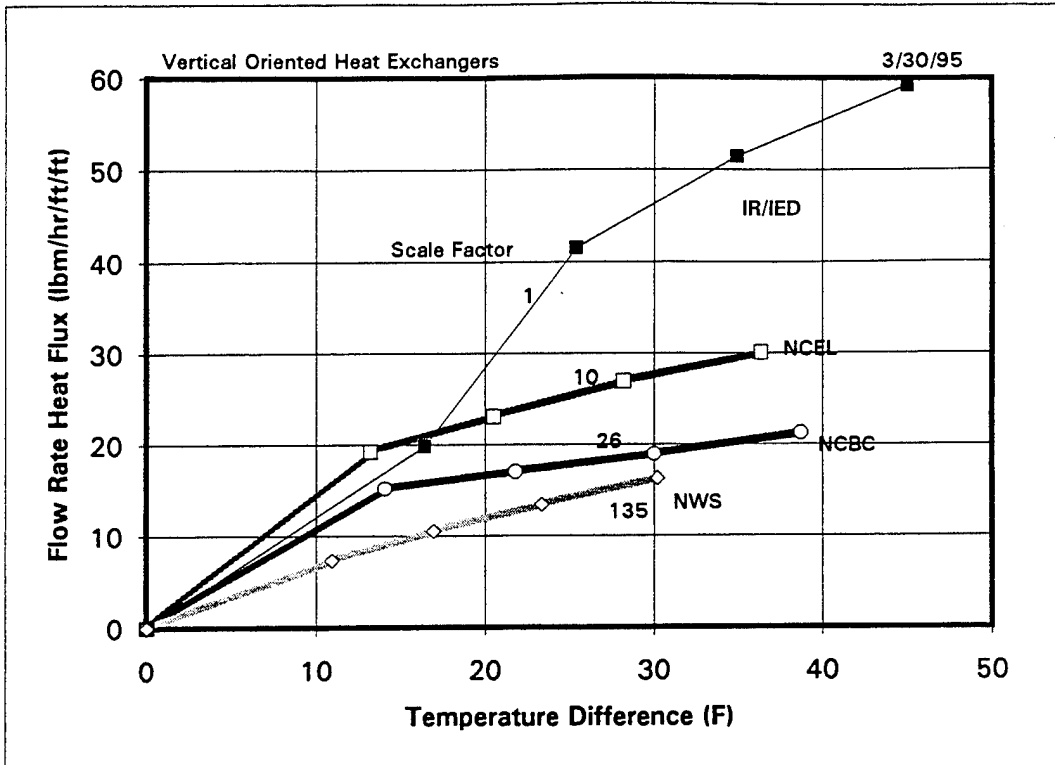

a) Flow Heat Flux Varying With Tube/Shell Temperature Difference

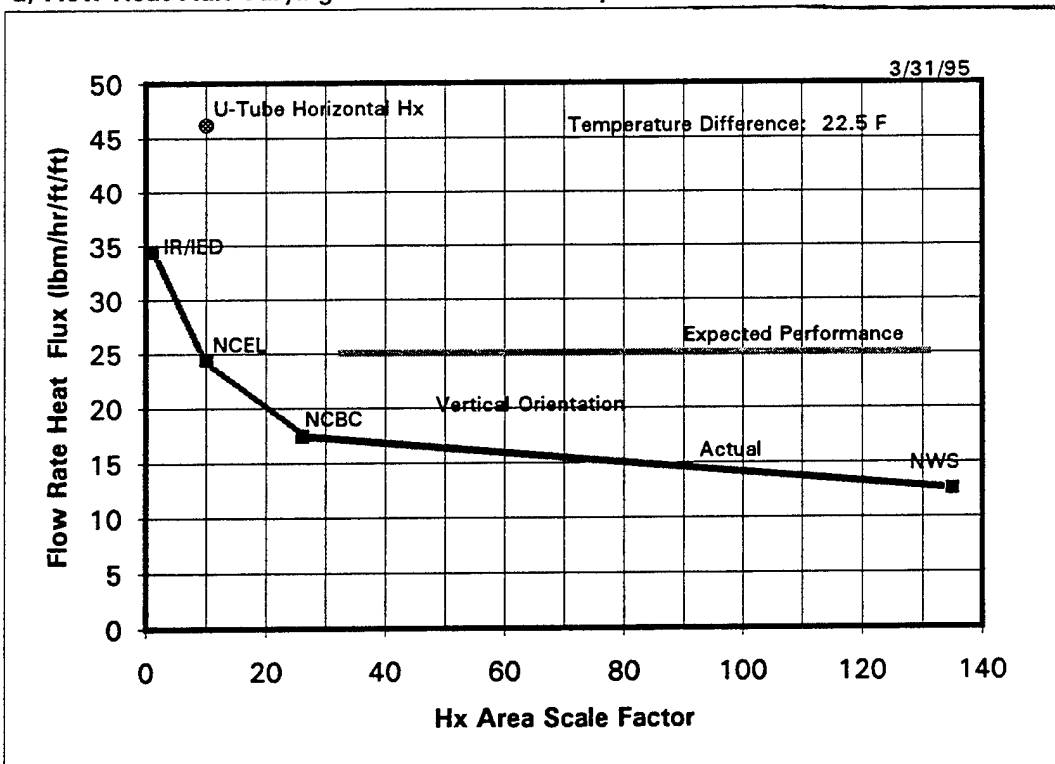

b) Flow Heat Flux and Scaling Factor

Figure 20
Flow rate heat flux of heat exchangers.



Conventional (Conv)



2 Pass



Side by Side (s-s)

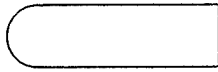

U - Tube



4 Pass



Over/Under (o/u)

a) Hx Types

b) Passes

c) Tube Port Positions

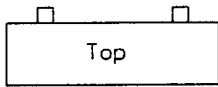

Top

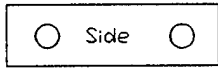

Side

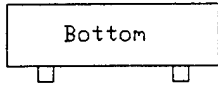

Bottom

d) Shell Port Position



Wide



Narrow

e) Baffle Spacing



Vertical



Horizontal

f) Baffle Orientation

Figure 21
Hx configurations.

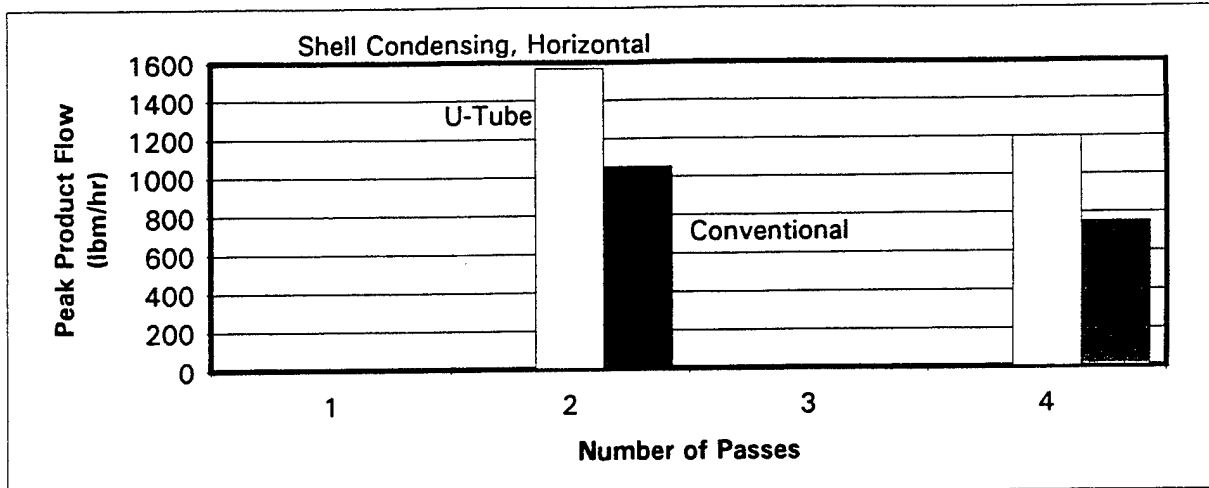

a) U-tube and Conventional Heat Exchangers

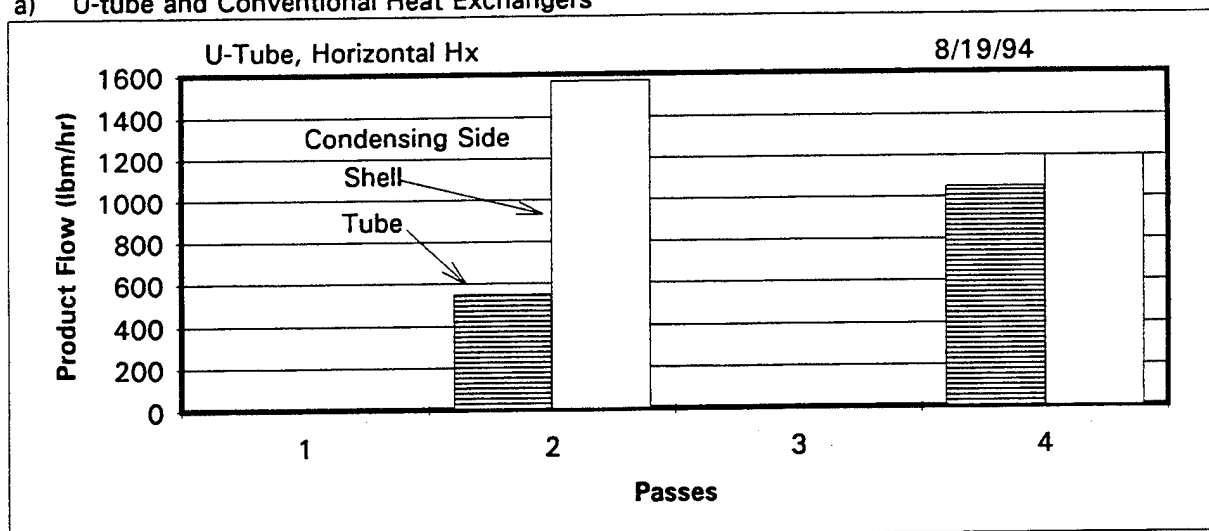

b) U-tube, Shell and Tube Side Condensing

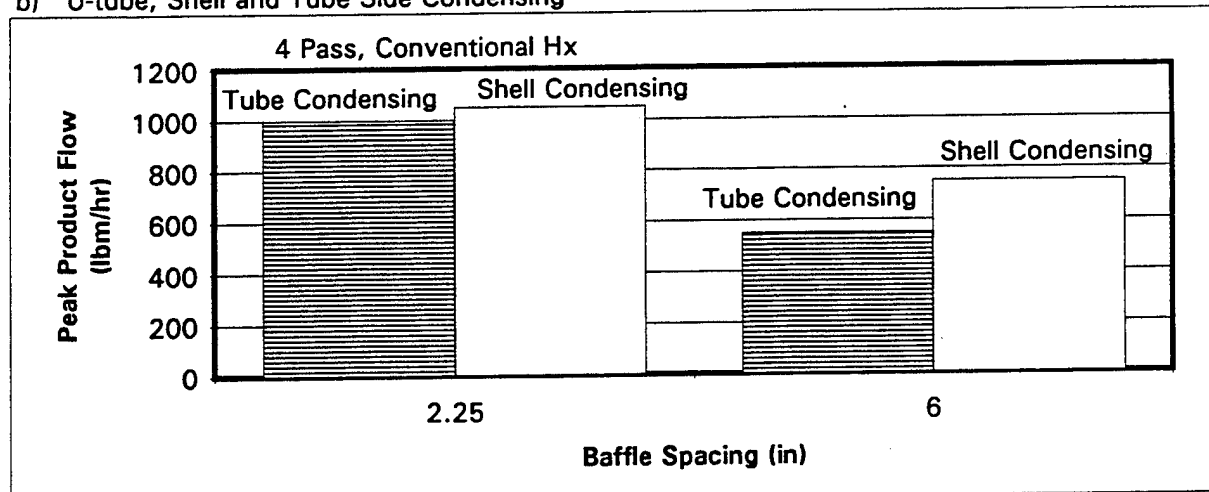

c) Influence of Baffle Spacing

Figure 22
Horizontal heat exchanger performance (10/1 scale).

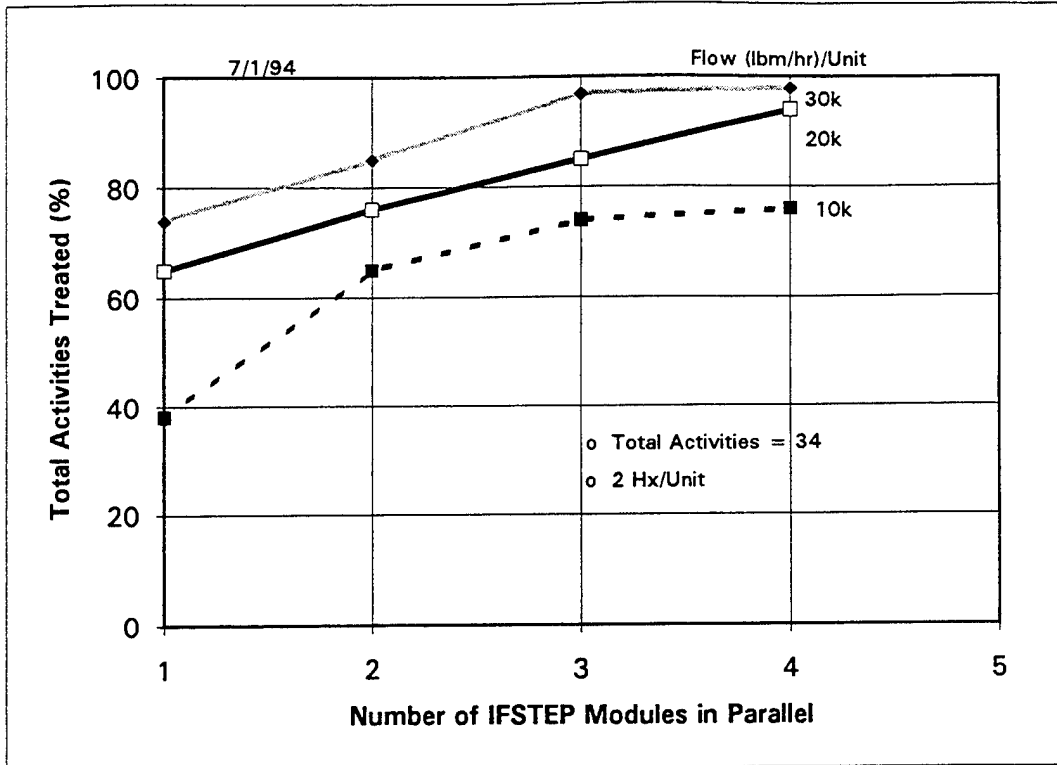

a) Module Capacity and Treatment of Total Activities

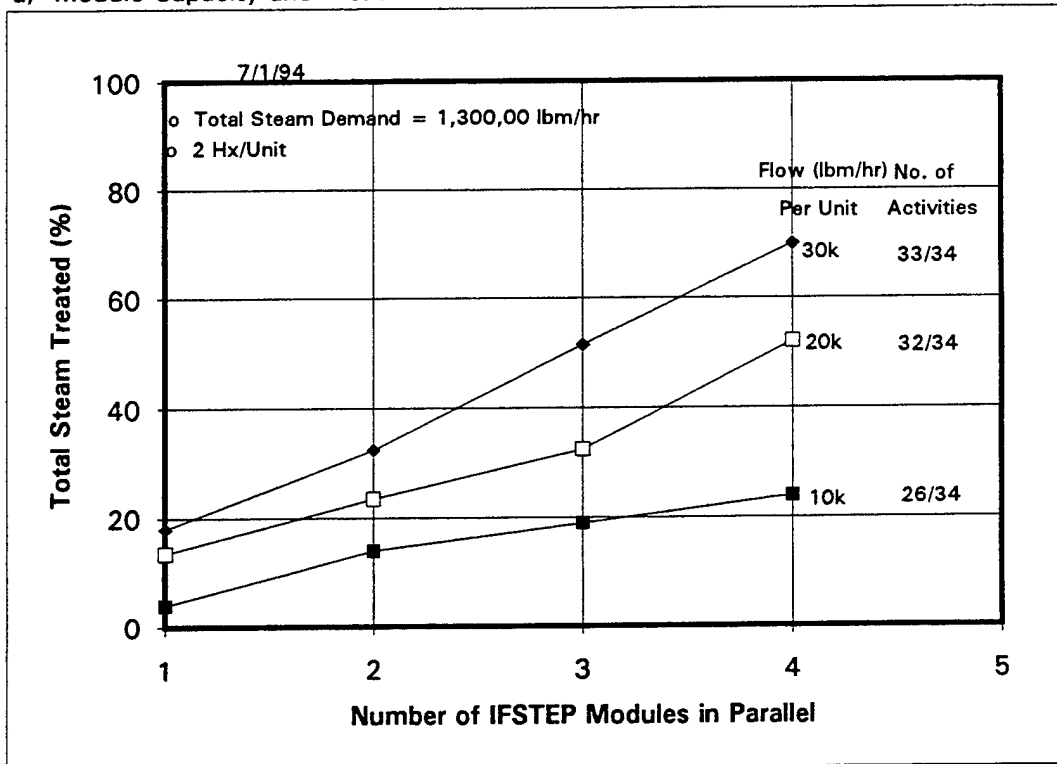

b) Treatment of Total Steam and Module Capacity

Figure 26
Activity coverage with IFSTEP.

DISTRIBUTION LIST

ADMINSUPU / PWO, BAHRAIN, FPO AE
COMFLEACT / PWO, FPO AP
NAS PENSACOLA / PWC, PENSACOLA, FL
NAVAMPHIBBASE LITTLE CREEK / PWD, NORFOLK, VA
NAVSHIPYD / PWD, PEARL HARBOR, HI
NAVSHIPYD / PWO CODE 400, CHARLESTON, SC
NAVSHIPYD / PWO, PHILADELPHIA, PA
NAVSHIPYD / PWO, BREMERTON, WA
NAVSTA / PUGET SOUND, PWO, SEATTLE, WA
NAVSTA / PWD, MAYPORT, FL
NAVWPNSTA / PWO, CONCORD, CA
NAVWPNSTA EARLE / PWD, COLTS NECK, NJ
NETC / PWD, NEWPORT, RI
PWC ALAMEDA / CODE 600, ALAMEDA, CA
PWC BATH / BATH, ME
PWC GAETA / FPO AE
PWC GUAM / FPO AP
PWC HOLY LOCH UK / FPO AE
PWC LA MADDALENA IT / FPO AE
PWC NEW LONDON / NEW LONDON, CT
PWC NEW ORLEANS / NEW ORLEANS, LA
PWC NORFOLK / CODE 600, NORFOLK, VA
PWC OAKLAND / CODE 954, OAKLAND, CA
PWC PASCAGOULA / PASCAGOULA, MS
PWC SAN DIEGO / CO, SAN DIEGO, CA
PWC SUBIC / FPO AP
PWC TREASURE ISLAND / SAN FRANCISCO, CA
PWC YOKOSUKA / FPO AP
PWD CORPUS CHRISTI / CORPUS CHRISTI, TX
PWD GROTON / GROTON, CT
PWD TACOMA / TACOMA, WA
SUBASE / PWO, KINGS BAY, GA