

NAVAL POSTGRADUATE SCHOOL MONTEREY, CALIFORNIA

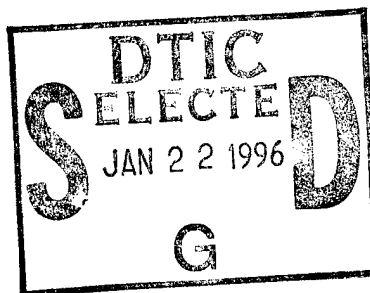

THESIS

LABORATORY EXPERIMENTS FOR COMMUNICATIONS ANALYSIS

by

Shireen M. Cookson

June, 1995

Thesis Advisor:

Randy L. Borchardt

Second Reader:

Tri T. Ha

Approved for public release; distribution is unlimited.

DTIC QUALITY INSPECTED 3

19960118 030

REPORT DOCUMENTATION PAGE

Form Approved OMB No. 0704-0188

Public reporting burden for this collection of information is estimated to average 1 hour per response, including the time for reviewing instruction, searching existing data sources, gathering and maintaining the data needed, and completing and reviewing the collection of information. Send comments regarding this burden estimate or any other aspect of this collection of information, including suggestions for reducing this burden, to Washington Headquarters Services, Directorate for Information Operations and Reports, 1215 Jefferson Davis Highway, Suite 1204, Arlington, VA 22202-4302, and to the Office of Management and Budget, Paperwork Reduction Project (0704-0188) Washington DC 20503.

1. AGENCY USE ONLY <i>(Leave blank)</i>	2. REPORT DATE June, 1995	3. REPORT TYPE AND DATES COVERED Master's Thesis	
4. TITLE AND SUBTITLE LABORATORY EXPERIMENTS FOR COMMUNICATIONS ANALYSIS		5. FUNDING NUMBERS	
6. AUTHOR(S) Shireen M. Cookson		7. PERFORMING ORGANIZATION NAME(S) AND ADDRESS(ES) Naval Postgraduate School Monterey CA 93943-5000	
8. PERFORMING ORGANIZATION REPORT NUMBER		9. SPONSORING/MONITORING AGENCY NAME(S) AND ADDRESS(ES)	
10. SPONSORING/MONITORING AGENCY REPORT NUMBER		11. SUPPLEMENTARY NOTES The views expressed in this thesis are those of the author and do not reflect the official policy or position of the Department of Defense or the U.S. Government.	
12a. DISTRIBUTION/AVAILABILITY STATEMENT Approved for public release; distribution is unlimited.		12b. DISTRIBUTION CODE	
13. ABSTRACT <i>(maximum 200 words)</i> This is a set of five laboratories designed to provide a working knowledge of the subjects covered in a course on the basics of communication theory. There are a wide range of topics covered. The concepts start with spectral analysis of signals and continue with the sampling of those signals. Sampling at and above the Nyquist rate is demonstrated, as well as the inability to reconstruct an undersampled signal. Several signals are generated and analyzed. Modulation is accomplished on single and double-tone frequencies. Frequency-division multiplexed and time-division multiplexed signals are analyzed. Demodulation is accomplished through the use of low pass filters, envelope detectors, an AM radio and a phase locked loop. The equipment required for these laboratories is tabulated and recommendations are provided for implementation. Laboratory manual, data sheets and solutions are also provided.			
14. SUBJECT TERMS Communications, Systems, Laboratories, Modulation		15. NUMBER OF PAGES 134	
		16. PRICE CODE	
17. SECURITY CLASSIFICATION OF REPORT Unclassified	18. SECURITY CLASSIFICATION OF THIS PAGE Unclassified	19. SECURITY CLASSIFICATION OF ABSTRACT Unclassified	20. LIMITATION OF ABSTRACT UL

Approved for public release; distribution is unlimited.

**LABORATORY EXPERIMENTS
FOR COMMUNICATIONS ANALYSIS**

Shireen M. Cookson
B.S., Clarkson University, 1986

Submitted in partial fulfillment
of the requirements for the degree of

MASTER OF SCIENCE IN ELECTRICAL ENGINEERING

from the

NAVAL POSTGRADUATE SCHOOL

June 1995

Author:



Shireen M. Cookson

Approved by:

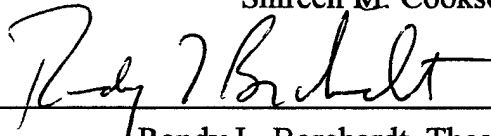

Randy L. Borchardt, Thesis Advisor

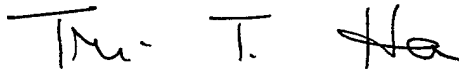

Tri T. Ha, Second Reader

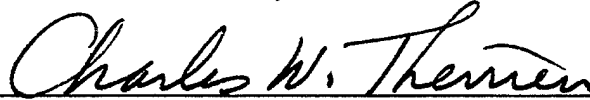

Michael A. Morgan, Chairman
Department of Electrical and Computer Engineering

ABSTRACT

This is a set of five laboratories designed to provide a working knowledge of the subjects covered in a course on the basics of communication theory. There are a wide range of topics covered. The concepts start with spectral analysis of signals and continue with the sampling of those signals. Sampling at and above the Nyquist rate is demonstrated, as well as the inability to reconstruct an undersampled signal. Several signals are generated and analyzed. Modulation is accomplished on single and double-tone frequencies. Frequency-division multiplexed and time-division multiplexed signals are analyzed. Demodulation is accomplished through the use of low pass filters, envelope detectors, an AM radio and a phase locked loop. The equipment required for these laboratories is tabulated and recommendations are provided for implementation. Laboratory manual, data sheets and solutions are also provided.

Accession For	
NTIS CRA&I	<input checked="" type="checkbox"/>
DTIC TAB	<input type="checkbox"/>
Unannounced	<input type="checkbox"/>
Justification	
By	
Distribution /	
Availability Codes	
Dist	Avail and/or Special
A-1	

TABLE OF CONTENTS

I. INTRODUCTION	1
II. LABORATORY DEVELOPMENT NOTES	3
A. LABORATORY DESIGN	3
B. LABORATORY 1: INTRODUCTION TO LABORATORY EQUIPMENT	3
C. LABORATORY 2: SAMPLING AND ANALOG-TO-DIGITAL CONVERSION	4
D. LABORATORY 3: AMPLITUDE AND FREQUENCY MODULATION	5
E. LABORATORY 4: FREQUENCY-DIVISION MULTIPLEXING AND TIME-DIVISION MULTIPLEXING	6
F. LABORATORY 5: PHASE LOCKED LOOP	7
III. LABORATORY EQUIPMENT	9
IV. CONCLUSION	11
APPENDIX A. LABORATORY 1	13
APPENDIX B. LABORATORY 2	33
APPENDIX C. LABORATORY 3	55
APPENDIX D. LABORATORY 4	89
APPENDIX E. LABORATORY 5	105

LIST OF REFERENCES 123

INITIAL DISTRIBUTION LIST 125

I. INTRODUCTION

This document contains the development notes and results for a set of five laboratories designed to provide a working knowledge of the subjects covered in an introductory communications analysis course. Each appendix contains a laboratory document that will guide the student in the completion of each experiment, a data sheet to accompany each lab, a solution guide and an equipment sheet. Each laboratory document references the data sheet by bold face Qs indicating questions that should be answered on the data sheet. This will ensure that all pertinent information required for a formal lab write up will be addressed.

Laboratory 1 provides an introduction to circuit construction and laboratory equipment. This laboratory is designed for the student who has never assembled a circuit in the lab. A summer is built using a $\mu A741$ operational amplifier. The RAPIDS computer system is introduced, as well as the Tektronix 2445B oscilloscope. The RAPIDS system is a system with which most students are not familiar and is required for Laboratories 1, 2, and 3. Using the RAPIDS system, signals are viewed in the time and frequency domains and compared to theoretical predictions. It is also a prelude to Laboratory 3 which utilizes the same circuit.

Laboratory 2 covers sampling, recovery and analog-to-digital conversion. The concepts of natural sampling and Nyquist rate are demonstrated through the use of a LF198A sample and hold integrated circuit. Spectral analysis is performed on each signal. To recover the signal, the sampled signal is passed through a low pass filter (LPF) built by the student. The signal is also quantized and encoded using a printed circuit board designed for lab use in the course EC2220.

Laboratory 3 is an exercise in amplitude and frequency modulation. Amplitude modulated (AM) signals are generated via laboratory equipment and their spectra analyzed. The message signal is detected through an envelope detector and compared to

the original in the frequency and time domains. Two signals are compared by listening to their tones. The procedure is repeated using a double tone created by the summer circuit of laboratory 1. FM signals are generated and analyzed in the time and frequency domains. The HP8656B signal generator is also introduced in this lab.

Laboratory 4 demonstrates the concepts of frequency-division multiplexing (FDM) and time-division multiplexing (TDM). FDM signals are generated via laboratory equipment and the composite signals analyzed in the frequency domain. The HP8590B Spectrum Analyzer is introduced for this purpose. TDM signals are produced by the construction of a circuit that uses a CD4051B CMOS analog multiplexor as a commutation device. The TDM signal is a composite of four signals as viewed on the oscilloscope.

Laboratory 5 completes the assignments with the detection of FM signals using a phase locked loop (PLL). The PLL is wired using a NE565 PLL integrated circuit. The demonstration includes the free running, capture and lock states and concludes with FM demodulation.

The design notes for each laboratory are outlined in the following chapters. A composite list of laboratory equipment required for each station is provided and compared to inventory on hand.

II. LABORATORY DEVELOPMENT NOTES

A. LABORATORY DESIGN

The majority of the development centered around providing adequate setups and circuits that would demonstrate the basic theories and concepts of communications analysis. The laboratories were developed with the following questions in mind:

1. What are the concepts that have been covered and need to be demonstrated at this particular point in the course?
2. What research circuits and/or setups will accomplish the demonstration of these concepts?
3. Are the chosen circuits and/or setups at a level of student understanding?
4. What steps are required to accomplish the laboratory?
5. What questions allow the student to gain insight to the theory from analysis of the laboratory data?
6. Are the setups/circuits reconstructible using the documented steps? Do they adequately demonstrate concepts that require laboratory emphasis?

Each lab, with the exception of Laboratory 3, takes approximately 2-3 hours to complete, depending on the experience of the student. Laboratory 3 takes approximately 4 hours due to the extent of the calculations and the introduction of new equipment. The estimated time was hard to judge since they have not been tested from a student's point of view.

B. LABORATORY 1: INTRODUCTION TO LABORATORY EQUIPMENT

Laboratory 1 was completed last, taking into account the equipment and basic working knowledge required for the rest of the laboratories. The equipment for the first laboratory was included, as well as that common to most. This lab was constructed with

the student who is unfamiliar with circuit construction in mind. For those students who are familiar with circuit construction, completion of this lab will still be beneficial.

A summer circuit is designed using a $\mu A741$ operational amplifier [Ref. 1]. The circuit provides summation of two signals with a gain of two. This circuit provides for the demonstration of basic circuit construction and analysis. Two periodic waveforms are applied as inputs and the output signal is analyzed. The input and output signals are viewed on the RAPIDS oscilloscope and spectrum analyzer screens. Signal periods and amplitudes are measured. The student is able to exercise Fourier series [Ref. 2] and Fourier transform [Ref. 3] techniques and then compare the results to the RAPIDS output. Hard copy plots from the RAPIDS system are generated.

The more conventional Tektronix 2445B oscilloscope is also introduced in an effort to acquaint the student with more common equipment. The displayed signal on the T2445B is compared to that displayed on the RAPIDS system by visualization as well as measurements. This demonstrates the differences in accuracy and friendliness of available equipment.

C. LABORATORY 2: SAMPLING AND ANALOG-TO-DIGITAL CONVERSION

The concepts of sampling, filtering and analog-to-digital (A-D) conversion are explored in Laboratory 2. An LF198 sample and hold chip is used to construct the circuit. The circuit was designed using the National Semiconductor LF198A specifications for a typical 'Output Holds at Average of Sampled Input' application. A logic input is applied as the sample pulse as specified. The circuit is first used to perform natural sampling on a DC signal. A DC signal was chosen so the voltage level could be modified by hand during the sample pulse. When the circuit is not in sample mode, the output is zero, and varying the DC voltage has no effect. A sine wave is then sampled above, at and below Nyquist rate and recovered at each instance using a 60dB/decade lowpass Butterworth filter

(LPF). The LPF was constructed with the following specification, and components to ensure a 60dB rolloff [Ref. 1]:

$$C_3 = .01 \mu\text{f}, \quad C_1 = .5C_3 = .005 \mu\text{f}, \quad C_2 = 2C_3 = .02 \mu\text{f},$$

$$R = \frac{1}{\omega_c C_3} = \frac{1}{2000 \pi (.01)} \approx 16 K\Omega \quad (2.1)$$

The Fourier series and transform are computed for the sampled signal and compared to the RAPIDS displays.

A-D conversion is accomplished through the use of a printed circuit board constructed for the course EC2220: Applied Electronics. This circuit converts the analog signal to a digital signal and displays the quantized output on a series of 16 LEDs. The student constructs the quantizing characteristic plot by measuring the quantization step size. The signal is converted back to analog on the board and compared to the original.

D. LABORATORY 3: AMPLITUDE AND FREQUENCY MODULATION

Lab 3 exercises the generation and detection of AM and FM signals. All signals produced throughout this lab are analyzed in both the frequency and time domains. The student begins by producing an AM signal consisting of a single tone on a carrier. The signal is analyzed at 100%, less than 100% and greater than 100% modulation [Ref. 1].

The message signal is detected by a student-built envelope detector [Ref. 5]. The detected signal is compared to the original. Modulation indices are measured and the effects on the signals spectra and detected output are determined. Double sideband suppressed carrier AM is then generated and detected in the same manner. This signal is then transmitted via a 1.5 MHz carrier and received on an AM radio. The tone of the signal is listened to at

the input, the output of the envelope detector and the radio. Transmission of the signal also incorporates the use of the HP8656B signal generator. Using the summer circuit of laboratory 1, two tones are added to produce a double tone signal. The AM exercise is repeated using the double tone signal.

FM signals are generated using the same equipment as the AM signals. For sine wave and square wave messages, the frequency deviation, bandwidth and modulation indexes are measured and compared with theory. Theoretical Carson's rule calculations are compared to measurements [Ref. 3].

E. LABORATORY 4: FREQUENCY-DIVISION MULTIPLEXING AND TIME-DIVISION MULTIPLEXING

In the FDM portion of this lab, two signals are combined and the HP8590B spectrum analyzer is introduced. Two message signals, both at 10 kHz, are amplitude modulated onto separate carrier frequencies. These signals are then combined. The sidebands are located and measured with respect to their center frequencies. The combined signals are then amplitude modulated onto a carrier frequency. This signal is then analyzed. The result demonstrates that two messages at the same frequency can be transmitted on one carrier and recovered. The concepts of increased signal bandwidth, crosstalk and frequency spacing are also demonstrated. Theoretical calculations for determining the signals components are compared to measured values.

The TDM circuit is constructed using four integrated circuit chips adapted from Ref. [4]. See Figure 2 of Appendix D. A square wave and a triangle wave are produced using a XR8038 precision waveform generator. They are multiplexed with two external inputs, a DC signal and a square wave, using a CD4051B analog multiplexor. The output waveform is a combination of the four signals. Each signal is sampled once every clock pulse. The clock frequency of 7.5 kHz is provided by a CD4029B up/down counter.

Each signal component, as well as the composite wave, are measured for frequency, period and amplitude. The increase in signal bandwidth is also measured.

F. LABORATORY 5: PHASE LOCKED LOOP

The phase locked loop experiment completes the lab sequence. This circuit is constructed using a NE565 PLL integrated circuit based on the National Semiconductor NE/SE565 specifications. An external resistor is determined by the student using the equations provided in the lab. These equations also determine the center, capture and lock frequencies. These frequencies are then measured and compared to those predicted. A sine wave is then applied to the PLL and the capture and lock ranges are exercised by varying the frequency. An FM signal is then generated and applied to the circuit. Demodulated output is monitored and compared to input as the frequency is varied.

III. LABORATORY EQUIPMENT

The equipment required for the completion of all labs is listed in Table 1. It is recommended that each station be set up with all the equipment listed. The total number of each system required is based on 8 lab stations. This number was chosen based on an average class of 16 to 24 students. The components required are listed for stocking purposes in Table 1. In several cases the systems required exceed the stock on hand. This can be resolved by staggering lab times or purchasing more equipment.

Equipment	Required per Team	Total Number Required	In Stock
RAPIDS System	1	8	10
Wavetek 186 Func Generator	2	16	12
Wavetek 142 Func Generator	1	8	12
Wavetek 132 Func Generator	1	8	12
Tektronix DM502A Multimeter	1	8	25
Tektronix PS503 Power Supply	1	8	35
Tektronix 2445B Oscilloscope	1	8	10
HP8656B Signal Generator	1	8	9

HP8590B Signal Generator	1	8	8
Speaker	1	8	10
AM Radio	1	8	1
461A Amplifier	1	8	7
Antenna	1	8	1
NE565 PLL	1	8	> 40
4001 NOR	1	8	> 50
CD4029B Counter	1	8	0
CD4051B Multiplexor	1	8	> 50
XR8038	1	8	0
N4764	1	8	> 40
μ A741 Op Amp	1	8	> 50
LF198A Sample and Hold	1	8	35
LM301	2	16	70
A-D D-A PCB	1	8	30
Breadboard	1	8	30
Resistors and Capacitors	Several	Several	Plenty on hand

Table 1. Equipment Requirements

IV. CONCLUSION

Overall, these laboratories cover several topics and help to build a broad scope of knowledge for the student being introduced to the field of communications. Course syllabi and notes were obtained and compared to the content to ensure no major subjects were missed.

Beginning electrical engineering students will enjoy the opportunity to see circuits in action, rather than building a circuit to analyze it's internal functions. Non-electrical engineering students will find the circuit construction enlightening, although trouble shooting will be difficult without the proper background. All the major topics for an introductory course are covered and will be reinforced by the completion of these laboratories after the material has been introduced. Each laboratory gives the student the opportunity to think about the subject matter, rather than follow a cookbook type of approach.

During the laboratory documentation phase, little knowledge of the subject by the students was assumed. Therefore, each laboratory is self explanatory. Once each laboratory was developed, it was tested. During testing, care was taken to remain objective. Special note was taken to perform each step as written. The laboratories have not been tested in the classroom setting.

APPENDIX A. LABORATORY 1

Lab 1: Introduction to Laboratory Equipment

Objectives: To introduce the student to the laboratory equipment, circuit construction and troubleshooting techniques needed throughout the course.

Equipment:

- (1) Breadboard
- (1) RAPIDS PC and printer
- (1) Tektronix P5S03 power supply
- (1) Tektronix DM502A Digital Multimeter (DMM)
- (1) Wavetek model 132 signal generator
- (1) Wavetek model 186 signal generator
- (1) Tektronix 2445B oscilloscope

Components:

- (1) μ A741 Operational Amplifier
- (1) 20 K Ω resistor
- (3) 10 K Ω resistors

Part 1: Summer circuit construction

a) Locate the vertical and horizontal rows on the breadboard. The longer vertical rows will be your busses. A bus will be used for power supplies and ground. Align the μ A741 operational amplifier integrated circuit so the pins each connect to their own horizontal row. If you are unfamiliar with building circuits, see the lab technician for clarification.

The end of the chip with the semicircular mark is the top. The pins are numbered from the top left. See Figure 1.

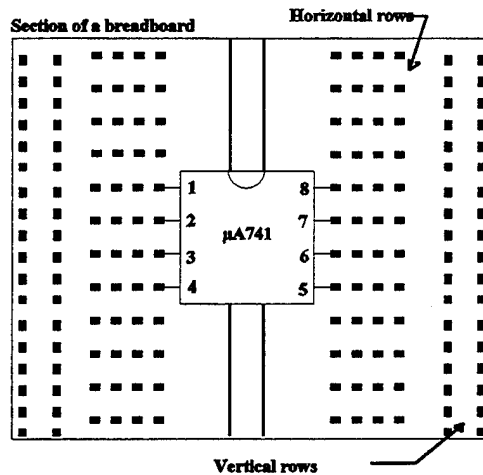

Figure 1

b) Figure 2 is a representation of a summer circuit. This circuit adds the two input signals, denoted A and B, and multiplies them by a gain of two. The pins numbers on the op-amp correspond to the numbers marked in Figure 1. Connect the circuit of Figure 2, disregarding connections to A and B. They will be connected later. Use three horizontal busses. One bus will be for ground, one for + 15 volts and one for - 15 volts. Measure the power **before** it is connected to the circuit! The ± 15 volts and ground will come from the P5S03 power supply. To measure the power, connect the ground and the positive output of the power supply to the DMM. Adjust the power until it reads + 15 volts. Remove the positive lead from the power supply and connect it to the negative output of the P5S03. The DMM should now read negative volts. Adjust the power supply for -15 volts.

Turn off the power supply and connect the ground and the ± 15 volt leads to the circuit.
Leave the power off.

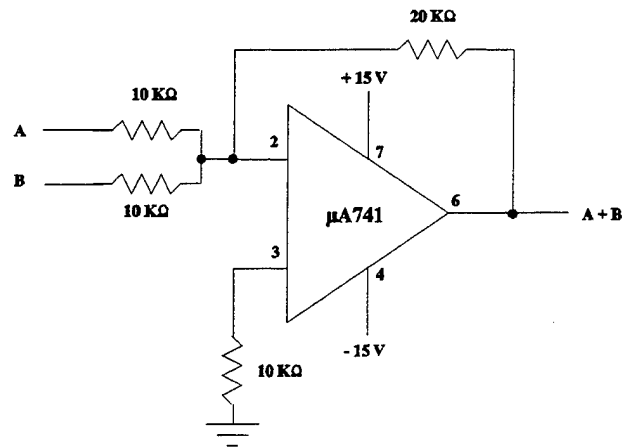

Figure 2

Part 2: Introduction to RAPIDS oscilloscope

a) Turn on the power to the RAPIDS system. Select 'Lab Students' and 'RAPIDS' and hit <return>. You will eventually see a general options screen with choices F1 to F10. Select the oscilloscope (F10). We will change the configuration of the screen using the control options posted at each workstation. Run through the time series menu options to see the effects on the oscilloscope display. Configure the screen as follows:

TIME/DIV: 100 μ s	<CTRL> F2
A = 500mV/div	<CTRL> F3
B = 500mV/div	<CTRL> F4
C = 1 V/div	<CTRL> F5
TRIGGER: Normal	F2

Adjust the Wavetek 186 settings to:
Waveform: sinusoid norm (no offset)
Gen mode: cont
symmetry: norm
atten: -20 dB

Your configuration should now look like Figure 3.

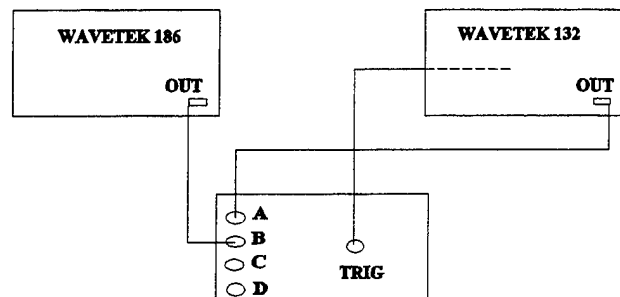

Figure 3

d) Use a T-connector at the outputs of each Wavetek to split the signals. This will enable you to continue to view your signal while applying it to your circuit. These will be your A and B inputs to your summer. Apply the inputs to the summer circuit (order is irrelevant). The BNC cable will have to be split to allow your signal to be applied between input and ground. See the lab technician for help. In the same manner, connect the output of the circuit ($A + B$) to channel C of the RAPIDS system. Vary the frequencies and amplitudes of your input signals to see the effects on the summed output. Return your signals to their original values and print the RAPIDS screen showing the two

inputs on channels A and B, and the output on channel C. Press F8 to label your plot. Press <Shift> PRT SC to plot.

e) To pause the display during acquisition mode, press <return>. Use the up/down arrows to position the marker on the screen to measure the period and amplitude of each signal. The values will be displayed at the bottom of the screen. Make sure you are measuring the correct amplitude by selecting the channel (press A, B or C). **Q:** What is the period, amplitude and calculated frequency of each signal? **Q:** What is the Fourier series and transform of each signal? Press <return> again to reacquire the display. Do not disconnect your setup.

Part 3: Introduction to RAPIDS Spectrum Analyzer and Tektronix 2445B Oscilloscope.

a) Press F9 to view the RAPIDS spectrum analyzer. Run through the control keys displayed at your workstation to see the effects of each on the display. Set up the screen as follows:

INPUT VOLTAGE: 8.0 V pp	<ALT> F8
TRANSLAT FREQ: 0.0 kHz	<ALT> F5
WINDOW TYPE: Rectangular	<ALT> F7
TRIGGER TYPE: Normal	F2
SAMPLE RATE: 50 kHz	<ALT> F2
SPECTRA AVGD: 1	<ALT> F9
MAGNITUDE SCALING: volts	<ALT> F6

Press <ALT> F10 until channel A is displayed. Press <return> to pause the display to measure the spectral frequency(s). Press <return> to reacquire the display. Repeat for channels B and C. **Q:** What are the measured frequency components and their amplitudes for each signal? Press F7 to label the screen and then <shift> PRT SC to print. Provide spectral plots for each signal. **Q:** How do these measurements compare to the theoretical FT's computed in part 2?

b) Turn the power on to the oscilloscope. Remove the channel A connection to the RAPIDS DOP and connect it to channel 1 on the oscilloscope. Set up the oscilloscope as follows:

Vertical display: Vertical mode: Ch 1
 Ch1 volts/div: 500 mv
 Vertical coupling: 50 Ω DC
 Ch1 volts/div variable: fully CW

Horizontal display: Mode: auto
 Time/div: 500 μ s
 Slope: +
 Source: Vert Ch1
 Sec/div variable: fully CW
 Coupling: AC

To measure the amplitude of the signal press Δv and position the cursors. To measure the period of the signal press Δt and position the cursors. To measure the frequency of the signal simultaneously press Δt and Δv and position the cursors. **Q:** What are the measured frequency, period and amplitude of each signal? **Q:** How does this compare

to the measurements taken with the RAPIDS system? Do not disconnect your summer circuit. It will be used for laboratory 3.

Lab 1: Introduction to Laboratory Equipment

Data Sheet

2e) **Q:** Using the RAPIDS oscilloscope, what are the measured period and amplitude as well as the calculated frequency of each signal?

Q: What is the Fourier series and transform of each signal?

3a) **Q:** What are the measured frequency components and their amplitudes for each signal?

Q: How do these measurements compare to the theoretical FT's computed in part 2?

Q: Using the Tektronix 2445B oscilloscope, what are the measured frequency, period and amplitude of each signal?

Q: How does this compare to the measurements taken with the RAPIDS system?

Plot check list

- 4 kHz square wave, 1 kHz sine wave and their sum. (channels A, B, & C)
- Spectrum of sine wave
- Spectrum of square wave
- Spectrum of summed wave

Lab 1: Introduction to Laboratory Equipment

Solutions

2e) Q: Using the RAPIDS oscilloscope, what are the measured period and amplitude as well as the calculated frequency of each signal?

A:

Channel	Amp (mv)	Period (ms)	Freq (KHz)
A (sine)	530	1.06	0.943
B (square)	470	0.250	4.000
C (A + B)	2.06	0.245	4.082

Q: What is the Fourier series and transform of each signal?

A: Sine wave:

$$x(t) = \frac{1}{2} \sin 2 \pi 1000 t$$

$$X(f) = j \frac{1}{2} [\delta(f + 1000) + \delta(f - 1000)]$$

Square wave:

$$x(t) = \frac{4A}{\pi} \left(\sin \omega t + \frac{1}{3} \sin 3 \omega t + \frac{1}{5} \sin 5 \omega t + \dots \right)$$

$$x(t) = \frac{2}{\pi} \left(\sin 2 \pi 4000 t + \frac{1}{3} \sin 2 \pi 12000 t + \frac{1}{5} \sin 2 \pi 20000 t + \dots \right)$$

$$X(f) = j \frac{1}{\pi} \left[\delta(f + 4000) + \delta(f - 4000) + \frac{1}{3} \delta(f + 12000) + \frac{1}{3} \delta(f - 12000) + \right. \\ \left. \frac{1}{5} \delta(f + 20000) + \frac{1}{5} \delta(f - 20000) \right]$$

Sine + Square wave:

$$x(t) = \frac{1}{2} \sin 2 \pi 1000 t + \frac{2}{\pi} \left(\sin 2 \pi 4000 t + \frac{1}{3} \sin 2 \pi 12000 t \right. \\ \left. + \frac{1}{5} \sin 2 \pi 20000 t + \dots \right)$$

$$X(f) = j \frac{1}{2} \left[\delta(f + 1000) + \delta(f - 1000) \right] + j \frac{1}{\pi} \left[\delta(f + 4000) + \delta(f - 4000) \right. \\ \left. + \frac{1}{3} \delta(f + 12000) + \frac{1}{3} \delta(f - 12000) + \frac{1}{5} \delta(f + 20000) + \frac{1}{5} \delta(f - 20000) \right]$$

3a) **Q:** What are the measured frequency components and their amplitudes for each signal?

A:

Channel	Amp (mv)	Freq (KHz)
A (sine)	0.394	0.976
B (square)		
1st harmonic	0.402	4.052
2nd harmonic	0.171	12.10
3rd harmonic	0.104	20.16
C (A+B)		
1st harmonic	0.659	0.976
2nd harmonic	0.171	4.052
3rd harmonic	0.104	12.10
4th harmonic	0.209	

Q: How do these measurements compare to the theoretical FT's computed in part 2?

A: The sine wave amplitude is off, but the frequency is quite close to 1 KHz. The square and summed wave's fundamental amplitude is off but the amplitude of the additional harmonics are correct with respect to the fundamental.

Q: Using the tektronix 2445B oscilloscope, what are the measured frequency, period and amplitude of each signal?

A:

Channel	Amp (mv)	Period (μ s)	Freq (KHz)
A (sine)	0.60	1.067	0.938
B (square)	0.56	0.249	4.020
C (A + B)	2.16	0.248	4.090

Q: How does this compare to the measurements taken with the RAPIDS system?

A: The RAPIDS system is not as accurate as the Tektronix oscilloscope. The summed wave is much easier to read on the RAPIDS system.

The following plots are attached in order:

Plot 1: 4 KHz square wave, 1 KHz sine wave and their sum. (channels A, B, & C)

Plot 2: Spectrum of sine wave

Plot 3: Spectrum of square wave

Plot 4: Spectrum of summed wave

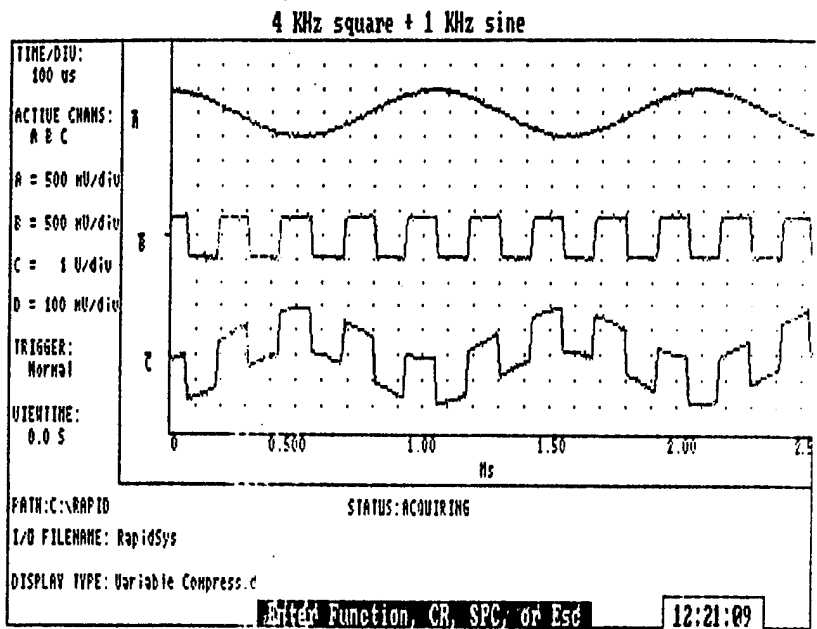

Plot 1

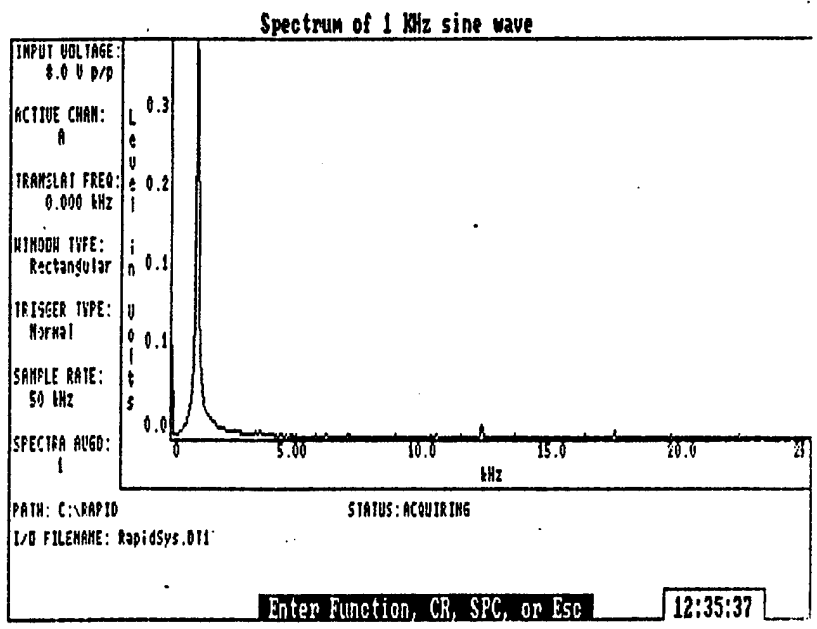

Plot 2

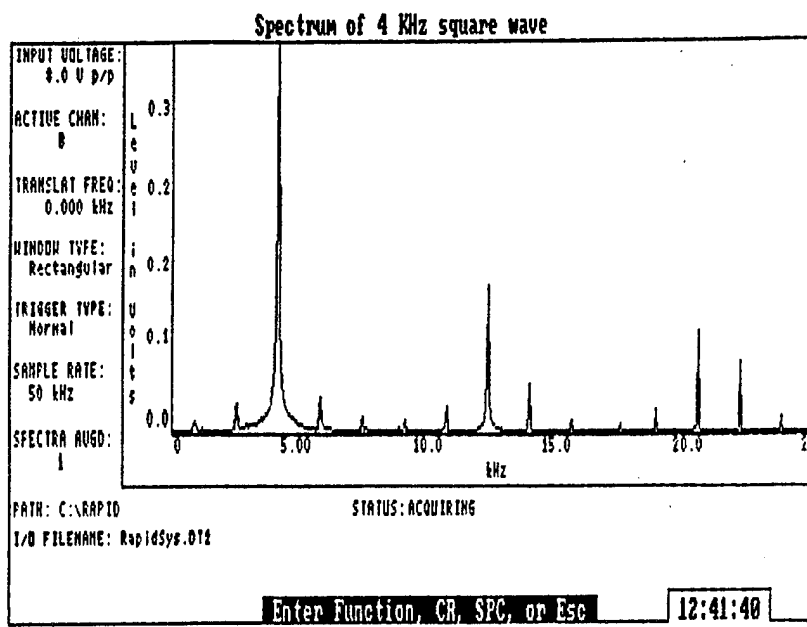

Plot 3

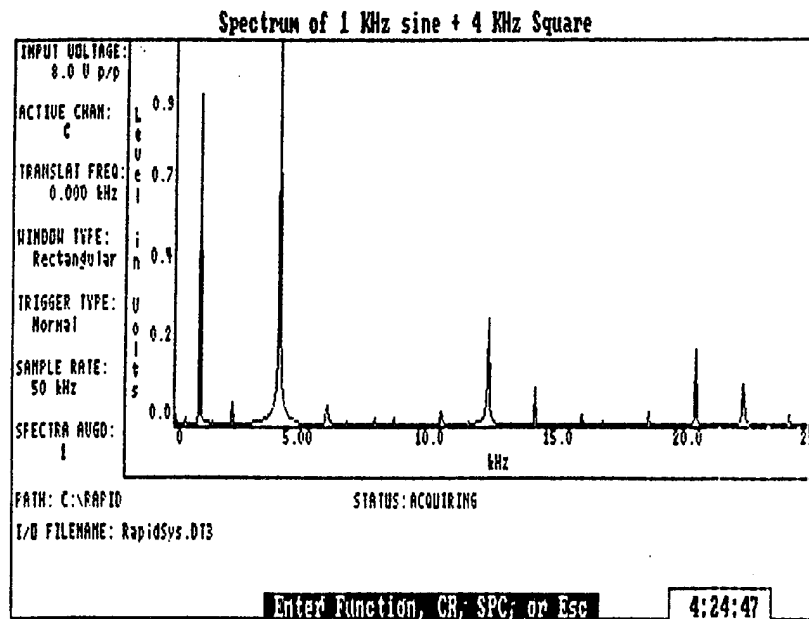

Plot 4

LAB 1 Equipment List

Equipment	Required/Team	On/Hand
Wavetek 132	1	24
RAPIDS station	1	10
Tektronix DM502A	1	25
Tektronix PS503	1	35
1 Wavetek 186	1	12

The number of teams is limited to 12, the number of Wavetek 186's available..

Components	Required/Team	On/Hand
Breadboard	1	30
μ A741 Op Amp	1	>50
Resistors/Capacitors - plenty available		

APPENDIX B. LABORATORY 2

Lab 2: Sampling and Analog to Digital Conversion

Objectives: To explore the sampling and quantization processes. To build and demonstrate the characteristics of a low pass filter. To explore the Analog-to-Digital (A-D) and Digital-to-Analog (D-A) conversion techniques. To analyze the spectra of several signals.

Equipment:

- (1) Breadboard
- (1) Wavetek models 132 and 142 signal generators
- (2) Tektronix P5S03 power supplies
- (1) RAPIDS PC and printer
- (1) Tektronix DM502A Digital Multimeter (DMM)

Components:

- (1) LF198A Sample and Hold Chip
- (2) LM301 Operational Amplifiers
- (1) 30 K Ω resistor
- (6) 16 K Ω resistors
- (2) 30 pf capacitors
- (1) .01 μ f capacitors
- (1) .02 μ f capacitors
- (1) .005 μ f capacitors
- (1) Prewired circuit board for A-D and D-A conversion

Part1: Sample and Hold, LPF and Spectral Analysis

a) Construct the circuit of Figure 1. You will need to connect a ground bus, a + 15 volt bus and a - 15 volt bus on your bread board from the power supply. The ± 15 volt busses will provide power to your chips. When the circuit is fully connected, measure the ± 15 volts on the DMM **before** connecting them to the breadboard. Turn the power supply off. Connect your ground and power. Turn the supply back on.

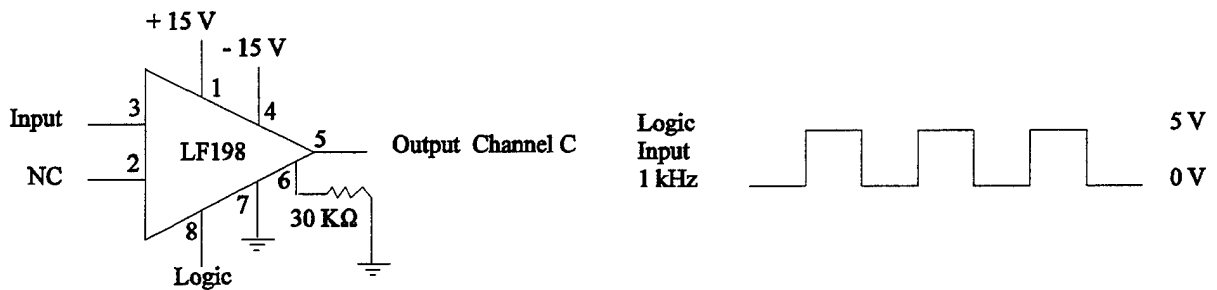

Figure 1

b) Start the RAPIDS system on the PC as done in Lab 1. Bring the oscilloscope screen up and configure it as follows:

TIME/DIV: 100 μ s

A = 5 V/div

B = 5 V/div

C = 2 V/div

D = 2 V/div

TRIGGER: Normal

VIEWTIME: 0.0s

DISPLAY TYPE: Variable Full Scale

c) Set up the Wavetek 142 to produce a 1kHz square wave that varies between 0 and +5 volts (to raise the upper voltage, adjust the attenuation and the vernier). Verify the square wave characteristics by connecting the Wavetek output to DOP channel A. Using a splitter, send the square wave to the logic input of the Sample and Hold chip (pin 8), as well as channel A. This signal is your sample pulse. Connect the output of the sample and hold chip to channel C on the RAPIDS system.

d) Connect the DMM to a free power supply and verify that you can manually adjust the output between 0 and 10 volts. Turn the output down to zero volts and connect to the input of the Sample and Hold chip (pin 3) while maintaining your visual display on the DMM. This is your DC input.

e) Vary the DC input between 0 and 10 volts. **Q:** You will not be able to make sense of the output, why not? What is the sample period and the sample pulse duration? Lower the sampling frequency to .1 Hz. Vary your DC value. Sketch the output. **Q:** What is happening? What kind of sampling is this?

f) Using a Wavetek 132, connect $5\sin 2\pi 1000t$ to DOP channel B. **Q:** What is the Nyquist rate of this signal? Disconnect the DC input and connect the sinusoid. Vary the sample pulse frequency and print plots of channels A, B and C (on one plot) for frequencies below, at and above the Nyquist rate. **Q:** Attach plots and comment on results.

Change the sample rate to 5000 Hz. Q: Calculate the first four harmonic's amplitude and frequencies for the sample pulse and the sampled output ($f_s = 5000$ Hz and $f_m = 1000$ Hz).

g) Turn off all power. Construct the LPF circuit of Figure 2 on the same breadboard. Connect the output (pin 6 on op amp 2) to channel D. Connect the output of the sample and hold to the input of the LPF (pin 3 on op amp 1). Turn the power on. Set the sample pulse at a frequency of 5 kHz. The LPF output should look like a filtered version of the input.

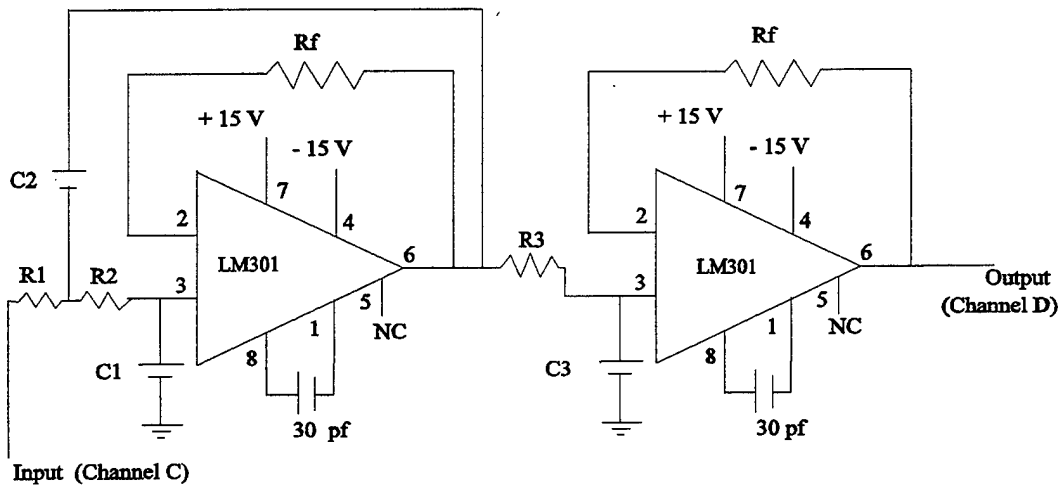

Figure 2 Lowpass Butterworth Filter

$$R_1 = R_2 = R_3 = 16 \text{ K}\Omega, R_f = 32 \text{ K}\Omega, C_1 = .005 \mu\text{f}, C_2 = .02 \mu\text{f}, C_3 = .01 \mu\text{f}$$

h) Plot the spectrum of all 4 channels using the RAPIDS spectrum analyzer. Make sure

the spectra averaged equals eight. You may want to plot both dB scale and volts scale to make measurements easier. Label the baseband frequency and spectra components (freq and amp) **Q:** How do these compare to the calculated results in part 1f? Vary the frequency of the input while viewing the spectrum of the output of the LPF. **Q:** Does this behave as expected? **Q:** What is the cutoff frequency of the LPF?

Part 2: D-A and A-D

a) The D-A and A-D circuits have been pre-wired for you. Obtain a sketch of this circuit from the lab technicians. Make the appropriate ± 15 volt and 5 volt connections.

Connect a DC input to the board and the DMM, as was done in part 1a. Connect the analog out to a second DMM ensuring 0.001 accuracy. Using a Wavetek 132, connect a 0 to 5 volt, 10 kHz sine wave to the sample input.

b) Vary the voltage in, monitor the analog out. The output should closely follow the input but be opposite in sign. Verify that the digital output is representative of the input.

Q: Calculate the quantization step size for this signal (0 to 10 volt analog input converted to an eight bit digital output). **Q:** Measure the quantization step size and compare with your calculations. **Q:** Draw a quantizing characteristic plot for the first three bits.

c) Apply the a $5\sin 2\pi 1000t$ signal to the analog input and view it on the RAPIDS oscilloscope. Connect the analog output to a different channel on the oscilloscope. **Q:** What is happening at the output? What happens when you vary the frequency?

Lab 2: Sampling and Analog to Digital Conversion

Data Sheet

1e) Q: You will not be able to make sense of the output, why not? What is the sample period and the sample pulse duration?

Q: What happens when you vary the DC signal? What kind of sampling is this?

1f) Q: What is the Nyquist rate of $5 \sin 2\pi 1000t$?

Q: Attach plots and comment on results.

Q: Determine the first 4 harmonics (amplitude and frequency) for the sample pulse and the sampled output (for $f_s=5000$ and $f_m=1000$).

A: Sample Pulse :

Calculations:

	Amp	Freq
1st harmonic:		
2nd harmonic:		
3rd harmonic:		
4th harmonic:		

Sampled Signal :

Calculations:

	Amp	LSB	USB
1st harmonic:			
2nd harmonic:			
3rd harmonic:			
4th harmonic:			

1h) Q: How do the plotted spectra components compare to the calculated results in part 1f?

Q: Does varying the frequency change the spectra output as expected?

Q: What is the 3dB down point of the LPF?

2b) Q: Calculate the quantization step size for this signal (a 0 to 10 volt analog input converted to an eight bit digital output).

Q: Measure the quantization step size and compare with your calculations.

Q: Draw a quantizing characteristic plot for the first 3 bits.

2c) Q: What is happening at the output? What happens as the sample pulse frequency is varied?

Plot check list

- Input, sample pulse and sampled output at Nyquist rate
- Input, sample pulse and sampled output below Nyquist rate
- Input, sample pulse and sampled output above Nyquist rate
- Input, sample pulse and sampled output and LPF output
- Spectrum of 5 kHz sample pulse (volts)
- Spectrum of 5 kHz sample pulse (dB)
- Spectrum of sampled signal (dB)
- Spectrum of 1 kHz input
- Spectrum of sampled signal (volts)

Lab 2: Sampling and Analog to Digital Conversion

Solutions

1e) Q: You will not be able to make sense of the output, why not? What is the sample period and the sample pulse duration?

A: The sample pulses are too short to see a response. The sample period, $T = 1$ Hz. The duty cycle, $d=0.5$. The pulse duration, $\tau = dT=(.5)(1)=.5$ secs.

Q: What happens when you vary the DC signal? What kind of sampling is this?

A: The DC value can only be varied during the actual pulse of the sample signal. At zero volts (sample pulse) the output is not sampled. This is natural sampling.

1f) Q: What is the Nyquist rate of $5 \sin 2\pi(1000)t$?

A: $f_s = 2f_o = 2000$ Hz

Q: Attach plots and comment on results.

A: The plots are attached. Below the Nyquist rate, the shape of the signal is unidentifiable. The signal is aliased. At the Nyquist rate, the shape of the signal becomes apparent. Above the Nyquist rate, the shape of the signal becomes more obvious as the sampling frequencies get higher.

Q: Determine the first 4 harmonics (amplitude and frequency) for the sample pulse and the sampled output (for $f_s=5000$ and $f_m=1000$).

A: Sample Pulse :

$$f_s = 5000 \text{ Hz}, T = 1/f = 0.0002 \text{ sec}, \tau = (0.0002)(.5) = 0.0001, A = 2.5 \text{ V}$$

Using the equation for a square wave:

$$V = 4 \frac{A}{\pi} \left(\sin \omega t + \frac{1}{3} \sin 3 \omega t + \frac{1}{5} \sin 5 \omega t + \frac{1}{7} \sin 7 \omega t \right)$$

	Amp	Freq
1st harmonic:	1.593	5000
2nd harmonic:	.5300	15000
3rd harmonic:	.1777	25000
4th harmonic:	.0590	35000

Sampled Signal :

$$f_s = Nf_o, N = \text{samples/cycle} = 5000/1000 = 5, f_o = 1000 \text{ Hz}, T = 1/f_o = 0.001 \text{ sec},$$

$$A_m = 5 \text{ V}, A_p = 5 \text{ V}, n = \text{harmonic \#} = 1, 2, 3, 4$$

Using the equation for a naturally sampled sine wave:

$$S(f) = \frac{TA_m A_p N f_o}{2} \Sigma \text{sinc}(nTNf_o) [\delta[f - f_o(1 + nN)] + \delta[f + f_o(1 - nN)]]$$

	Amp	LSB	USB
1st harmonic:	1.07	4000	6000
2nd harmonic:	.5185	9000	11000
3rd harmonic:	.4859	14000	16000
4th harmonic:	.4424	21000	23000

1h) Q: How do the plotted spectra components compare to the calculated results in part 1f?

A: Plots are attached. The frequencies and amplitudes were close to those calculated in 1f. They may be slightly off because the amplitude of the message signal and the sample pulse may not be exactly 5 (hard to read on Rapids screen). Only the odd frequencies are present.

Q: Does varying the frequency change the spectra output as expected?

A: Yes, as the frequency changes we can watch the spectra components move accordingly.

Q: What is the cutoff frequency of the LPF?

A: 1.074 Hz

2b) Q: Calculate the quantization step size for this signal (0 to 10 volt analog input converted to an eight bit digital output).

A: The resolution for 8 bit quantizing is $2^8 = 256$.

$$00000000 = 0\text{v}, 11111111 = 10\text{v}, V_{\text{full scale}} = 9.97 \text{ v}$$

$$Q_{\text{step size}} = V_{\text{FS}} / (2^n - 1) = 9.97 / (256 - 1) = .039 \text{ v}$$

Q: Measure the quantization step size and compare with your calculations.

A: By measuring the voltage required to change one bit we can tell the quantization step size is .03 volts.

Q: Draw a quantizing characteristic plot for the first 3 bits.

A:

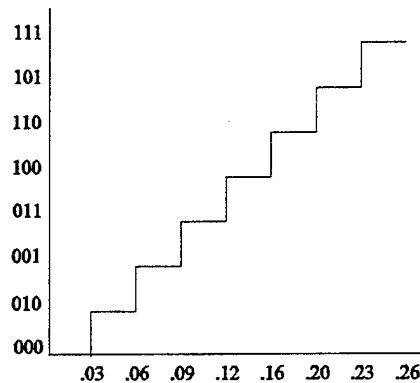

2c) Q: What is happening at the output? What happens as the sample pulse frequency is varied?

A: The output is unipolar. Increasing the sample frequency creates a smoother analog output.

The attached plots are listed below, in order:

- Plot 1: Input, sample pulse and sampled output at Nyquist rate
- Plot 2: Input, sample pulse and sampled output below Nyquist rate
- Plot 3: Input, sample pulse and sampled output above Nyquist rate
- Plot 4: Input, sample pulse and sampled output and LPF output
- Plot 5: Spectrum of 5 kHz sample pulse (volts)
- Plot 6: Spectrum of 5 kHz sample pulse (dB)
- Plot 7: Spectrum of sampled signal (dB)
- Plot 8: Spectrum of 1 kHz input
- Plot 9: Spectrum of sampled signal (volts)

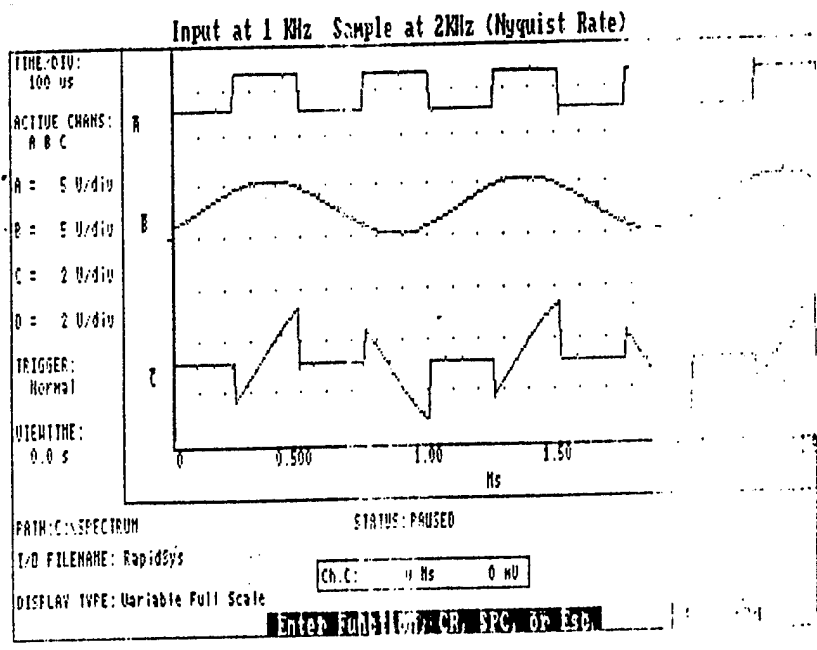

Plot 1

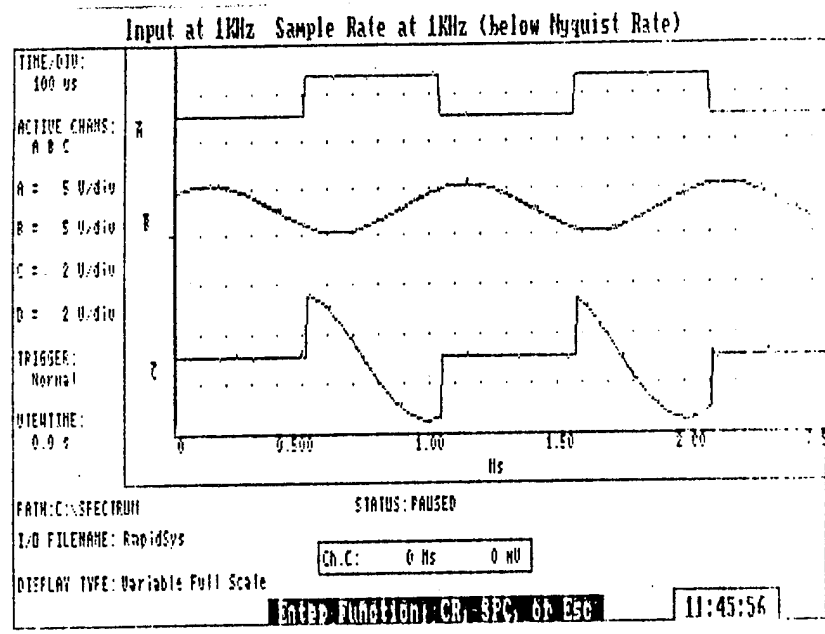

Plot 2

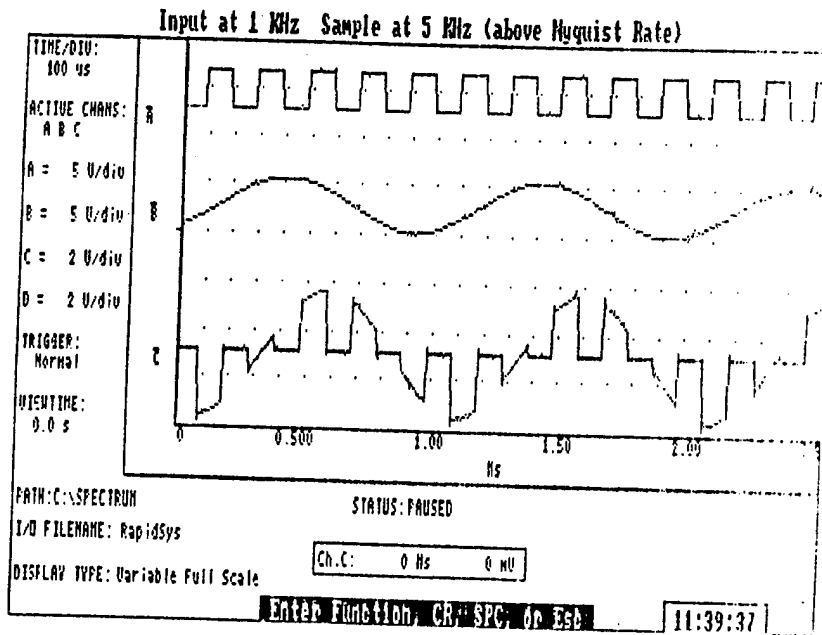

Plot 3

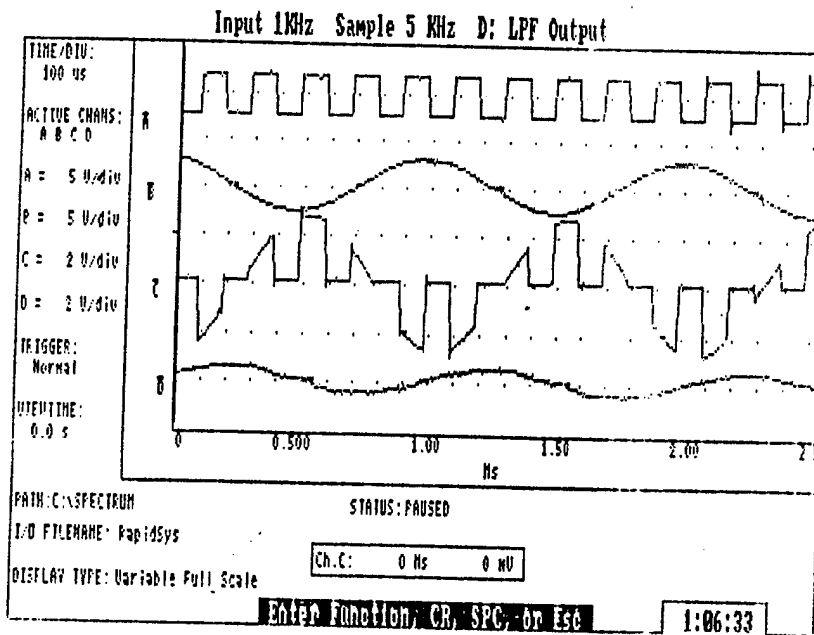

Plot 4

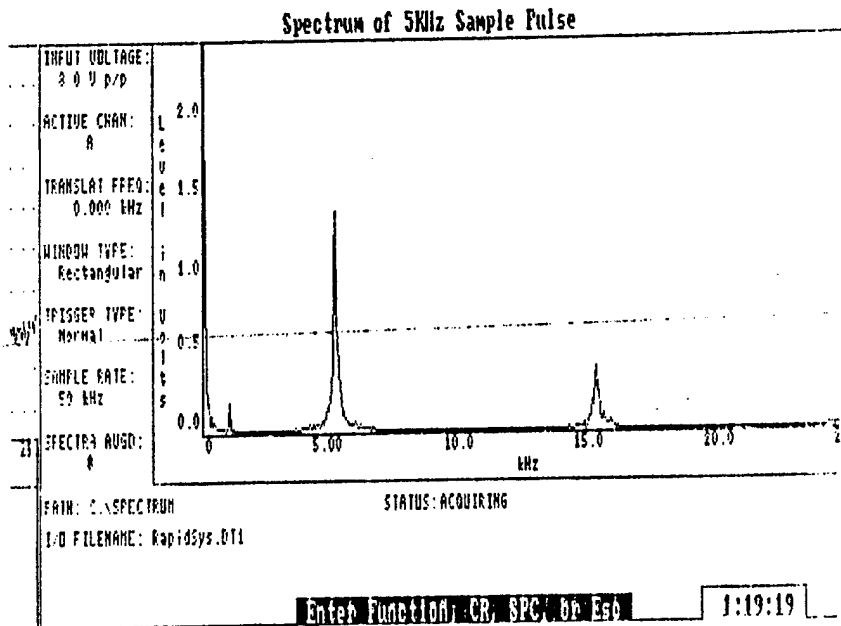

Plot 5

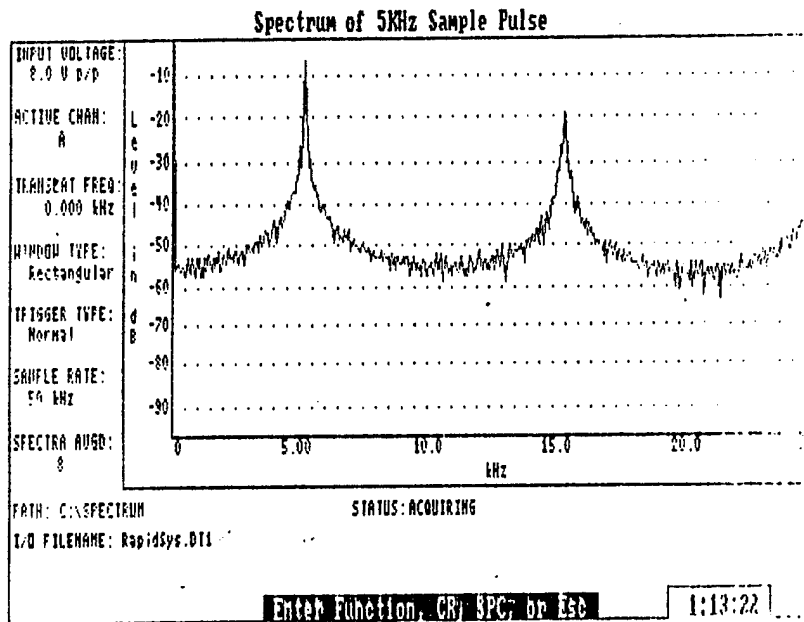

Plot 6

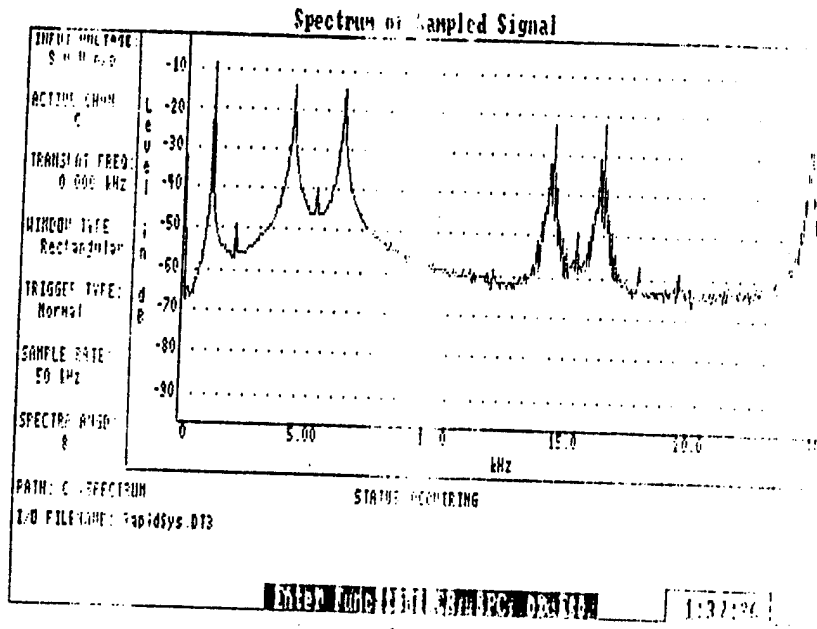

Plot 7

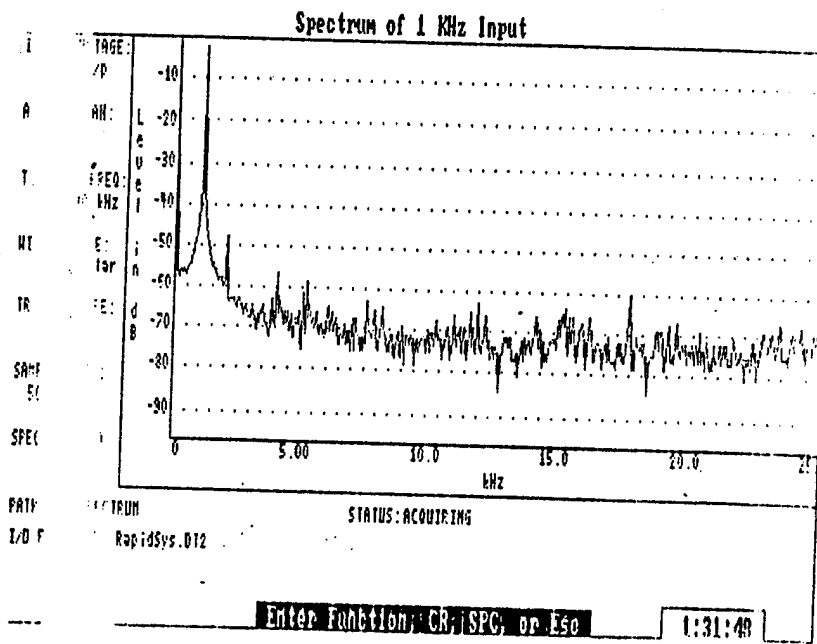

Plot 8

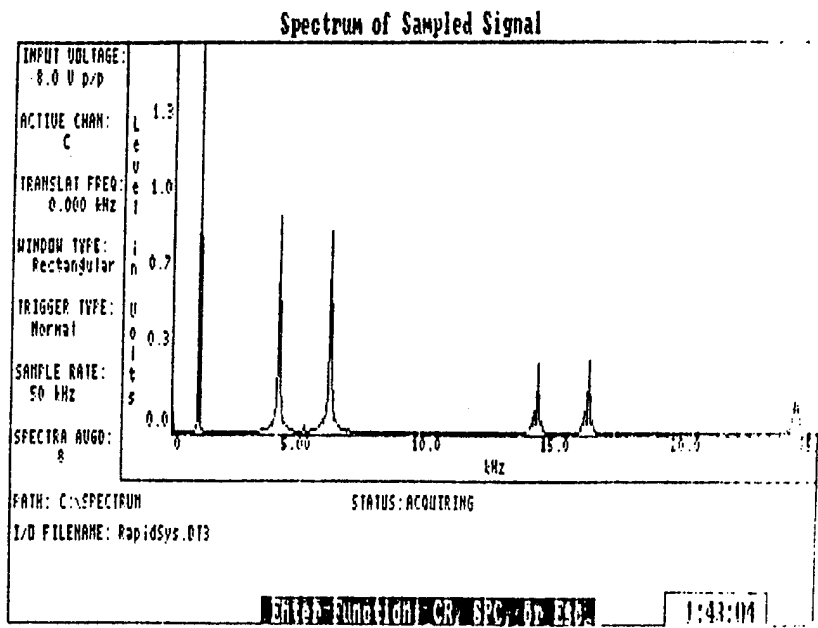

Plot 9

LAB 2 Equipment List

Based on 25 student class, 2-3 persons/team.

Equipment	Required/Team	On/Hand
Breadboard	1	30
Wavetek 132	1	12
Wavetek 142	1	12
RAPIDS station	1	10
Tektronix DM502A	2	25
Tektronix PS503	1	35

The number per team depend upon the RAPIDS system availability. Right now there are only 10 PC's setup in the lab. More PC's could be added with the proper software loaded but more interface hardware would have to be purchased. Recommend either limiting teams to 10 or staggering lab times.

Components	Required/Team	On/Hand
LF198A (Samp & Hold)	1	35
LM301	2	70
Prewired A-D, D-A	1	30
Resistors/Capacitors - plenty available		

Plenty of components on hand for 10-15 teams.

APPENDIX C. LABORATORY 3

Lab 3: Amplitude and Frequency Modulation

Objective: To generate AM and FM signals and observe their spectra. To detect, transmit and receive AM signals.

Equipment:

- (1) Breadboard
- (2) Wavetek model 132 signal generator
- (1) Tektronix P5S03 power supply
- (1) RAPIDS PC and printer
- (1) Tektronix DM502A Digital Multimeter (DMM)
- (1) Wavetek model 186 signal generator
- (1) speaker
- (1) HP 8656B signal generator
- (1) AM radio
- (1) 461A amplifier
- (1) Antenna

Components:

- (1) N4764 Diode
- (1) μ A741 Operational Amplifier
- (1) 20 K Ω resistor
- (4) 10 K Ω resistors
- (1) .01 μ f capacitors

Part1: Amplitude Modulation (AM) Generation and Detection

a) Turn on the power to the RAPIDS system and configure it as follows:

TIME/DIV: 100 μ s

A = 500mV/div

B = 500mV/div

TRIGGER: Normal

VIEWTIME: 0.0s

DISPLAY TYPE: Variable Compressed

b) Connect the Wavetek 132 to DOP channel A and configure it to produce a 1 V peak-to-peak (pp), 1kHz square wave. Ensure there is no DC offset by adjusting the DC offset switch on the back of the Wavetek 132. This will be your message signal. Connect the output of the Wavetek 186 to channel B and configure it to produce a 2 V pp, 20 kHz sine wave. This is your carrier signal. Adjust the Wavetek 186 to the following settings:

Waveform: sinusoid norm

Gen mode: cont

symmetry: norm (no offset)

atten: 0 dB

c) Split the message signal at the Wavetek 132 so the output connects to channel A and VCA IN on the Wavetek 186. Your configuration should now look like Figure 1.

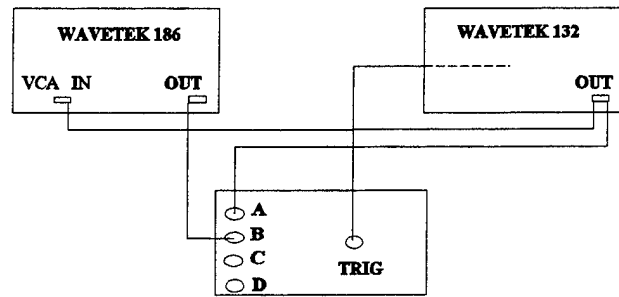

Figure 1

d) Channel B is now a conventional AM signal. Adjust the attenuation variable knob on the 186 to produce AM signals that are 100%, <100% and >100% modulated. The modulation index can be determined from:

$$\% m = k_a \times 100 = \frac{A_{\max} - A_{\min}}{A_{\max} + A_{\min}} \times 100$$

Print a plot of the 100% modulated wave. Q: Compute and draw the spectra of the square wave input and the AM wave. Include the time and frequency representations of each. Using the RAPIDS spectrum analyzer, print the spectra of both channels to verify your results. Configure the spectrum analyzer as follows:

INPUT VOLTAGE: 8.0 V pp
 TRANSLAT FREQ: 0.0 kHz
 WINDOW TYPE: Rectangular
 TRIGGER TYPE: Normal

SAMPLE RATE: 50 kHz

SPECTRA AVGD: 1

MAGNITUDE SCALING: volts

e) Change the signal output of the Wavetek 132 to a sine wave. Construct the envelope detector shown in Figure 2.

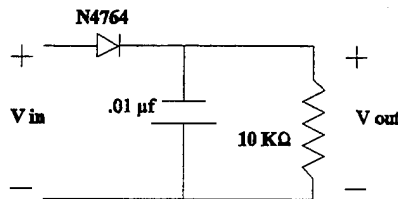

Figure 2

Split the AM signal output (from the Wavetek 186) and apply it the input of the envelope detector. Read the voltage across the $20 K\Omega$ resistor and send this signal to DOP channel C. Channel C is the demodulated signal. Compare this to the input signal. Adjust the variable attenuation on the Wavetek 186 for 100%, <100% and >100% modulation obtaining plots for each case. **Q:** Using the crosshairs on the RAPIDS system, measure the modulation index for each case. How does this effect the output of the envelope detector? **Q:** Compute and draw the spectra of the modulated sine wave. View and plot the spectrum of the AM signal at each instance. **Q:** What effect does the modulation index have on the spectra of each signal?

f) Viewing the AM signal (channel B) on the spectrum analyzer, adjust the variable attenuation on the carrier (Wavetek 186) until the carrier is suppressed. View the signal on the oscilloscope. Notice the phase reversals at the zero crossings of the message signal. If necessary, turn down the frequency to view this, but return it to 1 kHz when complete. This is a double sideband suppressed carrier (DSBSC) signal. Look at the detected message. **Q:** You will have to adjust the plot scale for the detected signal (channel C), why? Plot the message, carrier and detected message. **Q:** At what modulation index does DSBSC occur? **Q:** What is the time and frequency representations of the DSBSC signal? **Q:** What is the average power? **Q:** If the output of the envelope detector was passed through a BPF centered at 21 kHz, what type of output would we see? Sketch the output. What would the frequency representation be? What would the power be? Change the input to a square wave just for fun.

Part 2: AM Transmission and Detection

a) Turn on the power to the HP8656B signal generator. On the center, bottom row, press RF OFF until the far right display is blank indicating zero transmission. Change the output of the Wavetek 132 to a 500 Hz, 2 V pp sine wave (set attenuation at zero). Verify this on the oscilloscope channel A. Disconnect the connection to channel A and apply it to your bread board. Connect it between a vacant row and ground. Connect the negative side of the speaker to ground and the positive side to the same row as the sine wave. Check the polarities on the back of the speaker. The wire colors do not necessarily indicate polarity. Listen to the tone. Move the positive lead of the speaker to the output of the envelope detector. **Q:** How do the tones differ? What does this tell you about the quality of this detector?

b) Split the input to the Wavetek 186 so the signal off the Wavetek 132 also goes to the HP8656B signal generator input, you will directly modulate this signal onto a 1.5 MHz carrier. Connect the RF out of the HP8656B to the HP461A amplifier input. Set the amplifier on 20dB. Connect the output of the amplifier to the antenna. Plug in the radio. Verify your setup with Figure 3. Note that we are modulating our sine wave onto the 20 kHz carrier at the Wavetek 186 and separately modulating it onto a 1.5 MHz carrier at the HP8656B for comparison purposes.

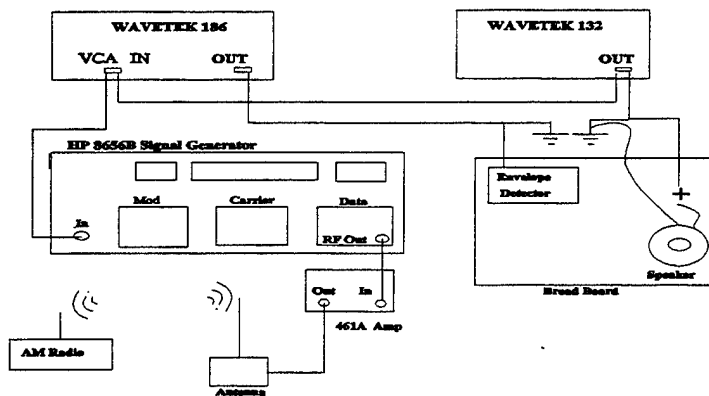

Figure 3

The front of the HP8656B has 3 key pads marked modulation, carrier and data. On the modulation pad, press FM, press OFF, and then press AM. Using the up/down arrow keys below the AM button, adjust the modulation to 20%. On the carrier pad press FREQ. Using the data pad type in 1.5 Mhz. Press RF ON. The display on the far right should read -7.0 dB. If it does not, press AMPTD on carrier pad and adjust it by using the up/down arrow keys below the AMPTD button. Tune the AM radio to pick up the

frequencies we are transmitting. **Q:** What are these frequencies? Sketch the impulses. Once you hear the tone on the radio, vary the message frequency to hear the tone differences. Alternate your speaker between the input signal and the detector output. **Q:** Compare these tones with that emitting from the radio.

c) Construct the summer circuit used in Lab 1. Using a second Wavetek 132 apply a 3 kHz signal to one input and apply the 1 kHz signal from the original Wavetek 132 to the second input. Using your positive speaker connection as a probe, listen to both inputs and the output of the summer. You should hear a double tone. Adjust the frequencies so the tones are distinct. On the HP8656B, turn off the RF. Connect the output of the summer to the HP8656B input and transmit this signal to the AM radio. **Q:** Compare the tones heard on the radio to the original.

Part 3: Frequency Modulation

a) Setup the configuration in Figure 4.

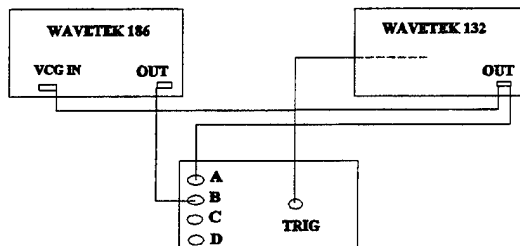

Figure 4

As before, the Wavetek 132 is the message signal. Set up the Wavetek 132 to produce a 1 V pp, 1kHz square wave, with the attenuation set to -20 dB. The Wavetek 186 is the carrier signal. Set the attenuation to -20dB and change the frequency to 10 kHz.

b) Demonstrate the fundamental characteristic of an FM wave, the frequency deviation (maximum departure from the carrier frequency) is directly proportional to the amplitude of the modulating wave. **Q:** What is the time domain representation of this wave? View the spectrum of the FM wave. Adjust the attenuation on the 132 until the carrier is nulled. Print the oscilloscope and spectrum analyzer displays. **Q:** In the time domain, find positive frequency deviation (f^+) and the negative frequency deviation (f^-) using the crosshairs of the oscilloscope. What is the peak frequency deviation? What is the modulation index (β)? Measure $2\Delta f$ on the spectrum analyzer for this value of β ? **Q:** Using Carsons rule, what is the bandwidth for this signal? **Q:** Switch the message signal to a sine wave. **Q:** What is the frequency representation of the FM sine wave? **Q:** Measure f^+ , f^- and $2\Delta f$. What is the frequency deviation, β and the bandwidth? We will demodulate a FM signal in laboratory 5.

Lab 3: Amplitude and Frequency Modulation

Data Sheet

1d) **Q:** Compute and draw the spectra of the square wave input and the AM wave. Include the time and frequency representations of each.

Q: Using the crosshairs on the Rapids system, measure the modulation index for each case (100%, <100%, >100% modulation). How does this effect the output of the envelope detector?

Q: Compute and draw the spectra of the modulated sine wave.

Q: What effect does the modulation index have on the spectra of each signal?

1f) **Q:** You will have to adjust the plot scale for the detected signal (channel C), why?

Q: At what modulation index does DSBSC occur?

Q: What are the time and frequency representations of the DSBSC signal?

Q: What is the power of the DSBSC signal?

Q: If the output of the envelope detector was passed through a BPF centered at 21 kHz, what type of output would we see? Sketch the output. What would the frequency representation be? What would the power be?

2a) **Q:** How do the tones differ? What does this tell you about the quality of this detector?

2b). **Q:** What are the frequencies being transmitted?

Q: Compare these tones with that emitting from the radio.

2c) **Q:** Compare the tones heard on the radio to the original.

Q: What is the time domain complex envelope of this wave?

Q: What are f^+ and f^- . What is the frequency deviation? What is the modulation index (β)? Measure $2\Delta f$ on the spectrum analyzer for this value of β ?

Q: Using Carsons rule, what is the bandwidth for this signal?

Q: What is the frequency representation for the FM sine wave?

Q: Measure f^+ , f^- , and $2\Delta f$. What is the frequency deviation, β and the bandwidth?

Plot check list

- Square wave and 100% AM square wave
- Square wave spectrum
- 100% modulated square wave spectrum
- Sine wave, <100% modulated sine wave and detected sine wave
- Spectrum of <100% modulated sine wave
- Sine wave, =100% modulated sine wave and detected sine wave
- Spectrum of =100% modulated sine wave
- Sine wave, >100% modulated sine wave and detected sine wave
- Spectrum of >100% modulated sine wave
- Sine wave, AM DSBSC wave and detected sine wave
- Spectrum of AM DSBSC wave
- Square wave and FM square wave
- Spectrum of FM square wave
- Sine wave and FM sine wave
- Spectrum of FM sine wave

Lab 3: Amplitude and Frequency Modulation

Solutions

1d) Q: Compute and draw the spectra of the square wave input and the AM wave.

A: Square wave:

$$m(t) = \frac{4A}{\pi} \left(\sin \omega t + \frac{1}{3} \sin 3 \omega t + \frac{1}{5} \sin 5 \omega t + \dots \right)$$

$$m(t) = \frac{2}{\pi} \left(\sin 2 \pi 1000 t + \frac{1}{3} \sin 2 \pi 3000 t + \frac{1}{5} \sin 2 \pi 5000 t + \dots \right)$$

$$m(f) = j \frac{1}{\pi} [\delta(f + 1000) + \delta(f - 1000)] + j \frac{1}{3 \pi} [\delta(f + 3000) + \delta(f - 3000)] \\ + j \frac{1}{5 \pi} [\delta(f + 5000) + \delta(f - 5000)]$$

AM wave:

$$x(t) = A_c [1 + k_a m(t)] \sin 2 \pi f_c t$$

$$x(t) = 1 \left[1 + k_a \frac{2}{\pi} \left(\sin 2 \pi 1000 t + \frac{1}{3} \sin 2 \pi 3000 t \right. \right. \\ \left. \left. + \frac{1}{5} \sin 2 \pi 5000 t \right) \right] \sin 2 \pi 20000 t$$

$$\begin{aligned}
X(f) = & j\frac{1}{2} [\delta(f + 20000) + \delta(f - 20000)] + k_a \frac{1}{2\pi} [\delta(f + 19000) + \delta(f - 19000)] \\
& + k_a \frac{1}{2\pi} [\delta(f + 21000) + \delta(f - 21000)] + k_a \frac{1}{6\pi} [\delta(f + 17000) + \delta(f - 17000)] \\
& + k_a \frac{1}{6\pi} [\delta(f + 23000) + \delta(f - 23000)] + k_a \frac{1}{10\pi} [\delta(f + 15000) + \delta(f - 15000)] \\
& + k_a \frac{1}{10\pi} [\delta(f + 25000) + \delta(f - 25000)]
\end{aligned}$$

Q: Using the crosshairs on the RAPIDS system, measure the modulation index for each case. How does this effect the output of the envelope detector?

A:

<100% :	$[(5-1.6)/(5 + 1.6)] \times 100 = 51.5\%$, $k_a = .515$
=100% :	$[(2.6-0)/(2.6 + 0)] \times 100 = 100\%$, $k_a = 1$
>100% :	$[(1.5-(-.8))/(1.5 + (-.8))] \times 100 = 328.6\%$, $k_a = 3.2857$

Q: Compute and draw the spectra of of the modulated sine wave.

A: $x(t) = 1 [1 + k_a \sin 2\pi 1000 t] \sin 2\pi 20000 t$

$$\begin{aligned}
X(f) = & j\frac{1}{2} [\delta(f + 20000) + \delta(f - 20000)] + k_a [\delta(f + 19000) + \delta(f - 19000)] \\
& + k_a [\delta(f + 21000) + \delta(f - 21000)]
\end{aligned}$$

Q: What effect does the modulation index have on the spectra of each signal?

A: Increasing the modulation increases the sideband amplitudes and decreases the carrier amplitude.

1f) **Q:** You will have to adjust the plot scale for the detected signal (channel C), why?

A: Power is decreased during modulation. The power of the carrier and the sidebands are:

$$\text{Carrier Power} = \frac{1}{2} A_c^2$$

$$\text{Sideband Power} = \frac{1}{8} k_a A_c^2$$

Q: At what modulation index does DSBSC occur?

A: $k_a = (1+1)/(1-1) = \infty$

Q: What are the time and frequency representations of the DSBSC signal?

A: $x(t) = A_c \sin 2\pi f_c t * A_m \sin 2\pi f_m t$

$$x(t) = .25 (\cos 2\pi 19000 t - \cos 2\pi 21000 t)$$

$$X(f) = \frac{1}{4} \left[\frac{1}{2}(\delta(f + 19000) + \delta(f - 19000)) + \frac{1}{2}(\delta(f + 21000) + \delta(f - 21000)) \right]$$

Q: What is the power of the DSBSC AM signal?

A:
$$P = \frac{1}{2} A_c^2 = (0.5)(1^2) = 0.5$$

Q: If the output of the envelope detector was passed through a BPF centered at 21 KHz, what type of output would we see? Sketch the output. What would the frequency representation be? What would the power be?

A: The output would be Single Sideband centered at 21K:

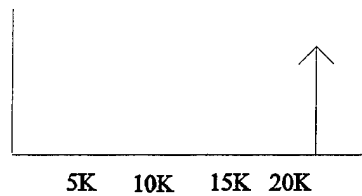

$$X(f) = \frac{1}{8}(\delta(f + 21000) + \delta(f - 21000))$$

$$P = \frac{1}{4} A_c^2 = .25 \cdot 1^2 = .25$$

2a) **Q:** How do the tones differ? What does this tell you about the quality of this detector?

A: The tone of the envelope detector is higher, indicating it is removing lower frequencies. It could be improved.

2b) **Q:** What are these frequencies?

A: $1.5 \text{ MHz} + 500 \text{ Hz} = 1,500,500 \text{ Hz}$

$1.5 \text{ MHz} - 500 \text{ Hz} = 1,499,500 \text{ Hz}$

Q: Compare these tones with that emitting from the radio.

A: The tone from the radio and the original tone are the same. The tone from the envelope detector is higher pitched and lower in power. Some of the frequencies in the message signal are eliminated by the envelope detector.

2c) **Q:** Compare the tones heard on the radio to the original.

A: They are the same.

Q: What is the time domain complex envelope this wave?

A:

$$s(t) = .5 (2\pi 10000 + \beta \left(\frac{4}{\pi} \sin 2\pi 1000 t + \frac{4}{3\pi} \sin 2\pi 3000 t + \frac{4}{5\pi} \sin 2\pi 5000 t \right))$$

$$s(t) = (.5 \cos 2\pi 10000) S_I - (.5 \sin 2\pi 10000) S_Q$$

$$s(t) = .5 \cos 2\pi 10000 t \cos \beta \left(\frac{4}{\pi} \sin 2\pi 1000 t + \frac{4}{3\pi} \sin 2\pi 3000 t + \frac{4}{5\pi} \sin 2\pi 5000 t \right) \\ - .5 \sin 2\pi 10000 t \sin \beta \left(\frac{4}{\pi} \sin 2\pi 1000 t + \frac{4}{3\pi} \sin 2\pi 3000 t + \frac{4}{5\pi} \sin 2\pi 5000 t \right)$$

$$S_I = \cos \beta \left(\frac{4}{\pi} \sin 2\pi 1000 t + \frac{4}{3\pi} \sin 2\pi 3000 t + \frac{4}{5\pi} \sin 2\pi 5000 t \right)$$

$$S_Q = \sin \beta \left(\frac{4}{\pi} \sin 2\pi 1000 t + \frac{4}{3\pi} \sin 2\pi 3000 t + \frac{4}{5\pi} \sin 2\pi 5000 t \right)$$

$$s_{compens}(t) = S_I + j S_Q$$

3b) **Q:** What are positive and negative frequency deviations, f^+ and f^- . What is the peak frequency deviation? What is the modulation index (β)? Measure $2\Delta f$ on the spectrum analyzer for this value of β ?

A: Measured values of f^+ and f^- :

$$f^+ = (1.720 \times 10^{-3} - 1.58 \times 10^{-3})^{-1} = 7142 \text{ Hz}$$

$$f^- = (1.250 \times 10^{-3} - 1.03 \times 10^{-3})^{-1} = 10.526 \approx 10 \text{ kHz}$$

$$2\Delta f = f^+ - f^- = 3383 \text{ Hz} \quad \Delta f = 1692 \text{ Hz}$$

$$\beta = \Delta f / f_m = 1692 / 1000 = 1.692 \text{ Hz}$$

$$\text{measured value of } 2\Delta f = 10980 - 7568 = 3412 \text{ Hz}$$

Q: Using Carsons rule, what is the bandwidth for this signal?

$$\text{A: } B = 2\Delta f + 2f_m = 3412 + 2(1000) = 5412 \text{ Hz}$$

Q: What is the frequency representation of the FM sine wave.

A:

$$S(f) = A_c \sum_n J_n(\beta) [\delta(f - f_c - nf_m) + \delta(f + f_c + nf_m)]$$

$$\beta = 1.692 \quad J_0(\beta) = .4 \quad J_1(\beta) = .5 \quad J_2(\beta) = .3 \quad J_3(\beta) = .1$$

Q: Measure f^+ , f^- and $2\Delta f$. What is the frequency deviation? What is β and the bandwidth?

$$\mathbf{A:} \quad f^+ = (.75 \times 10^{-3} - .615 \times 10^{-3})^{-1} = 7407 \text{ Hz}$$

$$f^- = (1.36 \times 10^{-3} - 1265 \times 10^{-3})^{-1} = 10.526 \approx 10 \text{ KHz}$$

$$2\Delta f = 3119 \text{ Hz} \quad \Delta f = 1560 \text{ Hz}$$

$$\beta = \Delta f / f_m = 1.56 \text{ Hz}$$

$$B = 2(1560) + 2000 = 5120 \text{ Hz}$$

The plots listed below are attached in order:

- Plot 1: Square wave and 100% AM square wave
- Plot 2: Square wave spectrum
- Plot 3: 100% modulated square wave spectrum
- Plot 4: Sine wave, <100% modulated sine wave and detected sine wave
- Plot 5: Spectrum of <100% modulated sine wave
- Plot 6: Sine wave, =100% modulated sine wave and detected sine wave
- Plot 7: Spectrum of =100% modulated sine wave
- Plot 8: Sine wave, >100% modulated sine wave and detected sine wave
- Plot 9: Spectrum of >100% modulated sine wave
- Plot 10: Sine wave, AM DSBSC wave and detected sine wave
- Plot 11: Spectrum of AM DSBSC wave
- Plot 12: Square wave and FM square wave
- Plot 13: Spectrum of FM square wave
- Plot 14: Sine wave and FM sine wave
- Plot 15: Spectrum of FM sine wave

SQUARE WAVE 100% MODULATION

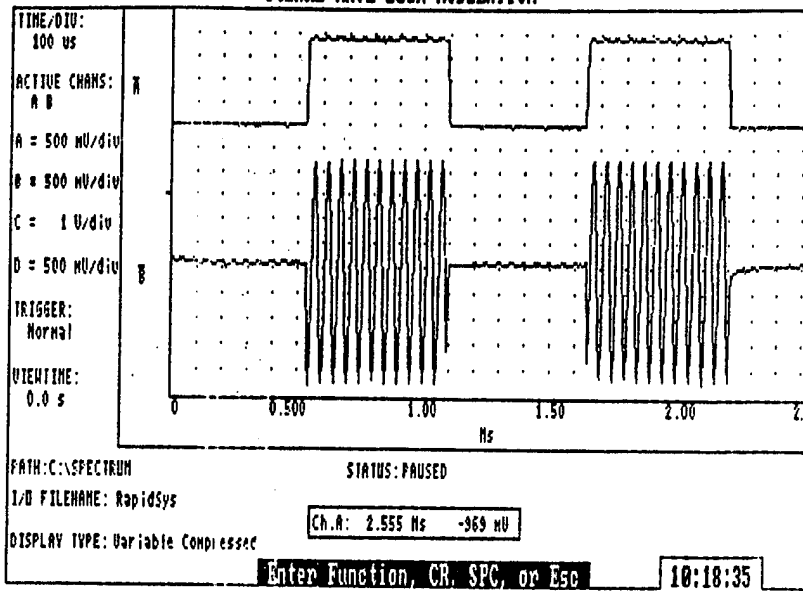

Plot 1

SQUARE WAVE SPECTRUM

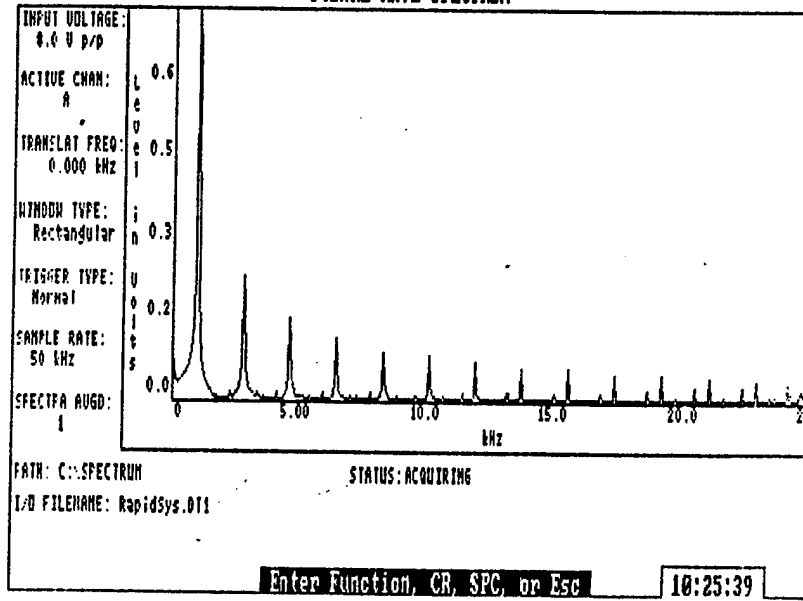

Plot 2

AM LESS THAN 100% MODULATION

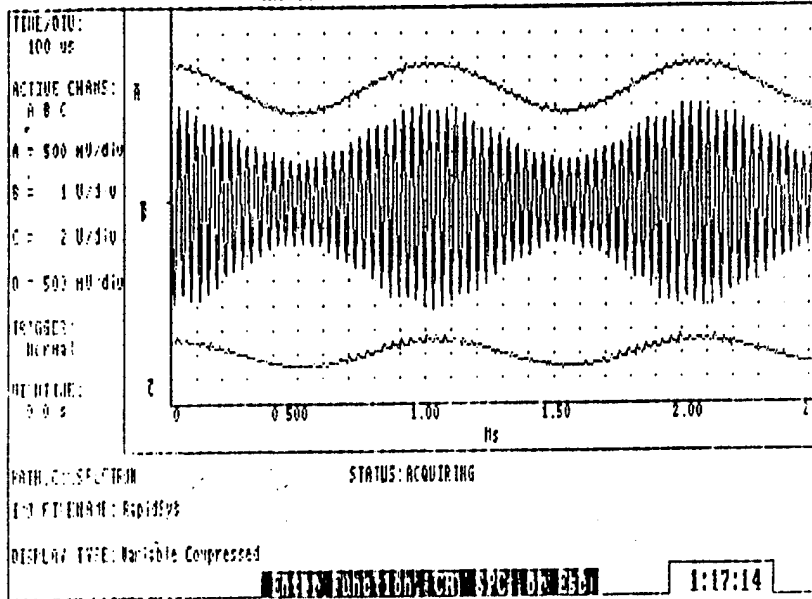

Plot 3

AM LESS THAN 100% MODULATION

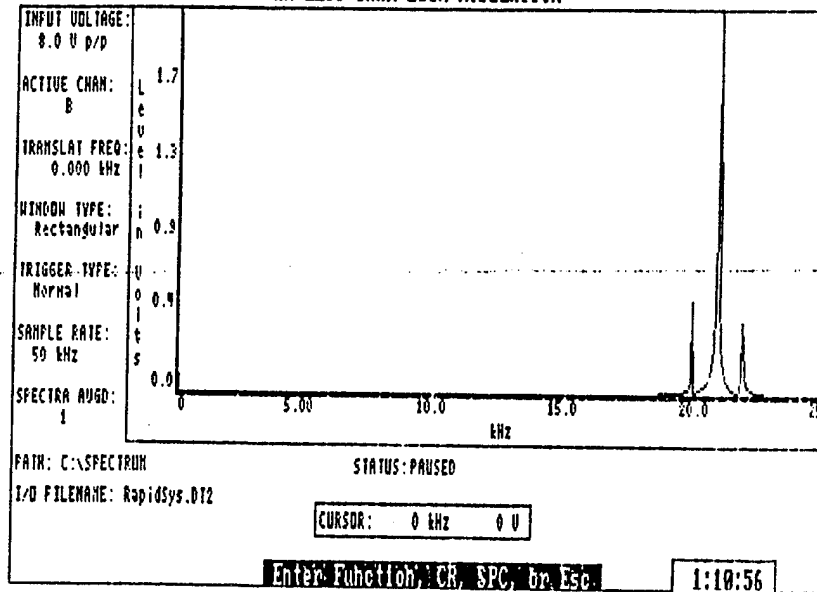

Plot 4

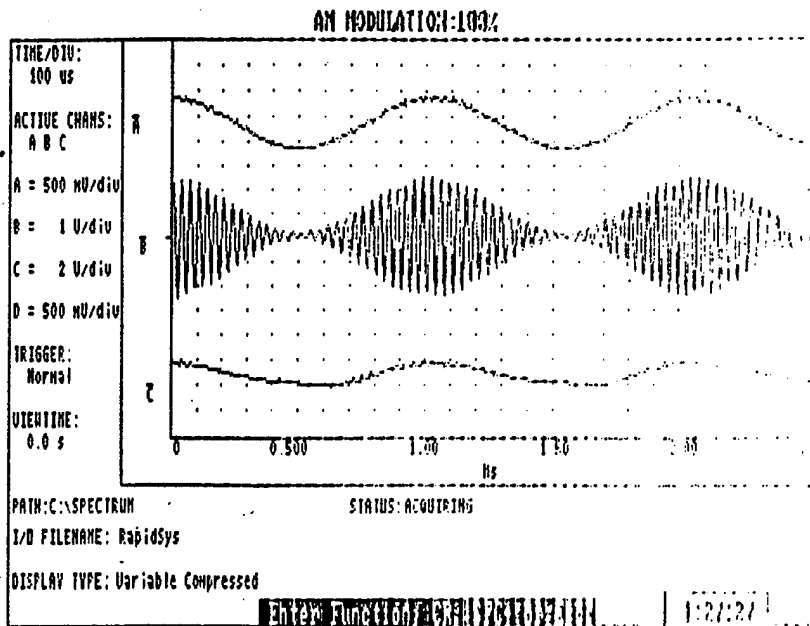

Plot 5

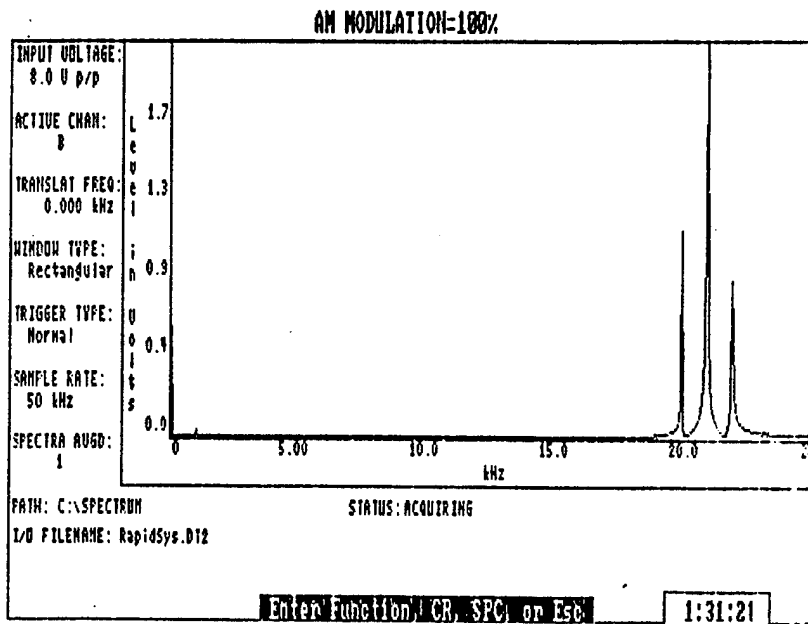

Plot 6

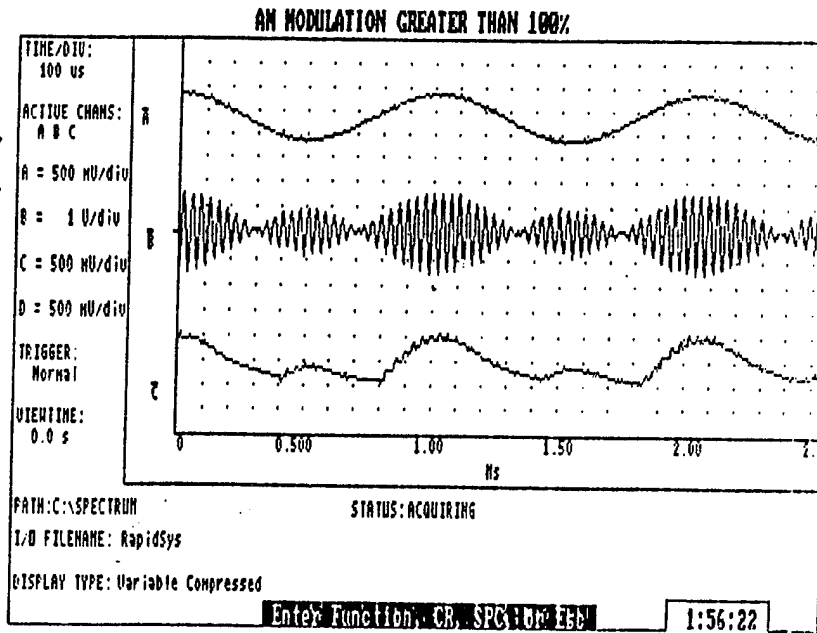

Plot 7

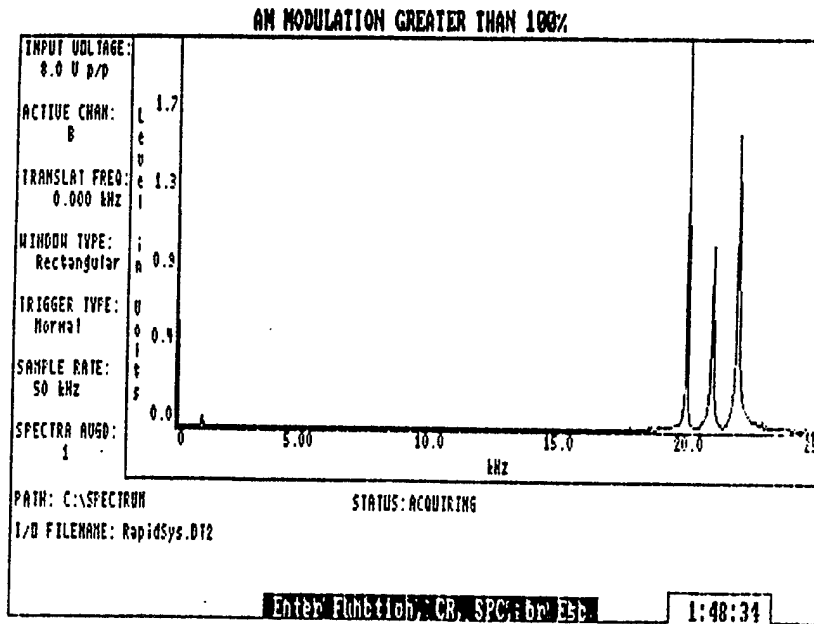

Plot 8

1 KHz SQUARE WAVE MODULATED ON 20KHz CARRIER

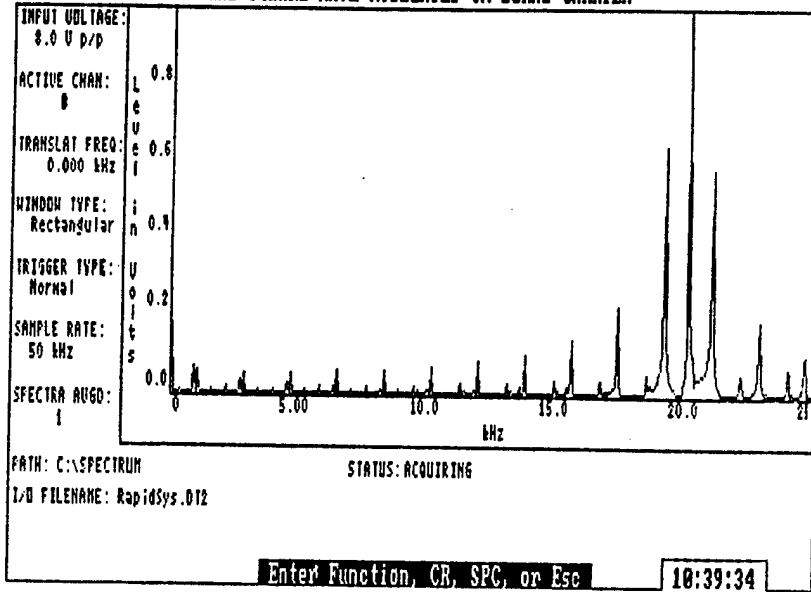

Plot 9

AM DSBS

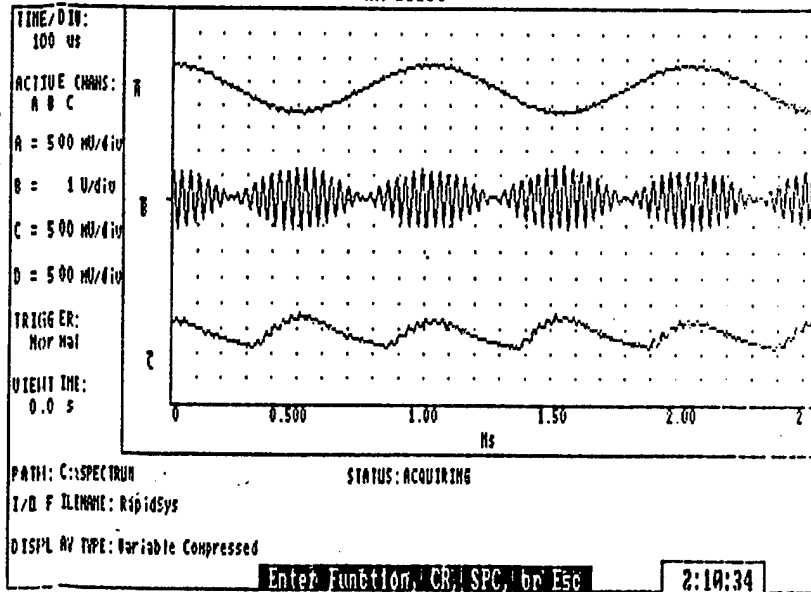

Plot 10

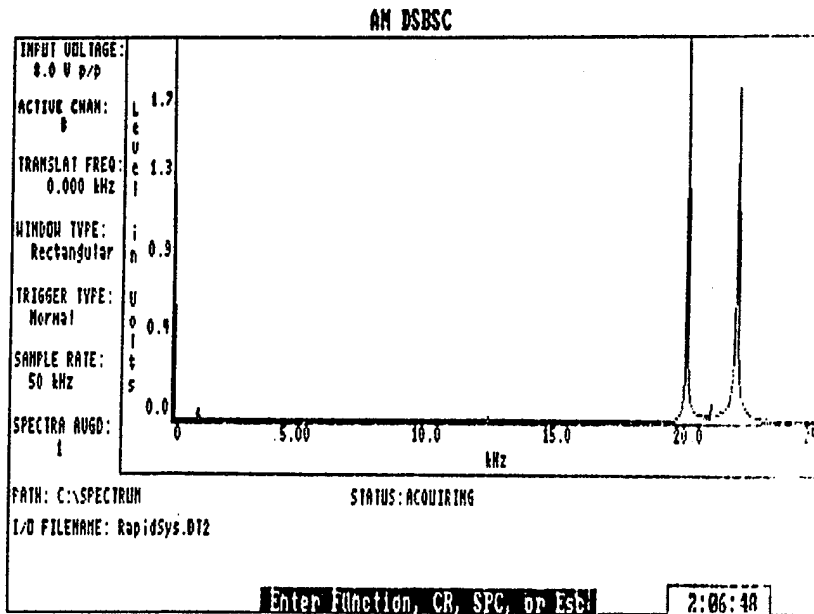

Plot 11

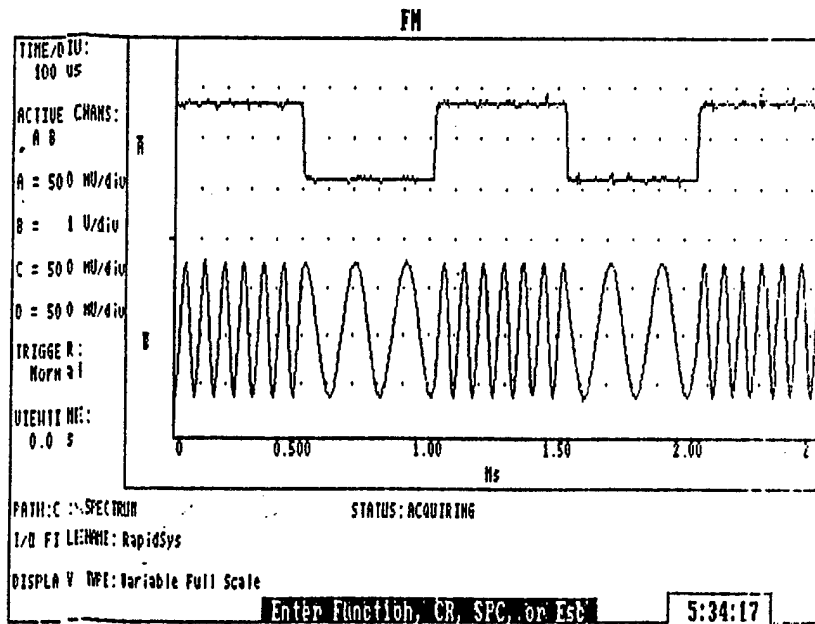

Plot 12

FM SQ WAVE

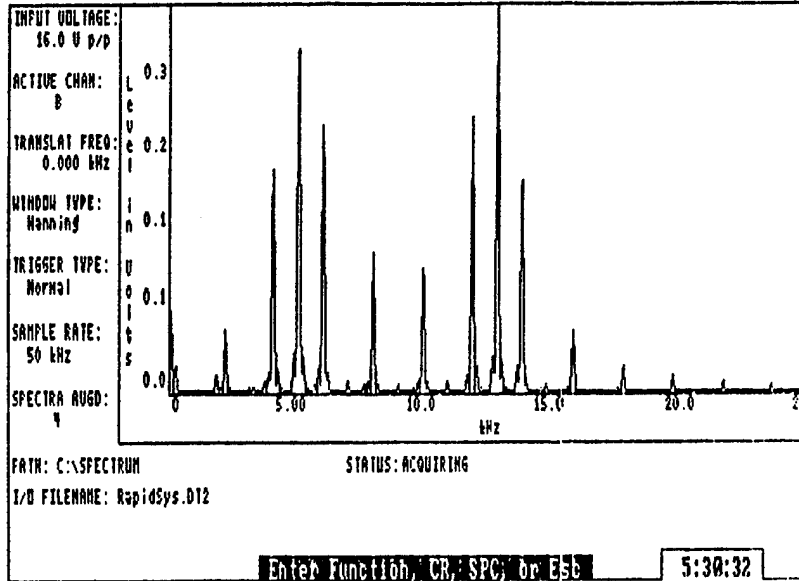

Plot 13

FM

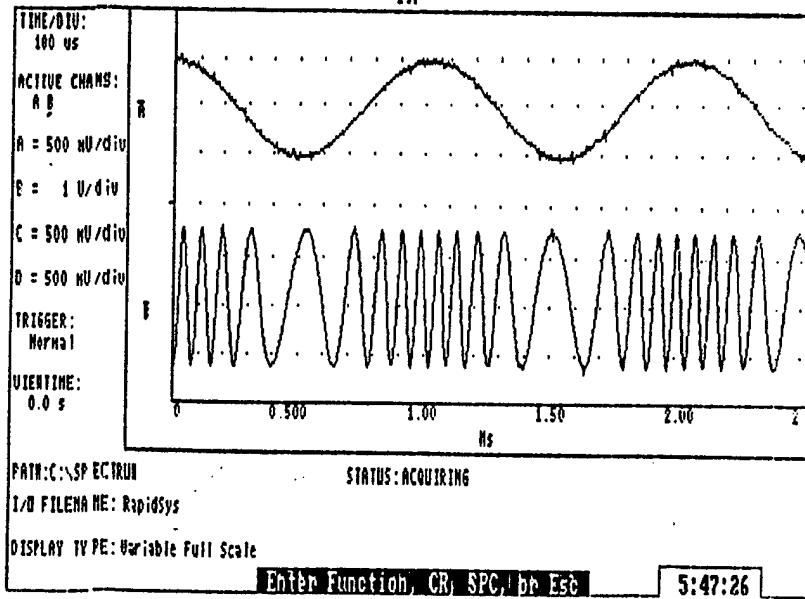

Plot 14

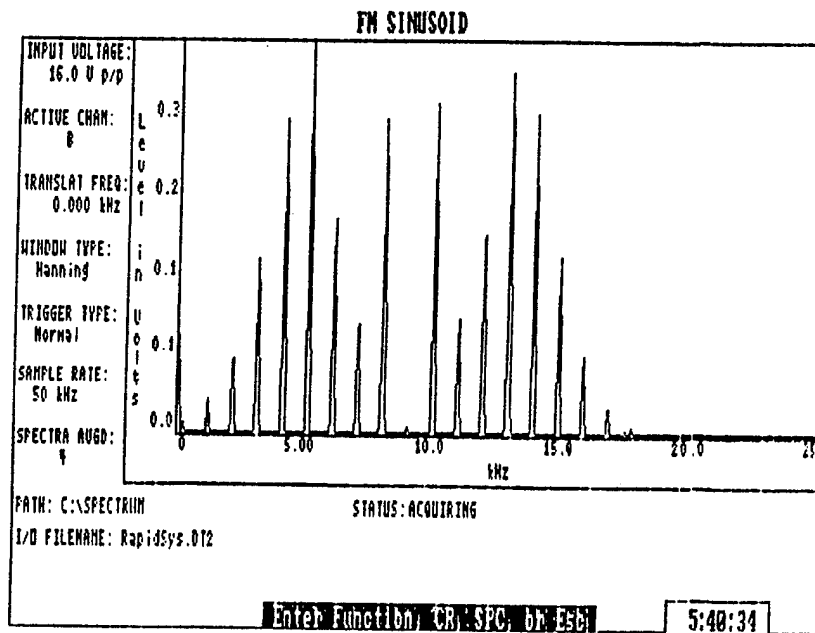

Plot 15

LAB 3 Supply List

Based on 25 student class, 2-3 persons/team.

Equipment	Required/Team	On/Hand
Wavetek 132 or 142	2	24
RAPIDS station	1	10
Tektronix DM502A	1	25
Tektronix PS503	1	35
1 Wavetek 186	1	12
1 Speaker	1	10
1 HP8656B sig gen	1	7
1 AM radio	1	1
1 461A Amp	1	7
1 Antenna	1	1

The number of teams is limited to 7, the number of HP8656B signal generators available. Although there is only one radio and antenna, the use of these is limited so they can be shared. Recommend purchasing more speakers, and a few more radios and antennae of better quality.

Components	Required/Team	On/Hand
N4764 Diode	1	40
μ A741 Op Amp	1	>50
Resistors/Capacitors - plenty available		

APPENDIX D. LABORATORY 4

Lab 4: Frequency-Division Multiplexing and Time-Division Multiplexing

Objective: To generate Frequency-Division Multiplexed (FDM) and Time-Division Multiplexed (TDM) signals. Measure and observe the FDM spectra. Observe the composite TDM signal in the time domain.

Equipment:

- (1) Breadboard
- (2) Wavetek model 132 signal generator
- (1) Tektronix P5S03 power supplies
- (1) Tektronix DM502A Digital Multimeter (DMM)
- (1) Tektronix 2445B Oscilloscope
- (2) Wavetek model 186 signal generator
- (1) HP8656B signal generator
- (1) HP8590B spectrum analyzer

Components:

- (1) 4001 NOR (Inverting OR)
- (1) CD4029B Up/Down counter
- (1) CD4051B CMOS analog multiplexer
- (1) XR8038 Precision waveform generator
- (2) 330 K Ω resistors
- (3) 10 K Ω resistors
- (1) 68 K Ω resistor
- (1) 22 K Ω resistor

- (1) 100 Ω resistor
- (1) 10 μ f capacitor
- (1) .1 μ f capacitor
- (1) .047 μ f capacitor
- (1) .0033 μ f capacitor

Part 1: Frequency-Division Multiplexing

a) Turn on the power to the HP8590B and the HP8656B systems. Press RF OFF to ensure the RF is off. Using the oscilloscope, configure one Wavetek 186 to produce a 200 mV peak-to-peak (pp), 300 kHz sine wave. This signal will be referred to as f_1 . Configure the second Wavetek 186 to produce a 200 mV pp, 400 kHz sine wave. This signal will be referred to as f_2 . Configure both Wavetek 132's to produce 5 V pp, 10 kHz sine waves. These will be referred to as f_{m1} and f_{m2} .

$$f_{m1} = f_{m2} = 10 \text{ kHz}, \quad f_1 = 300 \text{ kHz}, \quad f_2 = 400 \text{ kHz}.$$

b) Connect f_{m1} to VCA IN on the appropriate Wavetek 186 to modulate it with f_1 . Apply the Wavetek 186 output to the input of the spectrum analyzer. Follow the directions below to measure the spectrum of the AM wave on the spectrum analyzer:

- 1) There will be a spike on the far left of the screen. Press AMP and rotate the knob so the amplitude of the signal is touching the top of the graticule.
- 2) Press FREQ and rotate the knob so the large center spike is at the center of the screen.
- 3) Press SPAN and rotate the knob so the span of the display decreases. When the spike goes off the screen, repeat step two. Keep decreasing the span in this manner until you are able to see the right side spectrum of the carrier frequency and its side

bands as you saw them in laboratory 3 on the RAPIDS screen.

4) Press MKR and place the marker on the zero frequency spike. The spike represents a DC component within the machine itself. Note that the frequency reading on the screen will not read zero. This is due to the ± 5 MHz accuracy rating on the system. On the marker menu, located on the screen press DELTA Marker. Rotate the knob to read the frequency of the lower and upper sidebands in relationship to the center frequency spike.

Q: What are the frequencies for the carrier (f_1) and its upper and lower sidebands.

Repeat step b to modulate f_{m2} onto the carrier f_2 . **Q:** What are the frequencies for the carrier (f_2) and its upper and lower sidebands.

c) Using a T-connector, connect both of the AM signals from the Wavetek 186's to the input of the spectrum analyzer. This will add the signals together. Your configuration should now look like Figure 1.

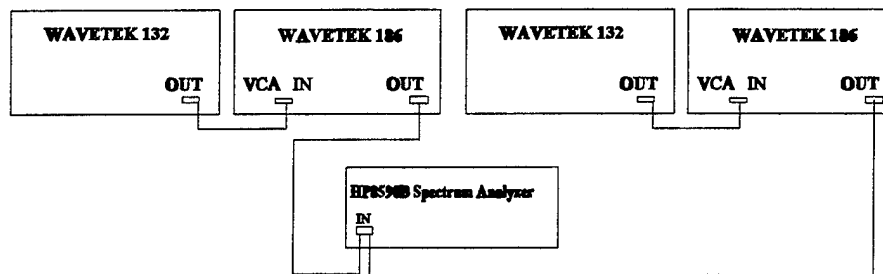

Figure 1

Q: Measure the frequencies of the spectral components and sketch them. You will have to alternate between **FREQ** and **MKR** after choosing **DELTA** Marker to measure each frequency. Q: What is the bandwidth of each signal? Q: What is the bandwidth of the two signals added together? Q: What is the ΔB to avoid crosstalk? Q: Change f_{m2} to 50 kHz, measure, sketch and calculate the frequency spacing again. While viewing the 300 kHz signal and its sidebands, lower the frequency of f_1 and watch the sidebands come into view. Q: At what frequency does crosstalk occur? Why?

d) Change the frequencies of f_{m1} and f_{m2} to 80 kHz and f_1 to 500 kHz. At this point you have two identical messages that have been shifted to provide frequency separation. Now you will modulate them as one signal on a 1 MHz carrier. Move the two signals from the input of the spectrum analyzer to the input of the signal generator. Connect RF out of the signal generator to the input of the spectrum analyzer. Press preset on the spectrum analyzer. Press RF OFF to turn the RF on. Set up the signal generator as in laboratory 3 for 30% amplitude modulation on a 1 MHz carrier with a -7dB output amplitude. Q: Using the same techniques as outlined in part a, measure the frequencies of the carrier and all of its sidebands and sketch the spectrum. Annotate the theoretical values as well as the actual values. Change the frequencies of f_{m1} and f_{m2} to 100 kHz. Q: Measure all the frequencies again and explain the output.

Part 2: Time-Division Multiplexing Demonstration

a) Construct the TDM circuit of Figure 2. The CD4051 multiplexor in this circuit provides the commutator function. The commutator combines four signals into a TDM signal. The TDM inputs are four signals: triangle wave at pin 14, two sine waves at pins 12 and 5, and a DC voltage at pin 4. Apply a 5 Vpp, 30 Hz sine wave to V_{in} . Q: Using

a probe and the oscilloscope, verify the amplitude, frequency and period of each input wave. The commutator clock frequency can be measured at pin 15 of the CD4029. **Q:** Measure the clock frequency and period. With the information you have predict what the TDM signal will look like. The output can be seen at pin 3 of the CD4051. Increase the oscilloscope scale and ensure that each signal is being sampled in the order you predicted. **Q:** Measure the period of one sample of the TDM signal. Explain how it does/does not differ from your prediction. **Q:** What is the bandwidth of this signal?

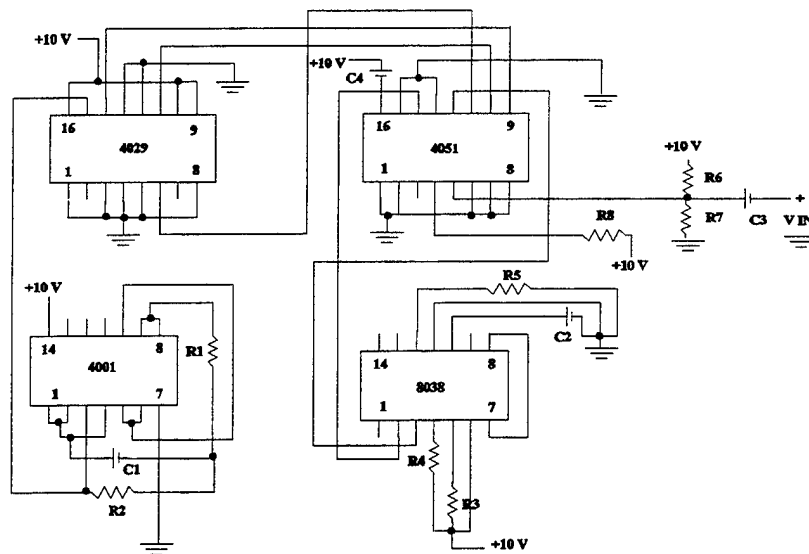

Figure 2

$R_1 = 100\Omega$, $R_2 = 22\text{ K}\Omega$, $R_3 = R_4 = 330\text{ K}\Omega$, $R_5 = 68\text{ K}\Omega$, $R_6 = R_7 = R_8 = 10\text{ K}\Omega$
 $C_1 = 0.0033\ \mu\text{f}$, $C_2 = 0.047\ \mu\text{f}$, $C_3 = 10\ \mu\text{f}$, $C_4 = .1\ \mu\text{f}$

Lab 4: Frequency-Division Multiplexing and Time-Division Multiplexing

Data Sheet

1b) **Q:** What are the frequencies for the carrier (f_1) and its upper and lower sidebands.

Q: What are the frequencies for the carrier (f_2) and its upper and lower sidebands.

1c) **Q:** Measure the frequencies of the spectral components and sketch them.

Q: What is the bandwidth of each signal?

Q: What is the bandwidth of the two signals added together?

Q: What is the ΔB to avoid crosstalk?

Q: Change f_{m2} to 50 kHz, measure, sketch and calculate the frequency spacing again.

Q: At what frequency does crosstalk occur? Why?

1d) **Q:** Measure the frequencies of the carrier and all of its sidebands and sketch the spectrum of the FDM signal. Annotate the theoretical values as well as the actual values.

Q: Measure all the frequencies again and explain the output.

2a) **Q:** Using a probe and the oscilloscope, verify the amplitude, frequency and period of each input wave.

Q: Measure the clock frequency and period.

Q: Predict what the signal will look like.

Q: Measure the period of one sample of the TDM signal. Explain how it does/does not differ from your prediction.

Q: What is the bandwidth of this signal?

Lab 4: Frequency-Division Multiplexing and Time-Division Multiplexing

Solutions

1b) Q: What are the frequencies for the carrier (f_1) and its upper and lower sidebands.

A:

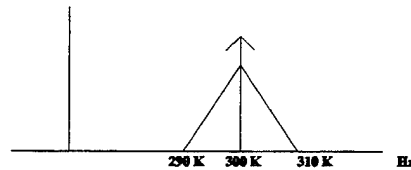

Q: What are the frequencies for the carrier (f_2) and its upper and lower sidebands.

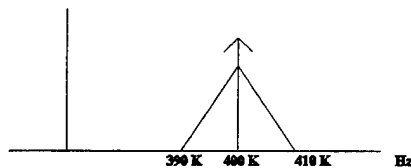

1c) Q: Measure the frequencies of the spectral components and sketch them.

A:

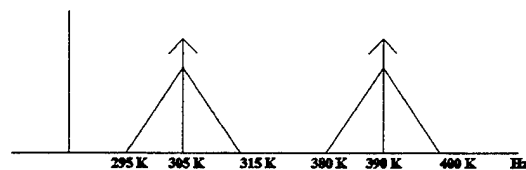

Q: What is the bandwidth of each signal?

A: The bandwidth of each signal is 20 kHz.

Q: What is the bandwidth of the two signals added together?

A: The bandwidth of the combined signal is 40 kHz.

Q: What is the ΔB to avoid inter modulation products?

A: $\Delta B = 75 \text{ kHz}$

Q: Change f_{m2} to 50 kHz, measure, sketch and calculate the frequency spacing again.

A:

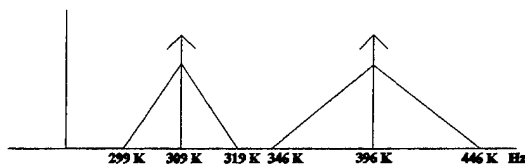

Q: At what frequency does crosstalk occur? Why?

A: Cross talk occurs at 340 kHz. At 340 kHz the lower sideband extends to 310 kHz and overlaps the upper sideband of the 300 kHz signal.

1d) **Q:** Measure the frequencies of the carrier and all of its sidebands and sketch the spectrum of the FDM signal. Annotate the theoretical values as well as the actual values.

A:

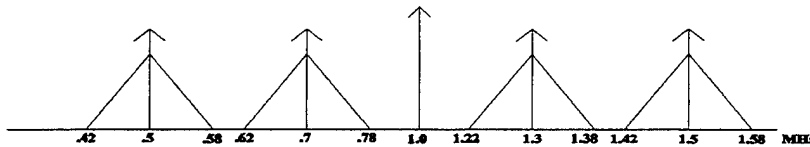

Q: Measure all the frequencies again and explain the output.

A:

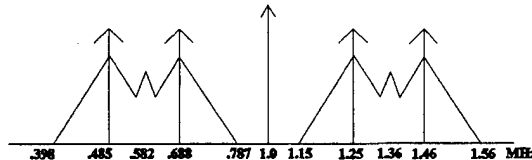

Changing the messages to 100 kHz caused the upper and lower sidebands to cross and produce crosstalk.

2a) **Q:** Using a probe and the oscilloscope, verify the amplitude, frequency and period of each input wave.

- A:** Pin 4: DC voltage at 10 volts
 Pin 5: input sine wave, 5 Vpp, 30 Hz, T = 0.033 sec
 Pin 12: triangle wave, 3 V pp, 18 Hz, T = 0.055 sec
 Pin 15: sine wave, 2 V pp, 18 Hz, T = 0.055 sec

Q: Measure the clock frequency and period.

A: $f = 7.5 \text{ kHz}$, $T = 0.133 \times 10^{-3} \text{ sec}$

Q: Predict what the signal will look like.

A:

SIG 1	SIG 2	SIG 3	SIG 4		SIG 1	SIG 2	SIG 3	SIG 4
-------	-------	-------	-------	--	-------	-------	-------	-------

Q: Measure the period of one sample of the TDM signal. Explain how it does/does not differ from your prediction.

A: The measured period is at $0.136 \times 10^{-3} \text{ sec}$. This matches theory. Each signal gets sampled in turn for a duration of $0.136 \times 10^{-3} \text{ seconds}$.

Q: What is the bandwidth of this signal?

A: The bandwidth expansion factor, N , equals 4. Therefore,
 $B = (4)(18) = 36 \text{ Hz}$.

LAB 4 Equipment List

Based on 25 student class, 2-3 persons/team.

Equipment	Required/Team	On/Hand
Wavetek 132 or 142	2	24
Tektronix DM502A	1	25
Tektronix PS503	1	35
Wavetek 186	2	12
HP8656B sig gen	1	7
HP8590B Spec An	1	9
Tektronix 2445B	1	10

Components	Required/Team	On/Hand
4001 NOR	1	>50
CD4029B	1	0
CD4051B	1	>50
XR8038	1	0

Resistors/Capacitors - plenty available

The number of teams is limited to 7. This lab requires the purchase of CD4029 Up/Down counters and XR8038 waveform generators.

APPENDIX E. LABORATORY 5

Lab 5: Phase Locked Loop

Objective: To use the NE565 Phase Locked Loop (PLL) integrated circuit to demodulate a FM signal.

Equipment:

- (1) Breadboard
- (1) Wavetek models 132 and 186 signal generators
- (1) Tektronix P5S03 power supplies
- (1) Tektronix 2445B Oscilloscope (see lab 1 for operation)
- (1) Tektronix DM502A Digital Multimeter (DMM)

Components:

- (1) NE565 PLL IC
- (2) 680 Ω resistors
- (1) resistor to be determined
- (2) 0.1 μf capacitors
- (2) .001 μf capacitors

Part1: Free Running PLL

a) Design the PLL circuit to have a center frequency of 64 kHz. The center frequency f_o , capture frequency f_c and lock frequency f_l , are determined by the external resistors and capacitors chosen. The time constant is determined by the selection of capacitor C_2 . For our purposes C_2 is .1 μf . Q: Use the following equations to determine

R_1 , f_c , and f_l for $V_{cc} = \pm 10$ volts. Component values can be found on figure 1.

$$f_o = \frac{1.2}{4 R_1 C_1} \qquad f_c = \frac{1}{2\pi} \sqrt{\frac{2\pi f_l}{\tau}}$$

$$f_l = \frac{8 f_o}{V_{cc}} \qquad \tau = 3.6 \times 10^3 C_2$$

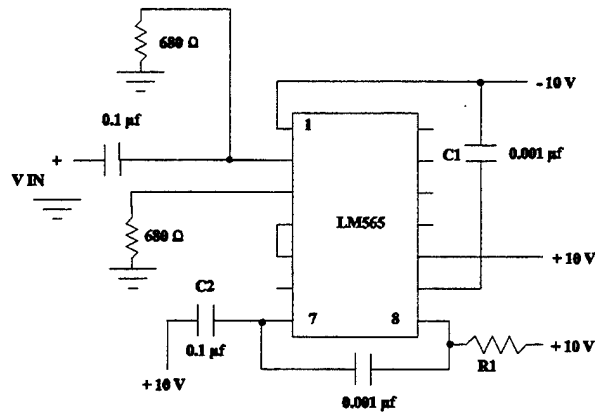

Figure 1

b) Build the circuit shown in figure 1 using your calculated value for R_1 . Measure the actual values of the resistors and capacitors used. Connect a ground bus, a + 10 volt bus and a - 10 volt bus to your breadboard from an HP power supply.

c) Display a 100 kHz sine wave with an amplitude of .25 mv from the Wavetek 186, on the oscilloscope channel 2. Adjust the Wavetek 186 settings to:

Waveform: sinusoid norm

symmetry: norm

Gen mode: cont

atten: 20dB

Adjust the oscilloscope settings (see lab 1 for operation) to:

Ch1: 5 v/div, AC

Ch2: 500 mv/div, AC

After you have verified that the signal looks as expected, connect it in series with the capacitor that is connected to pin 2. Maintain a reading of the signal on channel 2. Monitor the output of the free running PLL from pin 4 on channel 1 of the oscilloscope. Adjust the vertical position of each signal so they do not overlap. Vary the frequency of the 186 output and watch the output pulse of the PLL. During the capture and lock range, the frequency of the output should be equal to the frequency of the input (ie: it is locked). **Q:** By varying the frequency, determine the range that the PLL remains locked (upper and lower frequencies). Bring the frequency outside the lower lock frequency. Slowly increase the frequency to determine the lower capture frequency at which the PLL follows the input frequency. Repeat for upper capture frequency. Determine the center frequency. **Q:** What is the amplitude of the output?

d) **Q:** Recalculate the theoretical values of f_o , f_c , and f_l using the actual values of the resistors and capacitors. Compare these values to the measured frequencies.

e) Change the values of V_{cc} to ± 6 volts. **Q:** Recalculate the theoretical values of f_o , f_c , and f_i using the actual values of the resistors and capacitors. **Q:** What effect does the power supply to the chip have on the output. **Q:** Repeat the procedure used in c) to determine the lock and capture ranges and center frequency for $V_{cc} = \pm 6$ volts. **Q:** What is the amplitude of the output?

f) Change the amplitude of the input to .375 mv. **Q:** Measure f_c and f_i . Repeat for amplitudes of .5mv and 1 mv. Comment on the effects of these frequencies.

Part 2: FM Demodulation

a) Return V_{cc} to ± 10 volts. From the Wavetek 132, verify a .05mv, 100 Hz sine wave on channel 3 of the oscilloscope. Split the line from the Wavetek 132 and send the signal to VCG in on the Wavetek 186 to produce a FM signal out of the Wavetek 186. Adjust the Wavetek 132 settings to:

Seq length: $2^{10}-1$

atten: 20 dB

mode: func

The "shadowing" on the signal is due to the frequency deviation of the FM signal. **Q:** Vary the carrier frequency (186), measure f_c and f_i . Take care to measure leading edge to leading edge (or visa versa). **Q:** Comment on the difference (if any) from those of the free running configuration.

b) Increase the message signal (132) to 1000 hz. **Q:** Measure f_o , f_c and f_i for $f_m = 1000$ hz.

c) Verify that channel 3 is your message signal, channel 2 is the FM input to the PLL and channel 2 is the output signal. Move the output measurement probe to pin 7. This is the demodulated output pin. The PLL demodulates with a 90° phase shift and amplifies the signal via an internal amplifier. **Q:** Is the output shifted? What is the amplitude? Switch the message signal to a triangle wave. **Q:** Is the output shifted? What is the amplitude? Vary the frequency of the carrier. **Q:** What happens to the demodulated output when the frequency exceeds the lock range?

Lab 5: Phase Lock Loop

Data Sheet

1a) **Q:** Use the following equations to determine f_o , f_c , and f_l for $V_{cc} = \pm 10$ volts.
Component values can be found on figure 1.

$$f_o = \frac{1.2}{4R_1C_1} \quad f_l = \frac{8f_o}{V_{cc}} \quad \tau = 3.6 \times 10^3 C_2 \quad f_c = \frac{1}{2\pi} \sqrt{\frac{2\pi f_l}{\tau}}$$

Measured values for: $R_1 =$ _____ , $C_1 =$ _____ , $C_2 =$ _____

1c) **Q:** By varying the frequency, determine the range that the PLL remains locked (upper and lower frequencies).

A: f_{ll} f_{cl} f_o f_{cu} f_{lu}
 | | | | |

Lock range: _____

Capture range: _____

Q: What is the amplitude of the output?

1d) **Q:** Recalculate the theoretical values of f_o , f_c , and f_l using the actual values of the resistors and capacitors.

1e) **Q:** With $V_{cc} = \pm 6$ volts, recalculate the theoretical values of f_o , f_c , and f_l using the actual values of the resistors and capacitors.

Q: What effect does the Power supply to the chip have on the output.

Q: What are the measured values for lock and capture ranges and center frequency for $V_{cc} = \pm 6$ volts.

A: f_{ll} f_{cl} f_o f_{cu} f_{lu}
 | | | | |

Lock range: _____ Capture range: _____

Q: What is the amplitude of the output?

1f) Q: What are f_c , and f_i for an input amplitude of .375 mv, .5mv and 1 mv?

A: Amp f_i f_c f_c f_i

1Vpp

2Vpp

.75Vpp

2a) Q: Vary the carrier frequency (186) and measure f_o , f_c , and f_i .

A: f_{ll} f_{cl} f_o f_{cu} f_{lu}
 | | | | |

Lock range: _____ Capture range: _____

Q: Why does this differ from the free running configuration?

2b) Q: Measure f_o , f_{cl} and f_l for $f_m = 1000$ hz.

A: f_l f_{cl} f_o f_{cu} f_{lu}
| | | | |

Lock range: _____ Capture range: _____

2c) Q: Is the output shifted? What is the amplitude?

Q: For a triangle wave, is the output shifted? What is the amplitude?

Q: What happens when the frequency exceeds the lock range?

Lab 5: Phase Locked Loop

Solutions

1a) Q: Use the following equations to determine f_o , f_c , and f_i for $V_{cc} = \pm 10$ volts.
Component values can be found on fig 1.

$$f_o = \frac{1.2}{4R_1C_1} \quad f_i = \frac{8f_o}{V_{cc}} \quad \tau = 3.6 \times 10^3 C_2 \quad f_c = \frac{1}{2\pi} \sqrt{\frac{2\pi f_i}{\tau}}$$

A: $V_{cc} = \pm 10$

$$64 \times 10^3 = \frac{1.2}{4(R_1)(.001 \times 10^{-6})} \rightarrow R_1 = 4.688 \times 10^3 \Omega$$

$$f_i = \frac{(8)(64 \times 10^3)}{10} = 51.2 \times 10^3 \text{ Hz}$$

$$\tau = (3.6 \times 10^3)(.1 \times 10^{-6}) = .36 \times 10^{-3}$$

$$f_c = \frac{1}{2\pi} \sqrt{\frac{2\pi(51.2 \times 10^3)}{.36 \times 10^{-3}}} = 4751 \text{ Hz}$$

Measured values for: $R_1 = \underline{4.67 \text{ k}\Omega}$, $C_1 = \underline{1.065 \times 10^{-9}}$, $C_2 = \underline{100.2 \times 10^{-9}}$

1c) Q: By varying the frequency, determine the range that the PLL remains locked (upper and lower frequencies).

A:	f_{ll}	f_{cl}	f_o	f_{cu}	f_{lu}
	33.9K	56.1K	59.3K	62.4K	84.7K

Lock range: 50.8 kHz Capture range: 6.3 kHz

Q: What is the amplitude of the output?

A: A=10 V

1d) Q: Recalculate the theoretical values of f_o , f_c , and f_l using the actual values of the resistors and capacitors.

A: $V_{cc} = \pm 10$

$$f_o = \frac{1.2}{4(4.67 \times 10^3)(1.065 \times 10^{-9})} = 60.319 \times 10^3 \text{ Hz}$$

$$f_l = \frac{(8)(64.319 \times 10^3)}{10} = 48.255 \times 10^3 \text{ Hz}$$

$$\tau = (3.6 \times 10^3)(100.2 \times 10^{-9}) = 360.72 \times 10^{-6}$$

$$f_c = \frac{1}{2\pi} \sqrt{\frac{2\pi(48.255 \times 10^3)}{360.72 \times 10^{-6}}} = 4614.2 \text{ Hz}$$

1e) Q: With $V_{cc} = \pm 6$ volts, recalculate the theoretical values of f_o , f_c , and f_l using the actual values of the resistors and capacitors.

A: $V_{cc} = \pm 10$

$$f_o = \frac{1.2}{4(4.67 \times 10^3)1.065 \times 10^{-9}} = 60.319 \times 10^3 \text{ Hz}$$

$$f_l = \frac{(8)(60.319 \times 10^3)}{6} = 80.425 \times 10^3 \text{ Hz}$$

$$\tau = (3.6 \times 10^3)(100.2 \times 10^{-9}) = 360.72 \times 10^{-6}$$

$$f_c = \frac{1}{2\pi} \sqrt{\frac{2\pi(80.425 \times 10^3)}{360.72 \times 10^{-6}}} = 5956.9 \text{ Hz}$$

Q: What effect does the power supply to the chip have on the output.

A: The lock and capture ranges get larger as the supply voltage lowers. The center frequency remains the same.

Q: What are the measured values for lock and capture ranges and center frequency for $V_{cc} = \pm 6$ volts.

A:	f_{ll}	f_{cl}	f_o	f_{cu}	f_{lu}
	16.4K	55.3K	59.9K	64.7K	102.6K

Lock range: 86.2 kHz Capture range: 9.4 kHz

Q: What is the amplitude of the output?

A: A=6 V

1f) Q: What are f_c and f_l for an input amplitude of .375 mv, .5mv and 1 mv?

A:	Amp	f_l	f_c	f_c	f_l
	1Vpp	16.7	54.1	65.2	99.9
	2Vpp	15.8	53.3	64.5	104
	.75Vpp	16.4	53.6	64.2	108

2a) Q: Vary the carrier frequency (Wavetek 186) and measure f_o , f_c and f_l .

A:	f_{ll}	f_{cl}	f_o	f_{cu}	f_{lu}
	25.5K	54.8K	62.6K	70.4K	102K

Lock range: 76.5 kHz Capture range: 15.6 kHz

Q: Why does this differ from the free running configuration?

A: The frequency deviation causes the bandwidth to change. The changes the capture and lock ranges.

2b) Q: Measure f_o , f_c , and f_l for $f_m = 1000$ hz.

A:	f_{ll}	f_{cl}	f_o	f_{cu}	f_{lu}
	25.5K	55.4K	62.6K	70.4K	88.7K

Lock range: 63.2 kHz Capture range: 15.0 kHz

2c) Q: Is the output shifted? What is the amplitude?

A: The output is shifted by 90° with an amplitude of .245V.

Q: For a triangle wave, is the output shifted? What is the amplitude?

A: The output is shifted by 90° with an amplitude of .245V.

Q: What happens when the frequency exceeds the lock range?

A: The circuit does not demodulate the output outside the lock range.

LAB 5 Equipment List

Based on 25 student class, 2-3 persons/team.

Equipment	Required/Team	On/Hand
Wavetek 186	1	12
Wavetek 142	1	12
Tektronix DM502A	1	25
Tektronix PS503	1	35
Tektronix 2445B	1	10

Components

NE565 PLL IC	1	>40
--------------	---	-----

Resistors/Capacitors - plenty available

Plenty of components on hand for 12 teams.

LIST OF REFERENCES

1. Coughlin R. F. and Driscoll F. F., *Operational Amplifiers and Linear Integrated Circuits*, Prentice Hall, Englewood Cliffs, N. J., 1991
2. Miller, G. M., *Modern Electronic Communication*, Regents/Prentice Hall, Englewood Cliffs, N. J., 1978
3. Haykin, S., *An Introduction to Analog and Digital Communications*, John Wiley and Sons Inc., New York, N. Y., 1989
4. Oliver, M. E., *Laboratory Manual to Modern Electronic Communications by Gary M. Miller*, Regents/Prentice Hall, Englewood Cliffs, N. J., 1993
5. Roden, M. S., *Analog and Digital Communications Systems*, Prentice-Hall Inc., Englewood Cliffs, N. J., 1991
6. Couch, L. W., *Digital and Analog Communications Systems*, Macmillan Publishing, New York, N. Y., 1993

INITIAL DISTRIBUTION LIST

1. Defense Technical Information Center2
Cameron Station
Alexandria, Virginia 22304-6145
2. Library, Code 522
Naval Postgraduate School
Monterey, California 93943-5101
3. Chairman, Code EC.....1
Department of Electrical and Computer Engineering
Naval Postgraduate School
Monterey, California 93943-5121
4. Randy L. Borchartd, Code EC/Bt.....2
Department of Electrical and Computer Engineering
Naval Postgraduate School
Monterey, California 93943-5121
5. Tri T. Ha, Code EC/Ha.....2
Department of Electrical and Computer Engineering
Naval Postgraduate School
Monterey, California 93943-5121
6. Shireen M. Cookson.....2
P.O. Box 154
Edwards AFB, California 93523