

NAVAL POSTGRADUATE SCHOOL Monterey, California



THESIS

PERFORMANCE OF FAST FREQUENCY-HOPPED SELF-NORMALIZED BFSK RECEIVERS OVER RICEAN FADING CHANNELS WITH MULTITONE INTERFERENCE

by

Mary Ellen Green

June 1995

Thesis Advisor:

R. Clark Robertson

Co-Advisor:

Ralph Hippenstiel

Approved for public release; distribution is unlimited.

DTIC QUALITY INSPECTED 1

19960122 107

REPORT DOCUMENTATION PAGE

Form Approved OMB No. 0704-0188

Public reporting burden for this collection of information is estimated to average 1 hour per response, including the time for reviewing instruction, searching existing data sources, gathering and maintaining the data needed, and completing and reviewing the collection of information. Send comments regarding this burden estimate or any other aspect of this collection of information, including suggestions for reducing this burden, to Washington Headquarters Services, Directorate for Information Operations and Reports, 1215 Jefferson Davis Highway, Suite 1204, Arlington, VA 22202-4302, and to the Office of Management and Budget, Paperwork Reduction Project (0704-0188) Washington DC 20503.

1. AGENCY USE ONLY <i>(Leave blank)</i>	2. REPORT DATE June 1995	3. REPORT TYPE AND DATES COVERED Master's Thesis	
4. TITLE AND SUBTITLE PERFORMANCE OF FAST FREQUENCY-HOPPED SELF-NORMALIZED BFSK RECEIVERS OVER RICEAN FADING CHANNELS WITH MULTITONE INTERFERENCE			5. FUNDING NUMBERS
6. AUTHOR(S) Green, Mary E.			
7. PERFORMING ORGANIZATION NAME(S) AND ADDRESS(ES) Naval Postgraduate School Monterey CA 93943-5000			8. PERFORMING ORGANIZATION REPORT NUMBER
9. SPONSORING/MONITORING AGENCY NAME(S) AND ADDRESS(ES)			10. SPONSORING/MONITORING AGENCY REPORT NUMBER
11. SUPPLEMENTARY NOTES The views expressed in this thesis are those of the author and do not reflect the official policy or position of the Department of Defense or the U.S. Government.			
12a. DISTRIBUTION/AVAILABILITY STATEMENT Approved for public release; distribution is unlimited.			12b. DISTRIBUTION CODE
13. ABSTRACT <i>(maximum 200 words)</i> This thesis is an investigation of the performance of noncoherent self-normalized fast frequency-hopped binary frequency shift keying (FFH/BFSK) receivers under conditions of non-negligible thermal noise, band multitone interference and Ricean fading where both the information signal and interference tones are affected by channel fading. Since finding closed form expressions for the most general case of Ricean fading proved difficult, performance was evaluated for special cases of fading. The analysis assumed fixed jamming power and considered two general jamming strategies: jamming a fixed number of frequency-hop slots, and jamming a variable number depending on signal energy per hop. It was found that the degree of fading of the jamming tones had little effect on system performance. It was also found that the most effective jamming strategy depended on the degree of fading of the information signal and on the signal-to-thermal noise power ratio per hop. In general, two-fold diversity yields improved performance with respect to no diversity. When the information signal is Rayleigh faded and the signal power is greater than about 1% of total jamming power, higher diversities perform better than lower diversities. When the signal is Ricean faded, the effect of higher diversities depends on the signal power per hop-to-thermal noise power ratio, the degree of signal fading and on the ratio of signal power-to-total jamming power.			
14. SUBJECT TERMS Spread spectrum communications. Self-normalized receiver. Multitone interference. Fading Channel effects. .			15. NUMBER OF PAGES 100
			16. PRICE CODE
17. SECURITY CLASSIFICATION OF REPORT Unclassified	18. SECURITY CLASSIFICATION OF THIS PAGE Unclassified	19. SECURITY CLASSIFICATION OF ABSTRACT Unclassified	20. LIMITATION OF ABSTRACT UL

NSN 7540-01-280-5500

Standard Form 298 (Rev. 2-89)
Prescribed by ANSI Std. Z39-18 298-102

Approved for public release; distribution unlimited.

**PERFORMANCE OF FAST FREQUENCY-HOPPED SELF-NORMALIZED
BFSK RECEIVERS OVER RICEAN FADING CHANNELS
WITH MULTITONE INTERFERENCE**

Mary Ellen Green
Lieutenant, United States Navy
B.S., United States Naval Academy, 1987

Submitted in partial fulfillment of the
requirements for the degree of

MASTER OF SCIENCE IN ELECTRICAL ENGINEERING

from the

**NAVAL POSTGRADUATE SCHOOL
June 1995**

Author:

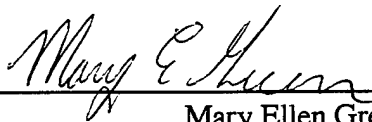

Mary Ellen Green

Approved By:

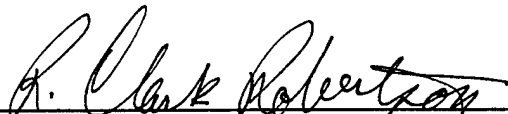

R. Clark Robertson, Thesis Advisor

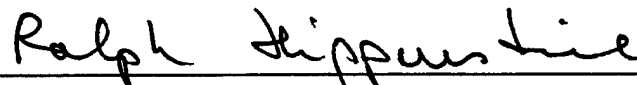

Ralph Hippenstiel, Co-Advisor

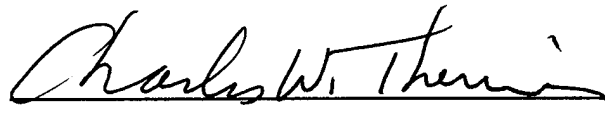

Michael A. Morgan, Chairman,
Department of Electrical and Computer Engineering

ABSTRACT

This thesis is an investigation of the performance of noncoherent self-normalized fast frequency-hopped binary frequency shift (FFH/BFSK) receivers under conditions of non-negligible thermal noise, band multitone interference and Ricean fading where both the information signal and interference tones are affected by channel fading. Since finding closed form expressions for the most general case of Ricean fading proved difficult; performance was evaluated for special cases of fading. The analysis assumed fixed jamming power and considered two general jamming strategies: jamming a fixed number of frequency-hop slots, and jamming a variable number depending on signal energy per hop. It was found that the degree of fading of the jamming tones had little effect on system performance. It was also found that the most effective jamming strategy depended on the degree of fading of the information signal and on the signal-to-thermal noise power ratio per hop. In general, two-fold diversity yields improved performance with respect to no diversity. When the information signal is Rayleigh faded and signal power is greater than about 1% of total jamming power, higher diversities perform better than lower diversities. When the signal is Ricean faded, the effect of higher diversities depends on the signal power per hop-to-thermal noise power ratio, the degree of signal fading and on the ratio of signal power-to-total jamming power.

TABLE OF CONTENTS

I. INTRODUCTION	1
A. BASIC DEFINITIONS AND ASSUMPTIONS	2
1. Spread Spectrum Basics.....	2
2. Binary Frequency-Shift Keying and FH Spread-Spectrum System	4
3. Sources of Interference	6
B. THE SELF-NORMALIZED BFSK RECEIVER	10
II. PERFORMANCE ANALYSIS OF SELF-NORMALIZED FFH/BFSK RECEIVER	13
A. GENERAL EXPRESSIONS FOR PROBABILITY OF BIT ERROR IN A SELF-NORMALIZED FFH/BFSK RECEIVER	13
1. Total Probability of Bit Error.....	13
2. Probability of Bit Error Conditioned on Number of Hops Jammed	14
B. DETERMINING PROBABILITY DENSITY FUNCTIONS FOR DECISION VARIABLES	16
1. Determining the Un-Normalized Branch Outputs (X1k and X2k).....	17
2. Determining PDF of Z1k and Z2k for the General Case of Ricean Fading	20
C. EVALUATING PROBABILITY OF BIT ERROR FOR THE MOST GENERAL CASE OF RICEAN FADING	25
III. PERFORMANCE ANALYSIS OF SELF-NORMALIZED FFH/BFSK RECEIVER: SPECIAL CASES OF FADING.....	27
A. SIGNAL AND JAMMING TONE IN OPPOSITE BRANCHES.....	27
1. Signal and Jamming Tone Both Rayleigh Faded.....	28
2. Signal Rayleigh Faded, Jamming Tone Ricean Faded	29
3. Signal Ricean Faded, Jamming Tone Rayleigh Faded	29
B. SIGNAL AND JAMMING TONE IN SAME BRANCH	30
C. SIGNAL ONLY, NO JAMMER.....	32
1. Signal Rayleigh Faded	33
2. Signal Ricean Faded	33
IV: NUMERICAL ANALYSIS OF SELF-NORMALIZED FFH/BFSK RECEIVER FOR SEVERAL SPECIAL CASES OF FADING.....	35
A. CASES EVALUATED	35
B. PROCEDURE	37

V. NUMERICAL RESULTS AND DISCUSSION	39
A. JAMMING STRATEGIES	39
1. Rayleigh Faded Signals	39
2. Ricean Faded Signal, Rayleigh Faded Jamming Tone	40
B. EFFECTS OF DIVERSITY ON PERFORMANCE.....	44
1. Rayleigh Faded Signal	44
2. Ricean Faded Signal	45
VI. CONCLUSIONS	83
LIST OF REFERENCES	85
LIST OF SYMBOLS	87
INITIAL DISTRIBUTION LIST	91

I. INTRODUCTION

This thesis is an investigation of the performance of a noncoherent self-normalized, fast frequency-hopped binary frequency shift keying (FFH/BFSK) receiver under the conditions of multi-tone interference and Ricean fading.

K. S. Gong showed that frequency-hopped M-ary frequency shift keying (FH/MFSK) non-linear receivers (including self-normalized envelope and square-law detectors) with diversity perform better than conventional receivers in the face of both worst-case partial-band jamming and of multi-tone jamming, when the thermal noise is negligible [Ref. 1]. Miller, Lee, and Kadrichu examined the special case of a FFH/BFSK self-normalized receiver under conditions of no fading and partial-band jamming, taking into account the effects of thermal noise. They concluded that this receiver offers better performance than the conventional FFH/BFSK receiver with diversity, under conditions of partial-band noise jamming [Ref. 2].

R. C. Robertson and T. T. Ha extended the analysis to include performance over Ricean fading channels with partial-band noise jamming. Their investigation shows that, at relatively large signal-to-noise ratios (about 13 dB or more), the self-normalized receiver with diversity appears to neutralize performance degradation due to partial-band noise jamming, and to perform better than the same receiver without diversity, when fading is present. The improvement in performance over that of a self-normalized BFSK receiver with no diversity is particularly marked for heavily-faded channels (received signal having a very small direct path component in comparison to the multi-path components). In general, the self-normalized receiver with diversity shows improved performance relative to that of the same receiver without diversity for relatively large signal-to-noise power ratios over fading channels. The data is more ambiguous for smaller signal-to-noise power ratios [Ref. 3]. This thesis extends the performance analysis of the self-normalized FFH/BFSK receiver to include performance under conditions of channel fading and multi-tone interference instead of partial-band noise jamming when thermal noise is non-negligible.

The inclusion of the effect of thermal noise on performance is critical in the examination of various strategies designed to combat either partial-band noise jamming or multitone jamming. It has been found that the effectiveness of these strategies is related to the level of thermal noise in a non-linear manner. In the analysis presented here, unlike previous analyses of the self-normalized FFH/BFSK receiver, fading is assumed to affect both the signal and the jamming tones (though not the thermal noise component).

A. BASIC DEFINITIONS AND ASSUMPTIONS

1. Spread Spectrum Basics

The term 'spread spectrum' refers to systems in which the transmitted signal energy occupies a bandwidth greater (usually very much greater) than, and independent of, the information bit rate. The spreading of the original information signal is usually accomplished by means of a code independent of the data to be transmitted (accounting for the independence of transmission bandwidth from the information bandwidth). Part of the demodulation process requires correlation of the received signal with a replica of the code signal used to spread the original information signal.[Ref. 4, p.8], [Ref. 5, p. 328]

Three major types of spread spectrum systems are direct-sequence (DS/SS), frequency-hopped (FH/SS), and time-hopped (TH/SS). Hybrid systems also exist. DS/SS systems spread signal energy over a wide bandwidth by remodulating the original signal with a wideband pseudo-random signal [Ref. 4, p. 28]. In TH/SS, transmission time is divided into frames which are subdivided into slots. Data is then transmitted in bursts at slots per frame chosen according to control bits determined by a pseudo-random sequence [Ref. 4, p. 80]. FH systems are discussed in greater detail below. Each type offers advantages under certain conditions. DS/SS systems are less susceptible to interception than are FH/SS. In turn, FH/SS systems are generally more resistant than DS/SS systems to the effects of multi-path fading. [Ref. 4]

In frequency hopping, the data stream is modulated onto a carrier frequency which is switched, or 'hopped,' pseudo-randomly over a set of frequencies in some large

bandwidth, to reduce the probability of interception and to increase the anti-jamming capabilities. Frequency hopped systems may be classified as either slow-or fast- frequency hopped. A slow frequency-hopped system is defined as one in which more than one symbol is transmitted per hop. Systems termed 'fast frequency-hopped' switch carrier frequencies one or more times per symbol interval. If T_h denotes the hopping interval, and T the data bit (or symbol) interval, then in slow frequency hopping, $T_h = LT$, where L is an integer greater than 1. For fast frequency hopping, $T = LT_h$, where L is an integer greater than 0. [Ref. 4, pp 62-64] This frequency switching is one form of transmission diversity, and a signal that hops L times per bit interval is said to use L -fold diversity.

Figure 1 shows a basic block diagram of a frequency-hopped spread-spectrum system of the type considered in this thesis.

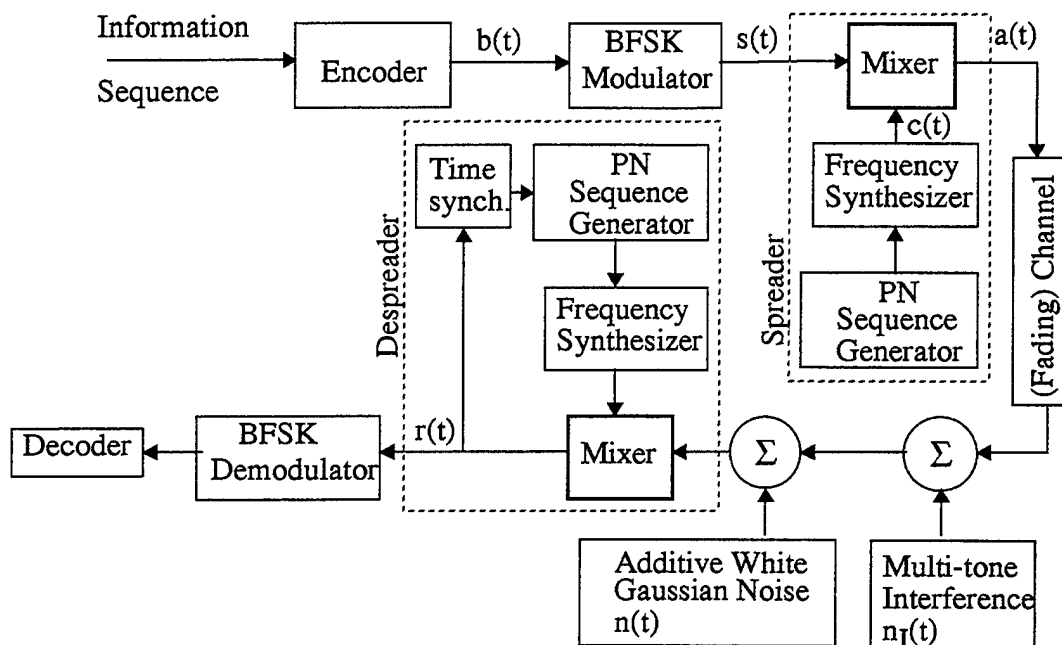

Figure 1: Block diagram of a BFSK Frequency-Hopped spread-spectrum system. After [Ref. 6, p847]

During any given hop, the carrier frequency is selected from the set of J frequencies in the channel bandwidth. The j th carrier frequency is $f_c + j\Delta f_c$, where f_c is the lowest

channel carrier frequency, Δf_c is the frequency separation between adjacent hopping frequencies, and $j= 0, 1, 2... J-1$. A pseudo-noise(PN) sequence generator provides control bits to a frequency synthesizer which in turn generates the particular frequency selected for each hop. [Ref. 4, pp. 62-64]

At the receive side, the signal is dehopped by mixing with a local oscillator controlled by a timing synchronization circuit (to account for delay and phase shifts between the transmit and receive sides) and a PN sequence generator using the same code as the transmit-side spreader [Ref. 5, p. 348]. Clearly, any misalignment or tracking errors in the synchronization process will contribute to decoding errors. This thesis, however, will assume perfect despreading of the received signal in order to consider the effects of channel fading and multi-tone interference in isolation.

2. Binary Frequency-Shift Keying and FH Spread-Spectrum System

The modulation scheme used in FH systems is usually noncoherent (BFSK) or M-ary frequency-shift keying (MFSK), due to the difficulty of maintaining phase coherence between the transmit and receive-side frequency generators [Ref. 6, pp 845-846].

When BFSK is used, the information sequence is encoded as a binary sequence of bits $b(t) \in \{0,1\}$, each bit having duration T . Next, the bit stream is modulated as a BFSK signal $s(t)$ where

$$s(t) = \begin{cases} 2 \cos (2\pi f_0 t + \theta_A), & b(t) = 0 \\ 2 \cos (2\pi [f_0 + \Delta f] t + \theta_A), & b(t) = 1 \end{cases} \quad (1.1)$$

where f_0 is the signal tone corresponding to bit 0, and $f_0 + \Delta f$ is the signal tone corresponding to bit 1 and where Δf is chosen for minimum orthogonal spacing. Since the system dealt with in this thesis is frequency-hopped, the signal hop duration T_h determines the minimum orthogonal spacing, and $\Delta f = 1/T_h$. The phase angle θ_A is modeled as a uniform random variable over the interval $[0,2\pi]$.

The BFSK signal is then modulated onto the carrier frequencies (as in Chapt. I section A.1). Let the carrier be

$$c(t) = \sqrt{2}A \cos [2\pi (f_c + j\Delta f_c) t + \theta_c], j \in 0, 1, \dots, J-1, \quad (1.2)$$

where $\sqrt{2}A$ is the amplitude, f_c is the lowest carrier frequency in the transmission bandwidth, j is determined by the PN sequence, and θ_c is a phase angle modeled as a uniform random variable over the interval $[0, 2\pi]$. The resulting signal, before filtering, is

$$(s_{\text{Trans}}(t) = s(t) c(t)), \quad (1.3)$$

$$s_{\text{Trans}}(t) = \begin{cases} \sqrt{2}A (\cos [2\pi (f_0 + f_c + j\Delta f_c) t + \theta_A + \theta_c] + \cos [2\pi (f_0 - f_c - j\Delta f_c) t + \theta_A - \theta_c]), \text{ bit } 0 \\ \sqrt{2}A (\cos [2\pi (f_0 + f_c + \Delta f_0 + j\Delta f_c) t + \theta_A + \theta_c] + \cos [2\pi (f_0 + \Delta f_0 - f_c - j\Delta f_c) t + \theta_A - \theta_c]), \text{ bit } 1'. \end{cases} \quad (1.4)$$

The resulting signal is filtered to remove either the sum or the difference frequencies (usually, it is high-pass filtered). Assuming high pass filtering, we get the resulting signal:

$$a(t) = \begin{cases} \sqrt{2}A \cos [2\pi (f_0 + f_c + j\Delta f_c) t + \theta_A + \theta_c], \text{ bit } 0 \\ \sqrt{2}A \cos [2\pi (f_0 + f_c + \Delta f_0 + j\Delta f_c) t + \theta_A + \theta_c], \text{ bit } 1'. \end{cases} \quad (1.5)$$

The receiver dehops the received signal by mixing it with the carrier frequencies derived from the pseudo-random sequence shared by the sending and receiving stations, then demodulates and decodes the result to regenerate the original data. [Ref. 6, pp. 845-846]

Fast frequency-hopped BFSK systems may use either constant energy per bit or constant energy per hop. If A is the received signal amplitude, then energy per bit is:

$$E_b = \frac{A^2 T}{2}. \quad (1.6)$$

Let E_h be the energy transmitted per hop. Then for L -fold diversity, constant energy per bit implies T (the bit interval), and thus E_b , are fixed and $E_h = E_b/L$. Conversely, constant

energy per hop requires that T_h and E_h be fixed with the result that $E_b = LE_h$ and $T = LT_h$.

Each method has advantages and drawbacks. Using constant energy per bit ensures that the transmitted bit rate stays constant as diversity increases since the bit duration remains the same while the hop duration decreases. On the other hand, using constant energy per bit will decrease the signal-to-noise power ratio (SNR) per hop as diversity increases. Constant energy per hop slows the data rate but increases the overall SNR as diversity increases since T_h remains constant while T increases. Though the analysis performed later in this thesis assumes constant energy per bit, the equations derived in terms of a fixed E_b are valid with only minor changes for fixed E_h .

3. Sources of Interference

Interference from various sources will cause errors in the regenerated data stream. This thesis will consider the combined effect of three kinds of interference: additive white Gaussian noise ($n(t)$), multi-tone jamming ($n_J(t)$), and multi-path fading of both the desired signal and the jamming tones.

a. Additive White Gaussian Noise (AWGN)

The thermal noise $n(t)$ in the system is modelled as zero-mean additive white Gaussian noise with two-sided power spectral density $N_o/2$. The noise power per hop at the receiver due to AWGN is then

$$\sigma_N^2 = N_o/T_h, \quad (1.7)$$

where T_h is the hop duration and the integrator time constants in the receiver are normalized to $1/T_h$. This thesis assumes that the AWGN interference is not affected by fading.

b. Multi-Tone Jamming

For the purposes of this thesis, the tone jammer is assumed to have sufficient knowledge of the target system, including transmitted signal type and spreading channel

parameters (but not of the exact spreading sequence), to transmit interference tones accurately on some or all of the carrier frequencies. This is a reasonable assumption, since frequency-hopped systems are more susceptible to interception than are direct-sequence systems. Even with a broad channel bandwidth containing a large number of frequency-hop slots, an observer receiving in the channel bandwidth can search for the power spikes at particular frequencies and eventually determine the carrier frequencies being used, if not the PN sequence as well [Ref. 4, p 83]. We also make the secondary assumption that the jammer transmits only one jamming tone per frequency-hop slot. (Recall that each carrier frequency-hop slot contains two separate transmission frequencies, one for each possible data bit.) This strategy is sometimes referred to as band, as opposed to independent, multitone jamming. Independent multitone jamming, where there may be either one or two jamming tones per frequency-hop slot for FH/BFSK, is a somewhat less effective strategy than band multitone jamming [Ref. 7]. Hence, if we assume band multitone jamming, our analysis will give more pessimistic results (from the communicator's standpoint) than will independent multitone jamming. That this is so stands to reason since band multitone jamming requires more sophistication on the part of the jammer than does multitone jamming.

For the case of band multitone jamming, any one jamming tone is either

$$n_{Ji}(t) = \sqrt{2}A_J \cos [2\pi (f_c + i\Delta f_c) t + \theta_J], \quad (1.8)$$

or

$$n_{Ji}(t) = \sqrt{2}A_J \cos [2\pi (f_c + i\Delta f_c + \Delta f) t + \theta_J], \quad (1.9)$$

where θ_J is the phase angle, modeled as a random variable uniformly distributed on $(0, 2\pi)$ and $i=0, 1, 2, \dots, J-1$ and where i is not necessarily equal to the selected signal carrier frequency j . The total tone jamming signal is then

$$n_J(t) = \sum_i^q n_{Ji}(t), \quad (1.10)$$

where q is the number of slots jammed. The slots jammed are not necessarily contiguous.

We assume here that the jammer has a finite amount of power available to jam the spread-spectrum system bandwidth. If there are N_H frequency slots or bins in the bandwidth, and the jammer puts a single interference tone in q of the N_H slots then the probability that a given bin is jammed is (q/N_H) and conversely, the probability that it is not jammed is $(1 - q/N_H)$. Also, if the total available jamming energy is denoted by E_{JT} , then the energy per jammed slot is $E_J = E_{JT}/q$. Some previous work suggests that for a conventional FH/MFSK receiver with a relatively large signal-to-thermal noise power ratio, the jammer's best strategy is to choose the number of slots jammed so that the jamming energy per slot jammed is slightly greater than the signal energy per hop: $E_J = E_h + \epsilon$ where E_h is the signal energy per hop, and ϵ is some small increment [Ref. 5, pp. 597-598]. One of the questions this thesis will address is whether the same strategy is optimum against the self-normalized FFH/BFSK receiver with diversity under the effects of fading channels.

c. Fading Channels

In addition to the effects of thermal noise, RF signals may also suffer interference at the receiver due to the effects of signal scattering and reflection. Instead of travelling in a direct, line-of-sight, path between transmitter and receiver, the signal scatters or reflects off inhomogeneities in the atmosphere, or possibly off objects in the direct path between the transmitter and receiver. Some of the reflected signal may arrive at the receiver along indirect paths, suffering time and phase delay relative to the direct-path signal. The signals received from various paths may combine constructively or destructively at the receiver, and the combining effects may vary with time as the received signal paths change. [Ref. 6, pp. 702-703]

Fading may be characterized by coherence bandwidth and coherence time. The coherence bandwidth describes the frequency range within which signals of varying

frequency are affected similarly by the fading channel. In other words, given two sinusoids of frequencies f_1 and f_2 transmitted over a fading channel with coherence bandwidth $(\Delta f)_C$, if $(f_2 - f_1) \leq (\Delta f)_C$, then the two signals will be suffer approximately the same effects. If $(f_2 - f_1) > (\Delta f)_C$ then the two signals will be affected differently by the fading channel. If the bandwidth of the transmitted signal is less than the coherence bandwidth, the channel is called frequency non-selective; otherwise, it is termed frequency-selective. [Ref. 6, pp. 703-709]

The coherence time refers to the time rate at which the channel characteristics, the attenuation and phase shift imposed on the transmitted signal, change. The channel may be termed slowly-fading if its characteristics remain essentially constant over one or more data symbol durations, and fast-fading otherwise. [Ref. 6, pp. 714-715]

If we assume that the data signal bandwidth (approximately Δf) is much less than the channel coherence bandwidth and that the hop duration is less than the channel coherence time, then the transmission channel each bit experiences is frequency-nonselective and slowly fading. As a result, the effect of the fading channel on any particular transmission of a bit is constant over the bit duration and independent of the bit value. Assuming next that the minimum separation between frequency hop slots is greater than the coherence bandwidth of the channel, we can consider each hop to fade independently. Making these assumptions, we can model each received hop as an independent random variable. The dehopped signal amplitude for any given hop may be modelled as a Ricean random variable, and the signal fading may be characterized by the ratio of signal power received over the direct, or unfaded, path to that received over the diffuse paths [Ref. 3]. Let the received signal be sinusoidal with amplitude $\sqrt{2}A$. Then, if α^2 is the power in the direct path portion of the received signal and $2\sigma^2$ is the power in the diffuse path:

$$A^2 = \alpha^2 + 2\sigma^2, \quad (1.11)$$

and the direct-to-diffuse power ratio is

$$\rho = \frac{\alpha^2}{2\sigma^2}. \quad (1.12)$$

If $\alpha^2 = 0$ (no signal received over the direct path) then $\rho = 0$. This special case is called Rayleigh fading. Conversely, in the unfaded case, $2\sigma^2 = 0$ (no diffuse-path component, all signal received over the direct path) and $\rho \rightarrow \infty$.

B. THE SELF-NORMALIZED BFSK RECEIVER

A block diagram of a self-normalized FFH/BFSK receiver is shown in Figure 2, where $r(t)$ is the dehopped received signal.

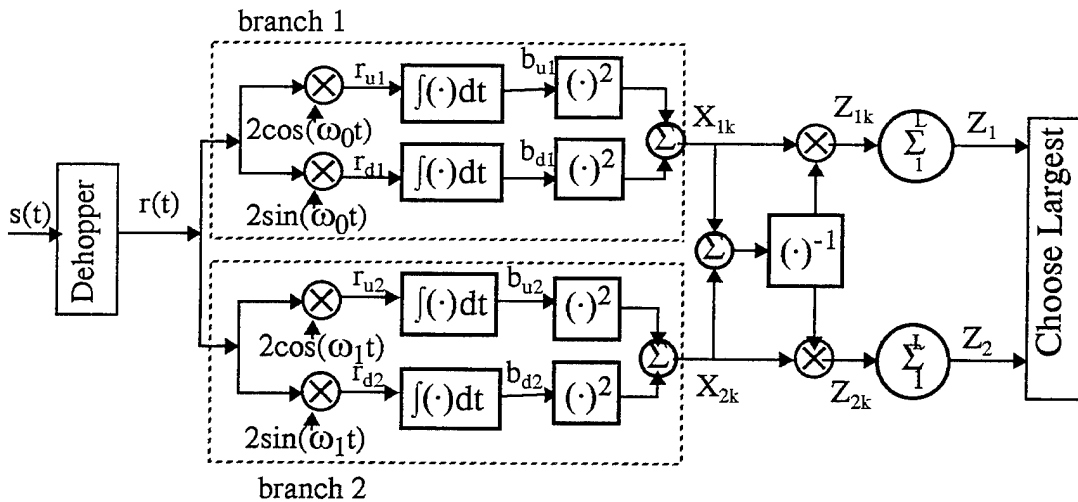

Figure 2: Self-Normalized FFH/BFSK Receiver

The portion of the self-normalized receiver after the dehopper up to the outputs of the two quadratic detector branches is simply a conventional non-coherent BFSK receiver. A conventional BFSK receiver, however, would simply choose the larger of the two outputs X_{1k} or X_{2k} . Consequently, tone jamming on the frequency opposite the transmitted bit can easily cause an erroneous decision. The self-normalized receiver compensates for

the effects of interference on the received signal by multiplying the output of each branch of the BFSK receiver for each received hop by the inverse of sum of the outputs of both receive branches. So: [Ref. 3]

$$Z_{ik} = \frac{X_{ik}}{(X_{1k} + X_{2k})}, \quad i=1,2. \quad (1.13)$$

Some manipulation shows that, though the un-normalized branch outputs X_{1k} and X_{2k} have the range $(0, \infty)$, the normalized outputs Z_{1k} and Z_{2k} have a strictly limited range:

$$Z_{1k} + Z_{2k} = \frac{X_{1k}}{X_{1k} + X_{2k}} + \frac{X_{2k}}{X_{1k} + X_{2k}} = 1, \quad (1.14)$$

and

$$0 \leq Z_{ik} \leq 1. \quad (1.15)$$

The self-normalized signals for each branch of the receiver are no longer independent, then, but are related as follows:

$$Z_{2k} = 1 - Z_{1k} \quad (1.16)$$

Refer to Fig. 2. The random variable Z_i , $i=1,2$ is the sum over L hops of the random variable Z_{ik} . From Eqs. 1.15 and 1.16, it is clear that the summed output of either branch of the receiver can be no greater than L :

$$0 \leq \left(Z_1 = \sum_{k=1}^L Z_{1k} \right) \leq L, \quad (1.17)$$

and

$$Z_2 = \sum_{k=1}^L (1 - Z_{1k}) = L - Z_1. \quad (1.18)$$

In a conventional BFSK receiver with diversity, the output of one or possibly both branches of the receiver during a hop that suffered heavy interference would probably be larger than the branch outputs for a hop with little or no interference. A hop with heavy interference, then, would have more weight in the final decision process. Intuitively, self-

normalization, should reduce the probability of an incorrect decision by ensuring that no hop has a weight greater than one in the final decision variable. A heavily-jammed hop, then, has no greater effect on the outcome of the decision than any of the other hops that are summed to produce the decision variable.

II. PERFORMANCE ANALYSIS OF SELF-NORMALIZED FFH/BFSK RECEIVER

A. GENERAL EXPRESSIONS FOR PROBABILITY OF BIT ERROR IN A SELF-NORMALIZED FFH/BFSK RECEIVER

1. Total Probability of Bit Error

The bit error ratio, or probability of bit error (P_b), is one measure of digital communication system performance. For the FFH/BFSK receiver in Figure 2, the receiver declares '0 sent' if $Z_1 > Z_2$ and '1 sent' otherwise. Intuitively, the actual probability of making an erroneous decision on a given bit interval depends on the amount of interference during that transmission. We assume, as discussed in chapter I section A.3, that the additive white Gaussian noise PSD is constant over the frequency range in question, and that, while each hop fades independently the fading is constant over each hop duration. Once these quantities (signal-to-Gaussian noise ratio, signal-to-jamming intensity ratio, and direct-to-diffuse path ratios for both signal and jamming tones) are fixed, the probability of bit error for any given bit depends on the number of hops that experienced increased narrowband interference. Let $P_b(L,i)$ be the conditional probability of bit error given that i of L hops experience tone interference. The total probability of bit error may be expressed as the weighted sum of all cases of $P_b(L,i)$. The weight of the particular case of $P_b(L,i)$ is the probability that exactly i of L hops experienced interference; this probability, denoted $p_L(i)$, is given by the binomial probability law [Ref. 8, p.62]:

$$p_L(i) = \binom{L}{i} \left(\frac{q}{N_H}\right)^i \left(1 - \frac{q}{N_H}\right)^{L-i}, \quad i = 0, 1 \dots L, \quad (2.1)$$

where $(q/N_H)^i$ is the probability that exactly i of the signal hops are jammed if q of N_H frequency-hop slots are jammed, and $(1 - q/N_H)^{L-i}$ is the probability that exactly $(L-i)$ signal hops are not jammed. The total probability of bit error may then be expressed as [Ref. 3]

$$P_b = \sum_{i=0}^L P_L(i) P_b(L, i), \quad (2.2)$$

and the primary analysis problem is to determine $P_b(L, i)$.

2. Probability of Bit Error Conditioned on Number of Hops Jammed

If a hop is jammed, it may be jammed on the signal branch or on the non-signal branch. Let $P_b(L, i|m)$ be the conditional probability of bit error when i of L hops are jammed, with m of the i jammed hops suffering interference on the signal branch and the remaining $(i - m)$ suffering interference on the non-signal branch. For any given value of i , $P_b(L, i)$ will be the weighted sum of $P_b(L, i|m)$ over all values of m . (This will include all possible combinations of jammed and unjammed hops.) After some experimentation, we can generate expressions for $P_b(L, i)$. When i is an even integer,

$$P_b(L, i) = \frac{1}{2^i} \left(\sum_{m=0}^{(i/2)-1} \left\{ \binom{i}{i-m} [P_b(L, i|i-m) + P_b(L, i|m)] \right\} + \binom{i}{i/2} P_b\left(L, i \mid \frac{i}{2}\right) \right) \quad (2.3)$$

When i is an odd integer, the expression becomes

$$P_b(L, i) = \frac{1}{2^i} \sum_{m=0}^{\lceil i/2 \rceil} \binom{i}{i-m} [P_b(L, i|i-m) + P_b(L, i|m)], \quad (2.4)$$

where $\lceil i/2 \rceil$ means "the integer part of $i/2$."

Now, all we need to do is find an expression for $P_b(L, i|m)$ in terms of the actual branch outputs. From Fig. 2, it is clear that

$$Z_i = \sum_{k=1}^L Z_{ik}, \quad i = 1, 2. \quad (2.5)$$

From Eq. 1.16, $Z_{2k} = 1 - Z_{1k}$ so

$$Z_2 = \sum_{k=1}^L (1-Z_{1k}) = L - Z_1. \quad (2.6)$$

We assume that the FFH/BFSK transmitter, the transmission medium, and the FFH/BFSK receiver form a binary symmetric channel; that is, we assume that the probability that the detector will decide it has received a bit 1 when a bit 0 was actually sent is equal to the probability that the detector will decide it has received a bit 0 when a bit 1 was sent. We assume as well that bit 0 and bit 1 are equiprobable. Given these assumptions, the probability of bit error does not depend on which bit is transmitted. For the purposes of the analysis, we can assume, with no loss of generality, that a bit 0 is transmitted. The probability of bit error when i of L hops are jammed and when m of the jammed hops correspond to a jamming tone on the signal branch and $(i-m)$ of the jammed hops correspond to a jamming tone on the non-signal branch is [Ref. 3]

$$\begin{aligned} P_b(L, i | m) &= \Pr(Z_1 < Z_2 | i, m) \\ &= \Pr(Z_1 < L - Z_1 | i, m) \\ &= \Pr\left(Z_1 < \frac{L}{2} \mid i, m\right). \end{aligned} \quad (2.7)$$

Equation 2.7 shows that the probability of bit error can be determined entirely in terms of the output of the upper branch of the receiver. Hence, to determine the conditional probability of bit error $P_b(L, i | m)$, it is sufficient to find the probability density function (pdf) of Z_1 when i of L hops are jammed with m hops jammed on the signal branch and $(i-m)$ hops on the non-signal branch, $f_{Z_1}(z_1 | i, m)$. We can then integrate as follows [Ref. 3]:

$$P_b(L, i | m) = \int_0^{L/2} f_{Z_1}(z_1 | i, m) dz_1 \quad (2.8)$$

Since Z_1 is the sum of L independent random variables, the pdf of the sum is simply the convolution of the pdfs of the individual random variables. The next several sections

deal with determining the pdfs of the individual random variables. The pdfs will be different for each possible placement of the jamming tone.

B. DETERMINING PROBABILITY DENSITY FUNCTIONS FOR DECISION VARIABLES

Refer to Figure 2. If we assume perfect despreading and timing synchronization, then the received signal $r(t)$ over any given hop interval at the input to the demodulator is the sum of an attenuated version of the transmitted signal $s(t)$ and of some noise $n_T(t)$. As discussed above, we can assume, without any loss of generality, that the original signal transmitted was a bit 0; thus,

$$s(t) = \sqrt{2}a_{ck} \cos(2\pi f_0 t + \theta_A), \quad (2.9)$$

where $\sqrt{2}a_{ck}$, the received signal amplitude on the k^{th} hop, is modeled as a Ricean random variable due to the channel fading effects. The received signal amplitude may, of course, vary from hop to hop. The received signal for the k^{th} hop is

$$r(t) = s(t) + n_T(t), \quad (2.10)$$

where $n_T(t)$ is given as follows:

$$n_T(t) = \begin{cases} n(t), & \text{hop unjammed} \\ n(t) + n_{J_i}(t), & \text{hop jammed.} \end{cases} \quad (2.11)$$

The interference due to tone jamming, $n_{J_i}(t)$, is as defined in Eq. 1.8 and 1.9 except that the received jamming tone amplitude on the k^{th} hop is now $\sqrt{2}a_{Jk}$ and is modeled as a Ricean random variable for the same reasons as is the received information signal amplitude.

There are three possible combinations of signal and jamming tone for any given (despread) hop at the input to the demodulator. If the signal transmitted corresponds to bit 0, the despread jamming tone may correspond to bit 1 (signal and tone in opposite branches of the receiver) or to bit 0 (signal and tone in the same branch of the receiver) or there may be no jamming tone present in that particular received hop. (The assumption that the

jammer puts no more than one tone in each frequency-hop slot, as discussed in Chapter 1, eliminates the possibility that jamming tones are present at both bit 1 and bit 0 frequencies.)

1. Determining the Un-Normalized Branch Outputs (X_{1k} and X_{2k})

a. Signal and Tone in Opposite Branches

The received signal for the k^{th} hop will be

$$r(t) = \sqrt{2}a_{ck} \cos(\omega_0 t + \theta_A) + \sqrt{2}a_{jk} \cos(\omega_1 t + \theta_J) + n(t), \quad (2.12)$$

where $\omega_0 = 2\pi f_0$, corresponding to the angular frequency for bit 0, and

$\omega_1 = 2\pi(f_0 + \Delta f)$, corresponding to the angular frequency for bit 1. We will assume that

the frequency f_0 is an integer multiple of the hop rate, R_h . ($R_h = 1/T_h$.) The frequency

separation $\Delta f = 1/T_h$, as defined in Chapt. I section A.2. For the upper leg of branch 1

after the mixer,

$$r_{u1}(t) = \begin{aligned} & 2\sqrt{2}a_{ck} \cos(\omega_0 t + \theta_A) \cos(\omega_0 t) + \\ & 2\sqrt{2}a_{jk} \cos(\omega_1 t + \theta_J) \cos(\omega_0 t) + n(t) \cos(\omega_0 t). \end{aligned} \quad (2.13)$$

Then, using trigonometric identities and integrating over the hop interval

T_h , we get

$$b_{u1}(t) = \sqrt{2}a_{ck} T_h \cos\theta_A + \frac{\sqrt{2}a_{ck}}{2\omega_0} [\sin(\omega_0 T_h - \theta_A) - \sin\theta_A] + \sqrt{2}a_{jk} \left\{ \frac{\sin[(\omega_1 - \omega_0) T_h + \theta_J] - \sin\theta_J}{\omega_1 - \omega_0} + \frac{\sin[(\omega_1 + \omega_0) T_h + \theta_J] - \sin\theta_J}{\omega_1 + \omega_0} \right\} + N', \quad (2.14)$$

where N' represents the broadband noise term after integration. Given the previous

assumptions about f_0 and Δf , Eq. 2.14 reduces to

$$b_{u1}(t) = \sqrt{2}a_{ck} T_h \cos\theta_A + N'. \quad (2.15)$$

Applying the same procedures to the remaining legs gives the results:

$$b_{d1}(t) = \sqrt{2}a_{ck}T_h \sin\theta_A + N', \quad (2.16)$$

$$b_{u2}(t) = \sqrt{2}a_{Jk}T_h \cos\theta_J + N', \quad (2.17)$$

and

$$b_{d2}(t) = \sqrt{2}a_{Jk}T_h \sin\theta_J + N'. \quad (2.18)$$

Then X_{1k} and X_{2k} are as follows:

$$X_{1k} = (\sqrt{2}a_{ck}T_h)^2 + N, \quad (2.19)$$

and

$$X_{2k} = (\sqrt{2}a_{Jk}T_h)^2 + N, \quad (2.20)$$

where N represents the broadband noise term.

b. Signal and Tone in Same Branch

For this case, the received signal is

$$r(t) = \sqrt{2}a_{ck} \cos(\omega_0 t + \theta_A) + \sqrt{2}a_{Jk} \cos(\omega_0 t + \theta_J) + n(t). \quad (2.21)$$

The output of the upper leg of branch 1 after the mixer is

$$\begin{aligned} r_{u1}(t) = & 2\sqrt{2}a_{ck} \cos(\omega_0 t + \theta_A) \cos(\omega_0 t) + \\ & 2\sqrt{2}a_{Jk} \cos(\omega_0 t + \theta_J) \sin(\omega_0 t) + 2n(t) \sin(\omega_0 t), \end{aligned} \quad (2.22)$$

and the output of the lower leg of the same branch is

$$\begin{aligned} r_{d1}(t) = & 2\sqrt{2}a_{ck} \cos(\omega_0 t + \theta_A) \sin(\omega_0 t) + \\ & 2\sqrt{2}a_{Jk} \cos(\omega_0 t + \theta_J) \sin(\omega_0 t) + 2n(t) \sin(\omega_0 t). \end{aligned} \quad (2.23)$$

After integration, the outputs of the individual legs of the upper branch are:

$$b_{u1}(t) = \sqrt{2}a_{ck}T_h \cos\theta_A + \sqrt{2}a_{Jk}T_h \cos\theta_J + N', \quad (2.24)$$

and

$$b_{d1}(t) = -\sqrt{2}a_{ck}T_h \sin\theta_A - \sqrt{2}a_{Jk}T_h \sin\theta_J + N'. \quad (2.25)$$

Then,

$$\begin{aligned}
X_{1k} = & (\sqrt{2}a_{ck}T_h \cos\theta_A + \sqrt{2}a_{Jk}T_h \cos\theta_J + N')^2 \\
& + (-\sqrt{2}a_{ck}T_h \sin\theta_A - \sqrt{2}a_{Jk}T_h \sin\theta_J + N')^2,
\end{aligned} \tag{2.26}$$

or, after expanding and regrouping terms,

$$X_{1k} = (\sqrt{2}a_{ck}T_h)^2 + 2a_{ck}a_{Jk}T_h^2 \cos\phi + (\sqrt{2}a_{Jk}T_h)^2 + N, \tag{2.27}$$

where $\phi = \theta_A - \theta_J$, the difference between the phase angles of the signal and the jamming tone, θ_C and θ_J , respectively, and is modeled as a uniform random variable over the interval $[0, 2\pi]$. It may be shown by the same methods that

$$X_{2k} = N. \tag{2.28}$$

c. No Jamming Tone Present

In this case, the input to the receiver is

$$r(t) = \sqrt{2}a_{ck} \cos(\omega_0 t + \theta_A) + n(t). \tag{2.29}$$

Then

$$r_{u1}(t) = 2\sqrt{2}a_{ck} \cos(\omega_0 t + \theta_A) \cos(\omega_0 t) + 2n(t) \cos(\omega_0 t) \tag{2.30}$$

and

$$r_{d1}(t) = 2\sqrt{2}a_{ck} \cos(\omega_0 t + \theta_A) \sin(\omega_0 t) + 2n(t) \sin(\omega_0 t). \tag{2.31}$$

The values for $b_{u1}(t)$ and $b_{d1}(t)$ are given by Eqs. 2.15 and 2.16. Equation 2.19 is valid for X_{1k} . It may be shown also that for this case, the output X_{2k} is given by Eq. 2.28.

Table 1 summarizes branch outputs for the three cases.

signal bit	Jamming bit	X_{1k}	X_{2k}
0	1	$(\sqrt{2}a_{ck}T_h)^2 + N$	$(\sqrt{2}a_{Jk}T_h)^2 + N$
0	0	$(\sqrt{2}a_{ck}T_h)^2 +$ $2a_{ck}a_{Jk}T_h^2 \cos \phi +$ $(\sqrt{2}a_{Jk}T_h)^2 + N$	N
0	none	$(\sqrt{2}a_{ck}T_h)^2 + N$	N

TABLE 1: Quadrature Branch Outputs

2. Determining PDF of Z_{1k} and Z_{2k} for the General Case of Ricean Fading

Clearly, the branch outputs X_{1k} and X_{2k} will be random variables with distributions conditioned on $\sqrt{2}a_{ck}$, $\sqrt{2}a_{Jk}$, and ϕ , depending on the case in question. The general form for the pdf at the output of a quadratic detector whose input is a sinusoid plus narrowband (that is, filtered) AWGN with noise power σ_N^2 is as follows [Ref. 9, p. 112]:

$$f_X(x) = \frac{1}{2\sigma_N^2} e^{-\frac{1}{2\sigma_N^2}(x + (\sqrt{2}A))^2} I_0\left(\frac{(\sqrt{2}A)\sqrt{x}}{\sigma_N^2}\right) u(x), \quad (2.32)$$

where I_0 is a modified Bessel function of the first kind and order zero, $u(x)$ is the unit step function, and $\sqrt{2}A$ represents the amplitude of the input sinusoid. As stated above, $\sqrt{2}A$ is modeled as a Ricean random variable. The pdf of such a variable is given as follows [Ref. 9, p. 105]:

$$f_A(a) = \frac{a}{\sigma^2} e^{-\frac{1}{2\sigma^2}(a^2 + \alpha^2)} I_0\left(\frac{a\alpha}{\sigma^2}\right) u(a), \quad (2.33)$$

where, as noted in Chapt. I section A.3, α^2 is the average power of the direct-path signal

component, and $2\sigma^2$ is the average power of the diffuse-path (or multi-path) component.

Finally, for the special case of Rayleigh fading ($\alpha^2=0$):

$$f_A(a) = \frac{a}{\sigma^2} e^{-\frac{a^2}{2\sigma^2}} u(a). \quad (2.34)$$

a. Signal and Jamming Tone in Opposite Branches

From Table 1, the output $X_{1k} = (\sqrt{2}a_{ck}T_h)^2 + N$ and

$X_{2k} = (\sqrt{2}a_{jk}T_h)^2 + N$. Further, let $\overline{a_{ck}^2} = \alpha_c^2 + 2\sigma_c^2$ and $\overline{a_{jk}^2} = \alpha_j^2 + 2\sigma_j^2$, where the

overbar indicates the mean or expected value. Note that the pdfs of X_{1k} and X_{2k} are

conditioned on the random variables representing the received signal and jamming tone

amplitudes, respectively. We indicate this conditioning as follows: the pdf of X_{1k}

conditioned on a_{ck} is denoted $f_{X_{1k}}(x_{1k}|a_{ck})$ and the pdf of X_{2k} conditioned on a_{jk} is

$f_{X_{2k}}(x_{2k}|a_{jk})$. Using Eq. 2.32 for the general form,

$$f_{X_{1k}}(x_{1k}|a_{ck}) = \frac{1}{2\sigma_N^2} e^{-\frac{1}{2\sigma_N^2}(x_{1k} + 2a_{ck}^2)} I_0\left(a_{ck} \frac{\sqrt{2x_{1k}}}{\sigma_N}\right) u(x_{1k}). \quad (2.35)$$

To remove the conditioning on a_{ck} , we integrate as follows [Ref. 8, p. 223]:

$$f_{X_{1k}}(x_{1k}) = \int_{-\infty}^{\infty} f_{X_{1k}}(x_{1k}|a_{ck}) f(a_{ck}) da_{ck}. \quad (2.36)$$

Make substitutions from Eqs. 2.33 and 2.35, and regroup:

$$f_{X_{1k}}(x_{1k}) = \frac{1}{2\sigma_N^2\sigma_c^2} e^{-\frac{1}{2}\left(\frac{x_{1k} + 2\alpha_c^2}{\sigma_N^2 + 2\sigma_c^2}\right)} \times \int_0^\infty a e^{-a^2\left(\frac{1}{2\sigma_c^2} + \frac{1}{\sigma_N^2}\right)} I_0\left(\frac{a\sigma_c\alpha_c}{\sigma_c^2}\right) I_0\left(\frac{a\sigma_c\sqrt{2x_{1k}}}{\sigma_N^2}\right) da_{ck}. \quad (2.37)$$

Evaluating Eq. 2.37 [Ref. 10, p. 718 Eq. 6.633.4], we get

$$f_{X_{1k}}(x_{1k}) = \frac{1}{2(\sigma_N^2 + 2\sigma_c^2)} e^{-\frac{1}{2}\left(\frac{x_{1k} + 2\alpha_c^2}{\sigma_N^2 + 2\sigma_c^2}\right)} I_0\left(\frac{\alpha_c\sqrt{2x_{1k}}}{\sigma_N^2 + 2\sigma_c^2}\right) u(x_{1k}). \quad (2.38)$$

Since X_{2k} has a similar distribution,

$$f_{X_{2k}}(x_{2k}) = \frac{1}{2(\sigma_N^2 + 2\sigma_J^2)} e^{-\frac{1}{2}\left(\frac{x_{2k} + 2\alpha_J^2}{\sigma_N^2 + 2\sigma_J^2}\right)} I_0\left(\frac{\alpha_J\sqrt{2x_{2k}}}{\sigma_N^2 + 2\sigma_J^2}\right) u(x_{2k}). \quad (2.39)$$

If we introduce the auxiliary variable V in addition to the desired random variable Z_{1k} as defined in Eq. 1.13, we can evaluate the pdf $f_{Z_{1k}}(z_{1k})$ in terms of

$f_{X_{1k}}(x_{2k})$ and $f_{X_{2k}}(x_{2k})$ [Ref. 3]. Let

$$V = X_{1k} + X_{2k}. \quad (2.40)$$

Then the transformation can be written

$$\begin{bmatrix} Z_{1k} \\ V \end{bmatrix} = \begin{bmatrix} \frac{1}{V} & 0 \\ 1 & 1 \end{bmatrix} \begin{bmatrix} X_{1k} \\ X_{2k} \end{bmatrix}. \quad (2.41)$$

The Jacobian of the transform matrix in Eq. 2.41 is $J = V^{-1}$. Then

$$f_{Z_{1k}, V}(z_{1k}, v) = \left| \frac{1}{J} \right| f_{X_{1k}, X_{2k}}(x_{1k}=vz_{1k}, x_{2k}=v(1-z_{1k})). \quad (2.42)$$

Since X_{1k} and X_{2k} are independent random variables, their joint pdf $f_{X_{1k}, X_{2k}}(x_{1k}, x_{2k})$ is simply the product of the two individual pdfs. We integrate the expression for

$f_{Z_{1k}, V}(z_{1k}, v)$ over the full range of V to get the desired pdf $f_{Z_{1k}}(z_{1k})$:

$$f_{Z_{1k}}(z_{1k}) = \int_0^{\infty} v f_{X_{1k}}(vz_{1k}) f_{X_{2k}}(v(1-z_{1k})) dv. \quad (2.43)$$

For compactness, let $\beta^2 = \sigma_N^2 + 2\sigma_c^2$ and $\mu^2 = \sigma_N^2 + 2\sigma_J^2$. Then after substituting VZ_{1k} for X_{1k} and $V(1-Z_{1k})$ for X_{2k} , and manipulating the resulting equation, we find

$$f_{Z_{1k}}(z_{1k}) = \frac{1}{4\beta^2\mu^2} e^{-\frac{(\alpha_c^2\mu^2 + \alpha_J^2\beta^2)}{\beta\mu^2}} \times \int_0^{\infty} v e^{-\left(\frac{v}{2}\right) \left[\frac{Z(\mu^2 - \beta^2) + \beta^2}{\beta^2\mu^2}\right]} I_0\left(\frac{\alpha_c\sqrt{2vz_{1k}}}{\beta^2}\right) I_0\left(\frac{\alpha_J\sqrt{2v(1-z_{1k})}}{\mu^2}\right) dv. \quad (2.44)$$

This may be evaluated to be [Ref. 10, p 718, eq.6.633.1]

$$f_{Z_{1k}}(z_{1k}) = \frac{1}{2\beta^2\mu^2} e^{-\frac{(\alpha_c^2\mu^2 + \alpha_J^2\beta^2)}{\beta\mu^2}} \left(\frac{\beta^2\mu^2}{Z_{1k}(\mu^2 - \beta^2) + \beta^2}\right)^2 \times \sum_{m=0}^{\infty} \frac{(m+1)}{m!} \left(\frac{\alpha_c^2\mu^2 Z_{1k}}{\beta^2 [Z_{1k}(\mu^2 - \beta^2) + \beta^2]}\right)^m F\left(-m, -m; 1; \left[\left(\frac{\beta^2\alpha_J}{\mu^2\alpha_c}\right)\left(\frac{1-Z_{1k}}{Z_{1k}}\right)\right]\right). \quad (2.45)$$

The function $F(a, b, c; y)$ is the hypergeometric series [Ref. 10, p. 1039]:

$$F(a, b; c; y) = 1 + \frac{ab}{c \cdot 1} y + \frac{a(a+1)b(b+1)}{c(c+1) \cdot 2!} y^2 + \frac{a(a+1)(a+2)b(b+1)(b+2)}{c(c+1)(c+2) \cdot 3!} y^3 + \dots \quad (2.46)$$

In Eq. 2.45, the first two variables in the hypergeometric series are negative; this guarantees that the series will terminate. Attempts to evaluate Eq. 2.45 over the range of Z_{1k} failed; particularly in the region close to 0 the summation failed to converge. This is probably due to the presence of the quantity $(1 - Z_{1k})/Z_{1k}$ in the fourth variable of the hypergeometric series since the range of Z_{1k} includes 0.

b. Signal and Jamming Tone in Same Branch (Signal and Jamming Tone Transmitted as bit 0)

From Table 1, $X_{1k} = (\sqrt{2}a_{ck}T_h)^2 + (\sqrt{2}a_{jk}T_h)^2 + 2a_{ck}a_{jk}T_h^2 \cos\phi + N$ and $X_{2k} = N$. Using Eq. 2.32 and proceeding as for the first case, we get

$$f_{X_{1k}}(x_{1k}) = \frac{1}{2\sigma_N^2} e^{-\frac{1}{2\sigma_N^2}(x_{1k} + 2[a_{ck}^2 + a_{jk}^2 + 2a_{ck}a_{jk}\cos\phi])} \times I_0\left(\frac{\sqrt{(a_{ck}^2 + a_{jk}^2 + 2a_{ck}a_{jk}\cos\phi)}(2x_{1k})}{\sigma_N^2}\right) u(x_{1k}). \quad (2.47)$$

As before, Eq. 2.33 gives the general form for the pdfs of the random variables a_{ck} and a_{jk} . The phase angle ϕ between the two tones is assumed to be uniformly distributed on $[0, 2\pi]$ so its pdf is simply $1/(2\pi)$. We may remove the conditioning by evaluating the expression

$$f_{X_{1k}}(x_{1k}) = \int_0^{\infty} \int_0^{2\pi} \int_0^{\infty} f_{X_{1k}}(x_{1k}|a_{ck}, a_{jk}, \phi) f_{a_{ck}}(a_{ck}) f_{a_{jk}}(a_{jk}) f_{\phi}(\phi) d\phi da_{ck} da_{jk}. \quad (2.48)$$

There is no closed form solution to this integral, so proceeding with the evaluation for this case requires numerical integration of the above equation.

The expression for the pdf of the other branch is easier to evaluate [Ref. 9, p. 109]:

$$f_{X_{2k}}(x_{2k}) = \frac{1}{2\sigma_N^2} e^{-\left(\frac{x_{2k}}{2\sigma_N^2}\right)} u(x_{2k}). \quad (2.49)$$

c. Signal Only; No Jamming Tone

From Table 1, the output of the branches are $X_{1k} = (\sqrt{2}a_{ck}T_h)^2 + N$ and $X_{2k} = N$. Since the output of branch 1 is identical to that found for the first case, and the

output of branch two is identical to that in the second case, Eqs. 2.38 and 2.49 give the pdfs for X_{1k} and X_{2k} , respectively. Then we follow the same procedure as in Chapt. II, subsection B.2.(a) in order to find the pdf for Z_{1k} :

$$f_{Z_{1k}}(z_{1k}) = \frac{1}{4\beta^2\sigma_N^2} e^{-\left(\frac{\alpha_c^2}{\beta^2}\right)} \int_0^\infty v e^{-\frac{v}{2} \left(\frac{Z_{1k}(\sigma_N^2 - \beta^2) + \beta^2}{\beta^2\sigma_N^2} \right)} I_0 \left(\frac{\alpha_c \sqrt{2vZ_{1k}}}{\beta^2} \right) dv. \quad (2.50)$$

Evaluating this, we obtain [Ref. 10, p. 716 Eq. 6.631.1]

$$f_{Z_{1k}}(z_{1k}) = \frac{\beta^2\sigma_N^2 e^{-\left(\frac{\alpha_c^2}{\beta^2}\right)}}{4 [Z(\sigma_N^2 - \beta^2) + \beta^2]^2} {}_1F_1 \left(2, 1; \frac{\alpha_c^2\sigma_N^2 Z_{1k}}{\beta^2 [Z_{1k}(\sigma_N^2 - \beta^2) + \beta^2]} \right), \quad (2.51)$$

where the expression ${}_1F_1(a, b; y) = \sum_{k=0}^{\infty} \left(\frac{\Gamma(a+k)\Gamma(b)}{k!\Gamma(a)\Gamma(b+k)} \right) y^k$ is the generalized

hypergeometric series [Ref. 10, p. 1045].

C. EVALUATING PROBABILITY OF BIT ERROR FOR THE MOST GENERAL CASE OF RICEAN FADING

In all three cases above, one or both expressions for the pdfs of the branch outputs proved to be difficult to evaluate for the most general case of Ricean fading. Considering several more restricted cases of fading, however, yielded expressions more amenable to evaluation. The next chapter shows the results.

III. PERFORMANCE ANALYSIS OF SELF-NORMALIZED FFH/BFSK RECEIVER: SPECIAL CASES OF FADING

We will consider three special cases of fading: signal and jamming tone both Rayleigh faded ($\rho_c = \rho_J = 0$), signal Rayleigh faded and jamming tone Ricean faded ($\rho_c = 0, \rho_J > 0$), and finally signal Ricean faded and jamming tone Rayleigh faded ($\rho_c > 0, \rho_J = 0$). To simplify the expressions, define the following:

$$\zeta_c = 2\sigma_c^2/\sigma_N^2 \quad (3.1)$$

and

$$\zeta_J = 2\sigma_J^2/\sigma_N^2 \quad (3.2)$$

which are the diffuse-path power-to-thermal noise power ratios for the data signal and tone jamming signal, respectively. Also define

$$\Upsilon_c = \alpha_c^2/\sigma_N^2 \quad (3.3)$$

and

$$\Upsilon_J = \alpha_J^2/\sigma_N^2 \quad (3.4)$$

which are the direct-path power-to-thermal noise power ratio for the data signal and tone jamming signal, respectively.

A. SIGNAL AND JAMMING TONE IN OPPOSITE BRANCHES

From Eqs. 2.38 and 2.39, the pdfs for X_{1k} and X_{2k} in terms of the quantities defined in Eqs. 3.1 through 3.4 are as follows:

$$f_{X_{1k}}(x_{1k}) = \frac{1}{2\sigma_N^2(1+\zeta_c)} e^{-\left(\frac{(x_{1k}/2\sigma_N^2) + \Upsilon_c}{1+\zeta_c}\right)} I_0\left(\frac{\sqrt{2\Upsilon_c(x_{1k}/\sigma_N^2)}}{1+\zeta_c}\right) u(x_{1k}) \quad (3.5)$$

and

$$f_{X_{2k}}(x_{2k}) = \frac{1}{2\sigma_N^2(1+\zeta_J)} e^{-\frac{1}{2}\left(\frac{(x_{2k}/2\sigma_N^2) + \Upsilon_J}{1+\zeta_J}\right)} I_0\left(\frac{\sqrt{2\Upsilon_J(x_{2k}/\sigma_N^2)}}{1+\zeta_J}\right) u(x_{2k}). \quad (3.6)$$

Substituting these expressions into Eq. 2.43, we get a general expression for $f_{Z_{1k}}(z_{1k})$:

$$f_{Z_{1k}}(z_{1k}) = \frac{e^{-\left(\frac{\Upsilon_c}{1+\zeta_c} + \frac{\Upsilon_J}{1+\zeta_J}\right)}}{4\sigma_N^4(1+\zeta_c)(1+\zeta_J)} \int_0^\infty v e^{-\frac{v}{2\sigma_N^2}\left(\frac{Z_{1k}}{1+\zeta_c} + \frac{(1-Z_{1k})}{(1+\zeta_J)}\right)} \times I_0\left(\frac{\sqrt{2\Upsilon_c(vZ_{1k}/\sigma_N^2)}}{1+\zeta_c}\right) I_0\left(\frac{\sqrt{2\Upsilon_J v(1-Z_{1k})/\sigma_N^2}}{1+\zeta_J}\right) dv. \quad (3.7)$$

1. Signal and Jamming Tone Both Rayleigh Faded

For the case of Rayleigh fading, α_c^2 and α_J^2 , (the signal and jamming tone direct path power components, respectively) are both 0. Substituting these values into the expression for $f_{Z_{1k}}(z_{1k})$ in Eq. 3.7, we get:

$$f_{Z_{1k}}(z_{1k}) = \frac{1}{4\sigma_N^4(1+\zeta_c)(1+\zeta_J)} \int_0^\infty v e^{-\frac{v}{2\sigma_N^2}\left(\frac{Z_{1k}}{1+\zeta_c} + \frac{1-Z_{1k}}{(1+\zeta_J)}\right)} dv. \quad (3.8)$$

since $I_0(0) = 1$. This expression may be evaluated as follows [Ref. 10, p. 310 Eq. 3.351.3]:

$$f_{Z_{1k}}(z_{1k}) = \frac{(1+\zeta_c)(1+\zeta_J)}{(\zeta_J - \zeta_c)^2} \times \left[\left(\frac{1+\zeta_c}{\zeta_J - \zeta_c} \right) + Z_{1k} \right]^{-2}. \quad (3.9)$$

2. Signal Rayleigh Faded, Jamming Tone Ricean Faded

In this case, $\rho_c = 0$ and $\rho_J \neq 0$. Equation 3.7 becomes:

$$f_{Z_{1k}}(z_{1k}) = \frac{1}{4\sigma_N^4 (1 + \zeta_c) (1 + \zeta_J)} e^{-\left(\frac{\gamma_J}{1 + \zeta_J}\right)} \times \int_0^\infty \left\{ v e^{-\frac{v}{2\sigma_N^2} \left(\frac{Z_{1k}}{1 + \zeta_c} + \frac{1 - Z_{1k}}{1 + \zeta} \right)} I_0 \left(\frac{\sqrt{2\gamma_J v (1 - Z_{1k}) / \sigma_N^2}}{1 + \zeta_J} \right) dv \right\}, \quad (3.10)$$

which may be evaluated to be [Ref. 10, p. 716 Eq 631.1]:

$$f_{Z_{1k}}(z_{1k}) = \frac{1}{(1 + \zeta_c) (1 + \zeta_J)} e^{-\left[\left(\frac{\gamma_J}{1 + \zeta_J} \right) + \left(\frac{1 + \zeta_c}{1 + \zeta_J} \right) \frac{\gamma_J (1 - Z_{1k})}{(1 + \zeta_c) + Z_{1k} (\zeta_J - \zeta_c)} \right]} \times \left[\frac{Z_{1k}}{1 + \zeta_c} + \frac{1 - Z_{1k}}{1 + \zeta_J} \right]^{-2} \left[1 + \left(\frac{1 + \zeta_c}{1 + \zeta_J} \right) \left(\frac{\gamma_J (1 - Z_{1k})}{(1 + \zeta_c) + Z_{1k} (\zeta_J - \zeta_c)} \right) \right]. \quad (3.11)$$

3. Signal Ricean Faded, Jamming Tone Rayleigh Faded

In this case, $\rho_c \neq 0$ and $\rho_J = 0$. Eq. 3.7 becomes:

$$f_{Z_{1k}}(z_{1k}) = \frac{1}{4\sigma_N^4 (1 + \zeta_c) (1 + \zeta_J)} e^{-\left(\frac{\rho_c}{1 + \zeta_c}\right)} \times \int_0^\infty v e^{-\frac{v}{2\sigma_N^2} \left(\frac{Z_{1k}}{1 + \zeta_c} + \frac{1 - Z_{1k}}{1 + \zeta} \right)} I_0 \left(\frac{\sqrt{2\rho_c (v Z_{1k} / \sigma_N^2)}}{1 + \zeta_c} \right) dv, \quad (3.12)$$

which may be evaluated to be [Ref. 10, p. 716 Eq. 631.1]:

$$f_{Z_{1k}}(z_{1k}) = \frac{e^{-\left(\frac{\Upsilon_c}{1+\zeta_c}\right)}}{(1+\zeta_c)(1+\zeta_J)} e^{-\left(\frac{1+\zeta_J}{1+\zeta_c}\right)\left(\frac{\Upsilon_c Z_{1k}}{(1+\zeta_c)+Z_{1k}(\zeta_J-\zeta_c)}\right)} \times \quad (3.13)$$

$$\left[\frac{Z_{1k}}{1+\zeta_c} + \frac{1-Z_{1k}}{1+\zeta_J} \right]^{-2} \left[1 + \left(\frac{1+\zeta_J}{1+\zeta_c}\right)\left(\frac{\Upsilon_c Z_{1k}}{(1+\zeta_c)+Z_{1k}(\zeta_J-\zeta_c)}\right) \right].$$

B. SIGNAL AND JAMMING TONE IN SAME BRANCH

Considering special cases of fading does nothing to make Eq. 2.48 easier to evaluate. There is still no closed-form solution. Intuitively, though, the probability of bit error when the signal and jamming tone are in the same branch should not be much worse than the probability of bit error when thermal noise is the only source of interference. Ziemer and Peterson suggest this is so for a conventional receiver over unfaded channels [Ref. 5, p. 598]. If the signal and jamming tone are in the same branch and are combined noncoherently, the phase difference may cause destructive or constructive interference between the two; the combined signal may be stronger or weaker than either of the components. The interference tone may thus either reinforce the signal, or attenuate it. If the received information signal and jamming tone amplitudes are identical, and the phase difference between them is $\phi = 180^\circ$ then the two tones will cancel completely; otherwise the effect of the interference will be less detrimental. Since the phase difference between the signal tone and the jamming tone is modeled as a uniform random variable, all possibilities are equally likely.

On the average, then, we can expect that the jamming tone will have much less of an effect on the outcome when it is in the same branch as the signal tone. This has been demonstrated explicitly for FFH/BFSK without diversity [Ref. 11]. Figure 3 illustrates the conditional probability of bit error ($P_b(L=1, i=1)$) vs. the ratio of jamming energy per jamming tone (E_J) to bit energy for a SNR of 13.35dB. The exact result for $P_b(1, 1)$ includes the effect of the information signal tone and jamming tone in the same branch.

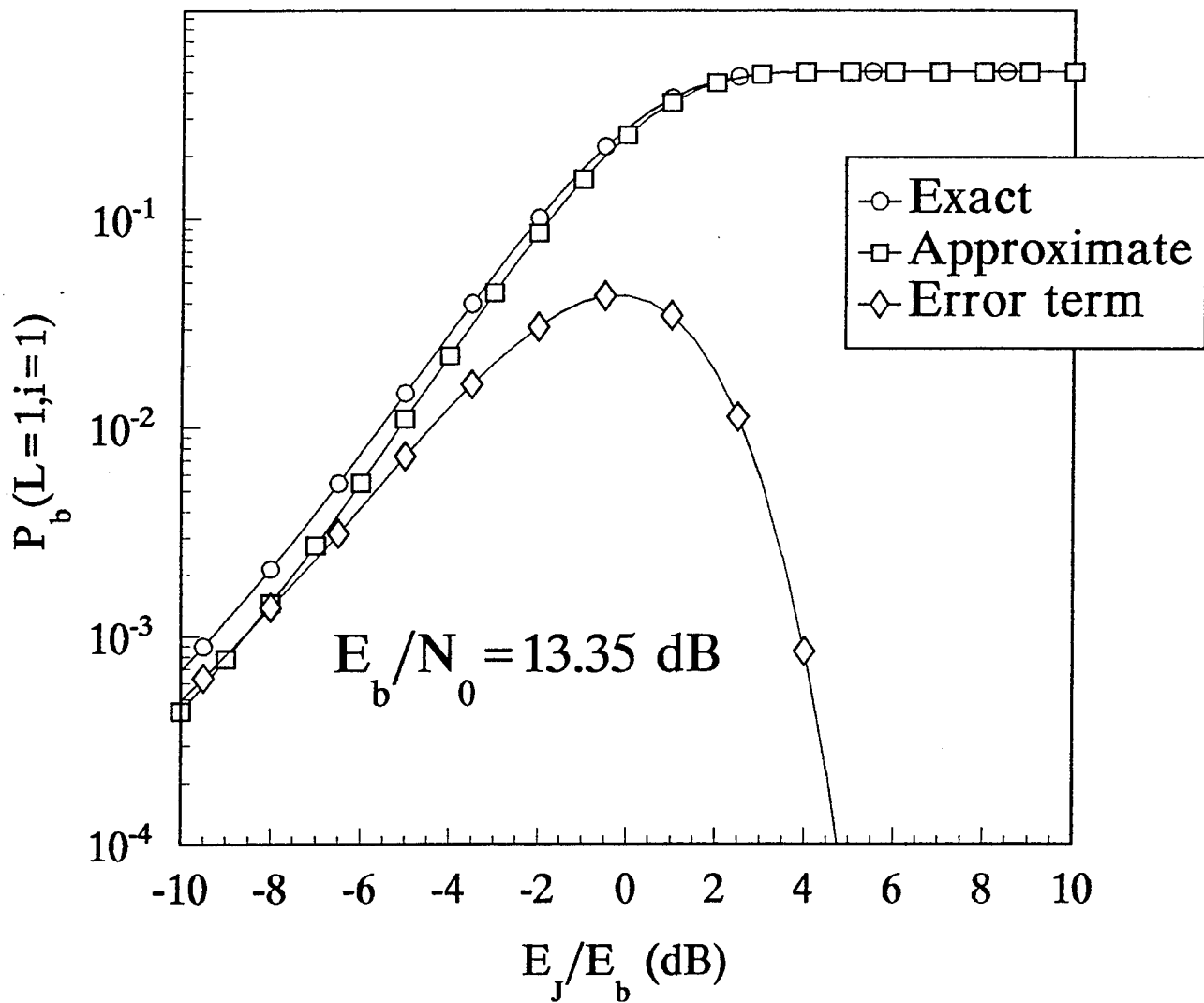

Figure 3: Conditional probability of bit error ($P_b(1, 1)$) vs. jamming tone-to-bit energy ratio for FFH/BFSK with no diversity and with band multitone jamming: exact result, approximate result neglecting contribution of signal and jamming tone in the same branch, and error term. From Ref. [11]

The approximate result is obtained by considering only the effect of having the information signal and the jamming tone in opposite branches. The error term is simply the conditional probability of bit error when the information signal and jamming tone are in the same branch. As expected, the error term is maximum when the jamming tone and information signal have equal amplitude ($(E_J/E_b)_{dB} = 0dB$), and falls off rapidly to either side. The difference between the exact and the approximate result for $(E_J/E_b)_{dB} < 0dB$ is small since on the average the interference will reinforce the information signal to some degree about half the time. For E_J larger than E_b , the difference becomes negligible to non-existent; when the received jamming tone amplitude is much greater than the information signal amplitude, destructive interference caused by the difference in phase angle is no longer important. From Fig. 3, it is clear that, especially when the signal energy is less than the jamming tone energy, the error induced by using the approximate expression for P_b is, at worst, small. Consequently, we will neglect the effects of having the signal and jamming tone in the same branch. Wherever the analysis calls for the pdf for Z_{1k} with the information signal and jamming tone in the same branch, we will substitute the pdf of Z_{1k} when only the information signal tone (and thermal noise, of course) is present. The expression for this pdf is derived in the next section.

C. SIGNAL ONLY, NO JAMMER

Equation 3.5 gives the pdf for X_{1k} . Equation 2.49 gives that of X_{2k} . Substituting these expressions into Eq. 2.43, we get

$$f_{Z_{1k}}(z_{1k}) = \frac{1}{4\sigma_N^4(1+\zeta_c)} e^{-\left(\frac{Y_c}{1+\zeta_c}\right) x} \int_0^\infty v e^{-\frac{v}{2\sigma_N^2} \left(\frac{Z_{1k}}{1+\zeta_c} + (1-Z_{1k})\right)} I_0\left(\frac{\sqrt{2Y_c(vZ_{1k}/\sigma_N^2)}}{1+\zeta_c}\right) dv. \quad (3.14)$$

Since ρ_J does not appear in Eq. 3.14, we need to consider only two special cases of fading: $\rho_c = 0$ and $\rho_c \neq 0$.

1. Signal Rayleigh Faded

In this case, Eq. 3.14 reduces to

$$f_{Z_{1k}}(z_{1k}) = \frac{1}{4\sigma_N^4(1+\zeta_c)} \int_0^\infty v e^{-\frac{v}{2\sigma_N^2} \left(\frac{Z_{1k}}{1+\zeta_c} + (1-Z_{1k}) \right)} dv. \quad (3.15)$$

This expression may be evaluated as follows: [Ref. 10, p. 310 Eq. 3.351.3]

$$f_{Z_{1k}}(z_{1k}) = \frac{(1+\zeta_c)}{[1+\zeta_c(1-Z_{1k})]^2}. \quad (3.16)$$

2. Signal Ricean Faded

In this case, Eq. 3.14 may be evaluated as follows [Ref. 10, p. 716 Eq. 631.1]:

$$f_{Z_{1k}}(z_{1k}) = \frac{\rho_c Z_{1k} + (1+\zeta_c) [1+\zeta_c(1-Z_{1k})]}{[1+\zeta_c(1-Z_{1k})]^3} e^{-\frac{\gamma_c(1-Z_{1k})}{1+\zeta_c(1-Z_{1k})}}. \quad (3.17)$$

In this chapter, we derived the expressions necessary to evaluate the total probability of bit error for several special cases of channel fading. The next chapter addresses the particulars of the actual numerical analysis using the equations derived in this chapter and in Chapt. II.

IV: NUMERICAL ANALYSIS OF SELF-NORMALIZED FFH/BFSK RECEIVER FOR SEVERAL SPECIAL CASES OF FADING

Numerical analysis for this thesis was performed using MATLABTM, an interactive system by The MathWorks, Inc., designed for matrix and vector manipulation and general mathematical computations.

A. CASES EVALUATED

For the purposes of this thesis, we obtained numerical results for diversities of $L = 2, 4, 6$, and for no diversity ($L = 1$). Since analyzing performance for the most general case of Ricean fading proved difficult, we performed the analysis for the three special cases of Ricean fading discussed in Chapt. III.

The number of frequency-hop slots was fixed at $N_H = 1000$; the number of slots jammed (q) was expressed as a percentage of this fixed number. The strategy initially assumed to be “worst-case” is, as discussed in Chapt. I, to choose the number of frequency-hop slots so that the jamming energy per slot jammed is greater than or equal to the signal energy per hop. For this particular strategy, then, the number of frequency-hop slots jammed varies with the ratio of signal energy per hop to total jamming energy. For this strategy, the number of slots jammed for this strategy is related to the signal-to-thermal noise power ratio. The signal-to-thermal noise power ratio is defined in terms of the received signal amplitude, bit duration, and thermal noise power:

$$\frac{S}{\sigma_N^2} = \frac{\overline{a_{ck}^2}}{(N_o/T)} = \frac{E_b}{N_o} \quad (4.1)$$

where S is the average signal power. We choose an appropriate range of values for the signal-to-total jamming tone energy ratio (SJR), E_b/E_{JT} . Then, clearly,

$$E_{JT} = E_b / (\text{SJR}). \quad (4.2)$$

For constant-energy-per-bit systems,

$$E_h = E_b/L, \quad (4.3)$$

with the signal energy per bit a fixed quantity. Then, we can define the assumed worst-case number of slots jammed (q_{wc}) for a particular value of SJR in terms of the total jamming energy and the signal energy per hop:

$$q_{wc} = \begin{cases} 1, & (E_{JT}/E_h) < 1 \\ N, & (E_{JT}/E_h) > N \\ \lceil E_{JT}/E_h \rceil, & \text{otherwise} \end{cases}, \quad (4.4)$$

where $\lceil E_{JT}/E_h \rceil$ means “the integer portion of $\lceil E_{JT}/E_h \rceil$.”

Results were obtained for q_{wc} and for $q = 10, 100, 1000$ (corresponding to 1%, 10%, and 100% jamming of the spread spectrum bandwidth, respectively) in order to determine the actual worst-case strategy.

The equations for the pdf of Z_{Ik} for the various cases of jamming and fading were expressed in terms of the quantities ζ_c , ζ_j , γ_c , and γ_j as defined in Eqs. 3.1 through 3.4. Numerical values for these quantities are obtained once the signal-to-thermal noise power ratio, signal bit energy-to-total jamming energy ratio, and degree of fading for signal tone and jamming tone are fixed. In terms of previously defined quantities,

$$\frac{E_h}{N_o} = \gamma_c + \zeta_c \quad (4.5)$$

and

$$\rho_c = \frac{\gamma_c}{\zeta_c}. \quad (4.6)$$

Solving for γ_c and ζ_c in terms of E_h/N_o and ρ_c , we get

$$\gamma_c = \left(\frac{E_h}{N_o} \right) \left(\frac{\rho_c}{1 + \rho_c} \right) \quad (4.7)$$

and

$$\zeta_c = \left(\frac{E_h}{N_o} \right) \left(\frac{1}{1 + \rho_c} \right). \quad (4.8)$$

Following a similar procedure, we may solve for Υ_J and ζ_J in terms of E_J/N_o and ρ_J after recognizing that the ratio of jamming power per jammed slot to noise power may be expressed in terms of known quantities as follows:

$$\frac{E_J}{N_o} = \left(\frac{(E_b/N_o)}{(E_b/E_{JT})} \right) \left(\frac{1}{q} \right) \quad (4.9)$$

where q is, as before, the actual number of bins jammed.

Initially, results were obtained for a signal-to-thermal noise power ratio of 13.35dB, which was large enough allow evaluation at reasonable diversity levels using the constant energy per hop assumption. The case of a Ricean faded signal and Rayleigh faded jammer was also evaluated at a signal-to-thermal noise power ratio (SNR) of 16.35dB.

B. PROCEDURE

As discussed in previous chapters, the decision variable Z_1 is the sum of L independent random variables, expressions for whose pdfs we derived in Chapter III. The pdf of Z_1 (for $L > 1$) is the convolution of the pdfs of the individual random variables. Since the individual random variables have a strictly limited range (recall Eq. 1.15 and 1.16), their pdfs also have a limited range, which makes the numerical evaluation of the convolution fairly straightforward. We begin the process of obtaining the pdf $f_{Z_1}(z_1|i, m)$ by evaluating, at fixed intervals over their range, the expressions obtained in chapter III for the pdf of Z_{1k} for the particular cases of interference and fading. This provides a sampled version of each individual pdf.

For $L = 1$, we evaluate the expressions for the individual cases of jamming directly. For $L = 2$, we obtain $f_{Z_1}(z_1|i, m)$ by discrete convolution of the sampled versions of the individual pdfs for the particular case of fading under consideration.

For the larger values of diversity, however, direct numerical convolution, with the repetitious shifting, and integration involved, becomes unacceptably slow. Brigham [Ref. 12] shows that the discrete Fourier transform (DFT) may be used to approximate the results of the continuous convolution of two waveforms of finite duration with an error no worse than that introduced by rectangular integration [Ref 12, pp. 113-114] and with much improved computational efficiency [Ref 12, pp. 201-202].

After obtaining a vector of values representing a sampled version of $f_{Z_1}(z_1|i, m)$ by one of the two methods above, we obtained a numerical value for the conditional probability of bit error $P_b(L, i|m)$ by evaluating Eq. 2.8 using Simpson's Rule to approximate the continuous integral. The algorithm used to evaluate the integral was adapted from one presented in Davis and Rabinowitz' *Methods of Numerical Integration* [Ref. 13, pp. 492-493]. Upon obtaining values for all cases of $P_b(L, i|m)$, we find P_b by evaluating Eq. 2.3 or 2.4 as appropriate to get $P_b(L, i)$ for each value of i , then using the values obtained for $P_b(L, i)$ in Eq. 2.2 to get P_b .

The results may be checked asymptotically for large values of E_b/E_{JT} using expressions developed for conventional orthogonal noncoherent BFSK receivers with diversity over fading channels [Ref. 6, Ref. 14]. When the information signal power is very large compared to the total jamming tone power, the tone jammer has a negligible effect on the error rate. Since the primary cause of error is now thermal noise, which is assumed to be distributed evenly over all hops, the performance of the self-normalized receiver will approach that of the conventional receiver.

V. NUMERICAL RESULTS AND DISCUSSION

A. JAMMING STRATEGIES

To establish a baseline to consider the effects of different diversities on performance when the system experiences fading and multitone jamming, we need to determine the actual worst-case jamming strategy for each combination of diversity and channel fading. (For the purpose of this discussion, "worst-case" refers to the jamming strategy that causes the greatest performance degradation in the receiver.) As discussed in the preceding chapter, two general categories of jamming strategies were considered: jamming a fixed number of frequency-hop slots, and varying the number of slots jammed to ensure that the jamming energy per slot jammed is greater than or equal to the signal energy per hop. It appears, in general, that the most detrimental jamming strategy when the signal is Rayleigh faded differs from that when the signal is not Rayleigh faded.

1. Rayleigh Faded Signals

As stated in Chapt. I, several previous analyses of various communication systems under conditions of band multitone jamming over unfaded channels with negligible thermal noise suggest that the worst-case jamming strategy is to divide the available jamming power so that the jamming power per jammed bin either equals or exceeds the signal energy per hop by some small amount. (This strategy will be referred to as " q_{wc} .") As shown in Figs. 4, 5, and 6 for $L=2, 4, 6$, respectively, with a $SNR = 13.35\text{dB}$, and Rayleigh fading of both the signal tone and jamming tone, the strategy of jamming 100% of frequency-hop slots (which will be referred to as " $q_{100\%}$ ") proves to have a more negative effect on receiver performance than does the q_{wc} strategy. Note that the difference between the q_{wc} strategy and the $q_{100\%}$ strategy grows more pronounced as diversity increases. The next set of figures shows performance when the signal is still Rayleigh faded and the jamming tone experiences Ricean fading with $\rho_J = 10, 100$, for various diversities. Figures 7 and 8 show the results for $L = 2$; Figs. 9 and 10 show the results for $L = 4$. Clearly, the $q_{100\%}$

strategy is still the most detrimental, from the receiver's standpoint. For signal-to-total jamming energy ratios greater than unity ($E_b/E_{JT} > 0\text{dB}$), however, there is little difference between the performance of the various strategies. Results obtained for receiver performance for an SNR of 16.35dB showed the same trends, and were omitted for the sake of brevity.

In later graphs and discussions, we use worst-case jamming strategy for each case of fading and diversity as a basis for comparison. As shown in this subsection, for the case of a Rayleigh faded signal tone and any diversity, the $q_{100\%}$ strategy has the most detrimental effect on receiver performance of those jamming strategies considered. As will be shown in the next subsection, when the signal is Ricean faded instead, the $q_{100\%}$ is not always the worst-case strategy.

2. Ricean Faded Signal, Rayleigh Faded Jamming Tone

When the signal experiences Ricean fading in general (excluding the special case of Rayleigh fading), the worst-case jamming strategy depends on the degree of fading and the order of diversity. We would expect that as the signal becomes less faded or the SNR becomes larger, thus becoming closer to the situations dealt with in previous research (unfaded channels, negligible thermal noise), the q_{wc} strategy will be closer to being the actual worst case. To investigate the trends, if any, we will look at performance for diversities of $L = 1, 2, 4, 6$, and for two degrees of fading of the information signal, $\rho_c = 10, 100$. The parameter $\rho_c = 10$ represents moderate fading; $\rho_c = 100$ represents something much closer to unfaded.

Since the energy per bit is fixed, as diversity increases the ratio of signal power per hop to noise power will decrease. For L -fold diversity and some fixed bit SNR, the signal power per hop-to-thermal noise power is given by

$$(E_h/N_o)_{\text{dB}} = 10\log\left(\frac{E_b/L}{N_o}\right) = \text{bit SNR} - 10\log(L) \quad (5.1)$$

where “log” is the logarithm base 10. With two-fold diversity, $(E_h/N_o)_{dB}$ is 3 dB less than the SNR; four-fold diversity means the drop is 6 dB. For six-fold diversity, the drop is about 7.8 dB. For a fixed SNR, then, we expect that increasing diversity will drive the actual worst-case jamming strategy from q_{wc} to $q_{100\%}$, provided that E_h/N_o is strong enough to outweigh noncoherent combining losses. In addition, for the self-normalized receiver in general, we expect increasing diversity to drive the actual worst case jamming strategy from q_{wc} to $q_{100\%}$ provided the hop SNR (E_h/N_o) is large enough to outweigh noncoherent combining losses.

Figures 11 and 12 show probability of bit error for an SNR of 13.35dB, no diversity ($L = 1$), and $\rho_c = 10, 100$, respectively. Note that, for both degrees of fading, the q_{wc} strategy has the most negative effect on receiver performance.

Figures 13 and 14 show the results for $\rho_c = 10, 100$, respectively, with a bit SNR of 13.35 dB, and $L = 2$. Though the q_w strategy is the actual worst-case strategy over some parts of the range of E_b/E_{JT} for both degrees of fading, it is no longer the actual worst-case one over the entire range. No particular strategy clearly has the most negative effects on receiver performance across the entire range of E_b/E_{JT} .

Figures 15 and 16 show the results for the same bit SNR, a diversity of $L = 4$, and $\rho_c = 10, 100$, respectively. We see, as expected, that since the thermal noise power is larger with respect to the signal power per hop than for two-fold diversity, $q_{100\%}$ tone jamming has become the worst-case strategy. Note, though, that as ρ increases (the amount of fading decreases), the difference between the $q_{100\%}$ strategy and the q_{wc} strategy decreases.

Figures 17 and 18 illustrate performance for an SNR of 13.35dB, a diversity of $L = 6$, and $\rho_c = 10, 100$, respectively. By comparing the results for a fixed bit SNR and degree of fading, we can see that for a fixed SNR the worst-case jamming strategy changes,

as predicted, from q_{wc} to $q_{100\%}$ as diversity increases. Figures 11, 13, 15, and 17 display performance for an SNR of 13.35dB, $\rho_c = 10$, and $L = 1, 2, 4, 6$, respectively. When $L=1$ (Fig, 11), the q_{wc} strategy is the most detrimental. As diversity increases, other strategies begin to have a more negative effect on receiver performance than does the q_{wc} strategy. Finally, for $L=6$, the $q_{100\%}$ strategy is the actual worst-case one. Figures 12, 14, 16, and 18 which give performance for the same SNR, $\rho_c = 100$, and the same range of diversities, show the same trend.

We also checked the results for an bit SNR of 16.35 dB to see if the trend of performance continued as expected. We expected that at the higher signal power levels the q_{wc} strategy would be the more detrimental one over a broader range of diversity than for the lower SNR. Figures 19 and 20 display results for a bit SNR of 16.35dB, no diversity, and $\rho_c = 10, 100$, respectively. As expected, the q_{wc} strategy is the worst-case one.

Figures 21 and 22 show the results for a bit SNR of 16.35 dB, $L = 2$, and $\rho_c = 10, 100$, respectively. (On Fig. 22, the sharp corner on the plot of q_{wc} at about the 0dB point results from the way the number of slots jammed is calculated; at that point, there is a sharp, temporary increase in the jamming energy per jammed slot, due to a sharp drop in the number of bins jammed.) Compare Fig.13 with Fig. 21. For the smaller SNR (Fig. 13), no strategy is clearly the most adverse across the entire range of E_b/E_{JT} , but the q_{wc} strategy is as effective in degrading receiver performance as the others when $E_b/E_{JT} > \sim -20\text{dB}$. For the same diversity and degree of fading, and the higher SNR (Fig. 21), the q_{wc} strategy is, in fact, the most effective one by a very narrow margin for $E_b/E_{JT} > -5 \text{ dB}$. Compare Fig. 14 with Fig. 22 to see what happens as the information signal SNR (E_b/N_o) increases when channel fading is less severe. For a small range of E_b/E_{JT} , the 1% jamming strategy has a more adverse effect on receiver performance than

does the q_{wc} for both values of SNR. The q_{wc} strategy, however, has a distinctly more adverse effect for large E_b/E_{JT} when the signal-to-thermal noise power ratio is greater.

The pattern continues at higher diversity levels: Figs. 23 and 24 show performance for a bit SNR = 16.35 and $L = 4$. Contrast the moderately-faded signal tone performance (Fig. 23) with the less-faded signal performance (Fig. 24). As the degree of fading decreases (as ρ_c increases), the q_{wc} strategy becomes as effective or slightly more effective in degrading receiver performance than the others across the range of E_b/E_{JT} .

Figures 25 and 26 show performance for the same SNR, $L = 6$, and $\rho_c = 10, 100$, respectively. When the degree of fading is moderate, the $q_{100\%}$ strategy causes the greatest performance degradation; when the fading is less severe, the q_{wc} strategy becomes the worst from the receiver's viewpoint. Compare Figs. 19, 21, 23, and 25, which show performance for an SNR of 16.35dB, $\rho_c = 10$, and $L = 1, 2, 4, 6$, respectively. When $L=1$ (Fig. 19), the q_{wc} strategy clearly causes the greatest performance degradation over the entire range of E_b/E_{JT} . As diversity increases, other strategies are more detrimental than the q_{wc} strategy across more parts of the range of E_b/E_{JT} . Now, compare Figs. 20, 22, 24, and 26, which show performance for the same SNR, $\rho_c = 100$, and $L = 1, 2, 4, 6$, respectively. The information signal is less faded here, and the q_{wc} strategy remains, in general, the most adverse one from the receiver's viewpoint as diversity increases (though some strategies are worse for limited ranges with the lower diversities). This result is as expected; because the SNR is larger and the signal closer to unfaded, the conditions are closer to those assumed in previous research which predicts that the q_{wc} strategy will be the most detrimental to transmitter system performance.

The general pattern shows that, for large hop SNRs and for weakly faded signals, the q_{wc} strategy is indeed the most detrimental to receiver performance. Since the analysis predicting that the q_{wc} jamming strategy would have the most adverse effect on receiver

performance assumed unfaded channels and negligible thermal noise, this trend is not surprising. The larger the hop SNR and the closer to unfaded the signal is, the more the channel parameters resemble the assumptions of the previous analysis. As fading or diversity increases for a given bit SNR, the $q_{100\%}$ jamming strategy becomes the more detrimental one.

In summary, when the signal tone is Rayleigh faded, the $q_{100\%}$ strategy is the most adverse of those considered. When the signal is Ricean faded, in general, the worst-case strategy depends on the signal strength with respect to thermal noise levels, on the level of diversity, and on the degree of fading. The closer the information signal channel is to unfaded and the larger the hop SNR is, the closer the q_{wc} strategy is to being the actual worst-case. Having determined the worst-case jamming strategy for the cases of fading considered, we will examine the effects of diversity under conditions of worst-case jamming.

B. EFFECTS OF DIVERSITY ON PERFORMANCE

Comparisons in this section are based on worst-case performance (the performance under actual worst-case jamming for the particular level of diversity and fading) as determined in the preceding section. Recall that for Rayleigh faded signals, worst case jamming is the $q_{100\%}$ strategy, but for Ricean faded signals with large signal-to-thermal noise power ratios and low diversity, or for those signals that were only lightly faded, the q_{wc} strategy tends to be the more effective one.

1. Rayleigh Faded Signal

Figure 27 shows the probability of bit error for a bit SNR of 13.35dB, diversity $L = 1, 2, 4, 6$, and $\rho_c, \rho_J = 0$. Figures 28 and 29 show the probability of bit error for the same bit SNR and diversity levels with the signal tone affected by Rayleigh fading, and the jamming tones affected by different levels of Ricean fading. What is surprising is that the degree of fading of the jamming tone has very little effect on system performance.

Close comparison of Figs. 27, 28, and 29 shows that the probability of bit error is slightly greater over the range $E_b/E_{JT} > \sim -15\text{dB}$ when $\rho_J = 100$ than when $\rho_J = 10$ or when both information signal and jamming tones are Rayleigh faded, but the difference is small.

Also note that two-fold diversity offers improved performance over no diversity for the entire range of E_b/E_{JT} over which we chose to evaluate probability of bit error. For an SNR of 13.35dB and $E_b/E_{JT} < \sim -15\text{dB}$, higher levels of diversity offer no advantage and, in fact, degrade performance compared to the probability of bit error at $L = 2$.

We also plotted results for a bit SNR of 16.35dB in order to examine performance for large signal-to-thermal noise power ratios. Figure 30 shows probability of bit error for a bit SNR of 16.35dB, Rayleigh fading of both signal and jammer, and $L = 1, 2, 4, 6$. Note that, in contrast to the performance at SNR = 13.35dB, diversity offers improved performance relative to no diversity for $L=2,4$ over the entire range of E_b/E_{JT} . Figures 31 and 32 display results for a bit SNR of 16.35dB, $L = 1, 2, 4, 6$, and Ricean fading of the jamming tone ($\rho_J = 10, 100$, respectively) with the information signal Rayleigh-faded. Note that, as for the smaller SNR, increased diversity actually degrades performance on a certain range of E_b/E_{JT} . For $E_b/E_{JT} > -20\text{dB}$; however, increasing diversity improves performance.

2. Ricean Faded Signal

Figure 33 shows the probability of bit error for diversity $L = 1, 2, 4, 6$, a Rayleigh-faded tone jammer and Ricean fading of the signal ($\rho_c = 10$), and an SNR of 13.35dB. Figure 34 shows probability of bit error for the same SNR and the same diversities but a different degree of fading on the information signal ($\rho_c = 100$). The worst case jamming strategies are different for each level of diversity and fading and may be identified by examining Figs. 11, 13, 15, and 17 (for $\rho_c = 10$) and Figs. 12, 14, 16, and 18 (for $\rho_c = 100$). For $\rho_c = 10$ and $L = 1, 2$, the actual worst case strategy plotted was the q_{wc}

strategy. For the same degree of fading and $L = 4, 6$, the $q_{100\%}$ tone jamming was worst-case. For $\rho_c = 100$, the jamming strategy for $L = 2, 4, 6$ was the $q_{100\%}$ strategy, except for a narrow range of values of E_b/E_{JT} for diversity $L = 2$, for which the best strategy is to jam a fixed number (1%) of frequency hop-slots. The line for $\rho_c = 100$, $L = 2$ is therefore a piecewise combination of the two strategies. For the case of no diversity, the q_{wc} jamming strategy is still the most detrimental.

From Fig. 33, we see that when the signal is moderately faded ($\rho_c = 10$) a diversity of $L = 2$ still offers at worst the same probability of bit error as no diversity and offers improved performance over no diversity for an SJR as small as $E_b/E_{JT} > \sim -25\text{dB}$. When $\rho_c = 100$, two-fold diversity still offers equal or better performance than does no diversity until the signal energy is about three times greater than the total jamming energy ($E_b/E_{JT} > \sim 5\text{dB}$). It appears that, in general, when the information signal experiences Ricean fading (excluding the special case of Rayleigh fading), two-fold diversity gives better receiver performance than higher levels of diversity do. Also, two-fold diversity usually offers improved performance over that afforded by no diversity.

To confirm the trends, we present the results for a bit SNR of 16.35dB. Figures 35 and 36 illustrate the probability of bit error for a bit SNR of 16.35dB, Ricean fading of the information signal ($\rho_c = 10, 100$, respectively), and Rayleigh faded jamming tones. (Note the larger range of E_b/E_{JT} over which the probability of bit error is evaluated. This is done to show that, just as for the smaller SNR and other special cases of fading evaluated, the improvement in system performance, measured in probability of bit error, levels off at some point.) The actual worst case strategy can be seen from Figs. 19, 21, 23, and 25 (for $\rho_c = 10$) and from Figs. 20, 22, 24, and 26 (for $\rho_c = 100$). For $L=2$ and for $L = 4$ with $\rho_c = 10$, the actual worst case strategy is a piecewise combination of two strategies. For

$L=1$, and for $L = 4, 6$ with $\rho_c = 100$, q_{wc} is the worst case strategy. For $\rho_c = 10$, $L = 6$, the $q_{100\%}$ strategy is the most effective.

Compare Figs. 33 and 35, which illustrate the effect of actual worst case jamming on performance for $\rho_c = 10$, $\rho_J = 0$ and bit SNRs of 13.35dB and 16.35dB, respectively. Both graphs show that when bit energy is sufficiently large with respect to the total jamming energy, diversity begins to improve performance. For the smaller bit SNR (Fig. 33), for $E_b/E_{JT} > \sim 12\text{dB}$, four-fold diversity performs better than two-fold, which in turn performs better than no diversity. Six-fold diversity still offers no performance advantage. The plot for the larger bit SNR (Fig. 35) shows almost the same effect, except that six-fold diversity offers an advantage over four-fold for E_b/E_{JT} sufficiently large. Compare Figs. 34 and 36, which show performance under actual worst case jamming for $\rho_c = 100$, $\rho_J = 0$ and bit SNRs of 13.35dB and 16.35dB, respectively. It is clear that when the information signal becomes large with respect to the total jamming energy ($E_b/E_{JT} > \sim 5\text{dB}$ for a bit SNR of 13.35dB, $E_b/E_{JT} > \sim 15\text{dB}$ for the larger bit SNR), diversity actually degrades receiver performance. It may be that, when the signal is close to unfaded and signal energy is large in comparison to the jamming energy, the noncoherent combining losses become a dominant cause of error. The results are more ambiguous for smaller ratios of E_b/E_{JT} . For the smaller bit SNR, two-fold diversity gives better performance than four-fold (except for a small range of E_b/E_{JT}) and six-fold diversity over the entire range evaluated. For the larger bit SNR, there is a range of E_b/E_{JT} on which increased diversity yields improved performance (though the difference in performance between four-fold and six-fold diversity is small).

If the transmitter knows nothing about the channel fading conditions or the jammer's strength and strategy, an effective compromise strategy is to use smaller diversities in preference to larger ones. Using the smaller diversity will provide improved performance over no diversity almost all the time and will frequently provide improved

performance over higher levels of diversity. If the transmitter knows that the information signal channels are heavily faded and the available transmitter power is more than about 1% of the available jamming power, higher diversities may be advantageous.

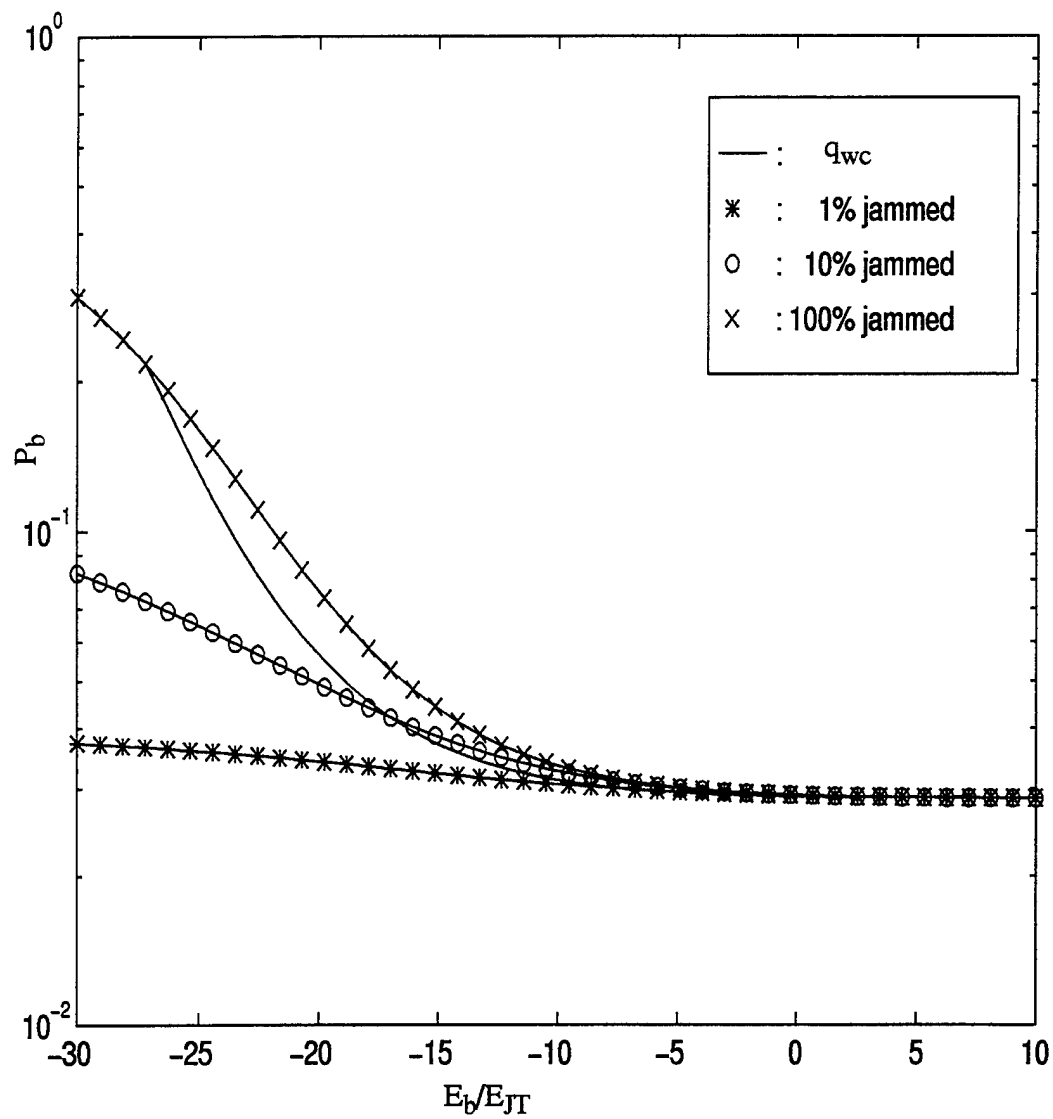

Figure 4: Probability of bit error for Rayleigh fading of both information signal and jamming tones, $L=2$, and $E_b/N_o = 13.35$ dB, for several jamming strategies.

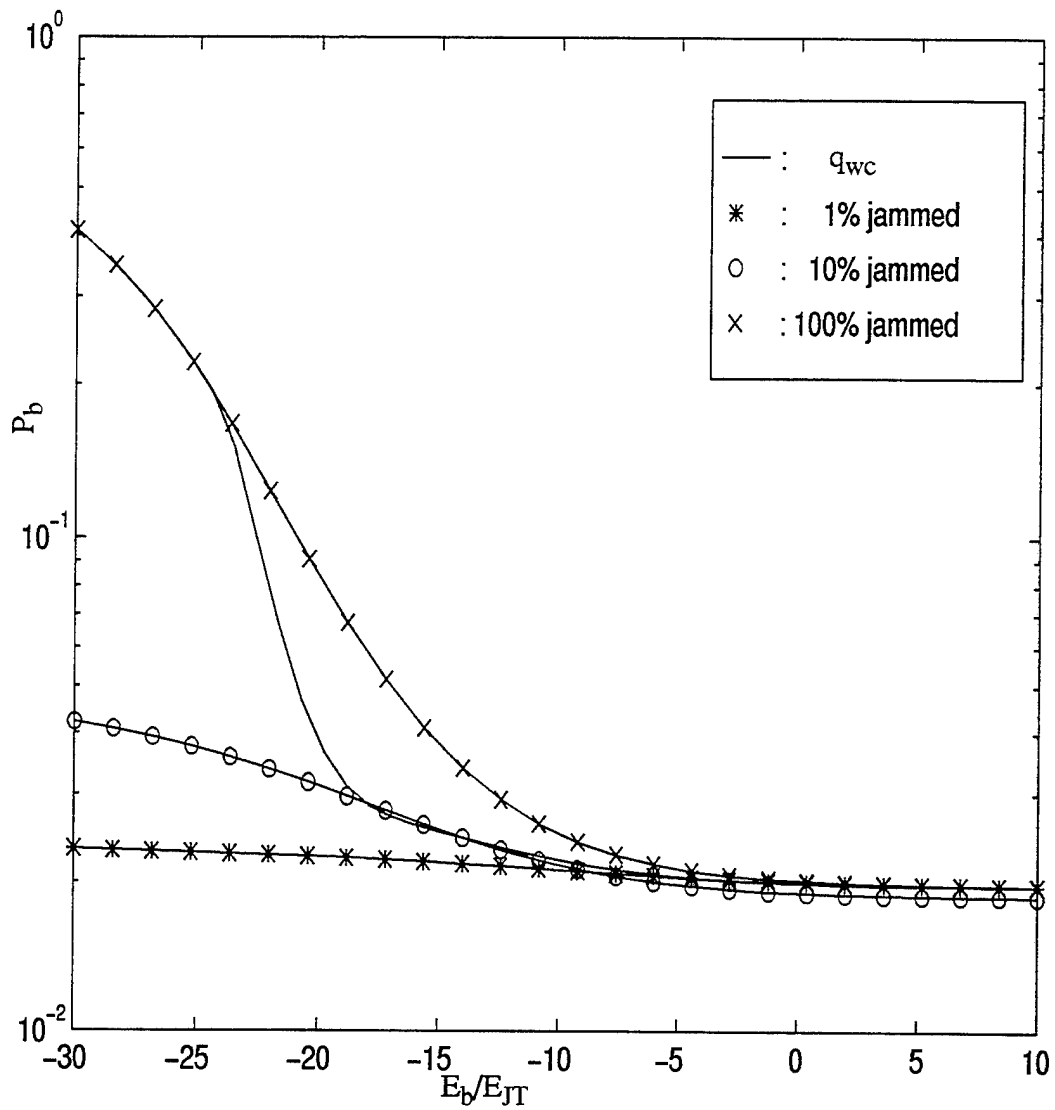

Figure 5: Probability of bit error for Rayleigh fading of both information signal and jamming tones, $L=4$, and $E_b/N_0 = 13.35$ dB, for several jamming strategies.

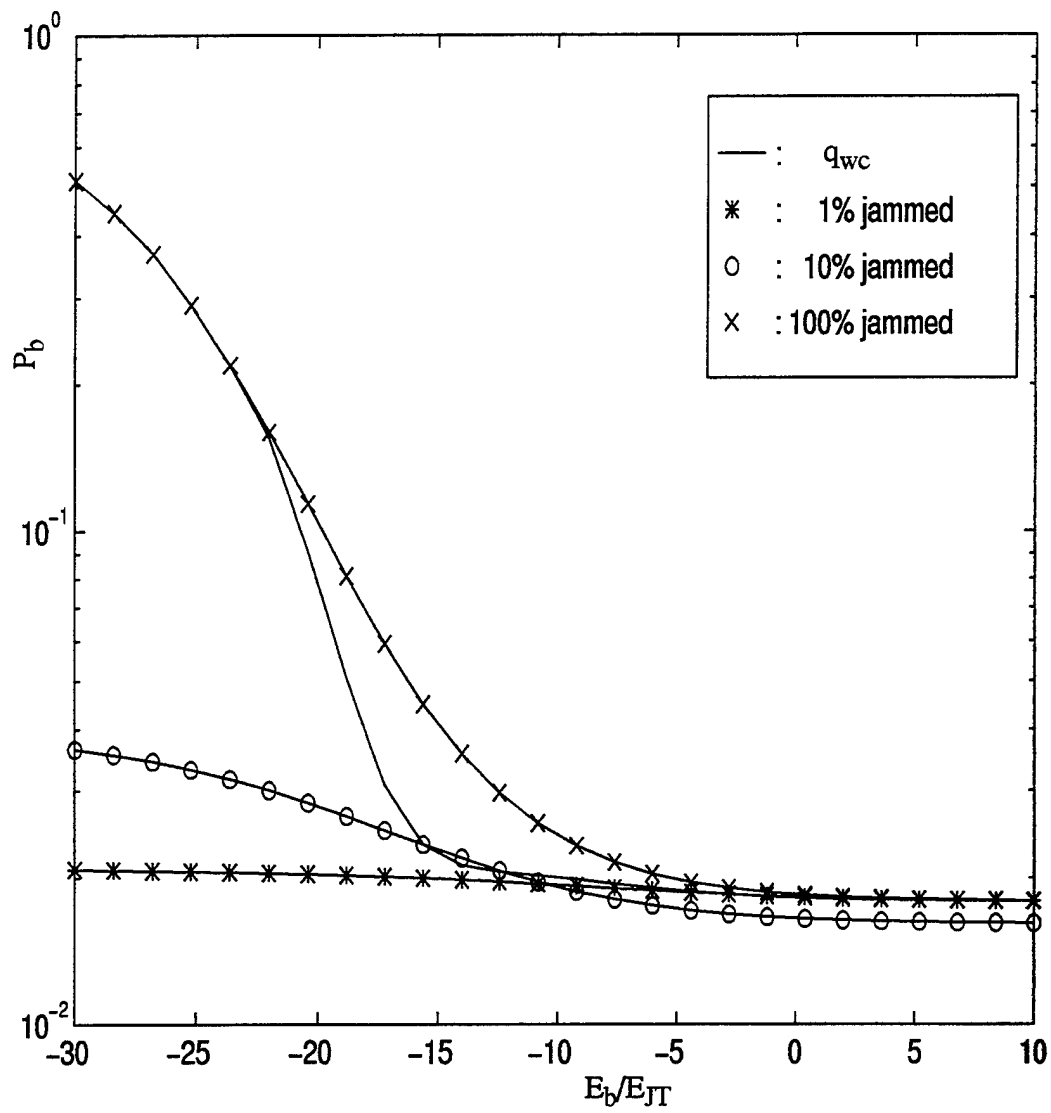

Figure 6: Probability of bit error for Rayleigh fading of both information signal and jamming tones, $L=6$, and $E_b/N_o = 13.35$ dB, for several jamming strategies.

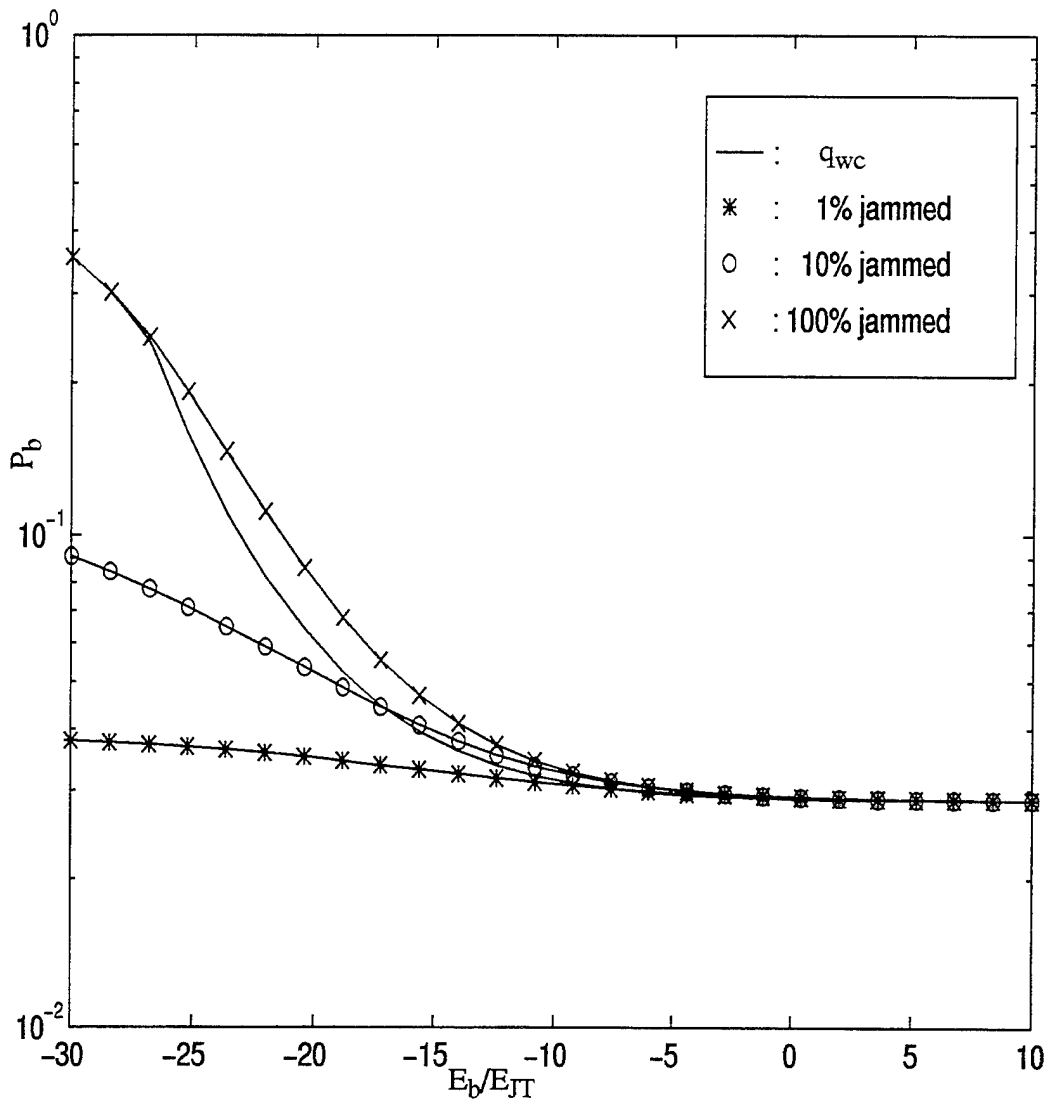

Figure 7: Probability of bit error for Rayleigh faded information signal and Ricean faded jamming tones ($\rho_j = 10$), $L=2$, and $E_b/N_o = 13.35$ dB, for several jamming strategies.

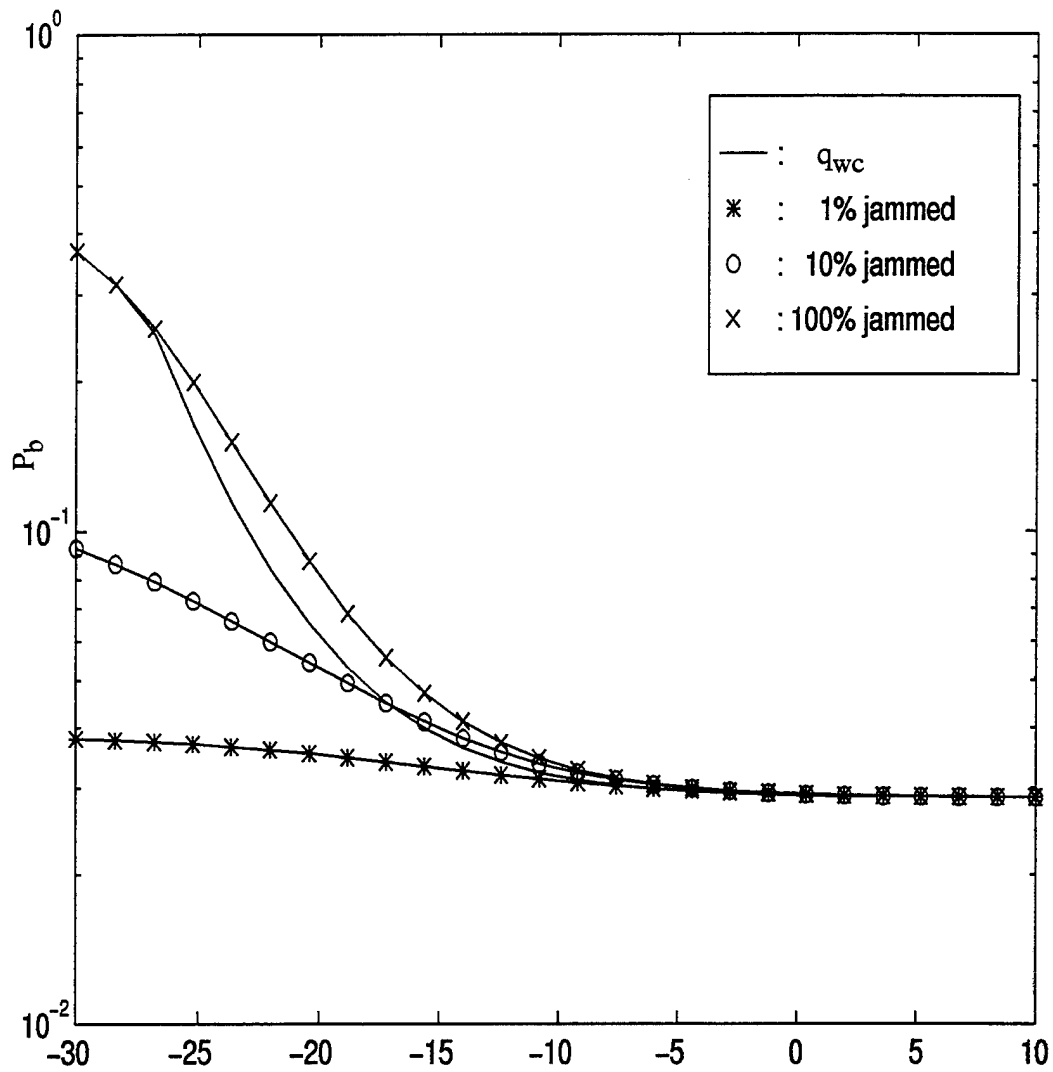

Figure 8: Probability of bit error for Rayleigh faded information signal and Ricean faded jamming tones ($\rho_j = 100$), $L=2$, and $E_b/N_0 = 13.35$ dB, for several jamming strategies.

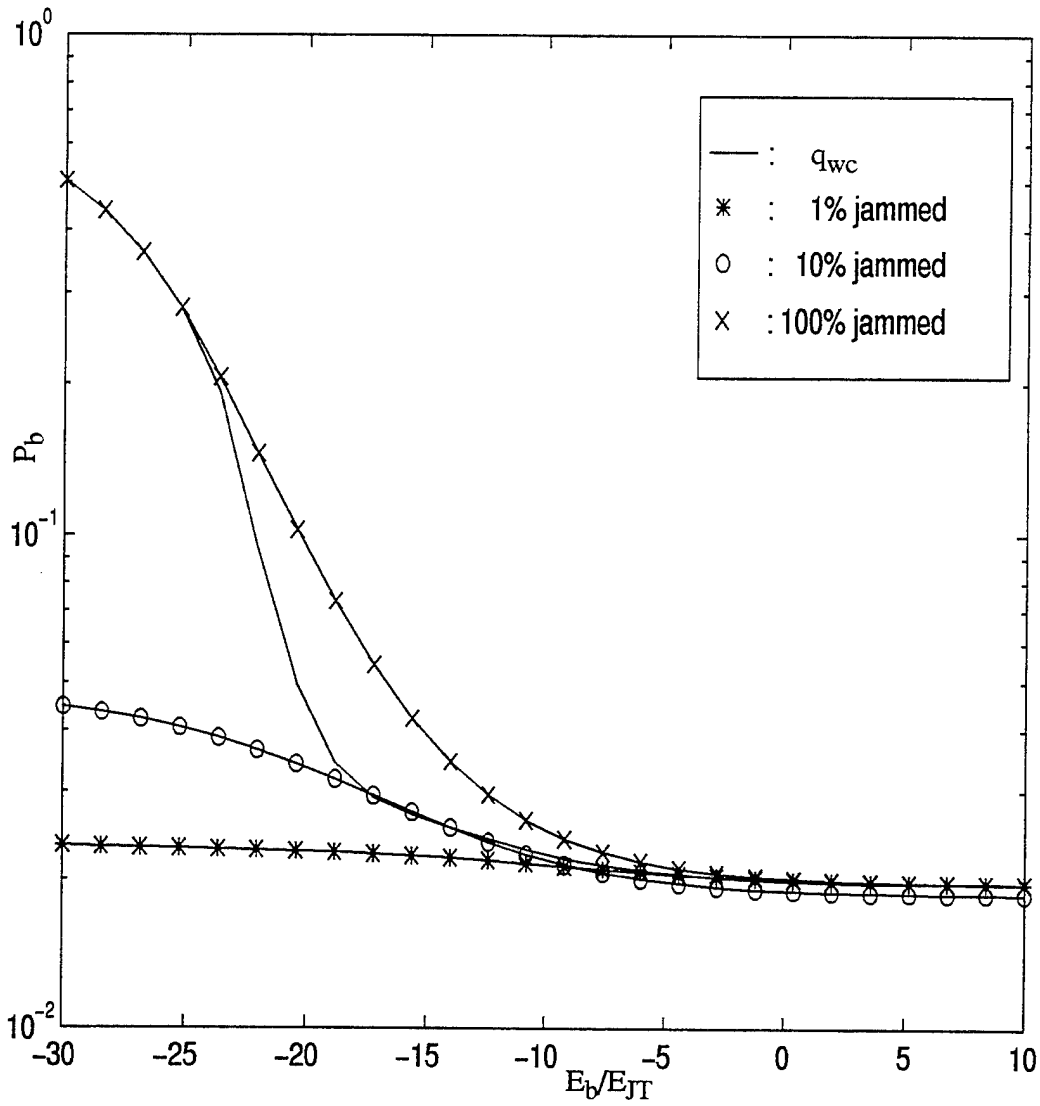

Figure 9: Probability of bit error for Rayleigh faded information signal and Ricean faded jamming tones ($\rho_j = 10$), $L=4$, and $E_b/N_o = 13.35$ dB, for several jamming strategies.

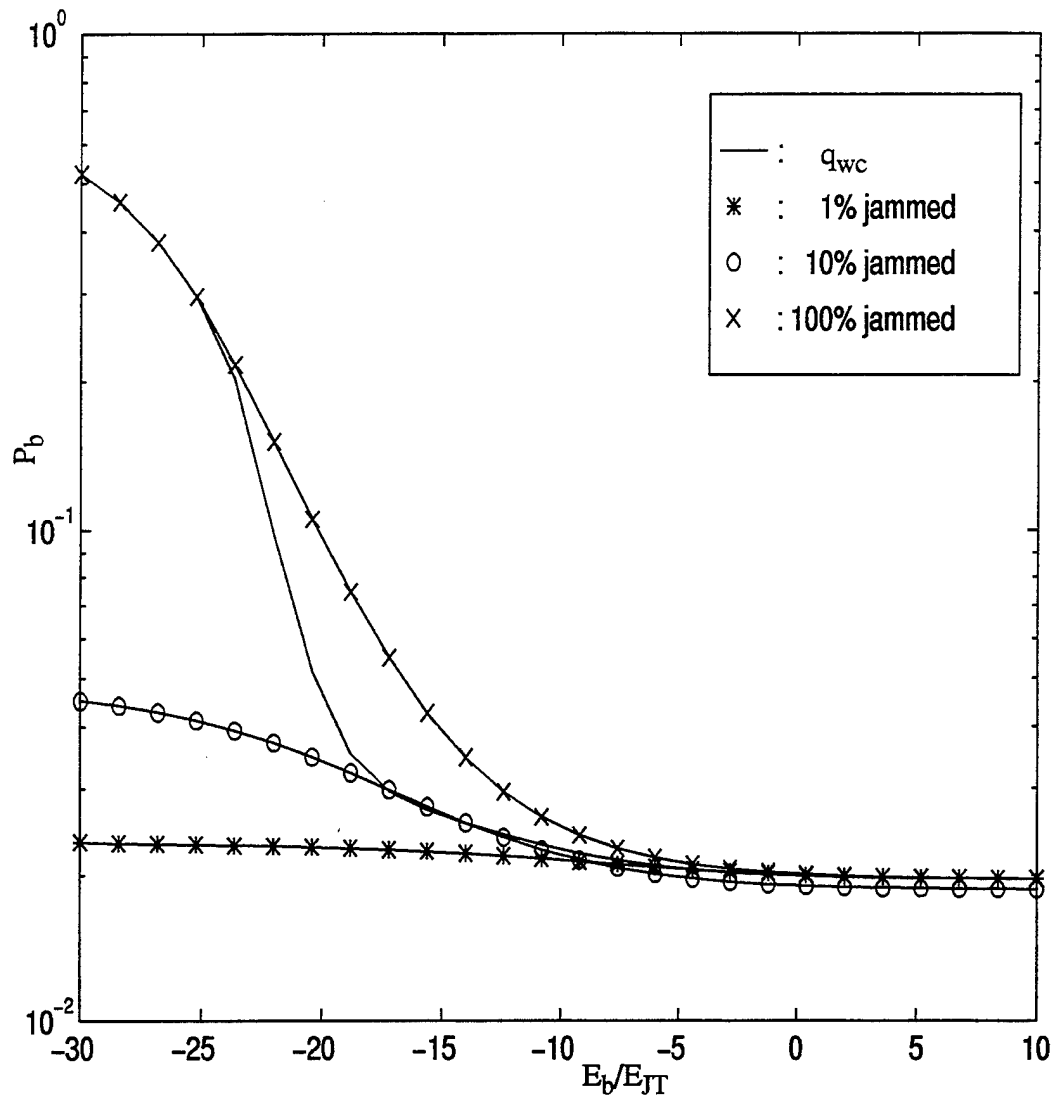

Figure 10: Probability of bit error for Rayleigh faded information signal and Ricean faded jamming tones ($\rho_j = 100$), $L=4$, and $E_b/N_o = 13.35$ dB, for several jamming strategies.

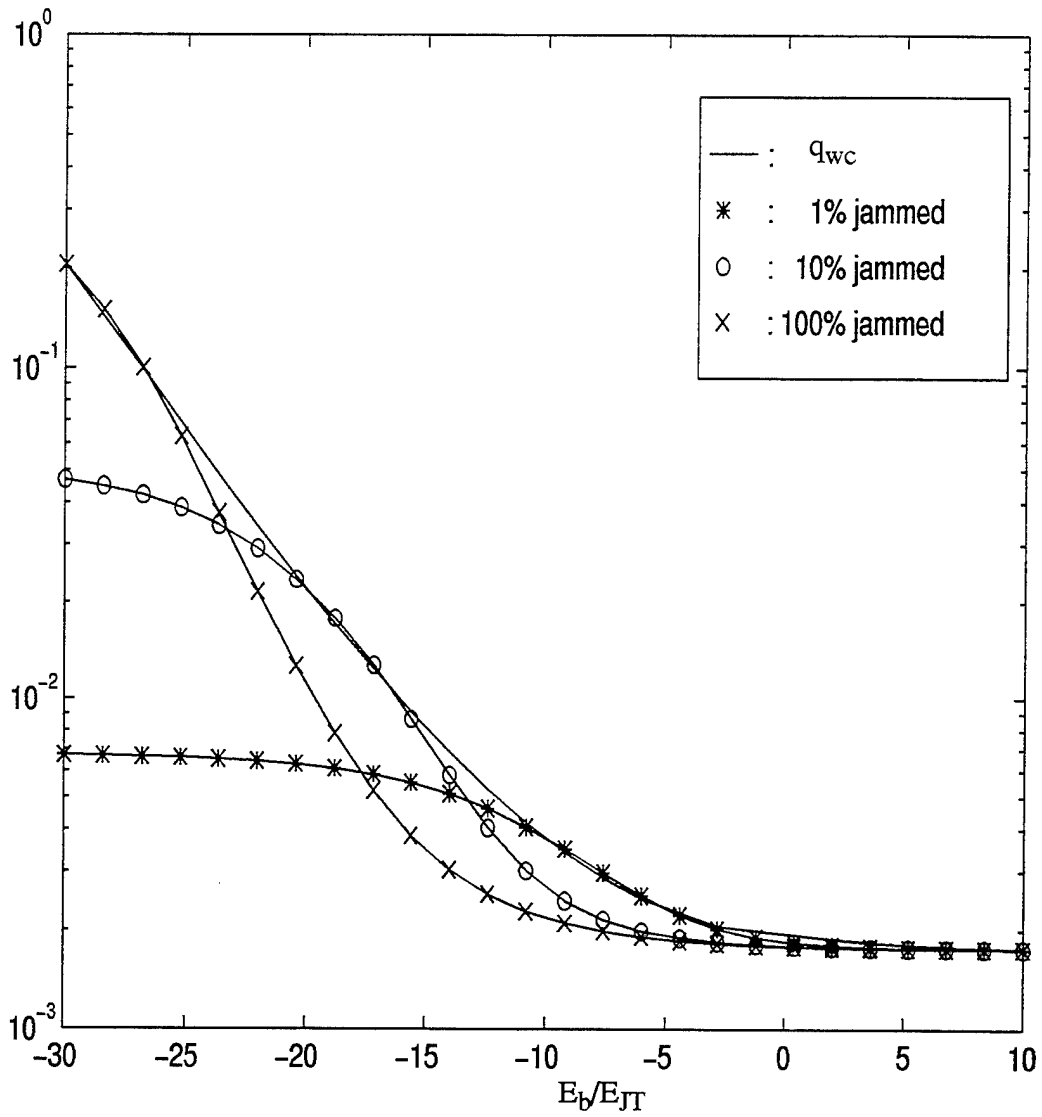

Figure 11: Probability of bit error for Ricean faded information signal ($\rho_c = 10$), and Rayleigh faded jamming tone, $L=1$, and $E_b/N_0 = 13.35$ dB for several jamming strategies.

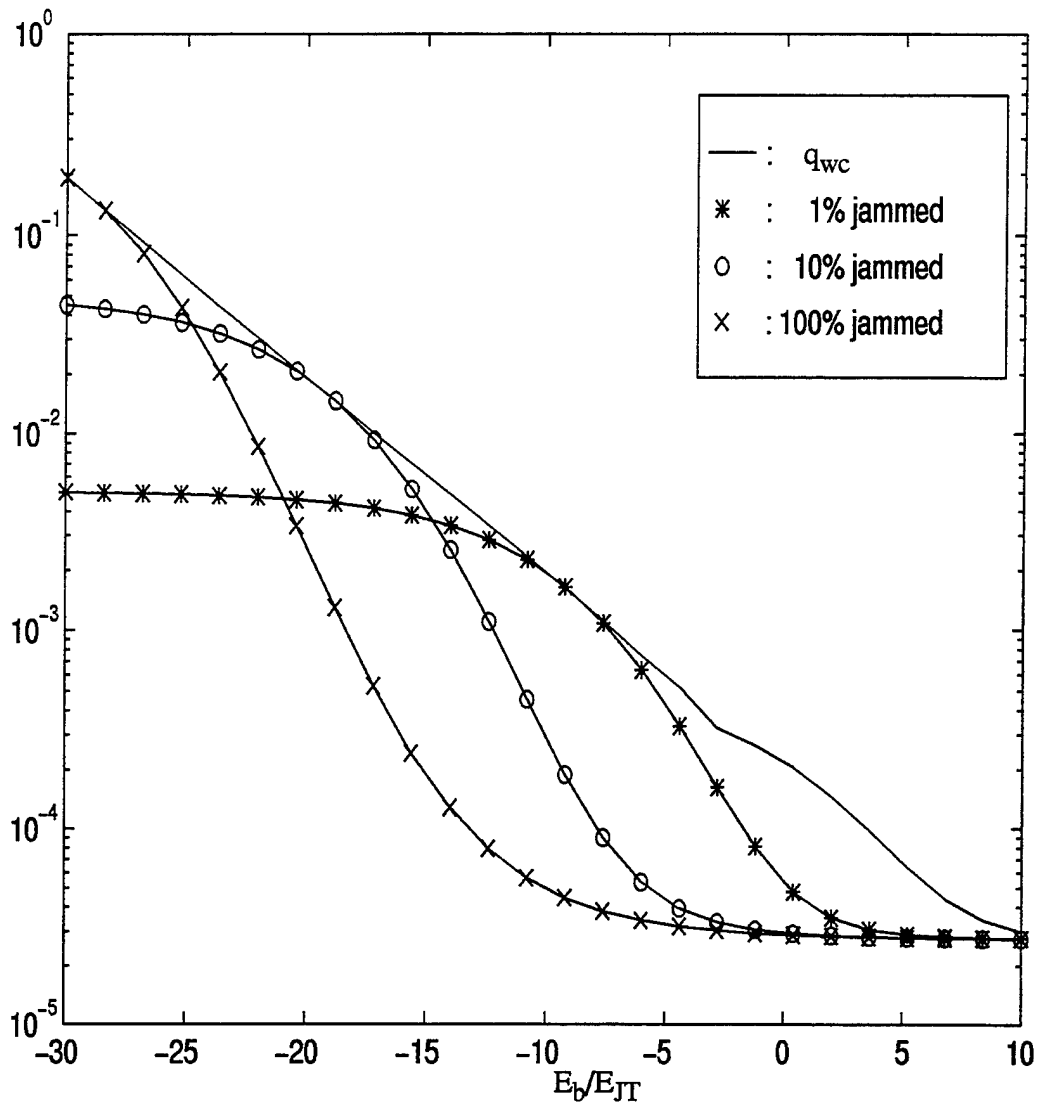

Figure 12: Probability of bit error for Ricean faded information signal ($\rho_c = 100$) and Rayleigh faded jamming tone, $L=1$, and $E_b/N_0 = 13.35$ dB for several jamming strategies.

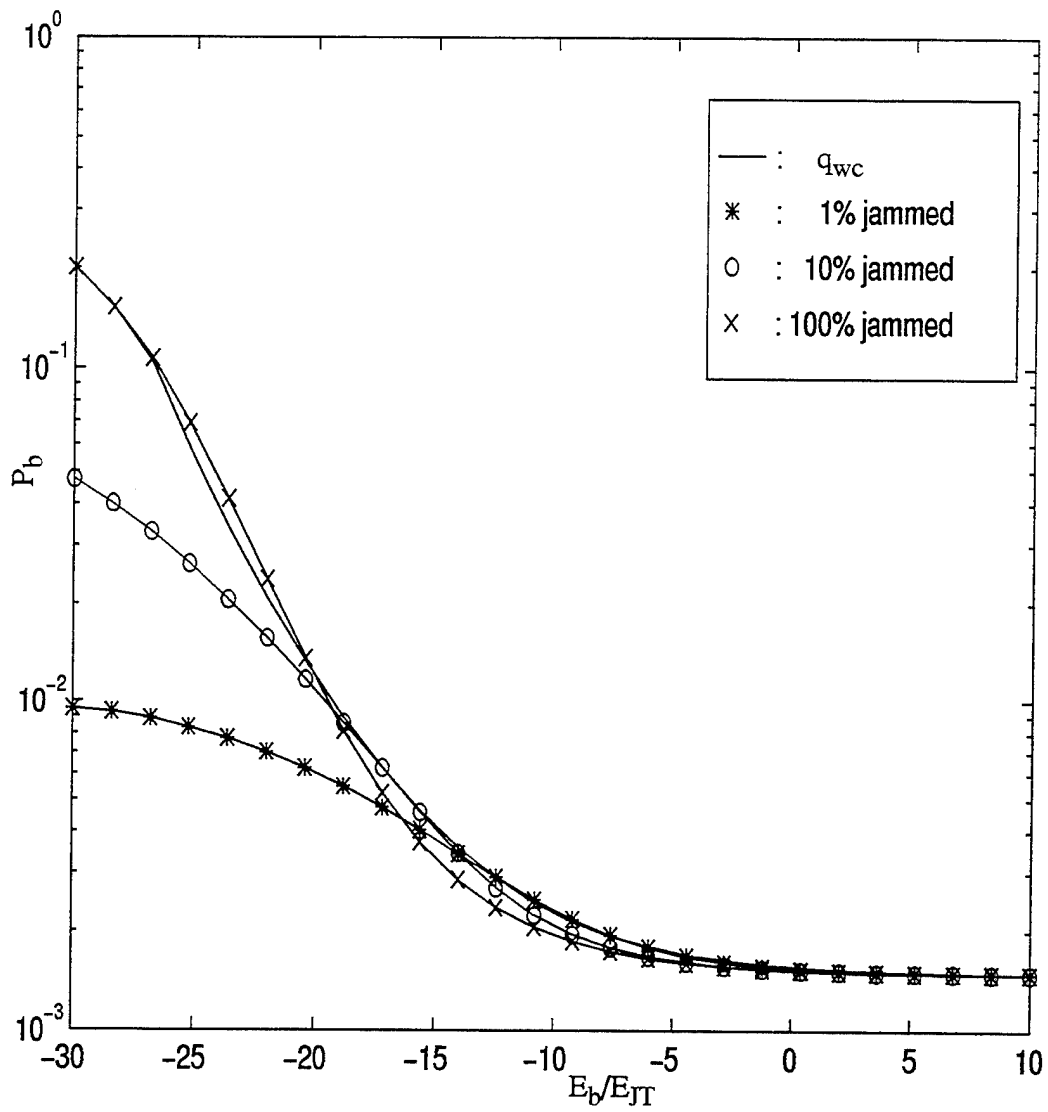

Figure 13: Probability of bit error for Ricean faded information signal ($\rho_c = 10$) and Rayleigh faded jamming tone, $L = 2$, and $E_b/N_0 = 13.35$ dB for several jamming strategies.

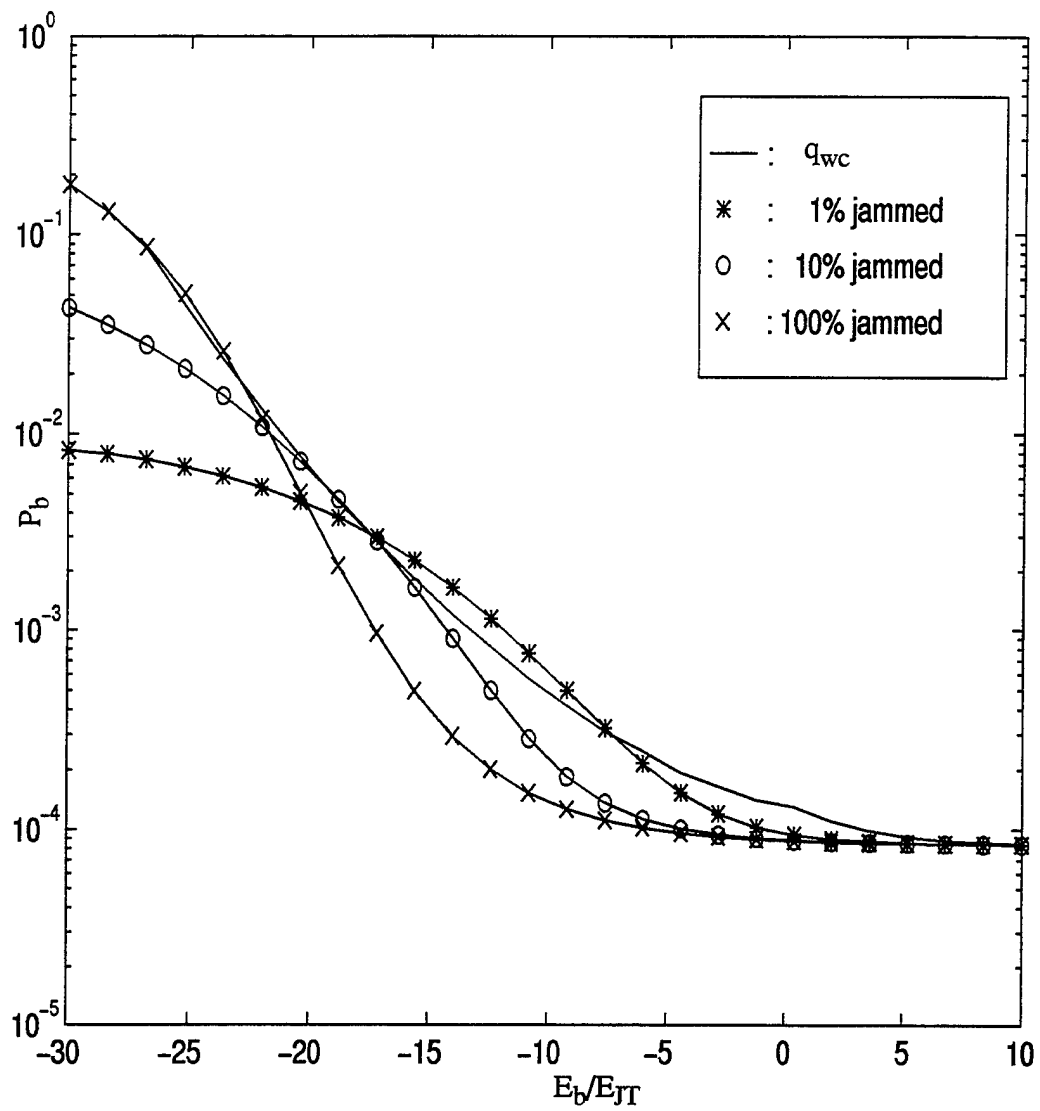

Figure 14: Probability of bit error for Ricean faded information signal ($\rho_c = 100$) and Rayleigh faded jamming tone, $L = 2$, and $E_b/N_o = 13.35$ dB for several jamming strategies.

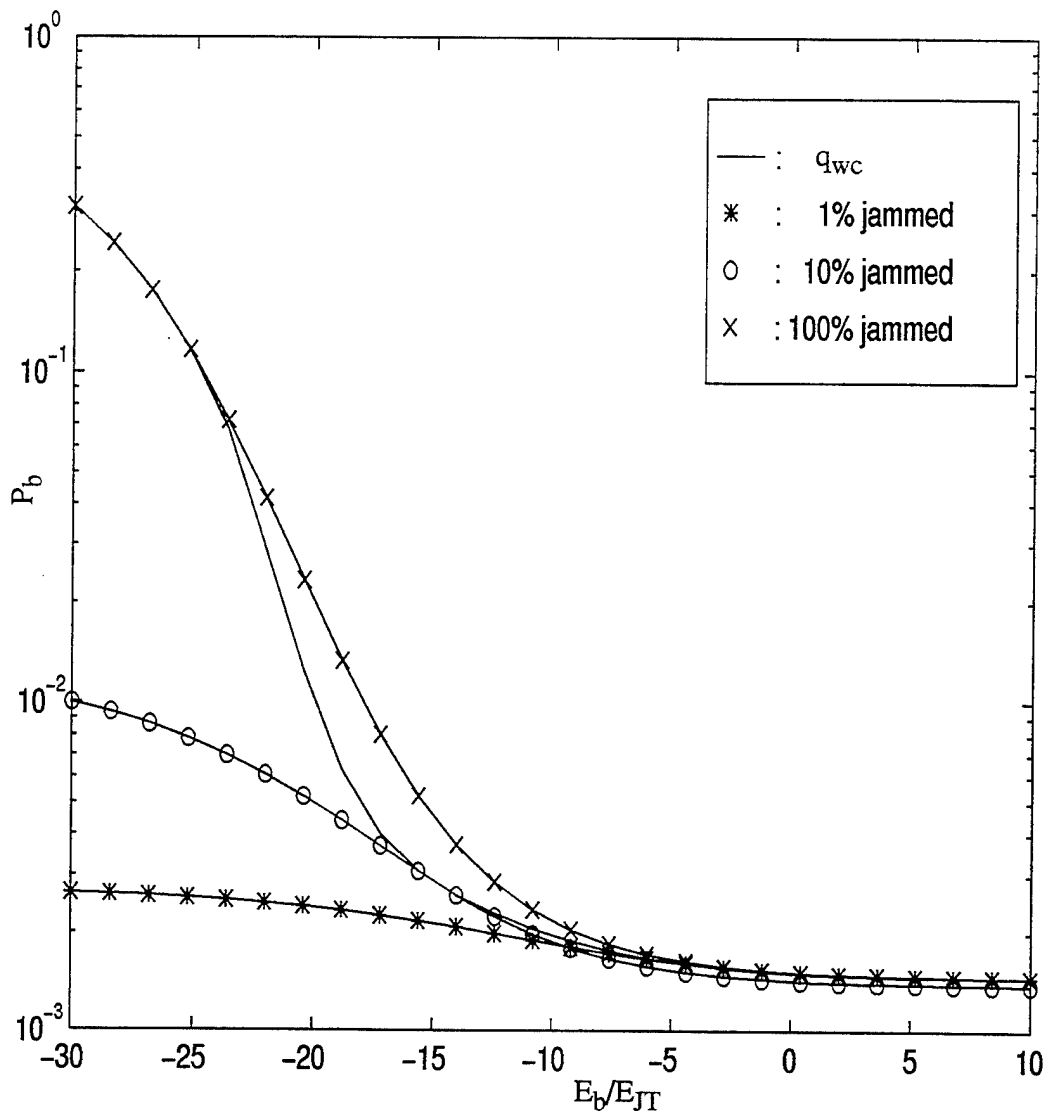

Figure 15: Probability of bit error for Ricean faded information signal ($\rho_c = 10$) and Rayleigh faded jamming tone, $L = 4$, and $E_b/N_o = 13.35$ dB for several jamming strategies.

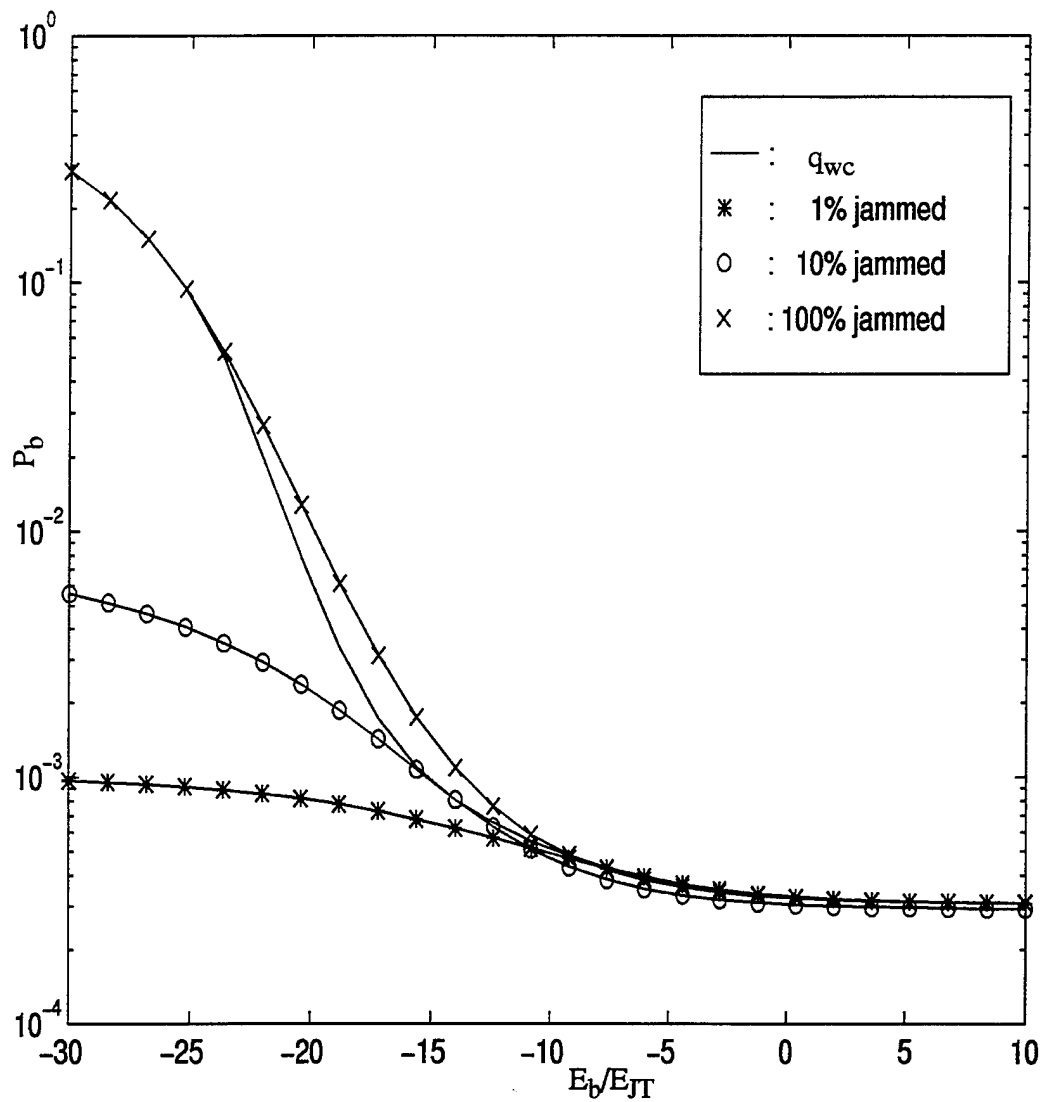

Figure 16: Probability of bit error for Ricean faded information signal ($\rho_c = 100$) and Rayleigh faded jamming tone, $L = 4$, and $E_b/N_0 = 13.35$ dB for several jamming strategies.

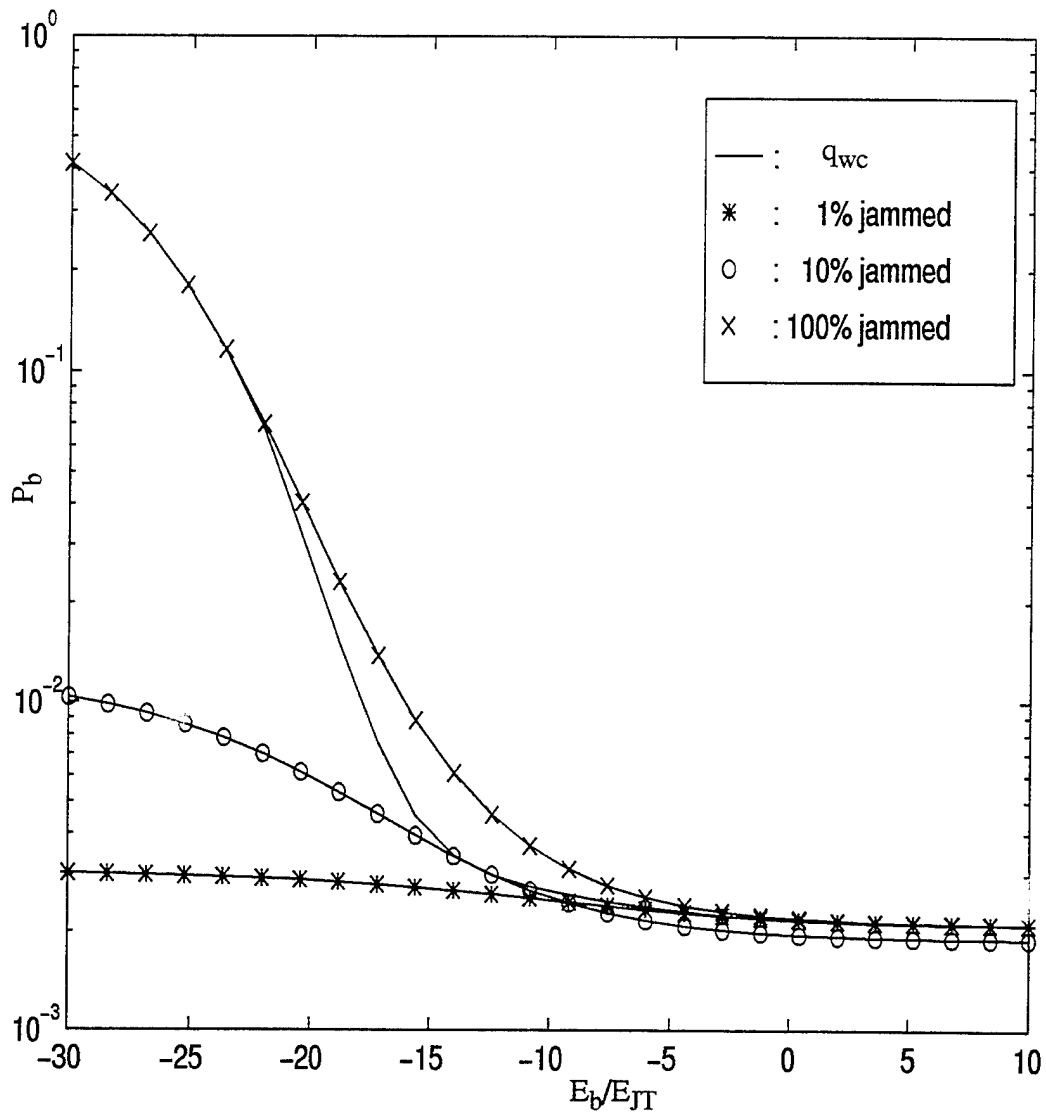

Figure 17: Probability of bit error for Ricean faded information signal ($\rho_c = 10$) and Rayleigh faded jamming tone, $L = 6$, and $E_b/N_o = 13.35$ dB for several jamming strategies.

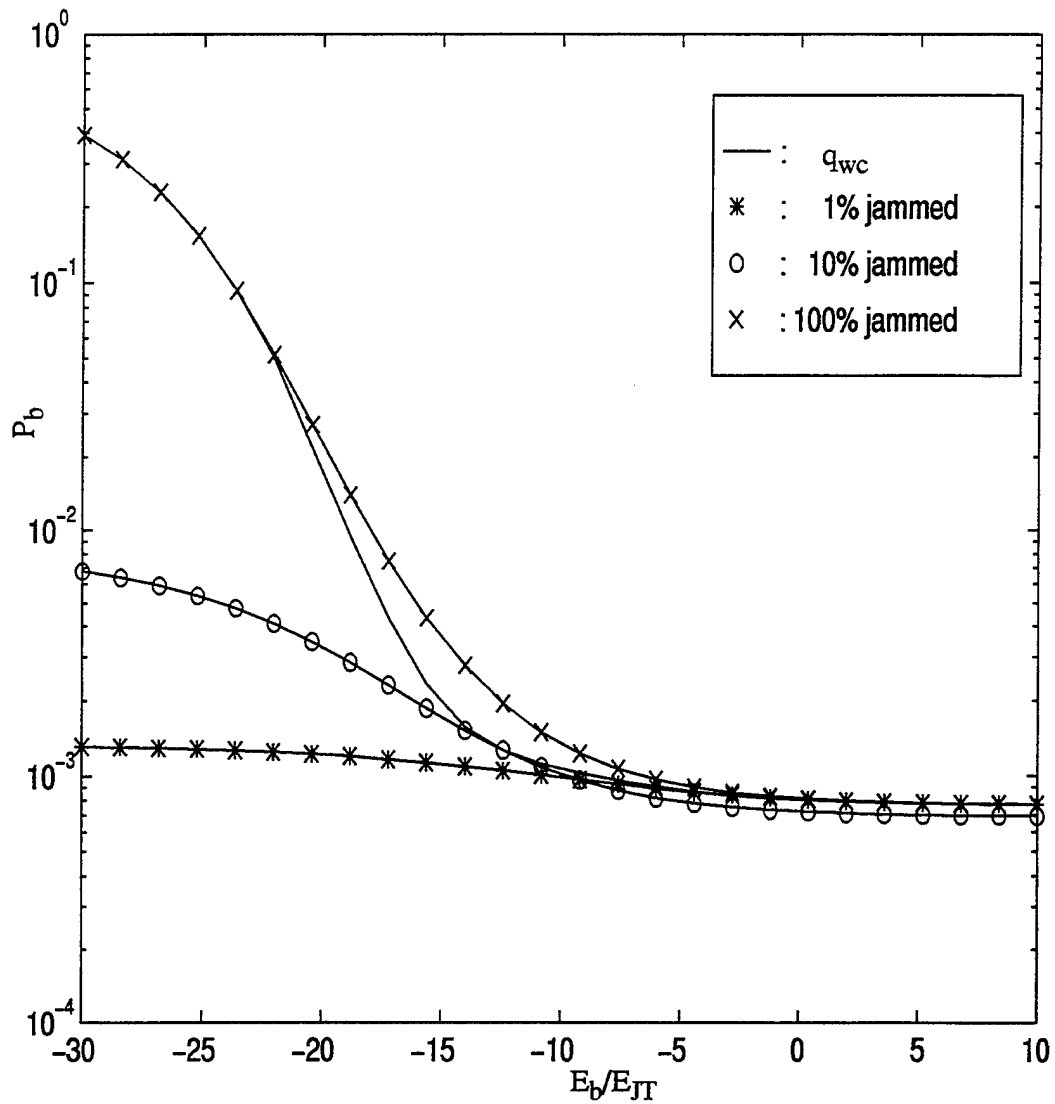

Figure 18: Probability of bit error for Ricean faded information signal ($\rho_c = 100$) and Rayleigh faded jamming tone, $L = 6$, and $E_b/N_0 = 13.35$ dB for several jamming strategies.

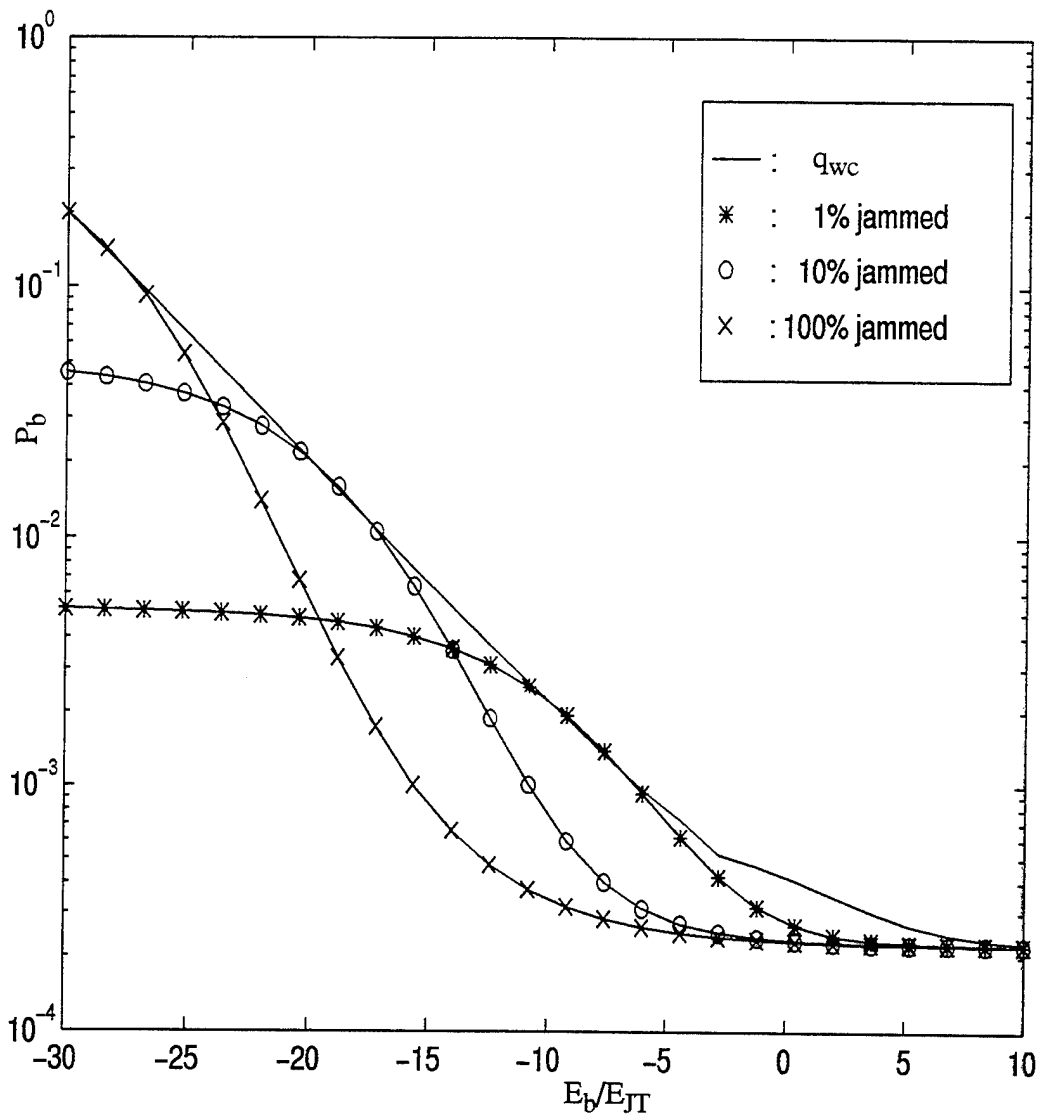

Figure 19: Probability of bit error for Ricean faded information signal ($\rho_c = 10$) and Rayleigh faded jamming tone, $L = 1$, and $E_b/N_0 = 16.35$ dB for several jamming strategies.

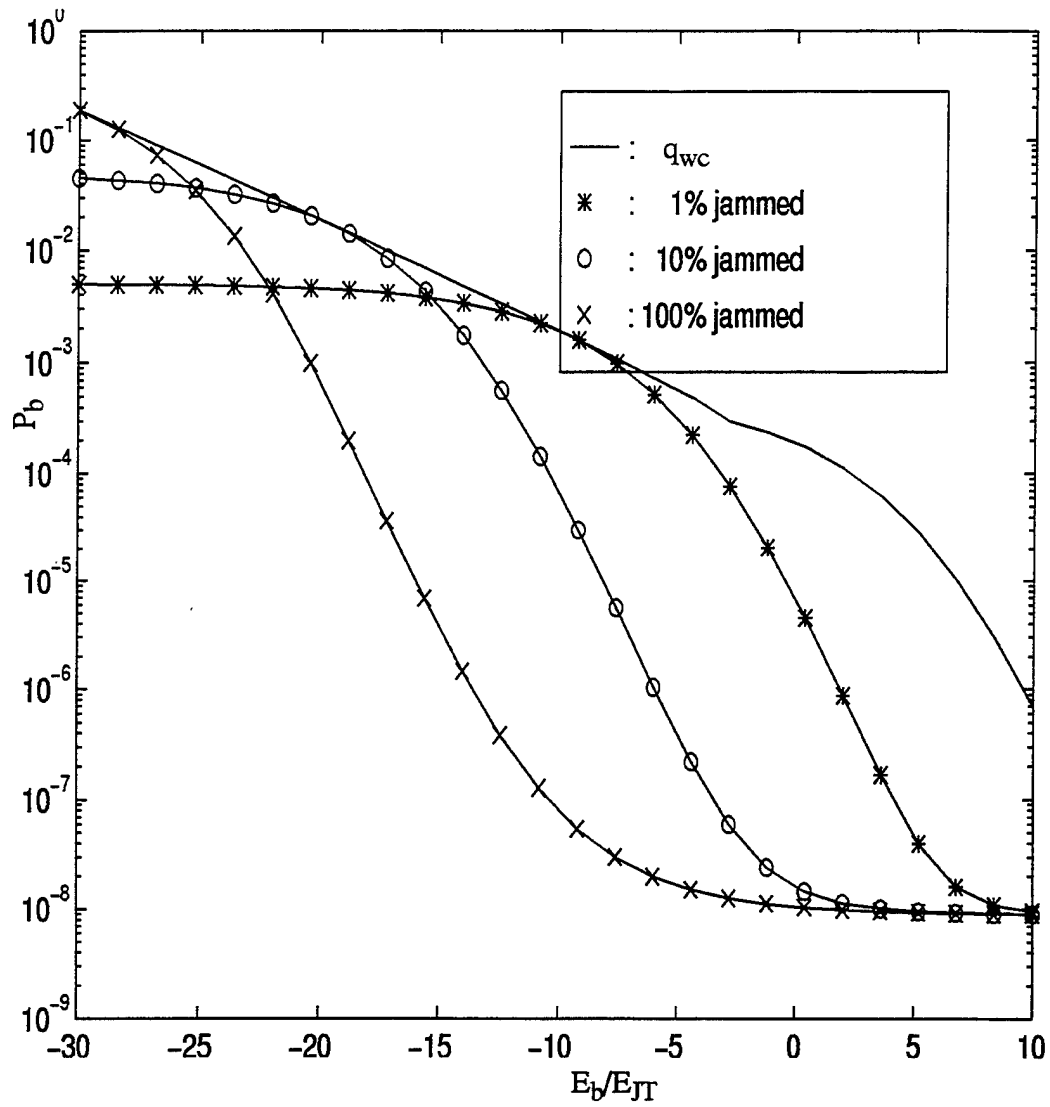

Figure 20: Probability of bit error for Ricean faded information signal ($\rho_c = 100$) and Rayleigh faded jamming tone, $L = 1$, and $E_b/N_o = 16.35$ dB for several jamming strategies.

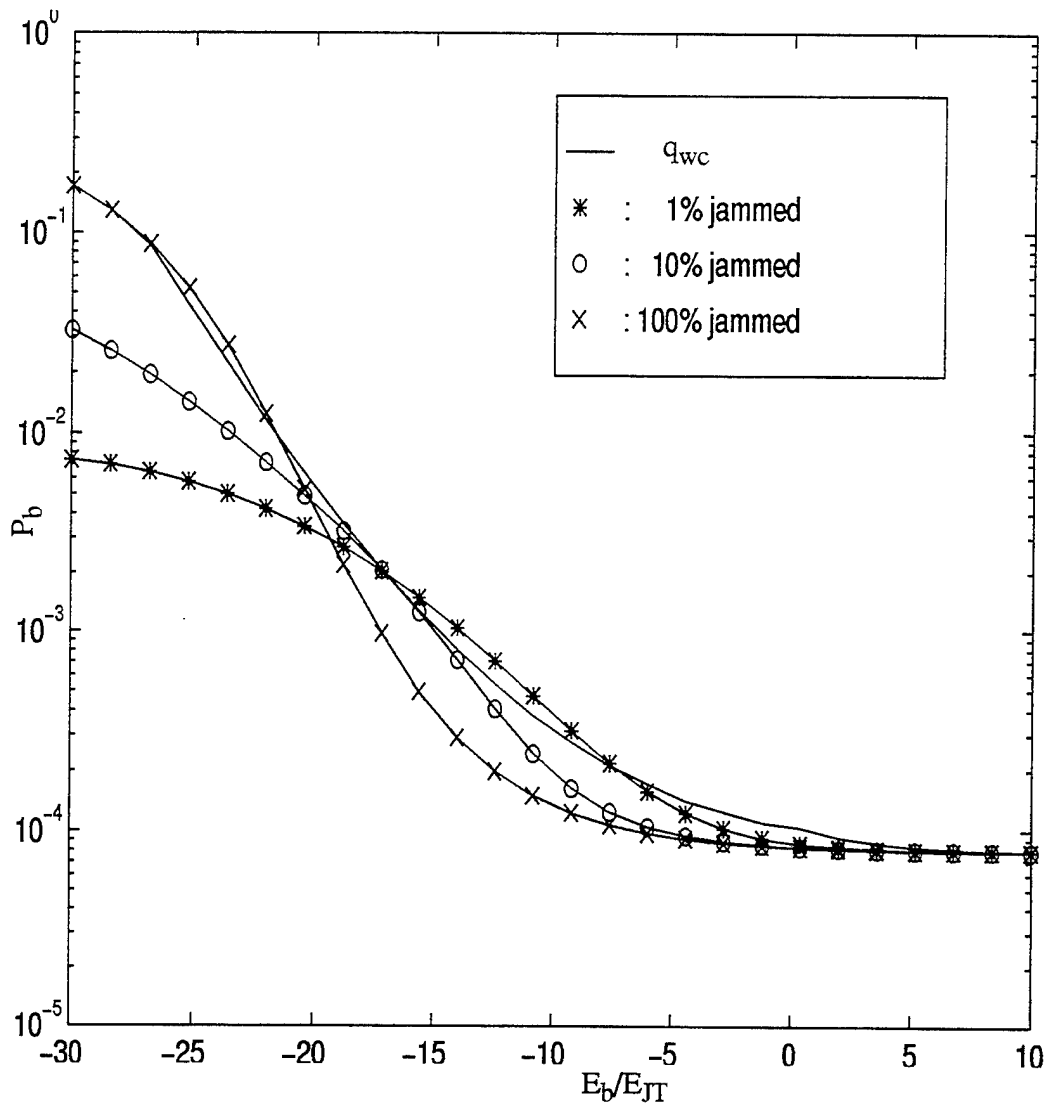

Figure 21: Probability of bit error for Ricean faded information signal ($\rho_c = 10$) and Rayleigh faded jamming tone, $L = 2$, and $E_b/N_0 = 16.35$ dB for several jamming strategies.

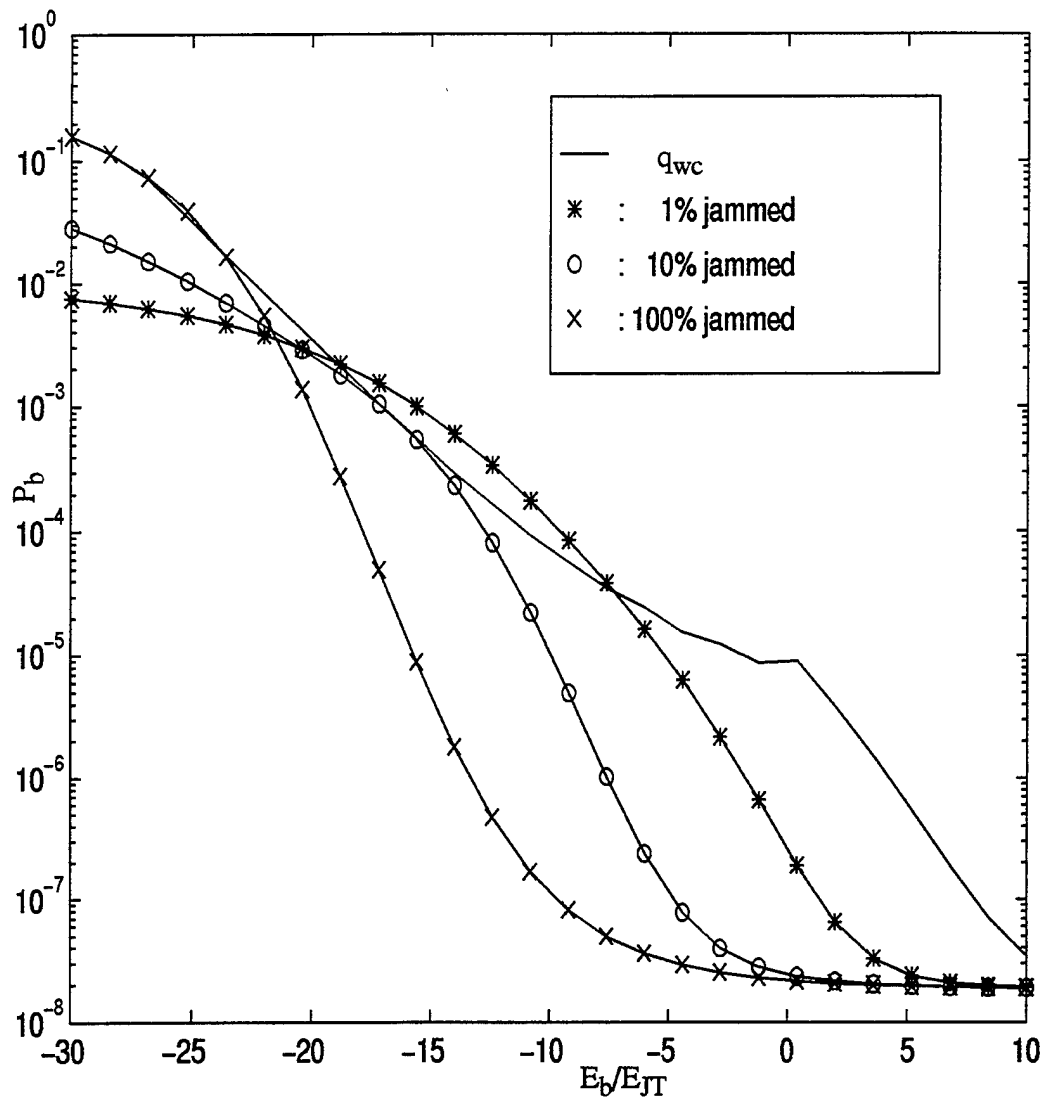

Figure 22: Probability of bit error for Ricean faded information signal ($\rho_c = 100$) and Rayleigh faded jamming tone, $L = 2$, and $E_b/N_0 = 16.35$ dB for several jamming strategies.

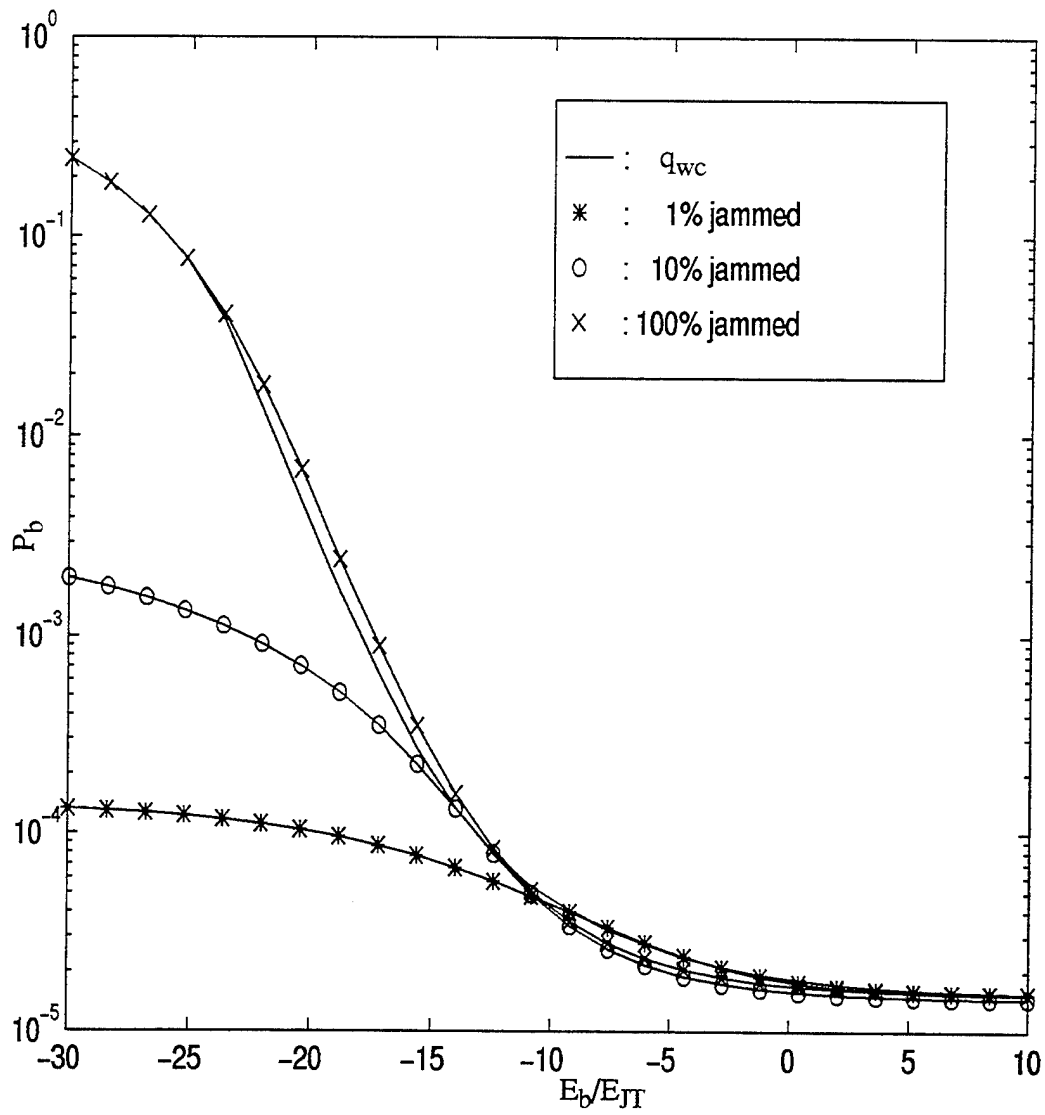

Figure 23: Probability of bit error for Ricean faded information signal ($\rho_c = 10$) and Rayleigh faded jamming tone, $L = 4$, and $E_b/N_0 = 16.35$ dB for several jamming strategies.

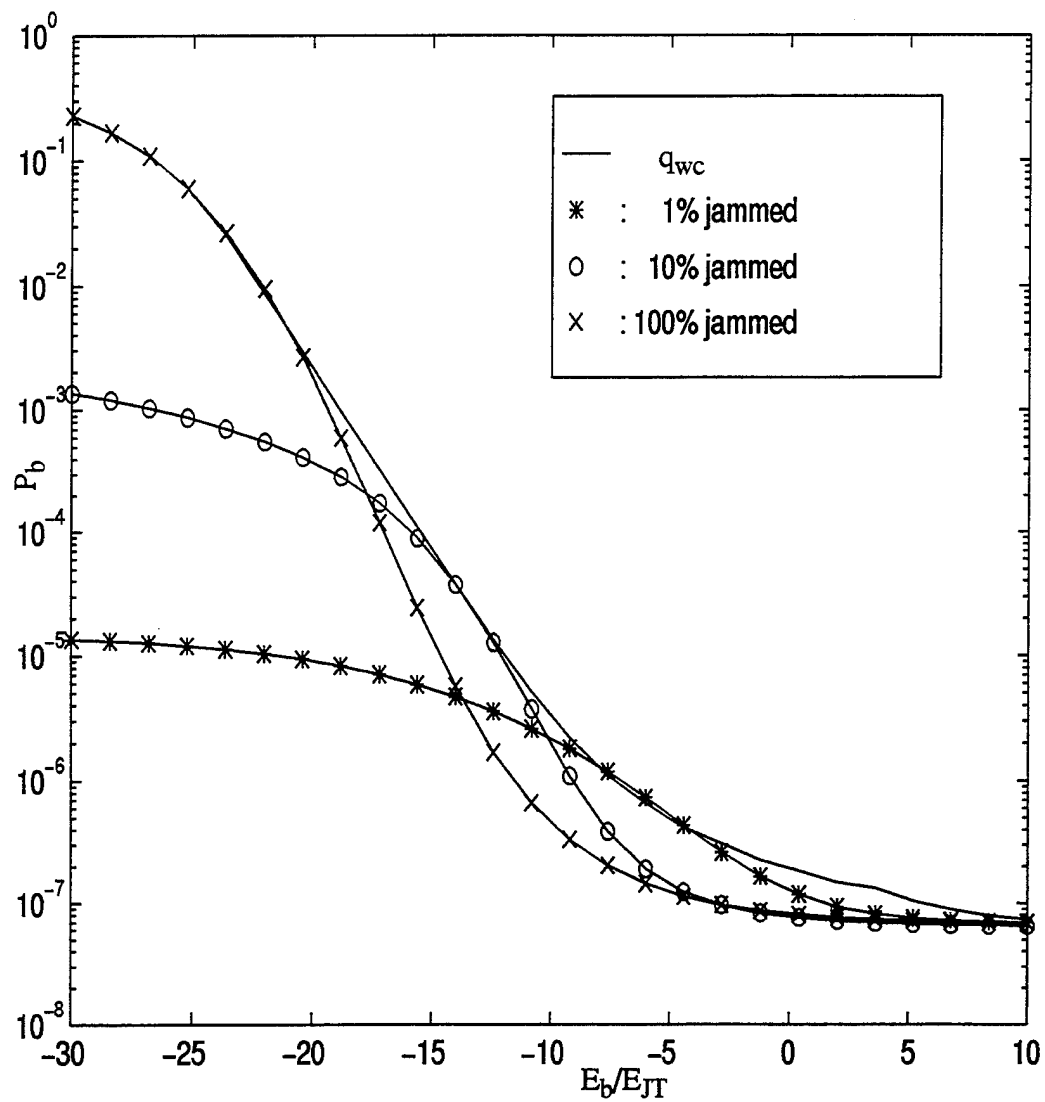

Figure 24: Probability of bit error for Ricean faded information signal ($\rho_c = 100$) and Rayleigh faded jamming tone, $L = 4$, and $E_b/N_o = 16.35$ dB for several jamming strategies.

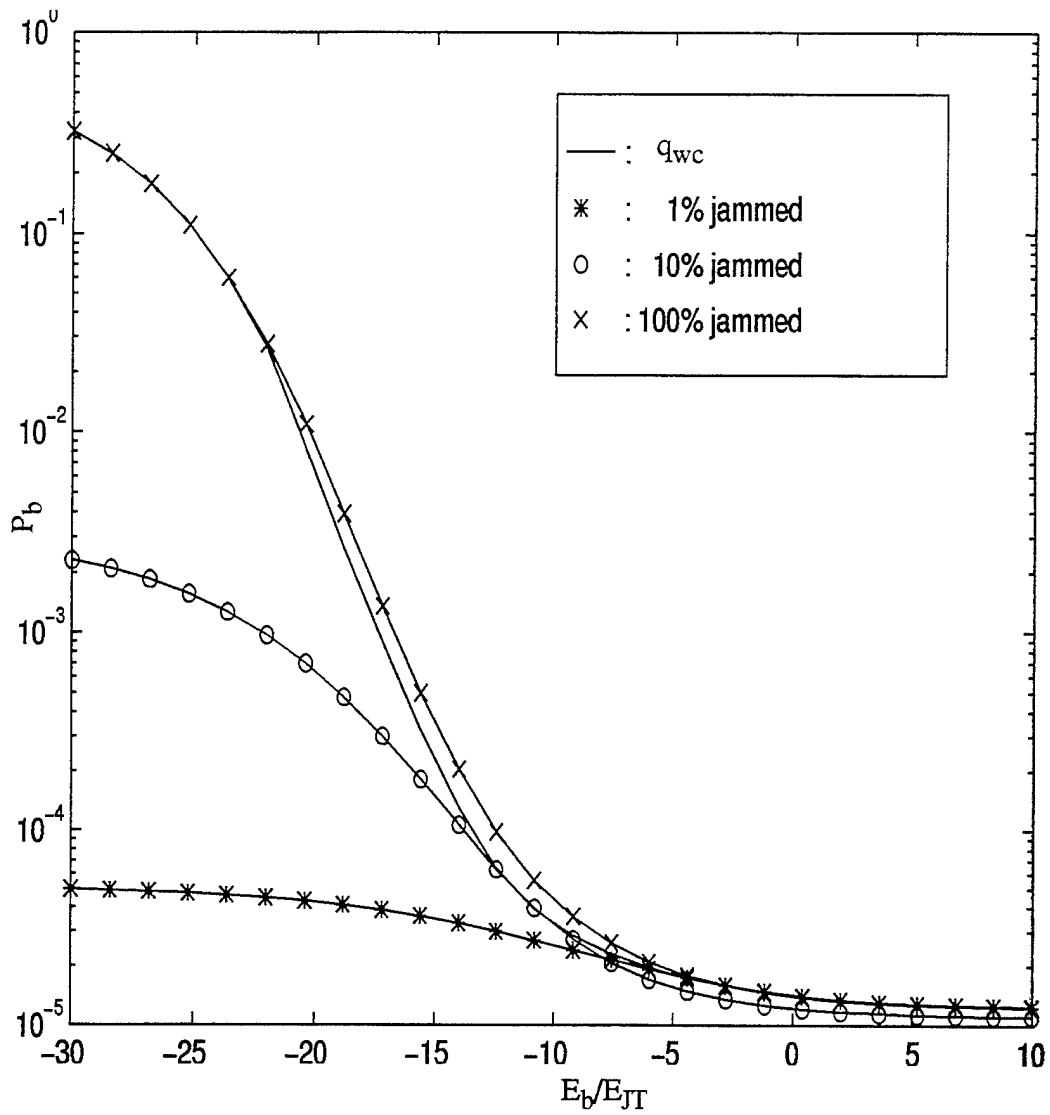

Figure 25: Probability of bit error for Ricean faded information signal ($\rho_c = 10$) and Rayleigh faded jamming tone, $L = 6$, and $E_b/N_0 = 16.35$ dB for several jamming strategies.

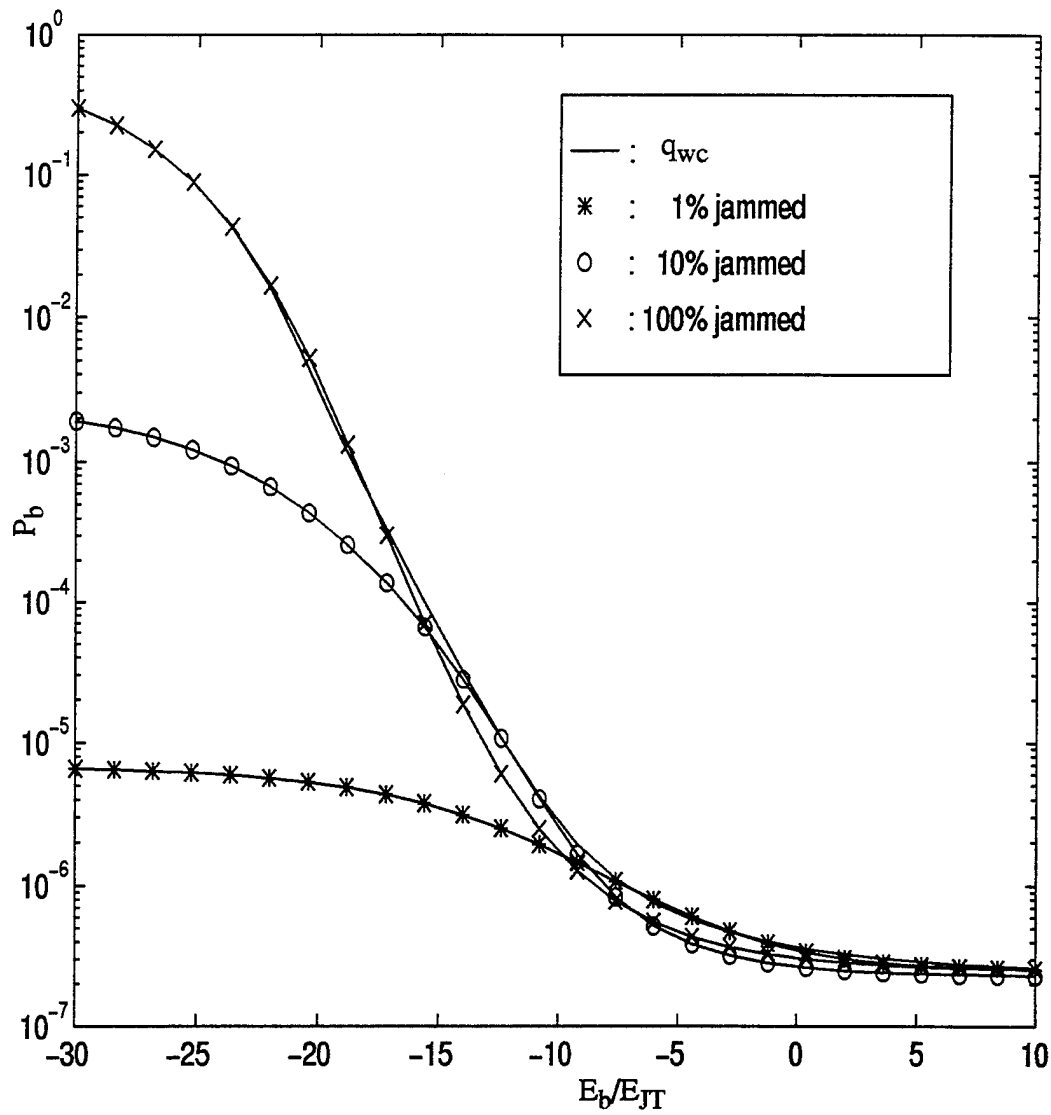

Figure 26: Probability of bit error for Ricean faded information signal ($\rho_c = 100$) and Rayleigh faded jamming tone, $L = 6$, and $E_b/N_o = 16.35$ dB for several jamming strategies.

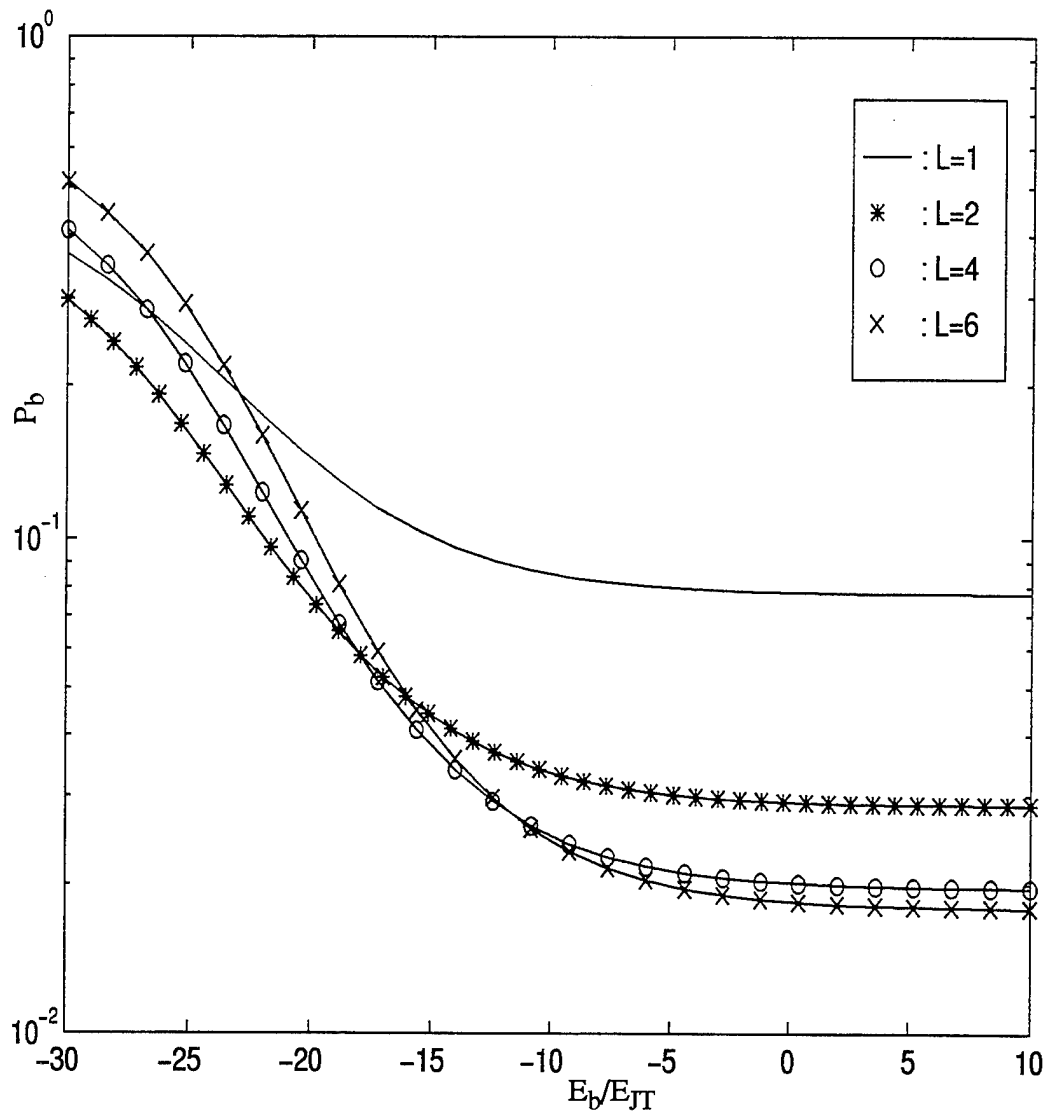

Figure 27: Probability of bit error for Rayleigh-faded signal and jamming tone ($\rho_e, \rho_J = 0$) ($E_b/N_o = 13.35\text{dB}$), for diversity $L = 1, 2, 4, 6$ and actual worst case jamming.

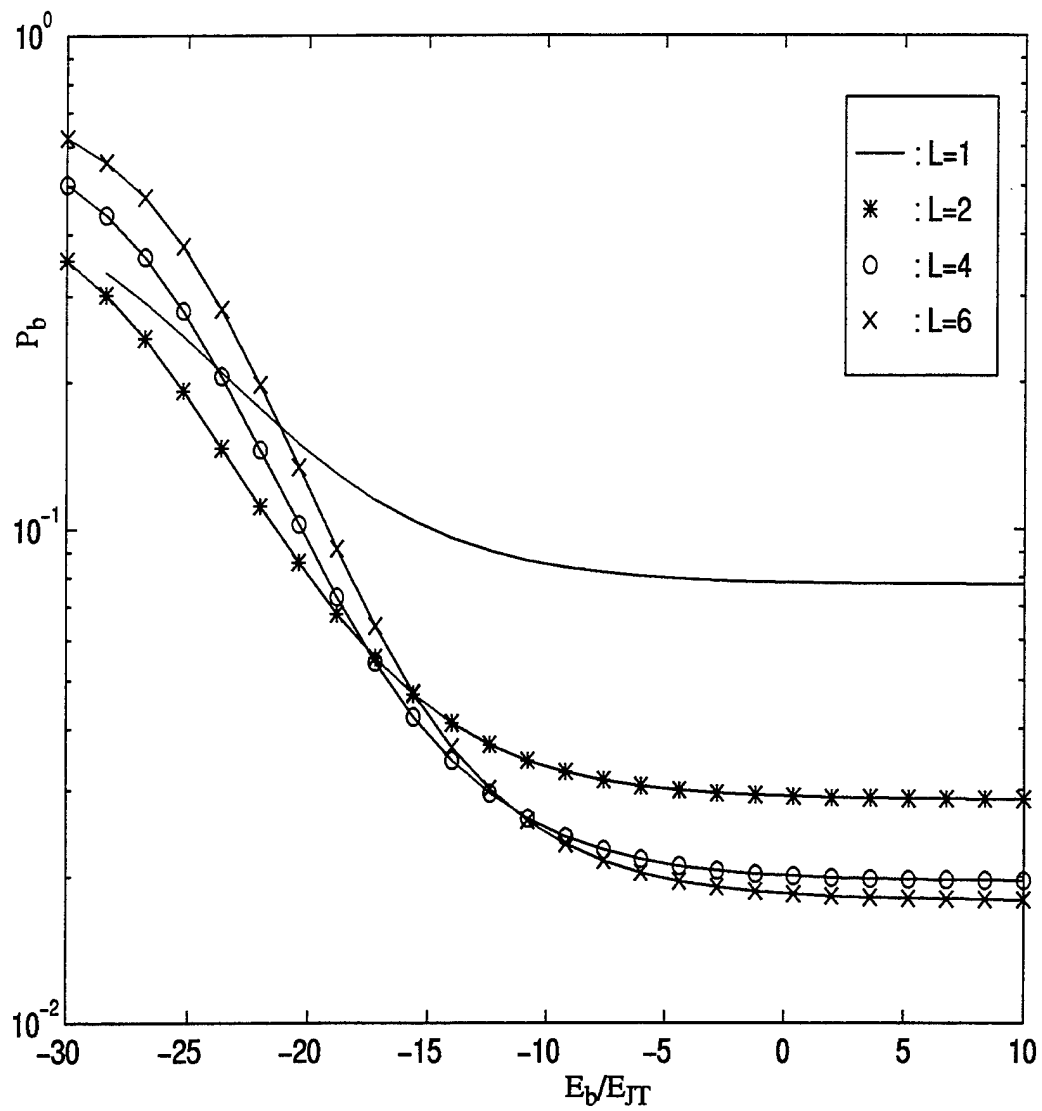

Figure 28: Probability of bit error for Rayleigh-faded signal ($E_b/N_o = 13.35\text{dB}$) and Ricean faded jamming tone ($\rho_j = 10$), for diversity $L = 1, 2, 4, 6$ and actual worst case jamming.

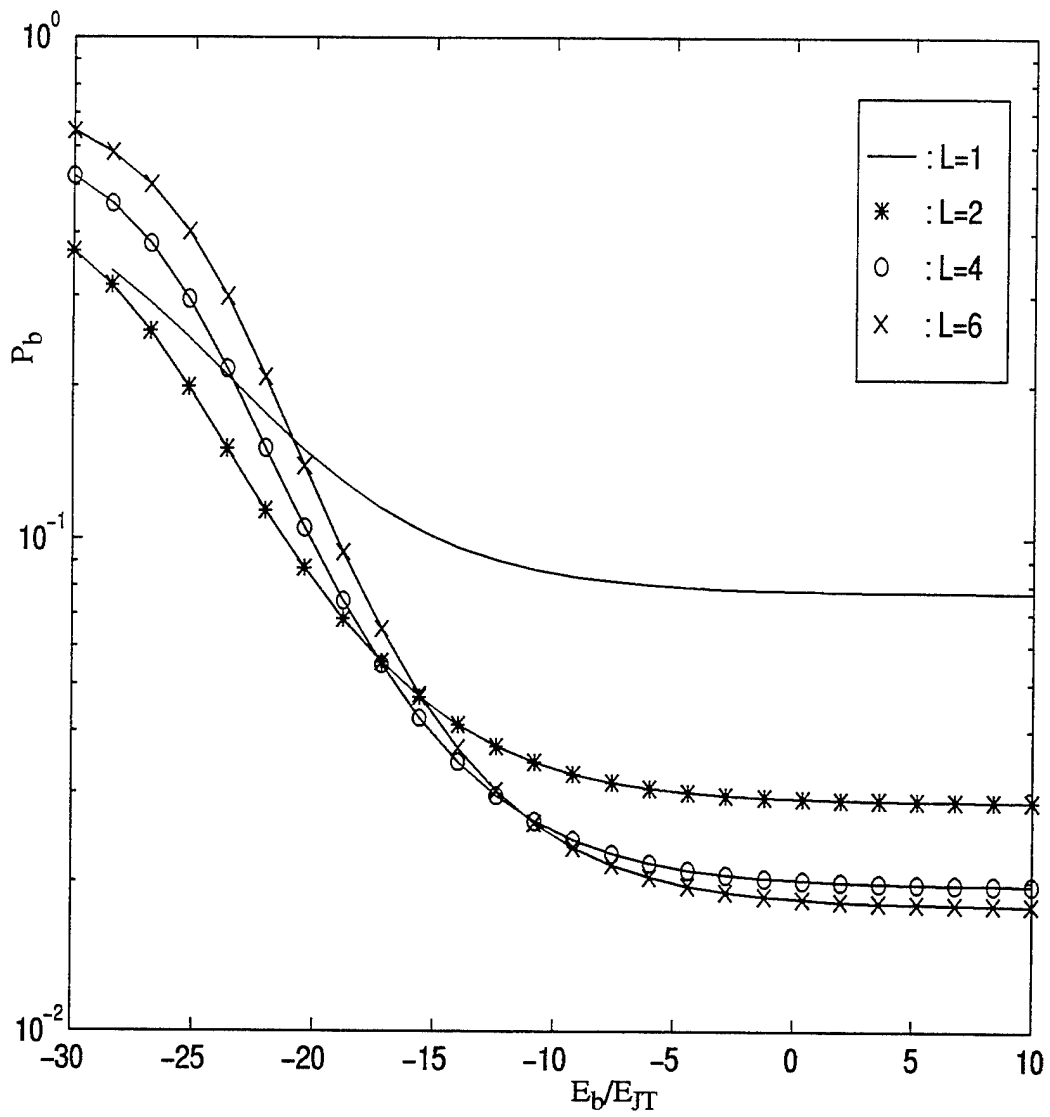

Figure 29: Probability of bit error for Rayleigh-faded signal ($E_b/N_o = 13.35\text{dB}$) and Ricean faded jamming tone ($\rho_j = 100$), for diversity $L = 1, 2, 4, 6$ and actual worst case jamming.

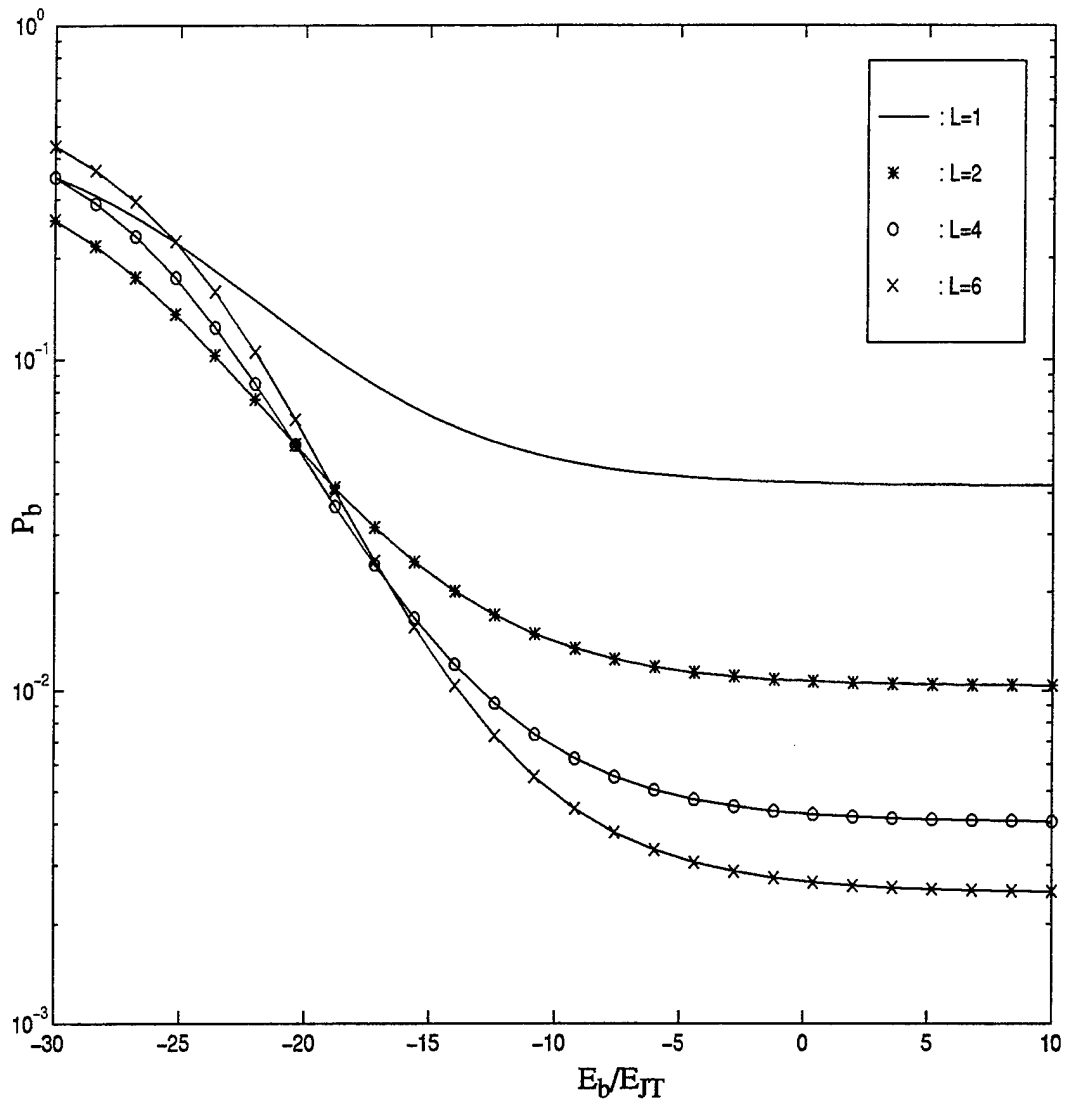

Figure 30: Probability of bit error for Rayleigh-faded signal ($E_b/N_0 = 16.65\text{dB}$) and jamming tone ($\rho_c, \rho_j = 0$, for diversity $L = 1, 2, 4, 6$ and actual worst case jamming).

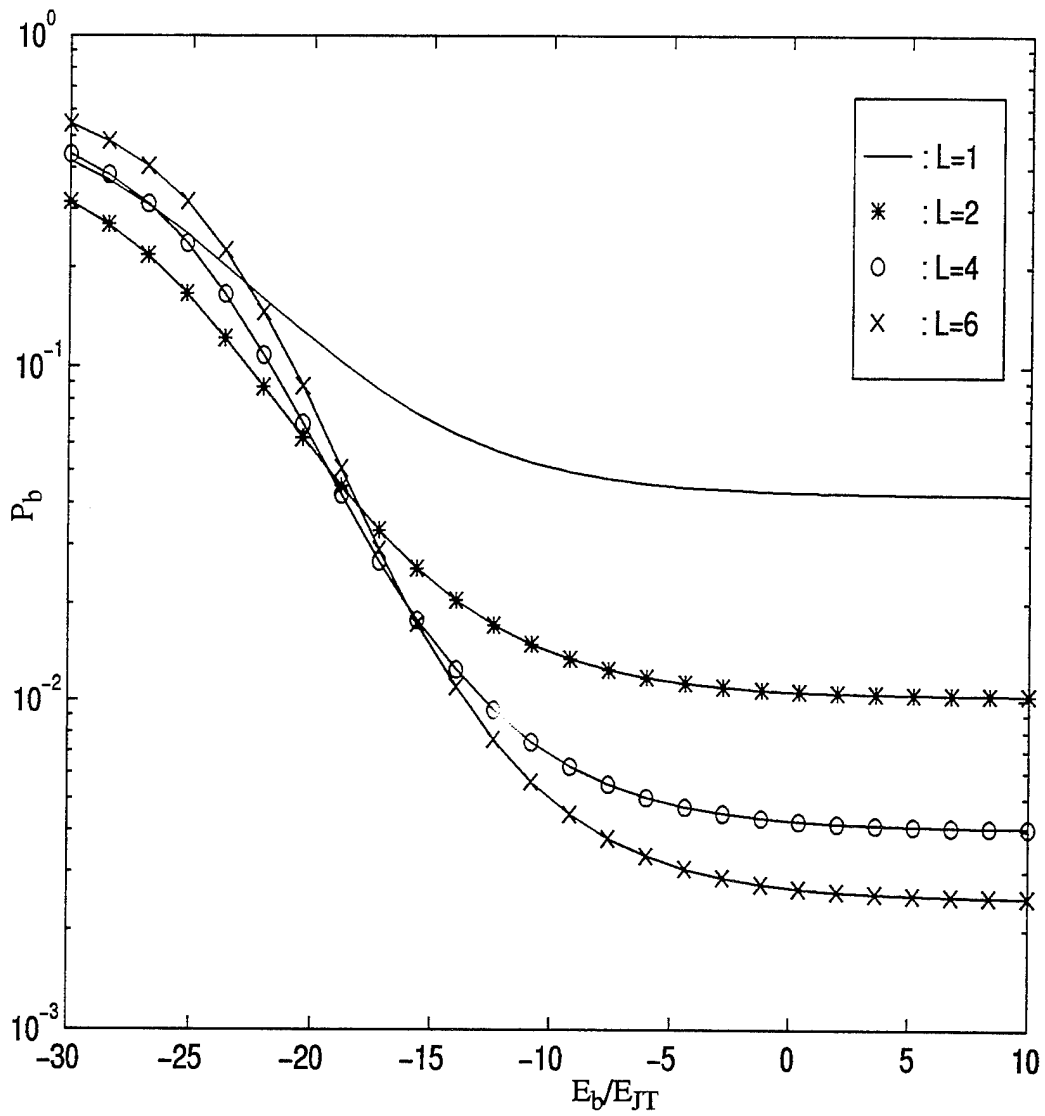

Figure 31: Probability of bit error for Rayleigh-faded signal ($E_b/N_o = 16.35\text{dB}$) and Ricean faded jamming tone ($\rho_J = 10$), for diversity $L = 1, 2, 4, 6$ and actual worst case jamming

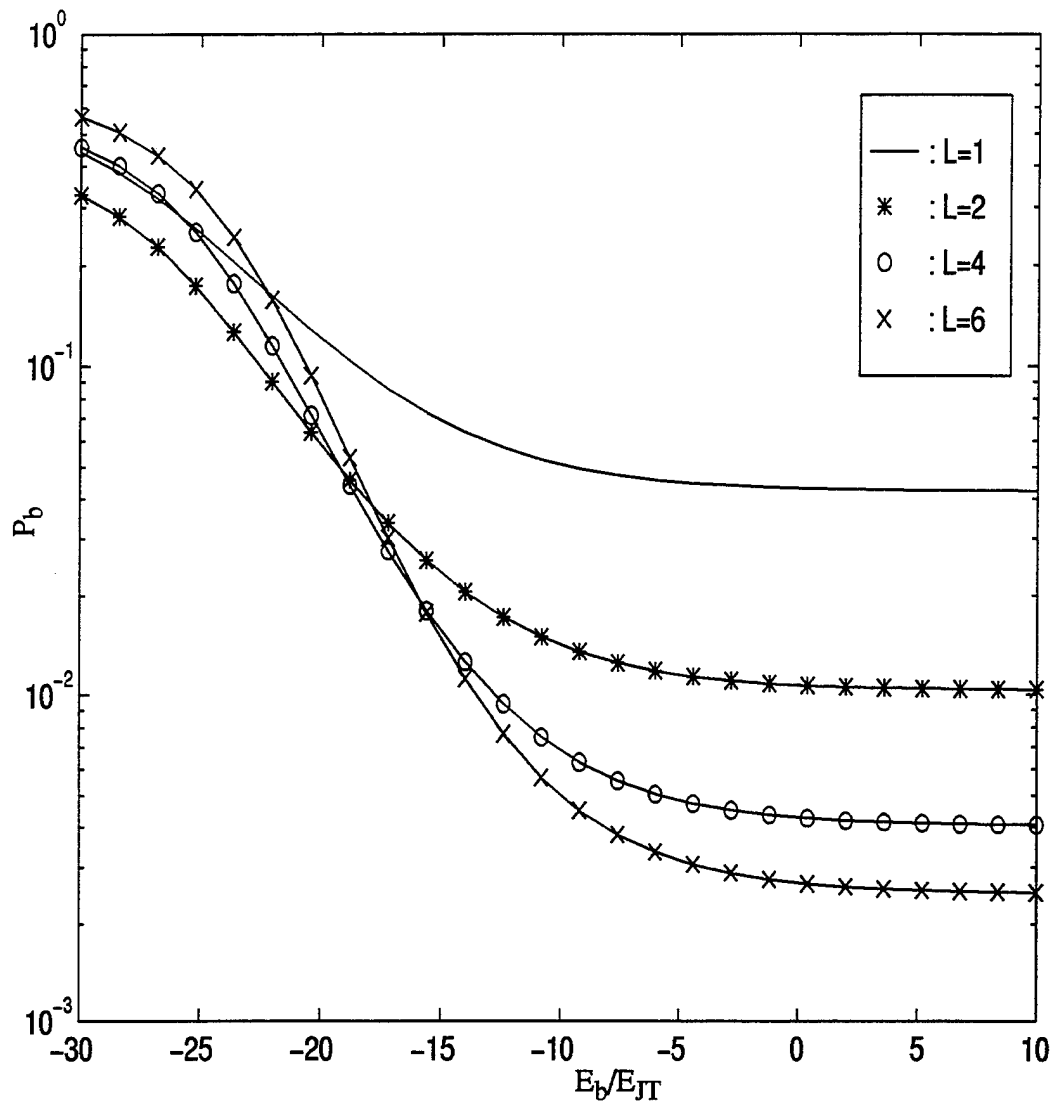

Figure 32: Probability of bit error for Rayleigh-faded signal ($E_b/N_o = 16.35\text{dB}$) and Ricean faded jamming tone ($\rho_j = 100$), for diversity $L = 1, 2, 4, 6$ and actual worst case jamming

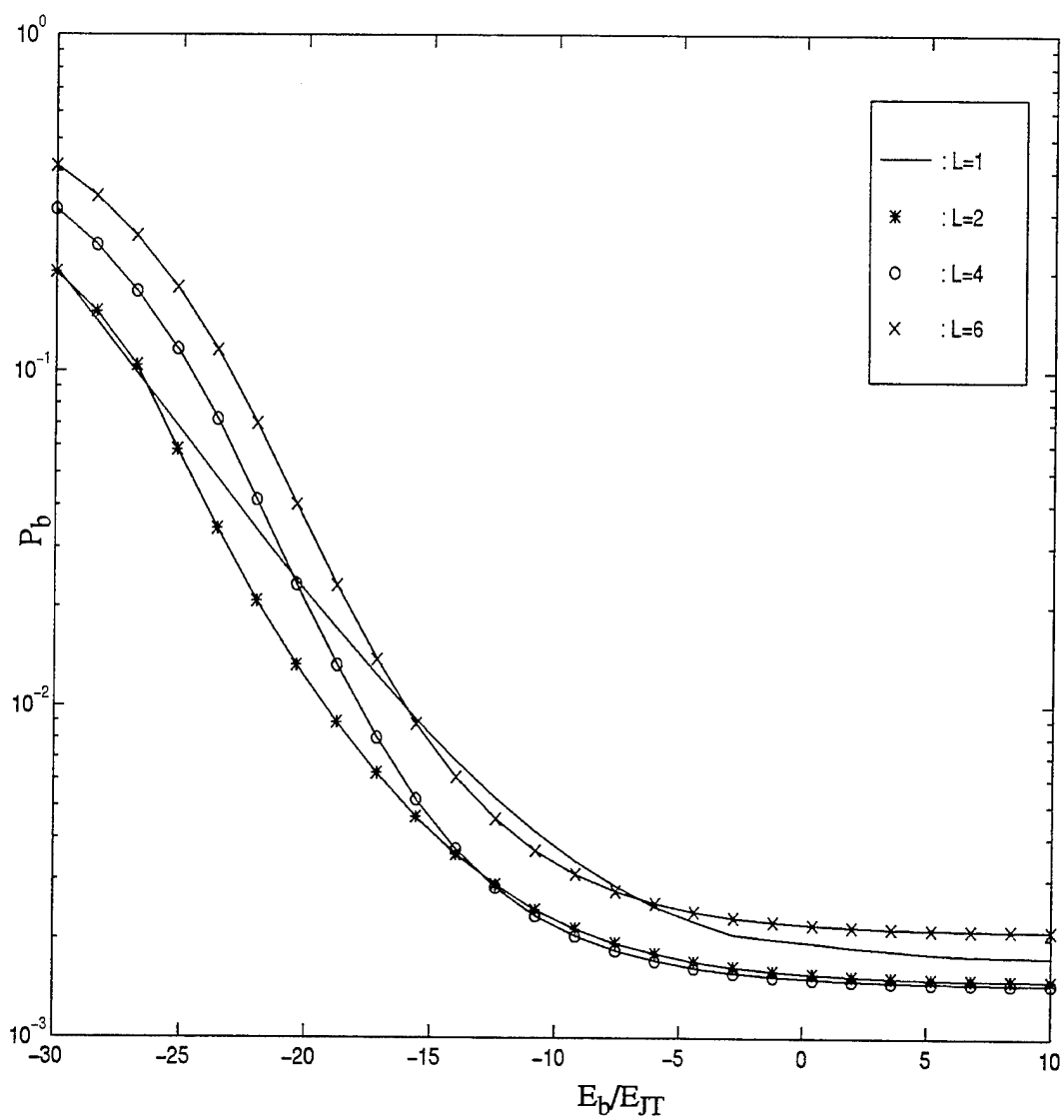

Figure 33: Probability of bit error for Ricean-faded signal ($E_b/N_o = 13.35\text{dB}$), $\rho_c = 10$, and Rayleigh faded jammer for diversity $L = 1, 2, 4, 6$ and actual worst case jamming.

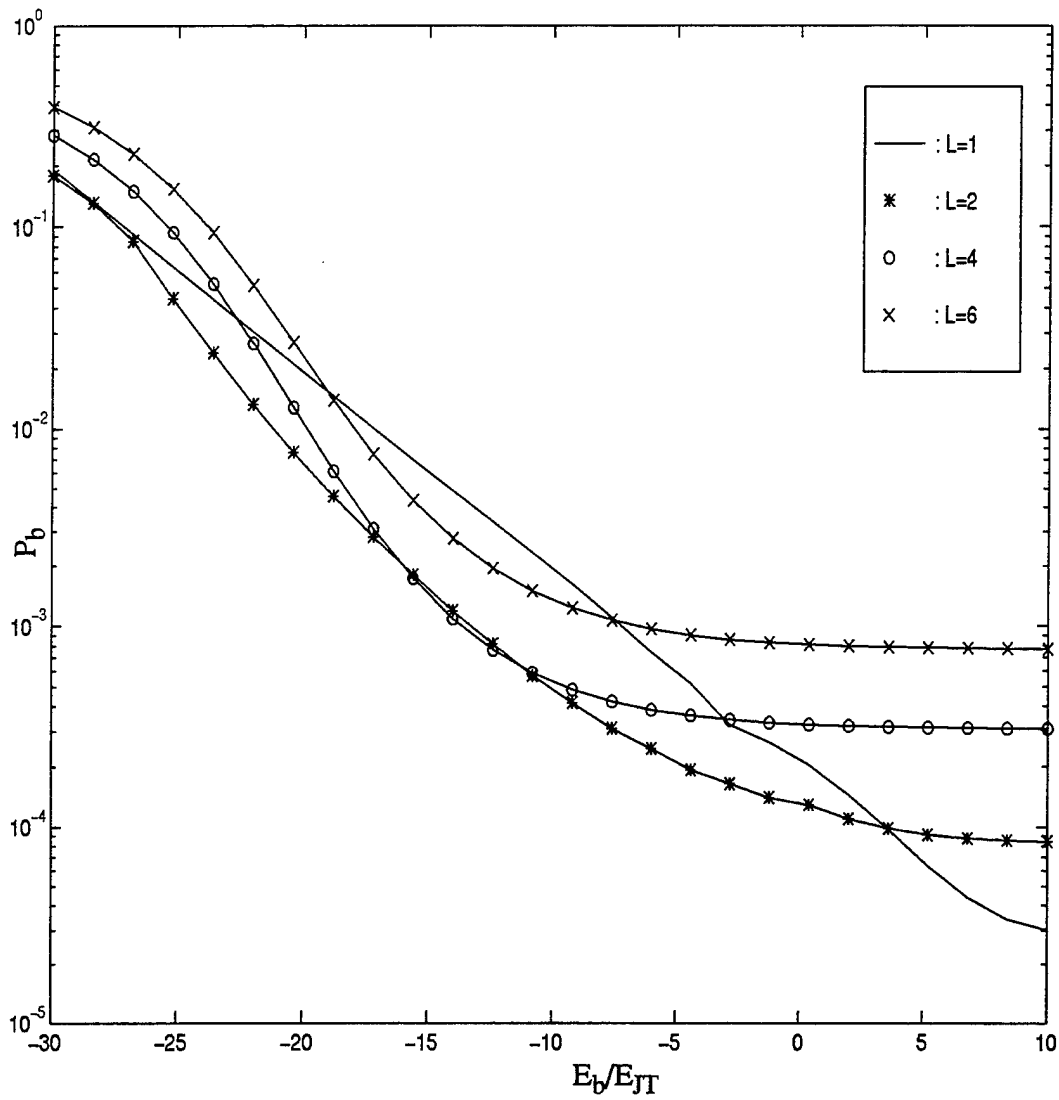

Figure 34: Probability of bit error for Ricean-faded signal ($E_b/N_o = 13.35\text{dB}$)
 $\rho_c = 100$, and Rayleigh faded jammer for diversity $L = 1, 2, 4, 6$ and actual worst case jamming.

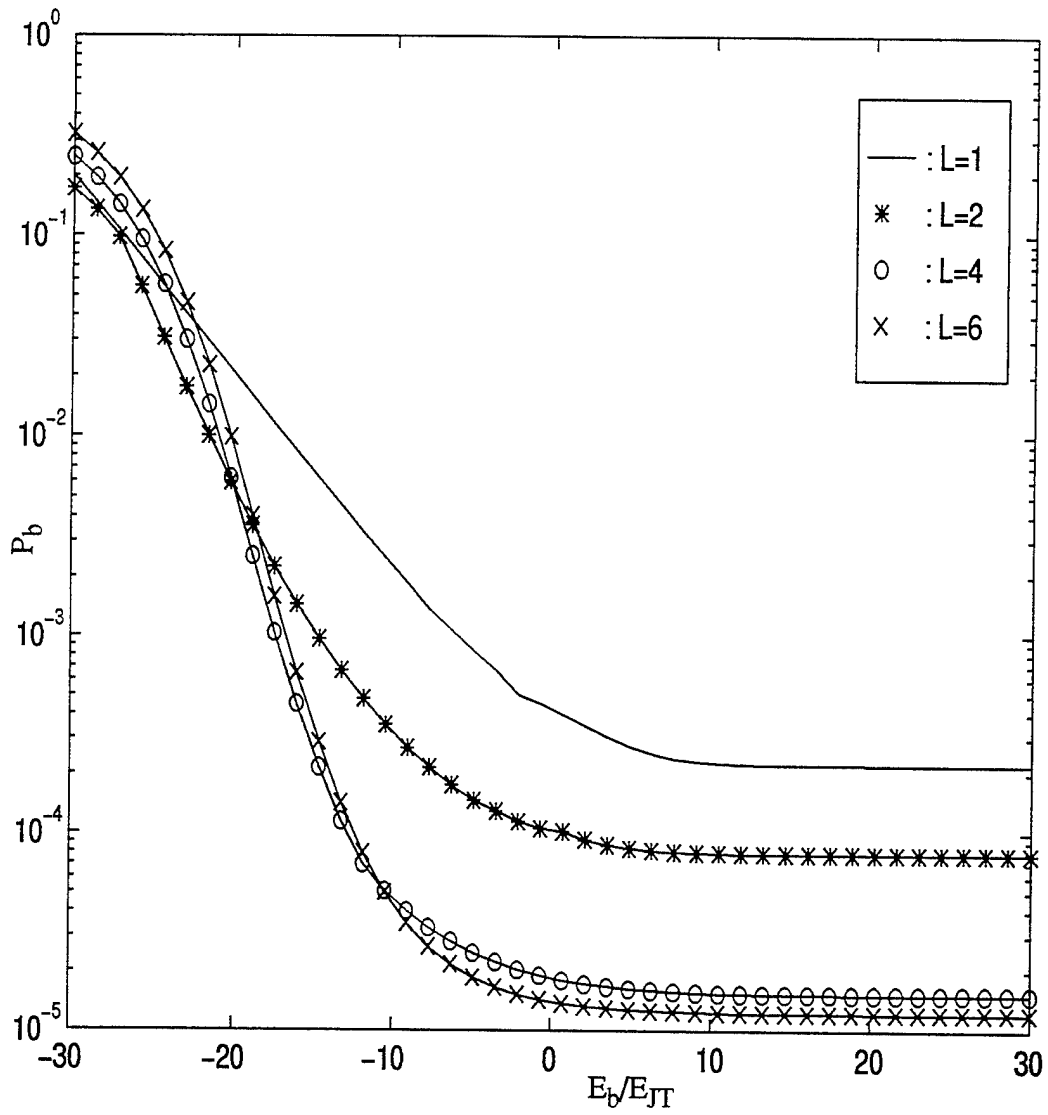

Figure 35: Probability of bit error for Ricean-faded signal ($E_b/N_o = 16.35\text{dB}$), $\rho_c = 10$, and Rayleigh faded jammer for diversity $L = 1, 2, 4, 6$ and actual worst case jamming.

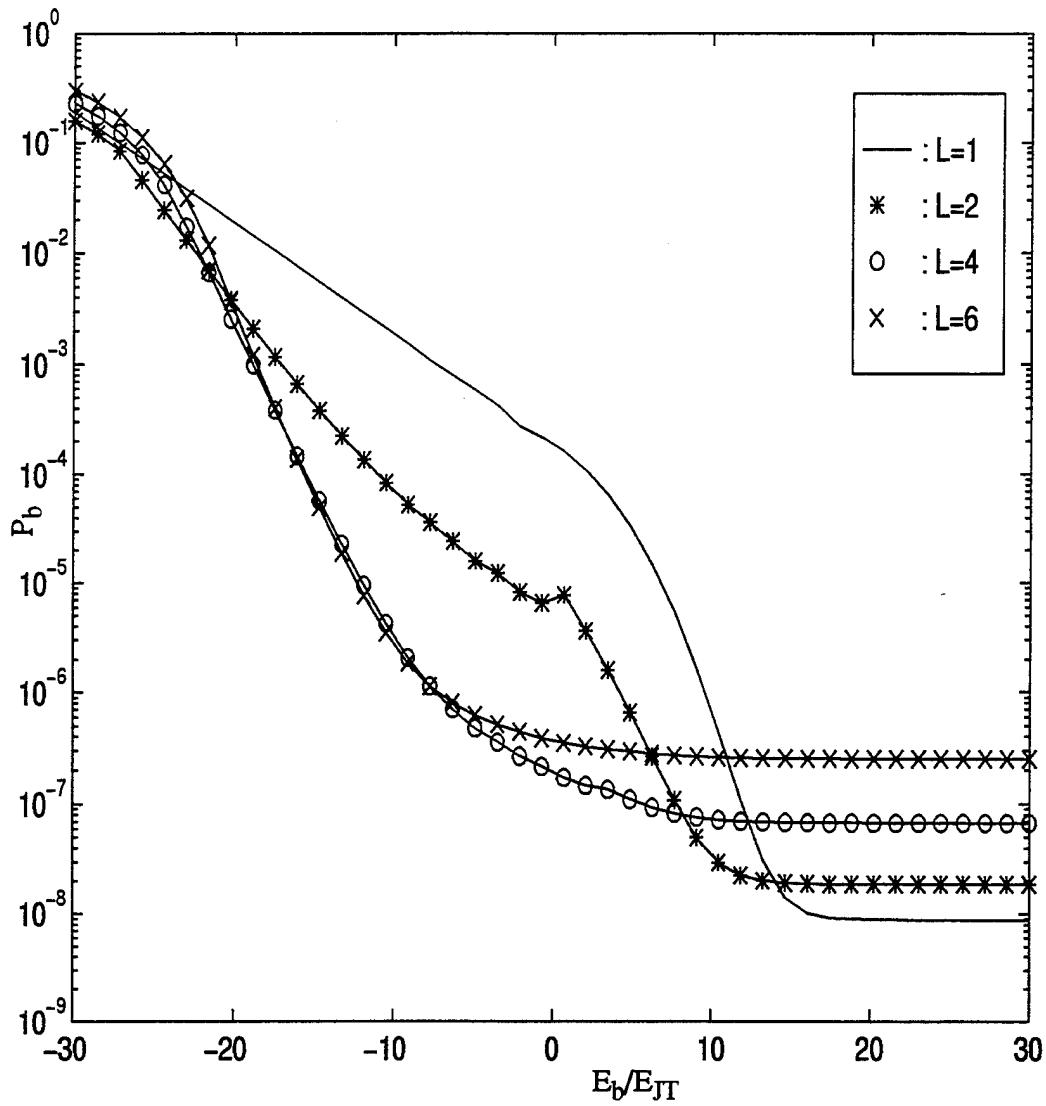

Figure 36: Probability of bit error for Ricean-faded signal ($E_b/N_o = 16.35\text{dB}$)

$\rho_c = 100$, and Rayleigh faded jammer for diversity $L = 1, 2, 4, 6$ and actual worst case jamming.

VI. CONCLUSIONS

This thesis addressed two main questions about the performance of the noncoherent self-normalized FFH/BFSK receiver under conditions of band multitone interference and Ricean fading channels: the question of the most detrimental jamming strategy under various conditions of fading and system diversity, and that of the effect of diversity on the receiver performance. Though finding closed form solutions for the most general case of Ricean fading proved difficult, the results for several special cases of fading provide some information.

It is clear that the degree of fading of the jamming tone has little effect on system performance if the information signal experiences severe fading. When the information signal experiences worst case (Rayleigh) fading, the worst-case jamming strategy simply is to jam all frequency-hop slots. As the information signal channel fading becomes less severe and the hop SNR gets larger, other strategies become more detrimental. When the signal was close to unfaded or the hop SNR was large, a strategy referred to as q_{wc} , (which involved varying the number of frequency-hop slots so that the jamming energy per jammed bin was equal to or slightly greater than the information signal energy per hop) became the actual worst-case strategy. In general, if the jammer knows nothing about the information signal strength and diversity or the degree of channel fading, or if he knows that channel fading is severe, his best choice is jamming 100% of frequency hop slots.

It became clear from comparisons of performance for several cases of diversity and actual worst case jamming that a small diversity ($L = 2$) yielded better performance than no diversity. If the information signal experiences Rayleigh fading and bit energy is less than about 1% of total jamming energy, diversity greater than twofold degrades performance; for the same Rayleigh faded signal and larger ratios of E_b/E_{JT} , performance improved with increased diversity. When the information signal experiences Ricean fading, the effects of diversity are less clear-cut, and depend on the hop SNR and the degree of fading. In general, if the transmitter knows nothing about the degree of channel fading

or the power level of hostile interference, he should choose a small diversity over a larger one. If he suspects that information signal channel fading is severe, and that the available signal energy is greater than about 1% of the available jamming energy, he should choose a higher level of diversity.

It would be interesting to see whether the patterns observed for the special cases of fading channels, with signal and jamming tones affected separately, hold true for more general cases when information and jamming tones are affected more or less equally by fading channels. This could be accomplished through simulations or through numerical evaluation of the general expressions derived in Chapt. II.

LIST OF REFERENCES

1. Gong, K., "Performance of Diversity Combining Techniques for FH/MFSK in Worst Case Partial Band Noise and Multitone Jamming," *Proc. MILCOM'83*, pp. 17-21, October 31-November 2, 1983.
2. Miller, L.E., Lee, J. S., and Kadrichu, A. P., "Probability of Error Analysis of a BFSK Frequency-Hopping System with Diversity Under Partial-Band Jamming Interference - Part III: Performance of a Square-Law Self-Normalizing Soft Decision Receiver," *IEEE Trans. Commun.*, vol. COM-34, no. 7, pp. 669-675, July 1986
3. Robertson, R.C. and Ha, T.T., "Error Probabilities of Fast Frequency-Hopped FSK with Self-Normalization Combining in a Fading Channel with Partial-Band Interference," *IEEE J. Select. Areas Commun.*, vol. 10, no. 4, pp. 714-723, May 1992.
4. Lam, A.W. and Tantaratana, S., *Theory and Applications of Spread-Spectrum Systems: A Self-Study Course*, class text from EC4500, Naval Post Graduate School, Monterey, CA, 1994.
5. Ziemer, R.E. and Peterson, R.L., *Digital Communications and Spread Spectrum Systems*, Macmillan Publishing Company, New York, NY, 1985
6. Proakis, J.G., *Digital Communications*, 2nd ed., McGraw-Hill, Inc., New York, NY, 1989.
7. Levitt, B. K., "Use of Diversity to Improve FH/MFSK Performance in Worst Case Partial Band Noise and Multitone Jamming," *Proc. MILCOMM'82*, vol. 2, pp. 28.2-1-28.2-5, Oct. 1982.
8. Leon-Garcia, A., *Probability and Random Processes for Electrical Engineering*, 2nd ed., Addison-Wesley Publishing Company, New York, NY, 1994.
9. Whalen, A. D., *Detection of Signals in Noise*, Academic Press, Inc., New York, NY, 1971.
10. Gradshteyn, I.S. and Ryzhik, I.M., *Table of Integrals, Series, and Products, Corrected and Enlarged Ed.*, Academic Press, Inc., New York, NY, 1980.
11. Robertson, R.C., "Communications ECCM" class notes from EC4560, Naval Postgraduate School, Monterey, CA.
12. Brigham, E. O., *The Fast Fourier Transform*, Prentice-Hall, Inc, Englewood Cliffs, NJ, 1974.

13. Davis, P.J. and Rabinowitz, P., *Methods of Numerical Integration*, 2nd ed., Academic Press, Inc., Orlando, FL, 1984.
14. Robertson, R.C., "Digital Communications" class notes from EC4550, Naval Postgraduate School, Monterey, CA.

LIST OF SYMBOLS

AWGN - additive white Gaussian noise.

$\sqrt{2}A_c$ - amplitude of information signal, a deterministic value.

$\sqrt{2}a_{ck}$ - the received signal amplitude on the k^{th} frequency hop (of L hops). Modeled as a Ricean random variable.

$\sqrt{2}A_J$ - amplitude of jamming tone.

$\sqrt{2}a_{Jk}$ - the received jamming tone amplitude on the k^{th} frequency hop (of L hops). Modeled as a Ricean random variable.

BFSK - binary frequency-shift keying

E_b - the signal energy per bit. (Equation 1.6)

E_h - the signal energy per hop.

E_J - the jamming energy per frequency-hop slot jammed.

E_{JT} - the total available jamming energy.

f_c - the lowest carrier frequency in the spread-spectrum system bandwidth.

Δf_c - the frequency separation between adjacent hopping frequencies, assumed to be uniform.

f_0 - the information signal frequency corresponding to bit 0.

Δf - the frequency spacing between the information signal tone corresponding to bit 0 and the information signal tone corresponding to bit 1. $\Delta f = 1/T_h$ for minimum orthogonal spacing on the FFH/NC-BFSK system.

FFH - fast frequency-hopped

$f_{Z_1}(z_1 | i, m)$ - the conditional pdf of the random variable Z_1 if i of L hops are jammed, m of the jammed hops correspond to a jamming tone on the signal branch and $(i-m)$ of the jammed hops corresponding to a jamming tone on the non-signal branch.

J - total number of frequency-hop slots. For an M -ary symbol set, each frequency hop slot will contain M signal tones. The slots are numbered from 0 to $J-1$.

L - an integer indicating the number of times per bit interval the carrier frequency changes; diversity level.

N - broadband noise component of the receiver output before normalization.

N_H - total number of frequency hop slots in the spread spectrum system transmission bandwidth

$n_J(t)$ - the total tone jamming signal over the spread spectrum transmission bandwidth. The sum of all the individual jamming tones.

$n_{J_i}(t)$ - the individual jamming tone in the i^{th} frequency-hop slot

$N_0/2$ - the two-sided power spectral density of the AWGN.

$n_T(t)$ - the noise component of the received signal (see Eq. 2.11)

$P_b(L, i)$ - the conditional probability of bit error when i of L hops are jammed.

$P_b(L, i | m)$ - the conditional probability of bit error when i of L hops are jammed with m of the i jammed hops suffering interference on the signal branch and the remaining $(i-m)$ suffering interference on the non-signal branch.

pdf - probability density function.

q - number of frequency-hop slots jammed

Rayleigh fading - a special case of fading in which no signal power is received over the direct path; all signal power is received over the diffuse paths. "worst-case" fading.

R_h - hop rate ($R_h = 1/T_h$).

SJR - signal energy-to-total jamming energy ratio

SNR - signal-to-thermal noise power ratio.

T - bit duration or bit interval.

T_h - hop duration or hop interval.

$u(x)$ - unit step function

X_{1k}, X_{2k} - the outputs of the upper and lower receiver branches, respectively, before normalization. (Refer to Fig. 2)

Z_{1k}, Z_{2k} - the outputs of the upper and lower receiver branches, respectively, after normalization and before summing. (Refer to Fig. 2)

Z_1, Z_2 - the outputs of the upper and lower receiver branches, respectively, after summing. (Refer to Fig. 2)

α_c^2, α_J^2 - average signal power in the direct path portion of the received information signal and jamming tone, respectively. (the special case of $\alpha^2 = 0$ is referred to as Rayleigh fading.)

ζ_c, ζ_J - the average diffuse path power-to-thermal noise power ratio for the information signal and the jamming tone, respectively.

θ_c, θ_J - phase angle of information signal and of jamming tone, respectively. Modeled as random variables uniformly distributed on $[0, 2\pi]$.

ρ_c, ρ_J - ratio of average power received over direct path to that received over the diffuse path for information signal and jamming tone, respectively ($\rho = \alpha^2/2\sigma^2$)

$2\sigma_c^2, 2\sigma_J^2$ - average power in the diffuse path portion of the received information signal and jamming tone, respectively.

σ_N^2 - the noise power per hop at the receiver due to AWGN: $\sigma_N^2 = N_o/T_h$.

Υ_c, Υ_J - the average direct path power-to-thermal noise power ratio for the information signal and the jamming tone, respectively.

ϕ - the phase angle between the received signal tone and the received jamming tone.

$[y]$ - the integer portion of y (where y is some mathematical expression).

Initial Distribution List

- | | | |
|----|---|---|
| 1. | Defense Technical Information Center
Cameron Station
Alexandria, VA 22304-6145 | 2 |
| 2. | Dudley Knox Library, Code 52
Naval Postgraduate School
Monterey, CA 93943-5101 | 2 |
| 3. | Chairman, Code EC
Department of Electrical and Computer Engineering
Naval Postgraduate School
Monterey, CA 93943-5121 | 1 |
| 4. | Prof. R. Clark Robertson, Code EC/Rc
Department of Electrical and Computer Engineering
Naval Postgraduate School
Monterey, CA 93943-5121 | 2 |
| 5. | Prof. Ralph Hippenstiel, Code EC/Hi
Department of Electrical and Computer Engineering
Naval Postgraduate School
Monterey, CA 93943-5121 | 1 |
| 6. | Lt. Mary E. Green
P.O. Box 479
Dahlgren, VA 22448 | 2 |