

NAVAL POSTGRADUATE SCHOOL MONTEREY, CALIFORNIA



THESIS

**STRUCTURAL RESPONSE OF THE SLICE
ADVANCED TECHNOLOGY DEMONSTRATOR**

by

Donald J. Roberts

June, 1995

Thesis Advisor:

Charles N. Calvano

Approved for public release; distribution is unlimited.

19960116 062

DTIC QUALITY INSPECTED

DISCLAIMER NOTICE

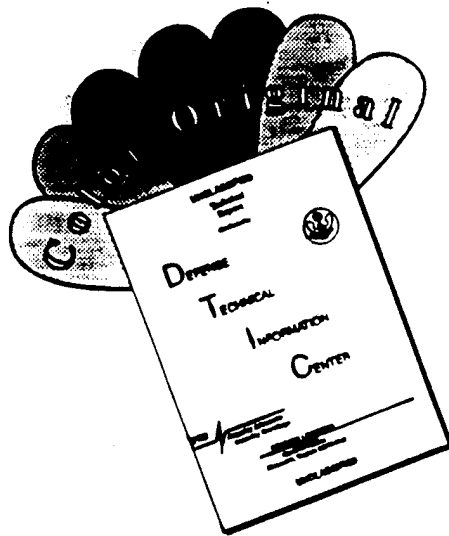

THIS DOCUMENT IS BEST QUALITY AVAILABLE. THE COPY FURNISHED TO DTIC CONTAINED A SIGNIFICANT NUMBER OF COLOR PAGES WHICH DO NOT REPRODUCE LEGIBLY ON BLACK AND WHITE MICROFICHE.

REPORT DOCUMENTATION PAGE

Form Approved OMB No. 0704-0188

Public reporting burden for this collection of information is estimated to average 1 hour per response, including the time for reviewing instruction, searching existing data sources, gathering and maintaining the data needed, and completing and reviewing the collection of information. Send comments regarding this burden estimate or any other aspect of this collection of information, including suggestions for reducing this burden, to Washington Headquarters Services, Directorate for Information Operations and Reports, 1215 Jefferson Davis Highway, Suite 1204, Arlington, VA 22202-4302, and to the Office of Management and Budget, Paperwork Reduction Project (0704-0188) Washington DC 20503.

1. AGENCY USE ONLY (Leave blank)	2. REPORT DATE June 1995	3. REPORT TYPE AND DATES COVERED Master's Thesis	
4. TITLE AND SUBTITLE: STRUCTURAL RESPONSE OF THE SLICE ADVANCED TECHNOLOGY DEMONSTRATOR		5. FUNDING NUMBERS	
6. AUTHOR(S) Roberts, Donald J.		8. PERFORMING ORGANIZATION REPORT NUMBER	
7. PERFORMING ORGANIZATION NAME(S) AND ADDRESS(ES) Naval Postgraduate School Monterey CA 93943-5000		10. SPONSORING/MONITORING AGENCY REPORT NUMBER	
9. SPONSORING/MONITORING AGENCY NAME(S) AND ADDRESS(ES)		11. SUPPLEMENTARY NOTES The views expressed in this thesis are those of the author and do not reflect the official policy or position of the Department of Defense or the U.S. Government.	
12a. DISTRIBUTION/AVAILABILITY STATEMENT Approved for public release; distribution is unlimited.		12b. DISTRIBUTION CODE	
13. ABSTRACT (maximum 200 words) The objective of this research was to provide the Office of Naval Research (ONR) with an independent evaluation of the structural adequacy of Lockheed's SLICE hull design. SLICE is an offshoot of the SWATH ship technology, with four lower hulls instead of the SWATH's twin hulls. An advanced finite element code was used in the dynamic and static analysis of the SLICE's unique hull form. This thesis demonstrates the practical value of utilizing finite element modeling as a tool in modern ship design.			
14. SUBJECT TERMS SLICE, SWATH, Finite Element Modeling			15. NUMBER OF PAGES 61
			16. PRICE CODE
17. SECURITY CLASSIFICATION OF REPORT Unclassified	18. SECURITY CLASSIFICATION OF THIS PAGE Unclassified	19. SECURITY CLASSIFICATION OF ABSTRACT Unclassified	20. LIMITATION OF ABSTRACT UL

Approved for public release; distribution is unlimited.

**STRUCTURAL RESPONSE OF THE
SLICE ADVANCED TECHNOLOGY DEMONSTRATOR**

Donald J. Roberts
Lieutenant Commander, United States Navy
B.S., United States Naval Academy, 1980

Submitted in partial fulfillment
of the requirements for the degree of

MASTER OF SCIENCE IN MECHANICAL ENGINEERING

from the

NAVAL POSTGRADUATE SCHOOL

June 1995

Author:

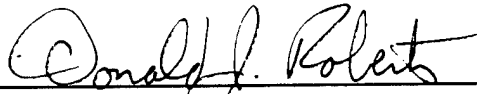

Donald J. Roberts

Approved by:



Charles N. Calvano, Thesis Advisor



Matthew D. Kelleher, Chairman
Department of Mechanical Engineering

ABSTRACT

The objective of this research was to provide the Office of Naval Research (ONR) with an independent evaluation of the structural adequacy of Lockheed's SLICE hull design. SLICE is an offshoot of the SWATH ship technology, with four lower hulls instead of the SWATH's twin hulls. An advanced finite element code was used in the dynamic and static analysis of the SLICE's unique hull form. This thesis demonstrates the practical value of utilizing finite element modeling as a tool in modern ship design.

Accession For		
NTIS	CRA&I	<input checked="" type="checkbox"/>
DTIC	TAB	<input type="checkbox"/>
Unannounced		<input type="checkbox"/>
Justification		
By		
Dist:ibution /		
Availability Codes		
Dist	Avail and/or Special	
A-1		

Original contains color plates: All DTIC reproductions will be in black and white

TABLE OF CONTENTS

I. INTRODUCTION.....	1
A. BACKGROUND.....	1
B. DESCRIPTION OF THE SLICE ADVANCED TECHNOLOGY DEMONSTRATOR (ATD).....	2
C. HYDRODYNAMIC LOADS ON SWATH SHIPS.....	4
1. Primary Loads.....	4
2. Secondary Loads.....	5
D. SCOPE OF RESEARCH.....	6
II. FINITE ELEMENT MODELING.....	7
A. BASIC DESCRIPTION.....	7
B. OVERVIEW OF FINITE ELEMENT MODELING USING I-DEAS.....	8
C. MODEL SOLUTION.....	10
1. Normal Mode Analysis.....	10
2. Linear Static Analysis.....	11
D. POST-PROCESSING.....	12
III. MODEL DEVELOPMENT.....	13
A. PHYSICAL AND MATERIAL PROPERTIES.....	13
B. MESH GENERATION OF THE SLICE	17
1. Node and Element Creation.....	17
2. Model Components.....	18
a. Transverse Bulkheads	18
b. Stiffened Hull Plating	18
C. MESH QUALITY CHECKS	21
D. BOUNDARY CONDITIONS.....	22
IV. DISCUSSION OF RESULTS.....	25
A. NORMAL MODE ANALYSIS.....	25
1. First Mode.....	25

2. Second Mode	25
3. Third Mode.....	26
4. Fourth Mode.....	26
B. LINEAR STATIC ANALYSIS.....	26
1. Load Case One (Prying Force).....	26
2. Load Case Two (Squeezing Force).....	31
3. Load Case Three (Racking Force Forward/Prying Force Aft).....	31
V. RECOMMENDATIONS AND CONCLUSIONS.....	45
A. RECOMMENDATIONS.....	45
B. CONCLUSIONS.....	45
APPENDIX. SLICE ATD WEIGHT STATEMENT SUMMARY.....	47
LIST OF REFERENCES.....	49
INITIAL DISTRIBUTION LIST.....	51

I. INTRODUCTION

A. BACKGROUND

Design of naval vehicles has long been an art passed down from generation to generation. Structural design rules of the various classification societies have evolved through years of operational experience. Because of the complexity of hydrodynamic loads, hull structural designs have relied heavily upon static analysis as modified by empirical data to account for actual dynamic conditions. Although this traditional approach to hull design has proved to be adequate, it does not efficiently utilize material consistent with the loads and failure modes hulls need to resist. With the quantum increase in computing power made available during recent years, there is no longer any reason not to overhaul these traditional methods and to incorporate the latest technology into new ship designs.

The basic hull structure of a ship must be designed to resist yielding, fatigue and buckling throughout its service life. A finite element analysis of the structure using expected hydrodynamic loading conditions allows the designer the flexibility to effectively vary structural member sizes (scantlings) throughout the ship, based upon the resultant stresses and stress concentrations. This dynamic approach allows an optimum structural weight distribution and minimizes the opportunity for structural failure. The limitation to such an approach is the current lack of available data to accurately predict sea wave spectra throughout the life of a ship; however, this same limitation also plagues the traditional design approach.

A lack of historical data makes the finite element model approach especially appropriate when considering radically different hull forms as opposed to the conventional monohull. This requirement has become increasingly evident over the past several decades with the growing use of the Small Waterplane Area Twin Hull (SWATH) ship design. This innovative hull form requires new hydrodynamic pressure load criteria since the existing methods developed for monohull ships do not apply. Unlike the

limiting longitudinal loading condition which causes hogging and sagging in monohulls, the primary wave loads acting on the SWATH's submerged hulls and water piercing struts are in the transverse direction. The remainder of this paper demonstrates these principles with a novel ship design known as the SLICE, a variant of the SWATH design.

B. DESCRIPTION OF THE SLICE ADVANCED TECHNOLOGY DEMONSTRATOR (ATD)

The SLICE Advanced Technology Demonstrator (ATD) is a unique surface ship hull form designed by Lockheed Missiles and Space Company (Marine Systems Division) and sponsored by the Office of Naval Research (ONR). The design concept for SLICE is an offshoot of the Small Waterplane Area Twin Hull (SWATH) ship technology developed during the past three decades. Its unique hull form consists of four submerged "torpedo-like" lower hulls or pods connected by means of struts to the main cross structure located above the water's surface. The forward pair of eight foot diameter hulls is inset by three feet with respect to the aft pair. Figure 1 depicts the outboard profiles and principal dimensions of the SLICE ATD.

The primary advantage of the SLICE/SWATH over conventional monohulls is its enhanced seakeeping ability; this is especially true in heavy seas. Buoyancy is predominantly provided by the fore and aft set of hulls which remain well below the water's surface, effectively isolating the ship from the dynamic buoyancy effects of waves. The ship's four water piercing struts present a much smaller waterplane area than a conventional monohull of similar displacement which make it less sensitive to wave actions. Other advantages include [Ref. 2]:

- Reduced deck wetness
- Reduced wave slamming
- Increased crew effectiveness and safety in high sea states
- Ability to maintain speed in high sea states

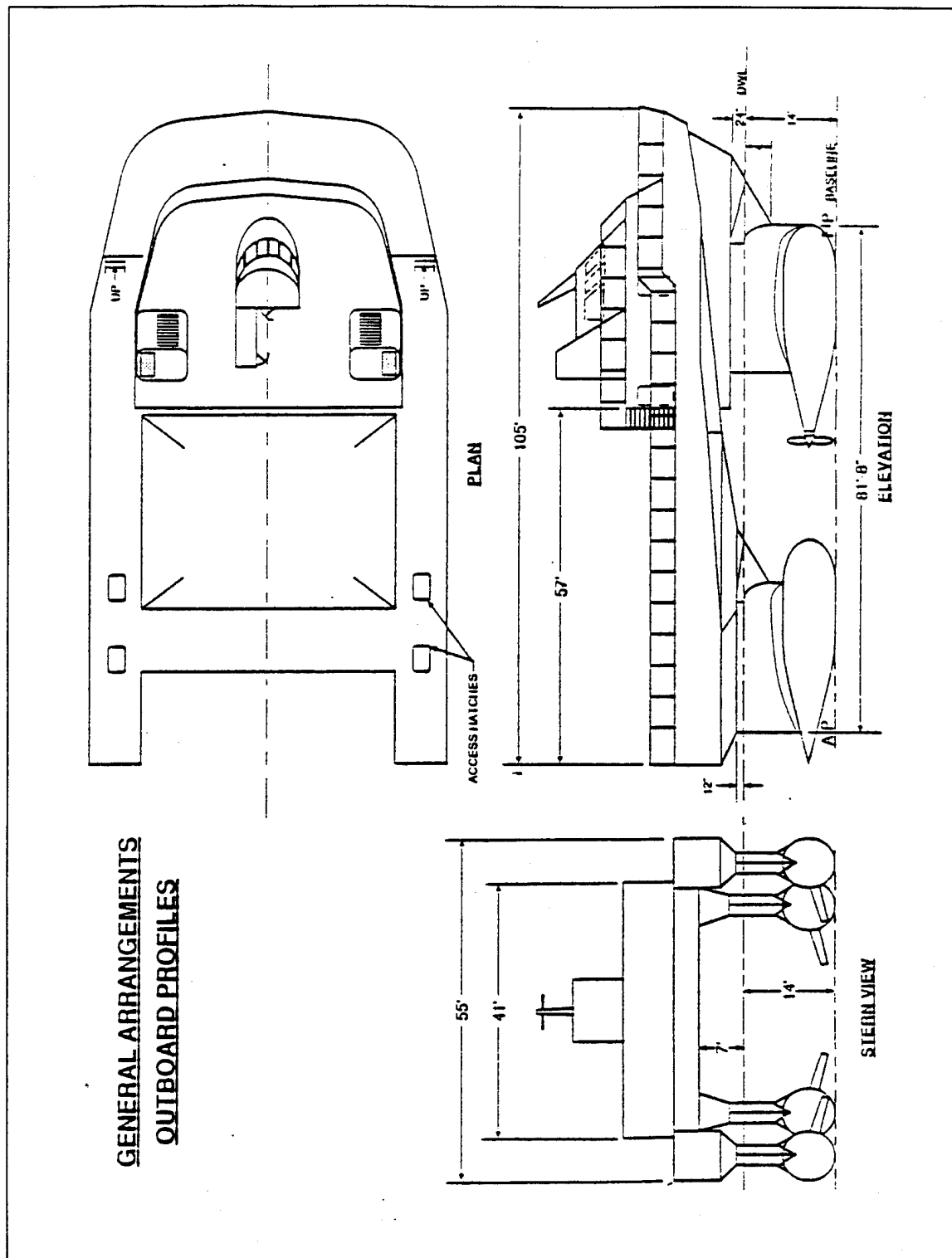

Figure 1. Outboard Profile and Principal Dimensions of the SLICE ATD, from Ref. [1]

Despite its superior seakeeping ability, the SWATH ship is not without limitations. Because of its small waterplane area, the SWATH displays hydrostatic properties markedly different from a monohull's. Its typical tons-per-inch immersion (TPI) is 15-30 percent that of a similarly displaced monohull's TPI. Similarly, its moment-to-change trim one inch (MTI) is 10-20 percent that of a monohull's. Consequently, due to its increased sensitivity to weights and moments, the SWATH's displacement and weight distribution becomes an important factor during the preliminary design process. [Ref. 3]

C. HYDRODYNAMIC LOADS ON SWATH SHIPS

1. Primary Loads

The structural configuration of SWATH ships is strongly influenced by the hydrodynamic forces of waves. The passage of waves creates a variable pressure distribution that is generally different on its twin hulls (or the four hulls of a SLICE). A typical pressure distribution resulting from beam seas is shown in Figure 2. The resultant forces from these waves are maximum in beam seas, approximately 50-60 percent of maximum in bow or quartering seas, and small in head and following seas. These forces which alternately pry the hulls apart and squeeze them together are the primary hull girder loads for SWATH ships. The magnitude of the alternating transverse side forces generated varies with the seas encountered and hull form selected; however, measurements and model tests have shown that they are comparable in size to the displacement of the ship. [Ref. 3]

Due to a phenomenon known as shear lag, the transverse bulkheads and adjacent shell plating must absorb most of the shear and bending moments caused by the primary loads. Since the shell plating between the bulkheads is much more flexible than the transverse bulkheads in the athwartships direction, it provides little resistance to the

wave induced forces. Consequently, the placement and configuration of transverse bulkheads becomes a critical factor in the design of SWATH ships. [Ref. 3]

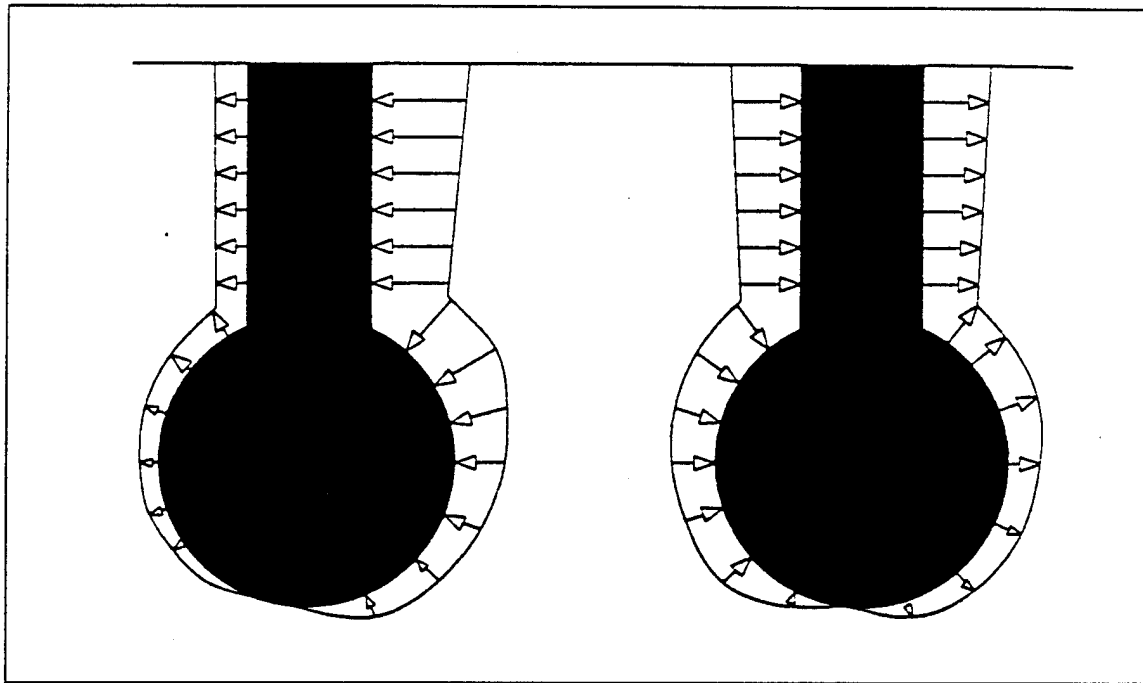

Figure 2. Primary Load Pressure Distribution in Beam Seas, from Ref. [3]

2. Secondary Loads

The principal types of secondary loads a SWATH ship encounters are wet deck slamming and strut side slamming. Slam pressure loads are local in nature and occur at all locations on the wet deck; however, they are generally most severe at the ends due to the ship's pitch motion. Prediction of strut side slamming is difficult due to complexity of flow near the hull. Very little data has been collected to date concerning slam pressures on SWATH ships which make this a difficult area to analyze. [Ref. 3]

D. SCOPE OF RESEARCH

This thesis documents the method used in the development of the finite element based representation of the SLICE ATD hull. An advanced finite element code called I-DEAS (Integrated Design Engineering Analysis Software) developed by Structural Dynamics Research Corporation is utilized as a design tool for the analysis. The software is used to solve for the normal modes of oscillation as well as the linear static response of the SLICE ATD finite element model. Subsequent chapters will discuss the theory behind finite element modeling, model development and design decisions, analysis results, conclusions and suggestions for further research.

II. FINITE ELEMENT MODELING

A. BASIC DESCRIPTION

Finite Element Analysis (FEA) is a numerical process used to approximate displacements and stresses within a structure. The method involves dividing a complex structure into a grid of discrete elements. Each element consists of a simple polygon for which the finite element program assembles a set of governing equations in the form of stiffness and mass matrices. The unknowns for each element consist of the displacements at the "nodes" or points at which the elements are connected together. There will be one equilibrium equation written for each nodal degree of freedom; Equation (1) illustrates the equations of motion for a dynamic system in matrix form. Given the known forces, structure stiffness, structure mass, viscous damping and boundary conditions, the equations of motion can be solved to yield the displacement at the nodes. The stresses in each element can then be calculated from the nodal displacements. [Ref 4]

$$[M]\{\ddot{q}\} + [C]\{\dot{q}\} + [K]\{q\} = \{F\} \quad (1)$$

where $[M]$ = mass matrix, $[C]$ = viscous damping matrix, $[K]$ = stiffness matrix, $\{q\}$ = generalized nodal displacement vector, $\{\dot{q}\}$ = generalized nodal velocity vector, $\{\ddot{q}\}$ = generalized nodal acceleration vector, and $\{F\}$ = nodal force vector.

Finite Element Modeling (FEM) is the process of creating a structure through the use of these nodes and elements. The finite element model is a mathematical representation of a structure and may not necessarily look like the actual structure. Different types of elements are used to model the various parts of the structure including thin shell, beam, solid, rigid and lumped mass elements. The accuracy of the results will depend upon the proper selection and combination of these element types. Additionally, the assumptions made for loads, boundary conditions, and material properties significantly affect the accuracy of the solution. In general, the solution will

be more accurate as the model is subdivided into smaller elements; however, solution accuracy does not come without a price. The price you must pay comes in the form of increased computer processing time and data storage requirements which often don't justify the need for an incremental increase in accuracy. The art of finite element modeling is, therefore, to discretize the structure into an appropriate number of finite elements to provide adequate accuracy without using an excessive number of elements. It is up to the modeler to apply sound engineering judgement when selecting element types, material properties, loads, and boundary conditions in order to gain useful insight into the response of a complex structure.

B. OVERVIEW OF FINITE ELEMENT MODELING USING I-DEAS™

I-DEAS™ (Integrated Design Engineering Analysis Software) is an integrated package of mechanical engineering software tools used for solid modeling, drafting, and finite element simulation. FEM using I-DEAS is an iterative process with three main stages [Ref 5]:

- *Pre-processing* includes developing the model geometry, assigning physical and material properties, applying loads and boundary conditions, and checking the model quality.
- *Solving* the model is done in the I-DEAS Model Solution Task. I-DEAS Model Solution can perform linear and non-linear statics, dynamics, and buckling analysis. The model information can also be exported to several popular external finite element solvers for analysis.
- *Post-processing* involves plotting deflections and stresses, and comparing the results to predetermined failure criteria. I-DEAS shows the results in different display formats- deformed geometry, contour plots, and others- to give insight into how to improve the design. Post-processing also allows the engineer to check for errors which may not have been detected during the model building process.

Figure (3) represents the sequential steps required to complete the FEM process using I-DEAS. Details on the pre-processing stage are included in Chapter III. Details on solving and post-processing the model are discussed in the following section.

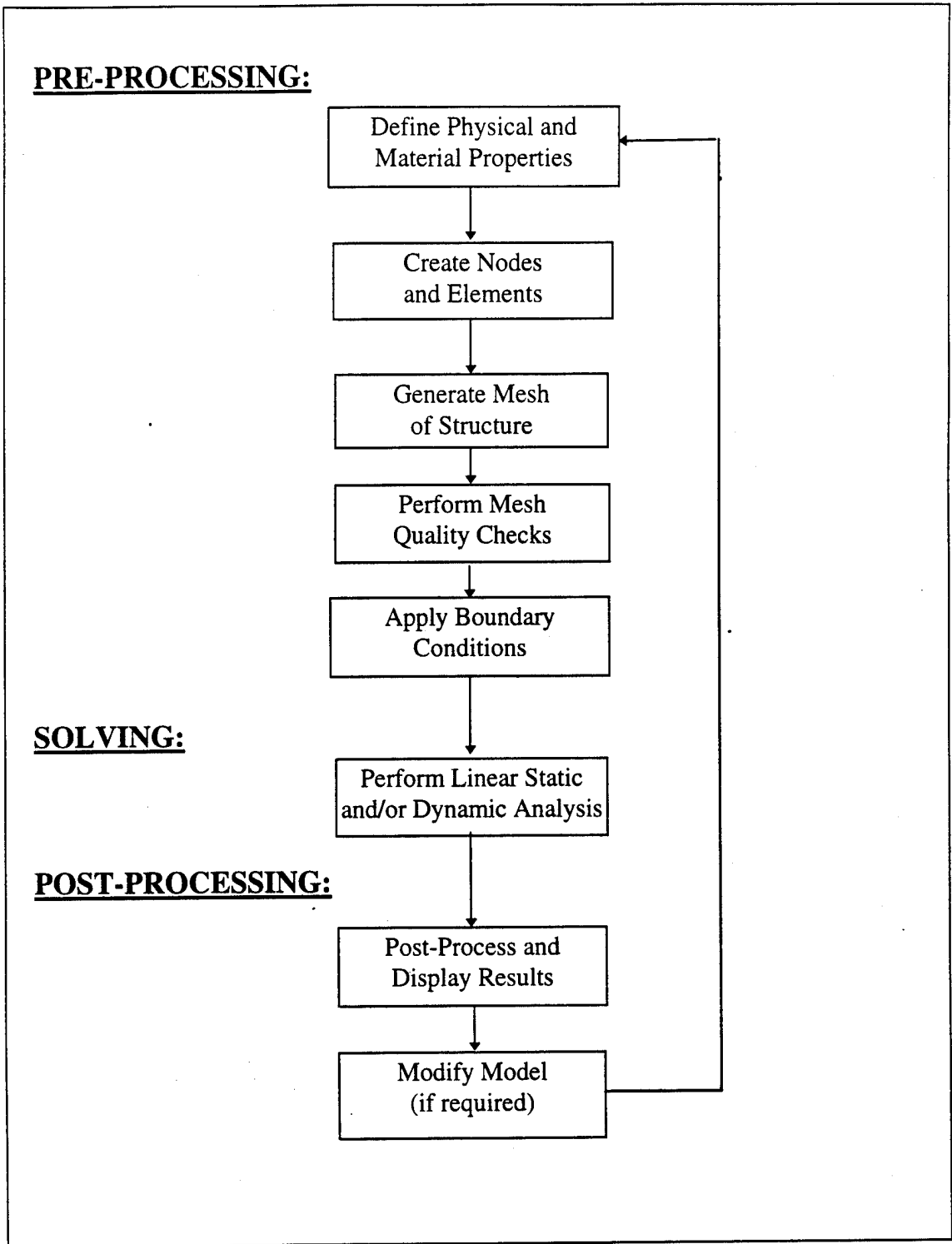

Figure 3. The FEM Process, after Ref [5]

C. MODEL SOLUTION

The I-DEAS Model Solution Task is an integrated finite element structural analysis solver which can be used for both dynamic and linear static analysis. Both of these analysis techniques provide valuable insight into the response of complex structures.

1. Normal Mode Analysis

Normal Mode analysis is a technique for predicting the undamped natural frequencies and mode shapes of vibration for a structure. Mode shapes and natural frequencies can be used to identify transient load points and frequencies which may generate undesirably large structural responses to dynamic inputs. The response of structures can often be assumed to be a combination of the mode shapes corresponding to the lowest natural frequencies. [Ref 6]

In the absence of damping and external forces for a multi-degree-of-freedom system, the equations of motion reduce to:

$$[M]\{\ddot{q}\} + [K]\{q\} = \{0\} \quad (2)$$

The solution to this set of second-order differential equations is not an easy task, even when the equations are linear with constant coefficients. This is because the equations are dependent upon one another through coupling terms and must be solved simultaneously. The equations of motion are typically coupled through stiffness or mass terms, known as elastic and inertial coupling, respectively. By transforming the physical coordinate system to one which diagonalizes the stiffness and mass matrices simultaneously, the equations of motion can be uncoupled both elastically and inertially. Such coordinate systems do exist and are known as natural coordinates. The process of diagonalizing the matrices is sometimes referred to as modal decomposition. Once the

diagonalized matrices are obtained, the solution becomes one of solving for n independent homogeneous equations, where n is the number of degrees of freedom (DOF) for the system. The general motion of an undamped linear system can then be represented as a linear combination of its natural modes of vibration. [Ref 7]

The I-DEAS Model Solution Task has three different algorithms available to solve for natural frequencies and mode shapes. These are: Simultaneous Vector Iteration (SVI), Guyan Reduction, and the Lanczos method. All three methods use some form of modal decomposition to obtain the results. The SVI method was chosen for use in this thesis due to its efficiency when working with a large DOF system. [Ref 5]

2. Linear Static Analysis

The more traditional approach to finite element analysis is through the use of linear statics. Linear statics is a technique used to predict the displacement of a structure when a static load is applied within the elastic range of the structure's material properties. It uses the principle of virtual work to equate the virtual work of external forces and moments to the virtual work of internal stresses. Once the nodal displacement of the finite element model is known, other important parameters such as stress can be calculated. The equations of motion in matrix form for linear statics are simply:

$$[K]\{q\} = \{F\} \quad (3)$$

Again, the number of equations corresponds to the number of DOF for the system. [Ref 6]

To obtain reasonable results for a linear static analysis, proper boundary conditions must be applied to the structure. A boundary condition set consists of both restraints and loads. Improperly restraining a structure can lead to misleading and erroneous results. A model must be restrained against all six rigid body modes (three translations and three rotations). If rigid body motion is a possibility in a structure (as in

a ship or other vehicle), it must be restrained using kinematic degrees of freedom. Kinematic degrees of freedom act to restrain a vehicle in space when no physical restraints exist. [Ref 4]

Finally, the results of the normal mode analysis can be used to help identify probable limiting load cases for use in a linear static analysis. External forces may be obtained from existing data bases such as data obtained from model or full scale tests of similar structures.

D. POST-PROCESSING

Post-processing is the visual display and interpretation of data from the model solution stage. Two of the most valuable displays available within I-DEAS are the contour plot and the deformed geometry plot. Contour plots display the distribution of results using contour lines and bands of color representing the data. This is especially useful when evaluating the stress distribution in a structure. Deformed geometry plots display the model in its deformed condition, i.e., as if the displacements were bending the model. Because most deformations are small compared to the size of the model, the displayed deformations are magnified by a scaling factor to allow for meaningful interpretation of data. [Ref 5]

Another useful feature of I-DEAS is its ability to animate the results. Animation gives the illusion of motion to the deformed geometry by successively stepping through a series of frames, starting with the undeformed geometry and ending with the 100% deformed configuration. This provides valuable insight when evaluating the mode shapes of a structure. [Ref 5]

III. MODEL DEVELOPMENT

The purpose of this chapter is to describe the development of the SLICE ATD finite element model used for this study. The important design decisions and engineering simplifications used during construction of the model will be discussed. The finite element model of the SLICE hull was created by using Lockheed's detailed design drawings as a reference. Figure 4 shows the profile and main deck view from these drawings. Figure 5 shows similar views of the completed SLICE finite element model for comparison. An isometric view of the completed model is illustrated in Figure 6.

A. PHYSICAL AND MATERIAL PROPERTIES

Before creating elements, the physical and material properties of the elements must be defined. Physical properties are the geometric properties of an element. The only physical property varied for this model was the element thickness, which varied from 0.09 inches for the non-tight (NT) floors to 0.75 inches for the main transverse beams.

Material properties are those properties which are unique to a specific material. They include Young's Modulus, yield strength, Poisson's ratio, and material density. The hull structure of the SLICE is to be constructed from 5083-H32 Aluminum for plates and 5083-H112 Aluminum for shapes. Material properties are listed below in Table 1.

Material Type	5083-H32	5083-H112
Elastic Modulus	10.3×10^6 psi	10.3×10^6 psi
Yield Strength (min)	31,000 psi	24,000 psi
Poisson's Ratio	0.33	0.33
Density	.096 lbm/in ³	.096 lbm/in ³

Table 1. Material Properties of 5083 Aluminum, from Ref [8]

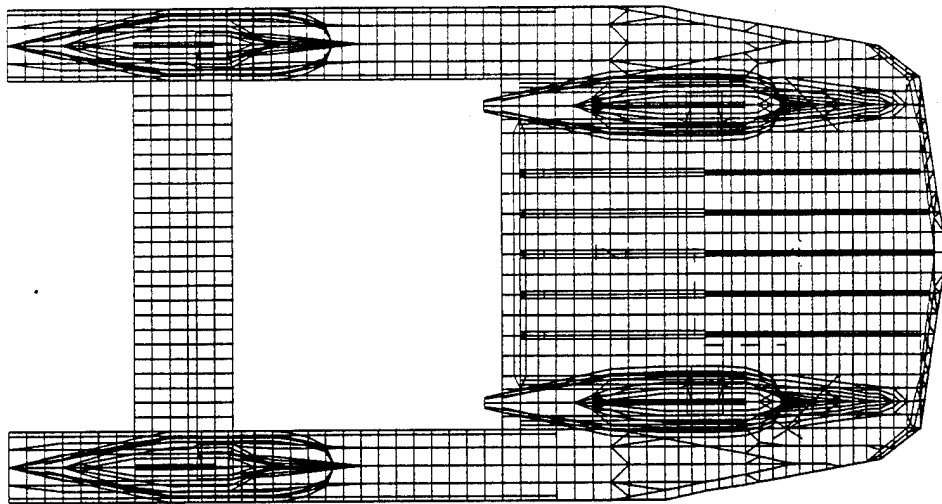

Overhead View (with Hidden Lines Shown)

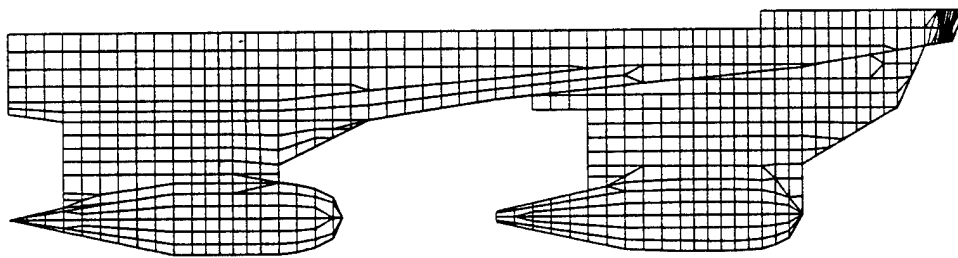

Profile (without Hidden Lines)

Figure 5. Finite Element Model of the SLICE

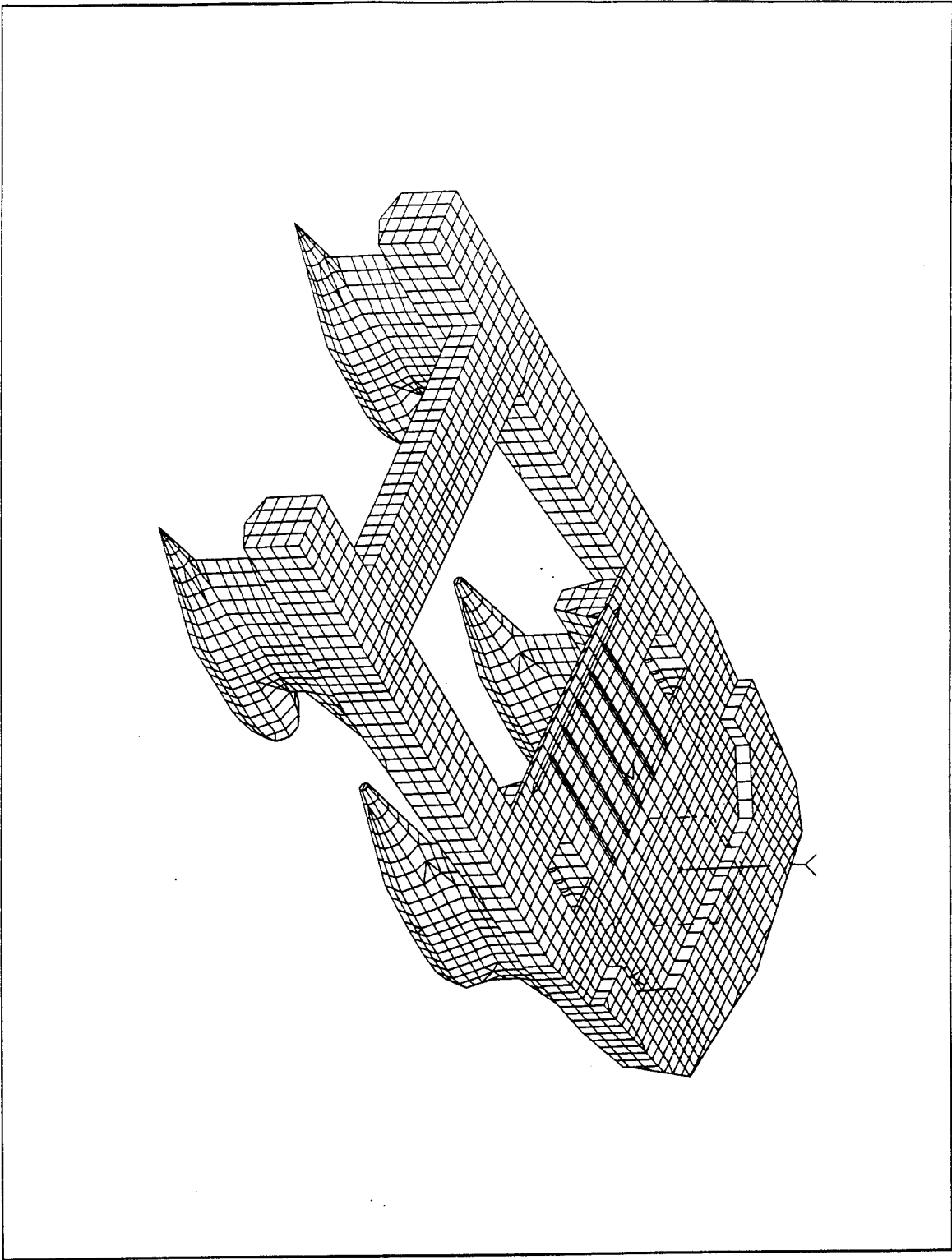

Figure 6. Isometric View of the SLICE Model

B. MESH GENERATION OF THE SLICE

1. Node and Element Creation

Each node is a point located in 3D space where elements are connected, loads are applied, and restraints are imposed. Each node has up to six degrees of freedom, depending on the type of element used. Nodes are located such that the geometry of the model approximates that of the actual structure. Nodes for the SLICE model were generated manually by keying in their coordinates or by copying and reflecting existing nodes. Each transverse frame (see Figure 4) of the SLICE was modeled as a set of nodes. [Ref 4]

Prior to generating any elements, the decision was made to construct the basic hull form from thin shell linear quadrilateral and triangular elements. Thin shell elements can be used to accurately represent a structure whose thickness is small with respect to its other dimensions. No one element type is best for all situations; however, thin shell elements most closely model the response of stiffened hull plating. Although cubic and parabolic elements provide more accuracy than linear elements, the small gain in solution accuracy was not deemed necessary for this study. Linear elements have two nodes along each edge, parabolic have three, and cubic have four. [Ref 4]

Once the nodes are generated, the elements can be created. Each element is created by sequentially selecting a set of three or four nodes; i.e., three nodes for a triangle or four nodes for a quadrilateral. Adjacent elements share a pair of common nodes; thereby forming a "grid" or "mesh" of elements representing the components of the actual structure.

Once the basic hull form was completed, lumped masses were added to the model to account for nonstructural mass components not represented by the thin shell elements. These include the propulsion plant, the payload structure, the deck house, the auxiliary machinery, and fuel oil. The Appendix contains a summary of the SLICE ATD weight distribution. The lumped masses were connected to the thin shell elements through a

network of rigid elements. Rigid elements are massless, infinitely stiff members used to distribute the mass loading of the lumped masses.

In summary, the SLICE ATD finite element model contains 10,262 nodes, 11,562 linear thin shell elements, 456 rigid elements, and 23 lumped mass elements. The model has 58,875 degrees of freedom.

2. Model Components

a. Transverse Bulkheads

The transverse bulkheads provide the main structural strength for the SLICE. The SLICE contains multiple transverse bulkheads; however, only two bulkheads provide its primary load carrying capacity. These primary bulkheads are referred to as the forward and aft spars which are located at frames 6 and 35, respectively (see Figure 4). The SLICE incorporates a unique design in the construction of these two bulkheads, henceforth referred to as the forward and aft spars. Each spar employs use of a tapered I-beam which is curved by 90 degrees as shown in Figure 5. The flange thickness of the curved beam is 0.75 inches. Its web thickness varies from 0.50 inches at the curve or haunch area to 0.25 inches at the ship centerline and strut. The longitudinal girder shown in Figure 4 has a flange and web thickness of 0.25 inches. The model's thin shell element thickness was varied to reflect these dimensions.

b. Stiffened Hull Plating

The hull plating was modeled using 0.25 inch thin shell elements. The plating is strengthened through the use of both transverse and longitudinal stiffeners. To minimize the degrees of freedom of the model, the smaller stiffeners' cross sections (i.e., those with a depth of 6 inches or less) were idealized as a wedge shape vice the typical Tee

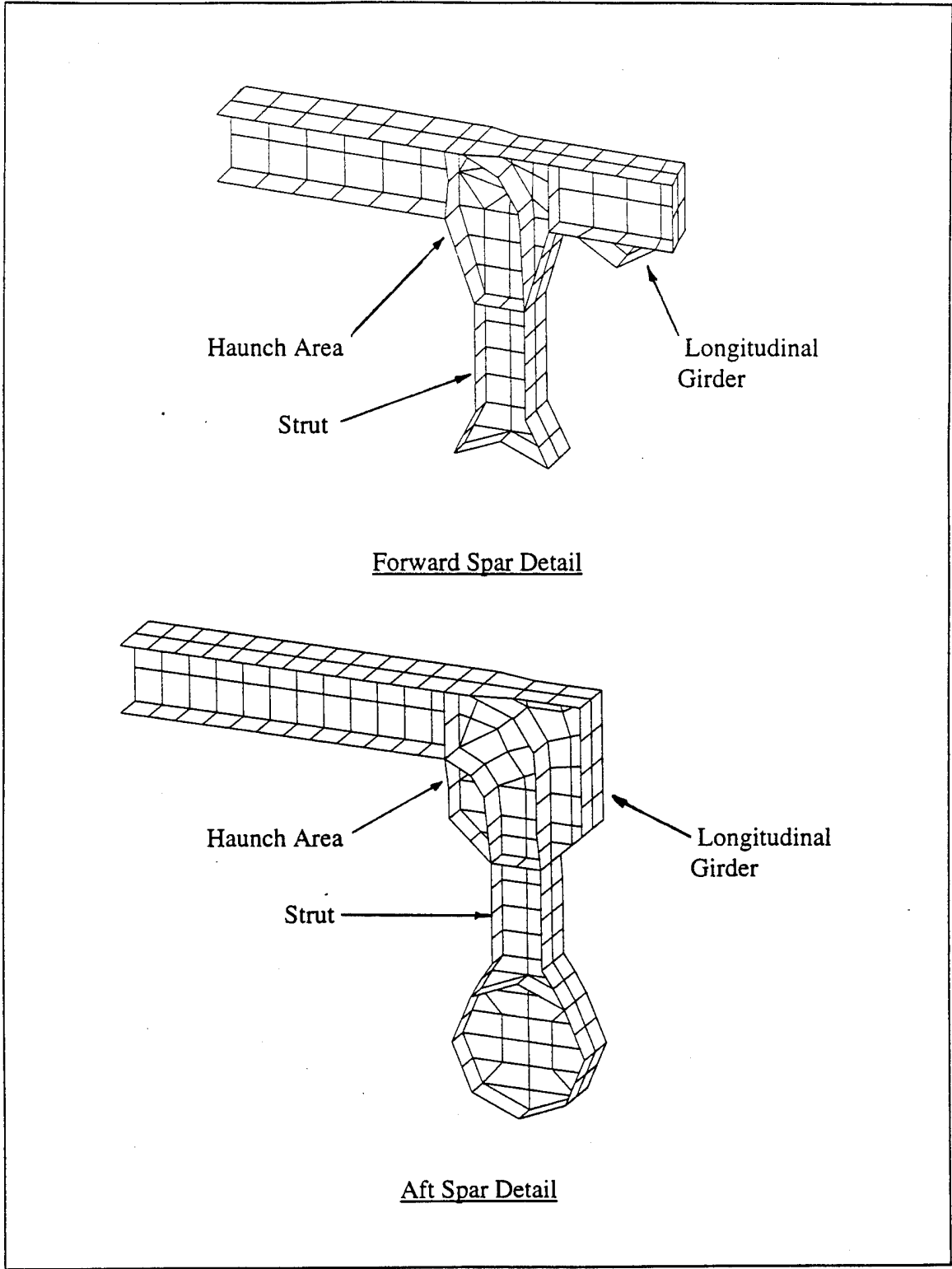

Figure 7. SLICE's Primary Transverse Bulkheads

shape. This was done by matching the moment of inertia (in the direction of bending) and the center of gravity of the wedge to that of the corresponding Tee. Figure (8) illustrates this concept. A typical section of stiffened hull plating is shown in Figure (9).

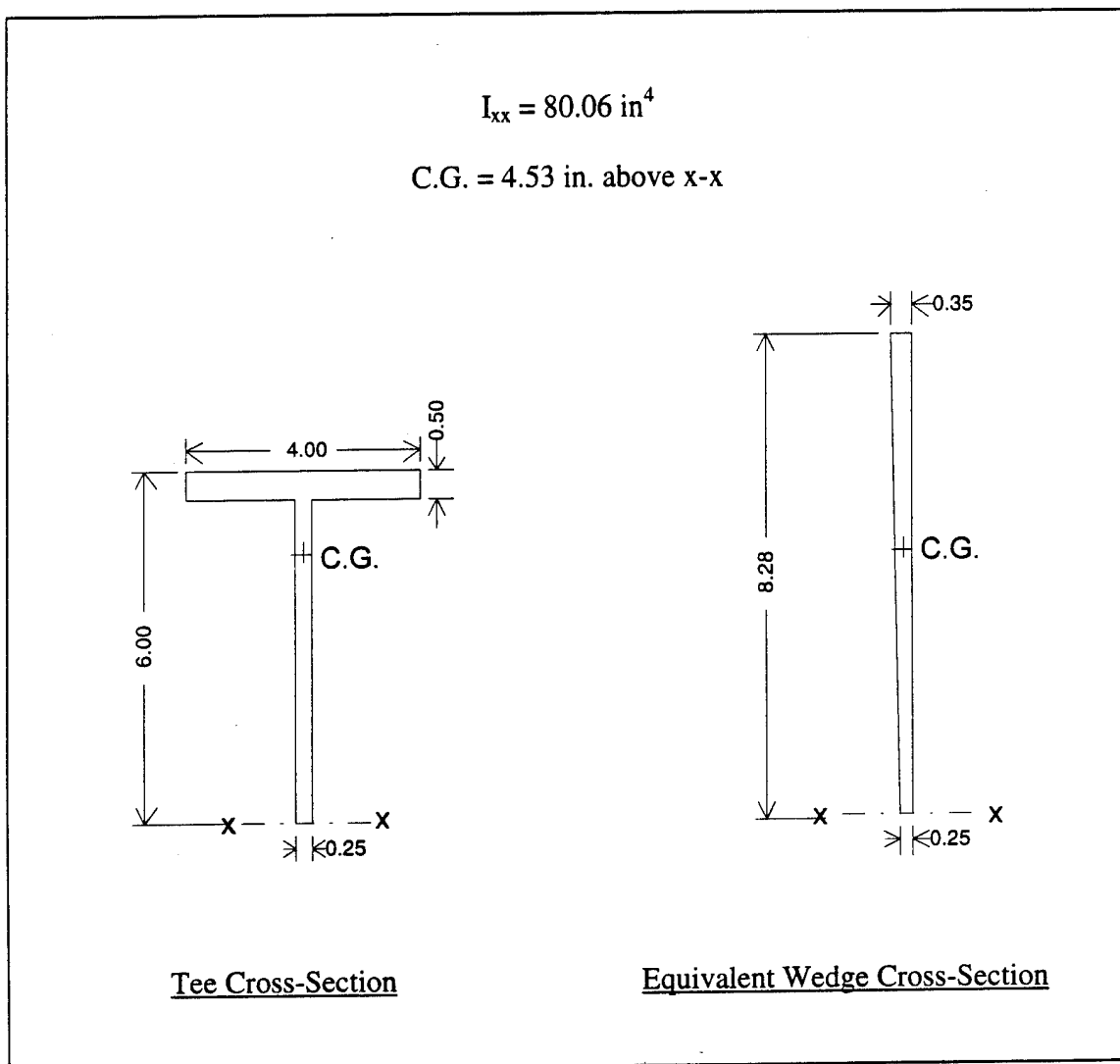

Figure 8. Idealization of Tee Shaped Stiffeners

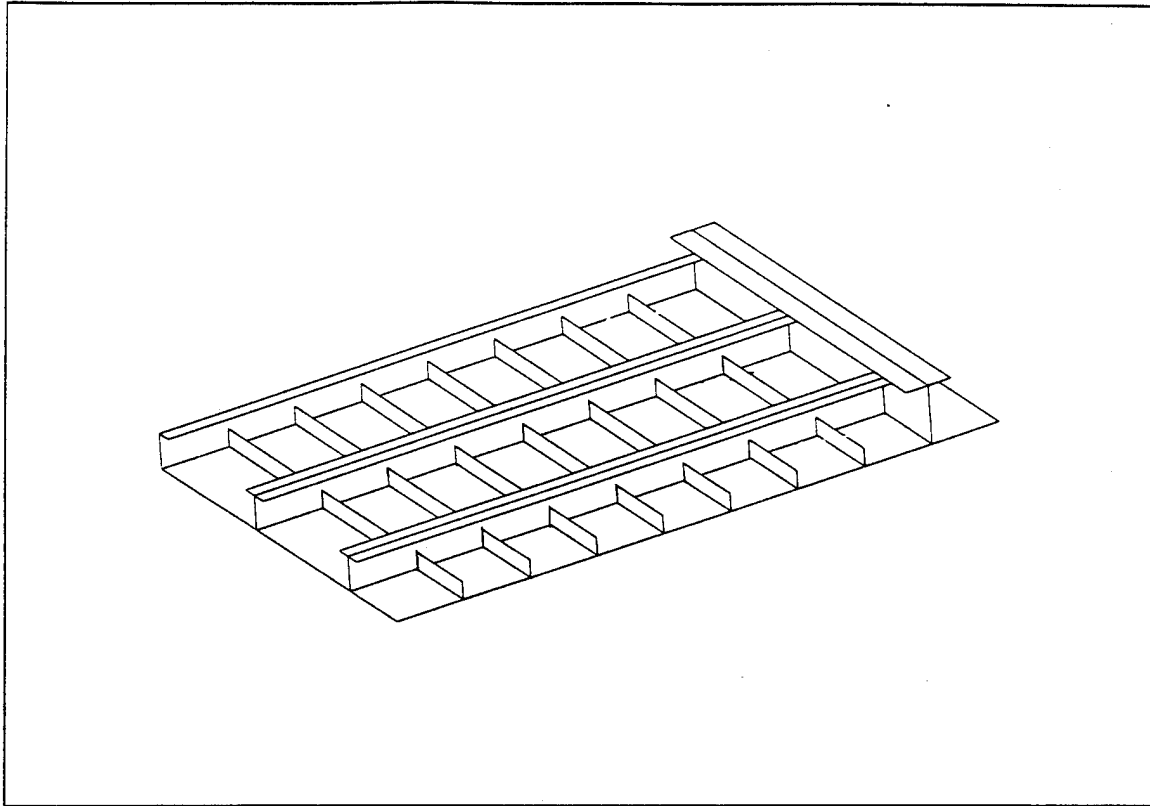

Figure 9. Stiffened Hull Plating of Forward Main Deck

C. MESH QUALITY CHECKS

I-DEAS contains several mesh quality checks to help identify modeling errors. Typical errors which can be checked include element connectivity problems, highly distorted elements, and duplicate nodes or elements. [Ref 4]

The free edge check plots the free edge of elements which are not connected to other elements. Normally, this plots only the outer boundary of the model; however, if elements are not properly joined, an extra line will appear when conducting this check. This represents a “crack” or flaw in the model. [Ref 4]

A second useful check is the element distortion check. In finite element modeling, a “perfect” element is represented by a square or equilateral triangle. Any

deviation from this ideal condition results in a distorted element. Highly distorted elements should be avoided, especially in important areas such as high stress locations. [Ref 4]

Finally, I-DEAS can check for coincident nodes and elements. This feature is especially important when building large or complex models. Having duplicate nodes or elements can produce erroneous data or cause the finite element program to fail.

D. BOUNDARY CONDITIONS

Prior to solving the finite element model, boundary conditions must be applied. Boundary conditions can consist of both restraints and structural loads. For the Normal Mode Analysis, only restraints are used. Even if a model has rigid body motion, it must be held in space by restraints so that it is not free to move in any direction. Restraints are applied at individual nodes and can have up to six values at each node, three translations and three rotations. In the case of the SLICE, six rigid body modes are possible; therefore, the model must be immobilized by a minimum of six restraints referred to as kinematic degrees of freedom. A total of nine translations were selected at three separate nodes to ensure the model was sufficiently restrained. [Ref 4]

For the Linear Static Analysis, structural loads are required in addition to the restraints. For the SLICE model, structural loads include gravitational forces, buoyancy forces and hydrodynamic loads due to waves. Gravitational forces are distributed throughout the model and vary depending upon the individual mass of each element. Buoyancy forces are distributed around each of the four submerged hulls at nodes which are close to the ship's center of buoyancy.

By far the most complex forces to simulate are those due to the sea. One useful method available to predict the maximum lifetime load for SWATH ships is presented in references [11] and [12]. This method develops a design side load algorithm which predicts the single maximum side force a SWATH ship would experience during a

20 year lifetime in the North Atlantic Ocean. A summary of the algorithm developed in references [11] and [12] is presented here. The units of displacement are Ltons and the lengths are in normalized units of feet divided by the cube root of displacement (Feet/Ltons^{1/3}).

$$F = DTL\Delta \quad (4)$$

where F = Maximum Lifetime Side Load (Ltons)

Δ = Displacement (Ltons)

D = Size Factor = $4.474 - 0.913 \cdot \text{Log}(\Delta)$

L = Length Factor = $0.75 + 0.35 \cdot \tanh(0.5 \cdot L_s - 6)$

where L_s = Strut Length (Feet/Lton^{1/3})

[for tandem strut vessels, L_s is the sum of the forward and aft strut lengths]

T = Draft Factor = $0.5319 \cdot \text{Draft}$ (Feet/Lton^{1/3})

Inputting the appropriate SLICE parameters into Equation (4) yields a maximum lifetime side force of approximately 280 Ltons. This side load is overestimated for small SWATH ships that are restricted to coastal operations because of the assumption of a maximum wave height of 50 feet used to derive the algorithm [Ref 3]. A reduced initial estimate of a 200 Lton side force was used for this study; however, further analysis needs to be performed to refine this value.

Another finite element study determined that the variations in side load distribution had relatively little effect upon the stresses in SWATH structures [Ref 13]. Variations in the loading redistributed themselves throughout the structure [Ref 13]. The distribution of side forces and buoyancy forces chosen for the current study is illustrated using the aft starboard hull in Figure 10. A trapezoidal side force distribution was assumed with the resultant force centered about the mid-draft level.

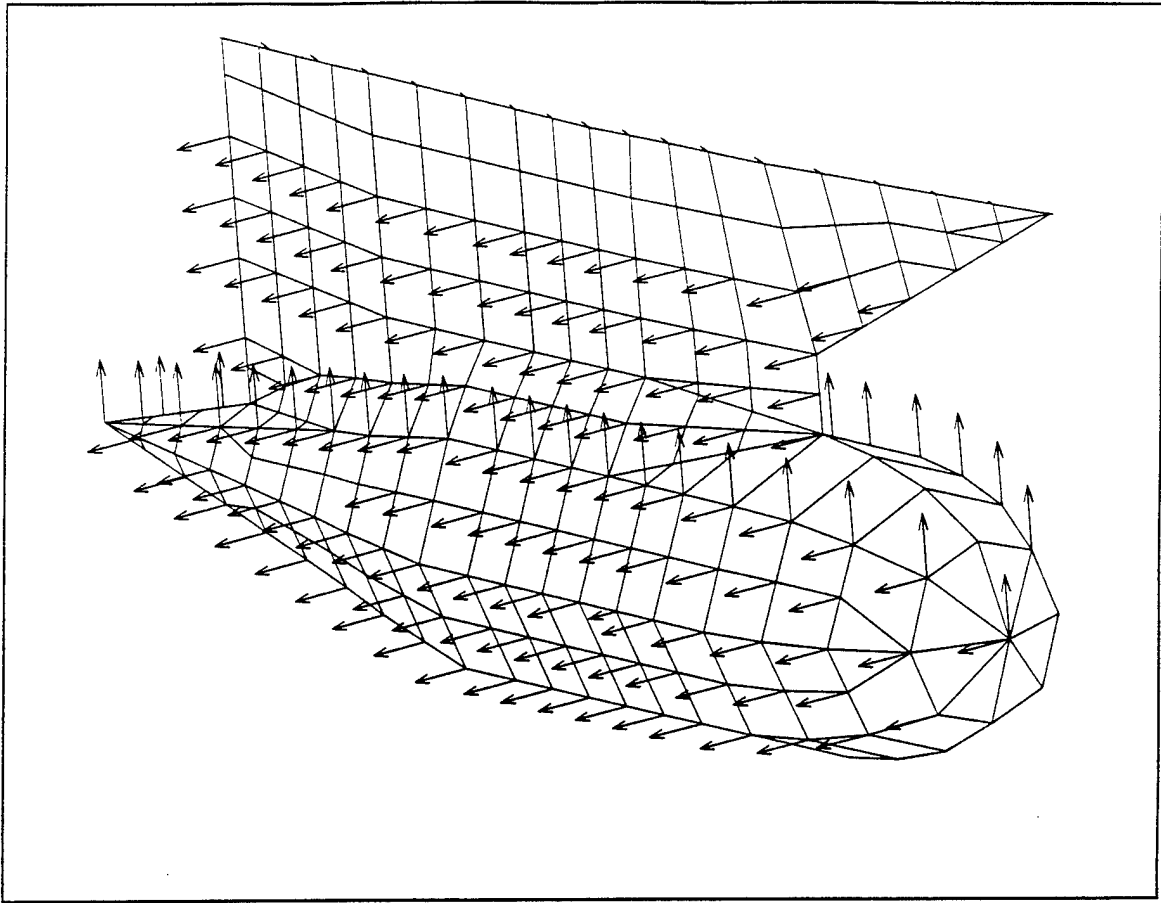

Figure 10. Typical Distribution of Side Forces and Buoyancy Forces
(Note: Arrows represent direction and not magnitude)

IV. DISCUSSION OF RESULTS

A. NORMAL MODE ANALYSIS

The SLICE model's first four flexible modes were solved using the Simultaneous Vector Iteration (SVD) method of I-DEAS' Model Solution Task. The mode shapes were evaluated in the Post-Processing Task using I-DEAS' animation feature. A brief description of each is provided here.

1. First Mode

The first mode occurs at a natural frequency of 4.7 Hz and exhibits the classical squeezing and prying motion expected of SWATH ships. The forward and aft pods are in phase with each other throughout the cycle. The forward pods also exhibit a torsional response during the cycle. Figure 11 shows the deformed geometry plot of this mode shape during the pry cycle.

2. Second Mode

The second mode occurs at a natural frequency of 5.1 Hz with the aft pods displaying a squeezing and prying motion. The forward pods exhibit a "racking" motion in which the two pods travel in the same direction. The forward pods travel to starboard during the aft pod's pry cycle and travel to port during the squeeze cycle. Once again, a twisting motion is observed on the forward pods. Figure 12 shows this mode shape during the aft pod's pry cycle.

3. Third Mode

The third mode is very similar to the second mode and occurs at a natural frequency of 5.5 Hz. The main difference between the two modes is that the racking motion of the forward pods moves to port during the pry cycle and to starboard during the squeeze cycle. Figure 13 displays this mode shape during the pry cycle.

4. Fourth Mode

The fourth mode has a natural frequency of 6.1 Hz and displays the classical longitudinal bending response of a monohull. There is no pod torsion as observed with the previous modes. Figure 14 illustrates this mode shape.

B. LINEAR STATIC ANALYSIS

A linear static analysis was conducted on the model based upon the results obtained during the normal mode analysis. Three load cases were considered using a 200 Lton side load superimposed with a 168 Lton buoyancy force and a 168 Lton gravitational force. The 200 Lton side force was divided equally between the forward and aft pods. The three load cases evaluated were:

- (1) Prying force applied to the forward and aft pods,
- (2) Squeezing force applied to forward and aft pods, and
- (3) Racking force applied to the forward and prying force applied to the aft pods.

1. Load Case One (Prying Force)

Figure 15 displays the Von Mises stress contour plot for the SLICE's external skin. The units of stress are expressed in pounds force per square foot (lb/ft^2) on the

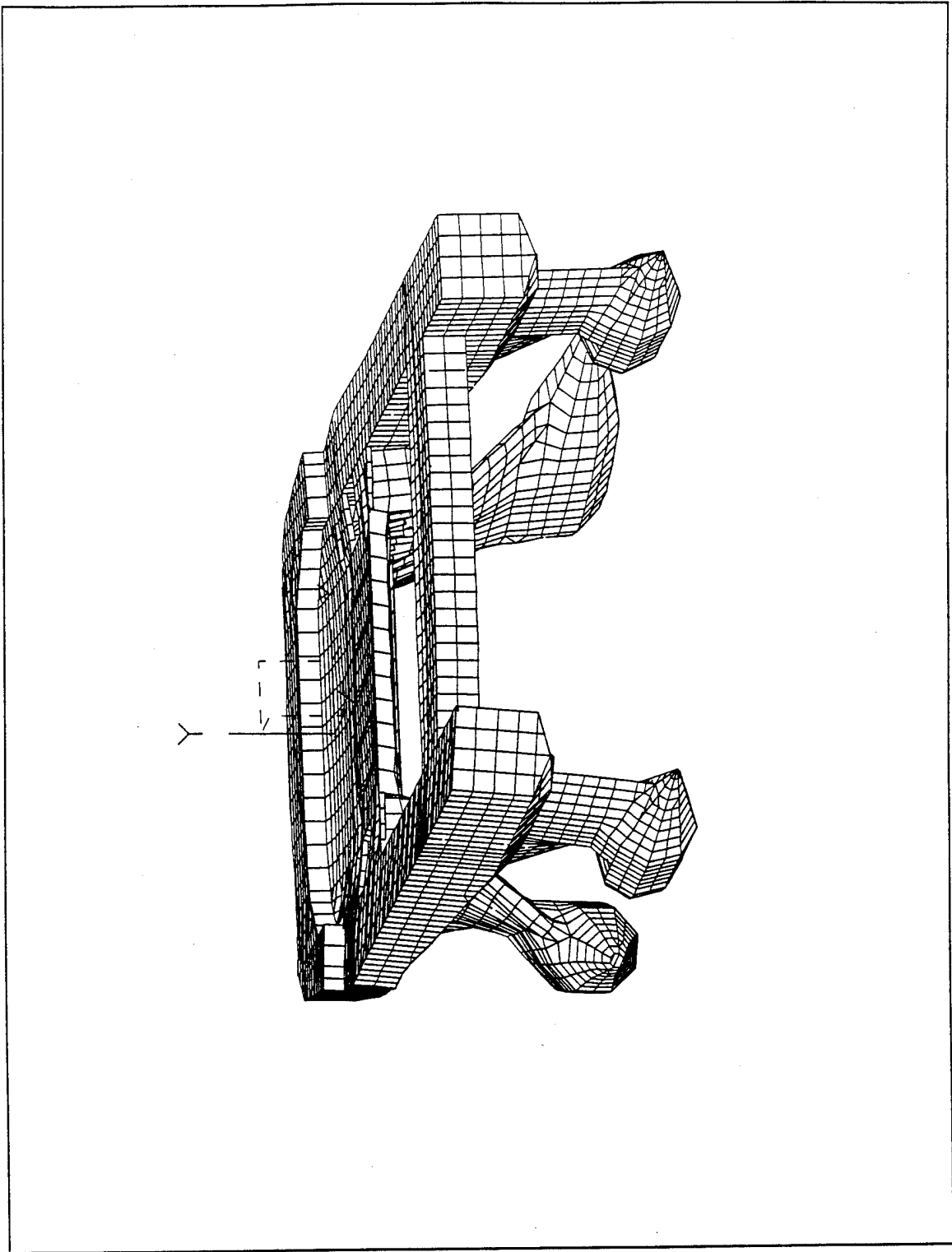

Figure 11. Deformed Geometry Plot of First Mode (4.7 Hz)

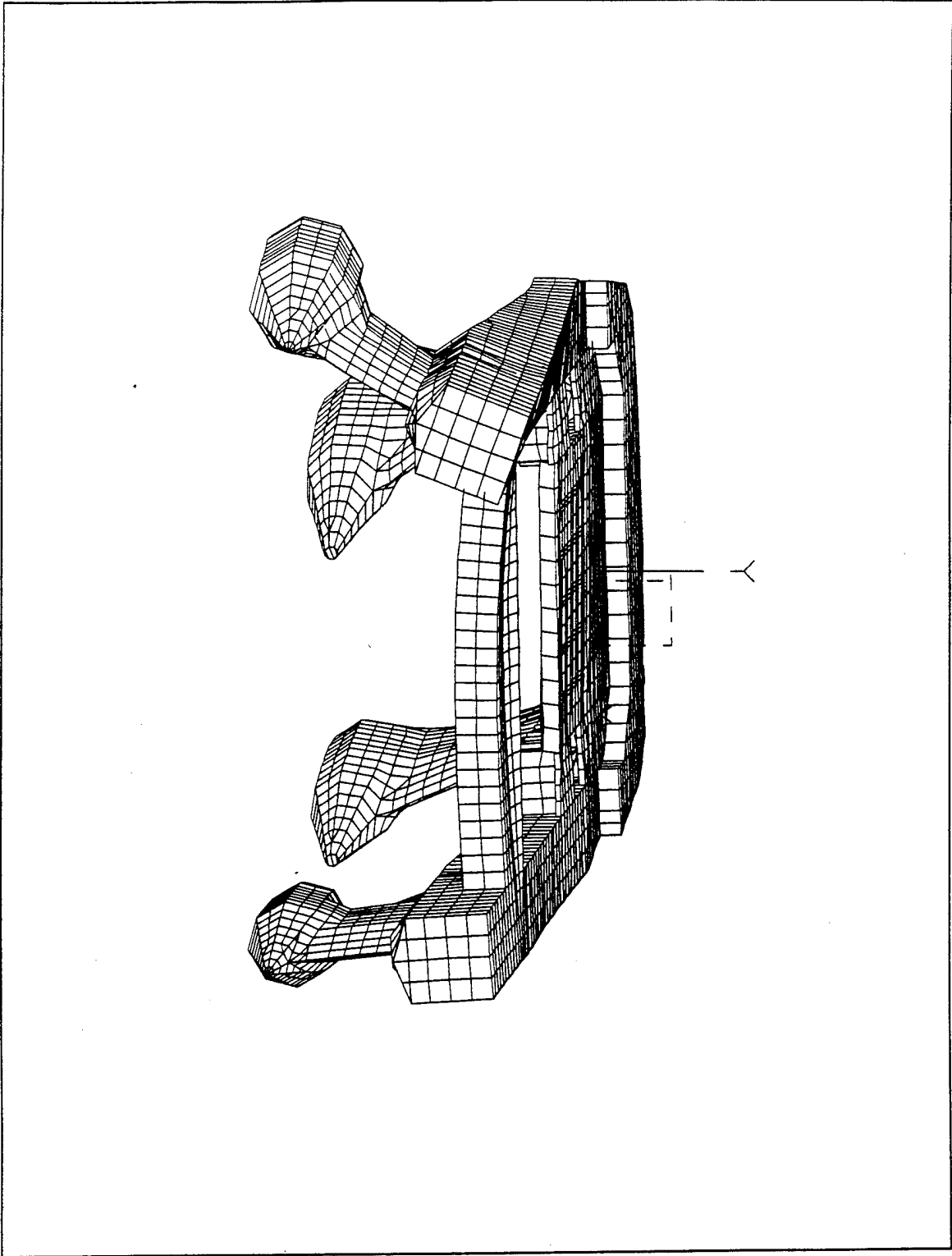

Figure 12. Deformed Geometry Plot of Second Mode (5.1 Hz)

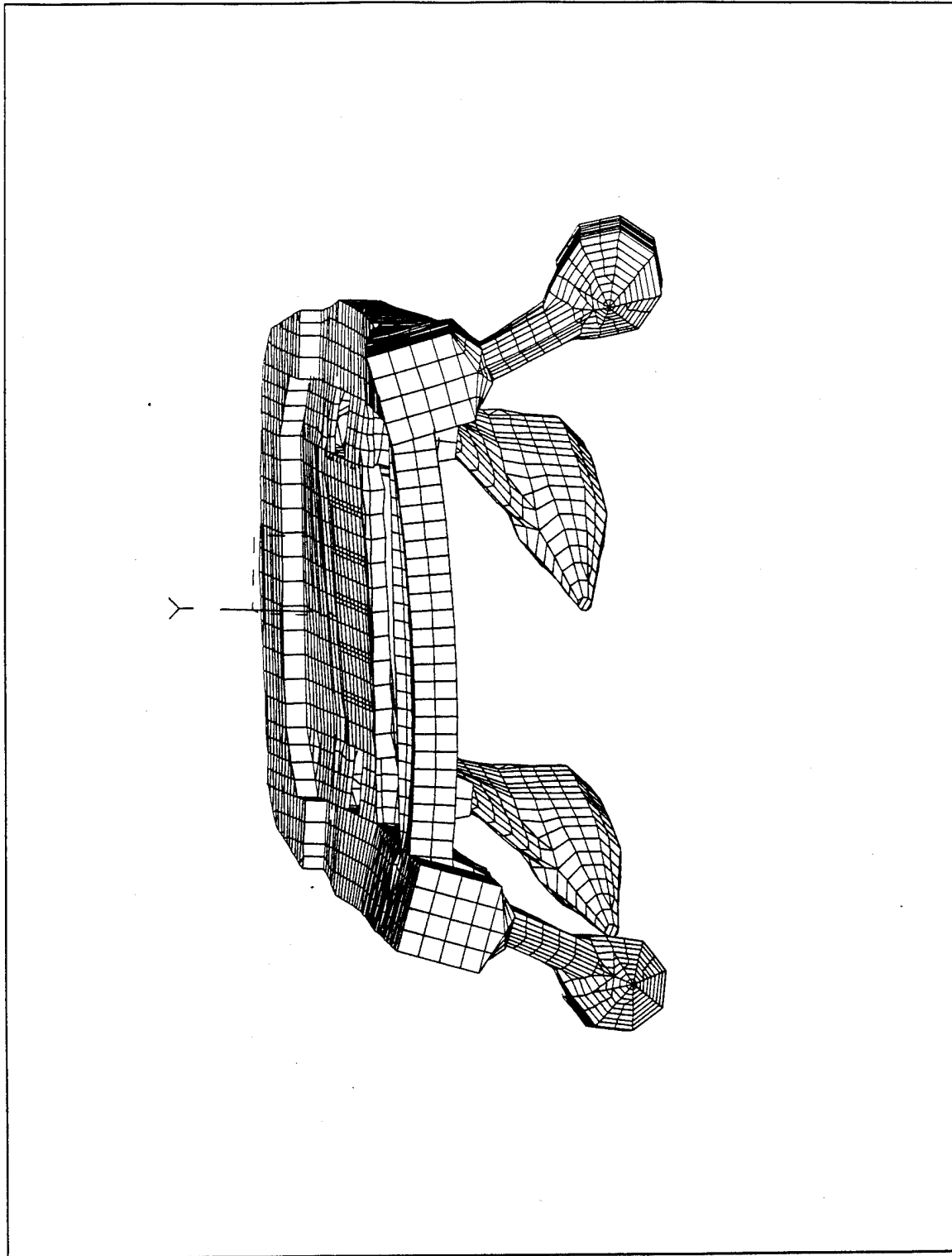

Figure 13. Deformed Geometry Plot of Third Mode (5.5 Hz)

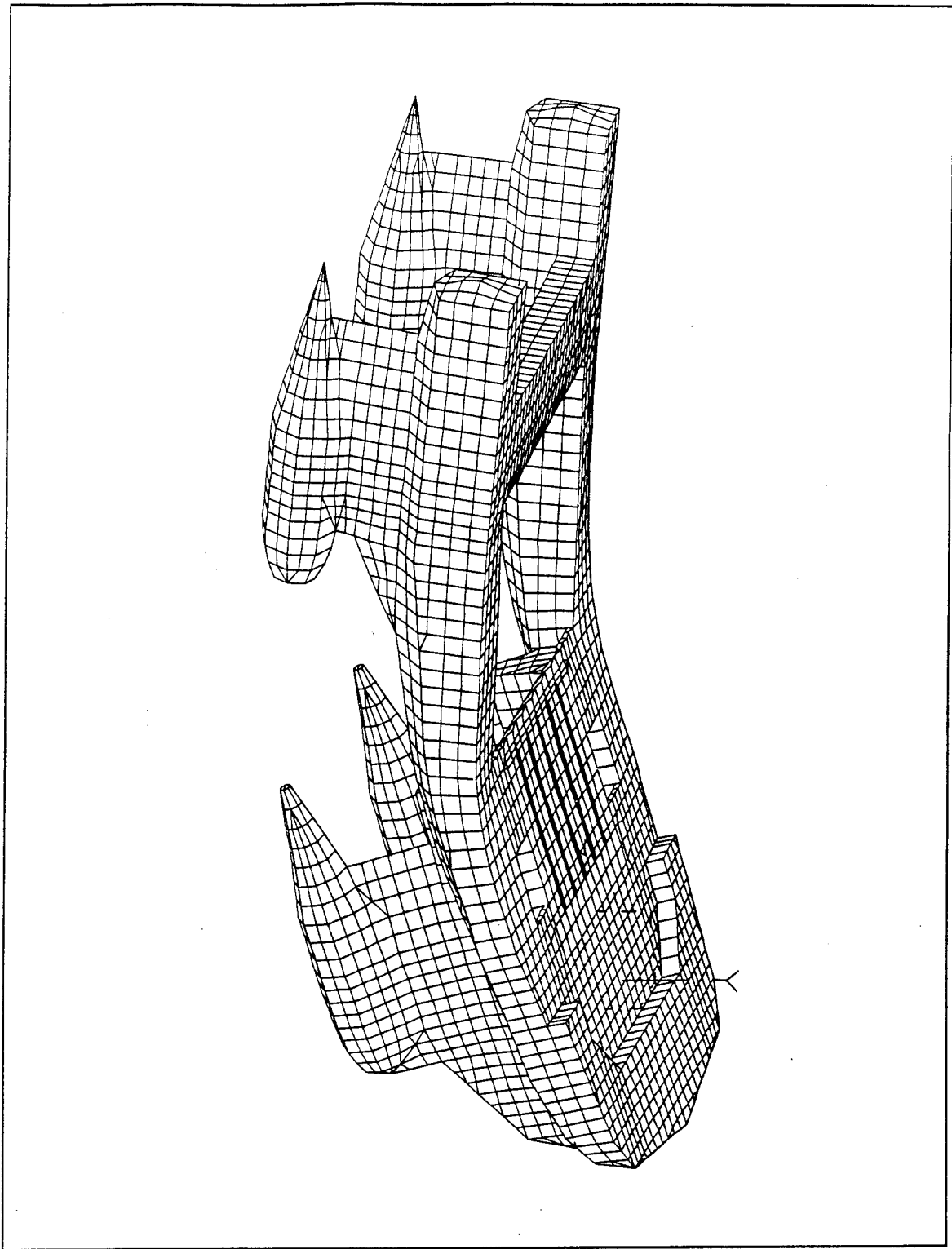

Figure 14. Deformed Geometry Plot of Fourth Mode (6.1 Hz)

color bar. Due to shear lag, the transverse bulkheads and adjacent shell plating absorb most of the shear and bending moments caused by the loads. The stress contour plot for the transverse bulkheads is shown in Figure 16. The forward and aft spars were designed to carry most of the primary load; and that is in fact what occurs. The forward and aft spar stress contour plots are presented in Figures 17 and 18, respectively. It is interesting to note that the high stress areas are predominately in the struts and not in the haunch area (as in previous SWATH designs). This can be attributed to the unique design of the spars. The curved I-beam reduces stress concentrations and is also strengthened by using a 0.50 inch web thickness in the haunch area. Because the struts only have a 0.25 inch web thickness, the stress is higher in that region. The stress in the strut region (≈ 21 ksi) comes dangerously close to the material's yield stress (24 ksi).

2. Load Case Two (Squeezing Force)

The results for the squeeze cycle are very similar to the pry cycle. The Von Mises stress contour plots are presented in Figures 19 through 22. Once again, the struts of the forward and aft spars are the limiting stress regions with a maximum stress of approximately 21 ksi.

3. Load Case Three (Racking Force Forward/Prying Force Aft)

This unique loading condition places a torsional moment along the SLICE's starboard longitudinal girder. As shown in Figures 23 and 24, the aft starboard pod and adjacent transverse bulkheads absorb most of the shear and bending moments. As observed from Figures 25 and 26, the stress in the aft spar is approximately twice the magnitude of the forward spar. The limiting stress for this loading condition is in the aft spar's strut with a maximum value of approximately 24 ksi.



Figure 15. Von Mises Stress Contour Plot of Entire Ship (Prying Force)

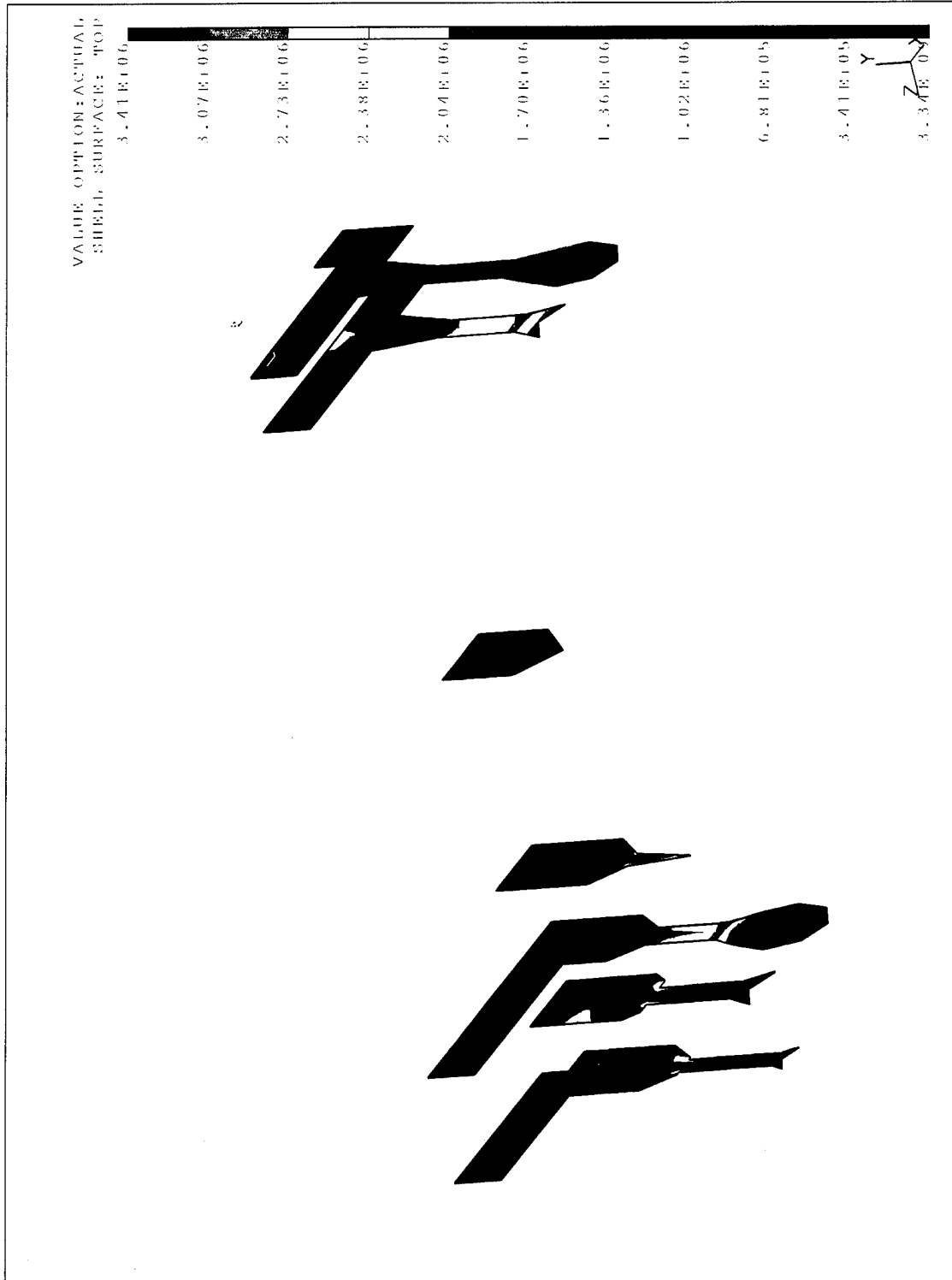

Figure 16. Von Mises Stress Contour Plot of Transverse Bulkheads (Prying Force)

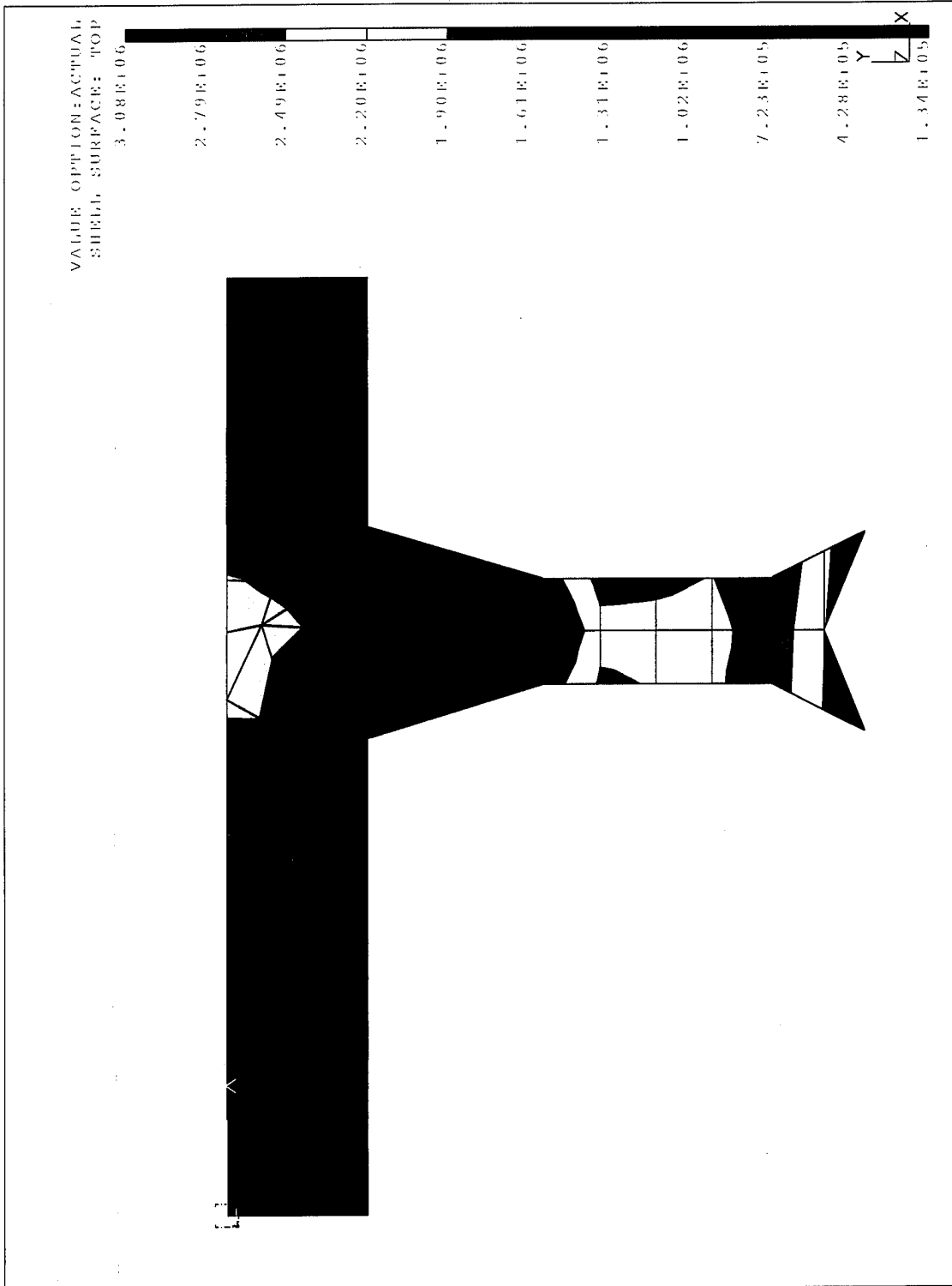

Figure 17. Von Mises Stress Contour Plot of Forward Spar (Prying Force)

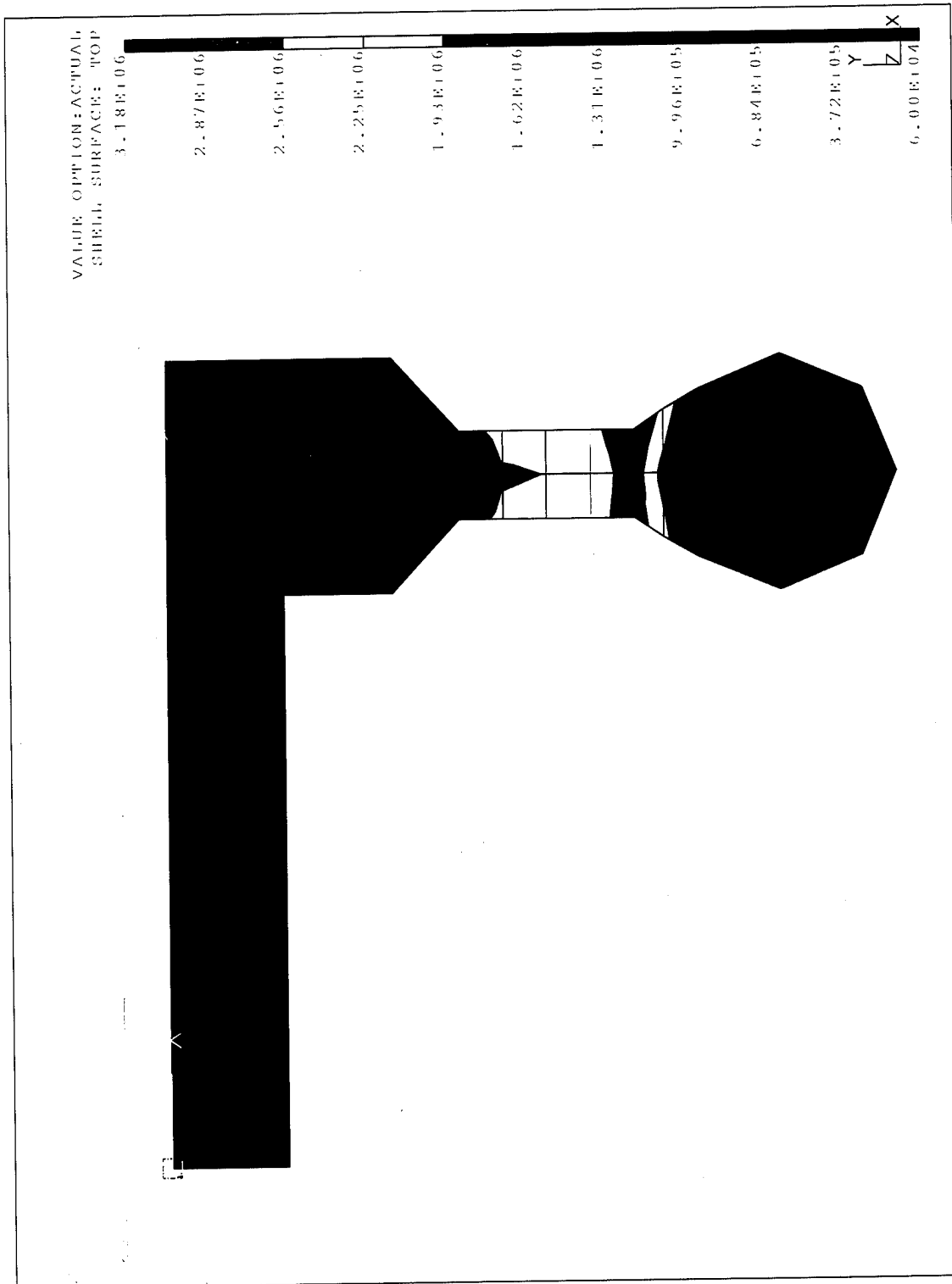

Figure 18. Von Mises Stress Contour Plot of Aft Spar (Prying Force)



Figure 19. Von Mises Stress Contour Plot of Entire Ship (Squeezing Force)



Figure 20. Von Mises Stress Contour Plot of Transverse Bulkheads (Squeezing Force)

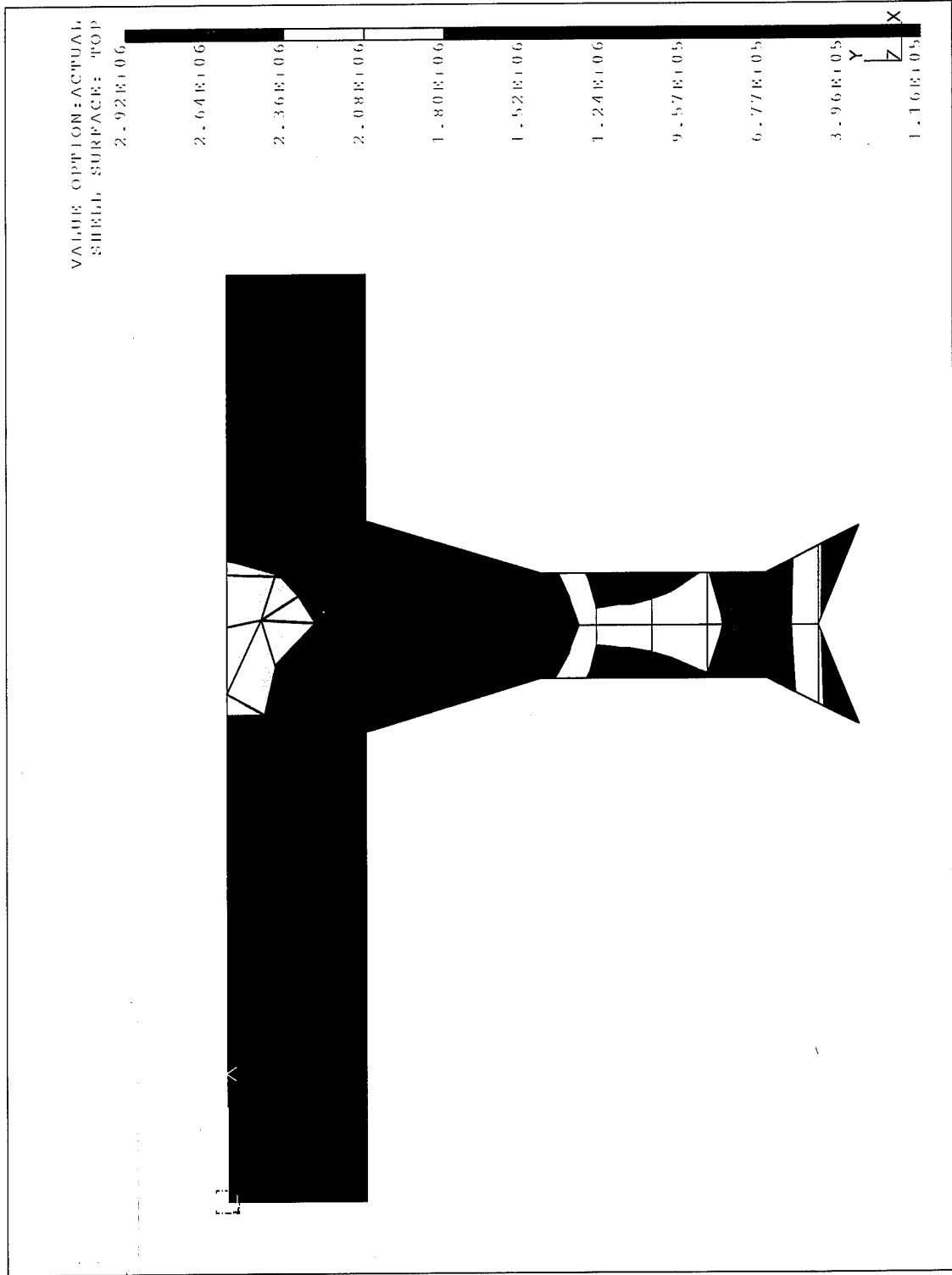

Figure 21. Von Mises Stress Contour Plot of Forward Spar (Squeezing Force)

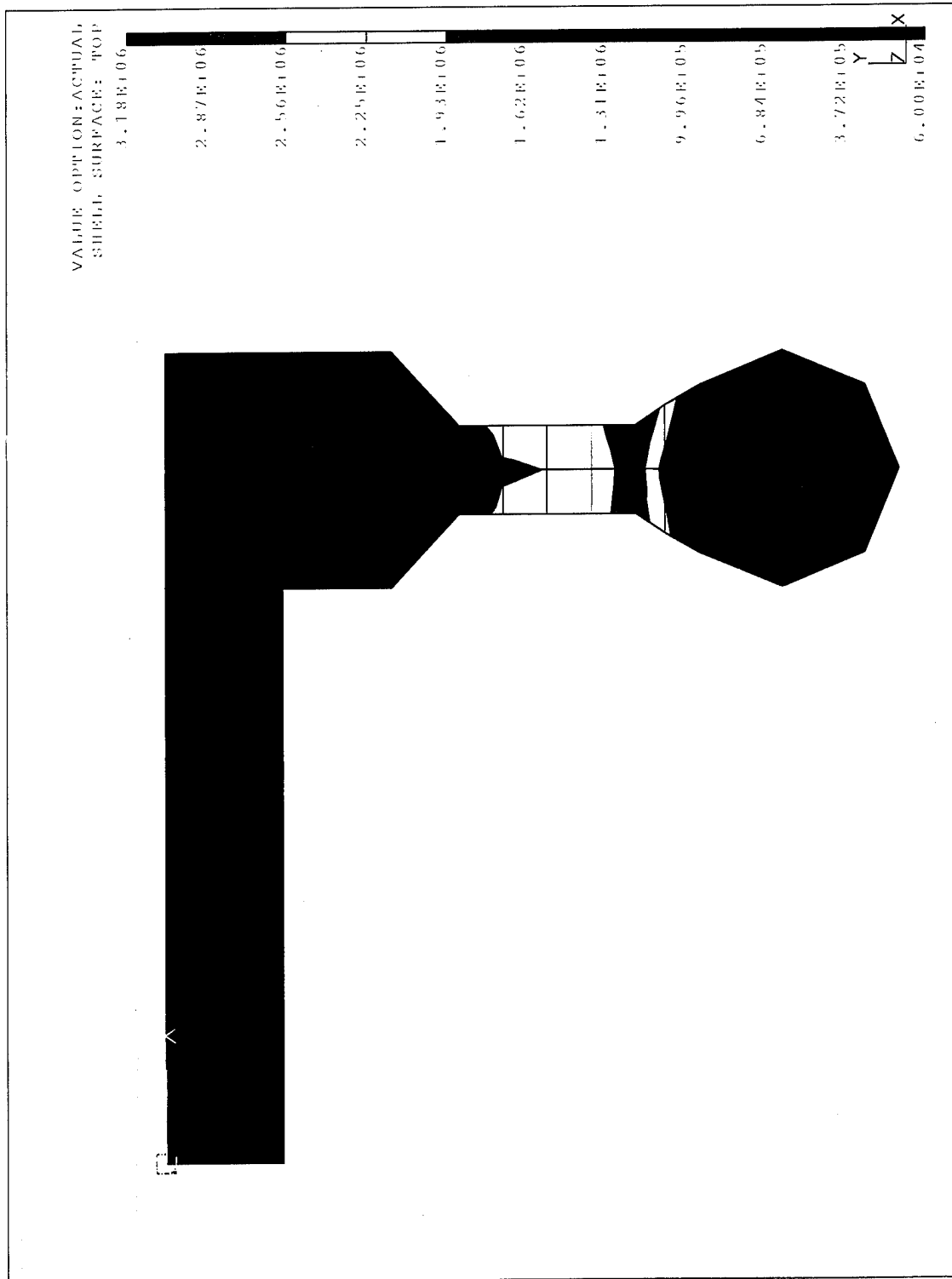

Figure 22. Von Mises Stress Contour Plot of Aft Spar (Squeezing Force)



Figure 23. Von Mises Stress Contour Plot of Entire Ship
(Racking Force Forward/Prying Force)



Figure 24. Von Mises Stress Contour Plot of Transverse Bulkheads
(Racking Force Forward/Prying Force Aft)

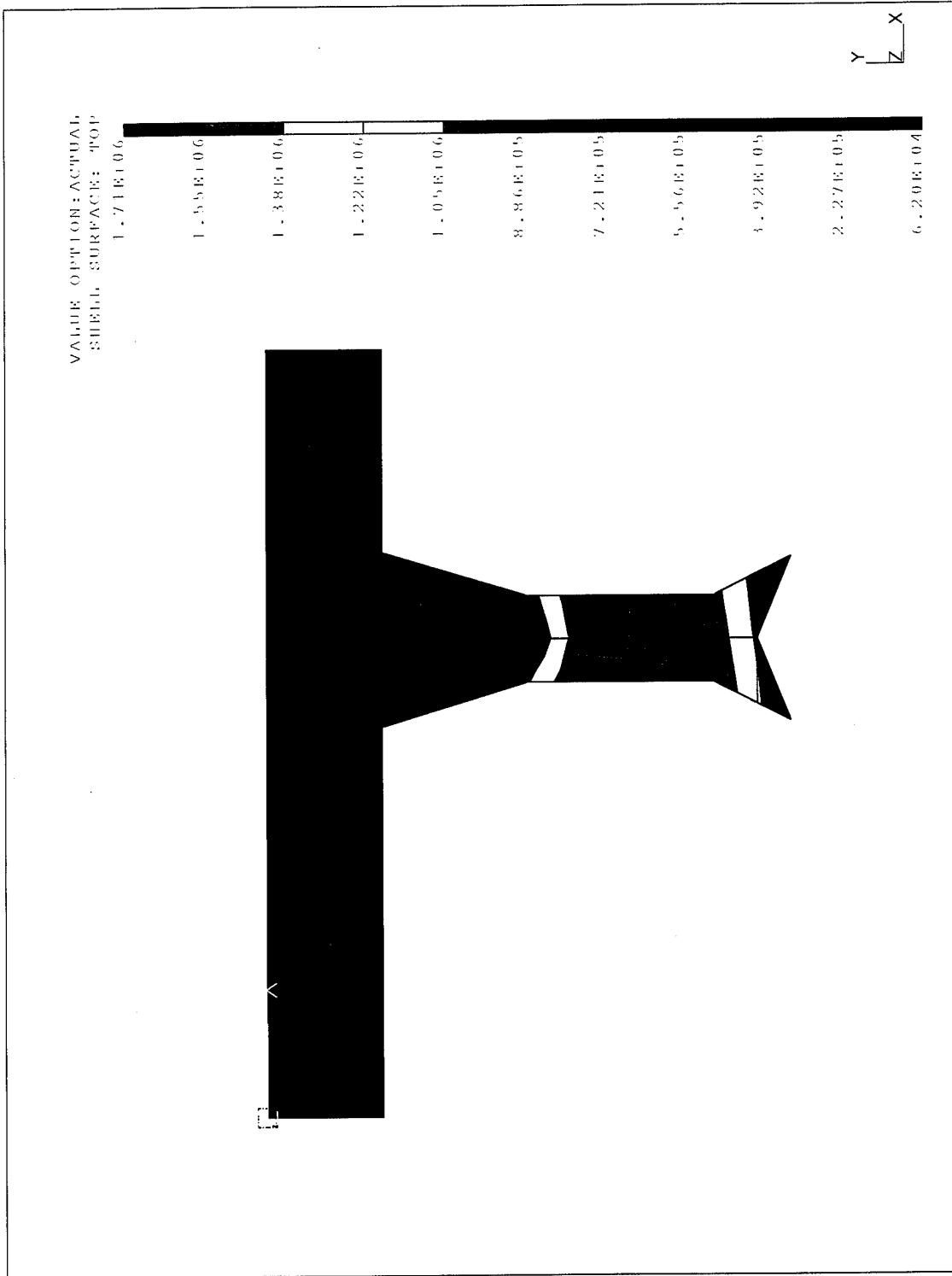

Figure 25. Von Mises Stress Contour Plot of Forward Spar
 (Racking Force Forward/Prying Force Aft)

INITIAL DISTRIBUTION LIST

	No. Copies
1. Defense Technical Information Center Cameron Station Alexandria, Virginia 22304-6145	2
2. Library, Code 52 Naval Postgraduate School Monterey, California 93943-5101	2
3. Office of the Military Attache Royal Thai Embassy 2440 Foxhall Road, N.W. Washington, D.C. 2007	2
4. Katsuaki L. Terasawa, Code SM/Tk Naval Postgraduate School Monterey, California 93943	1
5. William R. Gates, Code SM/Gt Naval Postgraduate School Monterey, California 93943	1
6. Sompodh Sripoom 41/874 Moo 4, Soi Plai-Na Ladpraow Subdist., Ladpraow Dist. Bangkok 10230, THAILAND	2