

Carderock Division, Naval Surface Warfare Center

Silver Spring, Maryland 20903-5640

CARDIVNSWC-TR-95/028

1 October 1995

Survivability, Structures and Materials Directorate (Code 60)

Electrical Characterization of Fiber-Reinforced Composites for Mast and Radome Applications

by
John M. Liu

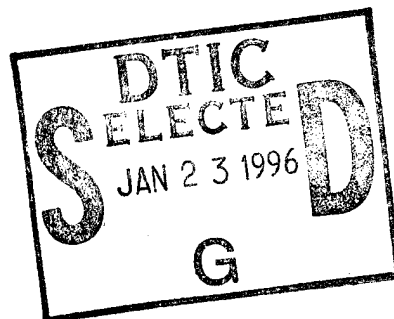

19960117 036



Approved for public release; distribution is unlimited.

Electrical Characterization of Fiber-Reinforced Composites for Mast and Radome Applications

CARDIVNSWC-TR-95/028

MAJOR CARDEROCK DIVISION TECHNICAL COMPONENTS

- CODE 011 Director of Technology
- 10 Machinery Systems/Programs and Logistics Directorate
 - 20 Ship Systems and Programs Directorate
 - 50 Hydromechanics Directorate
 - 60 Survivability, Structures and Materials Directorate
 - 70 Signatures Directorate
 - 80 Machinery Research and Development Directorate
 - 90 Machinery In-Service Engineering Directorate

CARDEROCK DIVISION, NSWC, ISSUES THREE TYPES OF REPORTS:

1. **CARDEROCKDIV reports, a formal series**, contain information of permanent technical value. They carry a consecutive numerical identification regardless of their classification or the originating directorate.
2. **Directorate reports, a semiformal series**, contain information of a preliminary, temporary, or proprietary nature or of limited interest or significance. They carry an alphanumeric identification issued by the originating directorate.
3. **Technical memoranda, an informal series**, contain technical documentation of limited use and interest. They are primarily working papers intended for internal use. They carry an identifying number which indicates their type and the numerical code of the originating directorate. Any distribution outside CARDEROCKDIV must be approved by the head of the originating directorate on a case-by-case basis.

REPORT DOCUMENTATION PAGE

Form Approved
OMB No. 0704-0188

Public reporting burden for this collection of information is estimated to average 1 hour per response, including the time for reviewing instructions, searching existing data sources, gathering and maintaining the data needed, and completing and reviewing the collection of information. Send comments regarding this burden estimate or any other aspect of this collection of information, including suggestions for reducing this burden, to Washington Headquarters services, Directorate for Information Operations and Reports, 1215 Jefferson Davis Highway, Suite 1204, Arlington, VA 22202-4302, and to the Office of Management and Budget, Paperwork Reduction Project (0704-0188), Washington, DC 20503.

1. AGENCY USE ONLY (Leave blank)	2. REPORT DATE 1 October 1995	3. REPORT TYPE AND DATES COVERED Final
----------------------------------	----------------------------------	---

4. TITLE AND SUBTITLE Electrical Characterization of Fiber-Reinforced Composites for Mast and Radome Applications	5. FUNDING NUMBERS
6. AUTHOR(S) John M. Liu	

7. PERFORMING ORGANIZATION NAME(S) AND ADDRESS(ES) Naval Surface Warfare Center, Carderock Division White Oak Laboratory Detachment, Code 684 10901 New Hampshire Ave. Silver Spring, MD 20903-5640	8. PERFORMING ORGANIZATION REPORT NUMBER
---	--

9. SPONSORING/MONITORING AGENCY NAME(S) AND ADDRESS(ES) Naval Surface Warfare Center, Dahlgren Division 17320 Dahlgren Road Dahlgren, VA 22448-5100	10. SPONSORING/MONITORING AGENCY REPORT NUMBER
--	--

11. SUPPLEMENTARY NOTES

12a. DISTRIBUTION/AVAILABILITY STATEMENT Approved for public release; distribution is unlimited.	12b. DISTRIBUTION CODE
---	------------------------

13. ABSTRACT (Maximum 200 words)
<p>This work was undertaken to assess the accuracy and precision achievable by using an open-ended coaxial "probe" in conjunction with an automated network analyzer for the characterization of the microwave dielectric properties of composites for antenna radomes. Reported herein are the influence of material thickness, surface roughness, and instrument calibration on this technique which requires only one-sided access to the material. The unknown dielectric properties of several glass fiber reinforced polymers were evaluated after the measurement system demonstrated satisfactory results on well known materials like Teflon and fused quartz. Limited low frequency testing (40 MHz) was also done on selected composites with electrodes attached for capacitance and loss measurement, yielding results in substantial agreement with those in the microwave regime. It is concluded that the microwave "probe" technique should be applied only for materials of substantial thickness and smooth surface conditions. Because of the need for rigid fixturing, this technique is not recommended for routine applications in the field.</p>

14. SUBJECT TERMS radome dielectric constant dielectric probe	15. NUMBER OF PAGES 46
	16. PRICE CODE

17. SECURITY CLASSIFICATION OF REPORT UNCLASSIFIED	18. SECURITY CLASSIFICATION OF THIS PAGE UNCLASSIFIED	19. SECURITY CLASSIFICATION OF ABSTRACT UNCLASSIFIED	20. LIMITATION OF ABSTRACT SAR
---	--	---	-----------------------------------

FOREWORD

This effort was conducted as a seed and venture project sponsored by the Naval Surface Warfare Center (NSWC), Dahlgren Division.

The author wishes to thank Mr. Gilbert Lee, NSWC, Carderock Division who promoted the interest in the application of the dielectric probe for materials characterization; Dr. John H. Wasilik of Wasilik Associates for making most of the measurements; and to Mr. Douglas Loup, NSWC, Carderock Division and Dr. John Grosvenor, National Institute of Standards and Technology (NIST), Boulder, Colorado for supplying the composite and standard materials; and Dr. Gerry Blessing, NIST, Gaithersburg, Maryland for assistance in measuring the surface roughness of the composite samples.

Accession For	
NTIS CRA&I	<input checked="" type="checkbox"/>
DTIC TAB	<input type="checkbox"/>
Unannounced	<input type="checkbox"/>
Justification	
By	
Distribution /	
Availability Codes	
Dist	Avail and/or Special
A-1	

Approved by:

Carl E. Mueller

CARL E. MUELLER, Head
Weapons Materials Department

ABSTRACT

This work was undertaken to assess the accuracy and precision achievable by using an open-ended coaxial "probe" in conjunction with an automated network analyzer for the characterization of the microwave dielectric properties of composites for antenna radomes. Reported herein are the influence of material thickness, surface roughness, and instrument calibration on this technique which requires only one-sided access to the material. The unknown dielectric properties of several glass fiber reinforced polymers were evaluated after the measurement system demonstrated satisfactory results on well known materials like Teflon and fused quartz. Limited low frequency testing (40 MHz) was also done on selected composites with electrodes attached for capacitance and loss measurement, yielding results in substantial agreement with those in the microwave regime. It is concluded that the microwave "probe" technique should be applied only for materials of substantial thickness and smooth surface conditions. Because of the need for rigid fixturing, this technique is not recommended for routine applications in the field.

CONTENTS

	<u>Page</u>
INTRODUCTION	1
PROCEDURES	1
GHZ DIELECTRIC PROBE MEASUREMENT SYSTEM.....	1
Dielectric Probe.....	2
Specimen Holder and Fixtures	2
Specimen Preparation and Surface Roughness	2
System Calibration via HP 85070A Software	2
LOW FREQUENCY (40 MHZ) MEASUREMENT SYSTEM	3
RESULTS	4
DIELECTRIC PROBE (0.2 - 20 GHZ)	4
General Survey of Low Loss Materials.....	4
Effects of Material Surface Roughness	5
Effects of Material Thickness.....	5
Effects of Calibration, Cable Arrangements, and Support Fixtures.....	6
LOW FREQUENCY (40MHZ) IMPEDANCE ANALYSIS	6
CONCLUSIONS	6
RECOMMENDATIONS AND FUTURE PLANS	7
REFERENCES	36

ILLUSTRATIONS

<u>Figure</u>		<u>Page</u>
1	Schematic of Microwave Measurement System	8
2	Sketch of the Hewlett Packard Dielectric Probe	9
3	Material Specimen and Probe Holding Fixture	10
4	Polar Display without Material Coupled to Probe	11
5	Polar Display with the Probe Shorted	11
6	Polar Display with the Probe Submerged in Water	12
7	Low Frequency (40 MHz) Impedance Analysis of Composite Specimens	13
8	Dielectric Constant of Fused Quartz from 3 to 10 Ghz.....	14
9	Room Temperature Dielectric Constant of water from 0.2 through 20 Ghz.....	15
10	Dielectric Constant of Teflon from 0.2 through 20 Ghz	16
11	Dielectric Constant of Lucite from 0.2 through 20 Ghz.....	17
12	Dielectric Constant of Polished, Two Layers Thick Composite Spectra/VE8084 from 0.2 through 20 Ghz.....	18
13	Dielectric Constant of Polished, Two Layers Thick Composite WR/8510-9 from 0.2 through 20 Ghz	19
14	Dielectric Constant of Polished, Two Layers Thick Composite WR/VE510A from 0.2 through 20 Ghz	20
15	Dielectric Constant of Polished, Two Layers Thick Composite BIA/EG/VE510A from 0.2 through 20 Ghz.....	21
16	Dielectric Constant of Polished, Two Layers Thick Composite WR/Spectra 50P/VE510A from 0.2 through 20 Ghz.....	22
17	Apparent Dielectric Constant at Four Locations 0.020 inch Apart on Unpolished Composite WR/VE510A	23
18	Surface Profilometry on Composite WR/VE510A	24
19	Apparent Dielectric Constant at Four Locations of Unpolished and Polished Composite 7781/510A	25
20	Surface Profilometry on Composite 7781/510A	26
21	Apparent Dielectric Constant for a Single Layer, Polished Composite 7781/510A ...	27
22	Apparent Dielectric Constant for a Two-Layer Stack, Polished Composite 7781/510A.....	28
23	Apparent Dielectric Constant for a Three-Layer Stack, Polished Composite 7781/510A.....	29
24	Apparent Dielectric Constant of a Single-Layer, Polished Composite WR/8510-9....	30
25	Apparent Dielectric Constant of a Stack of Two Unpolished Layers of WR/VE510A	31

ILLUSTRATIONS (continued)

<u>Figure</u>		<u>Page</u>
26	Apparent Dielectric Constant of a Stack of Three Unpolished Layers of WR/VE510A.....	32
27	Apparent Dielectric Constant of Composite 7781/510A Using Two Different Calibrations	33
28	Dielectric Constant Measured When the Probe Was Not Coupled to Material.....	34
29	Capacitance and Loss Versus Frequency.....	35

INTRODUCTION

There are a number of different approaches to measure the dielectric constant (the real part of the relative permittivity) and the loss tangent (the ratio of the imaginary to the real part of the relative permittivity) of a solid material. Some of these require cutting a material into pieces of very precise dimensions for measurements in a waveguide or a resonator, or attaching electrical leads to the material surfaces. Techniques based on a momentary coupling of the material to an open-ended waveguide or transmission line have two significant advantages; they require minimum sample preparation and are nondestructive. Such a "dielectric probe" approach has been analyzed and applied by a number of investigators with some degree of success (references 1 through 4).

In this work we examined the potential for nondestructive characterization of the dielectric properties of some low loss materials, with particular emphasis on the effect of the following variables on the measurement results:

- (a) calibration procedure, cabling, equipment lay out;
- (b) specimen fixturing and conditions;
- (c) specimen surface roughness;
- (d) specimen thickness; and
- (e) stacking layers to increase specimen thickness.

The dielectric probe used in this work is available from Hewlett Packard Corporation (references 5 and 6). The following section describes how to operate the probe, the calibration procedure, specimen preparation, and mounting fixtures. The accuracy and repeatability of results obtained on known materials is shown first, since results on unknown composites are influenced by the conditions listed above. Following some comments on this dielectric probe approach, results are presented which were obtained by a low frequency (40 MHz) impedance measurement technique on some of the same materials tested at GHz frequencies with the dielectric probe.

PROCEDURES

GHZ DIELECTRIC PROBE MEASUREMENT SYSTEM

A schematic diagram of the GHz measurement system based on the Hewlett Packard dielectric probe is shown in Fig. 1. The primary instrument, in addition to the probe, is the Model 8722C Vector Network Analyzer. Software specifically designed for converting the raw probe response to the dielectric constant and loss tangent is provided by Hewlett Packard. A HP 9836 computer equipped with a hard disc drive uses this software to control the Network Analyzer, performs the measurements, and outputs plots or data files for later analysis.

Dielectric Probe

The HP 85070A Dielectric Probe is a truncated 50-Ohm coaxial transmission line (3.5-mm outer diameter), fitted with an additional flange to facilitate its positioning normal to the solid surface being measured, and to provide additional shielding. See Figure 2.

Specimen Holder and Fixtures

A high quality, flexible, microwave cable spanning the desired frequency range is used to connect one of the output ports in the network analyzer to the dielectric probe. A number of approaches were tried to hold the probe against the specimen.

Initially, we used a lab stand and clamp to hold the dielectric probe and a precision lab jack to move the sample or water load up to the probe. A layer of low density polyethylene was placed between the lab jack and the sample to more evenly distribute the stress with which the sample was pressed against the probe. To further improve the rigidity of the sample holding fixtures, a device shown in Figure 3 was used in the later stages of this study to assure that specimen placement was reproducible. This also prevented any movement of the cable prior to any measurement, which could have compromised the integrity of the calibration. A one inch thick polyethylene foam was used between the lab jack and the sample to distribute the stress with which the sample was pressed against the dielectric probe.

The trace on the polar display in the Network Analyzer was closely observed as this stress was increased by raising the specimen against the probe via the lab jack, stopping when increased stress no longer changed the display. Considerable force was often required to accomplish this.

Specimen Preparation and Surface Roughness Measurement

The sample surface contacted by the probe was rendered reasonably smooth and flat. This was satisfactorily accomplished by a water grind first with 400 grit followed by 600 grit paper on a plate glass. Some specimens were purposely unpolished in order to allow an evaluation of the effect of surface roughness on the measurements. A quantitative measure of this roughness was obtained by using a Taylor-Hobson Profilometer (model Surtronic 3). This is essentially a traveling stylus which provides an electronic signal, representing the topography of the surface, and a number which is the height of surface features averaged over the distance traversed. This distance was fixed at 2.5 mm. The instrument was calibrated with a standard having an average roughness of 6 microns. The electronic recorder output signal provided a measure of the large undulations (as a consequence of the weaving patterns of large fiber bundles in the composites) as well as the smaller roughness features between these.

System Calibration via HP 85070A Software

After executing the startup command for the HP85070A software, one would select the program's calibration procedure, if no satisfactory calibration exists. The software prompts the user through the three calibration steps; open, short, and water load. The software implements a polar display on the Network Analyzer. Frequent reference to this display and a recognition of its characteristics at each stage of the calibration and measurement is quite important. The software prompts the operator to perform the calibration as follows:

The first setup is to make measurement when the probe is "open". Here, the probe is allowed to radiate into free space, such that there is no significant signal reflected back to the probe. Experimentally one can move a reflecting surface near the probe while looking for a change in polar display on the Network Analyzer, and then make sure that any reflecting surface is positioned several times this distance away from the probe. The pattern one should see is a polar display, as shown in Figure 4.

In the next step, the software requests shorting of the dielectric probe. For this purpose HP supplies a gold plated disc along with a spring clip which presses the disc against the probe surface. The pattern one should observe is that of a small "hair ball" at almost maximum radius at 180° (see Figure 5). One may find that "ringing in" of the disc within the spring clip, as it is being held against the probe, makes a better short. Again experimentation and experience are important in determining what constitutes a "good" short. Cleanliness and flatness of the shorting surface may be important. When surface scratches are visible, turning over the disc before a measurement is made should also improve this result. After prolonged use it may be necessary to polish the shorting disc.

The third step in the calibration process is to place the probe in pure water. To date, we have used distilled water supplied by the General Services Administration for storage battery use. Deionized, outgassed water or pure, hermetically sealed capsules from bio-tech suppliers may also be used. Since the dielectric constant of water is temperature dependent, this temperature should be recorded to the accuracy of 0.1° C, and then supplied to the Calibration software when prompted. When one immerses the probe in the calibrating water, it may be important to agitate the water next to the probe to free this interface from any entrapped bubbles. A sweep of this interface with an inert wire or plastic wand should suffice. A smooth arc of approximately 180 degrees should be observed on the polar display, as shown in Figure 6. More details of the calibration procedure can be found in reference 7.

The software provides for the storage and labeling of each calibration, which one does after a seemingly satisfactory calibration has been performed. More will be said about calibration selection when we discuss the actual measurements.

LOW FREQUENCY (40 MHZ) MEASUREMENT SYSTEM

A Hewlett Packard Model 4194A Impedance Analyzer was used in a system shown schematically in Figure 7 (a). Here, electrodes had to be affixed onto the specimen for measurement. For electrodes we used 0.75 inch diameter, adhesive-backed aluminum foil. Since the foil conformed to the somewhat uneven surface of the sample, grinding was deemed unnecessary. A specimen with electrodes affixed is shown in Figure 7 (b). A "glue alone" capacitor was formed of electrodes of the same diameter, as shown in Figure 7 (c).

For analysis, we modeled the specimen material and the glue as capacitors in series. If we represent the measured capacitance by C , the material capacitance by C_1 , and the glue capacitance by C_2 , then

$$\frac{1}{C} = \frac{1}{C_1} + \frac{1}{C_2} .$$

Having measured C and C_2 independently, we calculated the material capacitance C_1 . The dielectric constant ϵ of the material is then given by,

$$C_1 = \epsilon \left(\frac{S}{d} \right),$$

where S is the area of the electrode and d the material thickness.

RESULTS

DIELECTRIC PROBE (0.2 - 20 GHZ)

The dielectric constant of polymeric materials measured with the dielectric probe in the frequency range of 0.2 to 20 GHz are shown in this section to illustrate the effects of various material and measurement conditions. Data for several known materials of sufficient thickness and surface smoothness are used to check the accuracy of this approach under favorable conditions. Figure 8 shows the dielectric constant of fused quartz versus frequency. In this and other figures, the frequency is plotted logarithmically in the horizontal axis, and either the real part of the dielectric constant or the loss tangent is plotted on the vertical axis. Noisy signals are sometimes present below 1 GHz and above 10 GHz. Some of these could be due to reflections from specimen boundaries, abrupt impedance changes across cable connectors and adapters. As the dielectric constant of the material increased, these fluctuations appeared greatly diminished, as shown in Figure 9 for results in water. Dielectric constants versus frequency for Teflon and Lucite are shown in Figures 10 and 11. The averaged dielectric constants are tabulated in the table below, together with values obtained from known sources. It is seen that under these favorable conditions of thick specimen and smooth material surfaces, an accuracy better than 10 percent is obtained.

Material	Measured Values <small>see Note</small>	Literature values
Fuzed quartz	3.8 to 4.0	3.83 (Reference 8)
Teflon	2.1 to 2.3	2.07 (References 9, 10 and 11)
Lucite	2.85 to 3.05	2.60 (References 9, 10 and 11)

Note: Measured in this work in the frequency range 1 to 12 GHz over a period of 12 months using independent calibrations.

General Survey of Low Loss Materials

Several glass fiber reinforced polymer composites were provided by Mr. Douglas Loup at the Naval Surface Warfare Center Carderock Division, Annapolis Detachment. They are designated as Spectra/VE8084, WR/8510-9, WR/VE510A, BIA/EG/VE510A, and WR/Spectra 50P/VE510A and are shown in Figures 12 through 16. These materials have a dielectric constant less than 5, and a loss tangent less than 0.05, over the entire frequency band investigated. This is appropriate for radome materials. Such small loss tangents are

beyond the specified accuracies of the dielectric probe by the manufacturer. These Figures show the result obtained when two layers of polished material were stacked together during measurement.

Effects of Material Surface Roughness

Data obtained when the probe was placed on some unpolished surfaces are shown in Figures 17 and 19. Figure 17 shows data obtained on material WR/VE510A at 4 different locations approximately 0.020 inch apart. Not only was the averaged apparent dielectric constant significantly lower than values obtained on a polished surface (see Figure 14), but there were significant variations, depending on whether the probe was placed on a peak or a valley in the surface topography. The surface profilometry of this specimen is shown in Figure 18. The polished surface had a roughness of approximately 1 micron. There were large undulations on the unpolished surface. Riding on these were smaller ripples. Using the signals associated with the 6 micron standard, we estimated that these large undulations and the small ripples had a peak-to-peak amplitude of 90 and 25 microns, respectively. Surface roughness effects on material designated 7781/510A are exhibited in Figure 19. The amplitudes of the large undulations and the smaller roughness features, as shown in Figure 20, were 45 and 20 microns, respectively. It is seen that even though the roughness here was somewhat less than what existed in specimen WR/VE510A, the apparent dielectric constants were significantly less than those observed in the polished material in both instances. At present, it is not clear whether the large surface undulations or the fine ripples were the main sources of such errors.

The low value of the apparent dielectric constant was most likely due to the presence of air between a rough specimen surface and the probe surface. Since air has a dielectric constant of unity, this air/solid composite should have an effective constant less than the solid without air entrapment.

Effects of Material Thickness

The electromagnetic field generated by the dielectric probe has a certain spatial distribution. If both the dielectric constant and the loss tangent are low (so that the reflection coefficient is low), more of the electromagnetic field may penetrate into the material. If the material is thin, some of this field may emerge through the back surface of the material, which produces an apparent dielectric constant less than it would be if no field is allowed to emerge from the material as a result of larger material thickness. Thickness requirements would not be as stringent if the dielectric constant is high. In this case, reflection at the input air/material boundary is high, and the field inside is confined to a shallow layer underneath the probe, as dictated by Snell's law. Since the composites studied in this work had relatively low dielectric constants, the effects of material thickness was studied. Since the composites available were relatively thin (typically 0.125 inch), they had to be stacked up to simulate a thicker piece. Figures 21 through 23 show these thickness effects in material 7781/510A. Even though we occasionally observed increases in the apparent dielectric constant in some of these "thick pieces", at present they were not large enough or consistent enough to be definitive. Essentially, the variations observed from one measurement to the next on the same piece of material were as large as those observed when the polished pieces were stacked up, as is

evident when the results in Figures 19 through 23 are compared with one another. Thickness effects in another material, designated WR/8510-9, are shown in Figures 24 and 13.

It is noted that, when stacking up materials to simulate the response of a thick piece, the surfaces of the materials should be smooth. Otherwise, air pockets between the stacked layers would again produce an apparent dielectric constant lower than it should be, as shown in Figures 25 and 26 when unpolished pieces of material WR/VE510 were stacked together.

Effects of Calibration, Cable Arrangement, and Specimen Support Fixtures

We have noticed some effect on our measurements as a result of non-uniform clamping of the probe against the specimen. It is expected that if the probe is placed unevenly on the surface, it will lead to errors. Any change in the physical arrangement of cables and fixtures between calibration with water and measurement of the unknown material also introduces errors. We noticed occasionally that two different calibrations, both apparently correctly made, produced different material responses, as shown in Figure 27 in composites designated 7781/510A. In the later part of the experiments, we checked the response of distilled water after a calibration was completed (also against distilled water). If these did not agree substantially, the calibration, cabling, or loose connections were suspect. "Refreshing" of a calibration in the course of a series of measurements was also helpful. We also checked the response of the probe in the absence of the material, as shown in Figure 28. Presence of significant noise or value not too close to unity in this "air" response also signified electronic or mechanical problems.

LOW FREQUENCY (40 MHZ) IMPEDANCE ANALYSIS

The capacitance and loss versus frequency for a capacitor formed from the 7781/510A material using adhesive-backed aluminum foil electrodes is shown in Figure 29 (a). The capacitance and loss for the "glue alone" capacitor is given in Figure 29 (b). Using the capacitances at 10 MHz and the known material thickness, we calculate the dielectric constant to be 5.05 using the expressions shown previously in the procedure section. This value is consistent with the values (typically 4.7 to 5.0) obtained in the GHz frequency range using the dielectric probe shown previously in the same composite.

CONCLUSIONS

Our experimental results show some limitations of the Hewlett Packard dielectric probe for nondestructive characterization of fiber reinforced plastics. Due to the open-ended transmission line construction of the active surface of the probe, its accuracy is good only for fairly smooth surfaces. It should not be used as a "hand-held" probe for applications in the field, because of the difficulty in maintaining a reproducible interaction between the electromagnetic field and the material. The specimen and the probe must be carefully aligned to provide uniform contact, and the material has to have adequate thickness and without air gaps. When these conditions are met, an absolute accuracy of better than $\pm 10\%$ are attainable. The repeatability in the frequency range below 1 GHz and above 10 GHz was

worse than this number. The loss of accuracy at low frequencies is pointed out by the Hewlett Packard literature. However, the "ringing" type signal observed above 10 GHz is bothersome, and its origin is not known. It may be conjectured that the somewhat repeatable oscillation of the response at high frequencies above 12 GHz may be related to reflection and interference of the electromagnetic field from either the specimen boundaries or from impedance mismatches in the measurement system, for example, connectors. Additional work would be required to verify these hypotheses.

Part of the problem in applying this probe in composites is the inherent inhomogeneous nature of these materials. Because of the small size of the active area of the probe, it is not surprising that its response is sensitive to the positioning on the composite. Great care should be exercised when measuring materials with low dielectric constants to avoid the artifacts produced by air pockets.

RECOMMENDATIONS AND FUTURE PLANS

The nondestructive characterization of composites for radome applications poses significant challenge when high accuracy and precision are required. The relatively low cost approach based on the dielectric probe is limited by the requirement of specimen clamping, surface smoothness, thickness effects, and other mechanical alignment issues.

A truly non-contact, nondestructive technique for dielectric characterization can be based on a free-space, quasi-optics set up (references 12 through 16). Either single-sided reflection, or two-sided transmission approach has been reported in the literature. It is not known to what extent alignment and fixturing would be sources of error. Free space, collimated beam techniques would allow a larger portion of the specimen to be sampled, thereby giving an average response over the size of the beam more representative of that emerging from the antenna enclosed by the radome. These techniques can be further developed for the detection of macroscopic defects in dielectric materials (reference 17). We intend to explore some aspects of these approaches in the future.

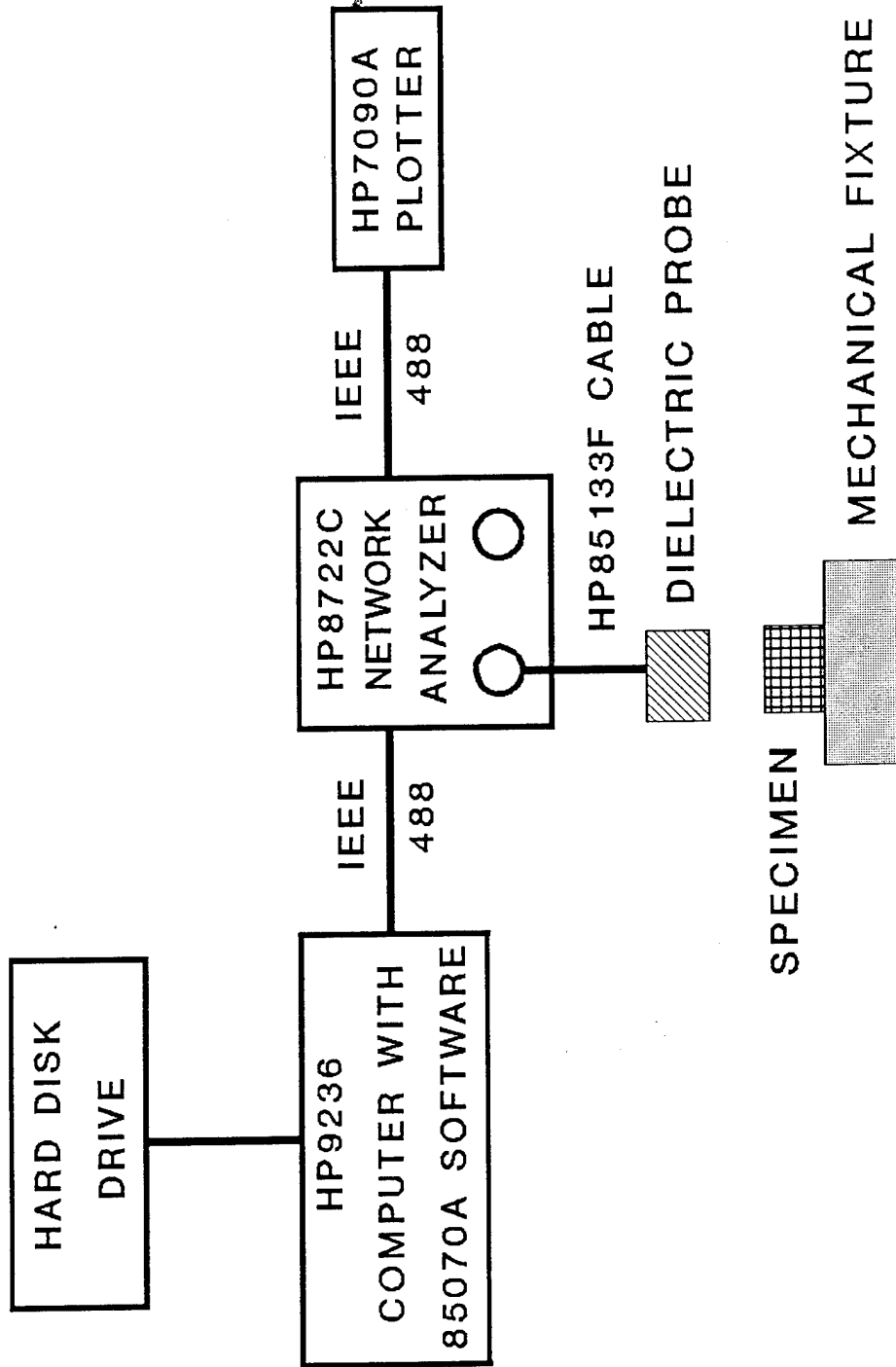

Figure 1. Schematic of Microwave Measurement System.

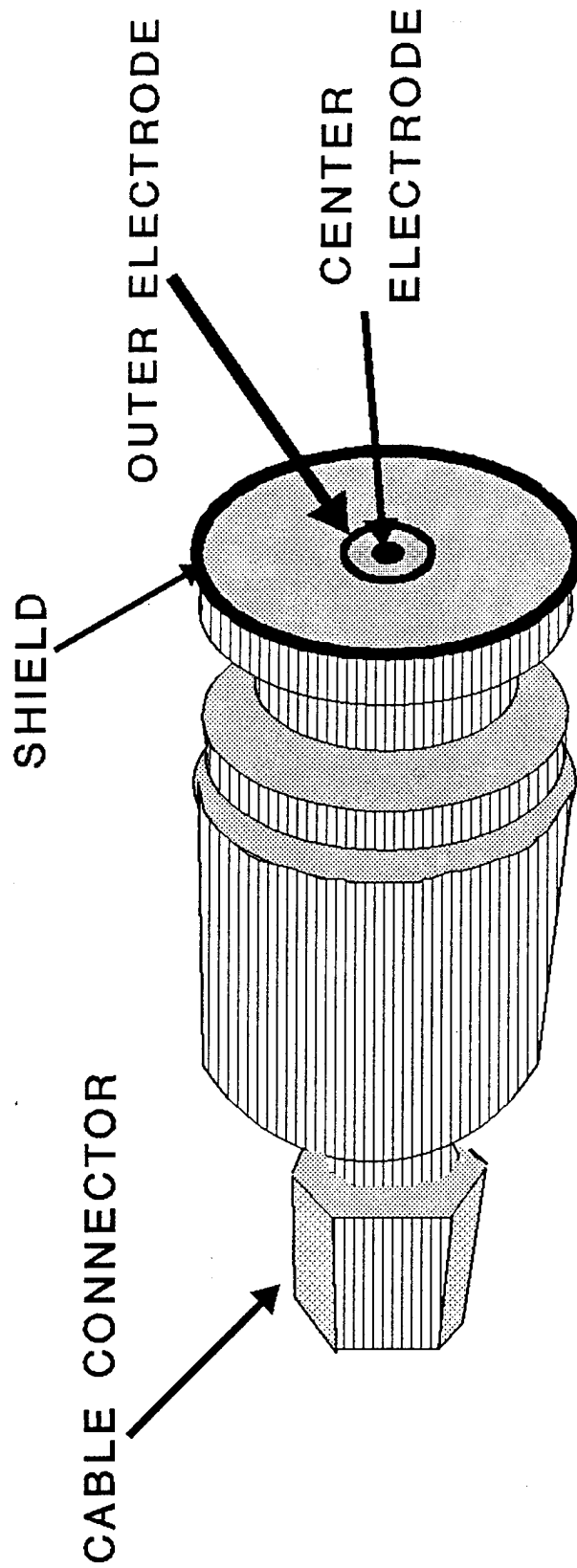
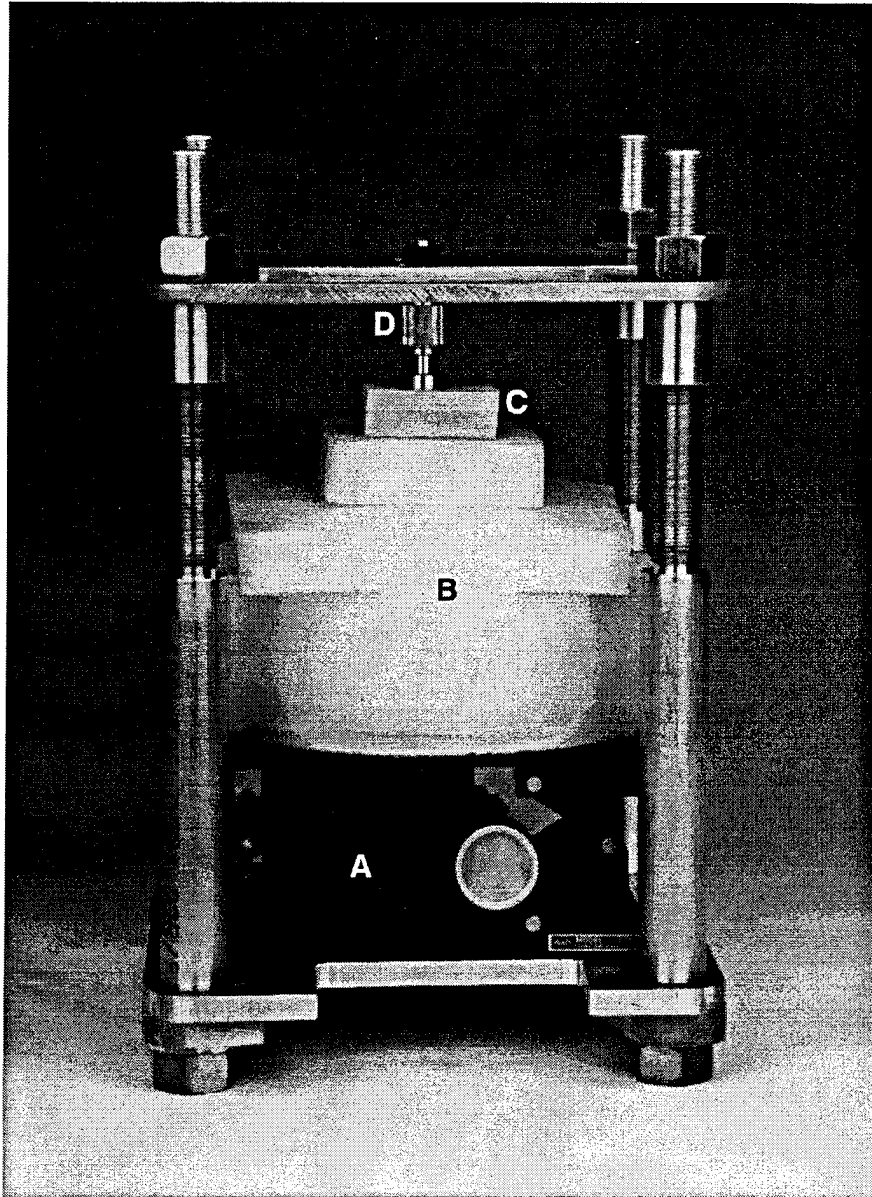

Figure 2. Sketch of the Hewlett Packard Dielectric Probe.



(a) Laboratory jack for height adjustment; (b) Styrofoam; (c) Specimen; (d) Dielectric probe and cable adapter

Figure 3. Material Specimen and Probe Holding Fixture.

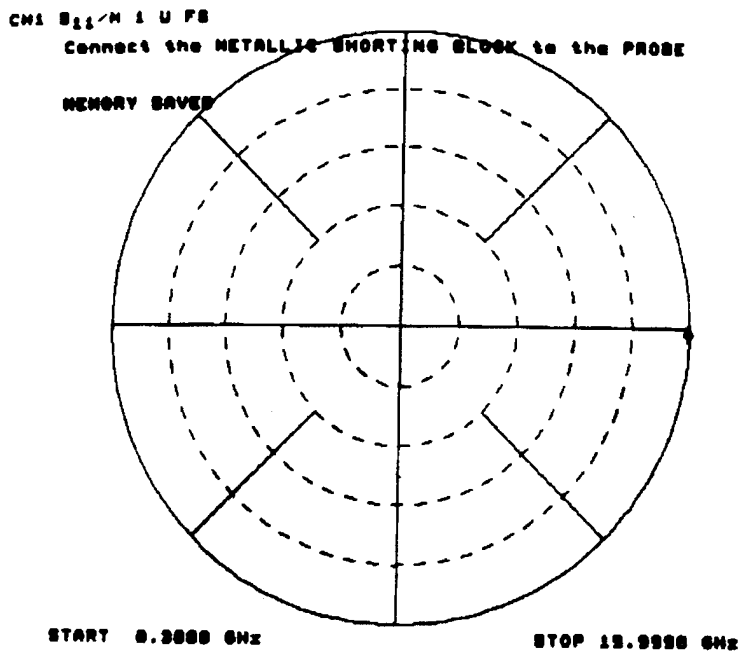

Figure 4. Polar Display without Material Coupled to Probe.

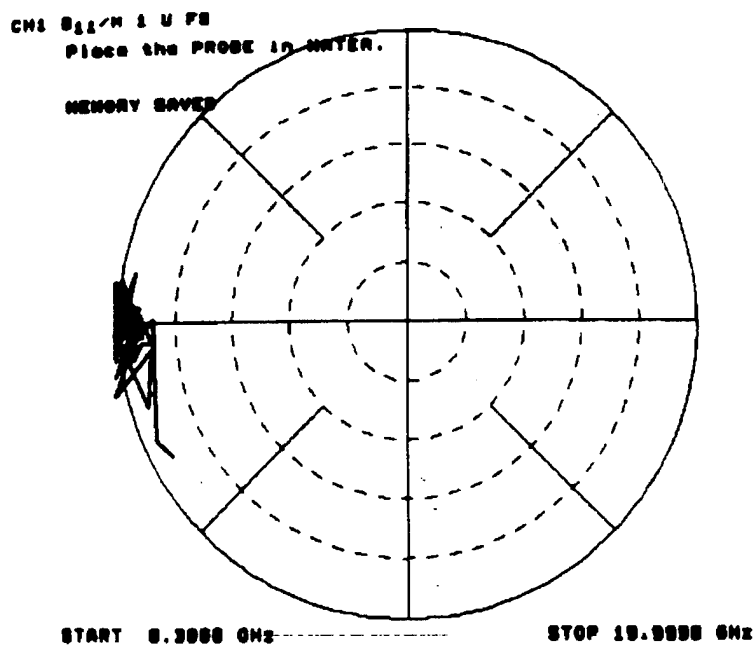

Figure 5. Polar Display with the Probe Shorted.

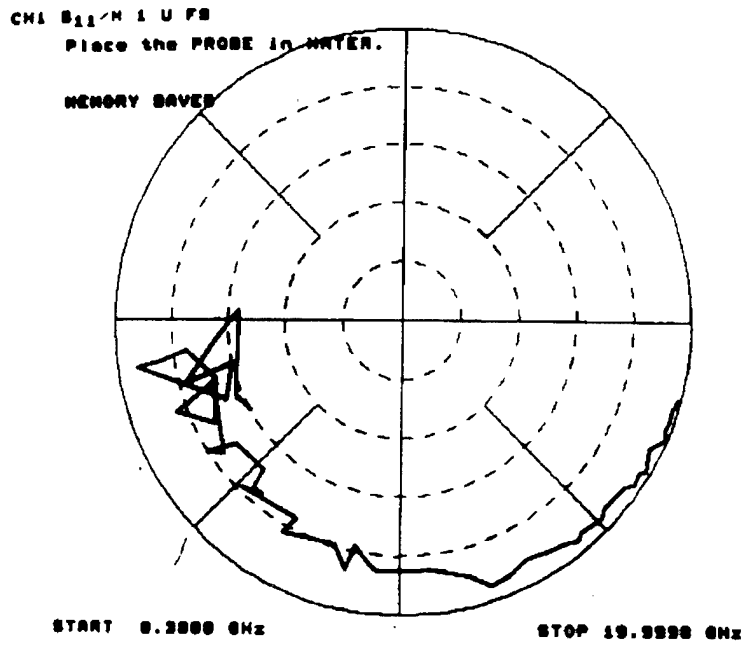
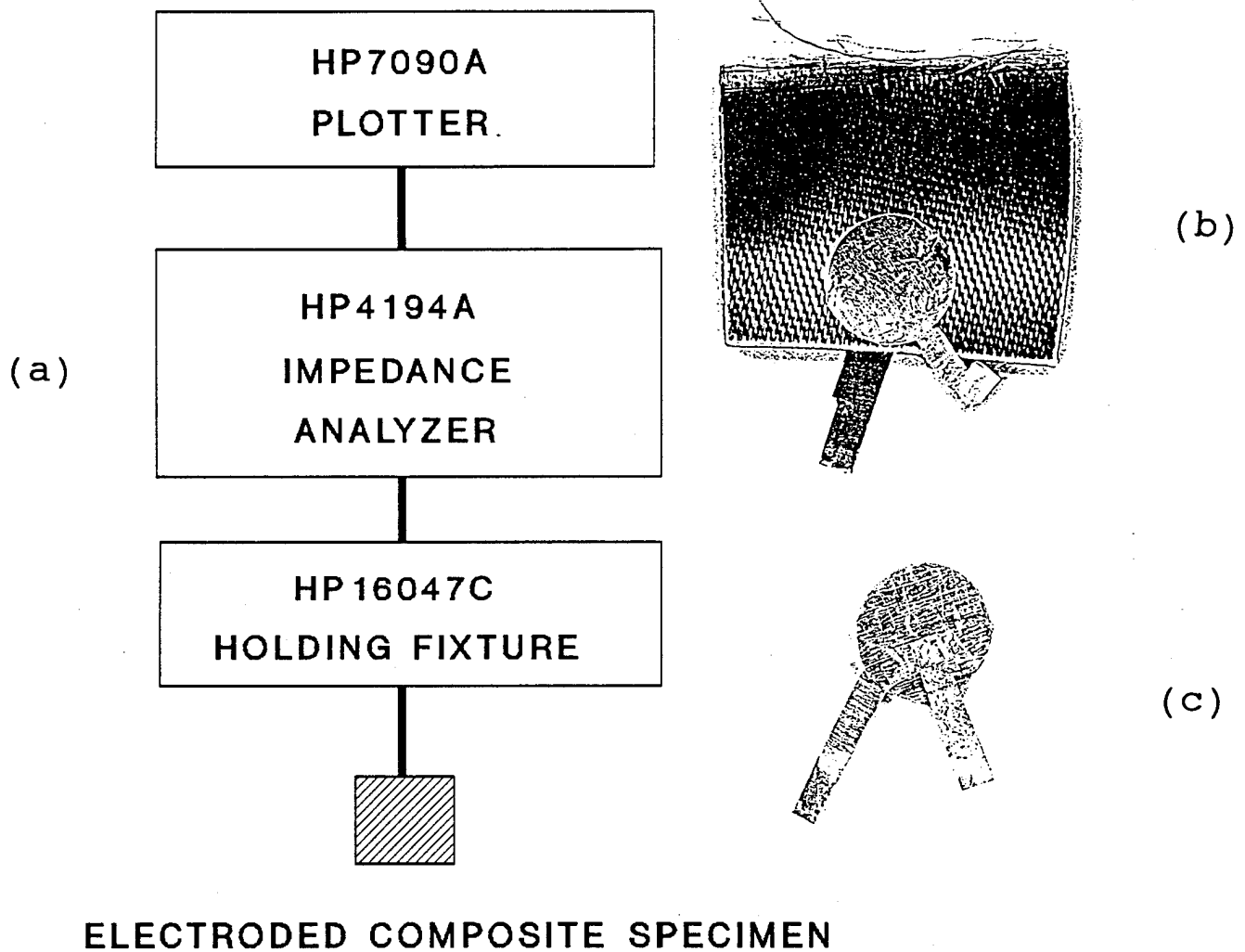

Figure 6. Polar Display with the Probe Submerged in Water.



(a) Measurement system; (b) Specimen with electrodes attached, and (c) Electrodes and glue without material specimen.

Figure 7. Low Frequency (40 MHz) Impedance Analysis of Composite Specimens.

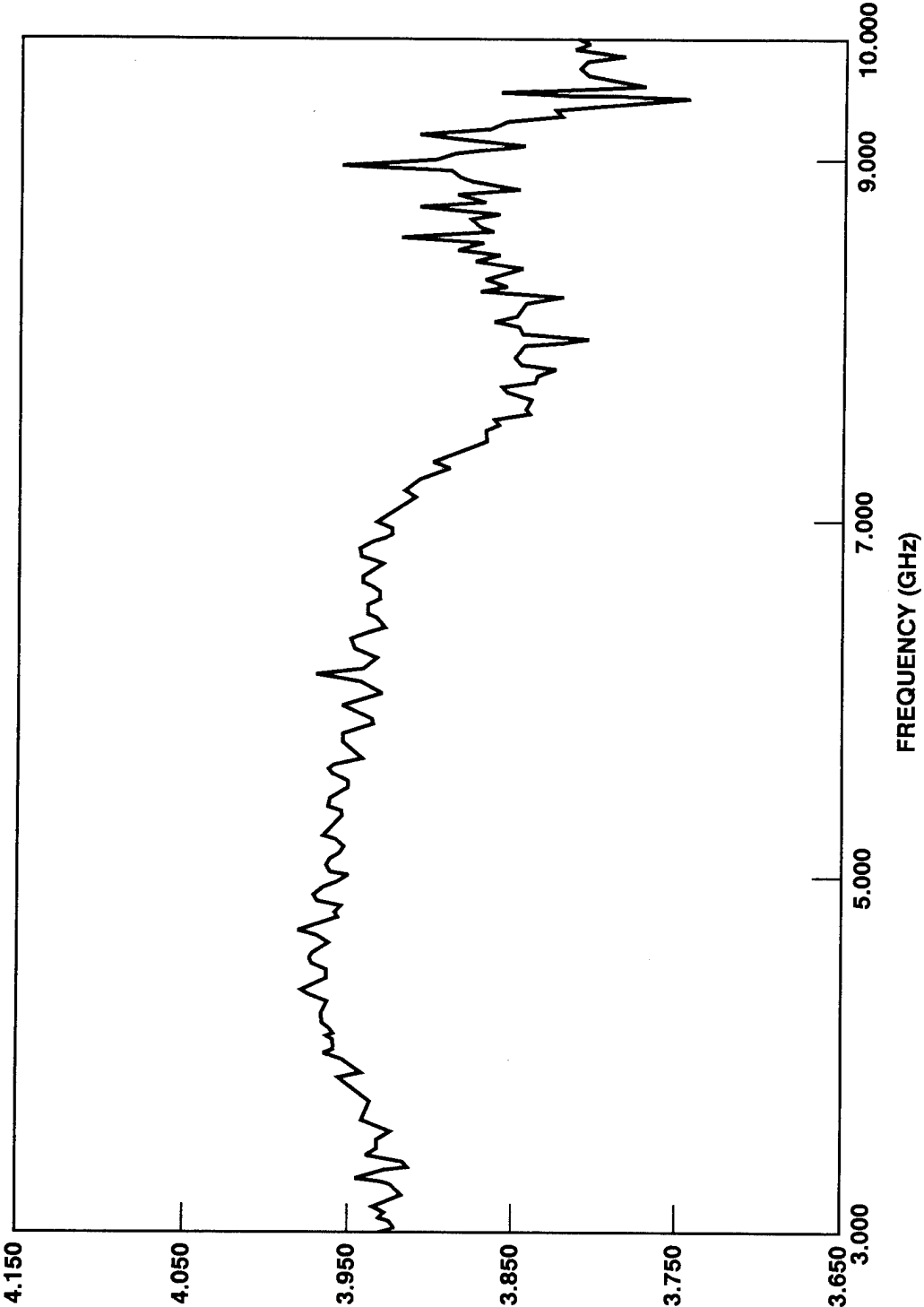
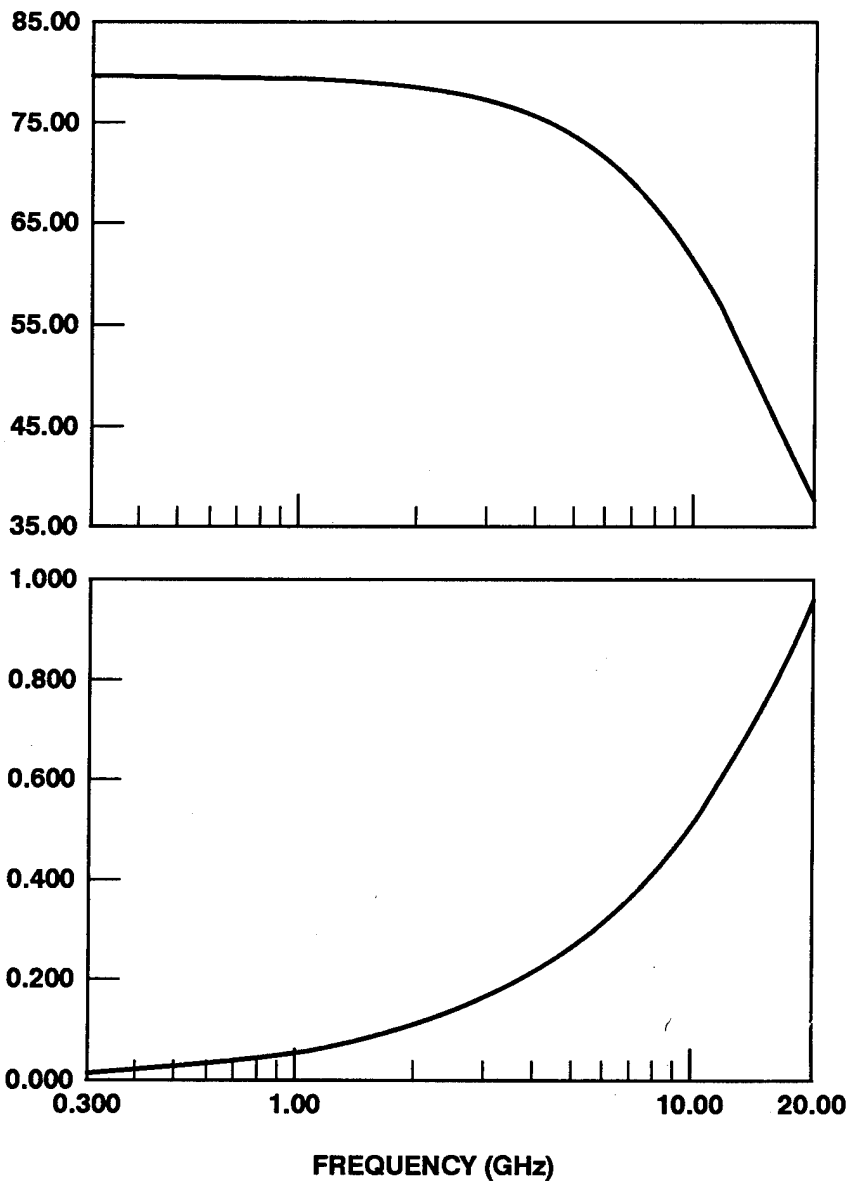
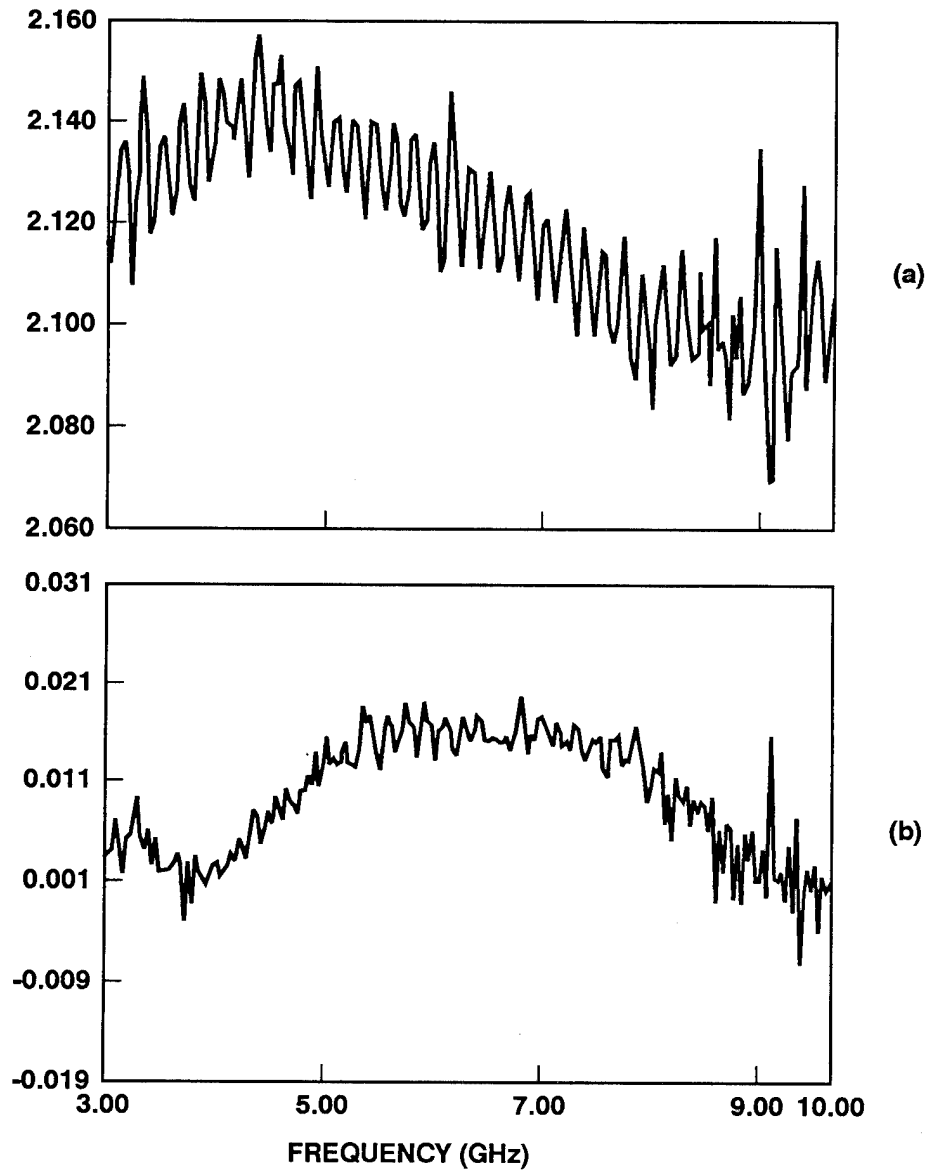

Figure 8. Dielectric Constant of Fused Quartz from 3 to 10 GHz.



(a) Loss tangent; (b) Water

Figure 9. Room Temperature Dielectric Constant of water from 0.2 through 20 GHz.



(a) Loss tangent; (b) Teflon

Figure 10. Dielectric Constant of Teflon from 0.2 through 20 GHz.

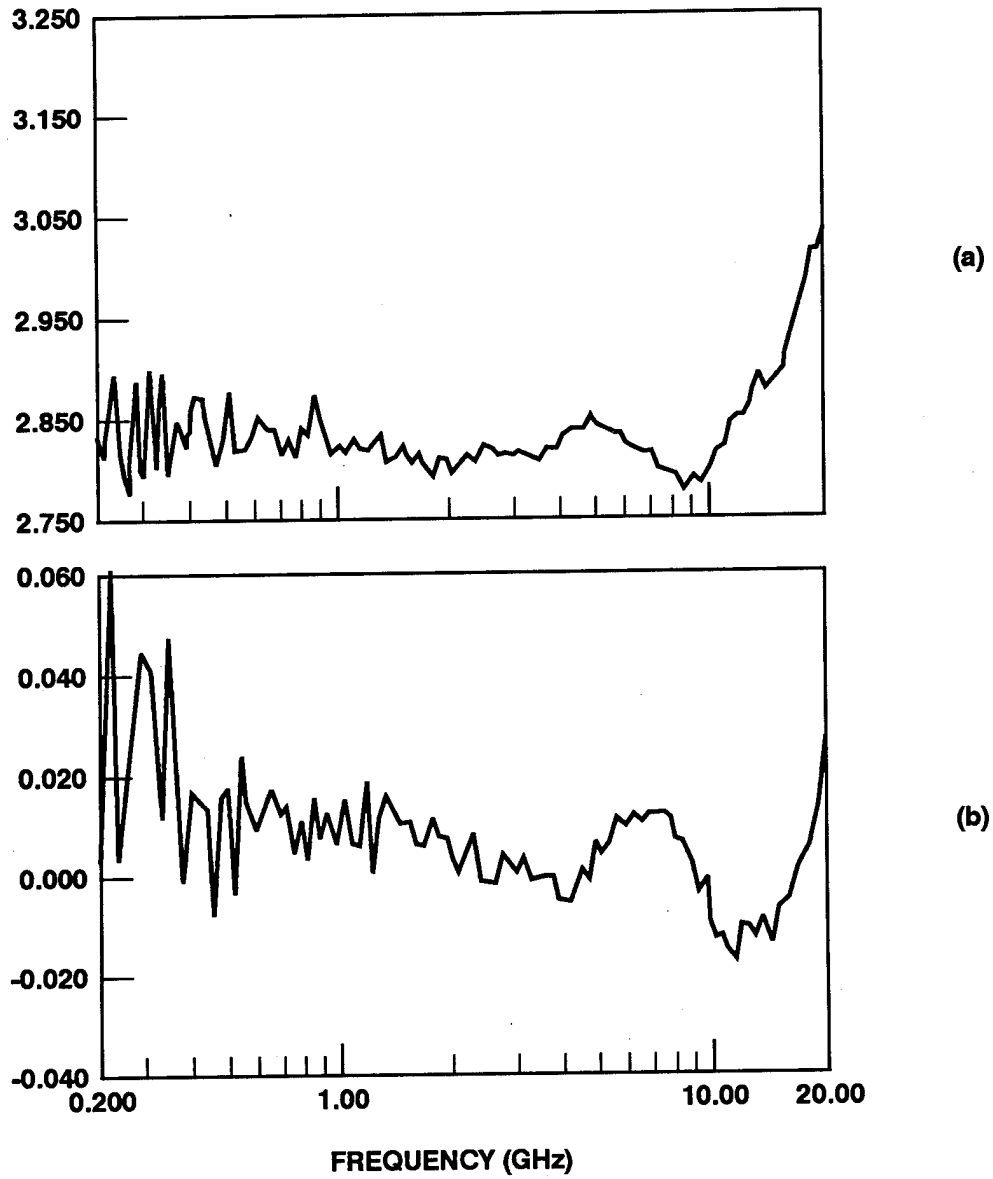

(a) Loss tangent; (b) Lucite

Figure 11. Dielectric Constant of Lucite from 0.2 through 20 GHz.

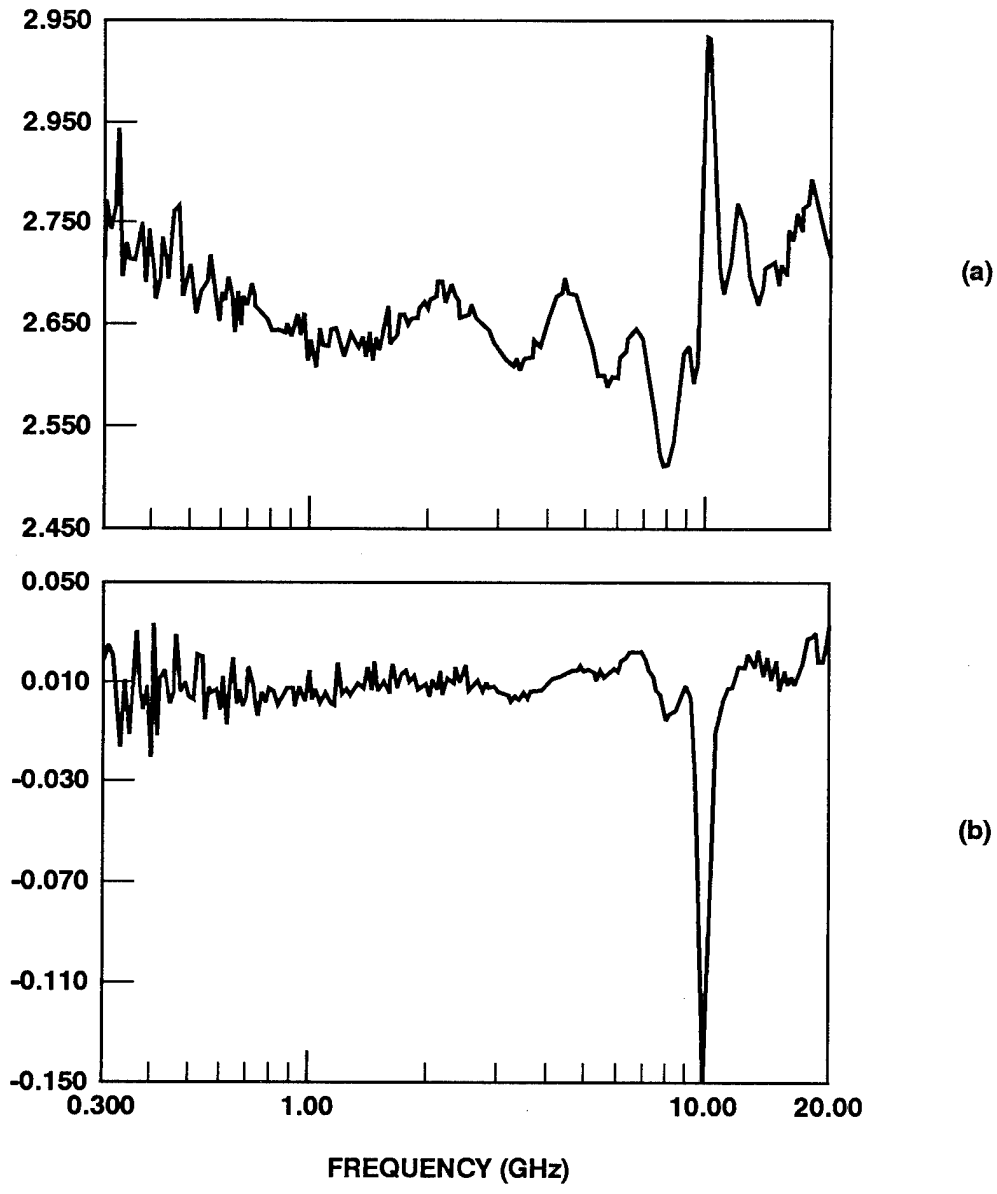

(a) Loss tangent; (b) Polished, two layers thick composite Spectra/VE8084

Figure 12. Dielectric Constant of Polished, Two Layers Thick Composite Spectra/VE8084 from 0.2 through 20 GHz.

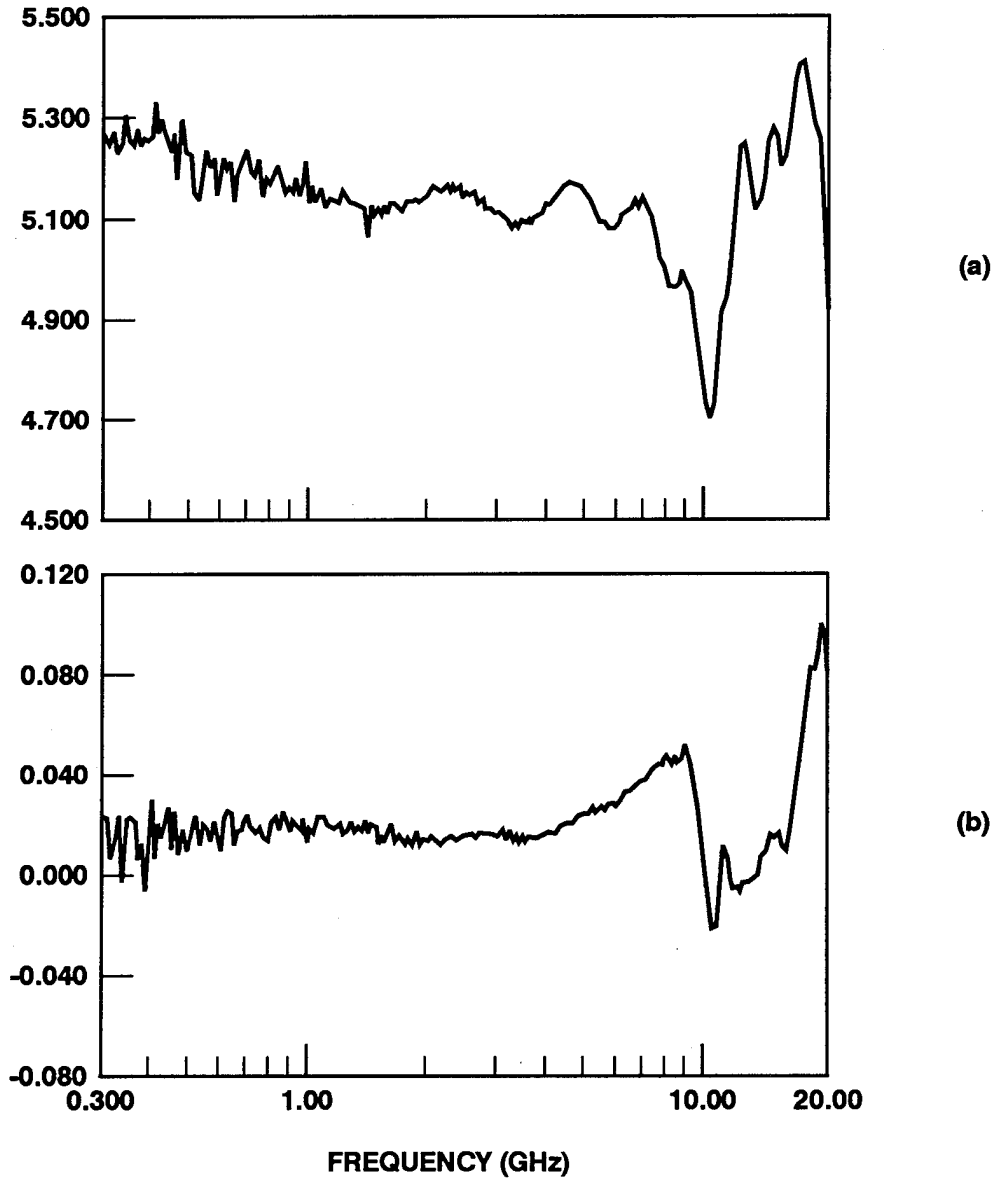

(a) Loss tangent; (b) Polished, two layers thick composite WR/8510-9

Figure 13. Dielectric Constant of Polished, Two Layers Thick Composite WR/8510-9 from 0.2 through 20 GHz.

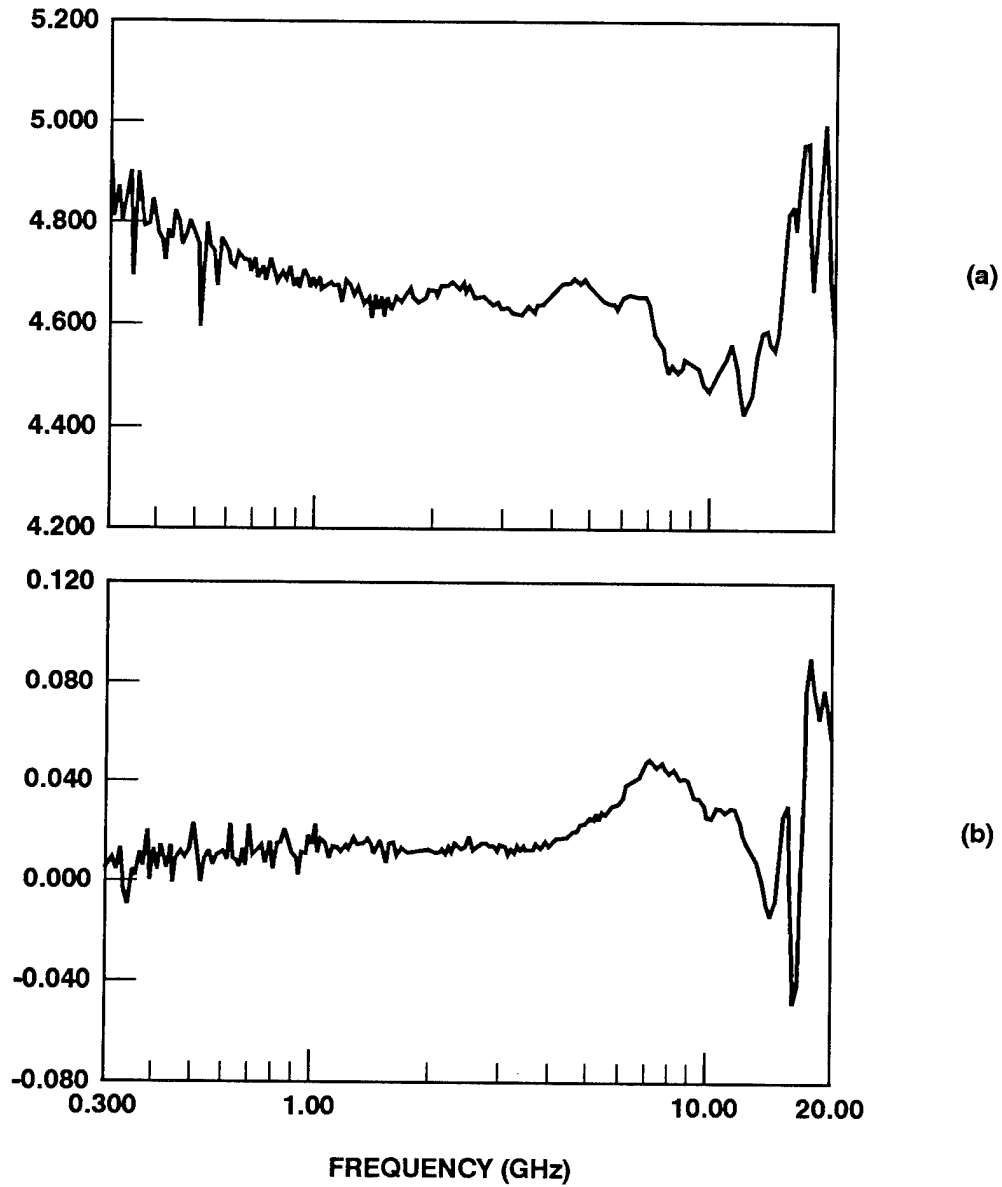

(a) Loss tangent; (b) Polished, two layers thick composite WR/VE510A

Figure 14. Dielectric Constant of Polished, Two Layers Thick Composite WR/VE510A from 0.2 through 20 GHz.

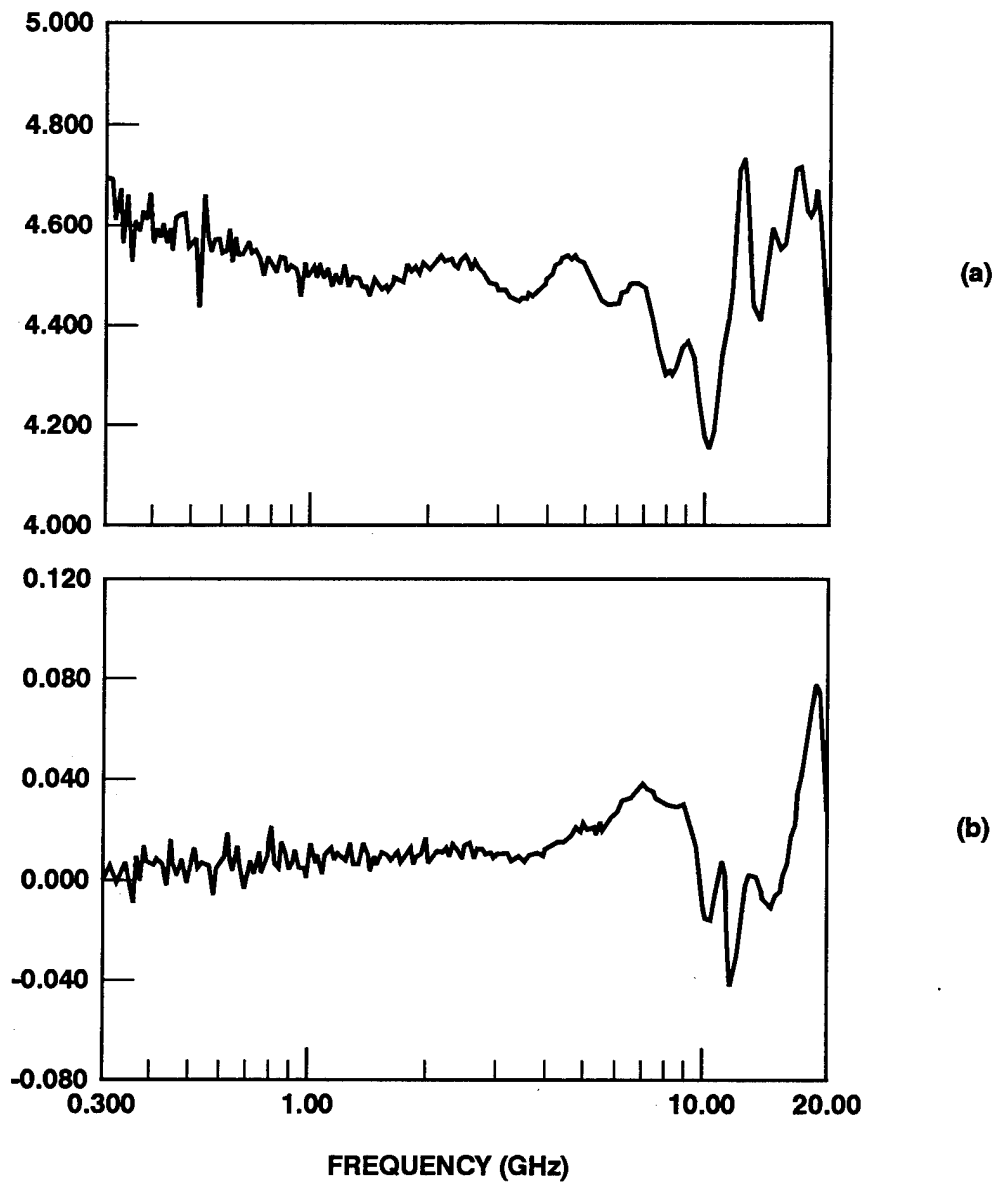

(a) Loss tangent; (b) Polished, two layers thick composite BIA/EG/VE510A

Figure 15. Dielectric Constant of Polished, Two Layers Thick Composite BIA/EG/VE510A from 0.2 through 20 GHz.

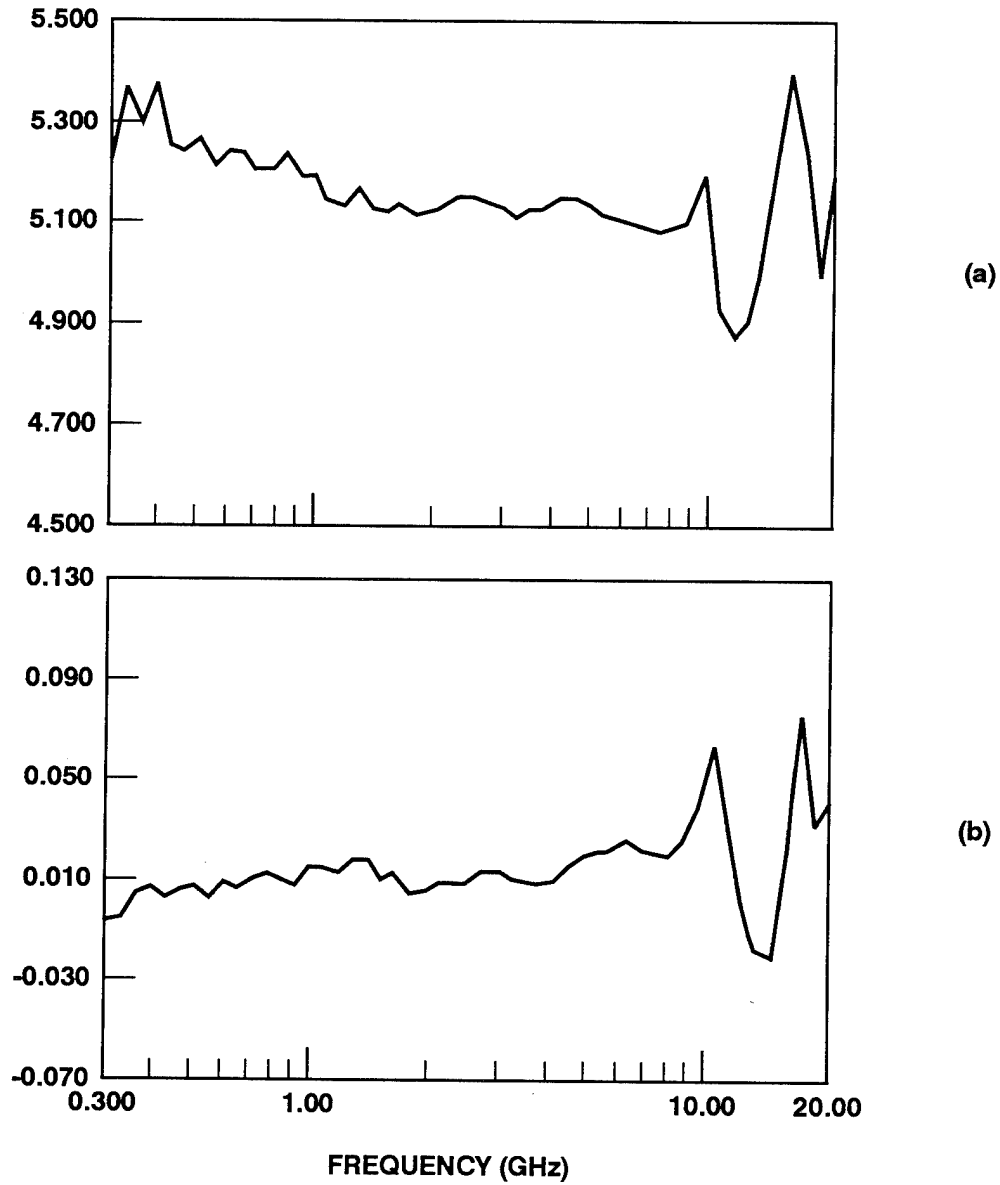

(a) Loss tangent; (b) Polished, two layers thick composite WR/Spectra 50P/VE510A

Figure 16. Dielectric Constant of Polished, Two Layers Thick Composite WR/Spectra 50P/VE510A from 0.2 through 20 GHz.

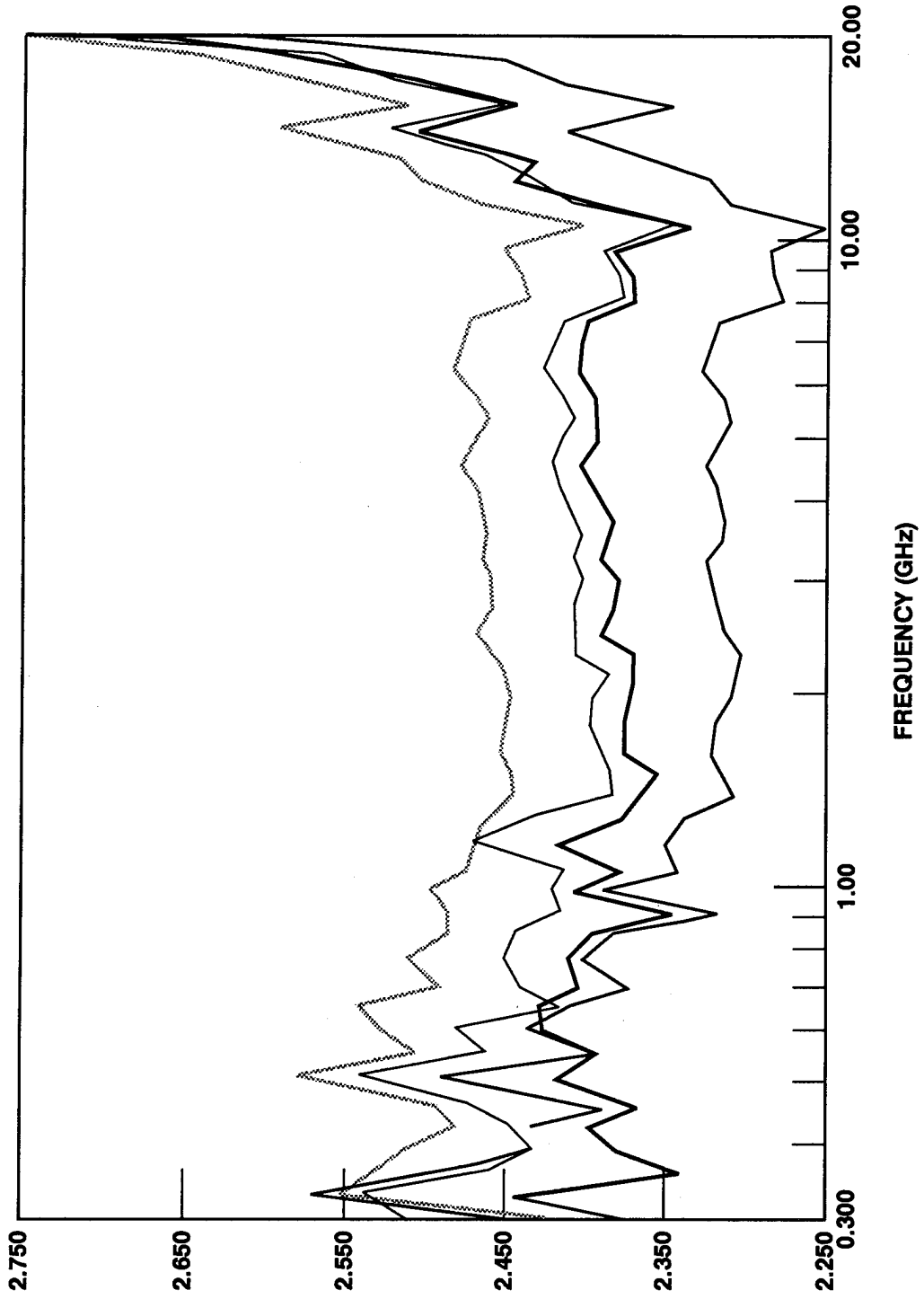
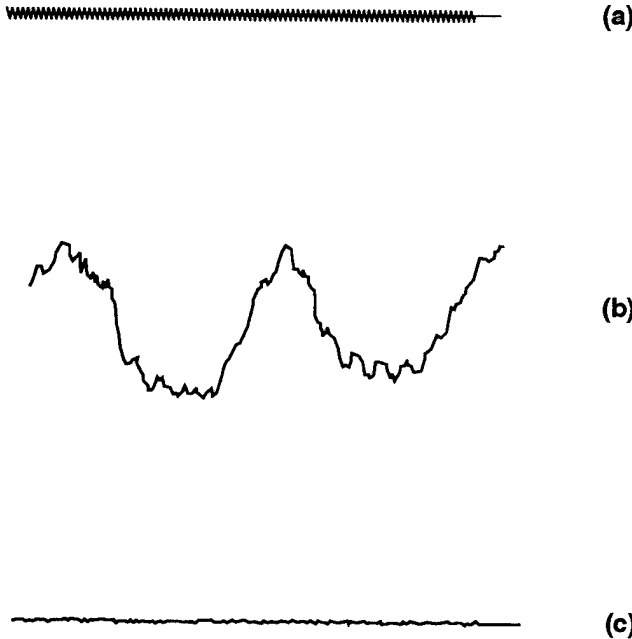

Figure 17. Apparent Dielectric Constant at Four Locations 0.020 inch Apart on Unpolished Composite WRVE510A.



(a) Standard with a roughness value, Ra = 6 microns; (b) Typical trace for the rough surface; (c) Typical trace for the polished surface

Figure 18. Surface Profilometry on Composite WR/VE510A.

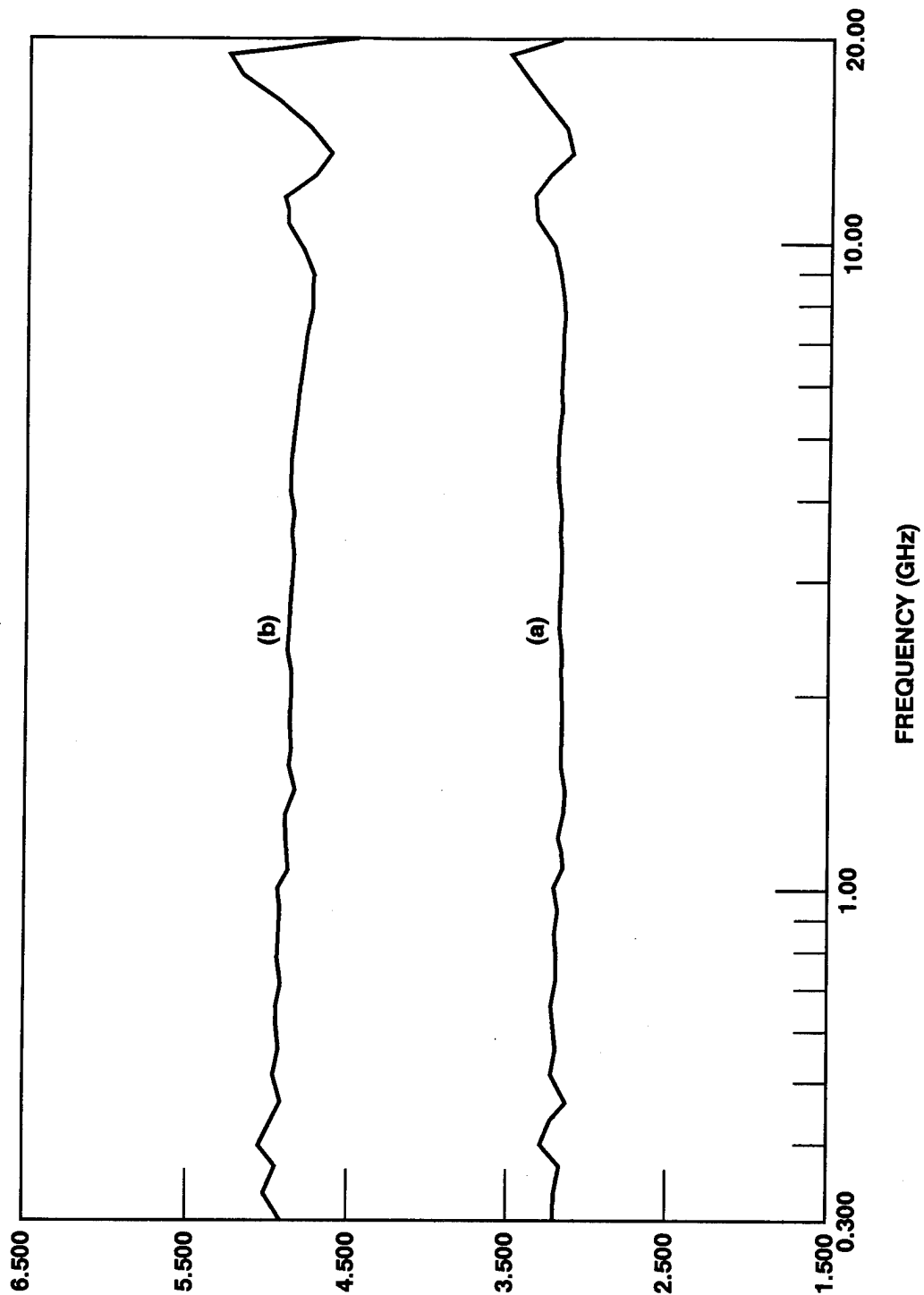
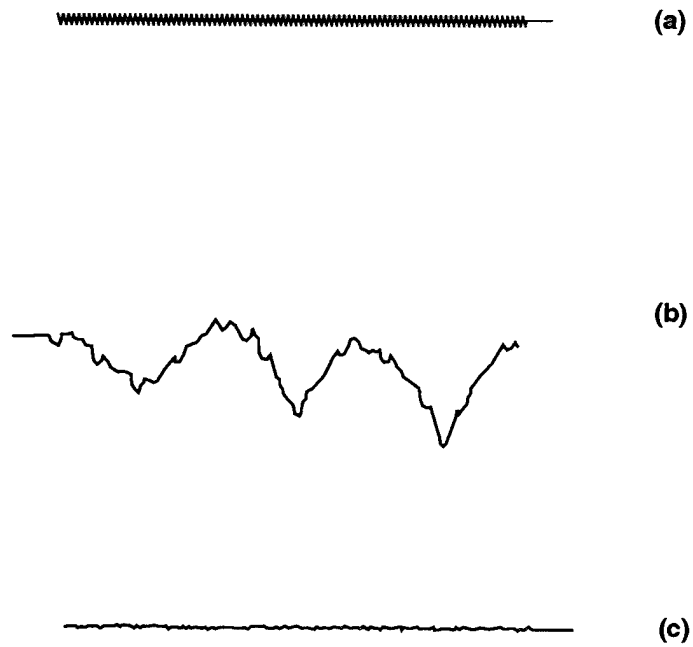

Figure 19. Apparent Dielectric Constant at Four Locations of Unpolished and Polished Composite 7781/510A.



(a) Standard with a roughness value, $R_a = 6$ microns; (b) Typical trace for the rough surface;
(c) Typical trace for the polished surface

Figure 20. Surface Profilometry on Composite 7781/510A.

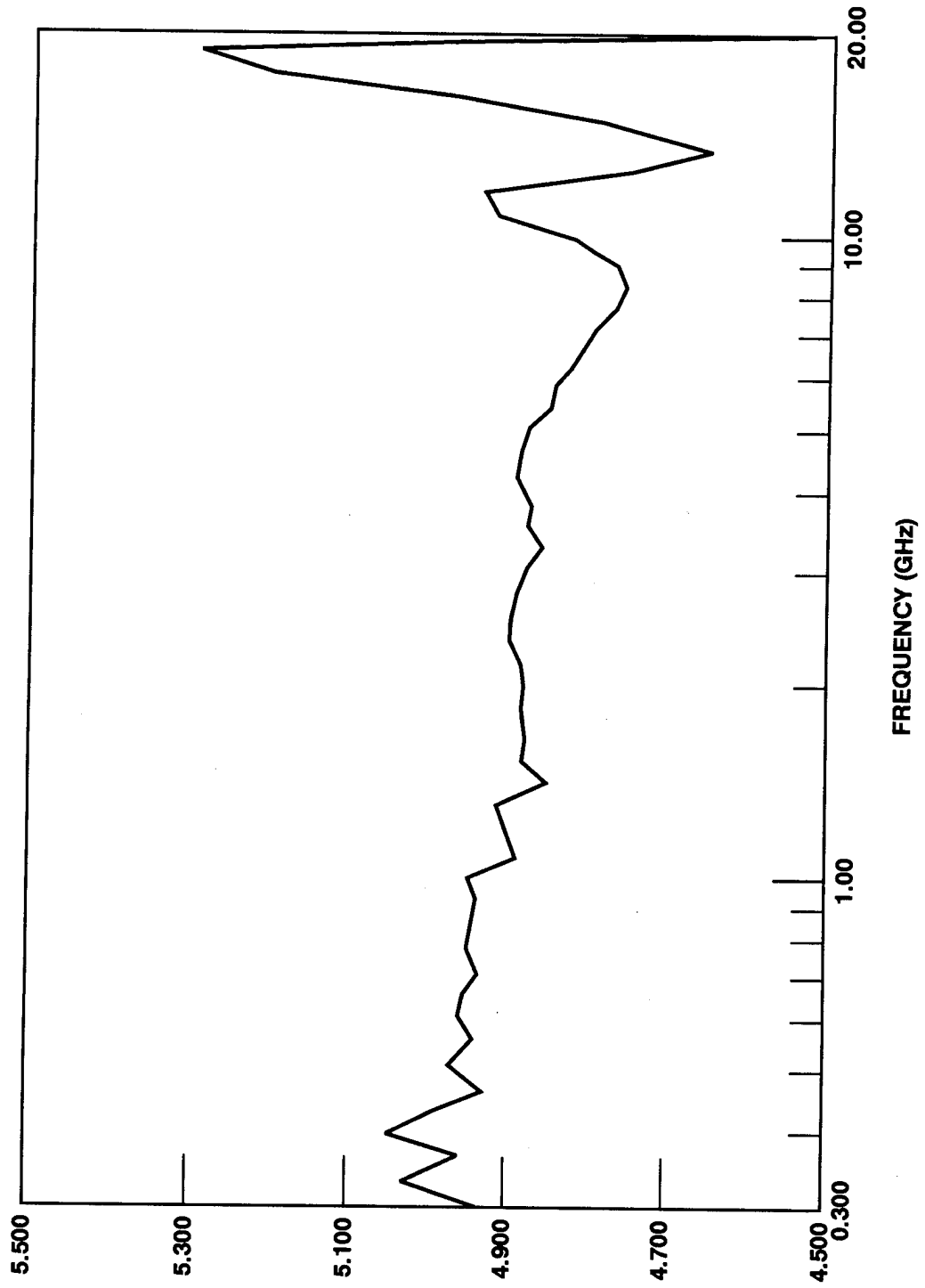

Figure 21. Apparent Dielectric Constant for a Single Layer, Polished Composite 7781/510A.

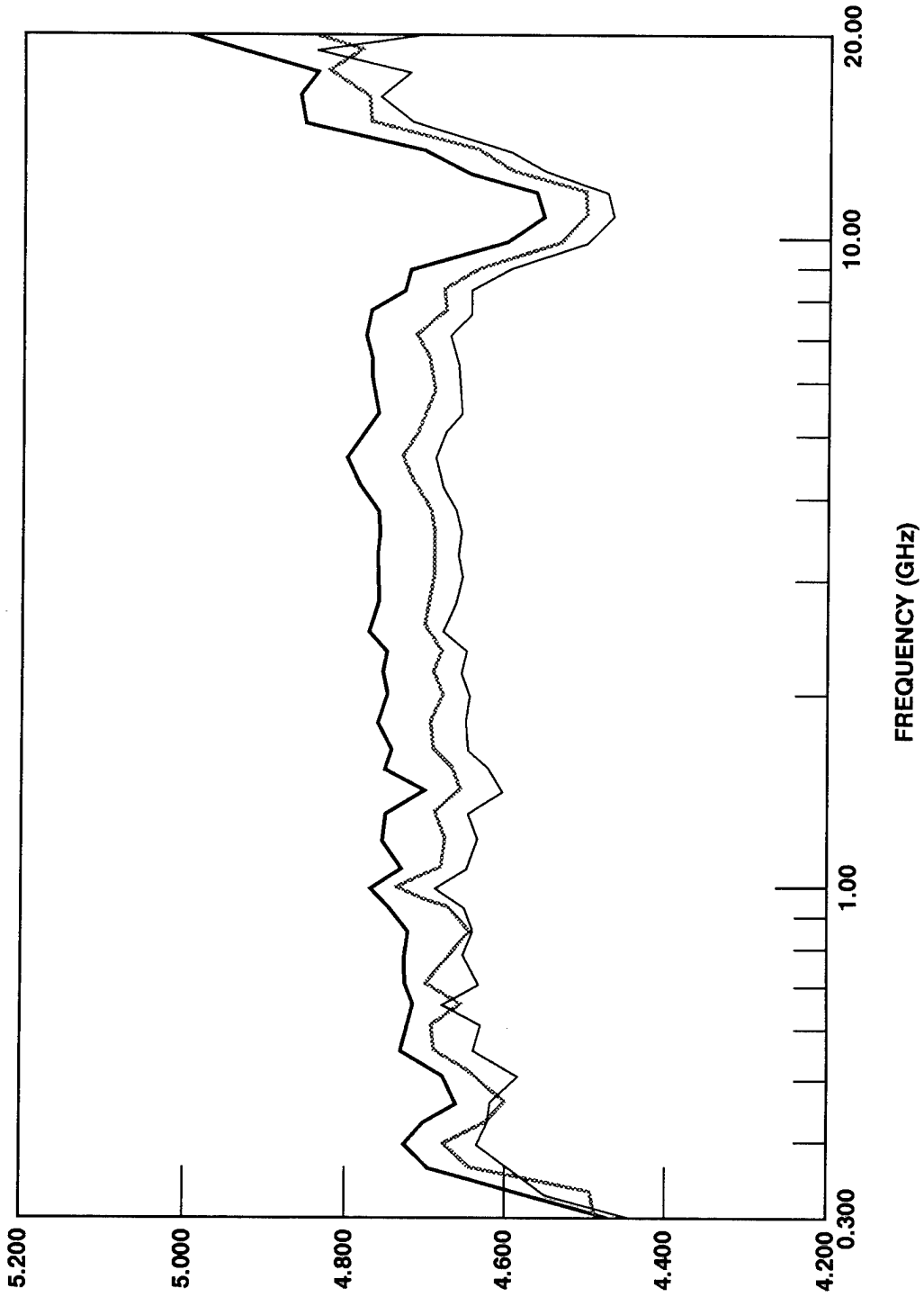

Figure 22. Apparent Dielectric Constant for a Two-Layer Stack, Polished Composite 7781/510A.

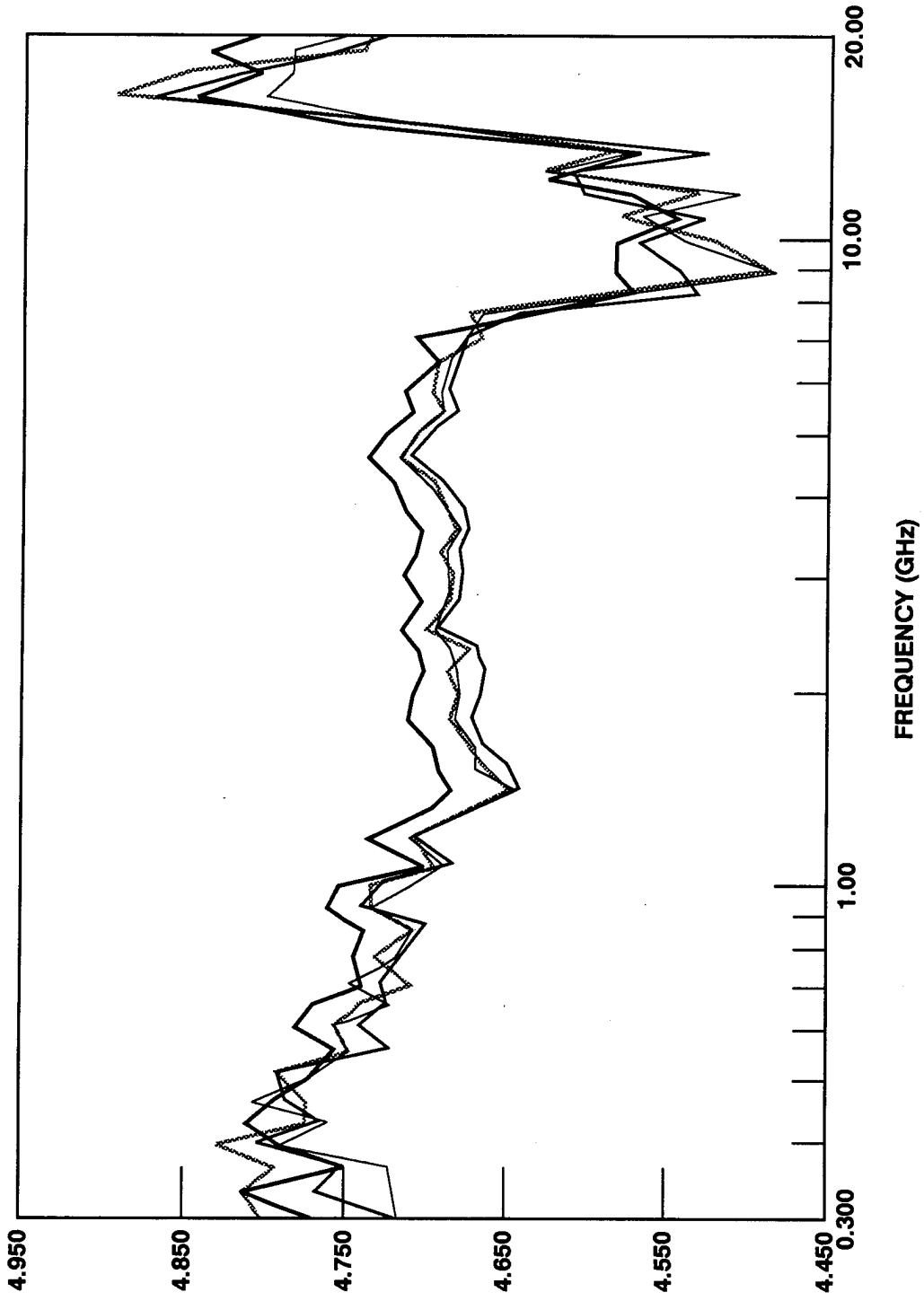

Figure 23. Apparent Dielectric Constant for a Three-Layer Stack, Polished Composite 7781/510A.

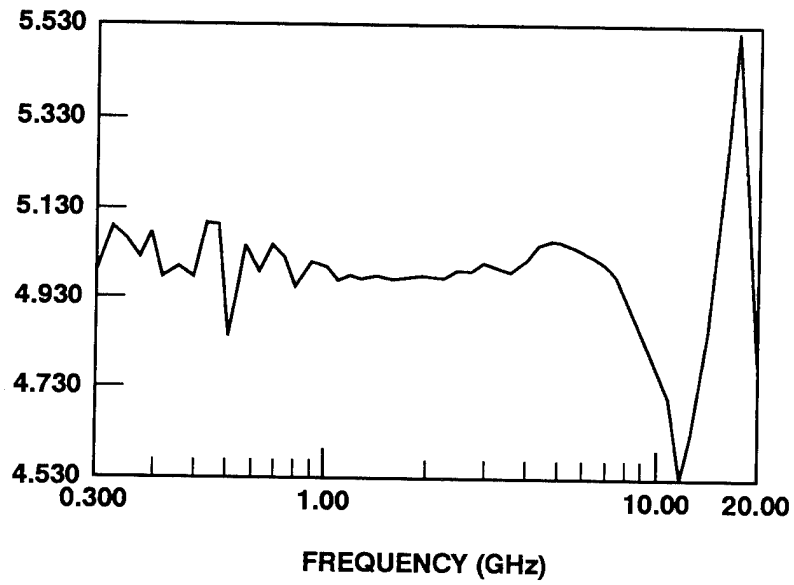

Figure 24. Apparent Dielectric Constant of a Single-Layer, Polished Composite WR/8510-9.

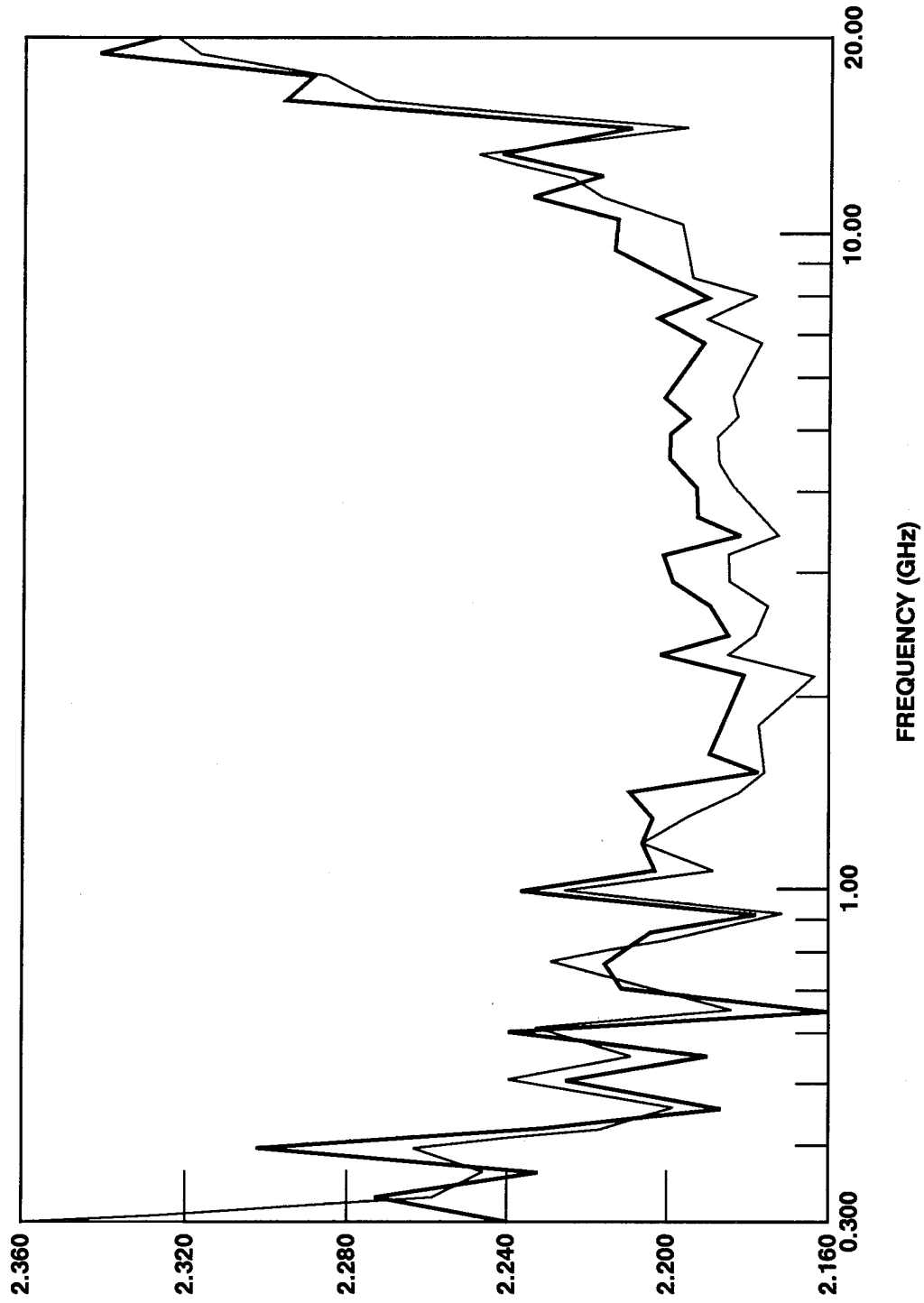

Figure 25. Apparent Dielectric Constant of a Stack of Two Unpolished Layers of WRVE510A.

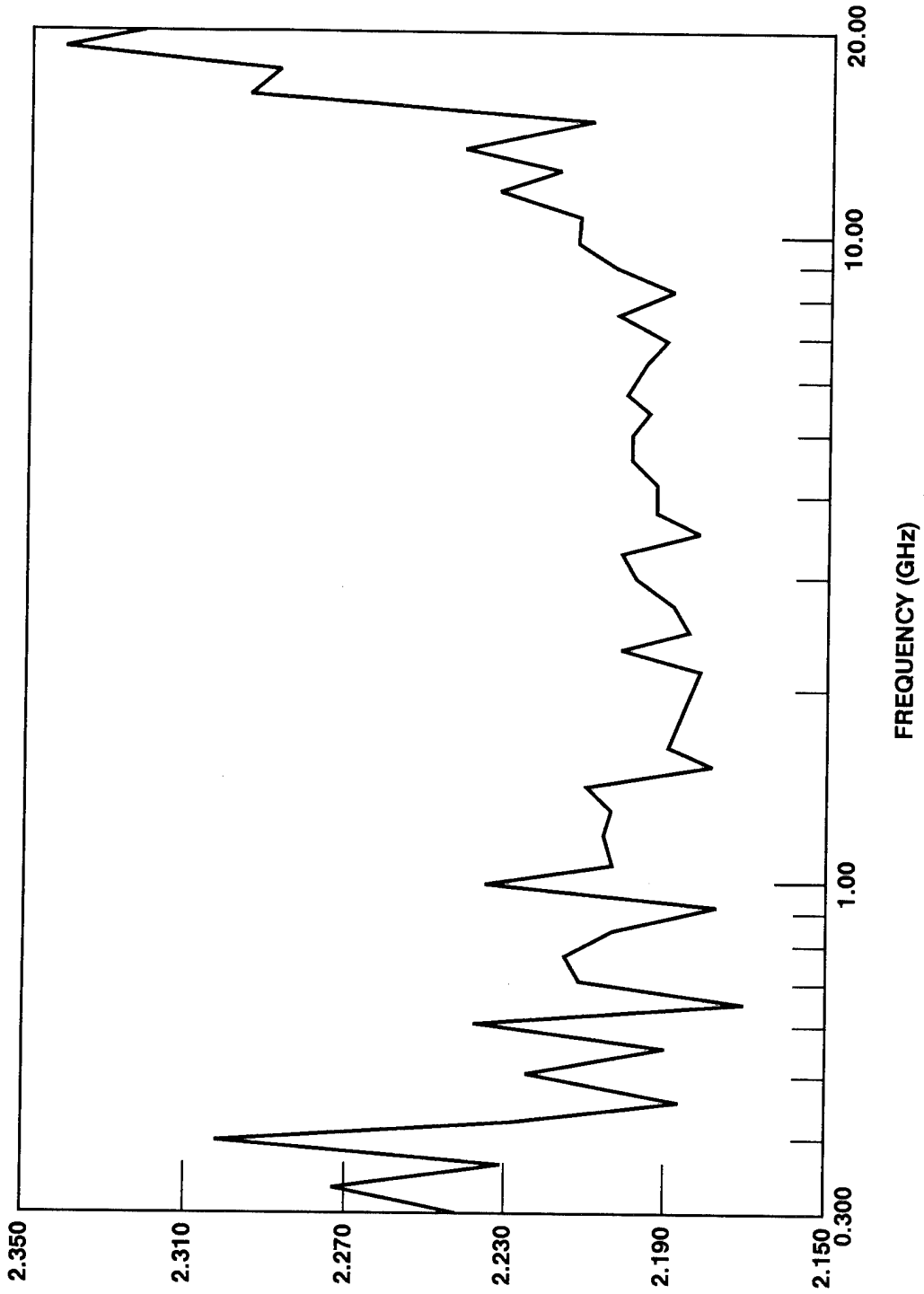

Figure 26. Apparent Dielectric Constant of a Stack of Three Unpolished Layers of WRVE510A.

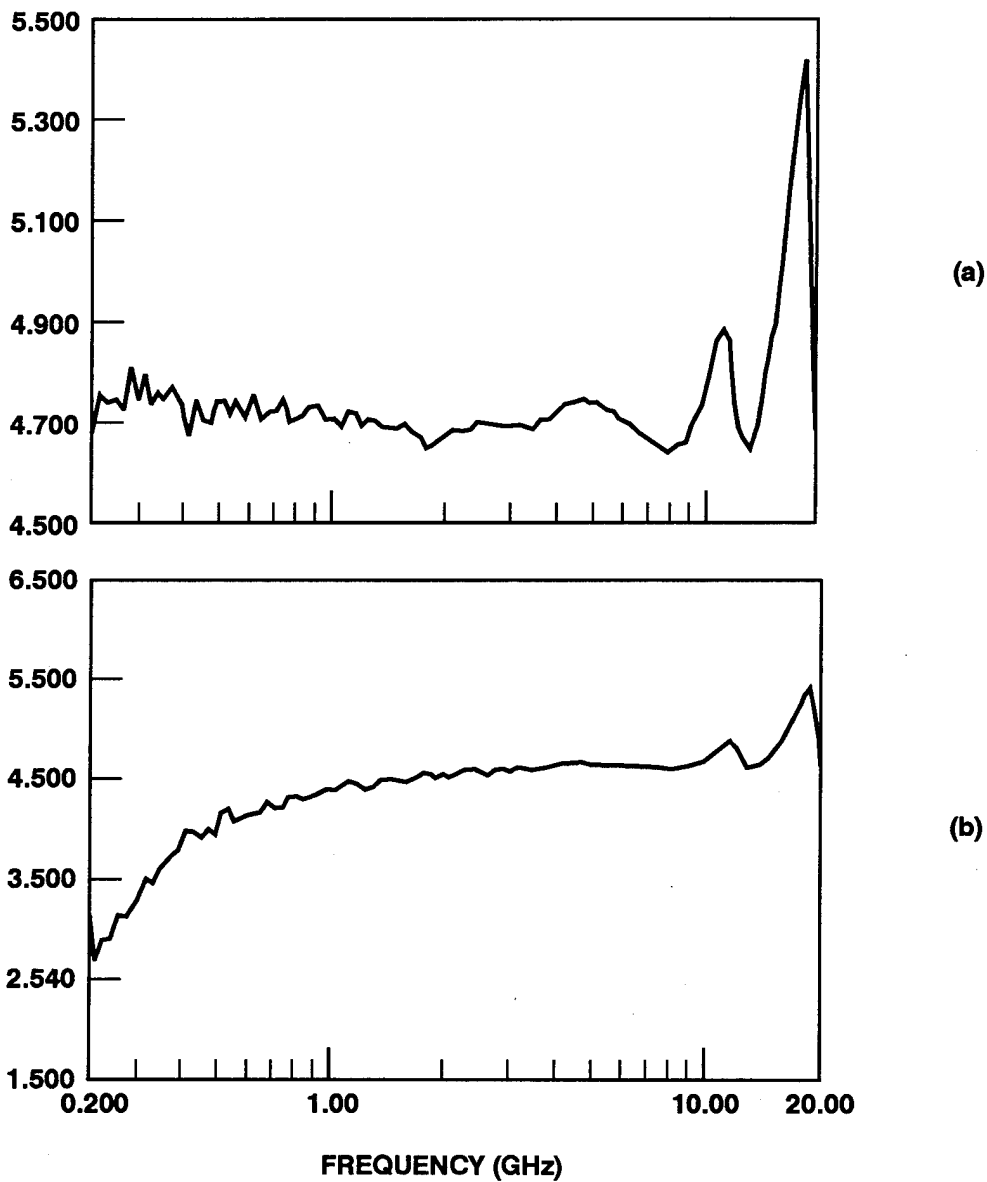
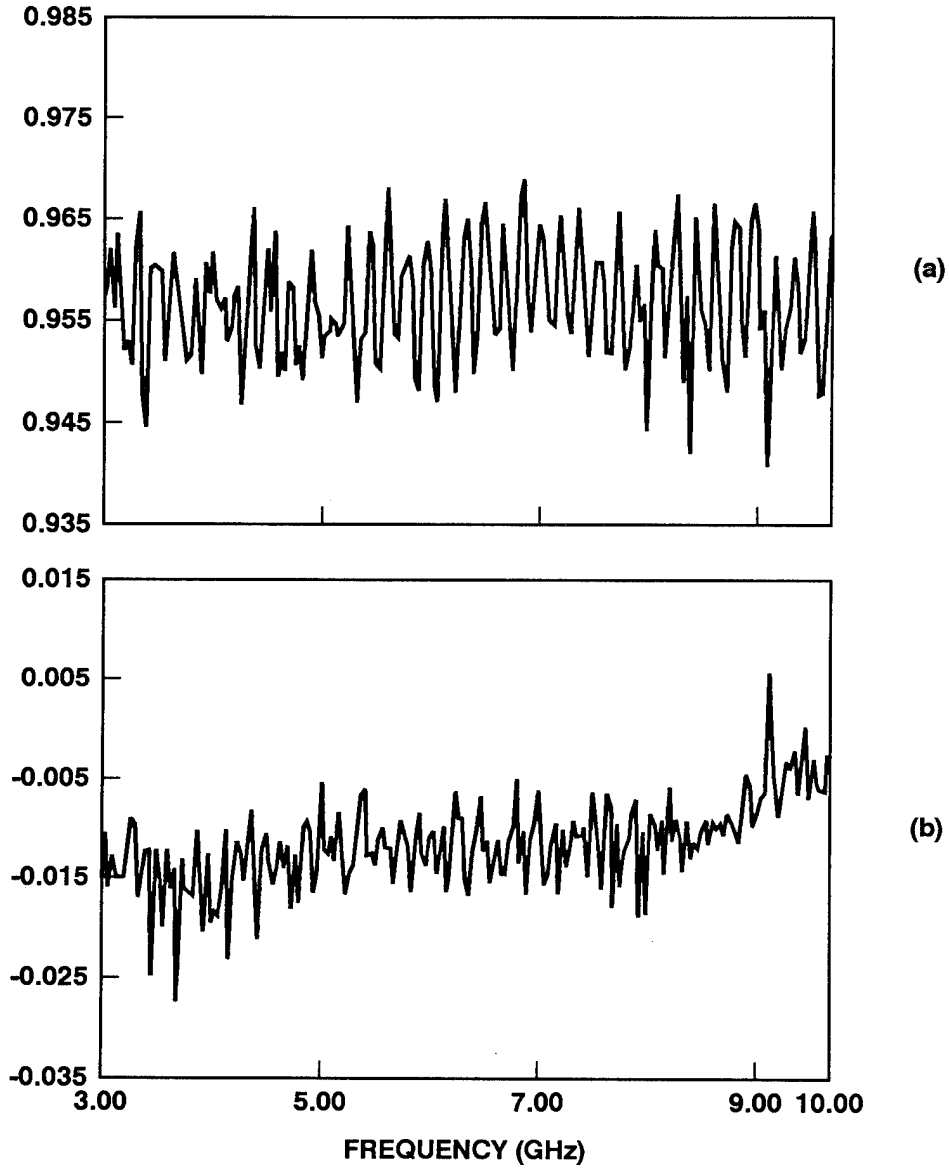
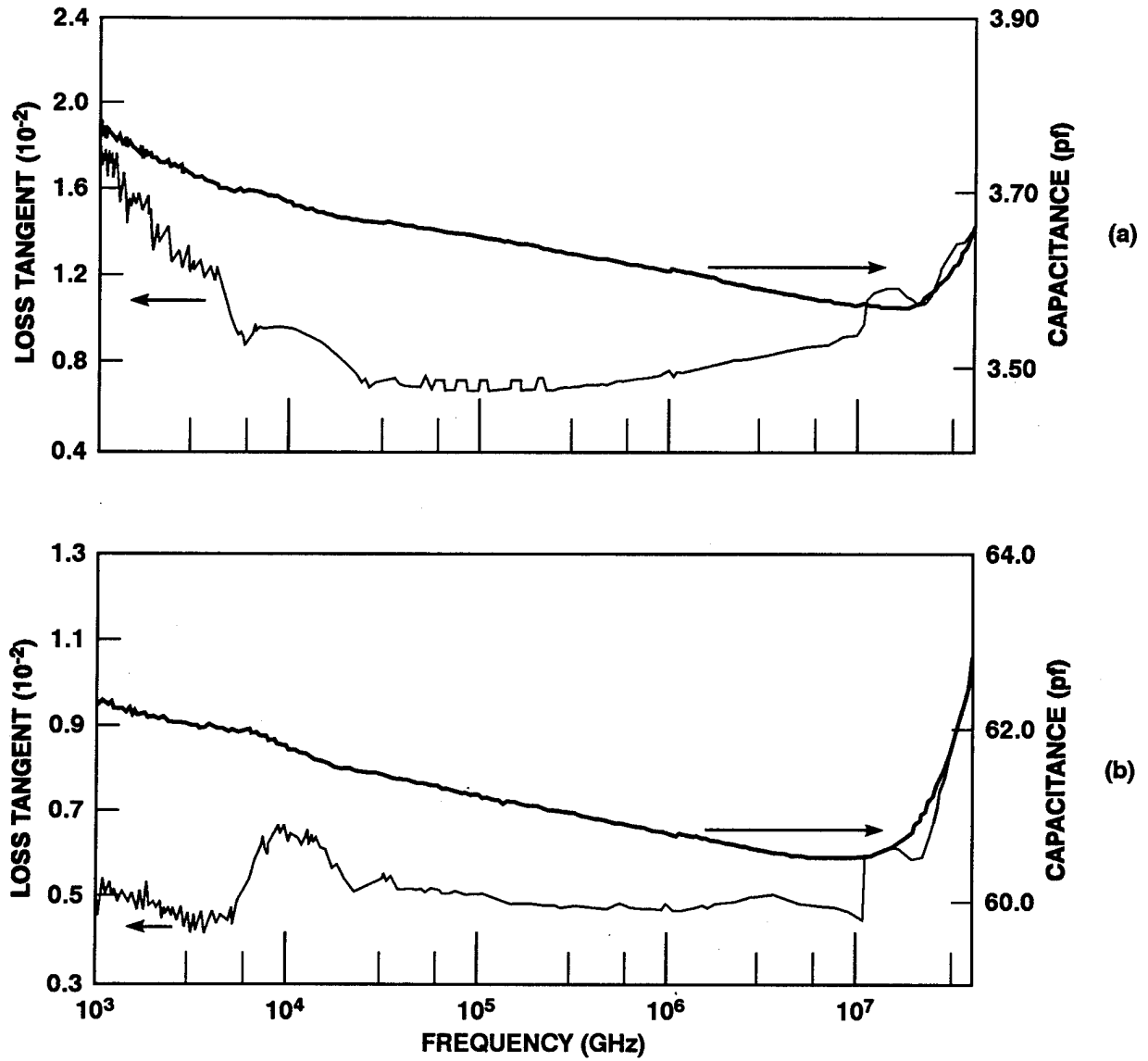

Figure 27. Apparent Dielectric Constant of Composite 7781/510A Using Two Different Calibrations.



(a) Loss tangent; (b) Dielectric constant

Figure 28. Dielectric Constant Measured When the Probe Was Not Coupled to Material.



(a) Electroded composite 7781/510A; (b) Electroded glue without specimen.

Figure 29. Capacitance and Loss Versus Frequency.

REFERENCES

1. Mosig, J. R., Besson, J. E., Gex-Fabry, M., and Gardiol, F. E., "Reflection of an Open-Ended Coaxial Line and Application to Nondestructive Measurement of Materials," *IEEE Transactions on Instrumentation and Measurement*, Vol. IM-30, No. 1, page 46, 1981.
2. Misra, D. K., "A Quasi-Static Analysis of Open-Ended Coaxial Lines," *IEEE Transactions on Microwave Theory & Techniques*, Vol. MTT-35, No. 10, page 925, 1987.
3. Misra, D. E., Chhabra, M., Epstein, B. R., Mirotznik, M., and Foster, K. F., "Noninvasive Electrical Characterization of Materials at Microwave Frequencies Using an Open-Ended Coaxial Line: Test of an Improved Calibration Technique," *IEEE Transactions on Microwave Theory & Techniques*, Vol. MTT-38, No. 1, page 8, 1990.
4. Colpitts, B. G., "Temperature Sensitivity of Coaxial Probe Complex Permittivity Measurements: Experimental Approach," *IEEE Transactions on Microwave Theory & Techniques*, Vol. MTT-41, No 2, page 229, 1993.
5. *Technical Data*, 85070A Dielectric Probe Kit, Hewlett Packard Corp, 1991.
6. *Dielectric Material Measurement Forum-Measurement Fundamentals*, Hewlett Parkard Corp., 1993.
7. *Users Manual*, 85070A Dielectric Probe Kit, Hewlett Parkard Corp., 1991.
8. M. N. Afsar and K.J. Button, "Precise Millimeter-Wave Measurements of Complex Refractive Index, Complex Dielectric Permittivity and Loss Tangent of GaAs, Si, SiO₂, AL₂O₃, BeO, Macor, and Glass," *IEEE Transactions on Microwave Theory & Techniques*, Vol. MTT-31, No. 2, page 217, February 1983.
9. A.R. von Hippel, ed. *Dielectric Materials and Applications*, MIT Press, Cambridge, MA, 1954.
10. A.J. Bahr, *Microwave Nondestructive Testing Methods*, page 31, Gordon & Breach Science Publisher, 1982.
11. M.N. Afsar, "Precision Millimeter-Wave Measurements of Complex Refractive Index, Complex Dielectric Permittivity, and Loss Tangent of Common Polymers," *IEEE Transactions on Instrumentation and Measurement*, Vol. IM-36, No. 2, page 530, June 1987.
12. Ghodgaonkar, D. K., Varadan, V. V, Varadan, V. K., "A Free- Space Method for Measurement of Dielectric Constants and Loss Tangents at Microwave Frequencies," *IEEE Transactions on Instrumentation and Measurement*, Vol. IM-38, No. 3, page 789, 1989.
13. Zoughi, R. and Lujan, M., "Nondestructive Microwave Thickness Measurement of Dielectric Slabs," *Materials Evaluation*., Vol. 48, No. 9, page 1100, 1990.

14. Bakhtiari S. and Zoughi, R., "Microwave Thickness Measurement of Lossy Layered Dielectric Slabs Using Incoherent Reflectivity," *Res. Nondestr. Evaluation.*, 2, 157, 1990.
15. Varadan V. V., Hollinger, R. D., Ghodgaonkar, D. K., and Varadan, V. K., "Free-Space, Broadband Measurements of High-Temperature, Complex Dielectric Properties at Microwave Frequencies," *IEEE Transactions on Instrumentation and Measurement*, Vol. IM-40, No. 5, page 842, 1991.
16. Gagnon, D.R., "Highly Sensitive Measurements with a Lens-focused Reflectometer," *IEEE Transactions on Microwave Theory & Techniques*, Vol. MTT-39, No. 12, page 2237, 1991.
17. Gopalsami, N., Bakhtiari, S., Dieckman, S. L., Raptis, A. C., and Lepper, M. J., "Millimeter-Wave Imaging for Nondestructive Evaluation of Materials," *Materials Evaluation.*, Vol. 52, No. 3, page 412, 1994.

DISTRIBUTION

	<u>Copies</u>		<u>Copies</u>
DOD ACTIVITIES (CONUS)		ATTN DR JERRY BLESSING	1
ATTN ONR 331 (DR RONALD A DEMARCO)	1	NATIONAL INSTITUTE OF STANDARDS AND TECHNOLOGY	
ONR 332 (DR LEWIS SLOTER)	1	ROOM A147 BLDG 233	
ONR 332 (DR ROBERT C POHANKA)	1	GAITHERSBURG MD 20899	
ONR 332 (DR JOHN A SEDRIKS)	1		
OFFICE OF NAVAL RESEARCH		ATTN MOSHE ROSEN	1
BALLSTON TOWER ONE		DEPARTMENT OF MATERIALS SCIENCE AND ENGINEERING	
800 N QUINCY ST		THE JOHNS HOPKINS UNIVERSITY	
ARLINGTON VA 22217-5660		CHARLES & 34TH STREETS	
		BALTIMORE MD 21218	
ATTN CODE 341 (MR TOM FLOYD)	1		
CODE 3423 (D V BEAUREGARD)	1	ATTN PROF JOHN C DUKE	1
OFFICER IN CHARGE		DEPARTMENT OF ENGINEERING SCIENCE AND MECHANICS	
NAVAL UNDERSEA WARFARE CENTER		VIRGINIA POLYTECHNIC INSTITUTE AND STATE UNIVERSITY	
NEW LONDON CT 06320-5594		BLACKSBURG VA 24061	
		NSWC CARDEROCK DIVISION	
ATTN CODE F54 (W P LUCADO)	1	INTERNAL DISTRIBUTION	
CODE B (M E LACEY)	1	0023 REPORTS CONTROL	2
CODE G33 (E J SHULER)	1	011 CORRADO	1
COMMANDER		0119 MESSICK	1
DAHLGREN DIVISION		3021 TIC (Carderock)	1
NAVAL SURFACE WARFARE CENTER		3021 TIC (White Oak)	1
17320 DAHLGREN ROAD		3021 COLEGROVE	1
DAHLGREN VA 22448-5100		601 MORTON	1
		603 CAVALLARO	1
ATTN CODE 824 (S T LEE)	1	615 DENALE	1
COMMANDING OFFICER		633 SARMAN	1
NAVAL COMMAND CONTROL AND OCEAN SURVEILLANCE CENTER RDTE DIVISION		644 LOUP	1
53560 HULL ST		681 LEE	1
SAN DIEGO CA 92152-5001		681 TALMY	1
		684 LIU	10
NON-DOD ACTIVITIES		7220 WILSON	1
DEFENSE TECHNICAL INFORMATION CTR			
CAMERON STATION			
ALEXANDRIA VA 22304-6145	2		
ATTN W W HO	1		
ROCKWELL INTERNATIONAL SCIENCE CENTER			
1049 CAMINO DOS RIOS			
THOUSAND OAKS CA 91360			