

CONCEPT DESIGN ANALYSIS

CERCLA WASTEWATER TREATMENT PLANT

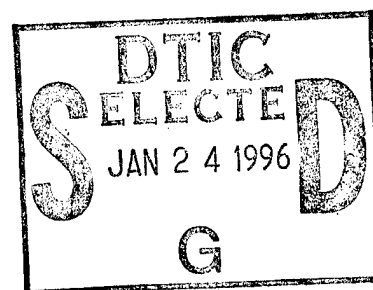

ROCKY MOUNTAIN ARSENAL
COLORADO

JULY 1990

19960119 005



US Army Corps
of Engineers

DISTRIBUTION STATEMENT A

Approved for public release;
Distribution Unlimited

REPORT DOCUMENTATION PAGE

Form Approved
OMB No. 0704-0188

Public reporting burden for this collection of information is estimated to average 1 hour per response, including the time for reviewing instructions, searching existing data sources, gathering and maintaining the data needed, and completing and reviewing the collection of information. Send comments regarding this burden estimate or any other aspect of this collection of information, including suggestions for reducing this burden, to Washington Headquarters Services, Directorate for Information Operations and Reports, 1215 Jefferson Davis Highway, Suite 1204, Arlington, VA 22202-4302, and to the Office of Management and Budget, Paperwork Reduction Project (0704-0188), Washington, DC 20503.

1. AGENCY USE ONLY (Leave blank)	2. REPORT DATE 07/00/90	3. REPORT TYPE AND DATES COVERED
----------------------------------	----------------------------	----------------------------------

4. TITLE AND SUBTITLE CERCLA WASTEWATER TREATMENT PLANT, ROCKY MOUNTAIN ARSENAL, COLORADO	5. FUNDING NUMBERS
--	--------------------

6. AUTHOR(S)	
--------------	--

7. PERFORMING ORGANIZATION NAME(S) AND ADDRESS(ES) ARMY CORPS OF ENGINEERS. OMAHA DISTRICT OMAHA, NE	8. PERFORMING ORGANIZATION REPORT NUMBER 90249R01
--	--

9. SPONSORING/MONITORING AGENCY NAME(S) AND ADDRESS(ES)	10. SPONSORING/MONITORING AGENCY REPORT NUMBER
---	--

11. SUPPLEMENTARY NOTES

12a. DISTRIBUTION/AVAILABILITY STATEMENT APPROVED FOR PUBLIC RELEASE; DISTRIBUTION IS UNLIMITED	12b. DISTRIBUTION CODE
--	------------------------

13. ABSTRACT (Maximum 200 words) THE CERCLA WATER TREATMENT PLANT IS DESIGNED TO TREAT WASTEWATERS GENERATED THROUGH INTERIM ACTIONS, WELL DEVELOPMENT, DECONTAMINATION, AND OTHER ON-GOING REMEDIATION ACTIVITIES. THE SYSTEM IS TO HAVE SUFFICIENT FLEXIBILITY TO ALLOW CUSTOMIZED TREATMENT OF A VARIETY OF CONTAMINANTS. THIS PRELIMINARY DESIGN ANALYSIS REPORT COVERS ALL INTERIOR TREATMENT PROCESSES AND PIPING, AS WELL AS THE EXTERIOR WATER AND SANITARY SEWER. THIS DOCUMENT CONSISTS OF TWO PARTS. PART 1 - CONCEPT DESIGN ANALYSIS. PART 2 - DRAWINGS.
--

14. SUBJECT TERMS PPEND, SPECIFICATIONS, FOUNDATION ANALYSIS, CONCEPT DESIGN ANALYSIS	15. NUMBER OF PAGES
	16. PRICE CODE

17. SECURITY CLASSIFICATION OF REPORT UNCLASSIFIED	18. SECURITY CLASSIFICATION OF THIS PAGE	19. SECURITY CLASSIFICATION OF ABSTRACT	20. LIMITATION OF ABSTRACT
---	--	---	----------------------------

CONCEPT DESIGN ANALYSIS
FOR
CERCLA WASTEWATER TREATMENT PLANT
ROCKY MOUNTAIN ARSENAL, COLORADO

TABLE OF CONTENTS

	<u>PAGE</u>
PART 1 - GENERAL DESCRIPTION	1-1
1. Purpose	1-1
2. Authority & Scope	1-1
3. Criteria	1-1
PART 2 - DESIGN REQUIREMENTS AND PROVISIONS	2-1
1. Civil: Paving, Grading, Drainage and Fencing,	2-1
2. Process Equipment and Piping	2-4
3. Architectural	2-10
4. Structural	2-13
5. Mechanical	2-15
6. Electrical	2-18

APPENDICES

A Foundation Analysis	A-1
B Water Supply and Wastewater Collection Calculations	B-1
C Structural Calculations	C-1
D Electrical Calculations	D-1

Accession For	
NTIS CRA&I	<input checked="" type="checkbox"/>
DTIC TAB	<input type="checkbox"/>
Unannounced	<input type="checkbox"/>
Justification	
By	
Distribution /	
Availability Codes	
Dist	Avail and/or Special
A-1	

Memorandum Decision Documents

PART 1 - GENERAL DESCRIPTION

1. **PURPOSE.** This project is necessary to provide treatment to wastewaters generated through interim actions, well development, decontamination and other pertinent operations. The Rocky Mountain Arsenal is currently without a facility capable of providing this service.

2. **AUTHORITY AND SCOPE.**

2.1. **Authorization.** This project is authorized by Design Directive Number _____ dated _____, 1990.

2.2. **Scope.** This project shall consist of a treatment facility capable of treating a variety of influent wastewaters. The system must be designed with sufficient flexibility to allow customized operation of the treatment plant. The plant shall also have a decontamination facility incorporated within the final design package. The decontamination facility shall be utilized to clean drums, equipment and vehicular traffic.

3. **CRITERIA.**

3.1. Project design based upon design review meetings held on 24 April 1990 and 11 May 1990, and a telephone conversation dated 7 June 1990 concerning placement of the decontamination facility.

3.2. Uniform Building Code.

3.3. National Fire Protection Association (NFPA) and applicable ETL's.

3.4. Architect/Engineer Instruction Manual (AEIM - 14)

3.5. Applicable COE (Omaha District) Guide Specifications.

3.6. Other applicable design criteria as stated in the separate sections of this Design Analysis.

PART 2 - DESIGN REQUIREMENTS AND PROVISIONS

1. CIVIL: GRADING, PAVING, DRAINAGE, AND FENCING.

1.1 DESIGN REFERENCES. The following references were used in preparing the grading, paving, drainage, and fencing design:

1.1.1 Department of the Army and Air Force Technical Manuals.

TM 5-818-2 Pavement Design for Seasonal Frost
88-6, Chap 4 Conditions (Jan 85)

TM 5-820-4 Drainage for Areas Other Than
88-5, Chap 4 Airfields (Oct 83)

TM 5-822-2 General Provisions and Geometric
88-7, Chap 5 Design for Roads, Streets, Walks,
and Open Storage Areas (July 87)

TM 5-822-5 Flexible Pavements for Roads,
88-7, Chap 3 Streets, Walks, and Open Storage
Areas (Oct 80)

1.1.2 Department of the Army Technical Manuals (TM).

5-822-8 Bituminous Pavement, Standard
Practice (Dec 71)

1.1.3 Engineer Manuals (EM).

1110-2-2902 Conduits, Culverts and Pipes
(Mar 69)

1.1.4 U.S. Army Engineer Waterways Experiment Station Technical
Report (TR).

GL-88-2 Life Cycle Cost For Drainage
Structures

1.1.5 NEENAH Foundry Company Publication.

Inlet Gate Capacities

Inlet Gate Capacities for Ponded
Water

1.1.6 Uniform Federal Accessibility Standards (Aug 84)

1.2 GRADING. The following criteria was used to develop site grading.

1.2.1 Crown grade of 2 percent.

- 1.2.2 Minimum desirable gutter grade of 0.8 percent with absolute minimum of 0.5 percent.
- 1.2.3 Desirable minimum transverse parking area grade of 2 percent. Absolute minimum grade of 1.5 percent for flexible pavement and 1 percent for rigid pavement.
- 1.2.4 Maximum desirable parking area grade of 4 percent.
- 1.2.5 Maximum desirable ramp grade of 7 percent. Absolute maximum ramp grade of 10 percent for short distances only.
- 1.2.6 Desirable minimum grade of 5 percent for 10 feet away from building and desirable maximum grade of 10 percent for 10 feet.
- 1.2.7 Minimum grade of 1 percent for overlot grading for cohesionless sandy soils and 2 percent for cohesive soils or turfed areas.
- 1.2.8 Minimum ditch grade of 0.3 percent.
- 1.2.9 Maximum foreslopes of 1V on 4H and backslopes of 1V on 3H.
- 1.2.10 Maximum longitudinal walk grade of 10 percent in freezing climates and 15 percent in nonfreezing climates. Walks that are classified as handicapped accessible shall not exceed 8.333 percent (1:12) slope with 5 feet level landings at 30 feet maximum spacing and at the top and bottom of the slope.
- 1.2.11 Transverse walk grade of 2 percent.

1.3 PAVEMENT DESIGN.

1.3.1 FLEXIBLE PAVEMENT

1.3.1.1 Traffic consists of the following vehicles:

1.3.1.2 Strength Method. (Non-Frost Design)

Class = F
Category = IV
Design Index = 3
CBR = 5
Design Thickness = 13.5 inches

1.3.1.3 Reduced Subgrade Strength Method. (Frost Design)

Design Index = 3
Soil Group = F3
Soil Support Index = 3.5

Design Thickness = 17 inches

1.3.1.4 Limited Subgrade Frost Penetration Method.
(Frost Design)

Design Freezing Index = 1,000 degree-days
Water Content = 11-15 percent
Average Dry Density = 108 pcf
Frost Penetration, a = 43 inches
Surface Course Thickness, p = 3 inches
Computed Base Thickness, (c=a-p) c = 40 inches
Design Base Thickness = 26 inches
Total Design Thickness = 29 inches

1.3.1.5 Recommended Pavement Section.

3-inches Bituminous Surface Course
Bituminous Prime Coat
3-inches Crushed Aggregate Base Course
4-inches Subbase Course
4-inches Granular Filter Course
24-inches Compacted Subgrade (95% maximum

density)

1.4 DRAINAGE. Storm drains and culverts were designed in accordance with AFM 88-5, chapters 1 and 2, TM 5-820-3, TM 5-820-4, and TR GL-88-2.

1.4.1 Design Storm used for the design of storm drains and culverts was 1.5 inches per hour for a ten year frequency.

1.4.2 Infiltration rate for generalized soil classifications was _____ inches per hour.

1.4.3 Minimum Critical Duration of Supply.

1.4.3.1 Turfed Areas = 20 minutes

1.4.3.2 Paved Areas = 10 minutes

1.4.4 Storm Drain and Culvert Pipe. Storm drains and culverts were designed to withstand earth dead loads as well as H-20 or HS-20 highway live loads.

1.4.4.1 Pipe Materials. Based on a minimum 25-year design service life, the following pipe materials were allowed.

1.4.4.1.1 Reinforced Concrete Pipe.

1.4.4.2 Pipe Joints. Non-watertight pipe joints were used since ground water was not present at or above the pipelines and backfill was non-erodible.

1.4.5 Inlet Capacity.

1.4.5.1 Curb Inlets. The capacity of curb inlets along sloping gutters was determined using the method presented in the NEENAH Foundry Company publication entitled "Inlet Grate Capacities" for a NEENAH type R-3335-1 curb plate and box. The capacity of curb inlets in a sump condition was determined using figure 3-4 in AFM 88-5, Chapter 4. Inlets along gutters of roads and streets were sized and spaced to allow water to flood not more than half the lane width away from the gutter. Inlets in parking areas were sized to allow water to pond to the top of the curb where possible.

1.4.5.2 Area Inlets. The capacity of area inlets in a sump condition was determined using the nomograph in the NEENAH Foundry Company publication entitled "Inlet Grate Capacities for Pondered Water" for a NEENAH type R-6118 catch basin frame and grate.

1.5 FENCING. The new FE-5 type chainlink security fence was designed to accommodate this project. The fence fabric was 6 feet high with top rail and bottom reinforcing wire.

1.5.1 Chainlink Fabric was zinc coated 9-gage wire woven in a 2-inch mesh. The fabric was installed with a minimum horizontal tension of 1,000 pounds .

1.5.2 Line Posts were galvanized steel pipe.

1.5.3 Tie Wires were 9-gage galvanized steel wire.

2. PROCESS EQUIPMENT AND PIPING, WATER SERVICE AND WASTEWATER COLLECTION.

2.1 DESIGN REFERENCES. The following references were used in preparing the water supply and wastewater disposal design:

Department of the Army Technical Manuals (TM)

TM 5-813-5 Water Supply, Water Distribution (Jun. 79)

TM 5-813-6 Water Supply for Fire Protection (Jun. 83)

TM 5-814-1 Sanitary and Industrial Wastewater Collection
- Gravity Sewers and Appurtenances (Mar. 85)

TM 5-814-2 Sanitary and Industrial Wastewater Collection
- Pumping Stations and Force Mains (Mar. 85)

TM 5-814-6 Industrial Wastes (Oct. 65)

National Standard Plumbing Code (1983)

Recommended Standards for Sewage Works by the Great
Lakes-Upper Mississippi River Board of State
Sanitary Engineers (1978 Edition).

Recommended Standards for Water Works by the Great
Lakes-Upper Mississippi River Board of State
Sanitary Engineers. (Ten State Standards)

National Fire Protection Association (NFPA) Standard.

13-1983 Sprinkler Systems

291-1983 Hydrants, Testing and Marking

American Water Works Association (AWWA).

No. M17 Inspection, Testing and
Maintenance of Fire Hydrants

601-81 Disinfecting Water Mains

Military Handbook 1008A 31 March 1988

2.2 PURPOSE

2.2.1 Background Information. The CERCLA Water Treatment Plant is designed to treat the water generated through the interim response activities taking place on the Rocky Mountain Arsenal. Water from well development, equipment and vehicle decontamination, analytical testing, process water, condensate water, and water generated through on-going remediation activities will be collected and transported to the CERCLA Plant for treatment. Laboratory testing will be performed on a representative sample of the flow to be treated; based upon the testing results a treatment scenario will be developed. A list of contaminants expected to be encountered at the Arsenal may be found in the Alternative Assessment Document prepared for the Arsenal by the Waterways Experiment Station, Corps of Engineers, dated December 1989.

2.2.2 Scope of Report. This preliminary Design Analysis Report will cover all interior treatment processes and piping, as well as the exterior water and sanitary sewer. The following is a synopsis of the system design:

2.3 General Parameters.

2.3.1 The water treatment plant design is based on a flow of fifteen (15) gpm (21,600 GPD).

2.3.2 A summary of the Design Parameters and plant components is contained in the Design Analysis and materials balance.

2.3.3 Water treatment plant flow is produced through daily remediation activities which occur at the Rocky Mountain Arsenal. All contaminated water produced through well development, decontamination, on-going Interim Response projects, and other pertinent activities will be transported or piped into this plant for treatment and subsequent disposal.

2.3.4 Plant staffing will be two people, eight hours per day, five or seven days per week.

2.3.5 Sampling ports will be located on process units throughout the treatment train. This will allow periodic sampling to occur as the wastewater travels through the system. An overview of specific unit performance will be maintained which will allow fine tuning and optimization of specific unit processes.

2.3.6 Treated effluent will be discharged from the treatment facility to the nearest sanitary sewer collection point. Because of the location/elevation of the CERCLA Treatment Plant, a lift station is necessary to transport the treated effluent and domestic wastewater from the plant to the Arsenal collection system. The new lift station is to be located on the northeast corner of the facility. After entering the new lift station, the domestic wastewater and treated effluent is pumped to another lift station to be located northeast of the existing fire station. The lift station adjacent to the fire station is scheduled to be constructed under the Sanitary Sewer Remediation IRA project.

2.4 Functional and Technical Requirements.

2.4.1 Operation. Manual operation of this facility is expected due to the complexity of the treatment plant. A fully automated system would require considerable maintenance to keep the plant fully operational. For this reason, as well as the complexity and variability of the treatment process (as previously stated), it was determined that manual operation of the system would be pursued to maintain system reliability and flexibility. The following is a synopsis of plant operation:

2.4.2 Tank Storage. Influent enters the plant from one of five covered influent storage tanks. Four of the influent storage tanks are twelve foot diameter - 25,000 gallon tanks, and the fifth is eight ~~feet~~ in diameter with a capacity of 5,400 gallons. Tank material is an action item to be determined during final design. Options to be reviewed include epoxy coated carbon steel, fiber reinforced polyethylene (FRP) tanks or polyethylene tanks. Preliminary discussions with vendors indicate that FRP and polyethylene will not be cost competitive with the epoxy coated carbon steel tanks. At this time, the most likely option will be epoxy coated carbon steel. Tank heaters and/or heat tracing will not be required due to the enclosing of the tanks containing the untreated and treated water. Highland Tank and Manufacturing Company manufactures an epoxy coated carbon steel tank which will meet system requirements, at an estimated cost of \$1.25 per gallon of storage.

2.4.3 Loading and Testing of Process Water. Off-loading to the influent tanks will be achieved through the sump located in the decontamination area. The sump is designed to reduce the amount of solids transported into the influent tanks. The influent will discharge to the top of the influent tanks and will free fall into the tank interior. After off-loading the contaminated material into the influent tanks, laboratory testing will be performed to characterize the contaminated water. As such, sampling ports will be located on all tanks to allow easy access for the collection of the required samples.

Laboratory testing will be performed at either the newly constructed Rocky Mountain Arsenal Laboratory, or will be contracted to a local firm.

2.4.4 Treatment. Based upon the results obtained from the influent testing, a decision will be made concerning the most appropriate method of treatment. The treatment plant will then be configured to allow treatment of the specific batch of contaminated water. In a worst case scenario, where all processes will be utilized in the treatment operation, the following path will be followed by the influent water:

2.4.5 Chemical Precipitation Unit. Water entering the plant will be pumped from a specific influent tank through a skid mounted chemical precipitation unit. Preferentially, the pump selected for this operation will be of the centrifugal design with a steep performance curve capable of handling a variety of piping configurations. This is necessary due to the flexibility inherent to the process design. The chemical precipitation unit consists of a flash mix tank in which appropriate chemicals are added to aid in the settling of specific heavy metals (such as iron, copper, cadmium, etc.) Chemicals to be added include acids and caustics to modify the pH, and polymers to aid in settling. The flash mix tank is followed by a flocculation tank, which provides quiescent conditions to aid in the formation of the floc material. The water is then transferred to an inclined plate clarifier where the flocculated material is allowed to settle and remove heavy metals included in the influent flow. Great Lakes Environmental, Inc. produces a unit compatible with the referenced system requirements. Walker Process also manufactures an acceptable unit process.

2.4.6 Sludge Generation. Sludge generated through operation of the chemical precipitation unit, as well as sludges generated through various process backwash operations, will be routed to a covered sump located near the southwest corner of the facility. The sump will be fitted with a set of pumps, one pump used to transfer the settled solids to a drum, and the other pump used to transfer supernatant back to the headworks of the plant. The sludge transfer pump will be of the diaphragm type, while the supernatant pump, with a variable suction elevation, will be of the centrifugal type. All sludge generated in the facility will be vented through a carbon vessel to remove hazardous emissions. After filling the drum with sludge, the drum will be disposed of through the Arsenal solids handling program.

2.4.7 Pre-Filtration Units. Following treatment by the chemical precipitation unit, the water flows by gravity to a holding tank/pumping reservoir located adjacent to the unit. The water is then pumped from this reservoir (using a centrifugal pump with appropriate head restrictions) through a skid mounted pre-filter system consisting of a dual media, sand/anthracite system designed to filter material greater than 10 to 20 microns in size. Acceptable manufactures of this type of process are not limited. Many manufactures involved in the production of wastewater equipment will be capable of supplying this type of small filtration unit. Culligan International, Kisco Boiler and Engineering Company, and Western Water Management were all contacted regarding the availability of a unit capable of meeting performance requirements. All firms indicated that they had an acceptable unit. Most indicated that to consistently meet the 10 to 20 micron requirement, a multi-media package would normally be used, with a layer of garnet added to aid in filtration. This

information is reflected in the telephone conversations following this synopsis. The initial operating scenario is anticipated to include operation until backwash is initiated through an automatic timer mechanism. As an option, and as an action item for the Arsenal, the system backwash could be initiated through the use of a pressure differential switch, which would activate only when the headloss through the filter meets a predetermined level. Costs associated with the pressure differential switch are higher than the costs associated with the timer switch, which is normally supplied with the units. Backwash rate has been established as approximately 15 gpm/ft², requiring a total of 30 to 40 gpm to backwash the unit.

2.4.8 Granular Activated Carbon. Following removal of this small diameter material, the filtered water is then directed to the granular activated carbon system for the removal of volatile and nonvolatile constituents. The method of operation of the granular activated carbon system shall be in the downflow mode. This will avoid problems associated with the potential generation of fines through system operation. The principal removal mechanisms within the GAC contactor consist of adsorption and physical sedimentation/filtration in the unit. Flexibility is designed into the system to allow operation in series mode, to aid in the removal of those refractory materials not preferentially removed in the initial pass through the unit. After exhaustion of an individual carbon canister, the filtered water will be directed to the next series of two while the exhausted canister is removed and replaced with a fresh unit. A total of three units are provided to allow for maximum flexibility in unit operation. All units shall be skid mounted to aid in the replacement after exhaustion of the media. Provisions to backwash the GAC units were incorporated within the system design. All residues generated through the backwash operation shall be routed to the disposal sump for subsequent treatment and disposal. Carbon Air, Inc. was contacted regarding the availability of a suitable unit. The company spokesman indicated that the unit size presented no problem in terms of availability.

2.4.9 Post-Filtration. The granular activated carbon treated flow (to be denoted as GAC water on the plan sheets) is allowed to flow from the final GAC treatment unit to another holding reservoir located juxtapositional to the last carbon unit. The GAC treated water is then pumped through another skid mounted dual media, sand/anthracite filter to aid in the removal of carbon fines generated through operation of the granular activated carbon treatment system. The pump to be used in this instance shall be similar to the pumps used at the other holding tank locations. A steep performance curve, relating to appropriate head considerations shall be used to optimize performance. As another action item, system operation will be reviewed to determine the necessity for providing an additional filtration system consisting of bag filters following the post-filtration dual media system. This will be dependent upon the requirements dictated by the subsequent, downstream processes.

2.4.10 Activated Alumina Treatment. Water exiting the post filtration system is directed to one of two activated alumina process units. These units are designed to remove elevated levels of arsenic and fluoride through adsorption to the activated alumina. Optimum performance of the activated alumina is achieved by acidifying the influent to the process units to a pH of approximately 5.5 (standard units). This will be achieved through the use of a chemical feed system and static mixer to reduce the pH to the necessary level. This process

system is designed to have the flexibility to use either individual units or series operation. LaRouche Chemicals was contacted regarding use of activated alumina for the removal of arsenic and fluoride. Estimated cost of the activated alumina material is estimated at \$0.75 per pound. Operation of this system occurs in a downflow mode. Flexibility in the system is designed to allow operation of either unit as the primary unit.

2.4.11 Ultraviolet Oxidation Treatment. After exiting the activated alumina (referred to as AA water on the plan sheets), water is directed through the ultraviolet (UV) oxidation system for removal of residual organic material. Process operation consists of the addition of hydrogen peroxide (and/or ozone, as will be discussed) to the influent flow (AA flow in this instance) and directing the flow through a unit where ultraviolet radiation is directed onto the flow, oxidizing residual organic material. Hydrogen peroxide (and ozone) are strong oxidizing agents, and the application of UV light releases the hydroxyl radical (OH-) which in turn oxidizes available organic material. The process is not selective, which dictates an influent flow with very low suspended and dissolved solids concentration. As an action item, the addition of ozone to the influent flow will optimize the removal efficiency experienced in the unit. The vendor carrying this treatment unit indicates a significantly reduced operation and maintenance cost over the unit which has hydrogen peroxide as an additive only. Application of the treatment process utilizing hydrogen peroxide only causes a radical increase in the temperature of the waste flow, with past experience indicating a rise of as much as 70 degrees, depending upon the residence time in the reactor. The high temperature rise in this unit is directly related to the UV light tubes. The vendor carrying the ozone/hydrogen peroxide unit uses a lamp with a lower rated wattage. This prevents the radical increase in temperature (estimated at 2 to 3 degrees Fahrenheit), which also aids in the reduction of hard-to-remove scale forming conditions. Following the UV oxidation system with an air stripper is an effective method to reduce the temperature of the flow, if the hydrogen peroxide-only unit is the preferred unit. If air stripping is not utilized after the UV oxidation system and an increased temperature is not desirable, an alternate heat exchanger must be provided to reduce the temperature of the flow. It is not anticipated that the temperature of the water will cause problems in system operation, therefore no alternate methods to reduce the temperature would be provided. Operating efficiency of the UV Oxidation process is pH dependent, with optimum performance realized at a pH between 5 and 6.5 (standard units). The option to add chemicals to the influent flow will be provided to optimize system operation. Flow exiting the UV oxidation system will be referred to as UV water in the plans. Two commercial manufacturers of UV Oxidation units are currently in the market. ULTROX International and Peroxidation Systems, Inc. were both contacted regarding system operation. Preferentially, I believe that the unit utilizing ozone will provide better treatment and provide a lower life cycle cost than the unit which relies solely upon the hydrogen peroxide for treatment.

Take O.H.
2.4.12 Air Stripper Treatment. After receiving treatment in the UV system, the UV water is directed by gravity to another holding tank/pumping reservoir located in the northwest corner of the facility. This holding tank is closely resembles the configuration use for the other holding tanks in the facility. The UV holding tank is used as the repository for water prior to being treated in the air stripper. One option governing air stripper use includes the

potential to relocate the stripper located in the existing south plants treatment plant to the new facility. This is dependent upon the condition of the air stripper and the flow capabilities of the unit. It is likely that a new stripper, capable of operation at a higher flowrate will be required in the new treatment plant. Air stripper treatment occurs as the air stripper selectively removes volatile organic constituents from the waste flow, primarily based upon the Henry's constant associated with the specific parameter. Air flow requirements also affect system performance. It was felt that the principal function of the air stripping unit in this system would be as a polishing aid. As a consequence, it was determined that vapor phase carbon on the off-gas would not be necessary due to the minimal waste load anticipated from the unit. Subsequent conversations with Rocky Mountain Arsenal program managers indicated that vapor phase carbon on the off-gas would be required as a safety feature. The vapor phase carbon unit will be located adjacent to the stripper unit, and shall be replaced as needed, depending upon exhaustion of the carbon unit. Many manufacturers currently market air strippers for this type of application. Delta Cooling Towers is one manufacturer capable of meeting system requirements. Carbon Air Systems was also contacted regarding this proposed method of operation. In addition to the vapor phase carbon unit, the unit must incorporate an air dryer to prevent premature exhaustion of the carbon canisters. Also, the effluent pump on the air stripper is commonly included as part of the process unit. Following treatment within the air stripper, the treated water is directed to the backwash water tank. This treated water may then be pumped back to the headworks of the plant, or it may be pumped directly to the final effluent storage tanks, located adjacent to the influent tank. Piping to the effluent storage tanks will be labelled as "TW", indicating treated water piping.

2.4.13 Effluent Storage and Backwash. After entering the primary effluent storage tank, currently established as 8,000 gallons and located in the northwest corner of the facility, the treated water may be used in a number of different fashions. The principal use to which the treated water will be devoted to is the backwashing of several of the process units, specifically the granular activated carbon and the dual or multi-media, sand/anthracite and/or garnet filters. All water not used for this application will be diverted to the final effluent storage tanks, located adjacent to the influent storage tanks. The configuration of the final effluent tanks mimics the influent tanks, and has been designed to allow testing of the water prior to disposal in the sanitary sewer system. As indicated, ^{in the drawings (sheet 11)} the disposal point, which in the case of the preliminary design, has been selected as the existing sanitary sewer system. Several other options exist for the final disposal of the treated effluent. These options include total containment, artificial wetland disposal, reuse in the decontamination facility, or disposal at the Basin A/Neck treatment facility. Of these options, the most feasible in terms of engineering economy would be the discharge to the sanitary sewer system. The final disposition of the treated water will be considered as an action item until definitive direction is provided by the user. Within the 35 percent design documents, the option is provided to use treated water as an initial wash in the decontamination portion of the treatment facility. This is shown as a pump and hose bib, with the water supply shown as the 5,400 gallon center tank.

2.4.14 Sludge Storage. Consideration was given to the residues generated through the backwash operations and floor drain discharges. All

need surface of 2-10
should be labeled as TW
& should be analyzed disposed
of that all wastewater
to be labeled

backwash waters are directed to a covered sump located in the northwest corner of the treatment facility. Should it be deemed necessary, chemical feeds will be routed to the sump to aid in the coagulation of suspended material. Decanted supernatant is routed to the headworks of the facility for further treatment. As previously indicated, all sludge generated within the treatment plant sump will be evacuated from the sludge sump using a diaphragm pump. The sludge will be pumped to a structure located in the southwest corner, adjacent to the motor control center. The structure will be designed to house the sludge material and a vapor phase activated carbon unit to filter the off-gases.

2.5 Decontamination Facility.

2.5.1 Siting and Operation. The decontamination facility, originally sited on the east side of "D" Street due to Arsenal directive, was subsequently relocated to the west side of "D" Street due to the proximity of contaminated soil. As a result, it was deemed advisable to incorporate the facility into the CERCLA Water Treatment Plant. A substantial cost savings was realized through incorporation of this modification, since the change negated the requirement for a separate structure. The decontamination facility has been designed to operate on the west side of the treatment plant. All water generated during decontamination operations is directed to a floor drain and sump, which subsequently pumps the potentially contaminated water to the influent tanks for future treatment. The sump in the decontamination area is fitted with a weir structure to prevent the carry over of solids into the influent tanks. Following a period of operation, the sump is manually cleaned with the collected soil and debris disposed of in an acceptable manner. Operation of the decontamination facility will consist of the use of hose bibs located along the interior wall of the facility. One of the hose bibs will be clearly marked as using "recycled" water, and will be used for preliminary wash activities only, to be followed by a final rinse. *if deemed appropriate*

2.5.2 Facility Layout. In addition to the wash units located in the decontamination area, the area is subdivided into four process units. These units have been individually labelled as the "Equipment Storage and Utilities" area, to be used to store decontaminated equipment. Adjacent to the "Equipment Storage and Utilities" unit is the "Noncontaminated Drum Storage" unit. As the title indicates, this unit is reserved for drums fully decontaminated, through operations which occur in this facility. Fittingly enough, juxtapositional to the "Noncontaminated Drum Storage" unit is the "Drum and Equipment Decontamination" unit, which is utilized to decontaminate material contaminated during Arsenal cleanup activities. The final unit in the decontamination bay has been labelled as the "Contaminated Drum Storage" area, to be used to store drums not yet decontaminated through subsequent cleaning steps. Contaminated drums and equipment will be routed through the facility for complete decontamination prior to reuse.

2.5.3 Wash Water. As previously indicated in ~~paragraph~~ 5.1 in an attempt to minimize water usage, treated plant water will be used as a "preliminary wash" to remove heavy particulates from the vehicles. Any water not used in vehicle decontamination will be routed to the sanitary sewer for subsequent disposal.

may

paragraphs 2.4-134

2.6 Fire Protection Water Supply.

2.6.1 Existing System. The existing system near the proposed facility consists of an eight inch and four inch potable water lines located on the east side of "D" Street, and a nonpotable twelve inch cast iron line located on the west side of "D" Street. No static or residual pressures were available in this area for this phase of the design. As an action item, pressures must be obtained to verify the adequacy of the system.

2.6.2 Proposed System Improvements. Both interior and exterior fire protection were provided to the treatment facility. In accordance with Mil. Hdbk. 1008A, the facility was classified as Type II-N Construction, with a hazard classification of Ordinary, Group 2. It was determined that the process area, with approximately 3,150 square feet, would be sprinklered with a wet pipe sprinkler system. The remainder of the facility would be protected through exterior fire protection. As indicated, Military Handbook 1008A stipulated that a minimum of 1,200 gallons per minute (gpm) would be required for exterior protection (for a minimum of two hours) and 690 gpm would be required for interior sprinkler system. Protection to the facility, at the flows indicated in the former paragraph, is provided through the use of a six inch firewater line off of the twelve inch nonpotable line. This service is necessary to provide the required 690 gpm interior sprinkler flow. Two hydrant leads are also tapped into the twelve inch line to provide the required 1,200 gpm exterior flow. Military Handbook 1008A indicates that no more than 750 gpm are to be withdrawn from any one hydrant.

2.7 Domestic Water Supply.

2.7.1 System Improvements. Domestic water service was provided to the CERCLA Water Treatment Plant through the use of a two inch water line, tapped off of the existing eight inch potable water line located on the east side of "D" Street. The peak demand for the facility was calculated pursuant to the National Standard Plumbing Code (NSPC) fixture unit method. The fixture unit count was established as 12 F.U., which equates to a flow of 28.6 gpm.

2.8 Sanitary Waste Collection.

2.8.1 Existing System. The existing sanitary collection is located southeast of the proposed building location. The collection point consists of a lift station which subsequently transports the wastewater west to the main lateral. The tie-in lift station is to be constructed under the Sewer Remediation Contract, which will provide service to the fire station and south plants area.

2.8.2 Proposed System Improvements. Because of grade differences, a lift station will be necessary to transport the wastewater from the CERCLA plant to the existing lift station. In this instance, wastewater is defined as treated plant water and conventional wastewater generated onsite. Approximately 510 lineal feet of two inch forcemain will be required to transport the wastewater from the new lift station to its ultimate discharge point. Two - six inch service lines will be constructed to transport wastewater to the new lift station. Total line length is estimated at \pm 80 feet.

3. ARCHITECTURAL.

3.1 GENERAL PARAMETERS.

3.1.1 Purpose and functions of the facility. The facility has four functional subdivisions; house mechanical equipment required for the project, tank storage, decontamination and unloading, and to provide an office area for the people who will operate the facility. The office area will also have a simple viewing gallery for visitors.

3.1.2 Desired Image. The desired image of the facility is of an industrial nature, with the larger mass relaying the concept of adaptable volume to the exterior. The buildings massing and scale is directly related to the function within. The building is given more of a human (though still industrial) scale at the entrance to the office by means of a cantilevered canopy over the stoop. Three elevation schemes were provided, to allow the using agency to chose a direction for aesthetics. One scheme emphasizes horizontal lines, while another emphasizes a very functional, vertical direction. All three elevation schemes reflect functional needs from within. The fenestration adapts the very functional elements of windows, doors, and louvers to create the schematic styles. A human scaled and functional c.m.u. wainscot is indicated on scheme #1. This wainscot could be adapted on the other schemes. The roof pitch was a functional choice for the chosen standing seam metal roof as well as dealing with the volumetric requirements within. Structural bay sizes and configuration were dictated by the size and number of storage tanks. The result is a very compact, efficient, and structurally conflict-free, facility.

3.1.3 Number of personnel to use the facility. The expected occupancy of the building is only 2-4 people for an eight hour shift each day. Tours may be expected infrequently and under controlled conditions.

3.1.4 Type of activities, equipment, and vehicles involved. The activities within this facility will be exclusively, administration, decontamination, and operation of the equipment required to perform the functions as set forth in the environmental portion of this design analysis. The equipment required to perform these functions will include tanks, sumps, pumps, manifolds, extensive piping and drainage, and associated items. The only vehicles which will be entering the building are forklifts used only on occasion to move or replace equipment, tank trucks unloading contaminated water, and other smaller vehicles which may need to be decontaminated. Verify the size of the overhead ~~doors~~ ^{Commed} at the unloading/decontamination bay. These doors should handle most trucks. The configuration and size of the decontamination bays were adapted from a similar project and attached to the unloading portion of the building. This eliminated the need for separate building and the drive-thru serves two purposes.

3.1.5 Anticipated life of the facility. The requirement for the functions of this facility is for an unknown period, and as it may be for a shorter duration, the building will be constructed as semi-permanent.

3.1.6 Method of construction. The basis of the building is a rigid frame pre-engineered shell. This system was chosen for economy,

adaptability, quick assembly, expendability, and appearance. Within the shell of the building, a portion was partitioned off to form an office, viewing gallery, toilet, closet, and storage rooms. The walls within this area are of gypsum wallboard on steel studs., with the walls in the chemical storage and treatment rooms being covered with metal panels to resist abuse and water. The lower portions of the walls in the treatment area and tank storage will have a c.m.u. wainscot. The exterior walls in these areas, will have a metal liner panel for the interior finish. The walls separating the decontamination bays are 8-inch c.m.u., to resist water and physical abuse. The office will have an acoustical tile ceiling, with the adjacent toilet and closet having gypsum wallboard ceilings. Above the partitioned rooms is a mechanical mezzanine constructed of a composite deck over steel joists. The floor through out most of the facility is concrete. The office, viewing gallery, toilets and storage will be V.C.T..

3.1.6.1 The roof of the building (and the ceiling in the treatment, tank storage, decontamination, and mezzanine areas) will be constructed of metal roofing over purlins with a double layer system of batt insulation between and under. The finished interior face will be a white, heavy vapor barrier, retained in place with metal straps.

3.1.6.2 The exterior walls of the building will be factory insulated metal sandwich panels. Panels are rigid foam insulated with metal finished faces on both sides. The interior metal face provides the vapor barrier and finish.

3.1.6.3 95% of the windows indicated on the elevations are insulated fiberglass panel units. These were chosen because of the ability to let natural light into the facility while maintaining high U-values, resist chemical/moisture attack and their ability to cost effectively enhance industrial buildings.

3.1.6.4 The architectural louvers indicated on the elevations are highly functional, and were used to enhance the large elevations. The louver shapes soften the elevations while tying the various fenestration elements together.

3.2 FUNCTIONAL AND TECHNICAL REQUIREMENTS.

3.2.1 Functional areas. The treatment area was designed to be as adaptable as possible, with a clear space down the center for access to the equipment on each side by forklifts or people. The outside walls will be unobstructed to provide clear space for piping as required.

3.2.2 Energy conservation. The only conventional windows in the facility will be in the office. A canopy to block the sun during the summer season is provided at the main entry. The building is also zoned into separated areas because of the various heating and cooling requirements. This zoning reduces the heating loads tremendously and maintains human comfort to areas which will be regularly occupied. The insulated fiberglass window panels will efficiently enhance the lighting of the equipment and will provide enough natural

light should the power go out. The walls and roof have been insulated to meet current energy requirements.

3.2.3 Sound and vibration control. Since the floor between the mezzanine and office will be composite, it will absorb a substantial portion of the energy created by the equipment above.

3.2.4 Barrier-free design. This facility will comply with the standards set forth in the Uniform Federal Accessibility Standards to provide access by the physically handicapped. The equipment, drains, curbs, etc. may restrict travel in the tank storage and process areas, but the physically handicapped are not expected in these areas.

3.3 CALCULATIONS.

3.3.1 Square Footage. The mezzanine is not included in these calculations as it is a low headroom area.

<u>Room Number</u>	<u>Room Name</u>	<u>Square Footage</u>
101	Viewing Gallery	264
102	Office	208
103	Storage	42
104	Toilet	42
105	Mechanical/Electrical	64
106	Chemical Storage	56
107	Process Area	2,200
108	Tank Storage	3,150
109	Vehicle Unloading/Decon.	1,470
110	Con. Drum Storage	391
111	Drum & Equip. Decon.	391
112	Drum Storage	391
113	Equip. Storage & Utilities	391
114	Chemical Storage	63
	Total Net Square Footage	9,123
	Total Gross Square Footage	9,450

3.4 R-VALUE OF ROOF.

Outside Air Film	0.17
Metal Roofing	--
Batt Insulation	32.00
Vapor Barrier	--
Inside Air Film	<u>0.61</u>

Total R = 32.78 (U = 0.03)

3.5 R-VALUE OF EXTERIOR WALL @ TREATMENT.

Outside Air Film	0.17
Metal Panel	--
Foam Insulation Core	15.38
Metal Liner Panel	--
Inside Air Film	<u>0.68</u>

Total R = 16.23 (U = 0.06)

4. STRUCTURAL.

4.1 PROJECT DESCRIPTION (General). The Water Treatment Plant is 110' x 70' Building in plan, and is an original design. The building consists of three units. The Tank Storage in the middle of the building has an eave height of 35', and a gable roof slope of 4V to 12H. On one side of the Tank Storage Unit is the Process Area Unit with eave height of 14', and a mono roof slope of 4V to 12H. On the other side of the Tank Storage Unit is the Vehicle Unloading Unit with eave height of 14', and a mono roof slope of 4V to 12H.

4.1.1 Roof gravity and lateral loads will be transferred through the Roof Framing System to the steel columns. The columns will be rigidly fixed at the roof level and pinned at the foundation.

4.1.2 Structural Framing System. Structural Framing System consists of 5-Rigid Frame Structures, Purlins and Rigid X-Bracing for lateral loads.

4.1.3 Floor Slabs. Floor Slabs will be structural slabs-on-grade (8" thick min.) reinforced in each direction. In the Tank Storage Area, the slab will be thickened to support the Storage Tanks. All floor slabs will be free floating slabs.

4.1.4 Foundations will consist of pedestals on spread footings to support the structural steel columns. Between the pedestals the cast-in-place grade beams will be installed with the reinforcement continuing through the pedestals. The spread footings and the grade beams will bear a minimum of 3'-6" below the finished grade for frost consideration.

4.2 DESIGN CRITERIA. The following references will be used in preparing the Final Structural Design:

4.2.1 Department of the Army, the Navy, and the Air Force Technical Manuals.

4.2.1.1 TM 5-809-1 Load Assumptions for Buildings.

4.2.1.2 TM 5-809-2 Concrete Structural Design for Buildings (Aug 1984)

4.2.1.3 TM 5-809-10 Seismic Design for Buildings (Feb 1982)

4.2.1.4 TM 5-809-12 Concrete Floor Slabs on Grade Subjected to Heavy Loads

4.2.2 American Concrete Institute (ACI) Publications.

4.2.2.1 ACI 318-89/318R-89 Building Code Requirements and Commentary for Reinforced Concrete.

4.2.3 American Institute of Steel Construction (AISC) Publication.

4.2.3.1 Manual of Steel Construction (9th Edition)

4.3 DESIGN LOADINGS.

4.3.1 Roof Live Load. The roof snow load was determined in accordance with (TM 5-809-1). Ground snow load used in determining the roof snow load is 15 psf. Other factors used in design are: C_e (Exposure Factor) = 1.0, C_t (Thermal Factor) = 1.1, I (Snow Load Importance Factor) = 1.0. Drift loads were taken into consideration. A minimum roof snow load of 30 psf was used based upon local practice.

4.3.2 Floor Live Loads. 300 psf or equipment load will be used for design of slabs-on-grade.

4.3.3 Wind Loads. External design wind pressures were computed in accordance with (TM 5-809-1) using a 50-year basic wind speed of 85 mph. Other factors used in determining the wind pressures are: I (Wind Load Importance Factor) = 1.0, $G C_{pi}$ (Internal Pressure Coefficient and Gust Response Factor Product) = ± 0.25 . A 5 psf pressure will be used on all interior partitions in accordance with (TM 5-809-1).

4.3.4 Seismic Loads (TM 5-809-10). This project is in Seismic Zone 1.

4.3.4.1 Z-Coefficient = $3/16$, I (occupancy co-efficient) = 1.0, K = 1.33, C_S < 0.14.

4.3.5 Foundation Design Criteria. The following parameters were used for design of the foundation:

4.3.5.1 Design frost depth = 3.5 ft. below finish grade (Heated Building).

4.3.5.2 Allowable excess soil bearing pressure = 2,000 psf.

4.4 MATERIAL STRENGTHS. Structural materials of the strengths indicated were used in the design.

4.4.1 Concrete: f'_c = 3,000 psi minimum compressive strength at 28 days except Structural Floor Slabs in Vehicle Unloading, Tank Storage, and the Process Area where flexural strength will be minimum 650 psi at 28 days.

4.4.2 Reinforcing Steel: f_y = 60,000 psi, Grade 60.

4.4.3 Structural Steel: Fy = 36,000 psi, ASTM A36.

4.5 SPECIFICATIONS: The following Corps of Engineers Guide Specifications will be used on this project.

4.5.1 Section 02201 Excavation, Filling, and Backfilling for Buildings.

4.5.2 Section 03300 Concrete (For Building Construction).

4.5.3 Section 05500 Miscellaneous Metal.

4.5.4 Section 05311 Steel Roof Deck.

4.5.5 Section 07416 Standing Seam Metal Roofing System.

4.5.6 Section 13121 Metal Buildings.

5. MECHANICAL.

5.1 GENERAL. The mechanical design for the CERCLA Water Treatment Plant, Rocky Mountain Arsenal, CO will include a complete energy efficient environmental control system and plumbing system.

5.2 APPLICABLE CRITERIA.

TM-5-810-1	Technical Manual, Mechanical Design, Heating, Ventilating and Air Conditioning (Aug 1983)
TM-5-810-5	Plumbing, Chapter 4 (Nov 1982)
ASHRAE	Guide and Data Books
MIL-HDBK-1008	Fire Protection for Facilities, Engineering, Design, and Construction, dated 30 April 1985
TM 5-785	Engineering Weather Data, dated July 1987
National Plumbing Code	

5.3 DESIGN REQUIREMENTS.

5.3.1 Design Criteria:

<u>Elevation:</u>	5184 feet
<u>Latitude:</u>	39 50'N
<u>Longitude:</u>	104 53'W
<u>Heating Degree Days:</u>	6016
<u>Cooling Degree Days:</u>	625
<u>Wind:</u>	8 knots S

5.3.2 Design Temperatures.

5.3.2.1 Winter:
Outside: - 5° F Ventilation
1° F Envelope
Inside: 70° F General

5.3.2.2 Summer:
Outside: 91° F DB
89° F WB
Inside: 75° F General
@ 50% RH Office

5.3.2.3 Personnel: Six (6) people assumed.

5.3.2.4 Hours of Operation: 0700-1700, 5 days per week
assumed.

5.3.2.5 "U" Values:
Roof: 0.03 Btuh/F - SF
Walls (Net): 0.07 Btuh/F - SF
Walls (Gross): 0.10 Btuh/F - SF

5.3.2.6 Ventilation Rates:

5.3.2.6.1 General:
Summer: 20 cfm/person office
Winter: 20 cfm/person office

5.3.2.6.2 Toilets: 2.0 cfm per S.F. exhaust.

5.3.2.6.3 Mechanical/Electrical, Chemical
Storage, Process and Tank Storage. 3.0 cfm per sq ft above 85° F.

5.3.3 PLUMBING. The plumbing design provided domestic hot and cold water to plumbing fixtures. A floor drain was located in the Mechanical Room and restroom. Domestic hot water supply temperature was limited to 100 degrees F. Domestic hot water was provided by gas-fired hot water heater to provide year round service. Two (2) emergency eye-wash and showers will be provided in process area. Trench were in Truck drive-through, tank storage and process area only. FRP coated cast iron soil pipe will be used underground.

5.3.4 HVAC SYSTEM:

5.3.4.1 Heating Systems. Heating and air conditioning for the Office was supplied by a single zone packaged air handling unit with a direct expansion cooling coil, a heating coil, and air filter. The process area is heated by gas-fired unit heaters. The tank storage area is heated by gas-fired unit heaters. The Chemical storage and the decontamination bays and Mechanical/Electrical rooms are also served by gas-fired unit heaters.

5.3.5 VENTILATION. Outside air was required for the building's restroom. Makeup air for the toilet exhausts was introduced into the packaged unit. This makeup air provided sufficient ventilation air for office area

ventilation prior to being exhausted through the toilet room exhaust system. Summer ventilation of process area will be provided by motorized louvers and supply fans.

5.3.6 THE OFFICE TEMPERATURE CONTROL SYSTEM was provided with occupied-unoccupied cycles. These cycles were automatically controlled by a 7-day time clock. For winter operation, the unoccupied cycle provided for night temperature setback, closing the outside air and relief air dampers and de-energizing the toilet room exhaust fan. Space temperature (setback to 55 degrees F) was maintained by cycling the supply fan. For summer operation, the unoccupied cycle de-energized the packaged unit and toilet room exhaust fan at night.

5.3.7 POLLUTION CONTROL:

5.3.7.1 Heating System. The heating system did not involve any air pollution sources.

5.3.7.2 Cooling System. Heat rejected to the air by the packaged air conditioner was not considered a pollutant.

5.3.7.3 Exhaust Systems. The toilet room exhaust system was not considered a pollutant because of the amount of dilution.

5.3.8 ENERGY CONSERVATION SYSTEMS. The following systems and/specials were provided in this facility to conserve energy.

5.3.8.1 The domestic water temperature was limited to 100° F.

5.3.8.2 The Building envelop was designed for a minimum heat gain and heat loss with wall $U = 0.07$ and roof $U = 0.03$.

5.3.9 FIRE PROTECTION. The Facility will be automatically sprinklered,

5.3.10 QUESTIONS:

Provide existing 2" and 4" gas line pressures.

6. ELECTRICAL.

6.1 GENERAL. This design will be based on, but not limited to the following publications, codes, specifications, etc.

6.1.1 National Electrical Code NFPA No. 70. 1990

6.1.2 Life Safety Code NFPA No. 101. 1988

6.1.3 National Electrical Safety Code (ANSI) C2-1990.

6.1.4 Omaha District Architect Engineer Instruction Manual AEIM 14.

6.1.5 NFPA No. 78-1986, Lightning Protection Code.

6.1.6 Other appropriate references.

6.2 SCOPE. This design will generally consist of the following details:

6.2.1 Interior Electrical.

6.2.1.1 Illumination. Illumination will be as follows:

LIGHTING FIXTURE SCHEDULE

<u>ROOM NUMBER/NAME</u>	<u>DESIGN FOOT-CANDLES</u>	<u>FIXTURE TYPE</u>
Office	50	206C
Bathroom	20	206A
Storage Room	15	206A
Chem. Storage Room	15	206A
Mech/Elec Room	15	206A
Viewing Gallery	15	206A
Process Area	30	302B
Sludge Storage	15	206A
Tank Storage	15	302B
Unloading/Decon. Area	30	302B
Cont. Drum Storage	15	233
Drum & Equip. Decon.	15	233
Noncont. Drum Storage	15	233
Equipment Storage	15	233

6.2.1.1.1 The lighting system consists of fluorescent type lighting fixtures in the personnel area and the sludge storage room, and high pressure sodium type lighting fixtures suitable for wet locations in the industrial area and on the building exterior. The Low Bay type 302B fixtures shall consist of an optical assembly which is enclosed, gasketed, and locked to the ballast housing by a positive vibration-proof means.

6.2.1.1.2 The lighting fixture calculations will be performed by the Elite Software Development, Inc. Lighting Program.

6.2.1.1.3 Egress illumination will be provided over exterior entrance doors and near the doorway between the industrial area and the office. A minimum of 1 foot-candles shall be provided in all passageways leading to an exit. Automatic failover to the battery will be provided upon loss of power. The egress lighting shall be provided by type 603 emergency battery pack units with two 6 volt floodlights.

6.2.1.1.4 Exit sign illumination will be provided over exterior entrance doors and over the door from the industrial area to the office via type 604A3 exit lights. Each exit sign lighting fixture shall be self-contained type with emergency battery. The source of power for the exit lights shall be from the lighting and distribution panel on a separate circuit.

6.2.1.2 Raceway System. The raceway system will be as follows:

6.2.1.2.1 Intermediate Metal Conduit (IMC). IMC type conduits will be used for the industrial areas.

6.2.1.2.2 Electric Metallic Tubing (EMT). EMT will be used within the personnel areas not exposed to damp or wet locations.

6.2.1.2.3 Rigid Nonmetallic Conduit (Plastic). Plastic conduit will be utilized for below slab-on grade.

6.2.1.3 Conductors. Conductor design will be based on copper.

6.2.1.3.1 Conductor identification in multiphase systems serving single-phase loads shall be color coded. The color of the insulation of the ungrounded conductors of different voltage systems shall be as follows:

120/208 volt, 3-phase: red, black, and blue;
277/480 volt, 3-phase: yellow, brown, and orange.

6.2.1.3.2 Conductor design will be based on the 60 degree C, copper ampacity column on table 310-16 of the National Electrical Code (NFPA 70) 1990 for #1 AWG conductors and smaller. Conductor design will be based on the 75 degree C, copper ampacity column on table 310-16 of the National Electrical Code (NFPA 70) 1990 for #1/0 AWG conductors and larger.

6.2.1.4 Receptacles. Receptacles will be as follows:

6.2.1.4.1 Grounding type 15 Ampere, 125 volt, three-wire receptacles will be provided in the administrative areas of the building.

6.2.1.4.2 A ground fault (GFI) type 15 ampere, 125 volt, three-wire receptacle will be provided in the restroom.

6.2.1.4.3 Weatherproof type 15 ampere, 125 volt, three-wire receptacles will be provided in the industrial areas.

6.2.1.5 Wall Switches. Wall switches will be rated 120 volt, 15 ampere.

6.2.1.6 Telephone System Prewiring.

6.2.1.6.1 Telephone outlets, conduits and wiring will be provided. The main telephone board will be located in the electrical room. The building will have telephone outlets prewired to type 66MI-50 terminal blocks on the telephone backboard. A telephone jack will be provided in the office area with two remote bells, located in the process area and the vehical unloading area. The telephone outlet will be mounted 18 inches A.F.F.. All telephone instruments will be provided by others. A 4 inch conduit from the electrical room shall extend 6 feet from the exterior building wall. The stubbed out conduit shall be 4inches A.F.F. and 36 inches below grade, capped and marked on grade.

6.2.1.7 Service Equipment and Disconnecting Means. Service equipment and disconnecting means shall be of the circuit breaker type.

6.2.1.8 Panelboards. The lighting and distribution panelboard will be of the circuit breaker type, 3 phase, 120/208 volt. It will be located in the motor control center.

6.2.1.9 Motors, Motor Control, and Control Center.

6.2.1.9.1 Motors shall be controlled from the motor control center.

6.2.1.9.2 The Motor Control Center shall consist of combination type starters and feeder circuit breakers, and will provide centralized power distribution and control for the various process drives. In addition, the control center will also contain the lighting transformer and lighting distribution panel.

6.2.1.10 Dry Type Transformers. Dry-type transformers will be provided to step down voltage from three phase, 277/480 volts to three phase, 120/208 volts for use in the lighting and distribution panel.

6.2.1.11 Ground Fault Circuit Interrupters. Ground Fault Circuit Interrupters will be provided as follows:

6.2.1.11.1 Receptacle in toilets.

6.2.1.11.2 Receptacles in wet locations.

6.2.2 Exterior Electrical.

6.2.2.1 Distribution System.

6.2.2.1.1 The distribution system will consist of a 277/480 volt, 3-phase, 60 hertz grounded wye secondary service from the 13.8 KV, 3-phase, delta primary system. The primary service shall extend underground from the pole to a pad mounted three phase transformer. The secondary service will extend underground from the transformer to the motor control center.

6.2.2.2 Exterior Building Lighting.

6.2.2.2.1 A photoelectric cell located on the north side of the facility shall control the exterior building lighting.

6.2.2.2.2 The exterior building lighting shall be high pressure sodium type 502C.

6.2.2.3 Lightning Protection and Grounding.

6.2.2.3.1 Incoming power and communications lines shall have appropriate lightning (surge) arrester protection.

6.2.2.3.2 The facility shall be grounded via a #4/0 stranded copper ground lead attached to a 10' long ground rod. The ground lead shall be connected to the structure of the building and to the motor control center.

6.3 GUIDE SPECIFICATIONS.

Division 16

16402

16415

Electrical

Electrical Distribution System
Underground.

Electrical Work Interior.

6.4 ACTION ITEMS.

6.4.1 Who is to provide the computer for recording keeping. Is this to be included in the specifications for this job?

6.4.2 What is required for roadway lighting and/or parking lot lighting for the site?

6.4.3 Is this facility to have a fire detection system throughout the entire facility or just in the office and viewing gallery areas?

ATTACHMENT A
FOUNDATION ANALYSIS

PRELIMINARY FOUNDATION ANALYSIS
CERCLA WASTEWATER TREATMENT PLANT
ROCKY MOUNTAIN ARSENAL, COLORADO

1. SCOPE.

This report presents preliminary foundation design information for the proposed CERCLA Wastewater Treatment Plant at Rocky Mountain Arsenal, Colorado. The scope of this study was: (1) Evaluate the engineering properties of subsoils based on previous soil borings drilled in the vicinity of the project site, and (2) Recommend types and depths of foundation elements along with other measures pertinent to foundation design and construction.

2. proposed construction.

The wastewater treatment facility construction will include a single story, pre-engineered metal structure approximately 30'x50' with a 12-15' eave height and five 20,000 gallon aboveground metal storage tanks. The structure will house wastewater treatment equipment and operations.

3. SUBSURFACE INVESTIGATION.

Now new field work was performed for this preliminary study. Subsoil information and laboratory data from two area borings were used as the basis for the following preliminary recommendations. The logs of borings and their relationship to the project site is shown on the enclosed attachments. These logs present field measurements of Standard Penetration Test "N" values, location of ground water, bedrock and description of soil stratigraphy, supplemented by laboratory determinations of moisture content and soil classification. Site-specific subsurface information will be presented at final design.

4. FOUNDATION CONDITIONS.

The site overburden soils generally consist of loose to medium dense alluvial silty and clayey sand (SM & SC), that is interspersed with sandy clay (CL) layers three to five-feet-thick. Based on Standard Penetration Tests ("N" values) these soils are generally very loose to medium dense sands and medium stiff clays. Weathered bedrock exists at a depth of about 19 feet below the ground surface and unweathered bedrock is present at about 24 feet. The groundwater level was encountered at a depth of approximately 11-12.5 feet below the ground surface. However, the groundwater level can be expected to fluctuate appreciably at difference seasons of the year.

5. PRELIMINARY DESIGN RECOMMENDATIONS. The following recommendations are considered suitable for preliminary foundation design:

5.1. Type and Depth of Foundation System. Conventional continuous and isolated shallow foundations may be used to support the proposed structures. The footings should bear a minimum of 3.5 feet below finished grade for frost considerations.

5.2. Allowable Excess Soil Bearing Capacity. An allowable excess soil bearing capacity of 2,000 psf has been successfully used to design the foundation of structures in the vicinity and is recommended for the CERCLA Wastewater Treatment Facilities. If a higher allowable bearing value is required, the material below the footings may be overexcavated and replaced with a compacted fill. The previous foundation recommendations in the general area indicated that the allowable soil bearing value can be increased to 3,000 psf if compacted fill is placed to a depth of 4 feet beneath the footings. Site specific information obtained for final design purposes will be required to verify this alteration.

5.3. Pavement Design. The in-situ subgrade soils generally have a frost design classification of F3 in accordance with TM5-818-2 for pavement design purposes. Flexible pavement design should use a CBR value of 5 for subgrades compacted to 95 percent of ASTM D 1557 maximum density. ~~If~~ rigid pavement design does not consider frost conditions, a subgrade "K" value of 125 lbs/cubic inch can be used for design. If frost conditions are considered in design of rigid pavements, a subgrade "L" value should be selected in accordance with Fig. 20 of TM5-818-2.

5.4. Corrosion Potential. Representative resistivity tests in the area indicate the soils generally have a mild to moderate corrosion potential.

Proposed CERCLA Wastewater Treatment Plant Site

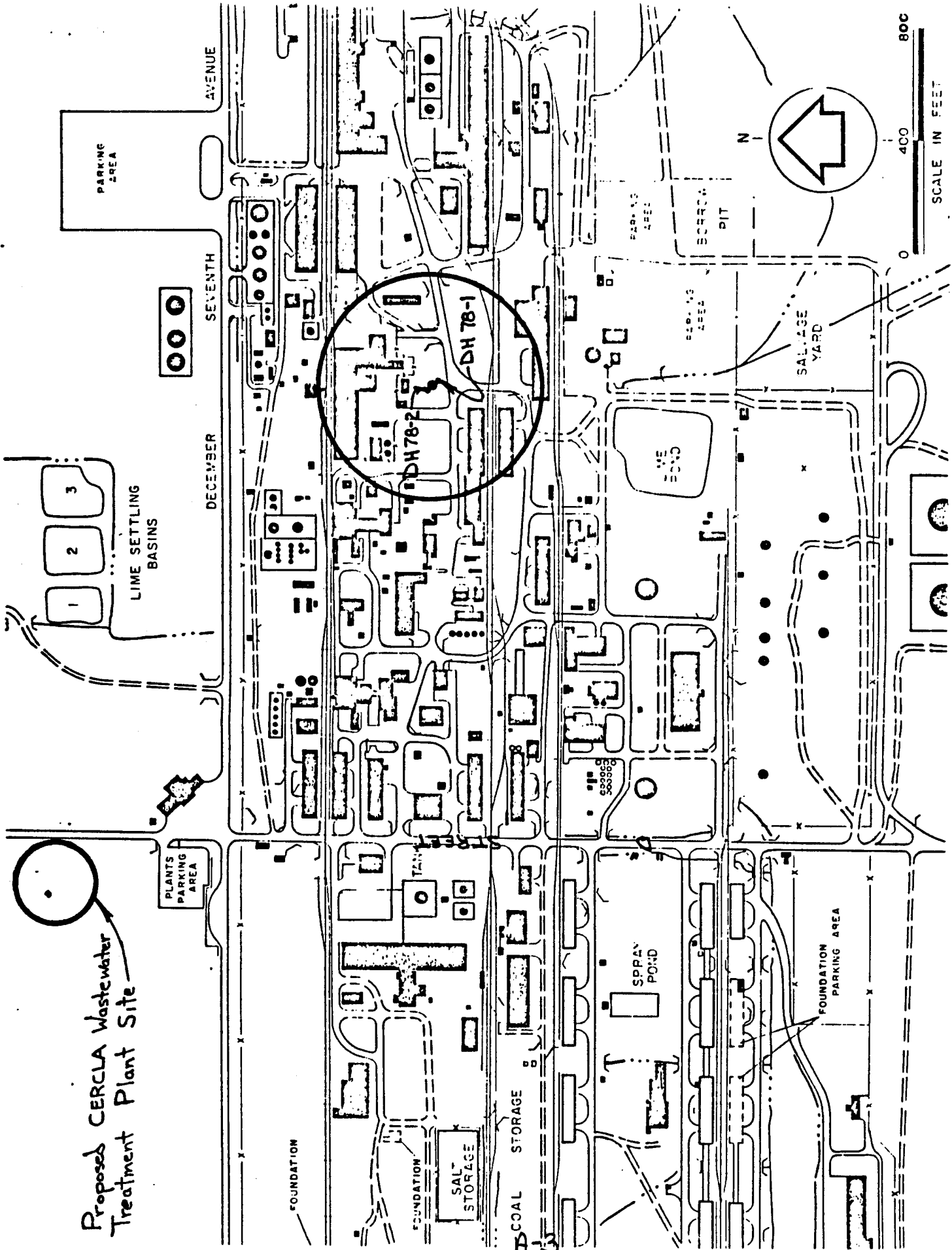

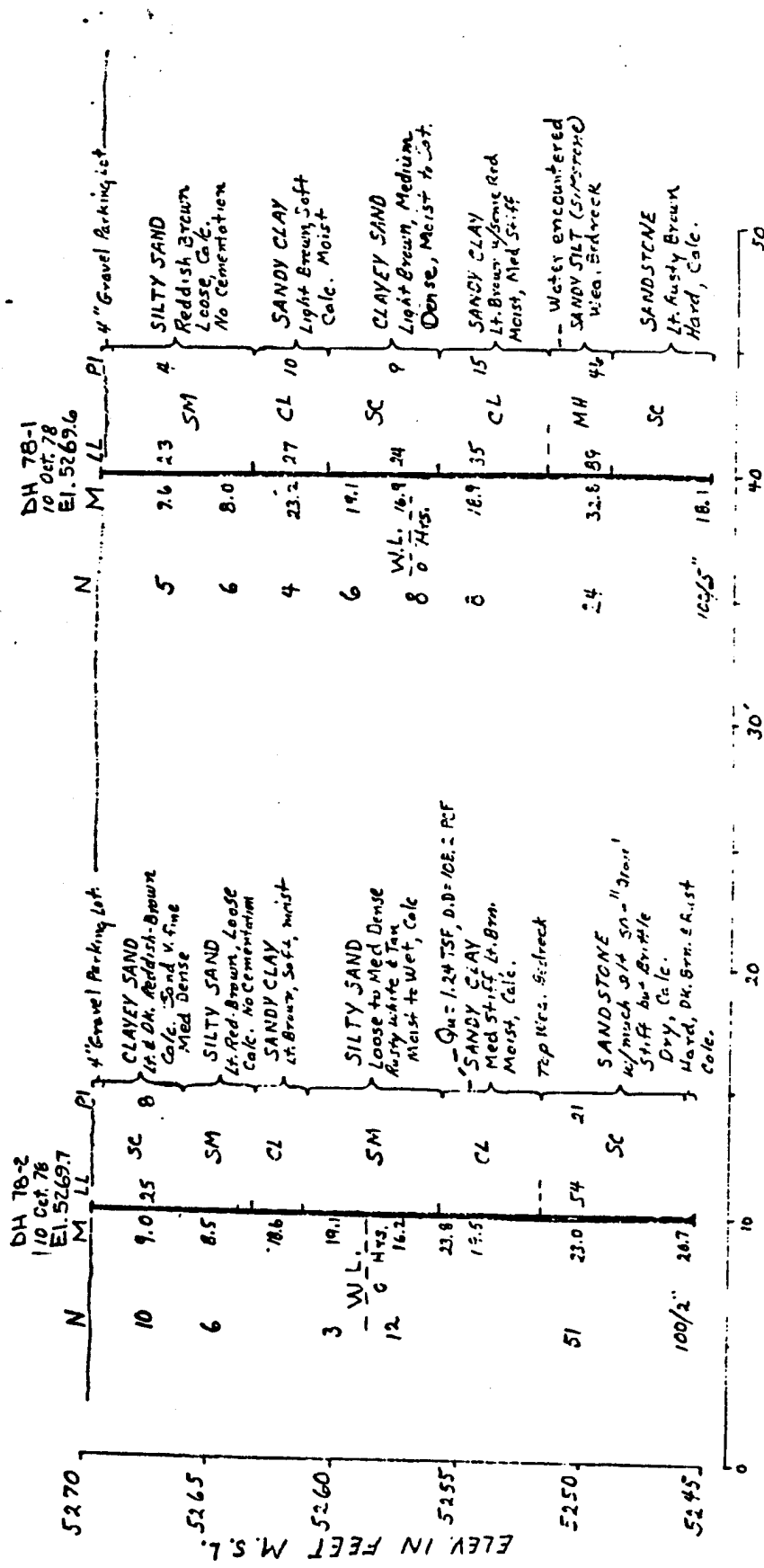

BORING LEGEND

- DH Drill hole number and Year made
- El. Elev. at top of boring, taken from tops.
- 10 Oct. 78 Date boring completed
- LL Liquid Limit
- PI Plasticity Index
- M Natural moisture content in percent
- Qu Unconfined Compressive Strength in Tons per sq. Ft.
- D.D. Dry Density in lbs. per cu. Ft.
- CL SANDY CLAY, Low plasticity
- SM SILTY SANDS,
- MH SANDY SILT (Siltstone)
- SC CLAYEY SANDS
- W.L. Water level and time measured in boring after completion
- N Standard penetration, blows per ft. required to drive a 2" C.D. Sampler by a 140 lb. wt. dropping 30 inches.

P-1

ATTACHMENT B

WATER SUPPLY AND WASTEWATER COLLECTION CALCULATIONS

PROJECT CERCLA WATER TREATMENT PLANT

SHEET NO. 1 OF 17

ITEM

LIFT STATION DESIGN

BY T. STRECKFUSS

DATE 6-25-90

CHKD. BY DMZ

DATE 7/90

1) DEVELOP DESIGN FLOWRATE:

MAXIMUM DISCHARGE FROM TREATED WATER TANKS = 20 gpm

- MAXIMUM DISCHARGE FROM DOMESTIC SYSTEM \Rightarrow

1 WATER CLOSET (FLUSHMETER) = 10 FIXTURE UNITS

1 LAVATORY (FAUCET) = 2 FIXTURE UNITS

 $\rightarrow 12 \text{ F.U.} \approx 28.6 \text{ gpm}$ \therefore TOTAL FLOW TO WETWELL = 48.6 gpm

SELECT DESIGN FLOW @ 60 gpm

2) DEVELOP SYSTEM HEAD CURVE: [FORCE MAIN = 2" ϕ ; C=130; L=510']

Q (gpm)	$H_{L \text{ STATIC}}$	$H_{L \text{ FRICTION}}$	$H_{L \text{ MINOR}}$	TDH (FT)
0		(STATIC HEAD)	NEGIGIBLE	1
20		5.7		7
40		20.6		22
60		43.5		45 ← DESIGN POINT
80		74.1		75
100		112.1		113

3) WETWELL: $V = \frac{\Theta q}{4}$ where Θ = PUMP TIME
 q = INCREMENTAL Q
 V = VOLUME (GALLONS)

USE 15 MIN. PUMP TIME, $\therefore V_1 = \frac{15(60)}{4} = 225 \text{ GALLONS}$

WETWELL DESIGN, @ 5 FT ϕ $\left[\frac{\pi}{4} (5)^2 \right] (7.48 \frac{\text{GAL}}{\text{FT}^3}) \doteq 150 \text{ GAL/FT}$

$\therefore \frac{225 \text{ GAL}}{150 \text{ GAL/FT}} = 1.5 \text{ FT FLOAT DEPTH } \textcircled{1}$

OMAHA DISTRICT	COMPUTATION SHEET	CORPS OF ENGINEERS	
PROJECT CERCLA		SHEET NO. 2	OF 17
ITEM LIFT STATION		BY STRECKFUS	DATE 6/25/90
		CHKD. BY DMR	DATE 7/90

FOR PUMP Z ; $q = 10$ gpm (DEPENDANT UPON SELECTED PUMP)

$$V_z = \frac{15(10)}{4} = 37.5 \text{ gallons.}$$

LIKewise, $\frac{37.5 \text{ gal}}{150 \text{ GAL/FT}} = .25 \text{ FT}$

SET FLOAT ELEVATIONS CONSISTENT W/ THESE DEPTHS :

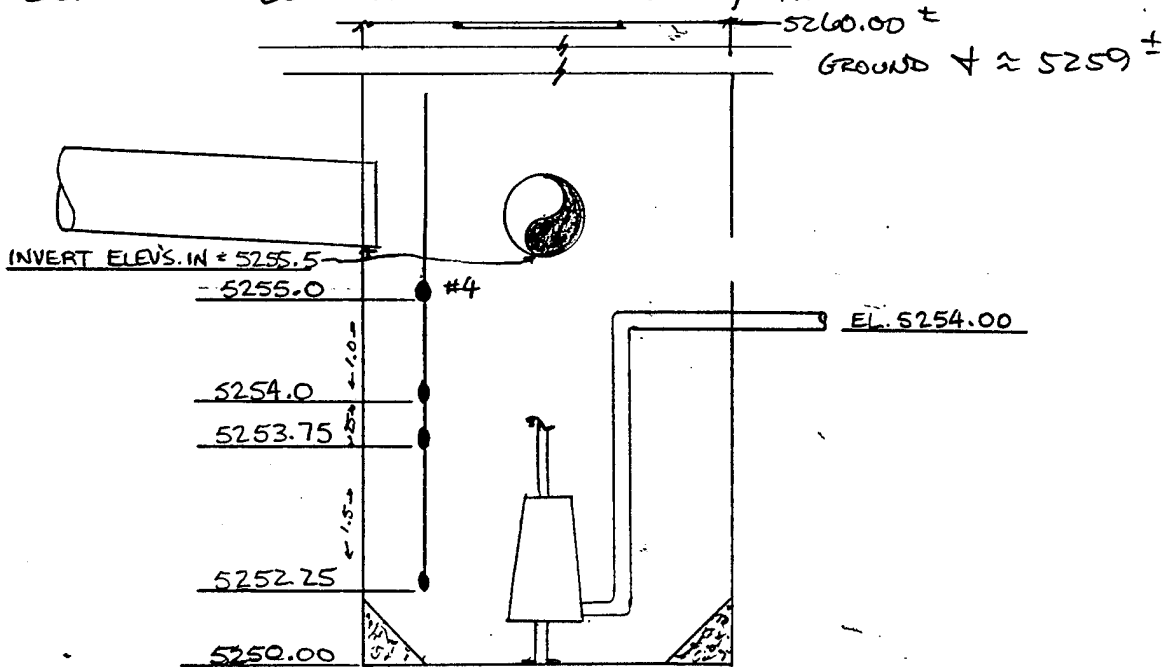

CERCLA WATER TREATMENT PLANT
- ROCKY MOUNTAIN ARSENAL, CO

25 JUNE 1990

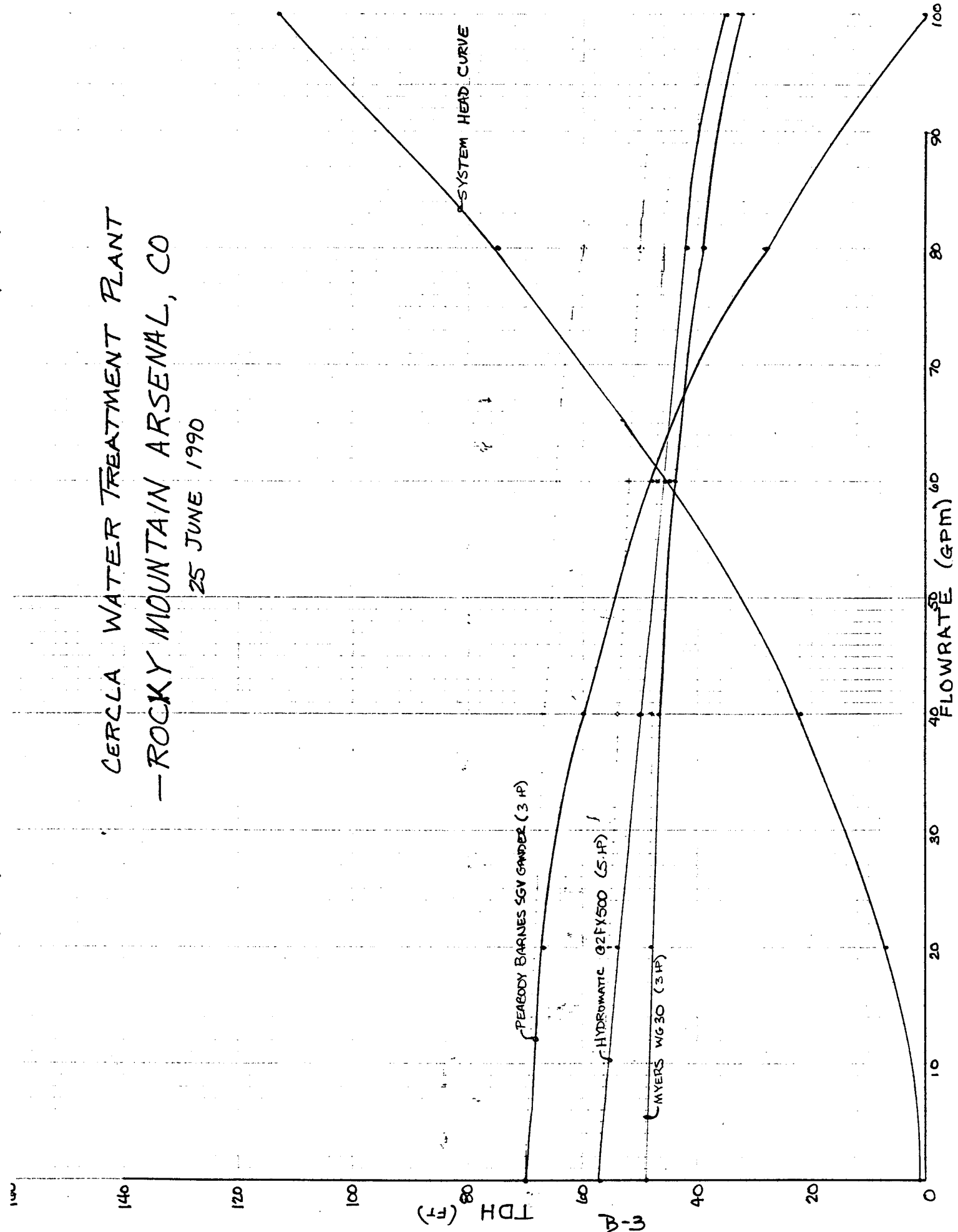

TDH (FT)

FLOWRATE (GPM)

PEABODY BARNES 5GV GANDER (3 HP)

HYDROMATIC Q2FY500 (5 HP)

MYERS WIG30 (3 HP)

SYSTEM HEAD CURVE

E-A

OMAHA DISTRICT	COMPUTATION SHEET	CORPS OF ENGINEERS	
PROJECT CERCLA WATER TREATMENT PLANT	SHEET NO. 4	OF 17	
ITEM WATER SERVICE	BY T. STRECHWIS	DATE 7/20/90	
	CHKD. BY JMR	DATE 7/90	

1) SIZE DOMESTIC WATER SERVICE TO FACILITY:

REQUIRED FLOW (SEE PAGE 1) FROM 12 FIXTURE UNITS
(DERIVED FROM NSPC HANDBOOK, TABLE 10.14.2A AND 10.14.2.B)
IS 28.6 gpm.

USING HAZEN-WILLIAMS EQUATION, WITH $C=130$ (SMOOTH PIPE)

THE SELECTED DIAMETER OF TWO INCHES RESULTS IN THE FOLLOWING H_L .

$$S = \left[\frac{3.5519 Q}{C D^{2.63}} \right]^{1.85}$$

WHERE D = DIAMETER (INCHES)
 Q = FLOWRATE (gpm)
 C = COEFFICIENT (130)
 S = SLOPE (FT/FT)

$$S = \left[\frac{3.5519 (28.6 \text{ gpm})}{130 (2)^{2.63}} \right]^{1.85}$$

$$= .0021 \text{ FT/FT} \rightarrow L = 140 \text{ FT} \therefore H_L = .3 \text{ FT}$$

VELOCITY IN SERVICE LINE (FROM CONTINUITY EQUATION)

IS AS FOLLOWS: $V = \frac{.4085 Q}{D^2}$ WHERE Q = gpm
 D = INCHES

$$V = \frac{.4085 (28.6 \text{ gpm})}{(2)^2} = 2.9 \text{ FT/S}$$

SINCE $2.9 < 6 \text{ FT/S}$, VELOCITY CHECKS.

\therefore SERVICE LINE DIAMETER = 2 IN.

OMAHA DISTRICT	COMPUTATION SHEET	CORPS OF ENGINEERS	
PROJECT CERCLA	SHEET NO. 5	OF 17	
ITEM	BY THS	DATE 20 July '90	
	CHKD. BY DNR	DATE 7/90	

SIZE DECONTAMINATION PAD SUMP PUMP:

VOLUME OF Sump $\rightarrow 4 \times 4 \times 3 = 48 \text{ Ft}^3 \times 7.48$

ASSUME PUMP DISCHARGE ELEVATION IS TWO FEET BELOW FINISHED FLOOR (ASSUMED 100.00) \therefore ELEV. = 98.00

TWELVE FOOT DIAMETER TANKS; 845 GAL/FT

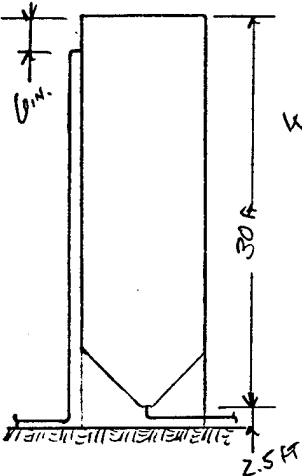

DISCHARGE PIPING FROM SUMP SHALL BE PIPED TO WITHIN 6" OF TOP OF TANK.

TANK HEIGHT ESTABLISHED AS 30 FT \pm
 SET FOOTING AND TANK SUPPORTS 2.5 FT ABOVE FINISHED FLOOR.

ELEVATION OF PIPE = 32 FT \pm ABOVE FINISHED FLOOR

TOTAL STATIC HEAD = 32 + 2 = 34 FT

ESTABLISH FLOW TO TANK AT AN ARBITRARY 35 gpm. THIS WILL ALLOW 1 TO 2 MINUTE RUN TIMES IN THE EVENT OF A DISCHARGE TO THE SUMP OF ONLY 1-55 GALLON DRUM.

- \rightarrow USE 1.5 INCH DIAMETER PIPE (VELOCITY = 6.4 FT/S)
- \rightarrow PIPING LENGTH = 65 FT \pm (WORST CASE)
- $\rightarrow H_L = .0122 \text{ FT/FT}$ $\therefore h_f = (.0122)65 \approx 1 \text{ FT}$
- \rightarrow ASSUME MINOR LOSSES = NEGLIGIBLE.

\therefore PUMP SELECTION \Rightarrow TDH = 35 FT ; Q = 35 gpm

PROCEDURE FOR DETERMINING BUILDING FIRE FLOW DEMAND
IN ACCORDANCE WITH MIL. HANDBOOK 1008A

LOCATION ROCKY MOUNTAIN ARSENAL FACILITY CERCLA WATER TRTMT. PLANT

Step 1: Building Parameters

- a. Type of Construction TYPE II-N
- b. Number of Stories ONE
- c. Hazard Classification ORDINARY - GROUP 2
- d. Area per Story 9450 FT²
- e. Exposed Facilities (within 150 ft)
 - 1st Facility _____ - NONE - ft
 - 2nd Facility _____ ft
 - 3rd Facility _____ ft
 - 4th Facility _____ ft
- f. Fire Suppression System Type WET PIPE
(If fully sprinklered, skip to step 8)

Step 2: Figure Selected Based on Step 1 Parameters

FIG. C-2A

Step 3: Basic Flow from Figure Selected in Step 2

1200 gpm

Step 4: Exposure Protection

- a. Separation Factor from Table 15
 - 1st Facility _____
 - 2nd Facility _____
 - 3rd Facility _____
 - 4th Facility _____
- b. Sum of Separation Factors _____
- c. Exposure factor from Figure C-4 _____
- d. Fire Flow Rate (rounded to 100 gpm) _____

Step 5: Flow Duration from Table C-1

2 HRS

Step 6: Minimum Residual Pressure

20 psi

Step 7: Additional Water Requirements

- a. Determine if Partial Sprinkler (Y/N) Yes
- b. Increases in Flow, Pressure and Duration _____

Step 8: Fire Flow Demand for Building Completely Protected by Sprinkler System (Table 10)

- a. 15% increase for piping variations $(3000)(.20) = 600 \text{ gpm}$
- b. 30% increase for dry-pipe systems $(600)(.15) = 90 \text{ gpm}$
(only one increase per system) φ
- c. Exterior hose streams (Table 10) 500 gpm → USE 1200 FROM ABOVE
- d. Duration: (Table 10) 75 min → USE 2 HRS
- e. Total flow to facility 690 gpm INTERIOR
1200 gpm EXTERIOR

CONVERSATION RECORD

TIME: 1000

DATE: 14 March 1990

Type:	<input type="checkbox"/> visit	<input type="checkbox"/> conference	<input checked="" type="checkbox"/> phone	Routing	
			<input type="checkbox"/> incoming	Office	Int.
Location:			<input checked="" type="checkbox"/> outgoing		
Person(s) in contact with:	Phone:				
Name and Organization					
Donald G. Hager	(602) 327-0277				
Peroxidation Systems Inc.					
4400 E. Broadway, Suite 602					
Tucson, Arizona 85711					
Subject:	UV Oxidation/peroxidation systems.				

Summary:

I contacted Peroxidation Systems Inc. to determine the availability of a low flow unit capable of providing treatment in this treatment facility. I was told that Model LV-60 would be an appropriate model for the application. The unit reactor is constructed of 316 SS. The dimensions of the unit are 2' X 8' X 5.5' Tall, and the unit is skid mounted. The hydrogen peroxide storage unit is approximately 4 to 5 feet tall, with a 300 to 500 gallon capacity. Power requirements are 480 Volt, 3 Phase, with a 100 amp disconnect. Power usage is 60 kW. An additional point of contact at Peroxidation Systems Inc., Tucson, (Carl Loven) was provided.

The increase in water temperature across unit (at 6 gpm) is estimated at 70 degrees (F).

I was subsequently contacted by Max Fairchild (409) 833-7075, calling from Beaumont, Texas. He indicated that a demo unit could be provided for testing purposes. He indicated that the unit was effective where carbon was not on vinyl chloromonomer.

Action Required:

Person documenting conversation	Signature	Date
Ted H. Streckfuss, P.E.	<i>Ted H. Streckfuss</i>	20 June 1990

Action Taken:

Signature	Title	Date

MEMORANDUM to FILE

To: CERCLA Information file

From: Ted H. Streckfuss, Environmental Engineer

TD May 17, 1990

Subject: ULTROX International

Summary:

While in Philadelphia for training at the International Forum on Hazardous Waste Technologies, the Senior VP from Ultrox gave a presentation on their system. The following is a synopsis of the presentation:

1) There is a full scale system installed in Southgate, CA.

2) Utilizes Ozone (triatomic Oxygen)
H₂O₂ (FMC Corporation)
UltraViolet light* (254 nm wavelength-short light)

--This is a wavelength which gives sunburn.

3) End products of CO₂ and salts. The transformation to OH-radicals enhances removal.

4) MEK and CCl₄ are difficult to remove through this process.

5) Hexane, Heptane (aliphatic compounds) are nearly impossible to remove using this process.

6) Hardness tends to coat the interior of the reactor

7) Fe and Mg should be limited to < 10 to 20 ppm.

8) pH is critical to system operation. A pH less than 4 is not good. Optimum pH is between 5.5 and 6.5. A high pH is also not good because of NH₃.

9) Brackish water (salts) are not desirable.

10) Typical process pathway:

. Aromatic -> organic acids -> CO₂

Ex.: Isopropyl alcohol -> Acetone -> Acetic acid -> CO₂

CONVERSATION RECORD

TIME: 0900

DATE: 14 March 1990

Type:	<input type="checkbox"/> visit	<input type="checkbox"/> conference	<input checked="" type="checkbox"/> phone	Routing	
			<input type="checkbox"/> incoming	Office	Int.
Location:	Omaha District		<input checked="" type="checkbox"/> outgoing		
Person(s) in contact with:			Phone:		
Name and Organization					
Glen Fleharty			(402) 895-6336		
14243 S Street			RAINES & ASSOCIATES		
Omaha, NE 68137			(supplier)		

Subject:
Chemical Precipitation unit.

Summary:

I contacted Glen regarding appropriate companies capable of supplying units which would adequately remove metals through metal precipitation. I indicated I had contacted Great Lakes Environmental (312) 543-9444 in Addison, IL. They in turn sent product information.

Glen indicated that the unit which would handle the required flowrate would have the dimensions of approximately 2 ft x 6'4" x 6'6" tall (for the inclined plate clarifier) and 4' x 8' x 5' tall for the flash/floc tank (each unit approximately 2' wide).

Also required would be 2 - 50 gallon drums fitted with metering pumps and mixers for the NaOH, H₂SO₄ and polymer.

Action Required:

Person documenting conversation	Signature	Date
Ted H. Streckfuss, P.E.	<i>Ted H. Streckfuss</i>	21 June 1990

Action Taken:

Signature	Title	Date

CONVERSATION RECORD

TIME: 1100

DATE: 15 March 1990

Type:	<input type="checkbox"/> visit	<input type="checkbox"/> conference	<input checked="" type="checkbox"/> phone	Routing	
			<input type="checkbox"/> incoming	Office	Int.
Location:	Omaha District		<input checked="" type="checkbox"/> outgoing		
Person(s) in contact with:			Phone:		
Name and Organization					
Gregg Backstrom			(612) 935-1844		
Carbon Air Services, Inc.					
PO Drawer 5117					
Hopkins, MN 55343					

Subject:
Modular Activated Carbon Units.

Summary:

Gregg indicated that modular units would work well in the CERCLA installation. He recommended a 15 gpm unit for this system. The referenced unit dimensions are 4 foot diameter X 7'6" Tall.

Action Required:

Person documenting conversation	Signature	Date
Ted H. Streckfuss, P.E.	<i>Ted H. Streckfuss</i>	21 June 1990

Action Taken:

Signature	Title	Date

CONVERSATION RECORD

TIME: 1000

DATE: 15 March 1990

Type:	<input type="checkbox"/> visit	<input type="checkbox"/> conference	<input checked="" type="checkbox"/> phone	Routing	
			<input type="checkbox"/> incoming	Office	Int.
Location:	Omaha District		<input checked="" type="checkbox"/> outgoing		
Person(s) in contact with:			Phone:		
Name and Organization					
	Bob Lake		(602) 946-7093		
	Water Treatment Engineering				
	Scottsdale, Arizona				

Subject:
Activated Alumina

Summary:

Prior to contacting Mr. Lake, I researched the following suppliers/designers of activated alumina:

- Alcan -> 800-321-3864
- Industrial Chemical Division -> 800-643-8771
- LaRouche Chemical (Baton Rouge) -> 800-524-2586
- specific POC is John Hutchinson at 504-356-8422 (sent informational papers.)
- Zurn Industries -> 814-453-3651

-- The former references were derived from the Chemical Engineering Handbook (CEC). --

Mr. Lake provided me with the following information:

- A) NaOH is used to clean the media.
- B) H₂SO₄ is used to neutralize the NaOH.
- C) Potential problem associated with the development of fines/plugging.
- D) EPA - Cincinnati is a useful source of information.
- E) There is differing regeneration criteria between Arsenic and Fluoride.
- F) Optimum operation occurs at a pH of 5.5. This will require acidification of the influent prior to operation. Following the run through the unit, neutralization can be accomplished with NaOH, increasing the pH to 7.3 -> 7.8 range.
- G) Operation in a downflow mode anticipated. Utilize 30 inch column.
- H) Filtration prior to operation is highly recommended.
- I) Alcoa - Initial load. Backwash with pH of 2. This will bring the pH down of the media as well as wash out the fines.

J) It is estimated that the treatment efficiency will be decreased to 1/5 if not pH adjustment is carried out.

K) Cost is estimated at \$.65 to \$.70 per pound of material (LaRouche). Alcoa estimates cost at \$1.00 per pound.

L) Media is Arsenic preferential. Breakthrough on Fluoride will occur before Arsenic. Fluoride will work well as a monitoring guideline for determining system breakthrough.

M) Estimated will remove 12 grams Arsenic/cubic foot (this assumes no competition from other materials).

N) Provided reference for Fred Rouble (Rouble & Haven - Arsenic Removal pilot Plant Removal of As and F1; Fallon AFB, NV).

Action Required:

Person documenting conversation	Signature	Date
Ted H. Streckfuss, P.E.	<i>Ted H. Streckfuss</i>	21 June 1990

Action Taken:

Signature	Title	Date

CONVERSATION RECORD

TIME: 0700

DATE: 20 June 1990

Type:	<input type="checkbox"/> visit	<input type="checkbox"/> conference	<input checked="" type="checkbox"/> phone	Routing	
			<input type="checkbox"/> incoming	Office	Int.
Location:	Omaha District		<input checked="" type="checkbox"/> outgoing		
Person(s) in contact with:	Phone:				
Name and Organization					
	Mr. Ernie Rosenberg	(216) 327-6051			
	XERXES Tank Manufacturer (FRP)				
	Cleveland, Ohio				

Subject:
 Tank type to be used in CERCLA Water Treatment Plant.

Summary:
 I originally contacted the Corporate headquarters in Minneapolis, MN. Jack Berkland provided me with Cleveland personnel (Ernie Rosenberg and Bob Hahn) at the referenced number, and Larry Hurst in Anaheim, CA (714) 630-0012. I contacted Mr. Rosenberg to determine if FRP tanks would be amenable to the CERCLA Treatment Plant. Mr. Rosenberg indicated that if carbon steel tanks were capable of containing the liquid, (on the basis of compatibility) the fiber reinforced polyethylene (FRP) tanks would not be cost competitive.
 Mr. Rosenberg indicated that FRP tanks would cost approximately \$1.00 to \$1.50 per gallon for the tanks (i.e. \$20,000 per tank). He indicated that carbon steel would cost roughly half that amount, or \$.50 to \$.75 per gallon, which equates to \$10,000 per tank.
 Mr. Rosenberg indicated that he would send product literature to this office for future reference.

ADD. COST FOR EPOXY LINER IN STEEL = 25¢/gallon STORAGE.

DT 19 July '90

Action Required:

Person documenting conversation	Signature	Date
Ted H. Streckfuss, P.E.	<i>Ted H. Streckfuss</i>	20 June 1990

Action Taken:

Signature	Title	Date

CONVERSATION RECORD

TIME: 1300

DATE: 16 July 1990

Type:	X_ visit	___ conference	X_ phone	Routing
			___ incoming	Office Int.
Location:	Omaha District		X_ outgoing	
Person(s) in contact with:	Phone:			
Name and Organization	(414) 764-5700			
	Tom Cvetan			
	Kisco Boiler and Engineering Co.			
	303 West Marquette Ave.			
	Oak Creek, WI 53154			
Subject:	Dual media sand filters			

Summary:

I contacted Kisco Boiler & Engineering Co. to determine if they marketed a filtration system capable for use in the CERCLA Water Treatment Plant. I indicated that the filtration system should be capable of handling a wide variety of influent conditions. I indicated that the filter should be capable of removing particles down to the 10 - 20 micron range. Assumed influent characteristics with Suspended Solids approximately 50 - 75 mg/l.

Mr. Cvetan indicated that they did have a system capable of meeting the performance requirements indicated in the former paragraph. The preferred unit would have the following characteristics:

- 20 inch diameter tank
- 60 inch sidewall length
- app. 2.2 square feet surface area
- app. 30 - 40 gpm required for backwash
- 80 mg/l maximum suspended solids (to prevent excessive backwashing)
- Carbon steel vessel with epoxy coated liner
- Backwash is normally based upon timer
- Cost/unit = \$1,600.00

Mr. Cvetan also indicated that for consistent removal to the 10 - 20 micron range, an additional layer of garnet would be required within the pressure vessel. Typical configuration of the packing media would be as follows:

- Top layer = Anthracite coal
- 2nd layer = .45 to .55 micron filter sand
- 3rd layer = 30 x 40 mesh garnet
- 4th layer = 8 x 12 mesh garnet
- bottom layer = support gravel over plenum.

Mr. Cvetan indicated that he would send some product information to provide additional data regarding the referenced unit.

Action Required:

Person documenting conversation	Signature	Date
Ted H. Streckfuss, P.E.	<i>Ted H. Streckfuss</i>	16 July 90

Action Taken:

Signature	Title	Date
	B-14	

CONVERSATION RECORD

TIME: 1400

DATE: 16 July 1990

Type:	X_ visit	__ conference	X_ phone	<u>Routing</u>	
			__ incoming	<u>Office</u>	<u>Int.</u>
Location:	Omaha District		X_ outgoing		
Person(s) in contact with:			Phone:		
Name and Organization			(708) 205-6000		
Desh Pande					
Culligan Int'l Co.					
Northbrook, Illinois 60062					

Subject:
Multi-media filtration

Summary:

I contacted Culligan International regarding applications for pressure filtration vessels. I provided information regarding specifics required at the CERCLA Water Treatment Plant; i.e. 10 - 20 micron particle range, influent suspended solids approximately 50 to 89 mg/l, and influent flowrate 15 gallons per minute.

Mr. Pande indicated that Culligan manufactured several packaged units that would be capable of meeting the specified requirements. Model PV 16D, listing at \$1,573.00, is capable of treating 14 gpm. Tank configuration is as follows:

- 1.5 inch pipe connections
- 16 inch tank diameter
- 37 inch tank sidewall
- 14 gpm/ft² backwash rate
- backwash initiated by timer or pressure differential across filter bed
- carbon steel tank with epoxy liner

Mr. Pande also indicated that the 22 gpm model may work better for this application. This model (HD 20) lists for \$2,635 and has the following characteristics (different from the PV 16D):

- tank diameter = 20 inches
- tank sidewall depth = 54 inches

For additional information, Mr. Pande referenced me to the local dealer at 75th and D Streets in Omaha. Telephone (402) 397-4234

Mr. Pande indicated that the filter media relies upon anthracite, filter sand and garnet to achieve optimum performance during filter operation.

Action Required:

Person documenting conversation	Signature	Date
Ted H. Streckfuss, P.E.	<i>Ted H. Streckfuss</i>	17 July 90

Action Taken:

Signature	Title	Date

16/j17

CONVERSATION RECORD

TIME: 1300

DATE: 16 July 1990

Type:	<input type="checkbox"/> visit	<input type="checkbox"/> conference	<input checked="" type="checkbox"/> phone	Routing
			<input type="checkbox"/> incoming	Office
			<input checked="" type="checkbox"/> outgoing	Int.

Location: Omaha District

Person(s) in contact with:	Phone:
Name and Organization	
Gregg Backstrom	(612) 935-1844
Carbon Air Services, Inc.	
PO Drawer 5117	
Hopkins, MN 55343	

Subject:
Modular Activated Carbon Units, Vapor phase carbon units and air stripping.

Summary:

Henry Baldwin and myself contacted Gregg to obtain information regarding costs associated with modular GAC units, air strippers and vapor phase carbon. Gregg had previously provided costs to Henry concerning the costs for the modular carbon units.

Gregg indicated that the vapor phase carbon unit on the air stripper would consist of a 150 pound carbon canister (22 inches diameter by 43 inches tall), model number GPC-3. Estimated cost associated with this unit were assessed at \$750.00.

For the air stripper, Gregg indicated that an air to water ratio of 40 or 50 to one is (40 - 50:1) is normally selected. It is preferable to minimize air flow when vapor phase carbon is utilized on the off-gas. The indicated air stripper had the following characteristics. Note that the diameter is 16 inches. It was felt that the twelve inch diameter stripper impacted treatment efficiency due to wall effects:

- carbon steel sump
- effluent pump included in package
- controls included (level, start/stop, etc.)
- app. 30 foot height
- a:w = 40 - 50:1
- Estimated cost \$16,000.00

Typical packing used is Jaeger tripacks, although other options are available.

A heater is necessary on the off-gas in order to optimize performance and extend the life of the vapor phase carbon unit. The heater unit raises the air temperature of the off-gas approximately 50 degrees Fahrenheit to reduce the humidity to < 50 percent. Typically, a 4 kW heater is adequate, with an approximate cost of \$2,000. This unit fits in-line on the 4 or 6 inch duct line off of the air stripper.

Action Required:

Person documenting conversation	Signature	Date
Ted H. Streckfuss, P.E.	<i>Ted H. Streckfuss</i>	17 July 90

Action Taken:

Signature	Title	Date

VERTICAL STORAGE TANK

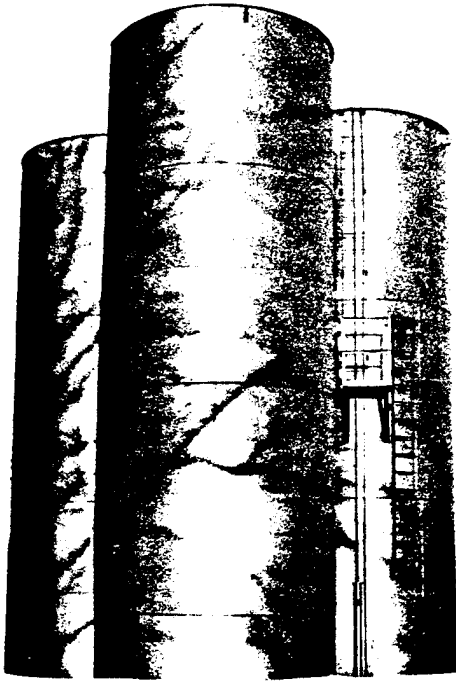

Customer to specify size and location of fittings on vertical tanks (normal and emergency venting required). Installations vary as to piping requirements.

Highland Vertical Tanks bear U.L. Label and are coated with red primer paint.

Maximum height of U.L. vertical tank shell is 35'0".

U.L. labeled vertical tanks require coned heads.

Tanks for storage of fertilizers, potable water, chemicals, etc., with appropriated linings are available on request. Tanks may be equipped with coned bottoms, legs, etc., to meet your requirements.

Tanks available in carbon or stainless steel.

SPECIFICATIONS

ELEVATIONS

CAPACITY (GALLONS)	DIAMETER (D)	HEIGHT (H)	GAUGE (THICKNESS)		WEIGHT (POUNDS)
			SHELL & BOTTOM HEAD	TOP CONED HEAD	
500	48"	5'5"	7ga	7ga	711
1,000	64"	6'0"	7ga	7ga	1,087
2,000	64"	12'0"	7ga	7ga	1,988
3,000	64"	18'0"	7ga	7ga	2,749
4,000	96"	10'6"	1/4"	7ga	4,009
5,000	8'0"	13'4"	1/4"	7ga	4,706
6,000	8'0"	16'0"	1/4"	7ga	5,402
8,000	10'0"	14'0"	1/4"	7ga	6,415
10,000	10'0"	17'0"	1/4"	7ga	7,532
12,000	10'0"	20'6"	1/4"	7ga	8,649
15,000	10'0"	25'6"	1/4"	7ga	10,213
20,000	10'0"	34'0"	1/4"	7ga	13,117
25,000	12'0"	29'8"	1/4"	7ga	14,248
29,500	12'0"	35'0"	1/4"	7ga	16,320

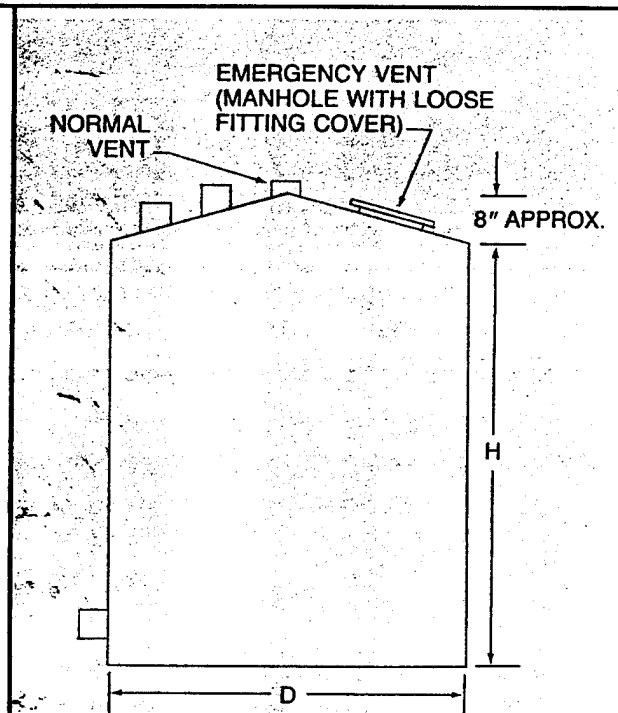

Highland Tank and Manufacturing Company

Stoystown, PA 15563-0338 (814) 893-5701

Fax. No. (814) 893-6126

Manheim, PA 17545-9410 (717) 665-6877

Fax. No. (717) 665-2790

ATTACHMENT C
STRUCTURAL CALCULATIONS

PROJECT CERLLA WATER TREAT. - ROCKY MTH. CO.

SHEET NO. 1 OF 19

ITEM

35% PRELIMINARY

BY OM

DATE 6/29/92

CHKD. BY

DATE

DESIGN

BUILDING TYPE CATEGORY 1

EXPOSURE CATEGORY C

PARTIALLY HEATED STRUCTURE

 C_e , EXPOSURE FACTOR = 1.0 C_t , THERMAL FACTOR = 1.1 I , SNOW LOAD IMPORTANCE FACTOR = 1.0 P_g , GROUND SNOW LOAD = 15 psf

$$p_f = 0.7 C_e C_t I P_g$$

 C_s , SLOPE REDUCTION FACTOR = 1.0

$$p_f = 0.7 \times 1.0 \times 1.1 \times 1.0 \times 15.0 = 11.55 \text{ psf}$$

BASED ON LOCAL PRACTICE THE MINIMUM
SNOW LOAD = 30 psf

$$\text{UNBALANCED SNOW LOAD} = 1.5 \text{ psf}/C_e = 1.5 \times 11.55 = 17.32 \text{ psf}$$

 s , DRIFT DENSITY = 15 psf

PROJECT CERCLA WATER TREATMENT PLANT-

SHEET NO. 2

OF

ITEM

ROCKY MOUNTAIN ARSENAL
COLORADO

BY OM

DATE 6/5/90

ROOF SNOW LOAD

CHKD. BY

DATE

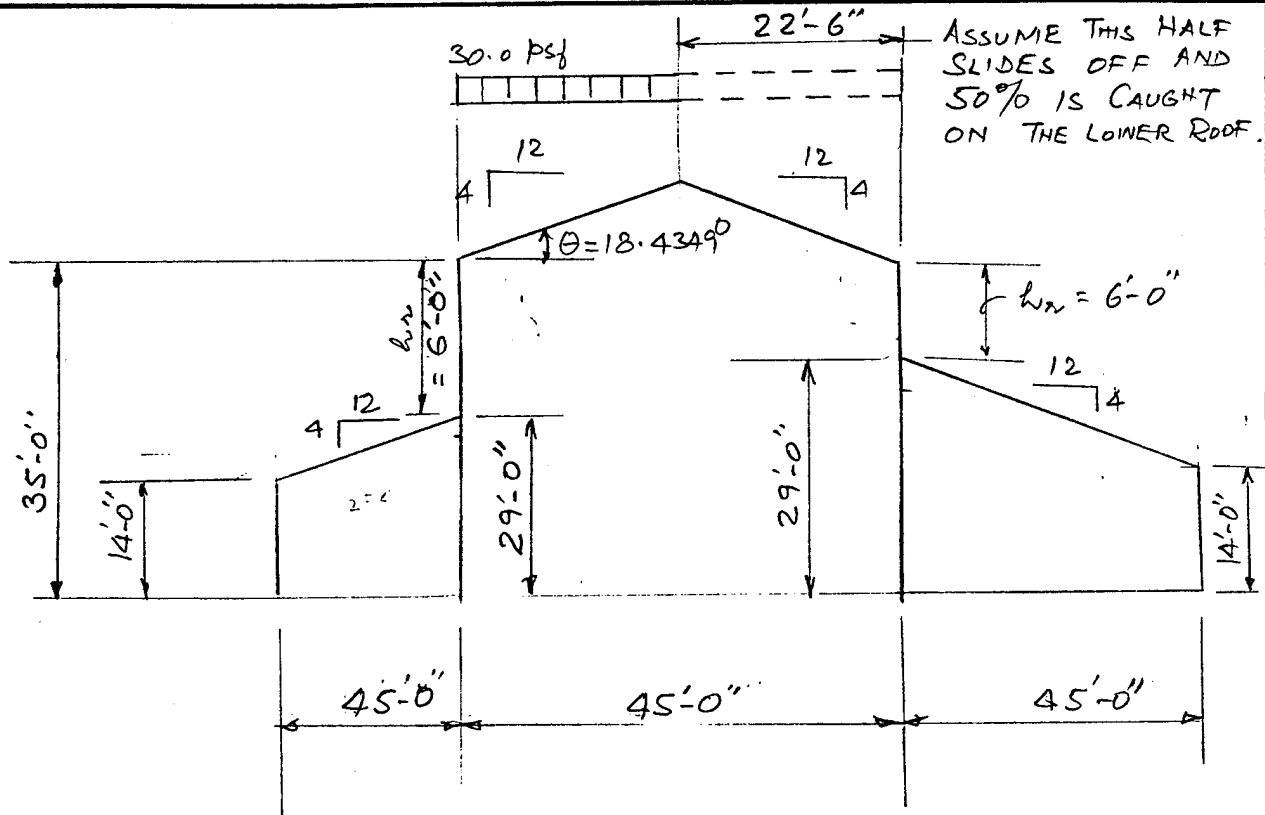

BALANCED LOAD 30 psf

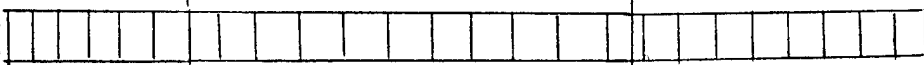

DRIFT LOAD

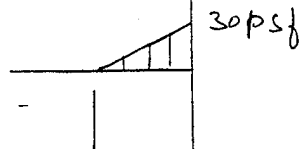

SLIDING LOAD 18.75 psf

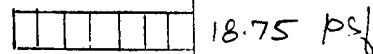

COMBINED LOAD

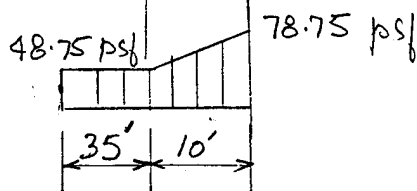

PROJECT CERCLA - ROCKY MTN ARS CO.

SHEET NO. 3 OF

ITEM

SNOW LOAD

BY DM

DATE

CHKD. BY

DATE

DRIFT SNOW LOAD: P_d

$$\gamma = 15 \text{ pcf}$$

$$h_w = P_s / \gamma = 30.0 / 15.0 = 2.0 \text{ ft.}$$

$$h_c = (6.0 - h_w) = (6.0 - 2.0) = 4.0 \text{ ft}$$

$$h_c / h_w = 4.0 / 2.0 = 2.0 > 0.2$$

Therefore consider Drift Load.

$$h_d = 2I_p \gamma / C_e \gamma$$

$$= 2 \times 1.0 \times 15.0 / (1.0 \times 15.0)$$

$$= 2.0 \text{ ft}$$

$$P_d = h_d \gamma = 2 \times 15.0 = 30 \text{ psf}$$

Width of Drift for $L \leq 50 \text{ ft}$

$$W = 3h_d = 3 \times 2.0 = 6.0' \quad \text{Minimum } 10.0' \text{ should be used}$$

SLIDING SNOW LOAD:

Sliding Snow Load uniformly distributed on lean-to roof.

$$(0.5 \times 30.0 \times 25) / 20.0 = 18.75 \text{ psf}$$

PROJECT CERCLA - ROCKY MTH ARS Co.

SHEET NO. 4

OF

ITEM

BY OM

DATE

WIND LOADS

CHKD. BY

DATE

CATEGORY TYPE 1

EXPOSURE C

WIND LOAD IMPORTANCE FACTOR, $I = 1.0$ GUST RESPONSE FACTOR = G_R ; VELOCITY PRESSURE EXPOSURE
HEIGHT ABOVE GROUND LEVEL G_R COEFFICIENT = K_Z

HEIGHT ABOVE GROUND LEVEL (ft.)	G_R	K_Z
0-15	1.32	0.80
20	1.29	0.87
25	1.27	0.93
30	1.26	0.98
40	1.23	1.06
50	1.21	1.13

Main Wind-force Resisting System:

A. $p = q C_e C_p$ External Wind Pressure on
the Building

$$q_z = 0.00256 K_z (I V)^2$$

$$K_z = 0.87 \text{ @ } 20' \text{ Height}$$

$$q_z = 0.00256 \times 0.87 (1.0 \times 85.0)^2$$

$$= 16.1 \text{ psf}$$

PROJECT CERCLA - Rocky Mtn Ars Co.

SHEET NO. 5 OF

ITEM

BY OM

DATE

WIND LOADS

CHKD. BY

DATE

EXTERNAL WALL PRESSURE COEFFICIENTS, C_p :

$$p = q_z G_w C_p \text{ Windward wall only}$$

$$p = q_w G_w C_p \text{ All other walls}$$

Surface	L/B	C_p	FOR USE WITH
Windward Wall	ALL VALUES	0.8	q_z
Leeward Wall	2	-0.5	q_w
Side Wall	ALL VALUES	-0.7	q_w

Windward WALL:

$$p = q_z G_w C_p = 16.1 \times 1.29 \times 0.8 = 16.62 \text{ psf}$$

Consider inclusion of internal pressure:

$$p = q_w G_w C_p - q_w (G C_{pi})$$

$$G C_{pi} = \pm 0.25$$

$$p = 16.62 - 16.1(-0.25) = 16.62 - (-4.02) = 20.64 \text{ psf}$$

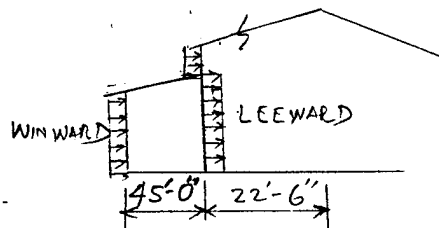

$$\begin{aligned} \text{Leeward wall} &= (16.1 \times 1.29 \times -0.5) - 16.1(+0.25) \\ &= 14.46 \text{ psf} \end{aligned}$$

$$\text{SIDEWALL } (16.1 \times 1.29 \times -0.7) - 16.1(+0.25) = 18.56 \text{ psf}$$

FOR WALLS USE $p = 21 \text{ psf}$.

OMAHA DISTRICT	COMPUTATION SHEET	CORPS OF ENGINEERS	
PROJECT CERCLA WATER TREAT. - ROCKY MTN	ARS CO	SHEET NO. 6	OF
ITEM		BY DM	DATE
WIND LOADS		CHKD. BY	DATE

Roof Pressure Coefficients C_p :

	WINDWARD		LEEWARD	
	Angle	h/L	h/L	θ
Normal to Ridge	θ	0.5 1.0		
	<u>18.434°</u>	<u>$-0.75 \quad -0.75$</u>		

-0.7 for all values of h/L and θ

Parallel to Ridge $h/B \leq 2.5$. USE $C_p = -0.7$ for all roof areas.

$p = 16.62 - 16.1(-0.75) = 29.69 \text{ psf}$
 FOR MAIN ROOF FRAME SYSTEM USE 29 psf.

OMAHA DISTRICT	COMPUTATION SHEET	CORPS OF ENGINEERS	
PROJECT CERCLA WATER TREATMENT PLANT	SHEET NO. 7	OF	
ITEM ROCKY MOUNTAIN ARS. CO.	BY OM	DATE	
	CHKD. BY	DATE	

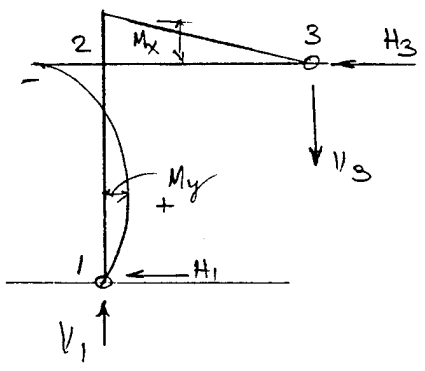
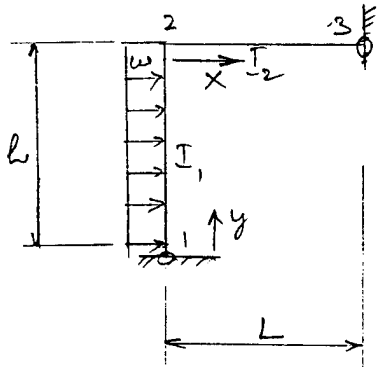

REFER PAGE 115 OF BEAM FORMULAS BY WILLIAM GRIFFEL

$$C = \frac{I_2}{I_1} \left(\frac{h}{L} \right)$$

ASSUME $I_2 = I_1$

$$\therefore C = \frac{h}{L}$$

$$M_2 = - \frac{w h C}{8(C+1)}$$

$$M_2 = - \frac{w h \times \frac{h}{L}}{8\left(\frac{h}{L} + 1\right)}$$

$$= - \frac{w h^2 / L}{8\left(\frac{h+L}{L}\right)} = - \frac{w h^2}{8(h+L)} \quad ; \text{ USE WIND } 25 \text{ psf.}$$

$$M_2 = - \frac{25 \times (14.0)^2}{8(14.0 + 45)} = - 10.38$$

$$V_1 = -V_3 = - \frac{M_2}{L} = - \frac{10.38}{45} = - 0.2307$$

$$H_1 = - \frac{w h}{2} - \frac{M_2}{h} = - \frac{25 \times 14}{2} + \frac{10.38}{14} = - 174.26$$

$$H_3 = \frac{w h}{2} - \frac{M_2}{h} = \frac{25(14.0)}{2} - \left(- \frac{10.38}{14.0} \right) = 175.74$$

PROJECT CERCLA WATER TREATMENT PLANT

SHEET NO. 8 OF

ITEM

ROCKY MTN. ARS. COLORADO

BY OM

DATE

CHKD. BY

DATE

$$[48.75 \times 45 + 30 \times 10/2] \div 45 = 52 \text{ psf}$$

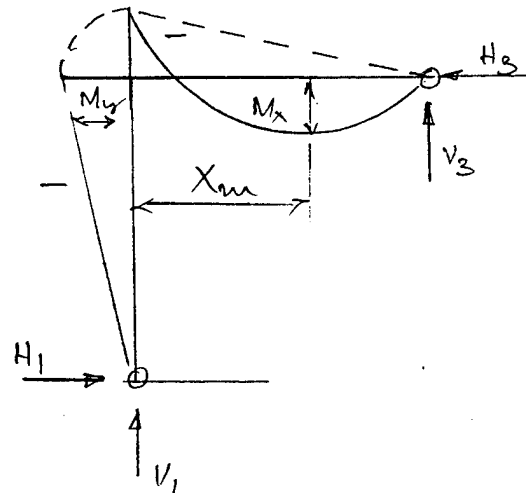
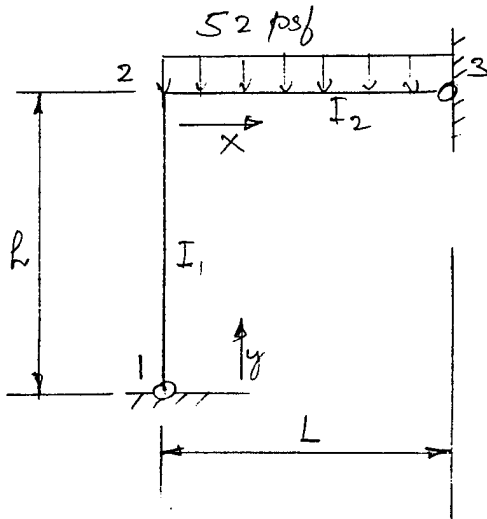

$$M_2 = \frac{\omega L^2}{8(C+1)} = \frac{\omega L^2}{8(\frac{h}{L}+1)}, \text{ ASSUMING } I_1 = I_2$$

$$M_2 = \frac{\omega L^2}{8(\frac{h+L}{L})} = \frac{\omega L^3}{8(h+L)} = \frac{52 \times 45^3}{8(14.0+45)} = 10,039 \text{ ft-lb}$$

$$H_1 = H_3 = \frac{M_2}{h} = \frac{10,039}{14.0} = 717.1 \text{ LB.}$$

$$V_1 = \frac{\omega L}{2} - \frac{M_2}{L} = \frac{52 \times 45}{2} - \frac{10,039}{45} = 946.9$$

$$V_3 = \frac{\omega L}{2} + \frac{M_2}{L} = \frac{52 \times 45}{2} + \frac{10,039}{45} = 1393.1$$

PROJECT CERCLA WATER TREAT. ROCKY
ITEM MTN. ARS. CO.

SHEET NO. 9 OF

BY OM

DATE

CHKD. BY

DATE

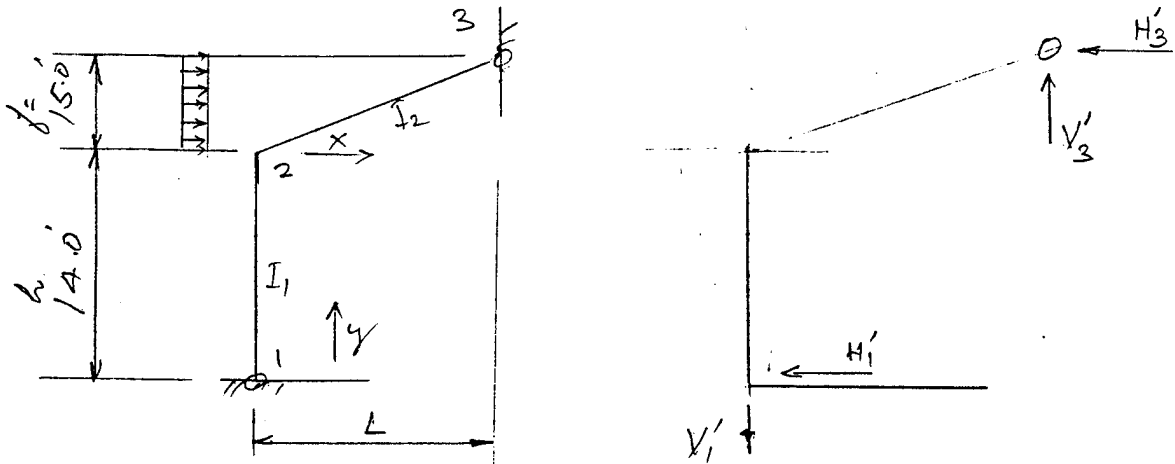

$$V'_1 = V'_3 = V' = \frac{wf(2h+f)}{2L} = \frac{25 \times 15(2 \times 14 + 15)}{2 \times 45.0}$$

$$V'_1 = V'_3 = 179.17$$

$$H'_3 \approx H'_1 = \frac{25 \times 15}{2} = 187.5$$

OMAHA DISTRICT	COMPUTATION SHEET	CORPS OF ENGINEERS	
PROJECT CERCLA WATER TREAT. ROCKY MTN.	ARS. CO.	SHEET NO. 10	OF
ITEM		BY OM	DATE
		CHKD. BY	DATE

REFER FIG 3.28 OF APPLIED STRUCTURAL DESIGNS OF BUILDINGS 3RD ED. BY MCKAIG

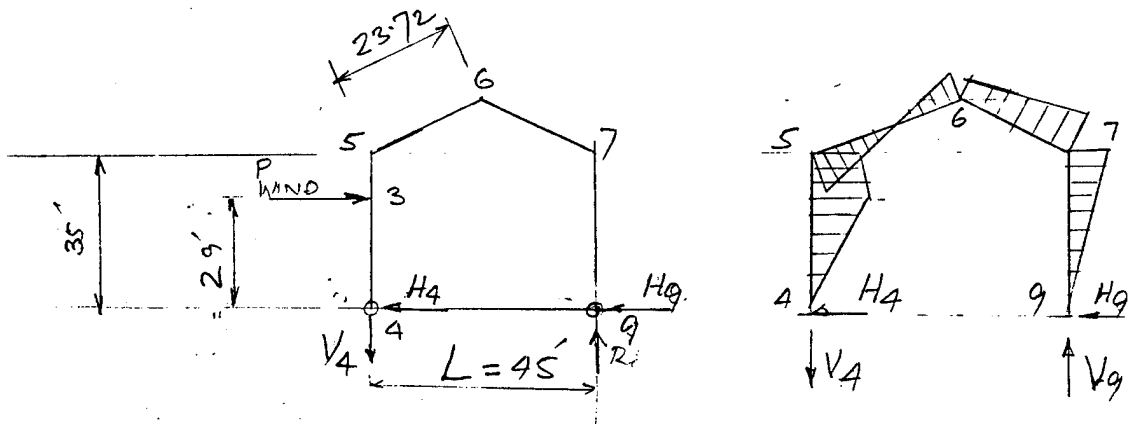
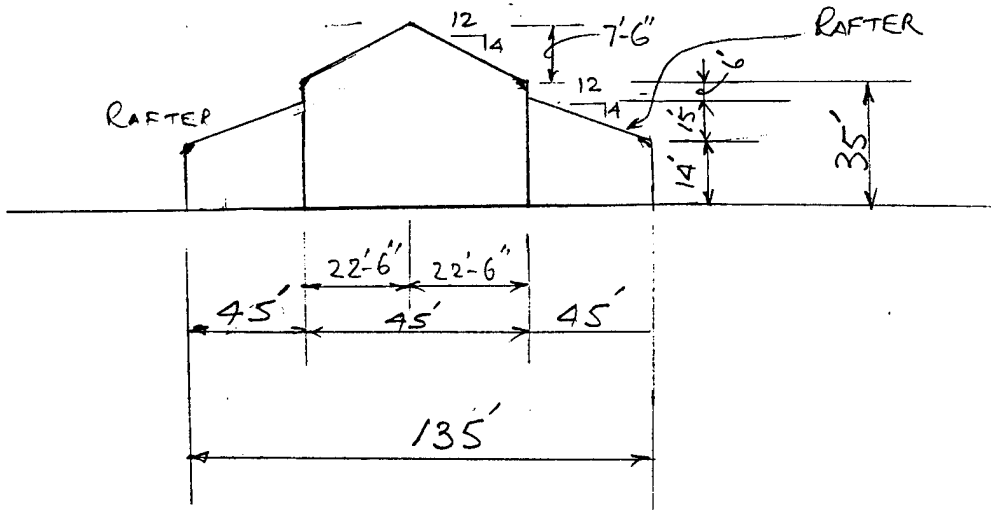

$$V_4 = V_9 = V = \frac{P \cdot l \cdot h}{L} = \frac{363.24 \times 29.0}{45.0} = 234.09 \text{ LB}$$

$$P = 175.74 + 187.5 = 363.24$$

$$H_9 = \frac{P \cdot l}{N} (3C - l^2 C + G + 3Q) = \frac{234.09 \times 0.83}{8.83} (3 \times 1.48 - 0.83^2 \times 1.48 + 6 + 3 \times 1.07)$$

$$Q = l/r = \frac{15.0}{14.0} = 1.07$$

$$C = \frac{I_2 \cdot h}{I_1 \cdot m} = \frac{35.0}{23.72} = 1.48, \text{ ASSUME } I_2 = I_1$$

$$l = 29/35 = 0.83; N = (C + 3 + 3Q + Q^2) = 8.83$$

PROJECT CERCLA WATER TREAT. ROCKY MTN.

SHEET NO. 11 OF

ITEM ARS CO.

BY OM

DATE

CHKD. BY

DATE

$$\begin{aligned}
 H_B &= \frac{Pl}{N} (3C - l^2C + 3Q) \\
 &= \frac{363.24 \times 0.83}{0.83} (3 \times 1.48 - 0.83^2 \times 1.48 + 3 \times 1.07) \\
 &= 34.1437 (4.44 - 1.0196 + 3.21) \\
 &= 226.38 \text{ LB}
 \end{aligned}$$

$$H_A = P - H_B = 363.24 - 226.38 = 136.86 \text{ LBS.}$$

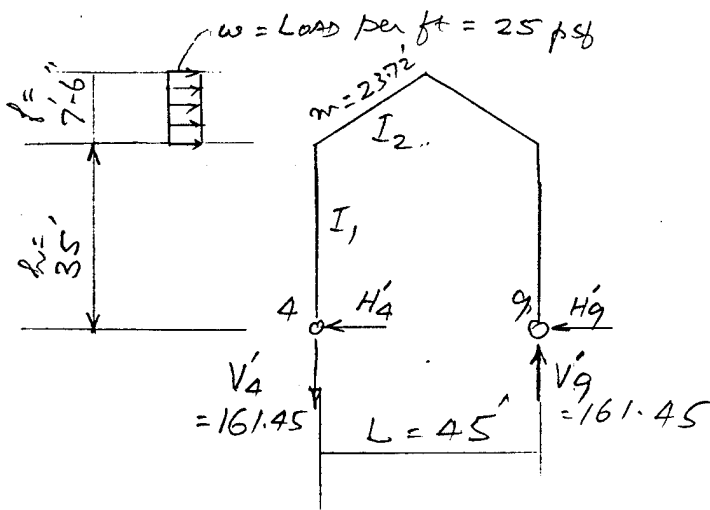

$$V'_4 = V'_9 = V' = \frac{wf(2h+f)}{2l} = \frac{25 \times 7.5 (2 \times 35 + 7.5)}{2 \times 45}$$

$$V' = 161.45 \text{ LB}$$

$$H'_4 = wf - H'_9$$

$$H'_9 = \frac{wf}{4N} (8C + 24 + 20Q + 5Q^2)$$

$$C = \frac{I_2}{I_1} \frac{h}{L} ; \text{ ASSUME } \frac{I_2}{I_1} = 1.$$

$$C = \frac{h}{m} = \frac{35}{23.72} = 1.48$$

OMAHA DISTRICT	COMPUTATION SHEET	CORPS OF ENGINEERS	
PROJECT CERCLA WATER TREAT.	SHEET NO. 12	OF	
ITEM Rocky MTN ARS. CO.	BY OM	DATE	
	CHKD. BY	DATE	

$$Q = \frac{f}{h} = \frac{7.5}{35} = 0.2143$$

$$N = 4(C + 3 + 3Q + Q^2) = 4(1.48 + 3 + 3 \times 0.2143 + 0.2143^2)$$

$$N = 4 \times 5.1703 = 20.68$$

$$H'_B = \frac{25(7.5)}{4 \times 20.68} (8 \times 1.48 + 24 + 20 \times 0.2143 + 5 \times 0.2143^2)$$

$$H'_B = 2.2667(40.36) = 91.47 \text{ LBS}$$

$$H'_A = wf - H'_B = 25 \times 7.5 - 91.47 = 96.03 \text{ LBS}$$

PROJECT CERCLA WATER TREAT. ROCKY MTN.

SHEET NO. 13 OF

ITEM ARS COLORADO

BY OM

DATE

CHKD. BY

DATE

DEAD LOAD UNIFORMLY DISTRIBUTED VERTICAL LOAD
ENTIRE SPAN

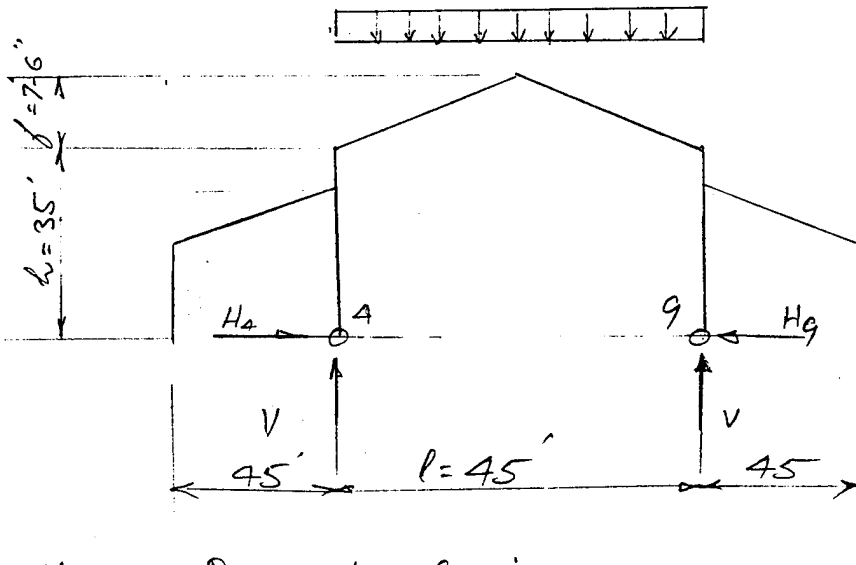

METAL ROOF + INSULATION = 4 psf

MISC. EQUIP. = 4

RAFTER & PURLINS = 5

13 SAY 15 psf

$w = 15 \text{ psf}$

$V_a = V_g = 15 \times 22.5 = 337.5 \text{ lbs}$

$Q = 0.2143$

$N = 20.68$

$H = H_a = H_g = \frac{wl^2}{8hN} (8 + 5Q) = \frac{15(45)^2}{8 \times 35 \times 20.68} (8 + 5 \times 0.2143)$

$H = 47.59 \text{ LBS}$

PROJECT CERCLA WATER TREATMENT - ROCKY

SHEET NO. 14 OF

ITEM

MTN. ARS. COLORADO

BY OM

DATE

CHKD. BY

DATE

DEAD LOADS (CONT)

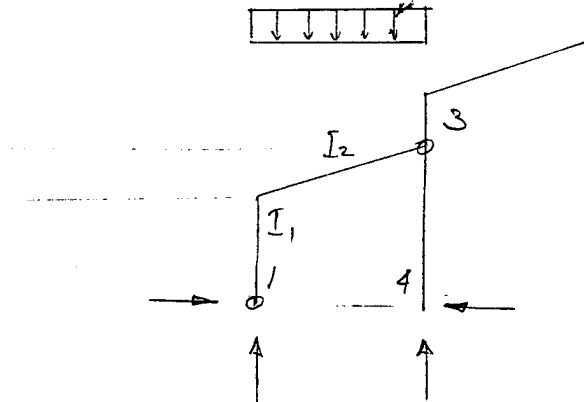
 $w = 15 \text{ plf}$ 

$$M_2 = \frac{wL^2}{8(C+1)} = \frac{wL^2}{8\left(\frac{h}{L}+1\right)}$$

$$= \frac{15(45)^2}{8 \times \left(\frac{14}{45} + 1\right)}$$

$$C = \frac{I_2}{I_1} \frac{h}{L}$$

ASSUM $I_2 = I_1$

$$C = \frac{h}{L}$$

$$= \frac{30375}{8 \times 1.311} = 2895.92$$

$$H_1 = H_3 = \frac{2895.92}{14} = 206.85 \text{ lbs}$$

$$V_1 = \frac{wL}{2} - \frac{M_2}{L} = \frac{15 \times 45}{2} - \frac{2895.92}{45}$$

$$= 337.5 - 64.35 = 273.15$$

$$V_3 = \frac{wL}{2} + \frac{M_2}{L} = 337.5 + 64.35 = 401.85$$

PROJECT CERCLA WATER TREAT.-

SHEET NO. 15 OF

ITEM ROCKY MTN. CO.

BY OM

DATE

CHKD. BY

DATE

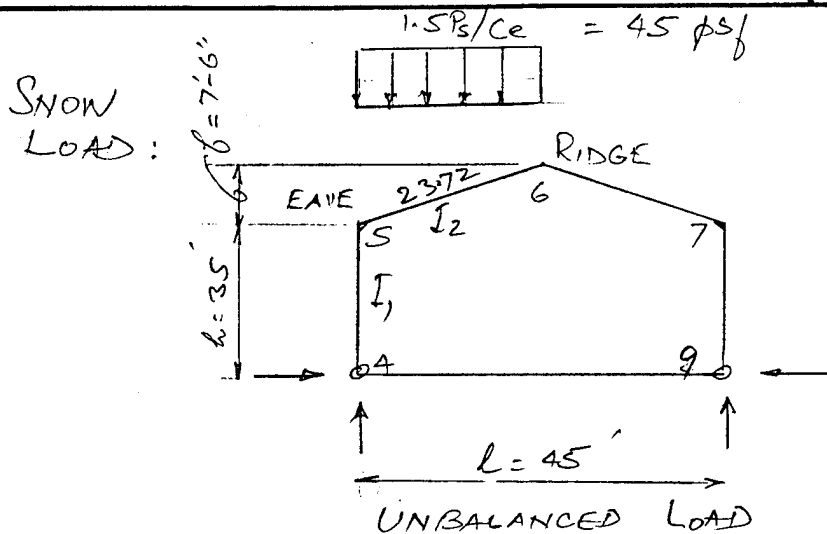

$$V_A = \frac{3wl}{8} = \frac{3 \times 45 \times 45}{8} = 759.4 \text{ LB.}$$

$$V_B = \frac{wl}{8} = \frac{45 \times 45}{8} = 253.1 \text{ LBS.}$$

$$H_A = H_B = H = \frac{wl^2}{16hN} (8 + 5Q)$$

$$Q = \frac{f}{h} = \frac{7.5}{35} = 0.2143$$

$$N = 4(C + 3 + 3Q + Q^2) \quad ; \quad C = \frac{I_2}{I_1} \frac{h}{m} = \frac{h}{m}$$

$$N = 4\left(\frac{35}{23.72} + 3 + 3 \times 0.2143 + 0.2143^2\right) \quad \text{Assume } I_2 = I_1$$

$$N = 8.83$$

$$H_A = H_B = \frac{45 \times (45)^2}{16 \times 35 \times 8.83} (8 + 5 \times 0.2143)$$

$$= 167.1 \text{ LBS.}$$

OMAHA DISTRICT	COMPUTATION SHEET	CORPS OF ENGINEERS	
PROJECT CERCLA WATER TREAT. ROCKY MTN.	SHEET NO. 16	OF	
ITEM	ARS. Co.	BY OM	DATE
		CHKD. BY	DATE

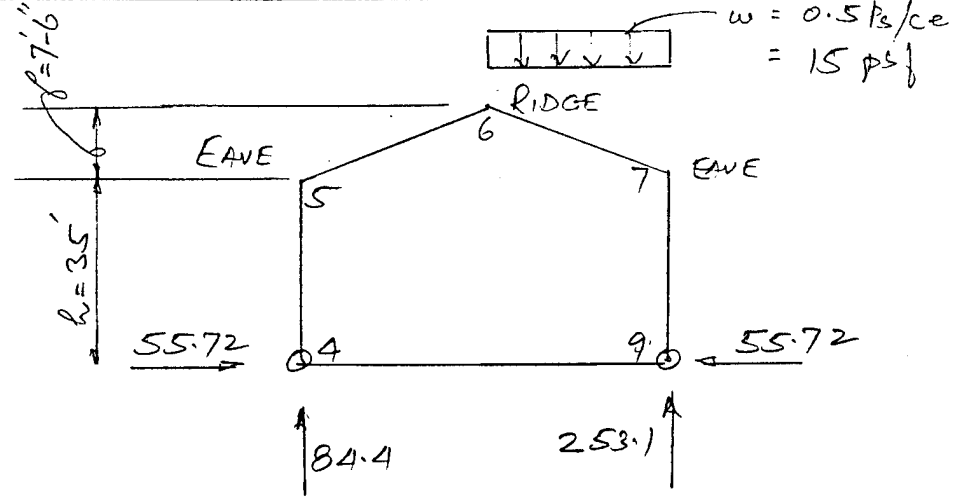

$$V_4 = \frac{wl}{8} = \frac{15 \times 45}{8} = 84.4 \quad \text{LB}$$

$$V_8 = \frac{3wl}{8} = \frac{3 \times 15 \times 45}{8} = 253.1 \quad \text{LB}$$

$$H_A = H_B = H = \frac{wl^2}{16hN} (8 + 5Q)$$

$$N = 8.83 ; Q = 0.2143$$

$$H_A = H_B = H = \frac{15 \times (45)^2}{16 \times 35 \times 8.83} (8 + 5 \times 0.2143)$$

$$= 55.72$$

PROJECT CERCLA WATER TREAT.

SHEET NO. 18 OF

ITEM ROCKY MTN ARS. CO.

BY OM

DATE

CHKD. BY

DATE

CASE II D+W

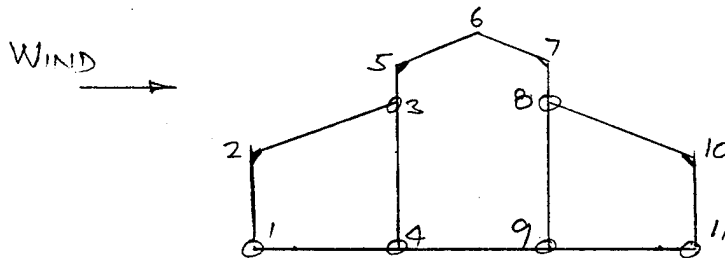

VERT. REACTION \uparrow

DUE TO

DEAD LOADS	+ 273	+ 402	+ 402	+ 273
		+ 338	+ 338	

DUE TO WIND LOAD

+ 0.2	- 0.2	+ 0.2	
- 179	- 234	+ 234	
	- 161	+ 161	

<u>+ 94.2</u>	<u>+ 345</u>	<u>+ 1135.2</u>	x 17'-6"
---------------	--------------	-----------------	----------

HORIZ. REACTION \rightarrow

DUE TO DEAD LOADS	+ 207	- 207	+ 207	- 207
-------------------	-------	-------	-------	-------

+ 48	- 48		
------	------	--	--

DUE TO WIND	- 174	- 137	- 226	
	- 188	- 96	- 91	

<u>- 155</u>	<u>- 392</u>	<u>- 158</u>	x 17'-6"
--------------	--------------	--------------	----------

OMAHA DISTRICT	COMPUTATION SHEET	CORPS OF ENGINEERS	
PROJECT CERCLA WATER TREATMENT	SHEET NO. 19	OF 19	
ITEM Rocky Mtn. Ars. Colorado	BY OM	DATE 6/29/90	
	CHKD. BY	DATE	

TO CALCULATE SIZE OF FOOTING
 USE EXCESS SOIL BEARING
 PRESSURE = 2000 PSF
 INTER COLUMNS
 EXTERIOR SIDE WALLS

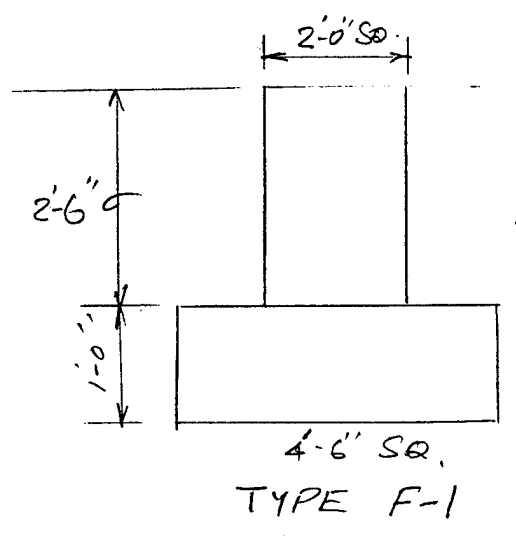
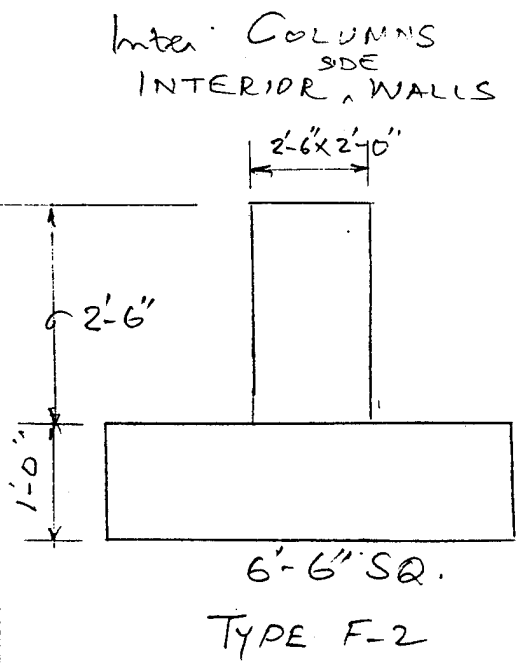

EXTERIOR CORNER COLUMNS

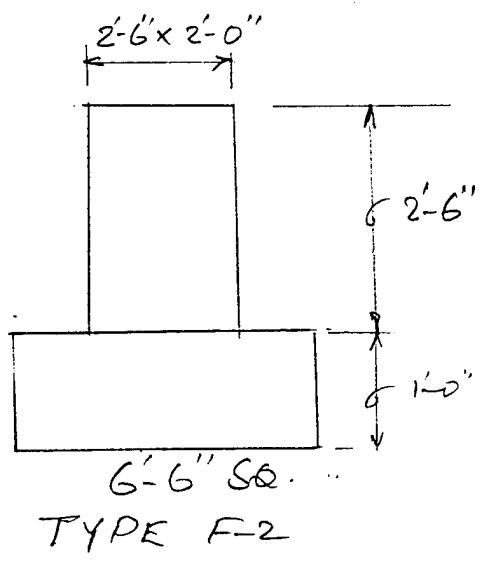

INTERIOR COLUMNS
 EXTERIOR END WALLS

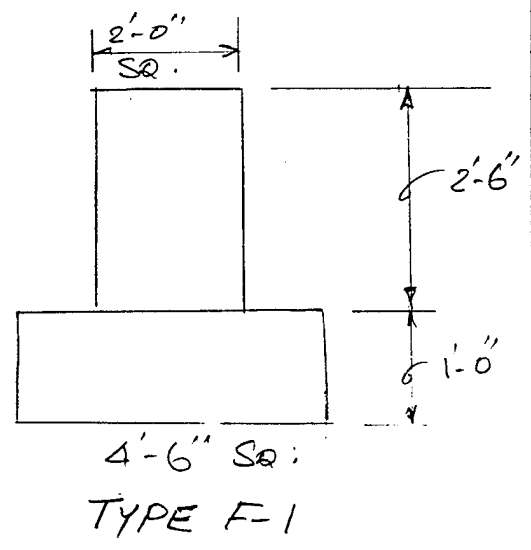

UPLIFT DOES NOT CONTROL.

ATTACHMENT D
ELECTRICAL CALCULATIONS

US ARMY
CORPS OF ENGINEERS
OMAHA, NEBRASKA

PROJECT: CERCLA
CLIENT:
DATE: 03-26-90

ESD INC. LIGHTING PROGRAM

DESIGNER: M. CARLSON

GENERAL PROJECT INFORMATION:

PROJECT LOCATION: Rocky Mtn. Arsenal
DEFAULT HEIGHT OF CEILING CAVITY: 0.00
DEFAULT HEIGHT OF ROOM CAVITY: 0.00
DEFAULT HEIGHT OF FLOOR CAVITY: 2.50
DEFAULT PERCENT CEILING REFLECTANCE: 50
DEFAULT PERCENT WALL REFLECTANCE: 20
DEFAULT PERCENT FLOOR REFLECTANCE: 20
DEFAULT DIRT DEPRECIATION FACTOR: 78

FIXTURE SCHEDULE REPORT FORMAT:

```

*****
ORDER   FIXTURE NO.  FIXTURE TYPE **  ORDER   FIXTURE NO.  FIXTURE TYPE
*****
1       0           **      21      0
2       0           **      22      0
3       0           **      23      0
4       0           **      24      0
5       0           **      25      0
6       0           **      26      0
7       0           **      27      0
8       0           **      28      0
9       0           **      29      0
10      0           **      30      0
11      0           **      31      0
12      0           **      32      0
13      0           **      33      0
14      0           **      34      0
15      0           **      35      0
16      0           **      36      0
17      0           **      37      0
18      0           **      38      0
19      0           **      39      0
20      0           **      40      0

```

***** LIGHTING FIXTURE CALCULATIONS BY ELITE SOFTWARE DEVELOPMENT INC *****
 US ARMY OMAHA, NEBRASKA
 CERCLA 03-26-90 PAGE 2
 ***** FIXTURE REQUIREMENTS REPORT *****

ROOM NO. AND NAME	#TIMES	HCC	HRC	HFC	LLD	S/MH.	LUMEN	D-FC.
FIX. DESCRIPTION	LENGTH	CCR	RCR	FCR	LDD	#F/ROW	#LAMP	D-FIX
FIX. MANUFACTURER	WIDTH	PC	PW	PF	TBF	# ROWS	WATTS	I-FIX
FIX. CATALOG NO.	AREA	PCC	PFC	PFM	LLF	COEF.U	W/SF.	I-FC.
Office	1	0.00	7.50	2.50	95	1.20	11400	50.00
TYPE 206C GRID TROFF	19.00	0.00	4.86	1.62	78	2	4	4.88
IES LIGHTING HANDBK	13.00	50.00	20.00	20.00	100	2.50	1000	5.00
IES #41	247.00	50.00	13.84	0.991	74	30.21	4.05	51.20
Bathroom	1	0.00	7.50	2.50	95	1.20	5700	20.00
TYPE 206A GRID TROFF	7.00	0.00	12.86	4.29	78	1	2	%-999
IES LIGHTING HANDBK	5.00	50.00	20.00	20.00	100	1.00	100	1.00
IES #41	35.00	50.00	8.71	0.993	74	* 17.00	2.86	20.38
Closet	1	0.00	7.50	2.50	95	1.20	5700	15.00
TYPE 206A GRID TROFF	6.00	0.00	13.75	4.58	78	1	2	%-999
IES LIGHTING HANDBK	5.00	50.00	20.00	20.00	100	1.00	100	1.00
IES #41	30.00	50.00	8.35	0.993	74	* 17.00	3.33	23.77
Storage Room	1	0.00	7.50	2.50	95	1.20	11400	15.00
TYPE 206C GRID TROFF	13.00	0.00	7.57	2.52	78	1	4	%-999
IES LIGHTING HANDBK	8.00	50.00	20.00	20.00	100	1.00	200	1.00
IES #41	104.00	50.00	11.63	0.993	74	21.07	1.92	16.99
Process Room	1	6.00	9.50	2.50	95	1.80	14400	25.00
TYPE 302B (150 WATT)	60.00	1.65	2.62	0.69	78	2	1	7.10
IES LIGHTING HANDBK	26.00	50.00	20.00	20.00	100	4.00	1440	8.00
IES #21	1560.00	31.32	16.90	0.995	74	51.75	0.92	28.17
Process Room	1	6.00	9.50	2.50	95	1.80	14400	25.00
TYPE 302B (150 WATT)	26.00	3.30	5.22	1.37	78	1	1	2.42
IES LIGHTING HANDBK	14.00	50.00	20.00	20.00	100	3.00	540	3.00
IES #21	364.00	20.82	14.56	0.996	74	35.33	1.48	30.95
Sludge Storage	1	0.00	5.50	2.50	70	1.50	5700	20.00
TYPES 230Aa & 230A1a	6.00	0.00	11.46	5.21	78	1	2	%-999
IES LIGHTING HANDBK	4.00	50.00	20.00	20.00	90	1.00	100	1.00
IES #25	24.00	50.00	7.68	0.993	49	* 21.00	4.17	24.33