

SDTIC
ELECTE
JAN 23 1995
c D



US Army Corps
of Engineers
Waterways Experiment
Station

THE **REMR**
19960117 075 **BULLETIN**

VOLUME 12, NUMBER 3

OCTOBER 1995

NEWS FROM THE REPAIR, EVALUATION, MAINTENANCE, AND REHABILITATION RESEARCH PROGRAM

Precast concrete panels used to rehabilitate Allegheny River Lock and Dam No. 4

by Carmen Rozzi, U.S. Army Engineer District, Pittsburgh

DISTRIBUTION STATEMENT A

Approved for public release
Distribution Unlimited

The use of precast concrete panels proved to be time saving and cost effective during recent repairs to the Allegheny River Lock and Dam No. 4. Encouraged by the constructibility of the system, the contractor was able to place an average of 18 panels in an 11-hr work shift. The design of the precast panels incorporated details as outlined in Technical Reports REMR-CS-7 (ABAM Engineering, Inc. 1987) and REMR-CS-41 (Miles and Bergman 1993).

Constructed between the early to mid-1920's, the lock has been in operation since 1927. Typical of this time period, the concrete is nonair-entrained and is therefore more susceptible to cycles of freezing and thawing and weathering damage. Major repairs to the lock walls in 1966 used conventional cast-in-place concrete and shotcrete methods. These repairs have not fared well.

Located 24.2 miles upstream of Pittsburgh, PA, the lock consists of a single 56- by 360-ft lock chamber. The

land and river walls are standard monolithic concrete gravity structures founded on bedrock. The top of the lock walls are at elevation (el) 757.5. The lock chamber has a 10.6-ft lift with upper pool el 745.4 and lower pool el 734.8. The unpaved, irregular chamber floor conforms to the existing bedrock profile. The mean chamber floor elevation is approximately 723.5.

In 1988 a condition survey was performed under the direction of the U.S. Army Engineer Waterways Experiment Station (WES). The study determined that vertical wall repair should be included as part of any future rehabilitation work. The Ohio River Division (ORD) suggested the use of precast concrete panels for this wall repair. With these recommendations, the Pittsburgh District allocated E&D funding for preparation of plans and specifications in FY 93 and 94.

Operational Considerations

Navigation concerns did not want the lock closed for more than 30 days, nor could the closure period begin before October 25 since fall foliage riverboat tours are popular on the Allegheny. Due

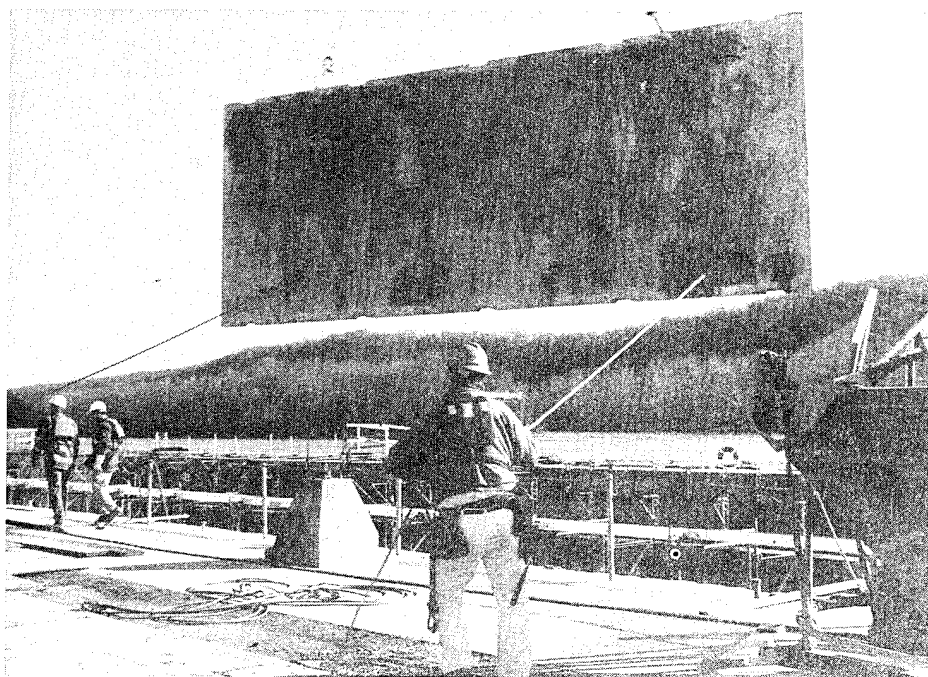

Precast panel being lowered into place during rehabilitation of Allegheny River Lock and Dam No. 4



to the amount of work to be accomplished, two lock closure periods were established, the first being October 25 to December 3, 1994 (a 40-calendar day closure period), and the second scheduled for September 6 to October 3, 1995 (a 28-calendar day closure period).

The precast concrete panels were to be installed during the first closure period so that the contractor could proceed with other contractual work. The District repair party fleet was scheduled to set upstream and downstream needle dam closures, set bulkheads, close and secure the 16 filling and emptying valves of the river wall, and perform initial drawdown (dewatering) of the chamber.

Design Considerations

The first monoliths within the chamber at the upstream and downstream extent contained ladder recess and line hook assemblies that were to be replaced by means of conventional cast-in-place concrete repair methods. At the center of the chamber, one monolith had a ladder and line hook assembly that was also detailed for conventional cast-in-place concrete for half the monolith and a precast panel for the other half of the monolith. A total of 14 full monoliths and 3 half monoliths were refaced with the precast concrete panels. The height of the repair was set between an elevation corresponding to 2 ft below lower pool and top of lock wall elevation.

The typical monolith length for this lock is 36 ft with one monolith being 40 ft long. With the top of wall at el 757.5 and lower repair elevation at 732.8, a repair height of 24.7 ft was required. Three rows of 8- and 7-ft panel heights were detailed for the river and land walls, respectively.

The overall length of each monolith was divided in half to provide one standard 18-ft panel and one +/-18-ft panel. Some odd-dimensioned panels were detailed at irregular-sized areas. A total of 45 panels (three rows of 15 panels) were required for the river wall, and 48 panels (three rows of 16 panels) were required for the land wall.

The design, based upon a maximum 8-ft-wide by 20-ft-long by 6.5-ft-thick panel size, was performed according to Appendix A, "Alternate Design Method" of the American Concrete Institute

Building Code Requirements for Reinforced Concrete (ACI 318-89) (ACI, 1993). Allowable working stresses were in accordance with Engineer Manual 1110-1-2101, "Working Stresses for Structural Design" (Headquarters, Department of the Army 1963). Design criteria as set by the Precast/Prestressed Concrete Institute (PCI) Design Handbook, *Precast and Prestressed Concrete* (1992) were used for handling other pertinent design requirements.

Construction service loading was to be produced by two 4-ft-high lifts of infill concrete placed behind the panels and handling loads. The handling loads analyzed included (a) those produced by stripping from forms, (b) loads caused by handling and storage of panels at the place of fabrication and at the project site, (c) loads expected to occur during shipment to the site, and (d) loads occurring during erection. The contract required that all loading and handling conditions be analyzed by the contractor and submitted for approval. Handling details were to be submitted with the shop drawings for approval.

Limiting crack propagation was a controlling aspect for reinforcing requirements. Crack widths were limited through acceptance criteria stipulated within the contract requirement by specifying an allowable crack width of 0.005 in. for design. The Gergely-Lutz equation as defined by the ACI Code was the controlling criterion.

The main reinforcing steel was placed at a 2-in.-clear depth from the exterior face of the panel. A reinforcing mat of No. 5 bars at 6 in. on centers each way was required by the design. An additional mat of No. 5 bars at 12 in. on centers each way was detailed at a 3/4-in.-clear depth from the interior face of the panel to handle tension stresses developed by handling operations. The interior face of the panel had a raked finish to enhance bonding with the infill concrete.

Embedded metal hardware was designed as detailed in Technical Report REMR-CS-7. A 1- by 6-in. recess was detailed at the top and bottom of the panels to allow for the form anchor bars. A 1-ft taper was detailed at all panel-to-panel joints. The taper narrowed to a 5-1/2-in. panel thickness at the ends to mitigate barge impact at potential panel misalignment points. Lifting hardware locations and maximum weight requirements were

specified. The responsibility for actual hardware structural integrity rested with the precast panel fabricator.

The precast panels were designed for a four-point lift, two points positioned longitudinally and transversely to produce both equal positive and negative moments. For no discernible cracking, flexural tensile stresses were limited by Equation 5.2.1 of the PCI Design Handbook. All factors of safety as designated by the handbook were employed.

The compressive strength for the precast concrete panels was set at 6,500 psi. The water-cement ratio (w/c) was limited to 0.40. Cement content, pozzolan content, and all other criteria were to be selected in accordance with the applicable provisions of the ACI Code or the PCI Design Handbook. American Society for Testing and Materials (ASTM) C 150, Type II cement was specified. Grade 60 deformed bars were used for reinforcing steel, conforming to ASTM A 615; A 616, including supplementary requirement S1; or A 617.

The compressive strength for the infill concrete was set at 4,000 psi. A sample mixture specified a nominal maximum aggregate size of 3/4 in. (19.0 mm), a w/c of 0.37, and an air content of 7 percent. The mixture was not bound by any other specific limitations other than meeting the 4,000-psi compressive strength criterion.

Construction Considerations

Concrete removal was limited to a 12-in. depth from the face of the lock wall. Concrete removal by explosive methods was permitted for all monoliths except the four gate-recess monoliths. The contract required that all line drilling and other miscellaneous prerequisite work be completed prior to the first lock closure date of October 25, 1994.

The specifications for line drilling required the holes to be a minimum of 2 in. in diameter and spaced 12 in. on center. The holes were to be drilled to the repair elevation of 732.8 with equipment competent enough to maintain alignment. A saw cut of 12 in. at the bottom of the repair area was specified to produce a clean a break as possible. Repair of any overbreak from

the presplitting operation was also detailed.

The presplitting to be performed used a maximum charge of 100 grains per foot Primacord, and stemming of the entire hole was specified. Vibration monitoring of all blasts was also required.

The specifications required that the contractor place at least the lower two rows of all panels within the first lock closure period, and the top row of panels if possible.

Project Execution

Contract award

The contract was awarded on June 21, 1994, to Mosites Construction Company, Pittsburgh, PA. The Notice to Proceed was issued July 10, 1994. The first set of shop drawing submittals for precast panel details and design was required by contract 11 days thereafter. The Fort Miller Company of Schuylerville, NY, was subcontracted to fabricate the precast concrete panels. This same company was the fabricator of the precast panels for the lock wall rehabilitation described in Technical Report REMR-CS-41.

The general contractor requested a variance to detail a precast panel anchorage system as outlined in the above-mentioned REMR report. The variance was adopted, and design features of the precast system were modified during the shop-drawing review phase in order to expedite the process. The major features of the variance involved revisions of joint and lock-wall anchorage details.

Design modifications

With the elimination of the miscellaneous metal embedments as originally detailed in the contract design, the tops and bottoms of the precast panels were now flush. Therefore, to transfer load from panel to panel and from panel to bearing ledge, it was necessary to design and detail a bearing plate. Each panel required two bearing plates placed at the equal-moment positions. The bottom bearing-ledge plate design required a minimum of 4- by 12-in. bearing plate and 4- by 9-in. panel-to-panel bearing plate. A 1-in. horizontal and vertical joint was detailed.

With a 1-in.-horizontal-joint requirement, the contractor opted to use

a plastic material for the bearing plates. These bearing plates were supplied in varying thicknesses, were able to be stacked one on top of the other, and became shimpacks used to make up construction tolerances (Figure 1). Additional horizontal-joint filler material was required to fill the void and also withhold the infill concrete-placement pressures. A closed-cell synthetic-foam material was chosen. The material was supplied in 1-1/2-in. thicknesses, was highly compressible, adhered to the

concrete surface, and was easily cut to accommodate the shimpack bearing plates (Figure 1).

The approved shop-drawing detail provided a shear key on the interior face of the panel, allowing the infill concrete to penetrate the vertical-panel joint. A backer rod was placed at the face with the required spacing allotted for joint-sealant material (Figure 2). The panel-to-panel monolith joint detailed a 3/4-in. bituminous expansion material with joint sealant on the exterior. This

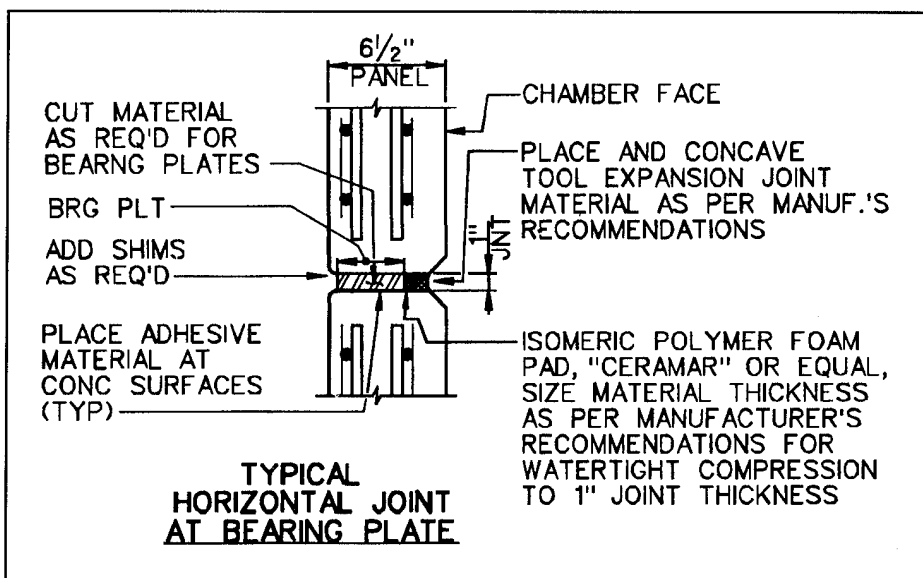

Figure 1. Schematic of horizontal panel joint with bearing plate

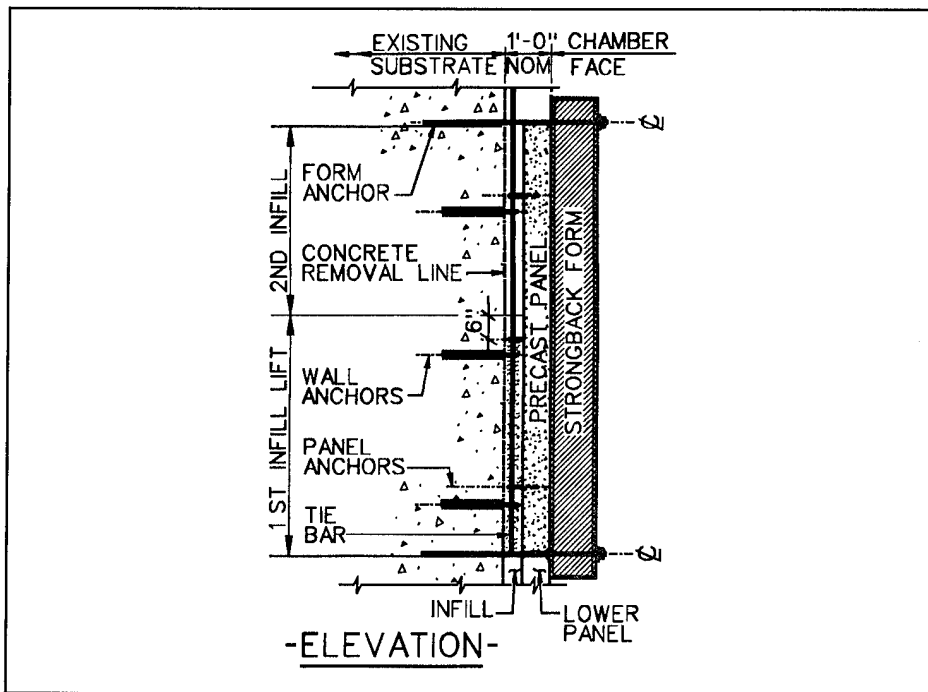

Figure 2. Temporary anchorage system

material was placed full depth to the concrete-removal limits. This detail did not require modification.

With the acceptance of the variance from the original design, a temporary strongback forming system was now required to support the precast panels during infill concrete placement. Also, a permanent system of anchorage was required. Strongbacks were double channel-braced members placed 4 ft center to center. An all-thread form anchor pinned the strongbacks in place at the top and bottoms of the panels (Figure 2).

The permanent anchorage consisted of Technical Report REMR-CS-41 details. A bent 180-deg reinforcing bar (panel anchor) was embedded into the back face of the panels at an approximate 4-ft grid system to be slightly offset with 90-deg hook number 6 (wall anchors) dowels embedded into the lock wall. A number 5 (tie bar) reinforcing bar was then threaded between the panel anchor and the wall anchor (Figure 3).

Prerequisite work

The contractor overcompensated for the concrete dental-work removal by overdrilling the presplit line. The holes were placed approximately 16 in. from the face of the wall. The saw-cutting operation was subcontracted to two separate contractors, one for the river wall and another for the land wall. Both contractors performed well, and the operation was completed within 24 hr.

The required blast with the specified charge of 100 grains per foot Primacord and stemming of the entire hole did not perform to expectations. Partnering efforts modified the blasting requirements. The bottom 10 ft was to be 125 grains per foot, and the remainder of the hole at 100 grains per foot with the top 5 ft stemmed. Stemming of the entire hole caused excessive velocities in adjacent monoliths.

Dental-preparation work was performed with handheld chipping tools at the bearing-ledge area. A track-mounted rotary-head concrete grinder was used on the lock walls. All overbreak areas at the bearing ledge

were neatly cut to a 2-in.-minimum removal depth. A high-strength grout material was used to repair these areas. Several areas of unsound concrete below the repair area were removed and replaced with a conventional cast-in-place concrete repair.

Scaffolding was placed along both chamber faces of the lock walls maintaining an outriggers (2-ft) distance from the new face of wall. This enabled free movement around all areas of the jobsite during panel placement.

The survey layout of anchor bars for both permanent and temporary threaded bars and dowels was critical. Layout of wall dowels had to precisely match the approved shop-drawing layout for proper alignment of panel anchors and wall anchors for the tie bar to be placed.

The fabrication techniques used by the Fort Miller Company for construction of the precast panels were as outlined in Technical Report REMR-CS-41 except a control joint detailed at the center of the panel was added. Observations of a distinct pattern of cracking located at the center of the panels at Troy Lock led to this addition (Figure 4).

Stripping from forms

The minimum stripping strength was required by contract to be 80 percent of the design strength. A variance was allowed on stripping strength. The fabricator's design analysis demonstrated that a minimum stripping strength of 1,000 psi was required to meet cracking criteria. Obtaining a 3,500-psi initial strength, the panels were stripped in 24 hr after placement. Strength tests for the above mixture were submitted.

Yard and onsite handling and storage

The panels were handled in the field maintaining the horizontal stripping position of the four-point lift. The panels were also stored in the horizontal position with continuous bearing in the transverse dimension located at the pick points producing equal positive and negative moments. The fabricator and contractor employed this same method. Care was taken by both parties to assure the panels were stored in a manner that would not induce undue stresses and cause cracks to develop.

The contractor fabricated a rectangular jib-beam assembly that maintained a 90-deg angle at the pick

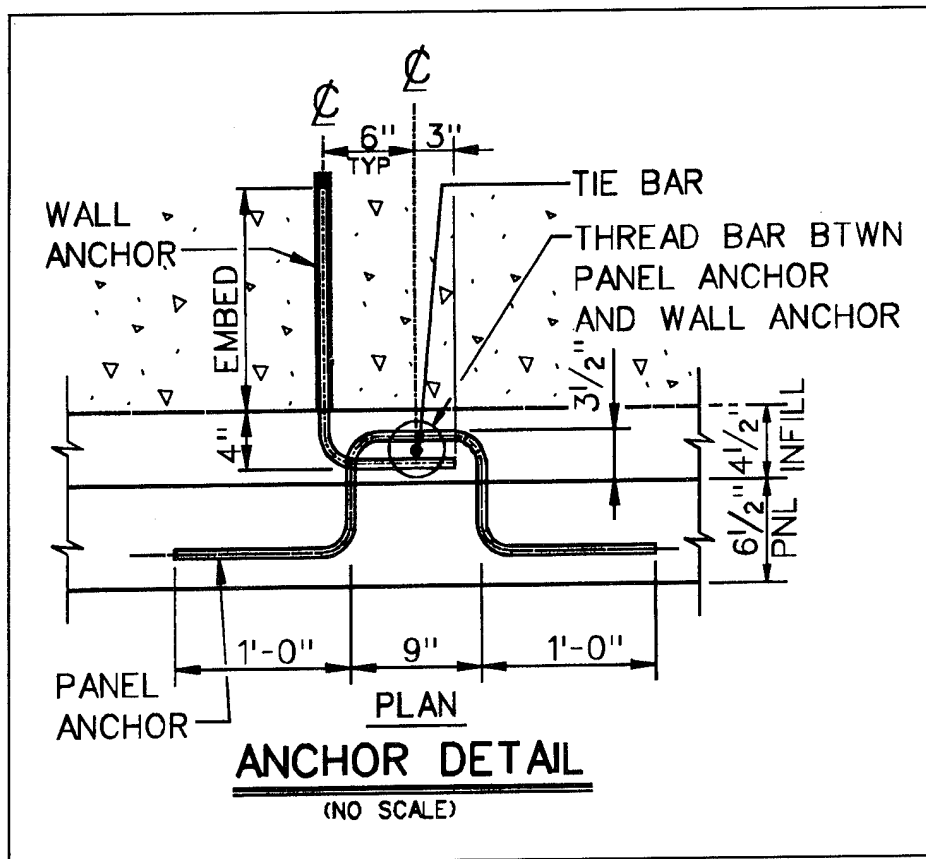

Figure 3. Permanent anchorage system

points, therefore reducing any unnecessary stresses induced by the crane lift lines (Figure 5). Steel-frame I-beam "horses" were also constructed to place the panels on at the storage site for quality-control conformance measures (Figure 6).

The fabrication yard was located in upstate New York, and the panels had to be shipped by flat-bed truck. Since each panel weighed approximately 6 tons, each truck transported only five panels per trip to maintain weight limits on highways. An average trip took approximately 12 hr with load. The panels were placed in a horizontal position with a continuous two-point bearing in the transverse dimension. The panels were stacked three high with wooden dunnage and cushion pads separating each of them.

Because space was limited at the project site, a storage area was procured approximately 1 mile from the project. The panels were transported by flat-bed truck at the time the specific panel was required for placement. At the project site, the panels were placed on a bed of tires prior to tilt-up. With crane-lifting lines secured at two lifting points at the top of the panel and continuous bearing at the bottom, panels were tilted into the vertical position.

Panel placement

The contractor worked two 11-hr shifts. The day shift placed the precast panels and infill concrete. The night shift placed the strongback forming system and performed all necessary fine tuning for vertical and horizontal alignment.

The bearing plates were positioned as detailed. Elevations were then taken, and shim bearing plates added or subtracted for level. After these plates were in position and properly leveled, holes were cut in the expansion-joint filler material at the shimpack bearing-plate locations and then placed. An adhesive material was placed on the concrete surfaces prior to joint filler-material placement. The adhesive secured the joint materials for infill concrete placement.

Two 140-ton-capacity cranes were located, one upstream and one downstream of the land-wall powerhouse. Each crane had a reach of approximately 60 ft to maximum placement. The panels were lowered into place and temporarily attached at

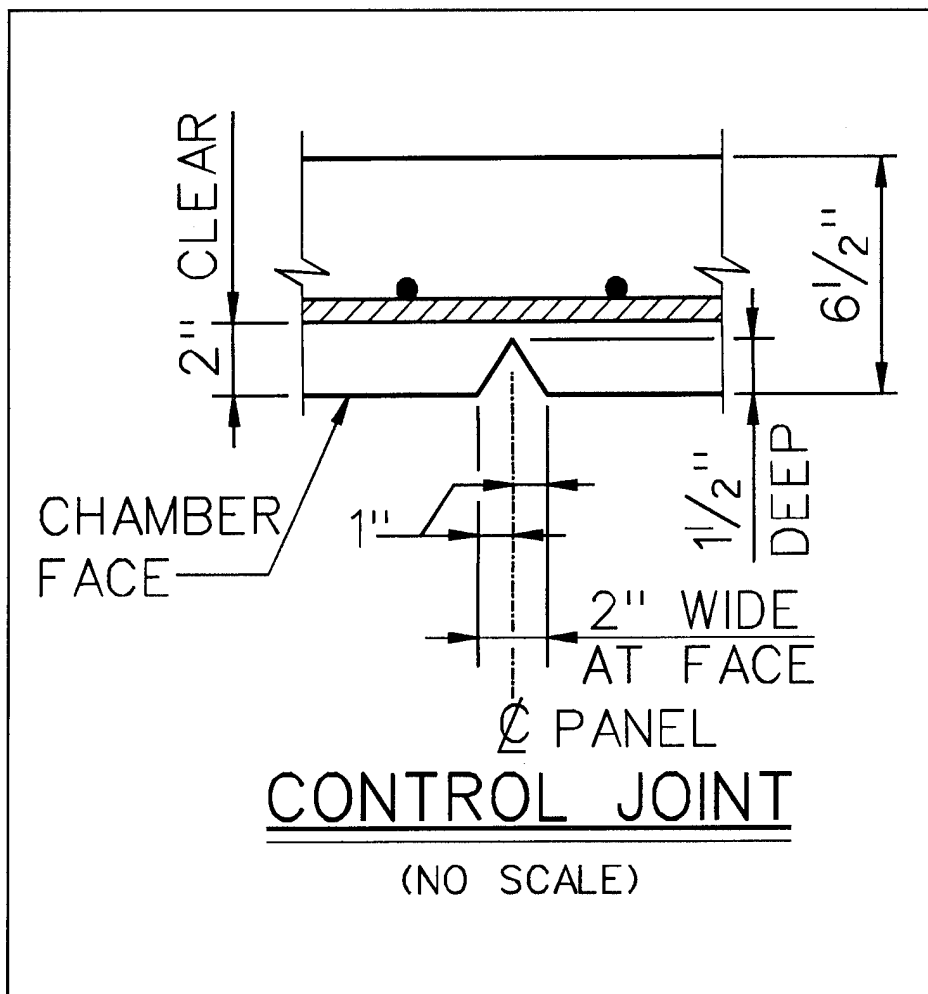

Figure 4. Control joint added at center of panel

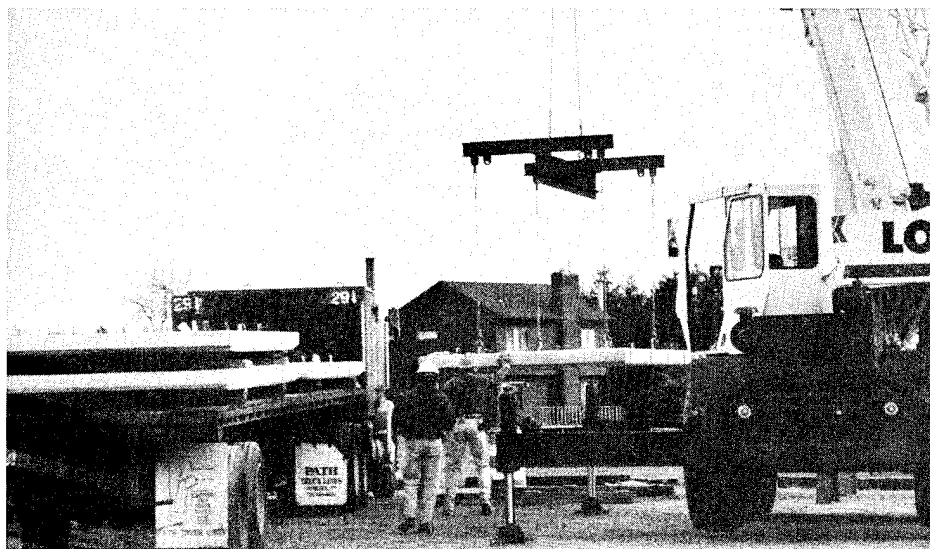

Figure 5. Contractor's jib-beam assembly used during onsite handling

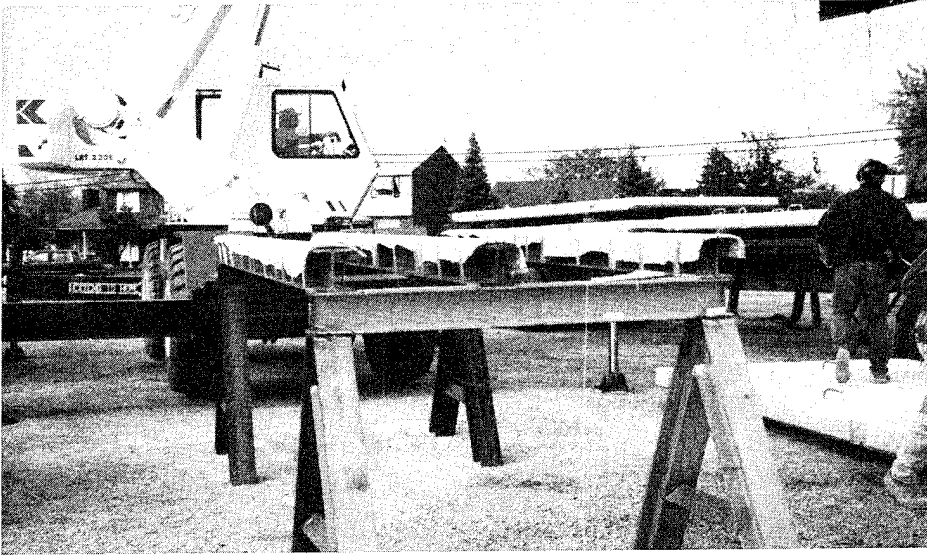

Figure 6. Steel-frame I-beam horses, used for quality-control measurements

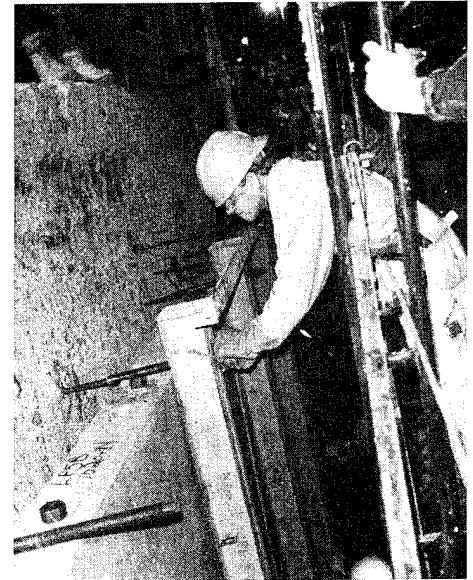

Figure 7. Temporary strongback forming system

the top center of the panel with a fabricated metal bracket. The tie bar was then threaded through the panel anchors and the wall anchors. They were then vertically aligned with bolts threaded through ferrule-loop embedded inserts at the four corners.

The strongback forming system consisted of double channels welded together by bracing (Figure 7). For continuity at panel-to-panel locations, two strongback channels were framed together to span the panel joints. The interior strongbacks were framed together. The strongback forming system was then placed. Additional fine tuning of the vertical and horizontal alignment was performed. Construction string lines were used as reference for alignment.

Infill concrete was placed with flexible tremie tubes (elephant trunk) (Figure 8). A concrete bucket lifted by the erection crane was used to distribute the infill concrete.

The first couple of days of panel placement was a learning period. After the contractor was comfortable in his placement procedures, the pace picked up. The following is a brief summary of panel placement progress:

- 1st day of panel placement:
(8 Nov 94) - 6 panels
- 2nd day of panel placement:
(9 Nov 94) - 9 panels
- 3rd day of panel placement:
(12 Nov 94) - 19 panels
- 4th day of panel placement:
(14 Nov 94) - 19 panels

- 5th day of panel placement:
(15 Nov 94) - 19 panels
- 6th day of panel placement:
(17 Nov 94) - 18 panels
- Total - 90 panels

Panel performance

Of the 90 panels, one had two noticeable hairline cracks starting at the top upstream half of the panel and traversing the face to the center portion of the panel. These cracks were noted prior to panel placement. The top panel at the upstream-most portion of the river wall experienced the same type of cracking. These cracks were noticed after infill concrete placement. The cause might have been due to lack of adequate shimming between the strongbacks and panel face.

Conclusions

The results from the project proved to be above anticipated performance levels. The contractor was pleased with the constructibility aspects of the precast panel repair system and realized that a cast-in-place alternative would have taken much longer. The durability of a higher performance concrete should prove to be beneficial for long-term endurance. The knowledge and experience gained by both the District and the contractor will prove to be beneficial (Figure 9).



Figure 8. Flexible elephant trunk concrete chute

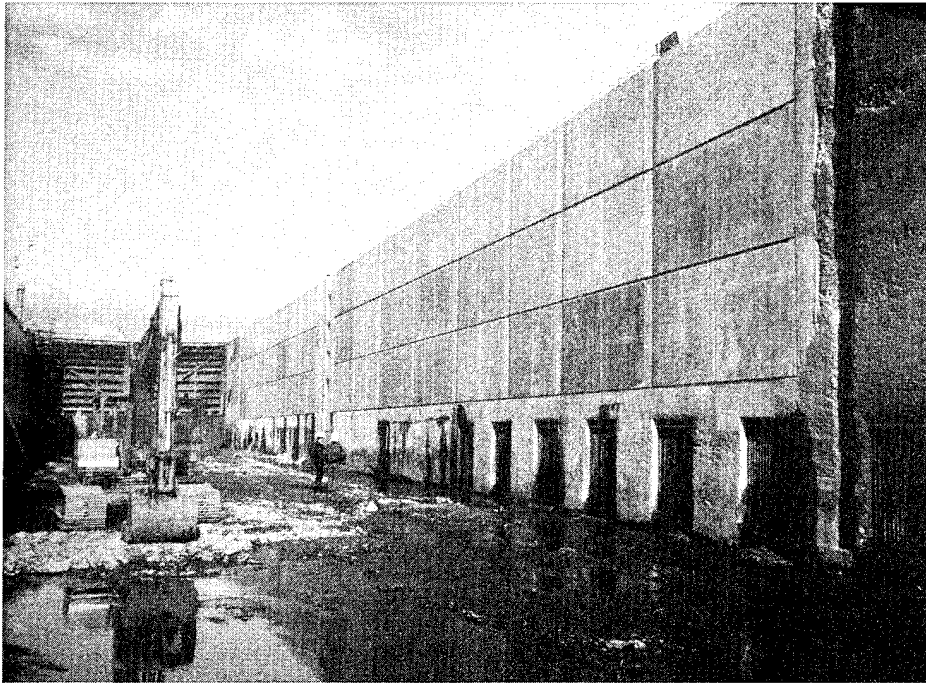
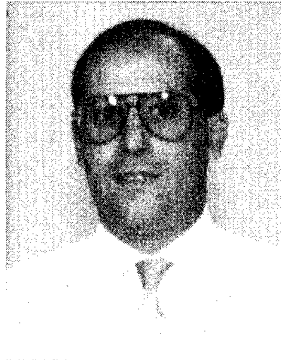

Figure 9. River wall panels, looking upstream

References

- ABAM Engineers, Inc. (1987). "Design of a precast concrete stay-in-place forming system for lock wall rehabilitation," Technical Report REMR-CS-7, U.S. Army Engineer Waterways Experiment Station, Vicksburg, MS.
- ACI. (1993). American Concrete Institute Building Code Requirements for Reinforced Concrete (ACI 318-89) Appendix A, Alternate Design Method, *ACI Manual of Concrete Practice*, Part 3, Detroit, MI.
- Headquarters, Department of the Army. (1963). "Working stresses for structural design," EM 1110-1-2101, Washington, DC.
- Miles, W. R., and Bergman, D. J. (1993). "Comparison of cast-in-place concrete versus precast concrete stay-in-place forming system for lock wall rehabilitation," Technical Report REMR-CS-41, U.S. Army Engineer Waterways Experiment Station, Vicksburg, MS.
- PCI Precast/Prestressed Concrete Institute. (1992). *PCI Design Handbook, Precast and Prestressed Concrete*, Fourth Ed., Manual 120-92, Chicago, IL.

Carmen Rozzi is a civil engineer in the Pittsburgh District's Design branch. He received a B.E. degree in civil engineering from Youngstown State University. At the Pittsburgh District, he is responsible for civil projects pertaining to navigation structures. He has been with the Corps of Engineers since 1989. Rozzi was named the ORD Designer of the Year for this project.



Accession For	
NTIS GRA&I	<input checked="" type="checkbox"/>
DTIC TAB	<input type="checkbox"/>
Unannounced	<input type="checkbox"/>
Justification	
By: <i>[Signature]</i>	
Distribution/	
Availability Codes	
Dist	Avail and/or Special
A-1	

Heaters for alleviating icing on tainter gates

by F. Donald Haynes, Cold Regions Research and Engineering Laboratory

Ice buildup on tainter gates at northern locks and dams can be a serious problem. For example, ice frozen onto the upstream skinplate can prevent movement of the gate and restrict river flow control at the dam. (Sheet ice grown onto the upstream skinplate of a tainter gate at Starved Rock Lock and Dam is shown in Figure 1.) Another difficulty occurs when structural members such as trunnion arms or support channels become coated with ice from submergence in the downstream pool, from splashing, or from the atmosphere.

The additional weight caused by ice buildup on tainter gates can engage the protective switch on the lifting motors and prevent movement of the gates. Heaters positioned at critical locations on the gates can be effectively used to remove ice before movement of the gates is required.

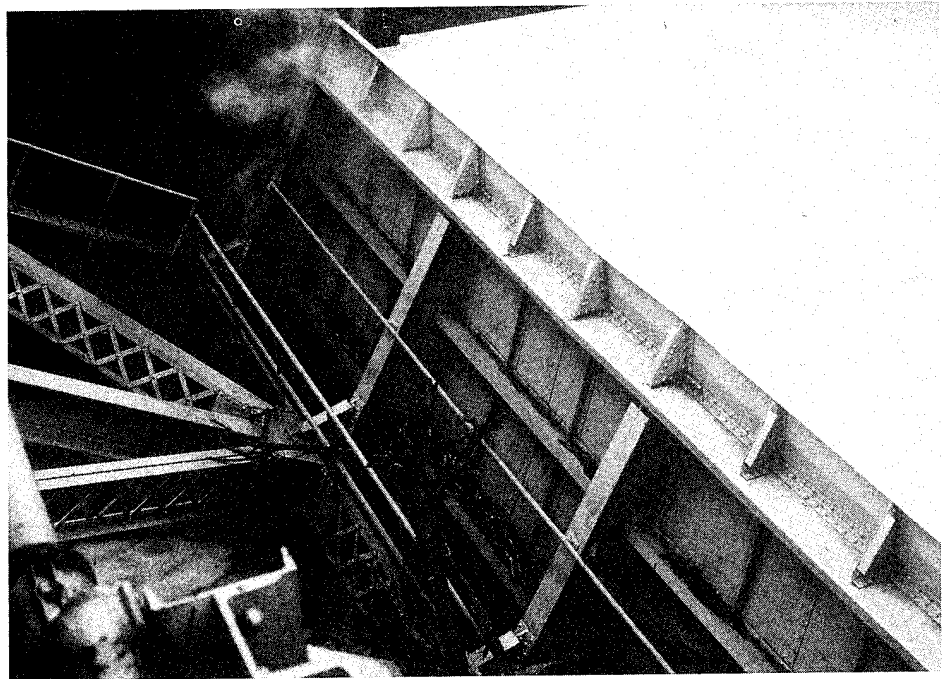

Figure 1. Ice grown onto a tainter gate

Heaters on tainter gates

In the St. Paul District, engineers have designed heaters for tainter gates that can be used to remove ice. Heaters have been placed on four tainter gates at Lock and Dam No. 2 on the Upper Mississippi River. A typical installation is shown in Figure 2. Cartridge heaters have been placed in watertight enclosures on the upstream skinplate. Five enclosures are placed in a heater box with a total heater capacity per foot of gate width of 750 W/ft. When a gate needs to be raised or lowered, the heaters are turned on to melt the sheet ice that grows onto the front of the gate. It typically takes about 2 hr to melt about an inch of ice away from the gate so that it can be moved.

Instead of relying solely on the heaters on the front of the tainter gate at Lock and Dam No. 2, an air diffuser line has been placed under the heater box to assist in distributing the heat more effectively. This diffuser line with eight orifices spaced 4 ft apart is shown in Figure 3. The air diffuser is a 1-in. pipe, and the orifices are 1/8-in. holes drilled in the pipe. On both ends of the diffuser pipe are pipe tees, and one end

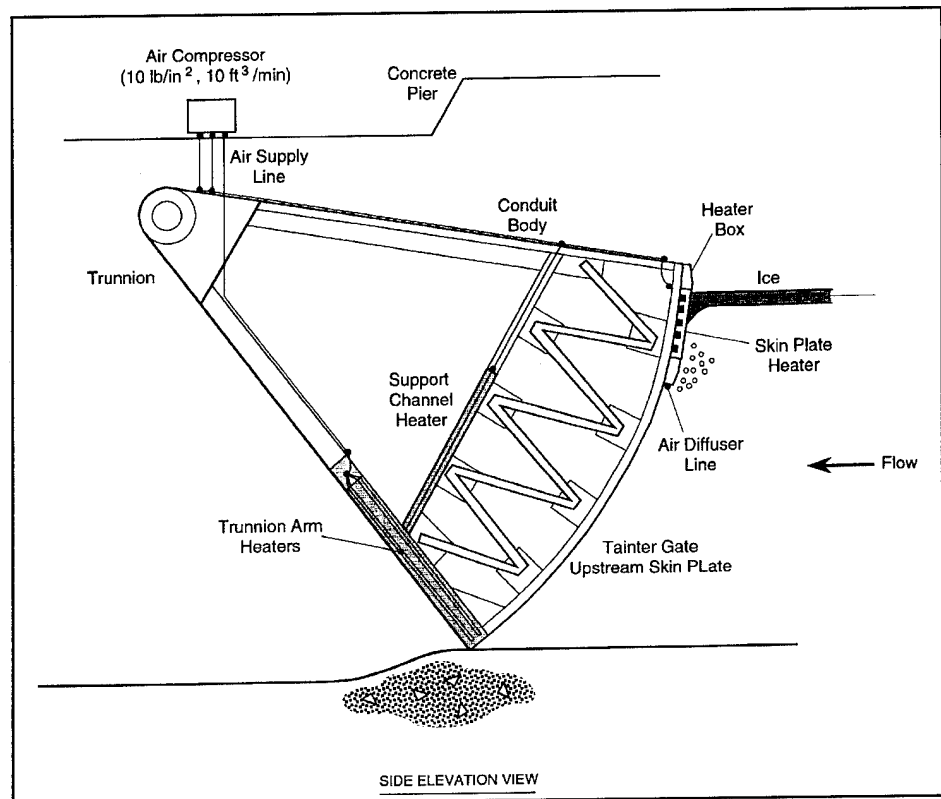

Figure 2. Tainter gate showing various heaters

of each has a pipe plug with a 1/8-in.-diameter hole drilled in it for an orifice. Compressed air is supplied by a 3/4-hp, 10-psi, 10-cfm compressor. Air is delivered down the left-side riser pipe, which contains a check valve to prevent water from filling the delivery pipe and freezing in the winter. The diffuser pipe can fill with water when the compressor is off. A self-regulating heat cable with a capacity of 20 W/ft has been placed inside the diffuser pipe to prevent the water in the pipe from freezing. Electrical power is supplied to the heat cable down the right-side riser pipe.

About 30 min after the heaters in the heater box have been turned on and the steel box has been heated up, the air compressor is turned on. The air bubbles coming out of the diffuser pipe cause the water to flow upward along the warm heater box; this warm water is delivered to the ice on the gate. The combination of heat from the heater box and circulating water to melt the ice is far more efficient than just the heaters alone. Since the skinplate heaters for one gate use 20 kW, considerable energy savings can be realized by operating the heaters less when used in conjunction with the air bubbler.

Details of the lower trunnion arm heater and the support channel heater are shown in Figure 4. Cartridge heaters are enclosed in watertight cavities by steel plates or angles for mechanical protection. Insulation is placed so that heat is directed toward the surfaces most affected by ice. These heaters are also operated before the gates are moved. The heaters for a trunnion arm have a capacity of 450 W/ft of arm length and use a total of 6,200 W. For a support channel, the heater capacity is 175 W/ft, and it uses a total of 1,200 W.

Finite-element model

A two-dimensional heat conduction finite-element program, TDHC, was used to calculate the time required to melt ice from the skinplate. The program was written by Goering and Zarling (1985). It is a time-dependent program that includes phase change so that a moving melt boundary can be easily identified. A sketch of the model is given in Figure 5. Initially, ice is attached to the heater box, and there is a linear temperature gradient through the thickness of the ice. The program is for

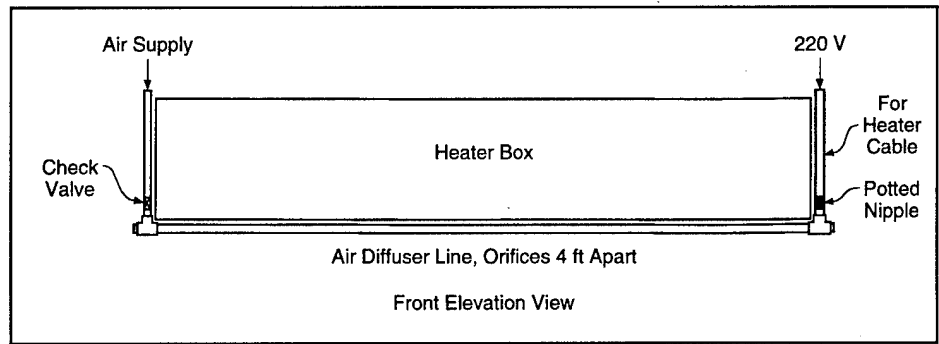

Figure 3. Air diffuser line placed beneath the heater box

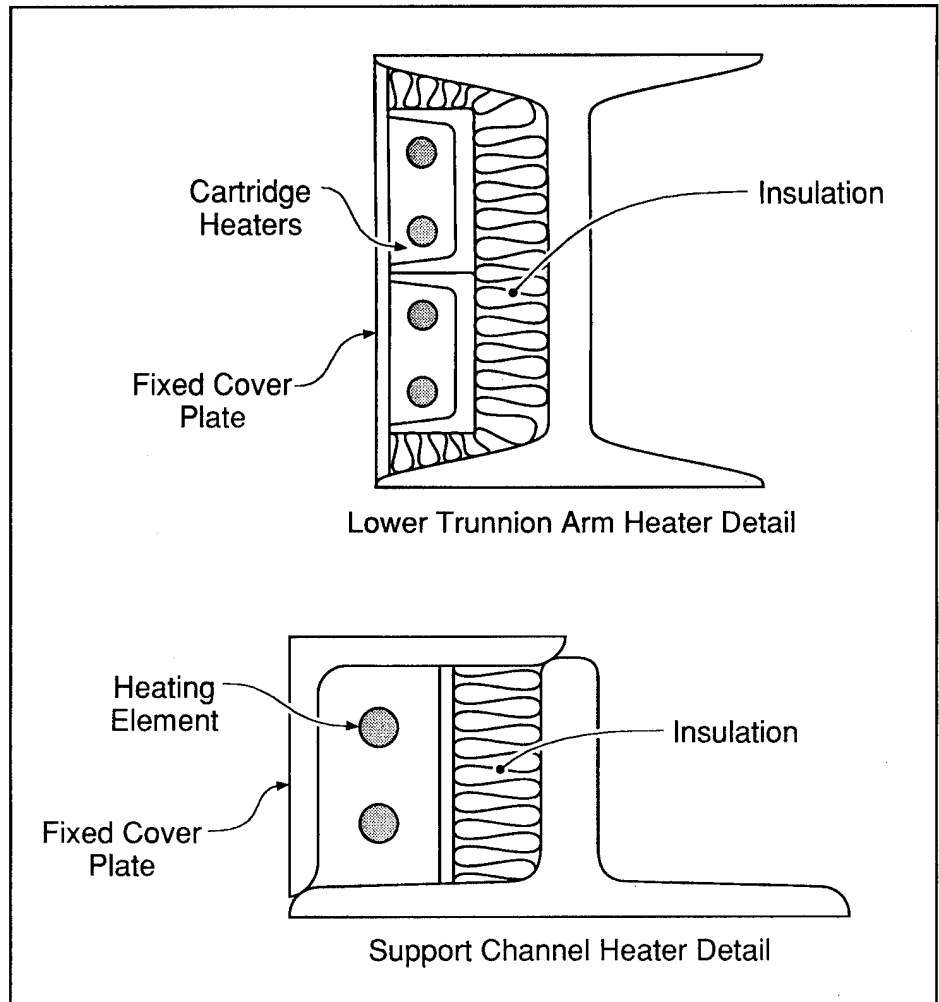

Figure 4. Cross section of lower trunnion arm and support channel heaters

heat conduction only and does not include convection in the water.

For a simulation of the ice-melting operation, a specified heat capacity is applied, and the time is found for melting ice 1 in. away from the gate. Usually, a gate can be moved if the ice is melted 1 in. away. The time to melt the ice from the gate at an air temperature of 17 °F is shown in

Figure 6. The time is a function of the heater capacity in W/ft; the ice thickness, h ; and the air temperature, T_{air} . It is seen that the time increases as the heater capacity decreases and the ice thickness increases.

In addition to simulations with an air-filled cavity, simulations were conducted by considering the cavity to be filled with ethylene glycol and water.

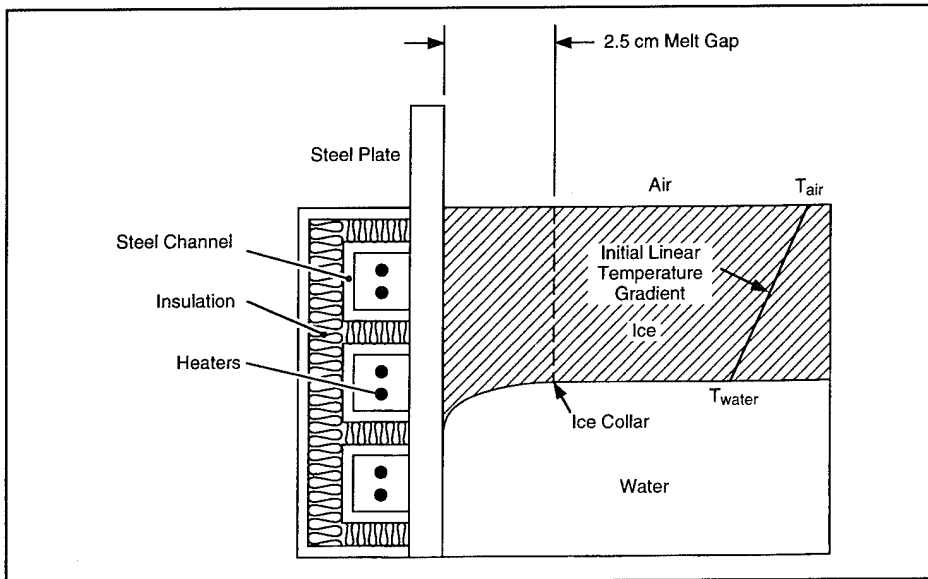

Figure 5. Finite element model setup

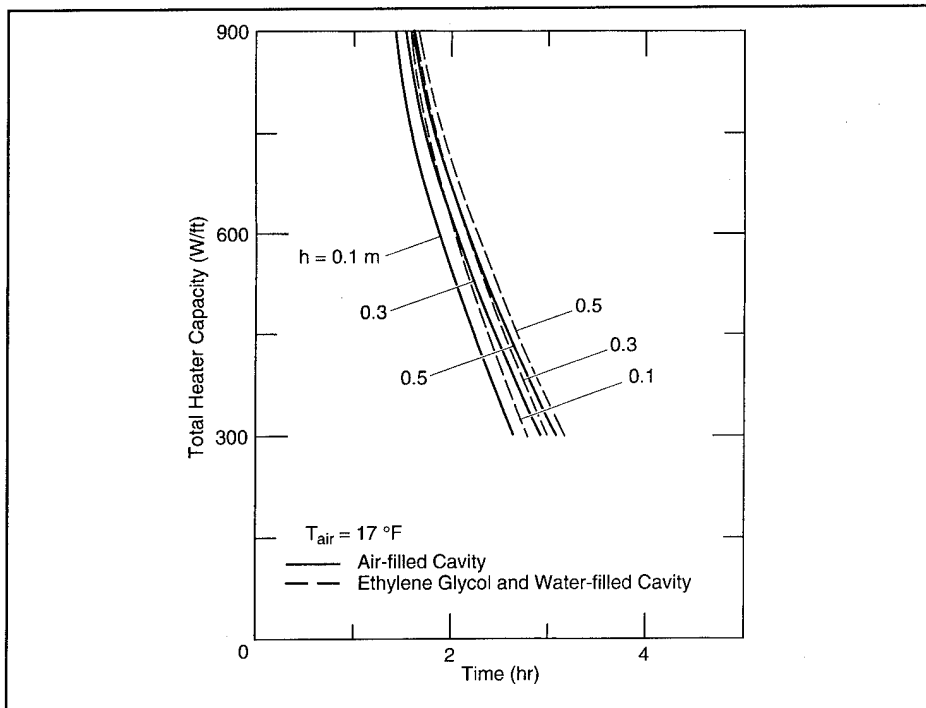

Figure 6. Results of the finite element analysis

For the air-cavity case, the model considered both conduction and radiation heat transfer. For the ethylene glycol- and water-filled cavity, only conduction heat transfer was considered. As shown in Figure 6, the time required to melt 1 in. of ice away from the gate is slightly longer for the ethylene glycol and water than for the air-filled cavity. This is explained by the fact that the volumetric heat capacity for the ethylene glycol and water is about 3,000 times that of air. Considerable sensible heat is required to raise it to the ice-melting temperature in the time frame considered.

Field applications

The use of heaters placed directly on the front of a tainter gate is effective in removing ice that has grown on the gate. Typically, ice needs to be melted about an inch away from the gate before moving the gate. Using air bubblers in conjunction with the heaters can make the ice-melting operation much more efficient and can reduce power requirements. The time required for melting ice can be determined with a finite element program for various conditions.

Reference

Goering, D.J., and Zarling, J.P. (1985). "Geotechnical thermal analysis with a microcomputer," *Civil Engineering in Arctic Offshore*, American Society of Civil Engineers, 604-616.

Donald Haynes is a mechanical engineer in the Ice Engineering Research Branch, CRREL, Hanover, NH. He has a B.S. degree in mechanical engineering from the University of Arizona and an M.S. degree in mechanical engineering from Michigan Technological University. Haynes has over 20 years of experience in applied research on icing problems and is currently Principal Investigator for the REMR research work unit on icing problems. He is a registered Professional Engineer in the State of New Hampshire.



New REMR publications

The following REMR technical reports have been published and may be obtained by writing to Director, U.S. Army Engineer Waterways Experiment Station, ATTN: CEWES-SC-A/Lee Byrne, 3909 Halls Ferry Road, Vicksburg, MS 39180-6199 or by calling (601) 634-2587 (e-mail address byrne@ex1.wes.army.mil).

O'Neil, E.F. (1995). "Repair and Maintenance of Masonry Structures: Case Histories," Technical Report REMR-CS-46, U.S. Army Engineer Waterways Experiment Station, Vicksburg, MS.

Emmons, P.H., and Vaysburd, A.M. (1995). "Performance Criteria for Concrete Repair Materials, Phase I," Technical Report REMR-CS-47, U.S. Army Engineer Waterways Experiment Station, Vicksburg, MS.

Krauss, P.D., Scanlon, J.M., and Hanson, M.A. (1995). "Evaluation of Injection Materials for the Repair of Deep Cracks in Concrete Structures," Technical Report REMR-CS-48, U.S. Army Engineer Waterways Experiment Station, Vicksburg, MS.

McDonald, J.E., and Curtis, N.F. (1995). "Applications of Precast Concrete in Repair and Replacement of Civil Works Structures," Technical Report

REMR-CS-49, U.S. Army Engineer Waterways Experiment Station, Vicksburg, MS.

Meisenheimer, J.K. (1995). "The State of Practice for Determining the Stability of Existing Concrete Gravity Dams Founded on Rock," Technical Report REMR-GT-22, U.S. Army Engineer Waterways Experiment Station, Vicksburg, MS.

Berger, R.C., Stockstill, R.L. and Ott, M.W. (1995) "HIVEL2D User's Manual," Technical Report REMR-HY-13, U.S. Army Engineer Waterways Experiment Station, Vicksburg, MS.

REMR bulletins on-line on the Internet

The REMR Bulletin, Vol. 12, Nos. 1 and 2, are now available on the Internet. The Internet address is <http://www.wes.army.mil/REMR/remr.html>.



Featured in This Issue

Precast concrete panels used to rehabilitate Allegheny River Lock and Dam No. 4	1
Heaters for alleviating icing on tainter gates	8
New REMR publications	11
REMR bulletins on-line on the Internet	11

 PRINTED ON RECYCLED PAPER



The REMR Bulletin is published in accordance with AR 25-30 as one of the information exchange functions of the Corps of Engineers. It is primarily intended to be a forum whereby information on repair, evaluation, maintenance, and rehabilitation work done or managed by Corps field offices can be rapidly and widely disseminated to other Corps offices, other US Government agencies, and the engineering community in general. Contribution of articles, news, reviews, notices, and other pertinent types of information are solicited from all sources and will be considered for publication so long as they are relevant to REMR activities. Special consideration will be given to reports of Corps field experience in repair and maintenance of civil works projects. In considering the application of technology described herein, the reader should note that the purpose of *The REMR Bulletin* is information exchange and not the promulgation of Corps policy; thus guidance on recommended practice in any given area should be sought through appropriate channels or in other documents. The contents of this bulletin are not to be used for advertising, or promotional purposes, nor are they to be published without proper credits. Any copyright material released to and used in *The REMR Bulletin* retains its copyright protection, and cannot be reproduced without permission of copyright holder. Citation of trade names does not constitute an official endorsement or approval of the use of such commercial products. *The REMR Bulletin* will be issued on an irregular basis as dictated by the quantity and importance of information available for dissemination. Communications are welcomed and should be made by writing US Army Engineer Waterways Experiment Station, ATTN: Lee Byrne (CEWES-SC-A), 3909 Halls Ferry Road, Vicksburg, MS 39180-6199, or calling 601-634-2587.

ROBERT W. WHALIN, PhD, PE
Director

CEWES-SC-A
OFFICIAL BUSINESS

DEPARTMENT OF THE ARMY
WATERWAYS EXPERIMENT STATION, CORPS OF ENGINEERS
3909 HALLS FERRY ROAD
VICKSBURG, MISSISSIPPI 39180-6199

BULK RATE
U.S. POSTAGE PAID
Vicksburg, MS
Permit No. 85