

①

Reinforcement Learning Neural Networks for Optical Communications

DTIC
SELECTE
JAN 24 1995
C D

Quarterly Report
October 3, 1995 - January 2, 1996

19960122 028

Prepared for:

Office of Naval Research
Arlington, VA 22217-5660

Contract Number:

N00014-95-C-0072

January 2, 1995 - June 2, 1997

Submitted by:

Michael Salour, Principal Investigator
TACAN Corporation
2330 Faraday Avenue
Carlsbad, CA 92008

UNCLASSIFIED

This document contains proprietary information as defined in FAR Section 3.104-4(j)(1). The data in this document shall not be disclosed outside the Government and shall not be duplicated, used, or disclosed in whole or in part for any purpose other than evaluation of this document.

DTIC QUALITY INSPECTED 1

DISTRIBUTION STATEMENT A
Approved for public release
Distribution Unlimited

A. Project Introduction

The objective of this work is to utilize neural networks to find new methods for optimizing high performance broadband fiber-optic communication links. In typical broadband analog optical communication links, the dominant distortion comes from the laser transmitter. The electrical-to-optical transfer characteristics of both electro-optic external modulators and semiconductor lasers are nonlinear and create both odd- and even-order harmonic distortions of the modulating signal. One cost-effective method to cancel device nonlinearities in direct modulated lasers is by electronic predistortion. For our previous work, based on the simulated annealing learning algorithm utilized for neural network learning, a novel algorithm was developed to obtain the initial parameters of predistortion and laser circuits, and it has been used to linearize the Distributed FeedBack (DFB) semiconductor laser transmitters.

Because predistortion is not self-aligned for optimal performance, this type of laser transmitter would have to be readjusted in the field at various times. This readjustment is necessary in order to maintain optimal performance with variances in device performance due to drifting, aging, or possible changes in nonlinearities when the bias point of the laser changes, as derived from optical power feedback from a laser back facet monitor. The alternative to periodic hand-retuning the transmitter circuits is to use active techniques to monitor the transmitter performance and to compensate for the linearization from the measured performance.

An adaptive control system that is based on artificial neural networks is proposed and is being developed to solve the problem mentioned above and to fulfill the following goals:

- Obtain the initial predistorter parameter settings faster than the current approach; and
- Dynamically adjust the predistorter and the laser parameter settings to compensate for the changes within the system including those induced by the environment.

The major challenge for the design of the proposed adaptive control system is that the selected neural network architecture of the final-designed neural network must be capable of employing both of the following two learning algorithms:

Revision Per
S. 00001
C. TAD
Approved
Distribution

Dist		Special	
A-1			

- A learning algorithm to obtain the initial transmitter parameter settings such as simulated annealing or some deterministic learning algorithms.
- A novel reinforcement learning algorithm used to perform the on-line dynamic control.

B. Overall Progress

B.1 Algorithm Study

Two different stochastic learning neural network architectures, the Boltzmann Machine and the Mean-Field-Theory Machine, have been investigated for the feasibility of applying both the fast stochastic learning and the reinforcement learning (or graded learning) algorithms.

The Boltzmann Machine uses hidden and visible (i.e., inputs and outputs) neurons that are in the form of stochastic, binary-state units. It cleverly links the simulated annealing algorithm with a neural network. The Boltzmann Machine offers some appealing features:

- Through training, the probability distribution of the network is matched to that of the environment;
- The network offers a generalized approach that is applicable to the basic issues of search, representation and learning; and
- The network is guaranteed to find the global minimum of the energy function, provided that the annealing schedule used in the learning process is performed slowly enough.

However, the original proposed annealing schedule is much too slow for all practical applications. In practice, a faster annealing schedule is usually required to produce reasonably good solutions, although they may not be the optimal solutions.

The Mean-Field-Theory Machine is derived from the Boltzmann Machine by analogy. Specifically, the stochastic binary-state neurons of the Boltzmann Machine are replaced by deterministic analog neurons. The end results is a new neural network that offers the following practical advantages:

- Being deterministic, the Mean-Field-Theory Machine is one to two orders of magnitude faster than the corresponding Boltzmann Machine.
- It can be a strong candidate for implementation in VLSI form.

The major limitations of the Mean-Field-Theory Machine is that it is restricted to the simple gradient search; advanced optimization techniques such as the conjugate gradient method are of no value. Furthermore, the use of the Mean-Field-Theory learning is restricted to neural networks with a single hidden layer.

After some investigations, TACAN found that:

- As compared to some fast deterministic learning rules, such as the Levenberg-Marquardt method for the backpropagation learning method, both the Boltzmann Machine and the Mean-Field-Theory Machine require excessive learning time and computation resources;
- The developed stochastic learning neural network may not be easily retrained with reinforcement learning or graded learning algorithm for on-line control process; and
- If the process of searching for the initial parameter settings is too fast, there is too little information to generate a robust, fault-tolerant neural network required for the on-line control process.

On the other hand, the major problem of a supervised learning (deterministic learning) neural network approach is how to generate the learning and testing data sets that must be provided for the network to learn. These data sets should contain the information about the relationships among the parameters of data link performance (e.g., laser, predistorter, etc.). Either empirical data or theoretical data are required to generate these learning and testing data sets.

Practically, since each laser has its own performance characteristics, it is almost impossible to generate a universal equation set that can be used to accurately describe the performance of a laser in terms of the optical transmitter operating parameters (particularly the predistortion parameters used to compensate for the nonlinearities in the laser). Therefore, a specific empirical data set

obtained from each laser is required to train and test a neural network, and this neural network can only be used to control the corresponding laser transmitter.

Currently, the best way of generating an empirical data set for a laser is to use the fast simulated annealing algorithm to search and navigate through the possible states in the multidimensional space generated by the control and the system performance parameters. Previously, the fast simulated annealing algorithm was used to search for the initial parameter settings, and it usually follows one path in the parameter space and ends up at a local minimum of the performance cost function (although it is usually an acceptable operating point).

Therefore, different searching paths are required to generate the empirical data set for neural network training and testing. This multipath approach has two advantages: (a) a global minimum may be obtained as the initial parameter settings, and (b) a robust and generalized neural network controller may be obtained as well.

Due to the reasons specified above, TACAN concludes that a supervised or a deterministic neural network is more appropriate than a stochastic neural network. With the above conclusions, TACAN is developing a novel way to generate the desired deterministic neural network:

- Design a neural network architecture with the inputs and outputs to be directly used to perform the on-line control process.
- Use the fast simulated annealing algorithm to generate the required training and test data files for the neural network.
- Use a fast learning method to train the network, such as the Levenberg-Marquardt method.
- While using the network for on-line control, apply a reinforcement learning or a graded learning method to fine tune the weights of the neural network.

B.2 Neural Network Design

For the purpose of having the ability of being trained by either the backpropagation or the reinforcement learning algorithms, the neural network may have the inputs and outputs shown in

Table 1. The actual size of the change step for the parameters under controlled will depend on the actual hardware design of the laser transmitter and the predistorter circuits.

Table 1: Proposed Inputs and Outputs of the Neural Network

Category	Parameters
Inputs	Laser transmitter temperature control voltage
	Laser transmitter bias control voltage
	Laser transmitter input RF modulation level voltage
	Predistorter 2nd order gain control voltage
	Predistorter 2nd order tilt control voltage
	Predistorter 2nd order phase control voltage
Outputs	Change step of laser transmitter temperature control voltage, 0, or ± 1
	Change step of laser transmitter bias control voltage, 0, or ± 1
	Change step of laser transmitter input RF modulation level voltage, 0, or ± 1
	Change step of predistorter 2nd order gain control voltage, 0, or ± 1
	Change step of predistorter 2nd order tilt control voltage, 0, or ± 1
	Change step of predistorter 2nd order phase control voltage, 0, or ± 1

Figure 1. The Proposed Neural Network Structure

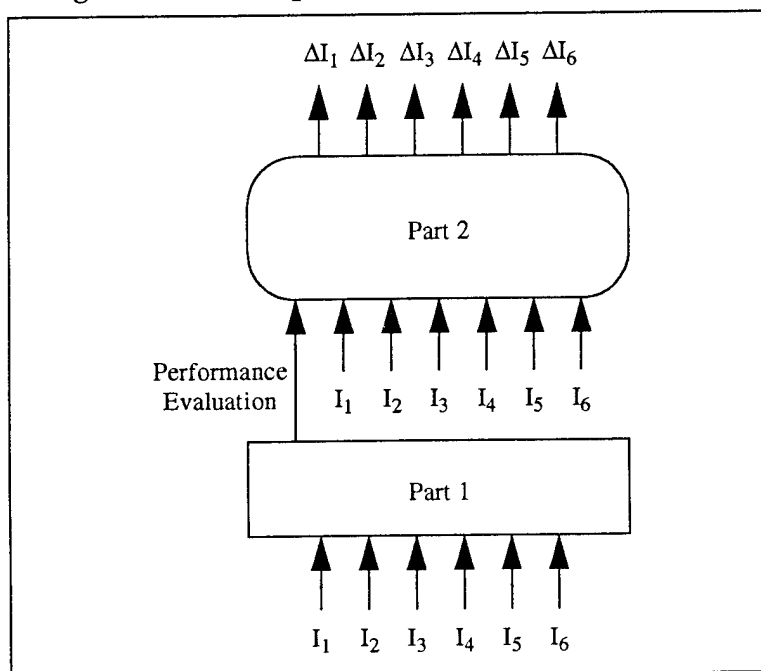

As illustrated in Figure 1, the neural network contains two parts. The first part is trained to learn the relationships between the system performance and the current state of the parameters. The second part, based on the performance and the current state of the parameters, is trained to generate the parameter change steps that will eventually lead the system to perform better. The inputs of the first part are also fed into the second part of the network.

With the training data obtained from a hardware test-bed (as described in Section B.3), the first part of the neural network is trained with the Levenberg-Marquardt method (a backpropagation learning algorithm). The second part of the network is trained with a reinforcement or the graded learning algorithm.

B.3 Hardware Test-Bed Design

To generate the training and testing data, it is necessary to have a hardware test-bed that can be used to explore the multidimensional space generated by the control parameters and the performance evaluation result. The general block diagram of the system, which includes the hardware test-bed and the computer used for simulation and neural network generation is described in Figure 2.

Figure 2. The General Block Diagram of the Hardware Test-Bed

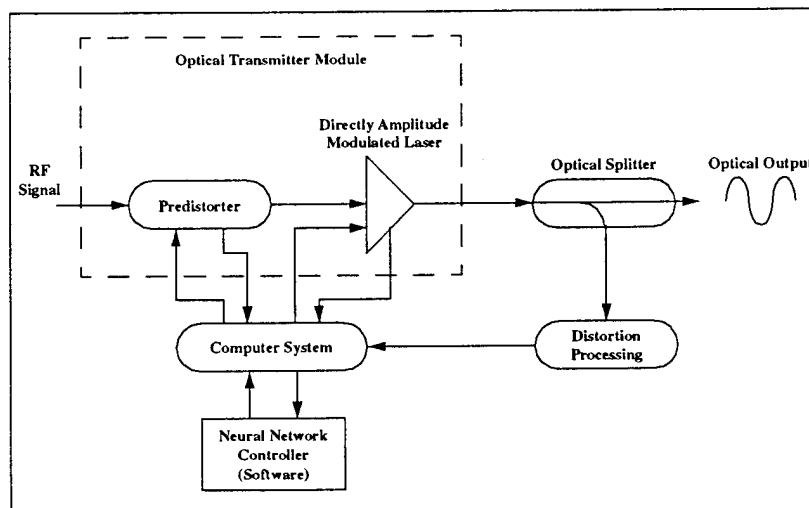

The hardware test-bed includes an optical transmitter module, an optical splitter, one distortion

processing block, the computer system and the neural network software module. The optical transmitter module contains a predistorter circuit and a directly (amplitude) modulated laser. The following sections briefly describe the design of these blocks as shown in Figure 2.

B.3.1 RF Signals Design

The RF signals that are used consist of 42 signal channels sent from an 80-channel CATV headend. The frequencies of these 42 channels are ranged from 55.25 MHz to 337.25 MHz, and they have 6 MHz separation. A pilot tone at 10.7 MHz is generated and added to these 42 RF signals. An RF level adjustment circuit is designed to tune the level of the RF signals to a desired level before they are processed by the predistorter of the optical transmitter module, and Figure 3 briefly illustrates the block diagram of the circuits used to adjust the RF level.

Figure 3. The Block Diagram of the RF Level Adjustment Circuits

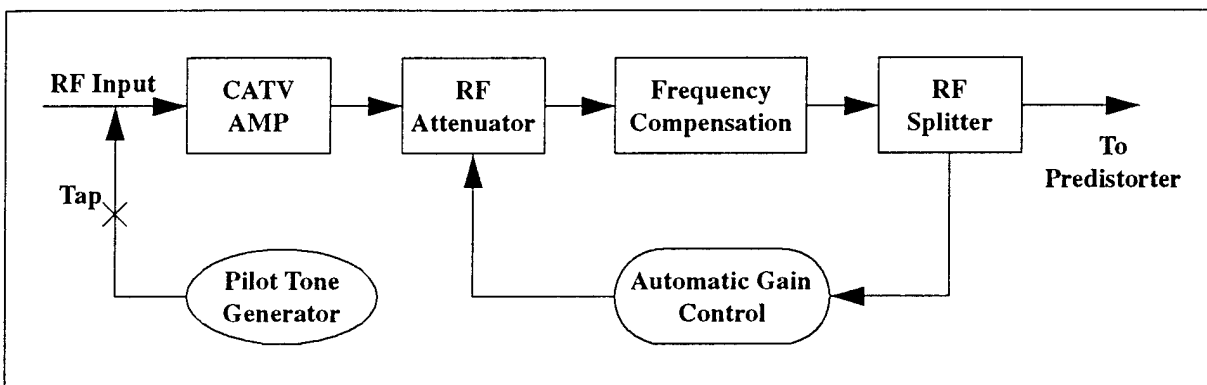

B.3.2 Predistorter Design

As shown in Figure 4, the predistorter circuit is designed to generate second harmonic signals from the input RF signals. By combining the generated second harmonic signals and the input RF signals, this circuit outputs distorted RF signals to the amplitude modulated laser. With the predistorted RF signals, the nonlinear characteristics produced by the amplitude modulated laser can be decreased or even compensated totally. The predistorter circuit contains two 180° power splitter/combiner modules. The first power splitter/combiner module splits the RF signals into two half-power signals with 180° phase difference. These two half-power signals are then fed into two discrete amplifiers which, at certain RF level, clip the half-power RF signals and then

generate higher order harmonics. The second power splitter/combiner module then combines these two distorted half-power RF signals to recover the input RF signals and the second harmonic signals.

Figure 4. Block Diagram of the Predistorter Circuit

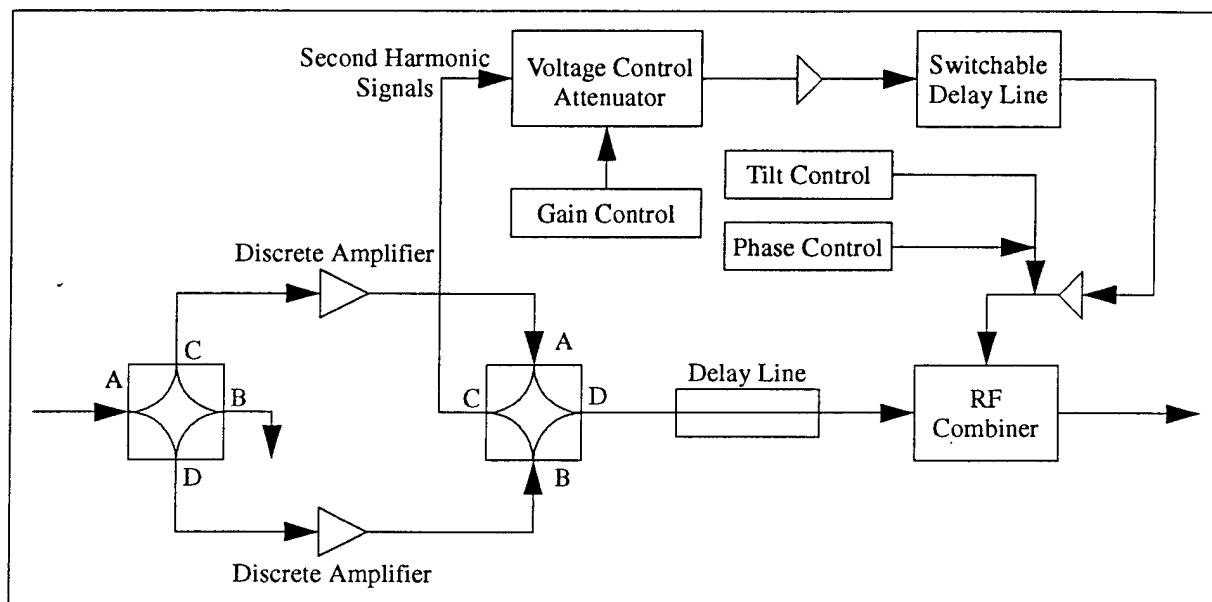

B.3.3 Distortion Processing Block Design

The distortion processing block contains two major devices, as shown in Figure 5. The FiberNode Receiver is a commercial product of TACAN Corporation. It receives the 1310 nm laser beam and converts the embedded information data back to RF signals. The distortion signals extractor is designed to extract specific signals from the received 42 channel RF signals. It splits the power of the received RF signals into three different parts, processing them with different filters and signal mixers. Finally, three different RF signals with frequency equal to 10.7 MHz are generated and sent to the computer.

Figure 5. The Block Diagram of the Distortion Processing Block

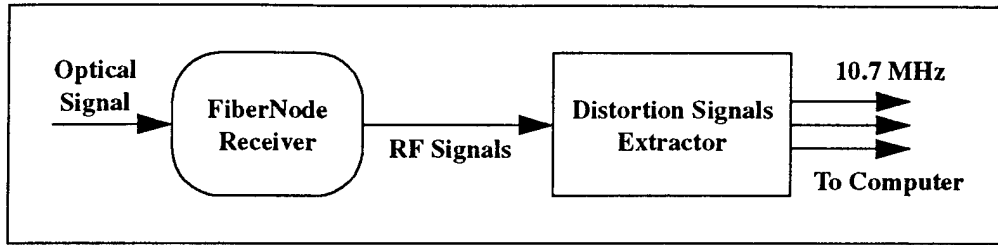

Figure 6. The Block Diagram of the Distortion Signals Extractor

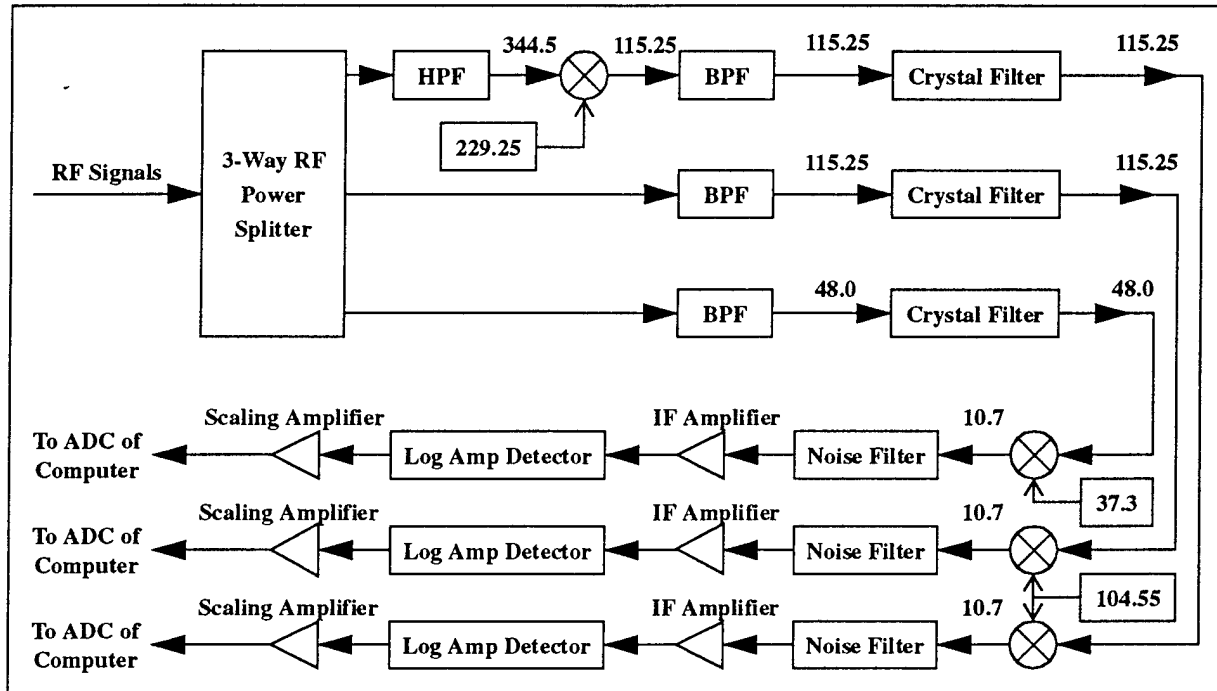

Figure 6 exhibits the design of the distortion signals extractor. With the 3-way RF power splitter, the received RF signals are split into three different parts. The first part is high-pass filtered to 344.5 MHz, then mixed with a local oscillator at 229.25 MHz to get 115.25 MHz. The second part is band-pass filtered to 115.25 MHz, and the third part is band-pass filtered to 48.0 MHz. Then the filtered signals are mixed with local oscillators of 104.55 MHz (for the first and the second part) and 37.3 MHz (for the third part) to generate three different RF signals with frequency equal to 10.7 MHz. Finally, these three RF signals are noise filtered and scaled according to the A/D convertors designed in the computer.

C. Current Problems

None.

D. Ongoing Work

The following items are currently in progress for this project:

- Verify the correct A/D and D/A signal conversions between the hardware test-bed and the computer.
- Generate codes to implement the fast simulated annealing algorithm, and the necessary codes used to generate the training and testing data files.
- Write program codes for the neural network implementation and the I/O interfaces between the hardware and the neural network designed.

E. Fiscal Status

- | | |
|---|-----------|
| 1. Amount currently provided on contract: | \$611,872 |
| 2. Expenditures and Commitments to date: | \$ 61,060 |
| 3. Funds required to complete work: | \$550,812 |