**DRAFT FINAL
CLOSURE PLAN FOR THE BASIN F INTERIM
RESPONSE ACTION STRUCTURES**
TERC Contract No. DACW45-94-D-0001,
Delivery Order No. 5

19960123 087

Prepared for:
U.S. Army Corps of Engineers
Omaha District
and
Program Manager for Rocky Mountain Arsenal
Building 111, Rocky Mountain Arsenal

Prepared by the RUST TERC 1 Team
RUST Environment & Infrastructure
RUST Remedial Services
Harding Lawson Associates
OA Systems

DISTRIBUTION STATEMENT A
Approved for public release;
Distribution Unlimited

September 1994

RUST E & I Project No. 55051.000

REPORT DOCUMENTATION PAGE

Form Approved
OMB No. 0704-0188

Public reporting burden for this collection of information is estimated to average 1 hour per response, including the time for reviewing instructions, searching existing data sources, gathering and maintaining the data needed, and completing and reviewing the collection of information. Send comments regarding this burden estimate or any other aspect of this collection of information, including suggestions for reducing this burden, to Washington Headquarters Services, Directorate for Information Operations and Reports, 1215 Jefferson Davis Highway, Suite 1204, Arlington, VA 22202-4302, and to the Office of Management and Budget, Paperwork Reduction Project (0704-0188), Washington, DC 20503.

1. AGENCY USE ONLY (Leave blank)		2. REPORT DATE 09/00/94	3. REPORT TYPE AND DATES COVERED	
4. TITLE AND SUBTITLE CLOSURE PLAN FOR THE BASIN F INTERIM RESPONSE ACTION STRUCTURES, DRAFT FINAL			5. FUNDING NUMBERS	
6. AUTHOR(S)			DACW45 94 D 0001	
7. PERFORMING ORGANIZATION NAME(S) AND ADDRESS(ES) RUST ENVIRONMENT AND INFRASTRUCTURE, INC. DENVER, CO			8. PERFORMING ORGANIZATION REPORT NUMBER 94255R01	
9. SPONSORING / MONITORING AGENCY NAME(S) AND ADDRESS(ES) ARMY CORPS OF ENGINEERS. OMAHA DISTRICT OMAHA, NEBRASKA			10. SPONSORING / MONITORING AGENCY REPORT NUMBER	
11. SUPPLEMENTARY NOTES				
12a. DISTRIBUTION / AVAILABILITY STATEMENT APPROVED FOR PUBLIC RELEASE; DISTRIBUTION IS UNLIMITED			12b. DISTRIBUTION CODE	
13. ABSTRACT (Maximum 200 words) THIS DOCUMENT PRESENTS THE ARMY'S FINAL CLOSURE PLAN FOR FOUR BASIN F INTERIM RESPONSE ACTION STRUCTURES AT RMA. THESE STRUCTURES INCLUDE POND A, POND B, THE TANK FARM, AND THE SUBMERGED QUENCH INCINERATOR (SQI). POND A, POND B, AND THE TANK FARM WERE CONSTRUCTED TO TEMPORARILY STORE LIQUID FROM BASIN F UNTIL A TREATMENT AND DISPOSAL METHOD COULD BE SELECTED. THE DISPOSAL METHOD WAS LATER DETERMINED TO BE INCINERATION IN THE SQI. SECTION 2 OF THIS PLAN PRESENTS A GENERAL DESCRIPTION OF THE RMA FACILITY AND THE BASIN F IRA STRUCTURES, SECTION 3 PRESENTS A DETAILED DISCUSSION OF THE CLOSURE PROCESS AND ASSOCIATED WASTE MANAGEMENT, SECTION 4 DESCRIBES THE ANTICIPATED SCHEDULE FOR CLOSURE OF THE BASIN F IRA STRUCTURES, SECTION 5 PROVIDES A CONTINGENCY CLOSURE PLAN, AND SECTION 6 PROVIDES A LIST OF REFERENCES USED IN THIS DOCUMENT.				
14. SUBJECT TERMS DISPOSAL, POND A, POND B, TANK FARM, SQI			15. NUMBER OF PAGES	
			16. PRICE CODE	
17. SECURITY CLASSIFICATION OF REPORT UNCLASSIFIED	18. SECURITY CLASSIFICATION OF THIS PAGE	19. SECURITY CLASSIFICATION OF ABSTRACT	20. LIMITATION OF ABSTRACT	

TABLE OF CONTENTS

<u>Section</u>	<u>Page</u>
1.0 INTRODUCTION	1-1
2.0 FACILITY DESCRIPTION	2-1
2.1 <u>HAZARDOUS WASTE MANAGEMENT UNITS ASSOCIATED WITH BASIN F LIQUID</u>	2-1
2.2 <u>PHYSICAL SETTING</u>	2-3
2.3 <u>HYDROGEOLOGIC INFORMATION</u>	2-3
2.3.1 <u>Geology and Hydrology</u>	2-3
2.3.2 <u>Groundwater Monitoring System</u>	2-5
2.4 <u>AIR MONITORING</u>	2-6
2.5 <u>DESCRIPTION OF STRUCTURES</u>	2-6
2.5.1 <u>Ponds A and B</u>	2-6
2.5.2 <u>Tank Farm</u>	2-9
2.5.3 <u>Submerged Quench Incinerator</u>	2-10
2.6 <u>WASTES MANAGED IN BASIN F IRA STRUCTURES</u>	2-15
3.0 CLOSURE PROCEDURES	3-1
3.1 <u>WASTE INVENTORY AT CLOSURE</u>	3-1
3.1.1 <u>Bulk Waste</u>	3-1
3.2 <u>CLOSURE PROCESS</u>	3-2
3.2.1 <u>Decontamination Phase</u>	3-2
3.2.2 <u>Removal Phase</u>	3-8
3.2.3 <u>Restoration Phase</u>	3-16
3.2.4 <u>Certification Phase</u>	3-18
3.3 <u>PROCEDURES FOR HANDLING CLOSURE WASTE</u>	3-19
3.3.1 <u>Structure-Specific Wastes</u>	3-19
3.3.2 <u>Offsite Disposal</u>	3-21
3.3.3 <u>Decontamination Verification Procedure</u>	3-22
3.4 <u>SOIL VERIFICATION SAMPLING PROGRAM</u>	3-23
3.4.1 <u>Sampling Methodology</u>	3-23
3.4.2 <u>Soil Verification Sampling Standards</u>	3-24
3.4.3 <u>Sample Collection</u>	3-25
3.4.4 <u>Field Sampling QA/QC</u>	3-26
3.4.5 <u>Analytical Procedures</u>	3-26
3.4.6 <u>Chain-of-Custody Procedures</u>	3-26
3.5 <u>RUNON AND RUNOFF CONTROL</u>	3-27
3.6 <u>GROUNDWATER MONITORING</u>	3-27
3.7 <u>SITE SECURITY</u>	3-27
3.8 <u>SAFETY AND HEALTH PLAN</u>	3-28
3.9 <u>DECONTAMINATION</u>	3-28
3.10 <u>SPILL PREVENTION AND RESPONSE</u>	3-28

TABLE OF CONTENTS
(Continued)

3.11	<u>COST ESTIMATE AND FINANCIAL ASSURANCE</u>	3-29
3.12	<u>SURVEY PLAT</u>	3-29
3.13	<u>TRANSPORTATION</u>	3-29
4.0	<u>CLOSURE SCHEDULE</u>	4-1
4.1	<u>EXPECTED YEAR OF CLOSURE</u>	4-1
4.2	<u>MILESTONE CHART</u>	4-1
4.2.1	<u>Decontamination Phase</u>	4-1
4.2.2	<u>Removal Phase</u>	4-2
4.2.3	<u>Restoration Phase</u>	4-3
4.2.4	<u>Certification Phase</u>	4-4
4.3	<u>TOTAL TIME TO CLOSE</u>	4-4
4.4	<u>REQUEST FOR EXTENSION TO DEADLINES</u>	4-4
4.5	<u>AMENDMENT OF CLOSURE PLAN</u>	4-4
5.0	<u>CONTINGENCY CLOSURE PLAN</u>	5-1
6.0	<u>REFERENCES</u>	6-1

LIST OF TABLES

<u>Table No.</u>	<u>Title</u>
2.3-1	1994 Quarterly Basin F Interim Response Action Area Groundwater Quality Monitoring Network
2.6-1	Basin F Liquid Waste Characteristics
3.1-1	Estimated Volume of Tanks Residue
3.2-1	SQI Equipment Requiring Internal Decontamination Procedures
3.2-2	SQI Equipment Requiring External-Rinse Decontamination Procedures
3.2-3	SQI Equipment Requiring No Decontamination Procedures
3.3-1	Solid Waste Generation Summary for Pond A and B Closure
3.3-2	Waste Generation Summary for Tank Farm Closure
3.3-3	Waste Generation Summary for SQI Closure
3.3-4	Basin F Structures Waste Stream Disposal/Treatment Matrix
3.4-1	Soils Verification Standards

LIST OF FIGURES

<u>Figure No.</u>	<u>Title</u>
2.0-1	Site Location Map
2.1-1	General Location Map for Basin F Liquid Containment Structures
2.2-1	Basin F Interim Response Action Liquid Containment Structures on Topographic Map
2.3-1	Quarterly Basin F Groundwater Quality Monitoring Well Locations and Air Quality Monitoring Stations
2.5-1	Basin F Ponds A and B
2.5-2	Representative North-South Pond Cross-Section
2.5-3	Pond Leachate Collection and Removal System Details
2.5-4	Tank Storage Unit Design
2.5-5	Basin F Tank Farm Plan
2.5-6	Typical Leak Detection System for Basin F Tank Farm Storage Unit
2.5-7	Cathodic Protection Test Hub and Fuse Location
2.5-8	Submerged Quench Incinerator and Emission Control Design
2.5-9	Submerged Quench Incinerator Building Plan
3.2-1	Standardized Closure Process
3.2-2	Pond Cover/Liner Removal Diagram
3.2-3	Ponds A and B System Layout
3.4-1	Basin F Ponds A and B Soil Verification Sampling Grid
3.4-2	Basin F Tank Farm Plan Soil Verification Sampling Grid
4.2-1	Closure Schedule

LIST OF ACRONYMS AND ABBREVIATIONS

Army	U.S. Department of the Army
CCR	Colorado Code of Regulations
CDH	Colorado Department of Health
CERCLA	Comprehensive Environmental Response, Compensation, and Liability Act
CHWMA	Colorado Hazardous Waste Management Act
CMP	Comprehensive Monitoring Program
DAA	Detailed Analysis of Alternatives
Ebasco	Ebasco Services, Inc.
EPA	U.S. Environmental Protection Agency
ESE	Environmental Science and Engineering, Inc.
HDPE	High-Density Polyethylene
HLA	Harding Lawson Associates
ICP	Inductively Coupled Plasma
IEA/RC	Integrated Endangerment Assessment/Risk Characterization
IRA	Interim Response Action
LDR	Land Disposal Restriction
mg/l	Milligrams Per Liter
MKE	Morrison-Knudsen Engineering
msl	Mean Sea Level
OCP	Organochlorine Pesticide
Ponds	Pond A and Pond B
PPE	Personal Protective Equipment
RCRA	Resource Conservation and Recovery Act
RMA	Rocky Mountain Arsenal
SQI	Submerged Quench Incinerator
Structures	Pond A, Pond B, the Tank Farm, and the SQI
VOC	Volatile Organic Compound

1.0 INTRODUCTION

This document presents the U.S. Department of the Army's (Army's) Final Closure Plan for four Basin F Interim Response Action (IRA) structures (Structures) at Rocky Mountain Arsenal (RMA) in Commerce City, Colorado. These Structures include Pond A, Pond B, the Tank Farm, and the Submerged Quench Incinerator (SQI). Pond A, Pond B, and the Tank Farm were constructed to temporarily store liquid from Basin F until a treatment and disposal method could be selected. The disposal method was later determined to be incineration in the SQI. The Army has prepared this Closure Plan in accordance with the Colorado Hazardous Waste Regulations found at 6 Colorado Code of Regulations (CCR) 1007-3, Part 265, as required in paragraph 27 of Compliance Order on Consent No. 93-08-05-01 that was issued by the Colorado Department of Health (CDH) to the Army on August 5, 1993.

The Army intends to clean close the Structures in accordance with 6 CCR 1007-3, Part 265 Subpart G. As described in this Closure Plan, closure activities will begin for any specific structure once the Basin F liquid contained in that Structure has been treated in the SQI and the closure contractor has mobilized to the site. Closure activities for the Structures will include removing residue, removing and demolishing the liner and leak detection systems, decontaminating and dismantling the Structures, testing the soil beneath the Structures for potential contamination, removing any contaminated soils, and regrading the excavations.

This Closure Plan meets the requirements for closure plan content specified in 6 CCR 1007-3, Section 265.112(b): Section 2 of this plan presents a general description of the RMA facility and the Basin F IRA Structures; Section 3 presents a detailed discussion of the closure process and associated waste management; Section 4 describes the anticipated schedule for closure of the Basin F IRA Structures; Section 5 provides a contingency closure plan; and Section 6 provides a list of references used in this document.

2.0 FACILITY DESCRIPTION

RMA occupies more than 17,000 acres in Adams County, Colorado, northeast of the metropolitan Denver area (Figure 2.0-1). The RMA property was primarily used for agricultural purposes prior to 1942, but was purchased by the U.S. Government in 1942 and used during World War II to manufacture and assemble chemical warfare materials and incendiary munitions. A significant amount of chemical warfare materials destruction took place during the 1950s, 1960s, and 1970s. The last military operations ended in the early 1980s, and in November 1988, RMA was reduced to inactive military status with the only remaining mission being environmental restoration. In addition to military activities, major portions of the RMA facilities were leased to private industries, including Shell Oil Company between 1947 and 1982, for the manufacture of various insecticides and herbicides.

Past disposal practices at RMA have included routine discharge of industrial and munitions waste effluent to evaporation basins. In 1956, Basin F was constructed in the northern portion of RMA. Basin F had a surface area of 92.7 acres and a capacity of approximately 243 million gallons. The basin was created by constructing of a dike around a natural depression and was lined with a 3/8-inch catalytically blown asphalt membrane. An earthen blanket, approximately 1 foot thick, was placed on top of the membrane to protect it. From August 1957 until its use was discontinued in December 1981, Basin F was the only evaporative unit in service at RMA.

2.1 HAZARDOUS WASTE MANAGEMENT UNITS ASSOCIATED WITH BASIN F LIQUID

In 1986, the Army, Shell Oil Company, and the U.S. Environmental Protection Agency (EPA) Region VIII decided that an accelerated remediation should be conducted to address the liquid and soil in and under Basin F. This remediation was undertaken pursuant to the Comprehensive Environmental Response, Compensation, and Liability Act of 1980 (CERCLA). The first interim response action for Basin F liquid, sludge, and soil remediation included transferring Basin F liquid to three lined storage tanks at the Tank Farm and two double-lined impoundments

identified as Pond A and Pond B (Ponds) (Figure 2.1-1). This Basin F IRA was performed during 1988 and early 1989.

During May 1988, the Army began transferring Basin F liquid to the three lined tanks at the Tank Farm for interim storage. Additional capacity in the Ponds was necessary because seasonal precipitation had increased the volume of the liquid beyond the initial estimate. Approximately 3 million gallons of liquid were pumped from Basin F to the three lined tanks from May through August 1988.

Basin F liquid was transferred to the three lined tanks while construction of Pond B was being completed. Six-thousand-gallon vacuum trucks pumped liquid out of Basin F, transported it to the Basin F Tank Farm, and gravity-drained the liquid to a small transfer basin. The liquid was pumped from the transfer basin into the three lined tanks. Basin F liquid was also pumped directly to Pond B after it was completed during July and August 1988.

During the transfer of liquid to Pond B, a solidified stratum of hardened material was uncovered in Basin F. An additional 3 million gallons of liquid were entrained within and below this layer. The total capacity of the three tanks in the Tank Farm and Pond B was insufficient to contain all the Basin F liquid; therefore, remaining Basin F liquid was pumped to Pond A. During August and September 1988, liquid from Pond B was also transferred to Pond A. During December 1988, an additional 1 million gallons of liquid were transferred from Pond A to the three lined tanks. Approximately 4 million gallons of liquid were stored at the Tank Farm and approximately 6.5 million gallons of liquid were stored in Pond A. Currently, Pond B contains no liquid.

The second interim response action for Basin F liquid addressed treatment and disposal of the contents of the three lined storage tanks and Pond A. This IRA was initiated in September 1988, and in May 1990 the Army elected to treat the Basin F liquid by incineration. The SQI was constructed in 1992 and is located approximately 800 feet southeast of the Tank Farm.

2.2 PHYSICAL SETTING

RMA is a limited access facility accessible only to authorized personnel. In addition, a 7-foot chain-link fence topped with barbed wire surrounds Ponds A and B, the Tank Farm, and the SQI operations area. Access to the area is limited to approved Army and contractor personnel. The Structures are located in the northeast quarter of Section 26 as presented in Figure 2.1-1. Off-road traffic is limited to approved Army and contractor personnel. The land surrounding the Structures is within the boundaries of RMA and is used primarily as a wildlife refuge.

The topographic setting surrounding the Structures is illustrated in Figure 2.2-1. The ground surface elevation ranges from approximately 5184 feet above mean sea level (msl) to 5209 feet above msl. The ground immediately surrounding some of the Structures has been contoured with berms to prevent runoff. Precipitation accumulating within the boundaries of the berms is discussed in Section 2.5.4. Surface water outside of the berms flows north or northeast. No floodplains have been identified around the Structures.

2.3 HYDROGEOLOGIC INFORMATION

This section describes the general geology and groundwater hydrogeology characterizing the area surrounding the Structures, as well as the Basin F groundwater monitoring network. The regional geology and hydrology have been discussed in detail in numerous reports including May (1982); Environmental Science and Engineering, Inc. (ESE) (1987, 1988a, 1988b, and 1988c); Morrison-Knudsen Engineers, Inc. (MKE) (1988); and Ebasco Services, Inc. (Ebasco) (1989) and are not discussed in detail in this Closure Plan.

2.3.1 Geology and Hydrology

Immediately underlying the Structures are Quaternary deposits, which overlie the Denver Formation. A claystone layer forms the base of the Denver Formation and provides a confining layer between the Denver Formation and the underlying Arapahoe Formation. This discussion will focus on the Quaternary deposits and the weathered Denver Formation because they are in the closest vertical proximity to the Structures.

The Quaternary surficial deposits, commonly called the Quaternary alluvium, consist of unconsolidated alluvial and colluvial fill and eolian sand. The lower alluvial and colluvial material is composed of glacial outwash and terrace deposits containing cobbles and boulders in a matrix of clay, silt, sand, and gravel. Paleochannels eroded into the Denver Formation are also filled with coarse-grained sand and gravel. Eolian and finer-grained alluvial deposits commonly form the uppermost alluvial deposits throughout much of RMA.

The alluvial stratigraphy in the vicinity of the Structures conforms to the lithology expected. The lithologic logs for alluvial monitoring wells and Denver Formation monitoring wells in the area where the Structures are located indicate that the Quaternary alluvium is approximately 45 feet deep. Approximately 20 feet of clay and silt overlie 25 feet of coarsening downward sand with gravel. No significant alluvial paleochannels have been identified immediately beneath Pond A, Pond B or the Tank Farm. The lithologic log for alluvial monitoring well 26124 indicates a potential alluvial paleochannel may exist approximately 500 feet northeast of the SQI.

Underlying the alluvial material is the Cretaceous-Tertiary Denver Formation, which is composed primarily of claystone with interbedded siltstone and sandstone lenses. The Denver Formation dips slightly to the southeast. Much of the Denver Formation has eroded and approximately 250 feet remains in the northern portion of Section 26 (ESE 1988a). Approximately 10 to 30 feet of the upper Denver Formation is weathered.

Groundwater at RMA occurs under both unconfined (at atmospheric pressure) and confined (greater than atmospheric pressure) conditions. The Quaternary alluvium and weathered upper parts of the Denver Formation form a generally continuous groundwater system, and the groundwater is typically under unconfined conditions. Confining strata inhibit groundwater interaction between the upper unconfined strata and deeper permeable zones in the Denver Formation, causing confining conditions to exist.

In the unconfined flow system, groundwater flow occurs in saturated alluvium in silt, sand, and gravel, glacial outwash, eolian sand, and in the weathered Denver Formation. Groundwater

flow occurs primarily in the saturated alluvium, which generally has a higher hydraulic conductivity and transmissivity than the unconfined Denver Formation. Groundwater flow is most rapid through alluvium filled paleochannels incised into the Denver Formation. In the immediate vicinity of the Structures, saturated alluvium ranges from extremely thin (0 to 5 feet thick) with seasonally localized unsaturated conditions to unsaturated alluvial conditions where the unconfined groundwater flow is through the weathered Denver Formation. The depth to groundwater generally ranges from 40 to 50 feet below ground surface.

The confined flow system consists of flow through generally unweathered Denver Formation sandstones, siltstones, and lignites under confined conditions. This discussion does not address groundwater flow in the confined flow system.

Regional groundwater flow at RMA is to the northwest; however, in the vicinity of the Structures groundwater flow is to the north and north-northeast. The average hydraulic gradient at RMA is approximately 0.006, but is 0.002 to 0.02 in the vicinity of the Structures. Aquifer tests performed on the alluvial wells in the vicinity of the Structures yielded a transmissivity of 7060 to 14,440 square feet per day and a hydraulic conductivity of 930 to 1655 feet per day (1.076×10^2 to 1.915×10^{-2} feet per second) (Vispi 1978).

2.3.2 Groundwater Monitoring System

Several contaminant source areas in Section 26 could have historically affected or may continue to affect groundwater quality in the vicinity of the Structures. Contaminant source areas have been described by ESE (1987, 1988a, 1988b, and 1988c) and HLA (1992). The studies have identified groundwater contamination in the vicinity of the former Basin F area.

Water quality monitoring is conducted on a quarterly basis in the Basin F IRA area. The 1994 quarterly Basin F IRA area monitoring network, which consists of the 14 wells listed in Table 2.3-1 and shown in Figure 2.3-1, is a subset of a much larger RMA-wide monitoring network (HLA 1993). The wells in the Basin F IRA area monitoring network monitor the

unconfined flow system to assess background contamination levels and the affects of the Structures on the groundwater quality.

2.4 AIR MONITORING

Air monitoring is an element of the Comprehensive Monitoring Program (CMP) at RMA under which baseline data that were established under the Remedial Investigation Program continue to be collected. The air monitoring data collected are used to evaluate ambient air quality levels at RMA in support of remedial activities. The CMP uses three modes of monitoring: 1) routine baseline monitoring every 6 days; 2) "high event" monitoring during specified meteorological conditions to measure peak concentrations of volatile organic compounds (VOCs), organochlorine pesticides (OCPs), arsenic, and metals; and 3) remedial monitoring as direct support for on-site remedial and construction activities.

The air monitoring element of this Closure Plan consists of a network of fixed and portable monitoring stations used in the CMP to collect air samples. There are two fixed air monitoring stations located in the vicinity of the Structures, as illustrated in Figure 2.3-1. Two mobile air monitoring stations will be placed around each of the Structures during closure activities. The two fixed and two mobile stations will be sampled based on established routines and schedules. This air monitoring program has stations properly located to support closure activities, and the stations will function on the routine schedule for the duration of each Structure.

2.5 DESCRIPTION OF STRUCTURES

The following sections provide a physical description of Ponds A and B, the Tank Farm, and SQI, as well as details concerning design and component equipment.

2.5.1 Ponds A and B

Ponds A and B were constructed in 1988 and are located in the northern portion of Section 26, south of 9th Street and west of the Tank Farm (Figure 2.0-1). This section describes the design of Ponds A and B and includes a description of the liner, leachate collection, and precipitation control systems.

2.5.1.1 Ponds A and B Design and Ancillary Equipment

Pond A is 424 feet by 382 feet (approximately 3.77 acres), as illustrated in Figure 2.5-1. Pond B is 375 feet by 375 feet (approximately 3.23 acres), also illustrated in Figure 2.5-1. Pond A is 10.4 feet deep at the center of the north side and 13.5 feet deep at the center of the south side. Pond B is 6.8 feet deep at the center of the north side, and 10 feet deep at the center of the south side. The pond bottoms slope toward the south at a 1 percent grade. The bottom of the ponds is also sloped toward the north-south centerline at a 1 percent grade. A representative cross section of the ponds along the north-south centerline is shown in Figure 2.5-2.

In addition to the ponds described above, the following ancillary equipment exists in association with Pond A. A floating pipeline connects Pond A to a pumphouse (Pumphouse No. 1) in a closed system. Pumphouse No. 1 consists of a steel frame building with corrugated metal siding on a concrete slab. One of two pumps transfers the Basin F liquids to Pumphouse No. 2, located south of the Tank Farm, in an aboveground pipeline. A purge water tank and pump are located within the pumphouse to flush the pipeline after each transfer. A concrete sump is located within the pumphouse to provide secondary containment. The pumphouse is also equipped with several heaters to allow pumping operations in winter months. The location of Pumphouse No. 1 and the aboveground pipeline are shown in Figure 2.5-1. Pond B does not have the ancillary equipment discussed above.

2.5.1.2 Liner Systems and Leachate Collection System

The Ponds are lined with a combination of high-density polyethylene (HDPE) and geonet as shown in Figure 2.5-2. The bottom layer of the 60-mil HDPE (secondary liner) was placed on a 12-inch compacted clay foundation. A layer of 200-mil geonet was placed over the HDPE for leachate collection, in strips 7.5 feet wide and in 200-foot-long panels held together with nylon ties placed every 5 feet. A second layer of 60-mil HDPE (primary liner) was placed over the geonet. The primary liner was constructed of 6-foot-wide HDPE rolls that were welded in the field by a radiant-heated apparatus using the double seam technique. The combined liner is

anchored at the top of the impoundment berm by a 12-inch-deep trench filled with dike and embankment materials.

A sump is located at the base of the liner at the south-central side of the Ponds, as shown in Figure 2.5-3. The sump is constructed to collect any liquid (leachate) that accumulates in the geonet layer. The sump is a 12-inch-deep by 15-inch-diameter HDPE prefabricated sump filled with drain gravel. A 6-inch-diameter HDPE lateral pipe is fuse welded to the sump and is used to transfer (gravity drain) the liquid to a 6-inch-diameter riser pipe. The lateral pipe is approximately 45 feet long and slopes down and away from the sump at a 2 percent grade. The end of the lateral pipe is attached with a "tee" to a 15-foot-long vertical riser pipe. A leachate removal pump sits inside the "tee." The top of the riser pipe is 3 feet above the top of the berm and 5 feet outside the edge of the berm. The liquid is pumped to a tank for volume measurement and is returned to the pond.

Pond A is covered by a white 45-mil-thick Hypalon synthetic membrane cover anchored outside the perimeter of the pond. Styrofoam floaters or "ribs" have been installed in sleeves welded to the cover. The north-south ribs are spaced 30 feet apart, with one double rib placed in the center of the pond. One double rib was also installed in the middle of the pond in the east-west direction. Until July, 1994, a layer of approximately 4 inches of water was maintained atop the cover to protect it from being uplifted by wind. Plans for late summer for the pond A cover include the design and interpretation of an interim ballast system to act in lieu of the layer of water. Four pressure relief vents were installed in the cover along the perimeter of the pond to release any vapor pressure that may develop above the liquid.

The cover and liner systems completely enclose the liquid in Pond A. Two openings currently exist in the cover in addition to the vents. One is located about 40 feet from the center of the perimeter dike near the middle of the south side of the pond, adjacent to the north-south double rib. It consists of a hatch measuring 17.5 inches by 23.5 inches. The second opening is a fill port along the side slope of the pond in the northwest corner, through which a conduit has been inserted. This conduit is used to allow liquid to be added to the pond.

2.5.2 Tank Farm

The Tank Farm is located east of Pond B on 9th Avenue (Figure 2.1-1). A description of the tank area design, ancillary equipment, leak detection systems, and secondary containment system design is included.

2.5.2.1 Tank Area Design and Ancillary Equipment

The Tank Farm is composed of three tanks (101, 102, and 103) and was initially intended to hold all of the Basin F liquid (Figure 2.0-1). The three tanks, which are similar in size and design, were built in 1987. Each tank is constructed with carbon steel sidewalls, has a double bottom constructed of carbon steel, and is supported by concrete ringwalls. Each tank is 78.5 feet in diameter and approximately 40 feet in height, as shown in Figure 2.5-4. The tanks are lined with a 100-mil high-density polyethylene (HDPE) liner and is covered with an Alumadome® roof, which is comprised of aluminum sheets overlying an aluminum I-beam framework. They contained a total volume of approximately 4 million gallons of Basin F liquid, each tank containing approximately 1.3 million gallons. The liquid in Tank 102 has been incinerated.

Nondestructive T-scan tests have been run on Tanks 101, 102, and 103 periodically since their construction. Additional tests have been run on Tank 102. The results of these tests, which are available from the Program Manager for Rocky Mountain Arsenal (PMRMA), indicate that the three tanks are currently structurally sound.

The Tank Farm is configured as illustrated in Figure 2.5-5. An aboveground pipeline connects each tank to Pumphouse No. 2 in a closed system. Pumphouse No. 2 is a steel frame building with corrugated metal siding, and contains similar equipment (pumps, purge tank, etc.) as Pumphouse No. 1. An aboveground double-wall pipeline connects Pumphouse No. 2 and continues to the SQI in a closed system. Each tank has a 10-inch-diameter vent located on the cover, one 8-inch-diameter gage port, and one 24- by-24-inch access hatch at the base. Stairs welded to the walls of the tanks provide access to a deck on the top of the steel walls of each tank. An access hatch is located approximately 4 feet from the deck on each tank roof.

2.5.2.2 Secondary Containment and Leak Detection System Design

Each tank is equipped with a leak detection system (Figure 2.5-6). A 200-mil HDPE drainage net leak detection system is located between the tank liner and the steel walls of each tank. Eight annular drain valve assemblies are located around the base of each tank and can be opened to detect and remove any liquid located between the tank liner and tank wall. The 100-mil HDPE liners in Tanks 101 and 103 are assumed to be intact because no leakage has been detected in the leak detection system. The liner in Tank 102 appears to have been damaged, as assessed by the presence of Basin F liquid in the leak detection system. Each tank is also equipped with cathodic protection (Figure 2.5-7).

Secondary containment is provided by an earthen berm covered by a 100-mil HDPE liner that is capable of containing the contents of one tank plus the accumulated volume of a 25-year 24-hour rainfall event. The liner is covered with 1 foot of clay and covers the entire bermed area with the exception of the tank foundations.

2.5.3 Submerged Quench Incinerator

The SQI is located on D Street approximately 1200 feet south of 9th Avenue (Figure 2.0-1). A description of the design and configuration of the SQI is provided in this section, as well as a description of the combustion unit design, emission control system, and residuals handling system is included.

Systems Descriptions and Design

The primary processes involved in the destruction of Basin F liquid waste hazardous compounds are high temperature thermal oxidation to destroy organic contaminants followed by high energy scrubbing for particulate emission control and caustic scrubbing for acid mist removal from the exhaust gases. The principal equipment associated with the thermal destruction system, illustrated in Figure 2.5-8, includes:

- A submerged quench incinerator, quench tank, and quench separator
- A high energy venturi scrubber for particulate emission control

- A packed tower scrubber for acid vapor control
- An instrumentation system to automatically monitor and control the system

Support systems for the incinerator include liquid waste storage and feed, residue (brine) storage and loading, caustic storage and feed, and utilities.

Specific support and auxiliary equipment components, illustrated in Figure 2.5-9, include:

- Feed day tanks and a wastewater feed system
- A steam boiler for incinerator feed atomization and other plant process heating requirements
- A gas service line to supply gas to the facility
- A potable water line to supply service and fire water to the facility
- A caustic storage, dilution, and transfer system
- A brine storage and loading system
- An industrial drain system to collect industrial wastes from the facilities to be treated in the incinerator
- Two compressed air systems to provide instrument and plant air to the facilities
- An emergency power system capable of ensuring an orderly and safe shut down of the incinerator during emergency power shutdown conditions
- A fire protection system to ensure adequate fire-fighting capability during emergency conditions
- Electrical switch gear and transformers
- Building heating and ventilating equipment
- An internal communications system
- A facility roadway system to access the operation

In addition, the treatment facility includes the following service buildings:

- SQI building, approximately 9700 square feet and 76 feet high (maximum), to house the incinerator equipment and tanks
- A lunchroom trailer for employee convenience
- A laboratory trailer used for instrument repair
- A process control building to house all the process control and monitoring equipment
- A change room for personnel uniform changing and showering
- A switch gear house for power distribution
- A diesel generator and fuel oil storage tank
- A fire water pump building

A plan view of the SQI site showing the location of the major structures is illustrated in Figure 2.5-9.

The Basin F liquid is fed to the SQI at a rate within the final operating conditions of approximately 176 pounds per minute. Supplementary fuel (natural gas) and combustion air for the fuel and the waste are fed to the incinerator. Additional air for atomizing the feedstream is also fed into the system. Basin F liquid, atomizing air, and part of the combustion air are injected into the flame zone just below the vortex burner. The incinerator operates under positive pressure and the combustion is via forced draft. The natural gas-fired, vortex-type burner maintains the combustion chamber at the desired temperature. In the event that the measured oxygen level in the stack gases falls below a specified level, the natural gas supply and the burner are automatically shut off.

The combustion chamber is a vertical refractory-lined, carbon steel, cylindrical shell. The refractory lining consists of sections of high-alumina brick varying in aluminum content to optimize resistance to the effects of varying temperature, chloride level, and salt composition.

The aqueous waste is injected through a series of five externally atomized nozzles located downstream of the burner flame. The design of the nozzles allows atomization using either air or steam. The injection assembly that supports each nozzle consist of two concentric pipes: the inner pipe is used for the waste feed and the outer pipe is used for the atomizing media.

The downcomer, located inside the quench tank, is fabricated of Hastelloy C-276 to withstand the heat and corrosion of the flue gases. The inside of the downcomer is continuously washed with water introduced at the top of the downcomer by a water box assembly. This wash lowers the temperature of the downcomer and also prevents build up of particulates on the inside surface.

The quench tank is fabricated of lined carbon steel. The lining is comprised of an inner layer of puroflex and an outer layer of acid brick. The crossover ductwork is constructed of Hastelloy C-276. The recirculation rate around the quench tank is maintained with the quench water salvage/reuse pump. The brine bleed rate from the system is manually set by a density meter to maintain a constant salt concentration in the bleed stream. The water level in the quench tank is maintained using a liquid- level controller. The quench tank is designed with a V-bottom to facilitate solids removal. Brine is recirculated through two nozzles located at opposite ends of the "V."

The separator tower is designed to remove water droplets carried over in the gas stream from the quench tank. The water is then salvage/reused back into the quench tank. The remaining gases pass on to the venturi scrubber. The separator tower is made of fiberglass reinforced plastic-lined carbon steel. The separator tower has two observation ports, an emergency overflow port, spare flanged connections, lifting lugs, and other connections and accessories.

Emission Control Systems

The combustion gases exiting the separator pass through a venturi scrubber for particulate removal and then through a packed tower scrubber for acid gas removal and neutralization.

Differential pressure and salvage/reuse flow rate across the venturi throat are monitored and adjusted to maintain proper particulate removal. The liquid flow into the throat of the venturi scrubber is provided by redundant salvage/reuse pumps.

The packed tower scrubber, illustrated in Figure 2.5-8, is 34 feet high and is 8 feet in diameter. The packed tower scrubber is a vertical, cylindrical tower that uses a 10 percent caustic solution as the neutralizing agent. The scrubber system consists of pumps, an absorber section, a mist eliminator to remove water droplets from the flue gases, and an exhaust stack. Water is added to the scrubber to maintain the level from liquid lost as a result of evaporation and liquid blowdown to the quench/separator system.

The SQI is equipped with a continuous emission monitoring (CEM) system. The CEM system monitors the gaseous emissions leaving the scrubber and transmits signals from the CEM analyzers back to the process monitoring and control system (PMCS) in the main control room. The CEM is an extraction type system designed to measure the following seven constituents of the stack emissions:

- Oxygen (O₂)
- Carbon dioxide (CO₂)
- Carbon monoxide (CO)
- Hydrochloric acid (HCl)
- Nitrogen oxides (NO_x)
- Sulfur oxides (SO_x)
- Total hydrocarbons (THC)

The O₂ analyzer's signal is used to control combustion air flow into the SQI chamber. The CO analyzer's signal is averaged by the PMCS to update a rolling hourly average.

Residuals Handling System

The SQI generates a brine stream (approximately 20 weight percent salt), which also contains residual heavy metals including recoverable levels of copper. This brine is pumped to two holding tanks with a capacity of 41,000 gallons each. This total capacity of 82,000 gallons is sufficient to store the brine produced during approximately 1.5 days of incinerator operation. The storage tanks operate in parallel on a batch basis. One tank is used to fill tank trucks for removal while the other tank is receiving the brine from the incinerator process. The tank trucks then transfer the brine to railcars, which transport it to an offsite metal reclaiming facility.

2.6 WASTES MANAGED IN BASIN F IRA STRUCTURES

Ponds A and B and the Tank Farm contain liquid drained from the former Basin F as part of the first IRA which is currently being incinerated in the SQI. Pond A also holds liquid collected from the Basin F waste-pile leachate collection system and secondary containment, excess precipitation collected on the Pond A cover, and precipitation collected from the Tank Farm secondary containment area. Approximately 6.5 million gallons of Basin F liquid was stored in Pond A, and the tanks contained approximately 4 million gallons. Approximately 300,000 gallons of rinse water from the Hydrazine Facility closure and 100,000 gallons of rinse water from the decontamination of Tank 102 have been added to Pond A. Pond B is currently empty and was decontaminated in 1988.

Based on previous sampling and analysis activities conducted by the Army, Basin F liquid is an aqueous liquid containing a complicated mixture of hydrocarbons, chlorinated hydrocarbons, salts, metals, and other process intermediates, byproducts, and wastes, as summarized in Table 2.6-1. The total organic carbon content (as C) reported for Basin F liquid ranges from 18,000 to 23,000 milligrams per liter (mg/l). Historical analytical data indicate that several pesticides are also present in Basin F liquid, but these levels are relatively low when compared to the overall total organic content. Although the major metallic inorganic species are sodium and potassium, concentrations of heavy metals, particularly copper, are also present.

Besides Basin F liquid, Pond A and Tanks 101 and 103 contain a thin layer of residue that precipitated/settled from the liquid contents. A reflective acoustic technique was used to

estimate the volume of residue in Pond A at 2400 cubic yards. The Army obtained measurements of the depth to the residue in each tank and this measurement, combined with the height and diameter of the tanks, was used to estimate the volume of residue present. Tanks 101 and 103 are estimated to have 360 and 200 cubic yards of residue, respectively. Residue in Tank 102 was removed in June of 1994 as a part of a decontamination field demonstration. Initial results indicate a removed quantity of 149 cubic yards of residue vs. 180 cubic yards originally estimated.

The Army had samples of the residue collected from Tank 102 in September 1991 and submitted for a physical and chemical analysis. Although the samples had been drained to remove as much Basin F liquid as possible, a small amount of liquid was still present. The residue was dark brown to black and very hard. The results of the chemical analysis indicated that the residue consisted of inorganic salts and water with an approximate composition of water (28.4 percent), sodium sulfate (65.5 percent), other inorganic salts (6.9 percent), and total organic carbon (0.2 percent). The residue sample was used to obtain an estimate of the bulk density for the residue of 0.865 grams per cubic centimeter.

TABLE 2.3-1
1994 QUARTERLY BASIN F INTERIM RESPONSE ACTION AREA
GROUNDWATER QUALITY MONITORING NETWORK

Section	Total Number of Wells	Well Designations - Unconfined Flow System Wells
23	3	23049, 23220, 23239
26	11	26015, 26020, 26041, 26095, 26160, 26162, 26163, 26164, 26168, 26169, 26170
	<hr style="width: 10%; margin: auto;"/> 14	

**TABLE 2.6-1
BASIN F LIQUID WASTE CHARACTERISTICS**

Analyte	Units	Range of Data	Representative Value ^a
Total Solids	mg/l	249,000 to 557,000 ^b	474,000
TDS	mg/l	128,000 to 419,000 ^{b,c}	318,000
TSS	mg/l	32 to 1600 ^{b,d}	111
TVS	mg/l	103,000 to 301,000 ^{b,c}	208,000
Percent Ash	%	14.3 to 21.8 ^{c,e}	19.6
Flashpoint	°F	> 230 ^{c,e}	> 230
Elemental Analysis			
Carbon	%	5.21 to 7.32 ^{c,e}	5.31
Hydrogen	%	7.47 to 8.05 ^{c,e}	7.76
Nitrogen	%	7.42 to 9.55 ^{c,e}	7.88
Sulfur	%	1.41 to 2.81 ^{c,e}	1.45
Chlorine	%	11.88 to 12.74 ^{c,e}	12.55
Oxygen	%	45.11 to 59.54 ^{c,e}	48.21
Volatile Organics^f			
Chloromethane	µg/l	4900 to 9500 ^c	8000
Bromomethane	µg/l	42 to 76 ^c	58
Chloroethane	µg/l	ND to 13 ^c	ND
Toluene	µg/l	ND to 47 ^c	16
Semivolatile Organics^f			
Dimethylmethylphosphate	µg/l	240,000 to 360,000 ^c	250,000
Dimethyl disulfide	µg/l	80,000 to 120,000 ^d	100,000
4-Nitrophenol	µg/l	ND to 33,000 ^{c,d}	8600
p-Chlorophenylmethylsulfoxide	µg/l	1000 to 26,000 ^d	10,000
p-Chlorophenylmethylsulfone	µg/l	120,000 to 170,000 ^c	140,000
Pesticides^f			
Aldrin	µg/l	11 to 35 ^c	12
Heptachlor epoxide	µg/l	3 to 10 ^c	3.6
Dieldrin	µg/l	34 to 95 ^c	56
Endrin	µg/l	1 to 9 ^c	5.2
Endrin ketone	µg/l	1 to 3 ^c	2.5
Herbicides	µg/l	ND ^c	ND
Dioxins/Furans	ng/l	ND ^c	ND
Nitrogen^g			
Ammonia/ammonium	mg/kg	22,100 to 70,300 ^{b,c,d}	61,100
TKN	mg/kg	141,000 to 298,000 ^c	146,000
Nitrate/nitrite	mg/kg	1830 to 2580 ^{b,c}	2300
Urea	%	5.4 to 34 ^{c,d}	23

TABLE 2.6-1
BASIN F LIQUID WASTE CHARACTERISTICS

Analyte	Units	Range of Data	Representative Value ^a
Miscellaneous Parameters			
pH	--	5.8 to 7.2 ^{b,c,d}	6.4
Specific gravity	--	1.115 to 1.246 ^{b,c,d}	1.22
Heating Value	Btu/lb	1141 to 2230 ^{c,e}	1750
Conductivity	μmho/cm	110,000 to 174,000 ^{b,d}	136,000
Hardness	mg/l	2100 to 2900 ^d	2450
Alkalinity	mg/l	1500 to 7900 ^d	1700
Viscosity (2° C)	cp	4.6 to 5.0 ^d	4.8
Viscosity (15° C)	cp	2.9 to 3.1 ^d	3.0
Viscosity (25° C)	cp	2.1 to 2.3 ^d	2.2
TOC	mg/l	55,000 to 195,000 ^b	117,000
COD	mg/l	158,000 to 230,000 ^d	205,000
TOX (total halide)	mg/l	340 to 570 ^d	430
Metals			
Aluminum	mg/l	3.1 to 5.5 ^b	4.5
Antimony	mg/l	0.6 to 1.1 ^d	0.8
Arsenic	mg/l	1 to 8 ^{b,d,e}	3.7
Barium	mg/l	ND to 0.4 ^{d,e}	0.4
Boron	mg/l	10.5 to 21 ^{b,d}	15.2
Cadmium	mg/l	0.01 to 0.2 ^{d,e}	0.05
Calcium	mg/l	6.8 to 270 ^{b,d}	164
Chromium	mg/l	0.1 to 1.9 ^{b,d,e}	1.0
Cobalt	mg/l	0.82 to 0.93 ^d	0.9
Copper	mg/l	210 to 5860 ^{b,d}	3179
Iron	mg/l	5 to 75 ^{b,d}	32.8
Lead	mg/l	ND to 0.07 ^{d,e}	ND
Magnesium	mg/l	5.6 to 250 ^{b,d}	150
Manganese	mg/l	6.8 to 7.2 ^d	7.0
Mercury	mg/l	0.03 to 0.34 ^{d,e}	0.21
Molybdenum	mg/l	2.4 to 2.6 ^d	2.5
Nickel	mg/l	20 to 34 ^{b,d}	30.8
Phosphorous	mg/l	389 to 16,200 ^{b,d}	9000
Potassium	mg/l	30 to 2900 ^{b,d}	825
Selenium	mg/l	1.7 ^e	1.7
Silver	mg/l	0.44 ^e	0.44
Sodium	mg/l	2300 to 65,000 ^{b,d}	37,600
Vanadium	mg/l	2.5 to 3 ^d	2.7
Zinc	mg/l	0.95 to 23 ^{b,d}	16.6
Anions			
Chloride	mg/l	85,000 to 159,000 ^{b,d}	138,000
Fluoride	mg/l	18.1 to 170 ^{b,d}	22.1
Sulfate	mg/l	17,200 to 47,000 ^{b,d}	24,400

**TABLE 2.6-1
BASIN F LIQUID WASTE CHARACTERISTICS**

Analyte	Units	Range of Data	Representative Value ^a
Ash Analysis^b			
Bromide	mg/kg	3810 to 4270 ^c	4020
Fluoride	mg/kg	ND ^c	ND
Iodide	mg/kg	ND ^c	ND
Chloride	mg/kg	385,000 to 453,000 ^c	422,000
Phosphate	mg/kg	28,100 to 65,600 ^c	39,900
Sulfate	mg/kg	5360 to 36,000 ^c	21,300
Sodium	mg/kg	258,000 to 382,000 ^c	308,000
Potassium	mg/kg	3520 to 4670 ^c	4090
Calcium	mg/kg	712 to 1140 ^c	915
Magnesium	mg/kg	1140 to 1660 ^c	1340
Cyanide	mg/kg	0.8 to 5.4 ^c	4.0
Antimony	mg/kg	ND ^c	ND
Arsenic	mg/kg	ND ^c	ND
Beryllium	mg/kg	ND ^c	ND
Cadmium	mg/kg	ND ^c	ND
Chromium	mg/kg	6.4 to 8.8 ^c	7.3
Copper	mg/kg	13,600 to 19,800 ^c	15,300
Lead	mg/kg	ND ^c	ND
Mercury	mg/kg	ND ^c	ND
Nickel	mg/kg	90.4 to 138 ^c	110
Selenium	mg/kg	ND ^c	ND
Silver	mg/kg	ND ^c	ND
Thallium	mg/kg	ND ^c	ND
Zinc	mg/kg	91.7 to 130 ^c	105

%	Percent
Btu/lb	British thermal units per pound
cp	Chemically pure
mg/kg	Milligrams per kilogram
mg/l	Milligrams per liter
ND	Analyte not detected above quantitation limit
ng/l	Nanograms per liter
°F	Degrees Fahrenheit
µg/l	Micrograms per liter
µmho/cm	Micromhos per centimeter

- a. Representative values based primarily on analytical data collected by WESTON in October 1990 and May 1991. Additional data compiled by Woodward-Clyde Consultants and T-Thermal are used to fill in data gaps. The median value for a specific range of data was chosen as the representative value.
- b. Roy F. Weston, Inc., September 1991, Basin F Liquid Characterization Findings Report Addendum.
- c. Roy F. Weston, Inc., February 1991, Basin F Liquid Characterization Findings Report.
- d. Woodward-Clyde Consultants, December 1989, Final Treatment Assessment Report (Volume I).

TABLE 2.6-1
BASIN F LIQUID WASTE CHARACTERISTICS

- e. T-Thermal, Inc., July 1989, Treatability Test of Basin F Liquid using SQI.
- f. Only organic compounds detected above their quantitation limit are presented.
- g. Basin F liquid heated to a temperature of 105°C (to remove volatile fraction) prior to nitrogen analyses.
- h. Basin F liquid heated to a temperature of 550°C. Remaining ash analyzed for the following parameters.

Source: Weston, 1992

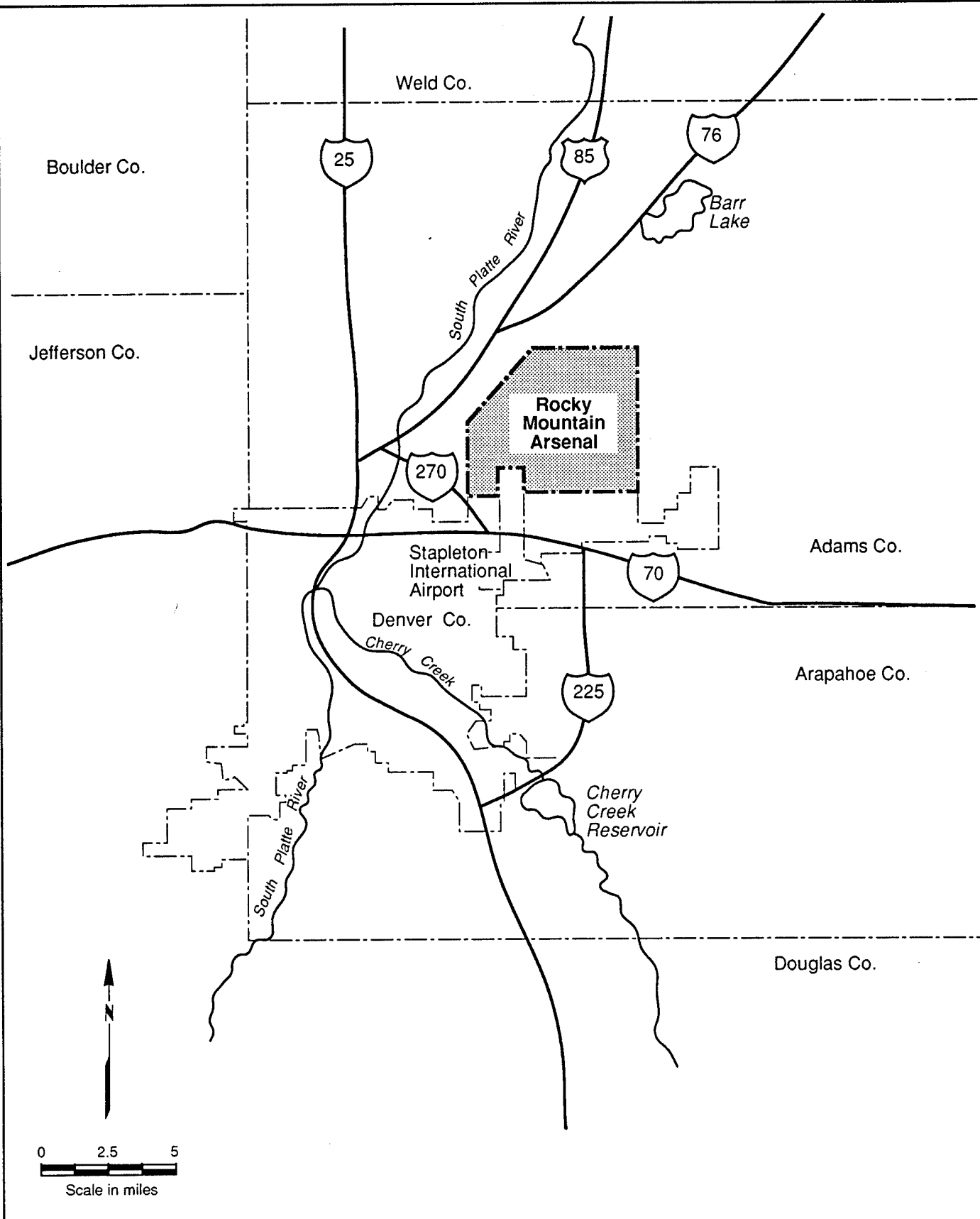

Prepared for:
 Program Manager for
 Rocky Mountain Arsenal
 Commerce City, Colorado

Prepared by:
 RUST TERC 1 Team

Figure 2.0-1
Site Location Map

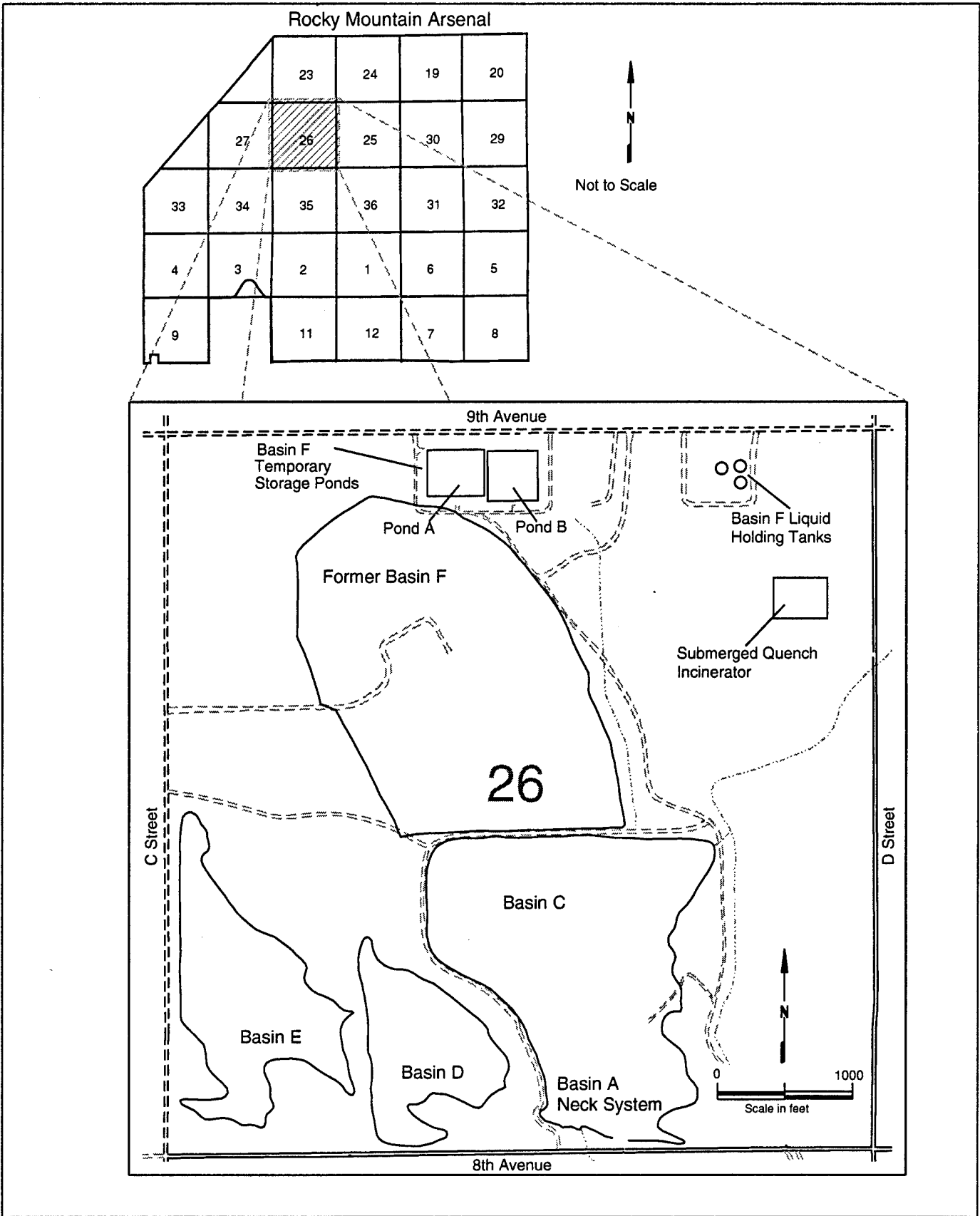

RMA/SEC28VIC 8/4/94 LDZ

Prepared for:
 Program Manager for
 Rocky Mountain Arsenal
 Commerce City, Colorado

Prepared by:
 RUST TERC 1Team

Figure 2.1-1
General Location Map for Basin F
Liquid Containment Structures

①

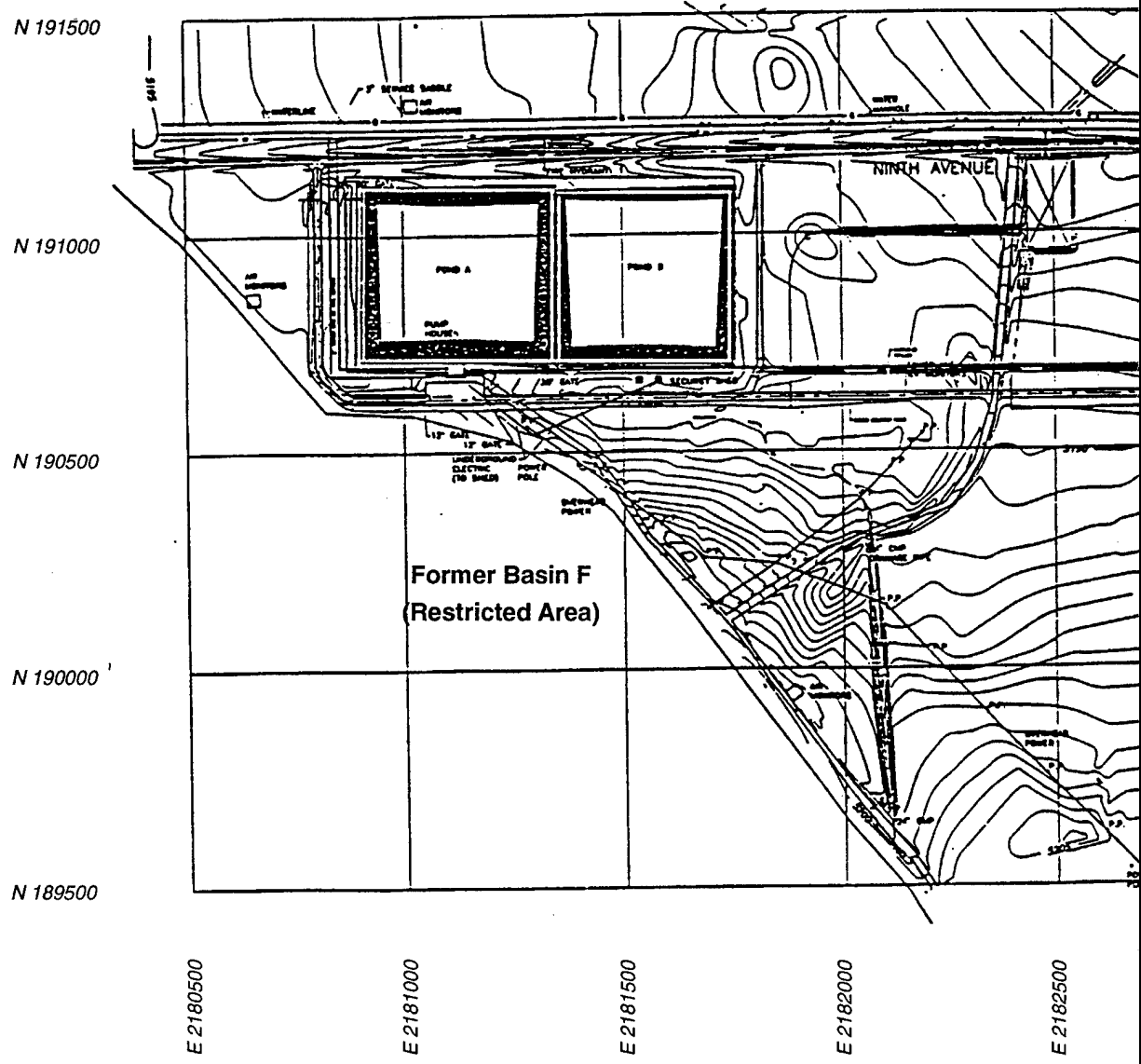

Notes:

For clarity, topographic contour lines are shown below the SQI, Ponds, and Tank Farm.

Part of existing information on this drawing prepared from Woodward-Clyde Consultants drawing 00-02-001. 8/15/90.

Source: Weston 1992.

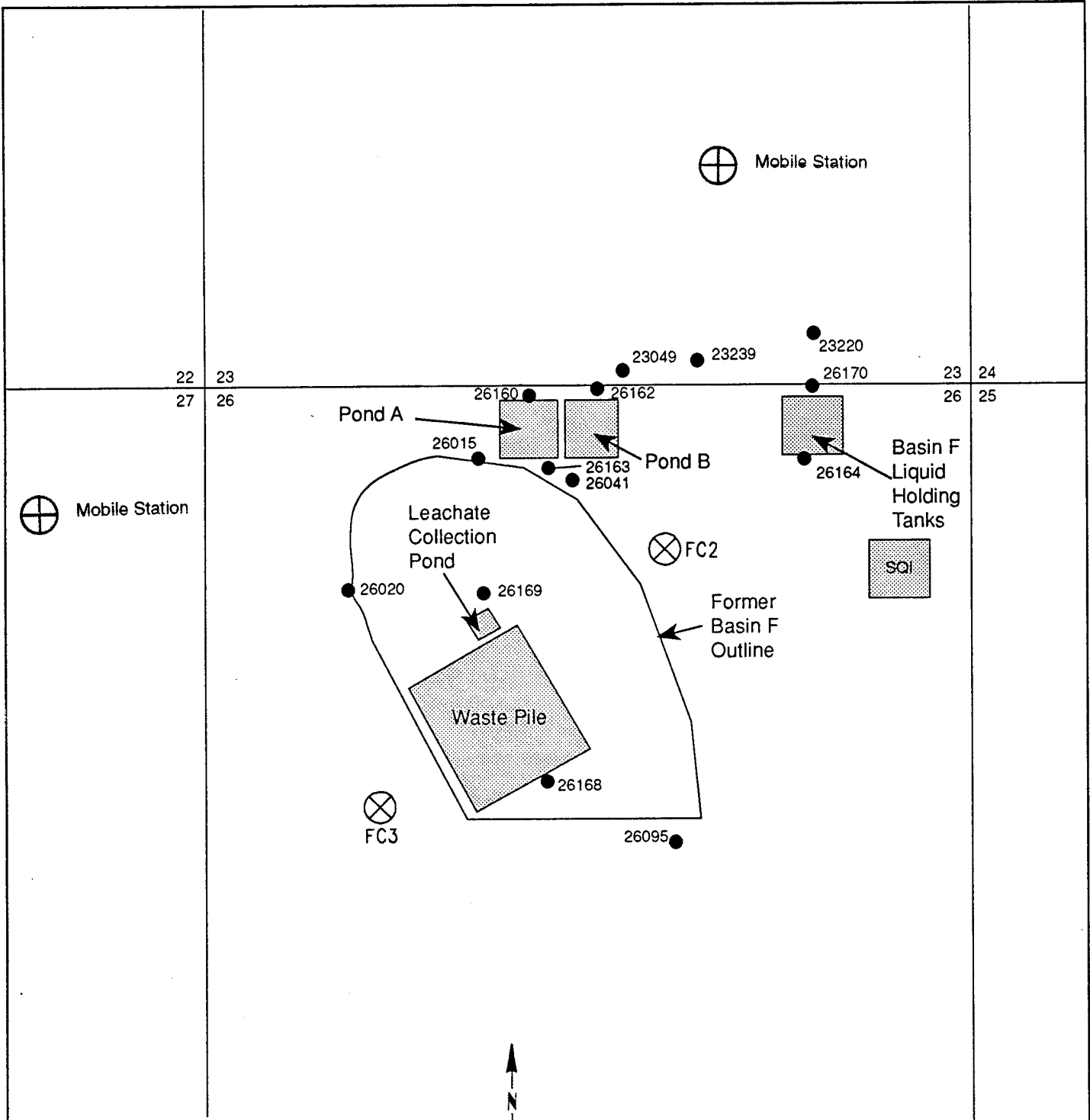

EXPLANATION

- Unconfined flow system well
- ▨ Basin F IRA structures
- ⊗ Fixed Air Monitoring Stations
- ⊕ Mobile Air Monitoring Stations

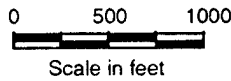

Source: Modified from R.L. Stollar and Associates, Inc. and others, 1990

Prepared for:
 Program Manager for
 Rocky Mountain Arsenal
 Commerce City, Colorado

Prepared by:
 RUST TERC 1 Team

Figure 2.3-1
Quarterly Basin F Groundwater Quality Monitoring Well Locations and Air Quality Monitoring Stations

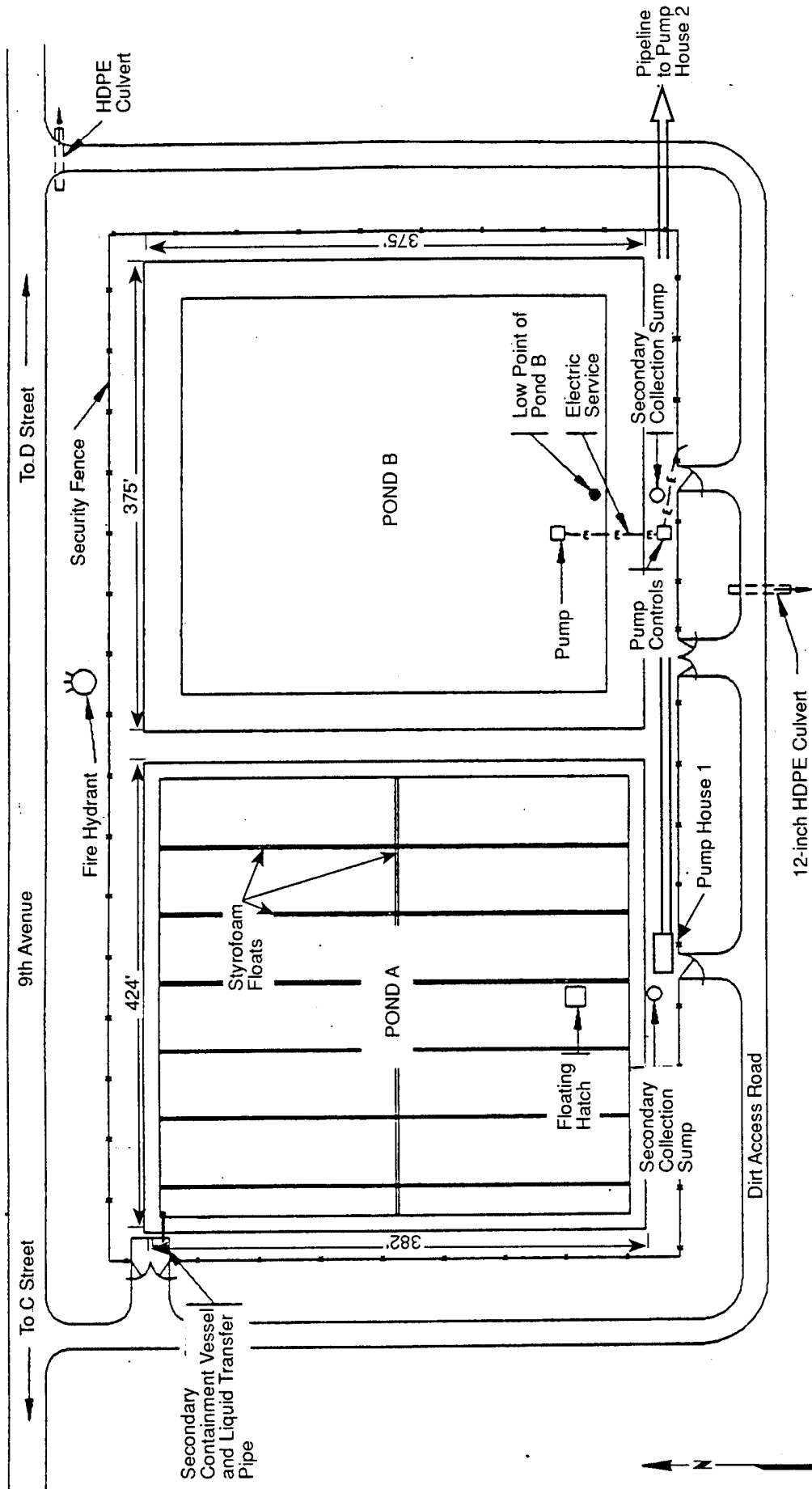

Explanation

HDPE High-density polyethylene

Not to scale

Source: Roy F. Weston, January 1990

Figure 2.5-1
Basin F Ponds A and B

Prepared for:
Program Manager for
Rocky Mountain Arsenal
Commerce City, Colorado
Prepared by:
RUST TERC 1 Team

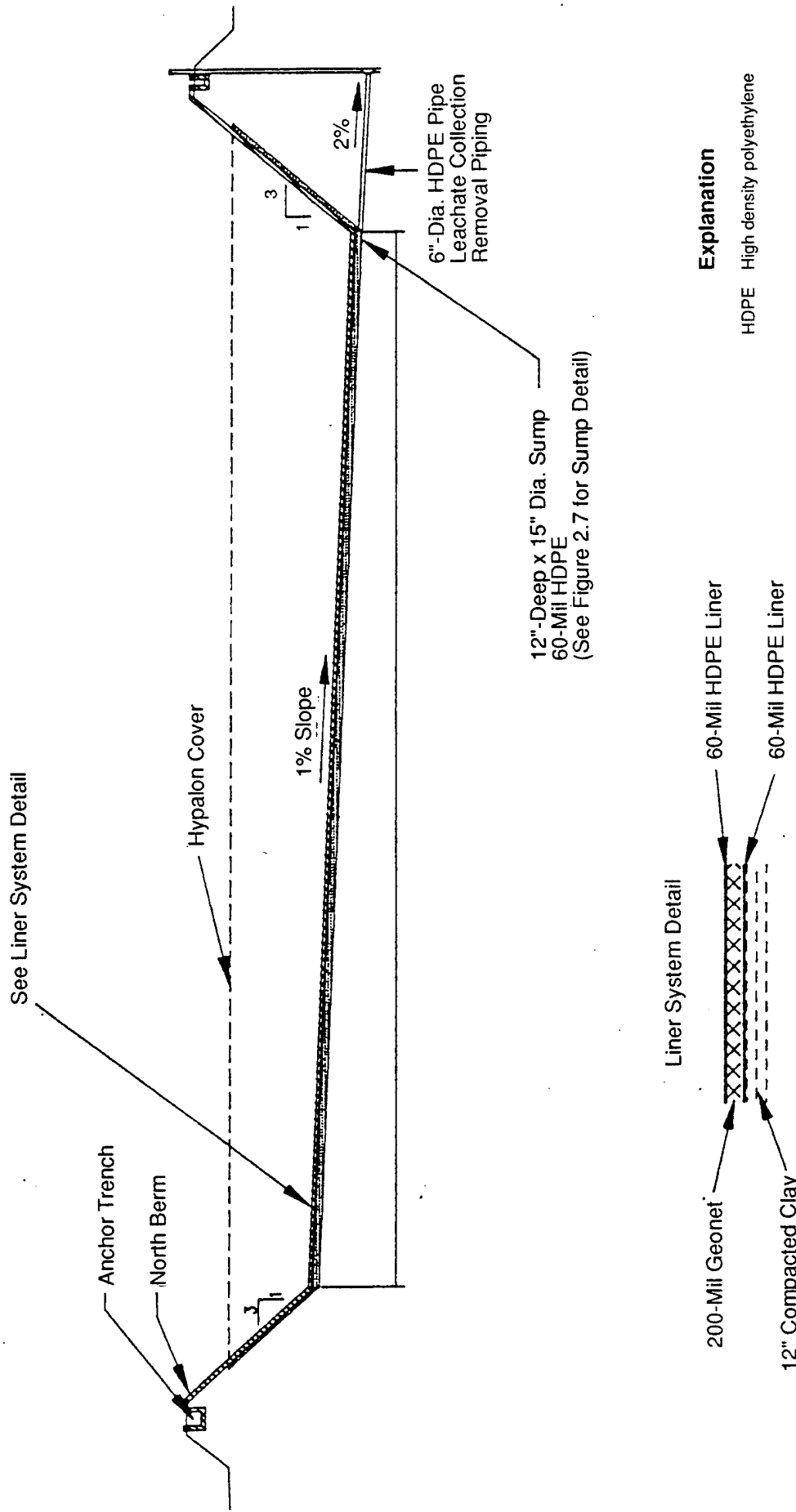
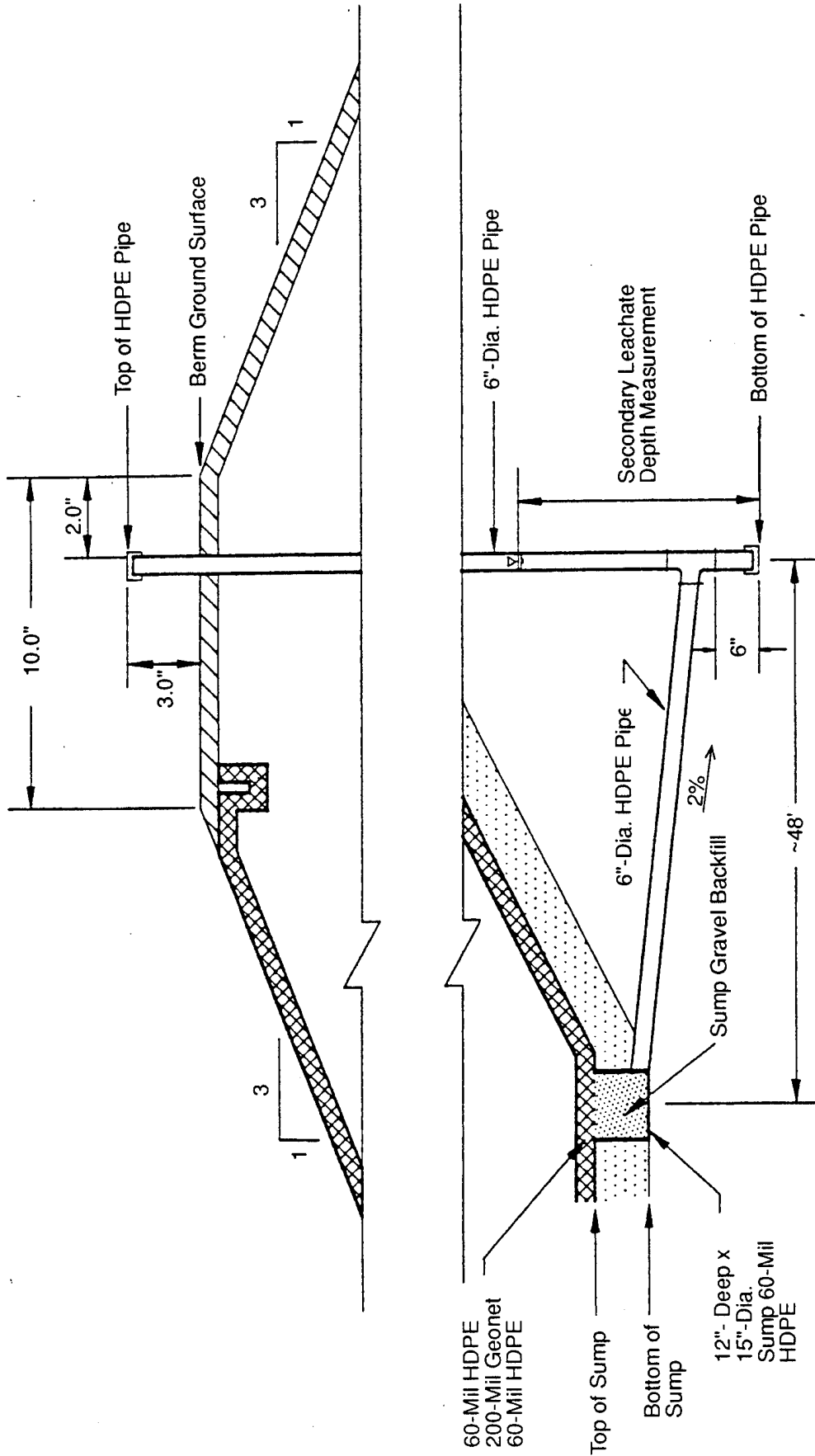

Figure 2.5-2
Representative North-South Pond Cross Section

Prepared for:
 Program Manager for
 Rocky Mountain Arsenal
 Commerce City, Colorado

Prepared by:
 RUST TERC 1 Team



Explanation

HDPE High density polyethylene

Figure 2.5-3
Pond Leachate Collection and Removal System Details

Prepared for:
 Program Manager for
 Rocky Mountain Arsenal
 Commerce City, Colorado

Prepared by:
 RUST TERC 1 Team

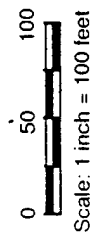
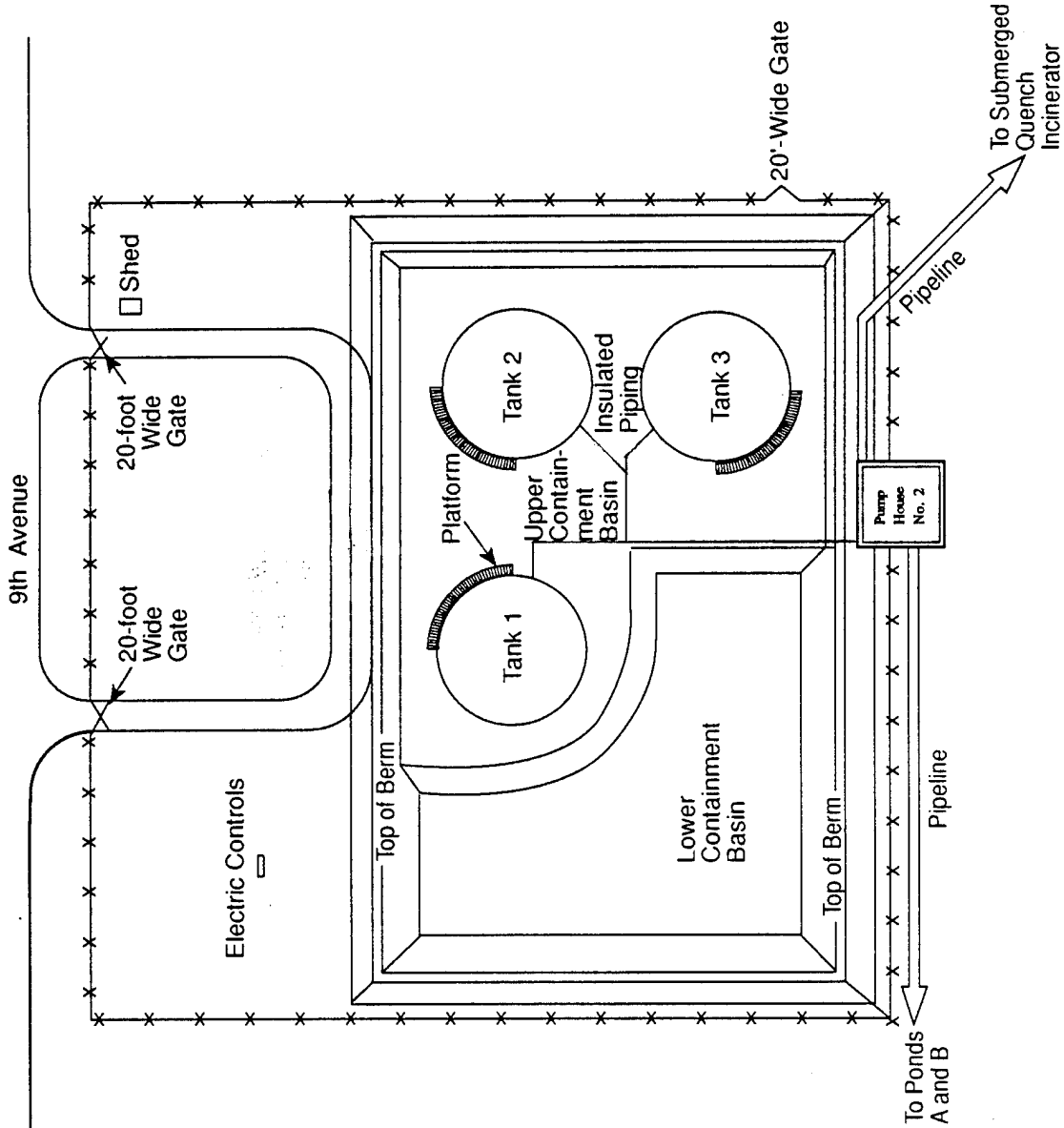

Source: Roy F. Weston, January 1990

Figure 2.5-5
Basin F Tank Farm Plan

Prepared for:
Program Manager for
Rocky Mountain Arsenal
Commerce City, Colorado
Prepared by:
RUST TERC 1 Team

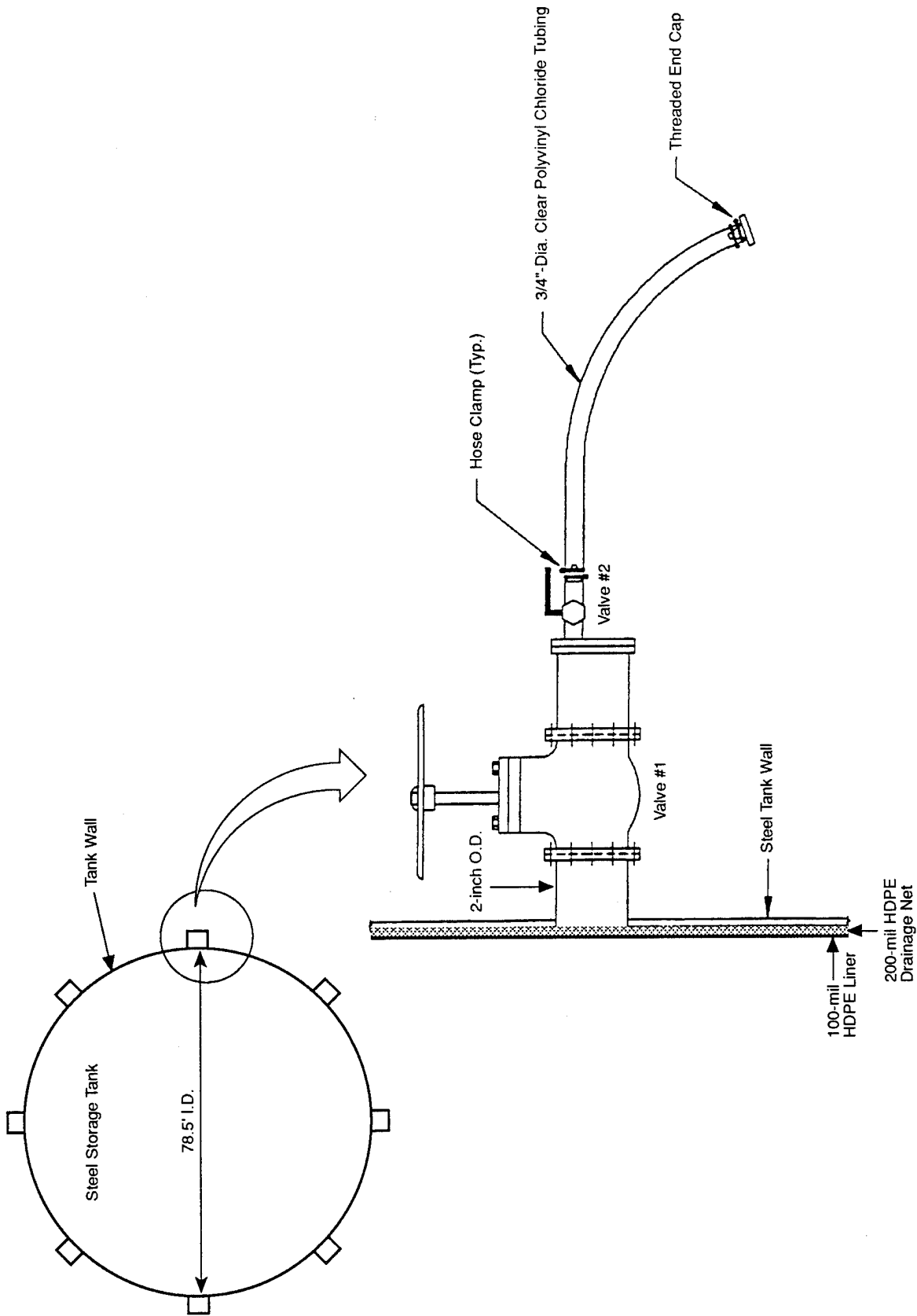
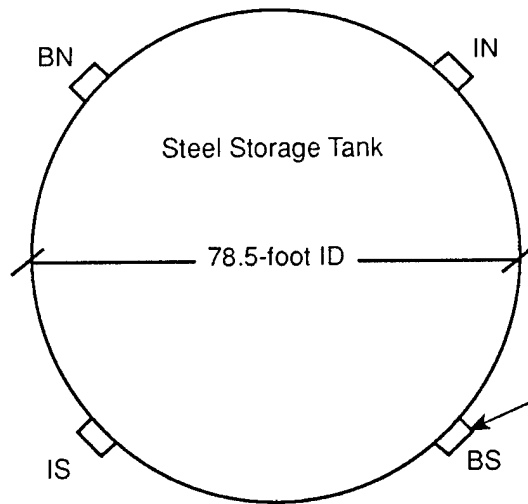
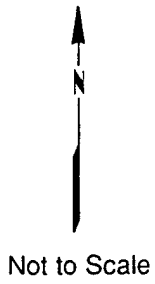

Figure 2.5-6

Typical Leak Detection System for Basin F Tank Farm Storage Unit

Prepared for:
Program Manager for
Rocky Mountain-Arsenal
Commerce City, Colorado
Prepared by:
RUST TERC 1 Team



Explanation

- BN = Bottom north
- BS = Bottom south
- IN = Interior north
- IS = Interior south
- ID = Inside diameter

Test Hubs

PLAN VIEW

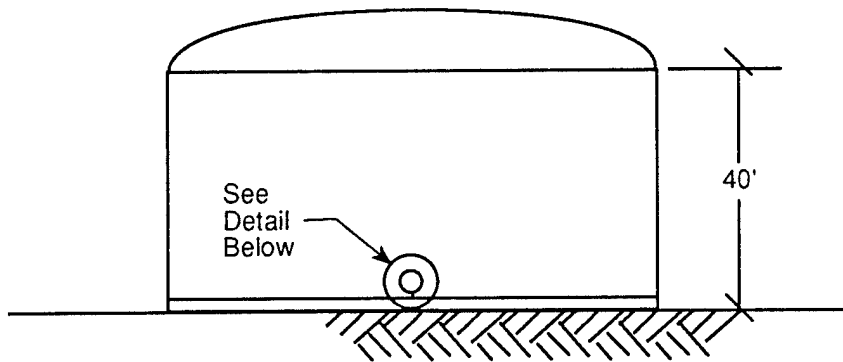

PROFILE VIEW

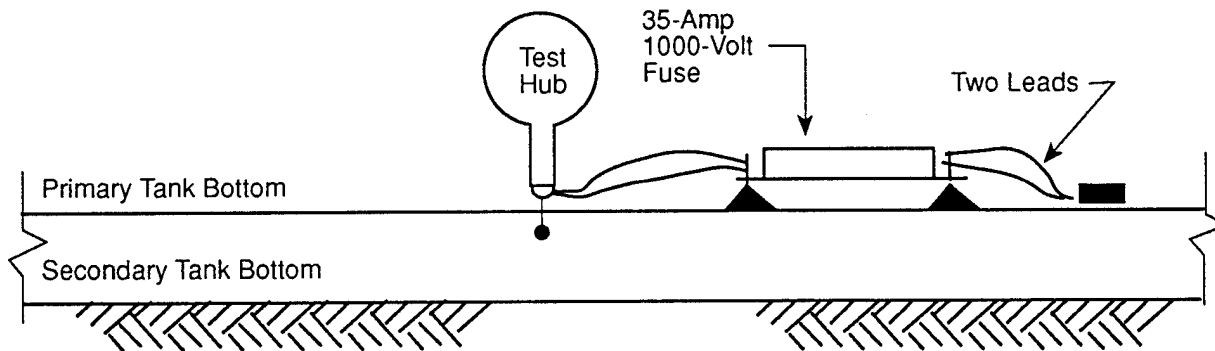

Source: Roy F. Weston, January 1990

Prepared for:
Program Manager for
Rocky Mountain Arsenal
Commerce City, Colorado

Prepared by:
RUST TERC 1 Team

Figure 2.5-7

Cathodic Protection Test Hub and Fuse Location

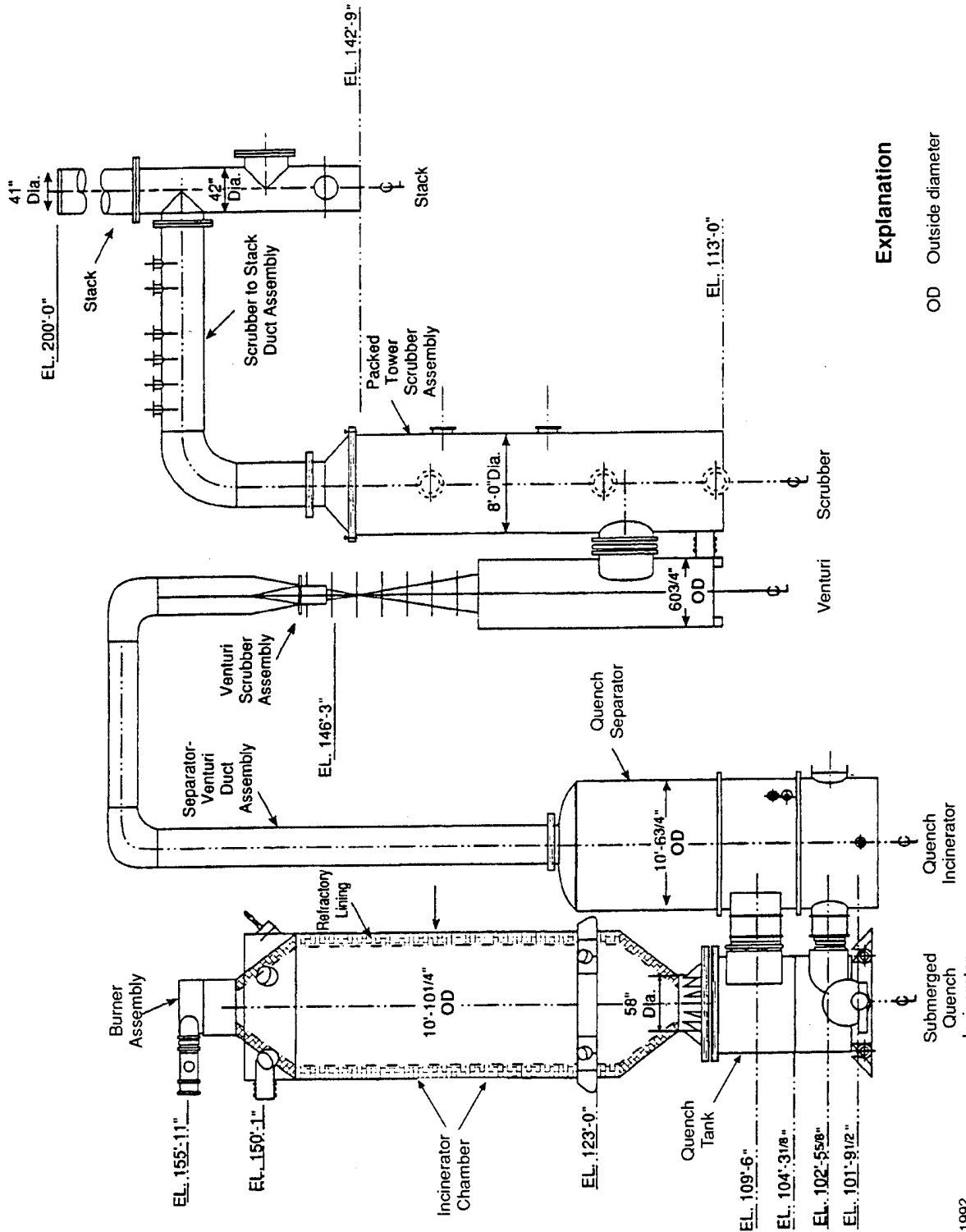

Figure 2.5-8
Submerged Quench Incinerator
and Emission Control Design

Modified from Weston, 1992

Prepared for:
 Program Manager for
 Rocky Mountain Arsenal
 Commerce City, Colorado
 Prepared by:
 RUST TERC 1 Team

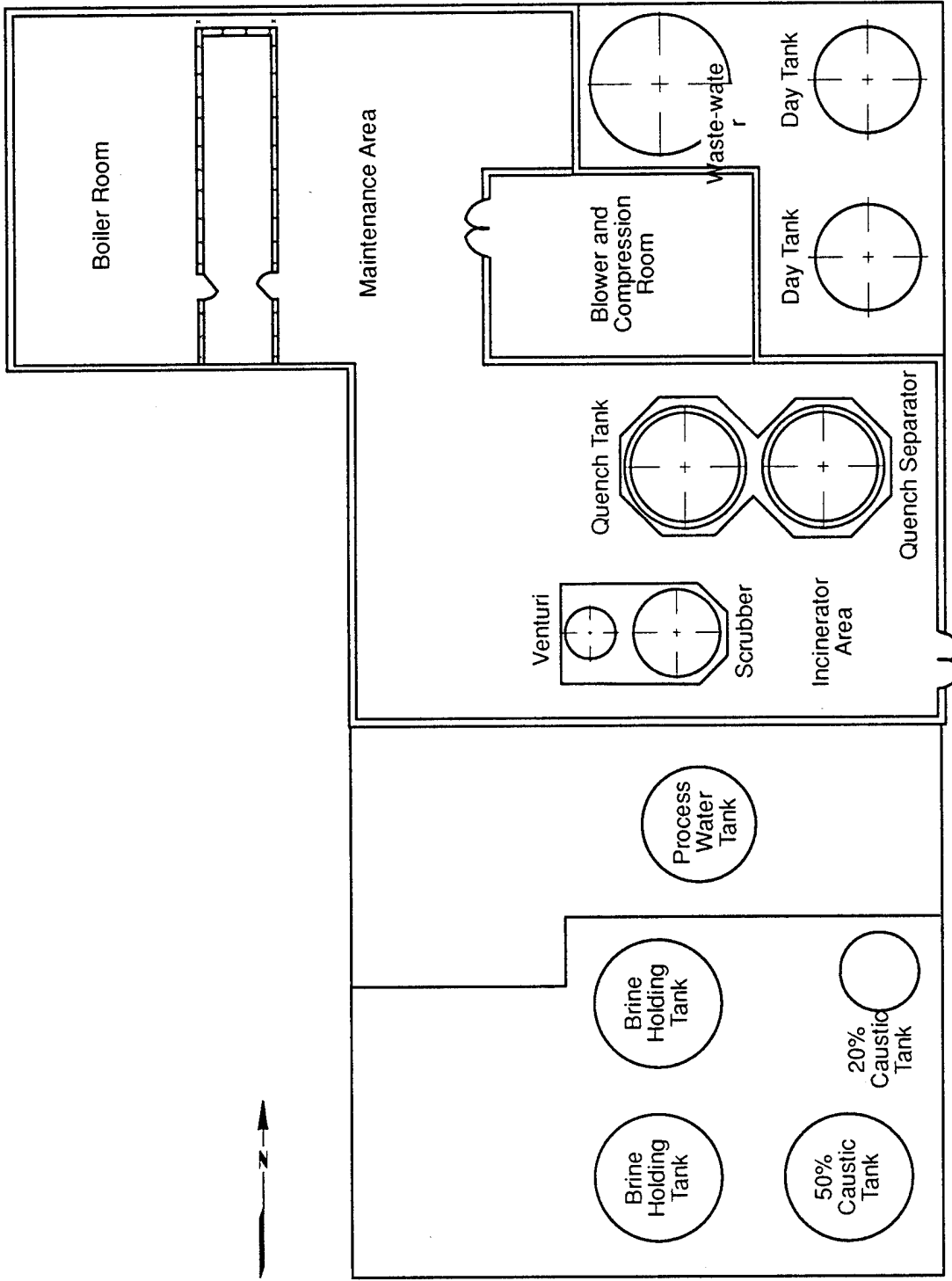

Figure 2.5-9
Submerged Quench Incinerator Building Plan

Prepared for:
Program Manager for
Rocky Mountain Arsenal
Commerce City, Colorado
Prepared by:
RUST TERC 1 Team

3.0 CLOSURE PROCEDURES

Closure activities will be conducted to meet the closure standard specified in 6 CCR 1007-3, Section 265.111 and Sections 265.228 (ponds), 265.197 (tanks), and 265.51 (SQI). Consequently, this Closure Plan describes procedures for clean closure of the Structures that minimize the need for further maintenance. Moreover, this plan describes measures that control, minimize, or eliminate, to the extent necessary to protect human health and the environment, postclosure escape of hazardous waste, hazardous constituents, leachate, contaminated runoff, or hazardous waste decomposition products to groundwater, surface water, or to the atmosphere. Because the Structures will be clean closed, a postclosure plan is not required and postclosure care is not necessary.

3.1 WASTE INVENTORY AT CLOSURE

The following sections describe the wastes managed and produced during Structures operations and maintenance, and provide estimates of the maximum quantities produced.

3.1.1 Bulk Waste

Ponds A and B

During its active life, Pond A held approximately 6.5 million gallons of Basin F liquid, and Pond B has been empty since 1988. Pond A contains a thin layer of residue on top of the primary liner, as discussed in Section 2.6. The volume of residue has been computed to be approximately 2,400 cubic yards, based on a layer 3 to 12 inches thick over the pond bottom. At the time of closure Pond A will not contain pumpable liquids, and the residue in Pond A will be dissolved and treated in the SQI as part of the closure of Pond A.

Tank Farm

The maximum inventory of Basin F liquid ever stored at the Tank Farm is approximately 4 million gallons. At the time of closure, there will be no pumpable liquid in the tanks. Once the Basin F liquid is removed from the tanks, a layer of residue will be left on the tank bottoms. Studies were performed by the Army to determine the volume of residue that may exist inside

Tanks 101 and 103 as discussed in Section 2.6. The residue depth, residue volume, and temperature results obtained are shown in Table 3.1-1. As discussed in Section 2.6, the solid residues were removed from Tank 102 during the pilot-scale field demonstration project.

3.2 CLOSURE PROCESS

The closure process for the Basin F IRA Structures consists of four phases of work: decontamination, removal, restoration, and certification. As shown in Figure 3.2-1, each phase comprises one or more tasks, for a total of seven tasks. The Basin F Structures closure process, and a description of each task, is described in detail below.

3.2.1 Decontamination Phase

The Decontamination Phase comprises two tasks: Task 1 - Preparation, and Task 2 - Decontamination. Task 1 includes the activities necessary to begin the decontamination task at a particular unit, such as removal of the ballast system on the Pond A cover and the installation of air treatment and decontamination equipment. Task 2 consists of the dissolution of residues and decontamination of contaminated equipment and materials at the Basin F IRA Structures.

Task 1 - Preparation

Ponds A and B

Task 1 activities for Ponds A and B will consist of mobilization and site preparation. Mobilization activities will include procuring required equipment, materials, and supplies, and transporting these items to the site. Off-site fabrication of the dissolution mixing system should be anticipated also. The site preparation activities will consist of physical alterations to accommodate project equipment, processes, and access controls; as well as the installation of utilities and closure process equipment (mixing system, air scrubber).

Tank Farm

The preparation task for the Tank Farm will begin once the mobilization activities have been completed. The Tank 102 effluent air scrubber system, installed to support the field decontamination demonstration, will be utilized in conjunction with Tank 101/103

decontamination efforts. This tank air-purging and treatment system, winterized and left installed at the tank farm during demobilization from the demonstration project, will be operated in conjunction with any intrusive activity in the tank to remove and replace multiple volumes of the tank atmosphere. This air system effectively reduced the toxic environment existing in the tank following the removal of the Tank 102 liquid, and during the crystal residue and liner removal/cleanup phase. The system basically consists of a blower unit, a series of granular activated carbon filters, an acid scrubber, and a chemical additive system. With the system in operation, a small negative pressure is created in the tank with air flow directed through the treatment system and eventually discharged to the environment. This system purges the tank of fumes and prevents uncontrolled discharges to the atmosphere. Some ductwork modifications will be required during mobilization in order to adapt the air treatment system to Tanks 101 and 103.

SQI

The preparation task for the SQI will include the installation and assembly of decontamination areas equipment and establishment of a water supply for the decontamination process. This task also entails coordination with SQI operations to ensure equipment and access requirements are understood.

Task 2 - Decontamination

Ponds A and B

The decontamination process for Ponds A and B generally includes removal of the Pond A cover and dissolution of residues in the surface impoundments. Removal of the Hypalon cover from Pond A will start from the highest point of the pond on the north end. The cover will be cut near styrofoam floats on both sides and along the anchor trench on top of the perimeter dike. The ribs will remain in place to provide containment during decontamination and removal of the first panel. The residue will be removed with conventional earthwork equipment and the residue will be transferred to a dissolution system which includes odor/vapor collection and treatment.

Pond A will be divided into approximately 50 foot wide strips (north to south) and into approximately 50 foot wide panels (east to west) as shown in Figure 3.2-2. The size of the actual exposed working surface will vary based on the efficiency of the field crew and the removal of the Hypalon cover will start with Panel 1 and work east in a sequential pattern. A labor crew in the appropriate level of PPE will move into the pond on top of cover panel 1 to collect and store existing sediments on the surface of the cover. Once the panel is free of sediments the crew will cut and roll back an approximately 10 foot by 50 foot slice of Panel 1 (Figure 3.2-2) The underside of the cover will be steam cleaned to remove residue that may adhere to the cover.

It is intended that residue on top of the primary liner in the exposed slice will be removed using small excavation equipment (e.g. Bobcat, skid loader) equipped with a non-metallic bucket. The labor crew will assist as appropriate to ensure minimal potential damage to the liner. The excavated residue will be loaded into sizing equipment (e.g., hammermill, crusher) or directly into the mixing equipment (depending on the physical properties of the materials being excavated). The sizing equipment will mechanically reduce the size of the residue down to approximately 1/4 inch, if required. A predetermined amount of residue will then be discharged into a dissolution mixing tank. The lid of the tank will then be closed and sealed. The valve to the air treatment system will be opened and a predetermined amount of clean, hot water (at a predetermined temperature) will be added to the tank. A mixer will be turned on, and the residue/water mixture will be stirred for a predetermined period of time. The resulting dissolution liquid will be pumped to the Pond A Pumphouse No. 1 and then pumped to one of the two remaining tanks in service at the Tank Farm (T101 or T103). Concurrent with the dissolution fluid discharge, the tank will be purged through the air treatment system before the tank lid is opened. Following the tank purge, all valves will be closed, the tank lid opened, and the entire dissolution process will be repeated with the next batch of residue.

After the cover slice and the exposed primary liner beneath have been cleaned, the cover will be cut along its approximately 50 foot length and removed in pieces. The removed solids will be placed in a container for off-post transportation (e.g. rolloff). The resulting pieces of cover

will be moved to a staging area in the pond, further decontaminated as needed, allowed to air-dry completely, and loaded into a rolloff container. The sleeves containing the styrofoam floats will be removed and placed in roll-off containers. The floats and the interior of the sleeves will be spray washed if Basin F liquid is found in the sleeves. All materials will be placed in the roll-off, or other appropriate transportation container, and will be disposed of at an offsite RCRA-permitted facility.

Tank Farm

Decontamination of the tanks will generally include dissolution of residues in the tanks and decontamination of tanks walls, ceilings, and other structures. Before manways are opened to determine the remaining residue volume in the tank, the annular space between the tank liner and wall must be drained of Basin F liquid that may be present in the leak detection system to prevent potential spillage when the manway is opened. Suction hoses will be attached to the existing annular drain ports around the base of the tank to remove trapped liquid. The use of suction hoses and pumps will reduce the potential of spills. The liquid will be collected and incinerated at the SQI.

After as much of the trapped annular liquid is removed as possible, one of the two manways will be opened to inspect the tank contents, with respect to remaining fluid/residue in the tank. If the volume of residue remaining in the tank is relatively small and the residue appears to consist of the readily dissolved variety, hot pressure washers will be used to dissolve the soluble residue. However, if the residue volume is found to be large (i.e., in agreement with initial estimates), and it appears to mirror the dissolution resistant materials encountered during the Tank 102 demonstration project, the residues will be removed with manual and mechanical methods, and the mixing process discussed for dissolution of Pond A residues will be utilized. In addition to assessing tank conditions, all apparent free liquid remaining within the tank will be pumped off at this time and transported to the SQI for incineration. An emission control system will be operated during this portion of Task 2.

The next step of Task 2 will be to cut a large access portal to provide free access and easing of confined space entry restrictions. This portal location will preferably be at the existing manway. Personnel will enter the tank after the air treatment system is engaged to remove any residue as well as the liner and geonet from the tank wall behind the area where a large access portal will be cut. Enough liner and geonet will be removed from the access portal area so as to eliminate the possibility of igniting the liner or geonet during hot cutting of the access portal. In addition, a fire-retardant barrier could be erected immediately behind the access portal to deflect molten slag and sparks during the hot cutting operation. Lighting will be installed in the tank, if needed.

If the volume of the remaining residue in the tank is relatively small, it will be manually concentrated (with shovels or squeegees) into areas by construction of retaining "pool" areas, as necessary. The retention pool areas may be constructed using rolled polyethylene sheeting or other means. The polyethylene will be disposed in the same manner as the liner and the geonet at completion of the project. Hot pressure washers will be directed at the concentrated piles of residue in the retention pools to produce residue dissolution. The pressure washers are typically capable of producing enough agitation and heat (approximately 180°F) to dissolve the residual materials. The resultant dissolution fluid will be removed with suction lines and pumped to temporary holding tanks for transport to the SQI for incineration.

If the assessment of tank conditions indicates a volume of residue in agreement with current estimates and exhibits characteristics similar to those found in Tank 102, the mixing system detailed for Pond A residue dissolution will be adapted for use. Once free liquid is removed from the tank and the large access portal is cut, residue will be broken into manageable pieces for transfer to mechanical sizing equipment, if required, for appropriate size reduction or to the mixing system for dissolution as described for the Pond A residue. Upon completion of the dissolution cycle, the fluid will be transferred to the SQI for treatment. Air treatment equipment supplemental to the main tank air scrubber will be utilized to control potential emissions from the dissolution process. The particular equipment needed for residue sizing and handling within

the tank and for transfer to the dissolution mixing system will be dependent upon tank conditions encountered.

Once all residues and free liquid have been removed, the HDPE liner and geonet leak detection system will be removed from the floor of the tank, rinsed to remove visible residue, air dried completely, and placed into a roll-off box for disposal at an off-site hazardous waste landfill facility (Task 3). With the tank floor free of liner materials, a stable working surface can be provided in order to mobilize a scissor platform to enable rinsing of the tank wall liner sheeting. Once decontaminated, the HDPE liner and geonet will be removed as discussed under Task 3.

Using the scissor platform and steam cleaner systems, a crew will steam clean the inside of the steel walls of the tank. Starting at the top of the tank wall, the entire tank wall surface will be steam cleaned in a standard pattern. Pending performance data from the Tank 102 demonstration, it is planned that the interior tank walls will be steam cleaned three times. Following steam cleaning of the walls, the tank floor will be steam cleaned in a sequential pattern. In the final steam cleaning, the cleaning pattern will extend up the tank walls and overlap the wall and floor seam. Rinse water will be collected in the tank floor sump system and pumped to the SQI for incineration. The aluminum dome roof will be decontaminated using high pressure washing equipment accessed by using the scissors lift.

SQI

The decontamination task for SQI will begin when SQI operations release the facility for closure. The SQI operations will leave the systems in a safe condition by flushing piping, tanks and process equipment. In addition, SQI operations will manage the process fluids (Basin F liquids, caustic, etc.) to ensure that minimal quantities of process fluids will be left to dispose during closure.

Because the SQI is a closed treatment process, the external surfaces of process equipment and piping, as well as the internal surfaces of the incinerator building are not expected to be contaminated by contact with process liquid and do not require extensive decontamination. The

internal surfaces of utility system equipment and piping are not exposed to process fluid and do not require any internal decontamination. Auxiliary equipment and utility piping that is not contaminated by contact with process fluid will not be internally flushed or rinsed. Auxiliary equipment that is physically isolated from the operating area, will not be externally washed. Tables 3.2-1, 3.2-2, and 3.2-3 list equipment and areas that fall into the internal-rinse, external-rinse, and no decontamination categories, respectively.

Piping and equipment surfaces exposed to Basin F liquid, brine, and process chemicals will be decontaminated to remove any Basin F liquid and brine residue. The washwater generated during the decontamination sequence and the final volume of water drained from the SQI equipment will be transferred to the metal reclaiming facility.

The process equipment and supporting structures will be decontaminated using a "worst first" sequence. The process equipment will be rinsed by high-pressure washing with hot water. Associated piping and pumps will be flushed by recirculation, and the washwater will be transferred to the wastewater tank for transfer to the metal reclaiming facility. The final liquid inventory of the process equipment and piping will be drained to the sumps and accumulated in the wastewater tank for transfer to the metal reclaiming facility.

After the decontamination process, equipment and large bore piping will be opened and visually inspected to confirm the effectiveness of the cleanup (Task 3). The small-bore process piping that cannot be internally inspected will be assumed hazardous and managed as a hazardous waste.

3.2.2 Removal Phase

The Removal Phase is made up of two tasks: Task 3 - Demolition, and Task 4 - Dismantling. Task 3 includes such activities as the cutting and removing of liners and demolition of foundations. Task 4 includes dismantling of unit components, such as piping and fences, and unit structures, such as tank and building shells. Dismantling activities are performed to optimize salvage and to allow for reutilization of components, processes, and systems.

Task 3 - Demolition

Ponds A and B

Removal of the containment structures for Pond A will begin after the cover and residue have been removed from Pond A and the top of the primary liner in Pond A has been spray washed to remove any remaining gross contamination. The underside of the primary liner will be spray washed to remove any visible contamination and residue that may have formed in the leak detection drainage net and that have adhered to the liner. The removal tasks for Pond B will essentially be the same as those for Pond A and are described below.

PRIMARY LINER. The removal of the primary liner will proceed in a manner similar to the Hypalon cover starting from the north side and working south down the pond bottom slope. A liner slice will be cut on three sides and rolled back onto the remaining primary liner. The underside of the slice will be sprayed with hot water to remove any Basin F liquid or residue. Wash water will be allowed to flow on top of the primary and secondary liners to their respective sumps. Spraying will be performed to minimize splashing Basin F liquid or residue on the upper side of the panel being removed or onto the adjacent panels. After decontamination and removal of the geonet (which is detailed below), the final side of the slice of liner will be cut and the entire slice removed. The resulting piece of liner will be further cut, carried to a staging area in the pond, further decontaminated as necessary, allowed to air dry completely, and loaded directly into a roll-off disposal container for disposal in an off-post RCRA-permitted facility. The next slice of primary liner will then be cut and the process repeated.

GEONET. Removal of the drainage net will parallel the removal of the primary liner. The drainage net will be cut along the anchor trench at the top of the dike surrounding the pond. The nylon ties that hold the individual geonet sections together will also be cut. The drainage net will be spray washed as it is removed and the water allowed to drain to the sump. If residual crystals are found in the geonet they will be collected and fed into the mixing tank as described for Task 2. When the crystals have been removed the geonet will be transferred to a cleaning station near the pond sump and washed to complete the decontamination process. The generated liquid will be allowed to flow into the pond sump for transfer to the SQI. Provisions

will also be made for pumping this liquid if required (Pond B). The geonet will then be loaded directly into a roll-off disposal container for disposal in an off-post RCRA-permitted facility.

SECONDARY LINER. Visible contamination on the top of the secondary liner will be spray washed. The wastewater will be collected in the pond sump and pumped to the SQI. Before removal of the secondary liner begins, the entire secondary liner will be inspected for rips, tears, or perforations that would have allowed Basin F liquid to contaminate the underlying soil during operation of the pond. Identified damages will be surveyed to establish location and to allow the locations to be reestablished after the secondary liner is removed.

Removal of the secondary liner will begin once all of the primary liner and geonet have been removed and will start from the highest points of the pond, which are at the northeast and northwest corners. The liner panels will be cut along the anchor trench and along the seams. The liner will be further cut into a size appropriate for disposal. The underside of the liner will be scraped during removal to remove any soils adhering to the liner. The pieces will be verified to be completely dry and placed in a roll-off container for disposal in an off-post RCRA-permitted facility.

Tank Farm

Using scissor platforms, the tank wall liner will be cut into vertical strips of a manageable width. Utilizing lessons learned from the Tank 102 demonstration, these vertical strips will be cut horizontally approximately 1 foot from the liner attachment ring at the top of the tank wall. This will be necessary as the HDPE clamps can be anticipated to be heavily corroded. As the strips are cut horizontally they will be dropped to the floor one strip at a time. The HDPE liner strips will then be laid out flat on the tank floor and pressure washed on the back side to remove residue, if required. Once decontamination is complete, the liner will be cut to appropriate size, allowed to air dry completely, and placed in a roll-off container for disposal. For those areas of the tank wall that have a 200-mil HDPE geonet behind the liner, the same washing process used on the liner will be used on the geonet (i.e., washed from scissor platforms, cut vertically in strips and horizontally near the top of the tank, dropped to the floor, laid out, washed again,

air dried, and placed in a roll-off container for disposal). Pneumatic tools will be used to free the clamps holding the remaining liner at the top of the tank wall.

The HDPE liners will be removed in sequence starting at any point in the tank and working adjacent strips in series until the entire tank perimeter is completed. Decontamination washwater will be collected in the tank floor sump pump system and pumped to holding tanks for SQI incineration. Liner and geonet pieces will be transported to an appropriate off-post RCRA-permitted facility for disposal.

The concrete tank foundations will be demolished and loaded into roll-off containers or end-dump trucks once Task 4 (dismantling) has been completed. The soil on top of the 100-mil HDPE secondary containment liner will be excavated with a front-end loader or backhoe. The 100-mil HDPE secondary containment liner will then be cut into appropriate sections and placed in roll-off containers. The liner material will be disposed in an appropriate offsite permitted RCRA facility. The soil above the liner will be sampled in order to determine the appropriate facility for treatment or disposal.

Task 4 - Dismantling

Ponds A and B

Equipment and materials removed in Tasks 3 and 4 will be decontaminated using a high-pressure wash. Associated piping and pumps will be flushed with the hot washwater, and the wash water and will be pumped to the SQI for incineration.

The pond sump is a 12-inch-deep by 15-inch-diameter HDPE prefabricated sump which is filled with drain gravel. Leachate will be removed through a 6-inch-diameter HDPE pipe that is fusion welded to the sump. The lateral pipe is approximately 45 feet long and slopes down and away from the sump at a 2 percent grade. The end of the lateral pipe is attached with a "tee" to a 15-foot vertical riser pipe. The top of the riser pipe is 3 feet above the top of the berm and 5 feet outside the edge of the berm. The leachate removal pump sits inside the "tee."

An excavation will be made to expose the pond sump system. The sump and piping will be removed from the excavation and spray washed with hot water to remove any residual contamination. The debris will be placed in a roll-off container. During the excavation, any visually contaminated soil will be noted at the location surveyed and mapped for sampling in Task 5.

The pumps and piping associated with Pumphouse #1 will be flushed with hot water. The exterior surfaces of the structure, concrete, wiring, and piping will be spray washed. Pumphouse #1 and the piping to Pumphouse #2 will be dismantled. Any equipment or materials that are to be salvage/reused will be placed in a roll-off container or end-dump for recyclable materials. Materials not to be salvage/reused will be placed in a roll-off container for transport to an appropriate off-site permitted RCRA facility. All foundation concrete will be excavated and placed in a roll-off container for disposal.

The fences will not be removed until after the demolition activities so that site access can be controlled until the ponds are decommissioned. The barbed wire fence will be removed from the brackets and rolled onto wire spools. The chain-link fencing fabric will be removed from the poles, rolled up, and strapped. All hardware and brackets will be removed and crated. The fence poles will be removed, and the concrete bases will be broken off. The barbed wire, chain-link fencing, poles, and hardware will be removed to a temporary decontamination area, decontaminated, if required, using a high-pressure, high-temperature spray wash, and placed in a roll-off container for salvage/reuse. The pieces of the concrete bases will be transported to a RCRA-permitted disposal facility.

The Hypalon cover, primary liner, geonet and secondary liner sections will be excavated from the perimeter anchor trenches. Excess soil will be scraped from these liner components, and these components will be placed in a roll-off container for disposal in a RCRA-permitted facility.

Tank Farm

Once dry and accepted as decontaminated, the aluminum dome will then be detached from the tank walls, lifted in its entirety from the tank, and placed in a prepared area outside the

exclusion zone. Once the roof dome is decontaminated and removed from the tank, the roof dome will be dismantled in sections and packaged for salvage.

After the roof is lifted off of the tank, the tank air control system and the crystal dissolution process trailer will be relocated to the next tank or decontaminated for project demobilization. The tank floor sump pumping system will remain in place for final decontamination activities.

Following final washing, the steel tank shells and aluminum dome roofs will be evaluated for disposal options. The optimum disposal solution for these tank components is to send them to a recycler to be melted for re-use.

Before decontaminating the piping, valves, Pumphouse #2, and other ancillary systems associated with the tank operation, an inventory will be conducted to identify those components that have come in contact with Basin F liquid. Only those component systems that have come in contact with Basin F liquid will be decontaminated. Flushing and rinsing "tees" will be installed so that a triple-rinse using hot water can be conducted. System components that did not contact the Basin F liquid will be isolated from the rinsing and flushing process to prevent cross contamination. Flush water and rinse water will be collected and recirculated or incinerated in the SQI. After the rinsing cycle, the components having contacted Basin F liquid will be dismantled and transported to the wash pad for final steam cleaning as necessary. Following steam cleaning, the components will be air dried completely and packaged appropriately for disposal at an off-site permitted RCRA facility.

The fencing will be removed, spray washed, if necessary, and salvaged/reused. Removal of the fencing will come at the end of the closure activity so site access can be controlled until the project is concluded. The removal of the fencing will proceed in the same fashion described above for Ponds A and B.

The cleaning and rinse water for the entire decontamination and rinsing process for the Tank Farm components will be collected and either reused or incinerated at the SQI.

SQI

The demolition of the SQI will follow the most cost effective approach to separating the marketable utility equipment and process control components from the solid waste and hazardous solid waste streams. Even without reuse of the main process equipment, a large number of the control and utility equipment items can be resold using Army procedures. The continuous emissions monitoring system will be directly transferable to many other industrial installations, as will most of the components in the primary and secondary control panels. The electrical transformers and switchgear are also easily salvageable. However, the main items of process equipment and the process piping will be managed as hazardous solid waste.

The tankage in the waste liquid feed and byproduct brine storage areas will be dismantled first to allow crane access to the SQI building. Most of the tanks will be cut up and managed as hazardous debris unless there is an on post use for a tank or tanks. Tanks and piping will be managed as hazardous waste, while piperacks, ladders, and stairways will be managed as solid waste. In the case of process pumps, the pump bodies will be dismantled and managed as hazardous debris, the motors and couplings will be dismantled and recycled, and the baseplates will be managed as uncontaminated cast iron scrap.

Starting with combustion air and waste liquid feed systems, the potentially contaminated process piping between equipment items will be disconnected, cut into manageable pieces, and accumulated in roll-off containers for off-site disposal. Fiberglass reinforced pipe (FRP) will be crushed to reduce the transport volume, Hastelloy pipe sections and fittings will be taken to the equipment decontamination pad, pressure washed, and inspected. The process piping will be cut into manageable pieces and managed as hazardous debris. Table 3.3-3 indicates the weight and volume of the process piping that will be handled via these methods.

Dismantling and removal of the process equipment will commence as soon as the surrounding piping and conduits are removed. All potentially contaminated process equipment will be managed as hazardous solid waste. The hastelloy sections of the incinerator and quench vessels will be separated from the carbon steel sections, visually inspected, and recycled for their nickel

content. Carbon steel process vessels will be cut into manageable sections and disposed via a smelter. FRP process pumps will be crushed to reduce volume and disposed in a RCRA approved landfill. The FRP pipe will be rinsed prior to demolition, and the pipe and fittings will be visually inspected during disassembly.

The plant and instrument air compressors, the startup steam boiler, the firewater pumps, the water filter and softener, the electrical transformers, and the electrical switchgear in the motor control centers are uncontaminated and will be managed as surplus equipment. These items will be sold using Army procedures.

The main process building will be dismantled from the top down. Building insulation, metal siding, and roofing panels will be lowered to ground level and stacked for recycle. The heaters, fans, and louvers of the HVAC system will be dismantled, lowered to the ground, and transferred to storage pending resale using Army procedures.

After process equipment and piping are removed, sections of steel floor grating and the supporting steel framework will be dismantled on a floor by floor basis. The concrete block partition walls, the concrete floor decks will be demolished and the steel stairways will be disassembled. Except for the concrete floor slab and the concrete deck sections in the operating and maintenance areas, most of the SQI building components will be managed as industrial solid waste.

The SQI foundation slab and the containment area slabs will be examined for cracks and sampled for contamination as described in Section 3.2.3. Concrete sumps will be assumed contaminated, and removed and managed as hazardous debris. Given the two foot thickness of the SQI foundation slab, any surface contamination will be addressed by surface removal and the slab will be left in place to support a future remedial action.

SQI Support Buildings

Once the main process building is down, the control room, the change house, the switchgear building, and the firewater pump enclosure will not be in use but will be left in place to support any future remedial actions. Equipment from the control room will be removed and auctioned or salvaged. The support trailers will be left on site or used elsewhere on RMA. The diesel generator and fuel oil tank will be disconnected from utilities and left on site. The remaining utilities will be disconnected at the facility boundary but will be left intact. Concrete containment area slabs, control room and change house slabs, transformer and emergency generator pads, trailer pads, and asphalt paving will be left in place to support any future remedial actions. The electrical distribution system and exterior lighting will be left in place. The barbed wire fence associated with the SQI will be left in place to allow security to be maintained if the support buildings are used for a future remedial action.

3.2.3 Restoration Phase

The Restoration Phase, includes Task 5 - Soil Investigation and Task 6 - Earthwork. Task 5 includes soil sampling and analysis, evaluation, and identification of potentially contaminated areas. Task 6 includes activities such as the potential excavation of contaminated areas, backfill of excavations from foundation and liner demolition, and final grading. The restoration phase may also include the final seeding and mulching of the graded area.

Task 5 - Soil Investigation

The area potentially contaminated by the operation and maintenance of Pond A and Pond B is expected to consist of the area contained within the Pond A and Pond B berms and embankments extending no further than the 12-inch compacted clay layer below the Pond A and Pond B secondary liners and sumps. Confirmatory samples will be collected to assess the areal extent of contamination and the relative levels of contamination as described further in Section 3.4. Following the definition of soil contamination, should it exist, the contaminated soil will be excavated and placed into drums and/or roll-off containers or end-dumps for transportation to an appropriate off-site permitted RCRA facility.

Following the removal of structures and foundations in the Tank Farm, the soil below the 100-mil secondary containment HDPE liner will be tested for residual contamination, as described below in Section 3.4. Because a secondary containment system, consisting of a 100-mil HDPE liner, was used under the Tank Farm area, it is unlikely that contaminated soil will be encountered. However spill and response records will be reviewed and areas with past problems will be investigated. Following the definition of soil contamination, should it exist, the contaminated soil will be excavated and placed into drums and/or roll-off containers for transportation to an appropriate off-site permitted RCRA facility.

The SQI process areas will be inspected for potential areas of contamination after equipment and structure decontamination. Sumps and slabs will be inspected for cracks and adjacent soil will be sampled in failed areas and at the slab perimeters for contaminants of concern. Because of the secondary containment provided in storage tank areas and the housekeeping procedures followed during the operation of the SQI, it is unlikely that contaminated soil will be encountered. However, spill and response records will be reviewed and areas of past problems will be checked for contamination. Samples collected for analysis will be collected as described below in Section 3.4.

Task 6 - Earthwork

The methods for removing contaminated soil are dependent on the location, extent, depth, and characteristics of the soil contamination. Minimal surficial contamination may be removed manually with a shovel, while more extensive areas of soil contamination would require conventional excavation equipment such as a backhoe or front-end loader. All excavation equipment will be decontaminated by steam cleaning with the condensate collected, tested, and disposed appropriately.

Contaminated soil beneath Ponds A and B identified for excavation in Task 5 will be removed. It is estimated that the extent of potential contamination will not exceed the 12-inch compacted clay layer below the secondary liner and would probably be located near the sump system.

Therefore, the estimated volume of contaminated soil that may be removed for planning purposes is 1,000 cubic yards.

The quantity of contaminated soil beneath the Tank Farm will not be known until sampling and testing are completed. However, the volume is expected to be small based on the existence of the secondary containment liner system. The estimated soil volume for excavation is based on the removal of the entire 1 foot of soil cover on top of the secondary containment liner. Therefore, the estimated volume of soil that may be removed for planning purposes is estimated to be 7,000 cubic yards.

The quantity of contaminated soil beneath the SQI sumps will not be known until sampling and testing are complete; however, the volume is expected to be small based on the stringent operating inspections and spill control procedures. Based on the removal of 1 foot of soil from around the SQI sumps, a worst-case contaminated soil volume of 25 cubic yards will be used for closure planning.

After removal of the perimeter security fence, the depressions left by the structures will be backfilled with clean fill material and compacted. The area will then be graded to surrounding grade so that precipitation will not collect at the site. All disturbed areas will have vegetation re-established in accordance with U.S. Fish and Wildlife guidance.

3.2.4 Certification Phase

The last phase, Certification, is made up of a single task, Task 7 - Closure Certification. This task includes the inspection, documentation, and final certification by an independent professional engineer that closure meets the regulatory requirements.

Task 7 - Closure Certification

A certification that the structures have been closed in accordance with procedures specified in the approved Closure Plan and 6 CCR 1007-3, Section 265.115 will be submitted within 60 days of completion of final closure. The certification will be submitted to CDH by registered mail

and will be signed by the Army and by an independent registered professional engineer. Documentation supporting the certification of the independent registered professional engineer will be maintained on file by the Army.

An independent professional engineer may periodically observe closure activities onsite to ensure that the procedures outlined in the approved closure plan are being followed. A field report detailing the observations will be generated by the independent professional engineer for each onsite visit. The independent professional engineer will also review laboratory sample results, contractor logs of activities performed during closure, and as-built drawings of the facility. The findings of the independent professional engineer will be documented in report form, and a certification document will be prepared and submitted in accordance with 6 CCR 1007-3, Section 265.115 within 60 days of the completion of the closure activities.

3.3 PROCEDURES FOR HANDLING CLOSURE WASTE

Closure of the structures will include the removal, decontamination, and/or disposal of all hazardous waste and waste residues, containment system components, equipment, structures, and environmental media impacted by Basin F liquid. Hazardous waste generated during closure will be managed in accordance with the requirements of Resource Conservation and Recovery Act (RCRA) and Colorado Hazardous Waste Management Act (CHWMA). The following sections detail the management of waste material generated during closure.

3.3.1 Structure-Specific Wastes

Closure of the Structures will generate a number of waste streams. These will include foundations, equipment, components, piping, liners, soil, and decontamination rinse water. Tables 3.3-1 through 3.3-3 show the volumes of materials estimated to be generated for Ponds A and B, the Tank Farm, and the SQI, respectively. Table 3.3-4 is a material disposition matrix that summarizes the management of these wastes. Tanks, pipes, and other equipment that were in contact with Basin F liquid and cannot be verified clean will also be handled as a hazardous waste. Building debris contaminated with either listed hazardous wastes or that exhibit hazardous waste characteristics and are not able to be cleaned will be managed accordingly.

Soil, tank sludge, and waste residue will be managed as hazardous waste if they contain listed hazardous wastes or have hazardous waste characteristics. Decontaminated tanks, piping, and equipment will be salvaged or handled as solid waste. The SQI building structure and foundation debris will be managed as nonhazardous debris and will either be salvaged or disposed. The pipings and fittings that were in contact with Basin F liquid will either be salvaged or disposed at an off-post RCRA-permitted facility. All equipment and materials will be free of gross visible contamination prior to disposal or salvage/reuse.

3.3.2 Offsite Disposal

The Army has reviewed the following three options for the management and disposal of hazardous waste generated during closure: Option 1—disposal in place; Option 2—on post storage; and Option 3—off-post disposal. Based on an evaluation of each waste management option, the Army will dispense the closure wastes under Option 3. The evaluation for each option is briefly described below.

Option 1—disposal in place—was not selected because it does not provide adequate protection of human health and the environment and it does not meet the requirements specified in RCRA for disposal of hazardous waste. For example, hazardous waste cannot be disposed of in units that do not meet the RCRA performance standards specified in the regulations. Furthermore, disposing of the waste material on land constitutes placement that requires conformance with the land disposal restrictions (LDRs).

The two remaining options could all meet the requirements specified in the CHWMA regulations. However, Option 2—on post storage—was not selected as the preferred option because (1) it does not provide long-term protection, (2) it will increase exposure to workers and the environment because the waste material will be handled twice (once to place in storage and once to remove for final disposal), and (3) it will result in increased management costs due to the double handling.

Option 3—off-post disposal—was selected as the preferred option for disposal of the closure waste as this option will provide long-term protection. Non-hazardous structural material will be salvaged/reused or disposed as solid waste. Equipment and materials that will not be salvaged/reused will be disposed at an appropriate offsite permitted RCRA facility that can also accept wastes generated from a CERCLA site. Equipment and materials designated for disposal will be free of gross visible contamination and will meet applicable LDRs.

Closure of a process system includes the removal or decontamination of waste residues, containment system components, equipment, structures and soils exposed to the waste. In the case of

the SQI, the bulk liquid wastes will be processed through the unit until they are consumed or until the unit is shut down. Water will be used to flush the bulk of the waste residues from the SQI facility piping and equipment in a triple-rinse approach to facility decontamination.

After the SQI is released from operations, the incinerator will be decommissioned and its refractory lining will be removed. The hazardous and nonhazardous wastes generated in the remainder of the SQI closure process will be managed by appropriate means. These wastes include rinse water generated during process equipment and building decontamination, the debris generated during process and structure demolition, and any contaminated soil detected during the final certification of site decontamination and demolition. These wastes are summarized in Table 3.3-5.

3.3.3 Decontamination Verification Procedure

Closure of the Basin F IRA structures will generate a large quantity of structural material, scrap metal (e.g., tank shells) structural steel, and used equipment. Where appropriate, material will be decontaminated for salvage/reuse. Material that cannot be salvaged/reused will be disposed of as hazardous debris in a RCRA-permitted off-post facility. The Basin F decontamination procedure, high-pressure water/steam wash, will meet both the best demonstrated available technology (BDAT) for hazardous debris and the closure decontamination standard for structures and equipment. EPA stated in the debris LDR preamble that the treatment method for debris will always satisfy the decontamination standard in the closure provisions (57 Federal Register 37194). Consequently, confirmatory sampling of salvageable materials is not required by the regulations.

The Army will conduct verification sampling for decontaminated structural material as part of the Tank 102 Pilot Decontamination Field Demonstration project. At the time of the preparation of this document, wipe samples were proposed for the Tank 102 project to verify the adequacy of tank wall decontamination. Proposed sampling locations were as follows: 2 sample locations on the tank floors, 4 sample locations on the tank walls, and 2 sample locations on the tank roof. Sample locations will be selected in areas that appear to have the greatest potential to show contamination. Samples will be analyzed using the following methods: EPA method 8270 for

semivolatiles, EPA Method 8080 for pesticides, and EPA Method 6000 for metals. One wipe sample will be collected for each analysis (three per location). Each sample will be collected from an individual 100 centimeter square grid at the sample location. If the results show appropriate decontamination of the materials, no further verification will be performed during closure of the Basin F IRA Structures.

3.4 SOIL VERIFICATION SAMPLING PROGRAM

The following sections describe the clean-closure soil sampling verification program for the Basin F IRA Structures. Procedures described below are in accordance with the applicable requirements specified in Test Methods for Evaluating Solid Waste Physical/Chemical Methods, SW-846. Variations to this plan will be noted in the field record and in the final certification report.

3.4.1 Sampling Methodology

The verification sampling program is designed to demonstrate that waste material from the Basin F IRA Structures that has penetrated the liner system has been detected and removed, and that hazardous waste constituents in the soil below the units, if any, are below the risk-based levels identified in Section 3.4.2.

Verification sampling will be conducted in the excavation of the removed Ponds A and B, the Tank Farm, and beneath the sumps at the SQI. Samples will be collected from areas of visible staining, if any, once the liner systems have been removed and areas of visible staining will be excavated. In addition, samples will be collected from a grid system developed for the units and from below the sumps at SQI. Ponds A and B and the Tank Farm have been gridded into a number of "cells," each generally 150 feet square, as shown in Figures 3.4-1 and 3.4-2, respectively. Each of these cells is further divided into 50-foot subcells. One 50-foot subcell per 150-foot cell will be randomly selected at the time of sampling to be sampled as the verification for the overall 150-foot cell. For Ponds A and B, two samples will be collected from the cells in southernmost portion of the ponds (Figure 3.4-1). The sloping floor of these ponds results in a higher potential for leakage in the southern portions of the ponds surrounding

the sumps. One soil sample will be collected in a subcell from the top six inches of soil at the selected location.

Fifteen samples will be collected for Pond A, thirteen for Pond B, six for the Tank Farm, and 8 for the SQI. These samples were selected as a practical optimum to provide adequate monitoring of the closure process and verification of the cleanup attainment below the units. Should the samples for a particular cell not meet the clean closure criteria, the Army will evaluate further soil sampling and soil removal in the 150-foot cell.

3.4.2 Soil Verification Sampling Standards

Soil samples collected in the verification program will be used to demonstrate that clean closure has been achieved. The Part 265 clean closure performance standards for surface impoundments and tanks states that the owner/operator must remove or decontaminate contaminated soils contaminated with waste at the time of closure. The regulation state that only hazardous waste and hazardous waste residues must be removed from incinerators at closure. Regulatory guidance indicates that a clean closure demonstration for surface impoundments should document that contaminants left in the subsoils will not impact environmental media in excess of regulatory agency-recommended limits or factors, and that direct contact through dermal exposure, inhalation, or ingestion will not result in a threat to human health and the environment (52 Federal Register 8704).

The levels shown in Table 3.4-1 will be used to demonstrate clean closure of the Basin F IRA structures. These values will not be used as cleanup levels for historic contamination, but only as indicators that clean closure of the units has been achieved. By meeting these levels in soil beneath Ponds A and B, the Tank Farm, and the SQI sumps, the Army will have demonstrated that closure activities meet the clean closure standard.

The soil verification sampling standards are based on risk-based criteria established in the Final On-Post Integrated Exposure Assessment/Risk Characterization (IEA/RC) (Enserch 1994) and the Draft Final On-Post Detailed Analysis of Alternatives (DAA) (Ebasco 1993). The IEA/RC

calculated preliminary pollutant limit values (PPLVs) for lifetime excess cancer risks, lifetime noncarcinogenic exposure, and acute exposures for several scenarios. The evaluation criteria and remediation goals in the DAA are based on these PPLVs. In addition, the DAA considers concentration ranges associated with naturally occurring compounds. For inorganic compounds, indicator ranges were established in the Remedial Investigation to reflect the expected natural range for alluvial soils that have been impacted by contamination.

The soil verification sampling standards represent the lowest PPLV for a given contaminant considering a 10^{-6} excess cancer risk, noncarcinogenic exposure index of 1, and acute exposure of 1. In addition, the verification standards for inorganic compounds are adjusted for naturally occurring concentrations based on the indicator ranges.

The soil verification sampling standards listed in Table 3.4-1 also take into account ecological protection criteria developed in the IEA/RC. The levels represent a hazard quotient of one for medium-bodied burrowing animals. Burrowing animals were chosen because the biota soil criteria developed for other species in the IEA/RC were for 0- to 1-ft depth only, and the clean closure activities entail the removal of contaminated soils and recontouring below grade. In developing the ecological protection criteria, concentrations were averaged over a range, and the 0- to 1-foot depth concentrations were given a weight of 99.8 percent, compared to 0.2 percent for the 1- to 20-foot depth. Therefore, medium-bodied burrowing animal levels are the most accurate levels that can be used for clean closure activities, but are based on conservative exposure assumptions.

3.4.3 Sample Collection

Soil samples will be collected using an auger, a scoop, or a shovel. Procedures for collecting samples using the above mentioned equipment will be in accordance with SW-846. Samples will be placed in 6-inch stainless steel liners. Each stainless steel liner sent for analysis will be capped with Teflon film and plastic end caps, labeled, wrapped in saran wrap, sealed inside a plastic bag, and kept refrigerated at or below 4 degrees centigrade (C). Sampling equipment will be decontaminated prior to and between sampling events or locations.

3.4.4 Field Sampling QA/QC

Appropriate QA/QC procedures will be implemented to ensure that the samples collected are representative. This program is designed to ensure the reliability and validity of field and analytical laboratory data gathered as part of the overall sampling program. This program is to be exercised in both the field and the laboratory.

A routine collection of two types of Quality Control (QC) blanks, trip blanks and equipment blanks, will be performed during each sampling event. Trip blanks are used to determine if contamination is introduced from the sample containers and equipment blanks are used to determine if contamination is introduced by the sample collection equipment.

3.4.5 Analytical Procedures

PMRMA will use a laboratory that is inspected and determined to be adequate by the CDPHE. The laboratory will perform the analyses in accordance with approved procedures using trained personnel, calibrated equipment, and appropriate QA/QC procedures. The laboratory will use PMRMA and EPA/CDPHE approved test methods as specified in the following documents:

- Test Methods for Evaluating Solid Waste, SW-846, United States Environmental Protection Agency, 1986.
- Methods for Chemical Analysis of Water and Wastes, EPA-625/6-74-003a, 1974.
- Methods for Chemical Analysis of Water and Wastes, EPA-600/4-79-020, March 1979.

3.4.6 Chain-of-Custody Procedures

A chain-of-custody program will be implemented to trace the possession and handling of individual samples from the time of sample collection through laboratory analysis. Verifiable sample custody is an integral part of this Closure Plan. Several steps will be taken in the field and laboratory to document and ensure that samples collected in the field have been properly acquired, preserved, and identified.

3.5 RUNON AND RUNOFF CONTROL

During clean closure of the Ponds, the Tank Farm, and the SQI, the units will be dismantled and the excavation will be backfilled with clean material and compacted to the natural grade. Runon and runoff control structures for precipitation are, therefore, not necessary. Appropriate best management practices will be implemented per the storm water management plan for the applicable phases of site closure.

3.6 GROUNDWATER MONITORING

The upgradient and downgradient groundwater conditions will be monitored during the closure of the Structures. The Basin F Quarterly Monitoring Program will be used to assess the impact of the Structures on the groundwater in accordance with the requirements of 6 CCR 1007-3 part 265, subpart F. Additional downgradient wells may be required. Groundwater samples will be collected according to the procedures set forth in the Basin F Quarterly Groundwater Monitoring Sampling Plan.

3.7 SITE SECURITY

The following security measures will be in effect during closure of the Structures:

- Twenty-four-hour surveillance by facility personnel will control and monitor entry onto the formerly active portion of the site.
- A chain-link perimeter fence will prevent unknowing or unauthorized entry onto the formerly active portion of the facility. The fence will be the last element of the site security system to be removed.
- Access to the site during decontamination and demolition will be controlled at all times by facility personnel.
- Signage at each entrance and at other locations on the perimeter fencing, with the words "Danger-Unauthorized Personnel Keep Out" in English and Spanish, will be retained until the facility foundations are demolished, the soil is tested for contamination, and the fencing is removed.

3.8 SAFETY AND HEALTH PLAN

A Safety and Health Plan for the work being performed during the decommissioning and closure activities will be prepared before work begins. The purpose of the Safety and Health Plan is to assign responsibilities, establish protection standards, specify safe operating procedures, and provide for contingencies that may arise during the proposed site activities. The Safety and Health Plan will be explained to everyone participating in the field activities. The Safety and Health Plan will be evaluated throughout the course of the field activities to incorporate any changes to either the scope of work or technical information generated as a results of site activities.

3.9 DECONTAMINATION

All equipment and materials used in the decommissioning and closure activities will be decontaminated or properly disposed. Contaminated equipment will be brought to a decontamination area and cleaned with steam or high-pressure washing equipment. A visual inspection will be made to ensure that all visible contamination has been removed before the equipment or material is allowed to leave the pad. Personal decontamination and support facilities will be provided and located in accordance with the Safety and Health Plan. PPE will be decontaminated or managed as hazardous waste. Washwater from the decontamination will be collected and managed appropriately.

3.10 SPILL PREVENTION AND RESPONSE

During transfer of waste materials to and from the treatment, storage, or disposal units, and to trucks or railcars for on-site or off-site transportation, care will be taken to prevent and minimize spills. Trucks used in the transfer process will be loaded in an area constructed to contain spills. Any spill will be immediately vacuumed into tanks or trucks and/or contained with soil or nonreacting sorbent. Contaminated soil or material from any spill will be completely removed and placed in an appropriate storage or disposal unit.

3.11 COST ESTIMATE AND FINANCIAL ASSURANCE

According to 6 CCR 1007-3, Section 266.12(a), the owner/operator of a facility must have a detailed written estimate of the cost of closing the facility. Section 266.10(c), however, states that the State of Colorado and the federal government are exempt from the provisions of Part 266. Consequently, a cost estimate and evidence of financial assurance are not included in this Closure Plan.

3.12 SURVEY PLAT

Section 265.116 of 6 CCR 1007-3 requires the owner or operator to submit to CDH and the local zoning authority, or authority with jurisdiction over local land use, a survey plat indicating the location and dimensions of landfill cells or other hazardous waste disposal units with respect to survey benchmarks. Because the Structures were used as a temporary storage and treatment units, and not hazardous waste disposal units, the requirement does not apply.

3.13 TRANSPORTATION

Hazardous waste materials will be shipped offsite for treatment or disposal at a RCRA-permitted hazardous waste treatment or disposal facility during closure of the Structures. Trucks transporting the material will be inspected before leaving the site. Each offsite shipment will meet the DOT requirements for shipment of hazardous materials found in 48 Code of Federal Regulations (CFR) Part 172. Each shipment will be accompanied by a completed hazardous waste manifest that meets the requirements of 6 CCR 1007-3, Parts 262 and 263.

**TABLE 3.1-1
ESTIMATED VOLUME OF TANKS RESIDUE**

Tank	Temperature (degrees Fahrenheit)	Height of Hatch (feet)	Depth to Residue (feet)	Thickness of Residue (feet)	Estimated Volume of Residue (cy)
Tank 101	63	42.6	40.6	2.0	360
Tank 102	62	43.1	40.5	1.0	180*
Tank 103	64	41.8	40.7	1.1	<u>200</u>
Total					740

cy Cubic yard

- * Residue from Tank 102 has been removed as part of the Tank 102 Pilot-Scale Decontamination project. 150 cubic yards of residue were encountered during decontamination of Tank 102

TABLE 3.2-1
SQI EQUIPMENT REQUIRING INTERNAL
DECONTAMINATION PROCEDURES

Equipment	Description
Tanks	
TK-104	Wastewater Tank; elevated vertical tank, formerly contained wastewater; 30,000-gallon capacity; carbon steel; HDPE lining; insulation and metal jacket around outside
TK-105	Day Tank; elevated vertical tank; formerly contained diluted Basin F liquid; 14,000-gallon capacity; carbon steel; HDPE lining; insulation and metal jacket around outside
TK-106	Day Tank; elevated vertical tank; formerly contained diluted Basin F liquid; 14,000-gallon capacity; carbon steel; HDPE lining; insulation and metal jacket around outside
TK-201	Brine Holding Tank; elevated vertical tank; formerly contained brine; 41,000-gallon capacity; carbon steel; plasite lining
TK-202	Brine Holding Tank; elevated vertical tank; formerly contained brine; 41,000-gallon capacity; carbon steel; plasite lining
TK-204	50 percent Caustic Storage Tank; elevated vertical tank; formerly contained 50 percent caustic solution; 35,000-gallon capacity; carbon steel; insulation and metal jacket around outside
TK-205	Twenty percent Caustic Dilution Tank; elevated vertical tank; formerly contained 20 percent caustic solution; 7500-gallon capacity; carbon steel; insulation and metal jacket around outside
Sumps	
TK-109	Flush Water Drain Sump; 4'5"x7'6" Height; 700-gallon capacity; HDPE lined; carbon steel with cover
TK-110	Drain Sump; 3'x3'x3' deep; 200-gallon capacity; reinforced vinyl ester-lined concrete
TK-401A	SQI Evaporator Area
TK-401B	Process Water Tank Area Sump; 30"x30"x18" deep; 45-gallon capacity; epoxy-coated concrete
TK-402 A/B/C	Brine/Caustic Storage Sump; 30"x30"x12" deep; 45-gallon capacity; epoxy-coated concrete
TK-403	SQI Process Area Sump; 30"x30"x18" deep; 45-gallon capacity; epoxy-coated concrete
TK-404	Day Tank Area Sump; 30"x30"x18" deep; 45-gallon capacity; epoxy-coated concrete
TK-405	Utility Room Sump; 30"x30"x18" deep; 45-gallon capacity; epoxy-coated concrete
TK-406	Maintenance Area Sump; 30"x30"x18" deep; 45-gallon capacity; epoxy-coated concrete
TK-407	SQI Washdown & Maintenance Area Sump; 30"x30"x18"; 45-gallon capacity; epoxy-coated concrete

TABLE 3.2-1
SQI EQUIPMENT REQUIRING INTERNAL
DECONTAMINATION PROCEDURES

Equipment	Description
Mixers	
M-101	Wastewater Tank Mixer; dual impeller; FRP; installed on TK-104
M-102	Day Tank Mixer; dual impeller; FRP; installed on TK-105
M-103	Day Tank Mixer; dual impeller; FRP; installed on TK-106
M-201	Caustic Tank Mixer; single impeller; stainless steel; installed on TK-204
M-202	Dilution Tank Mixer; installed on TK-105
M-204	Brine Tank Mixer; side entering; installed on TK-201; alloy 20
M-205	Brine Tank Mixer; side entering; installed on TK-202; alloy 20
Heaters	
E-203	Heater; U-Tube Bayonet; 35 SF; 316 SS; installed on TK-204
SQI Equipment	
IN-201	Incinerator
S-201	Separator and Sump
S-202	Venturi and Sump
T-201	Scrubber Tower
Stack	
S-202	Vortex Separator
Pumps	
P-101 A/B	Two pumps; service for Basin F fluid; horizontal centrifugal pump; 40-gpm capacity
P-103 A/B	Two pumps; service for Basin F fluid; horizontal centrifugal pump; 40-gpm capacity
P-104 A/B	Two pumps; service for Basin F fluid; horizontal centrifugal pump; 10-gpm capacity
P-106	Service for wastewater; vertical cantilevered pump; 60-gpm capacity
P-107	Service for Basin F fluid; horizontal centrifugal pump; 150-gpm capacity
P-201 A/B	Two pumps; service for Basin F fluid; 85-gpm capacity
P-202 A/B	Two pumps; service for quench recycle; 145-gpm capacity
P-203 A/B/C	Two pumps; service for scrubber recycle; 660-gpm capacity
P-205 A/B	Quench Tank Recirculation pumps; 350-gpm capacity
P-206 A/B	Two pumps; service for brine; horizontal centrifugal pump; 300-gpm capacity; coated steel
P-208 A/B	Two pumps; service for 20 percent caustic solution; pump; 45-gpm capacity
P-210 A/B	Two pumps; service for 50 percent caustic solution; horizontal centrifugal pump; 200-gpm capacity

TABLE 3.2-1
SQI EQUIPMENT REQUIRING INTERNAL
DECONTAMINATION PROCEDURES

Equipment	Description
P-211 A/B	Two pumps; service for 50 percent caustic solution; horizontal centrifugal pump; 8-gpm capacity
P-212	Nozzle Cleanout Water Feed Pump
P-401 A/B	Two pumps; service for truck decontamination/caustic sump transfer pump; installed on TK-401; air diaphragm pump; 25-gpm capacity
P-402 A/B/C	Three pumps; service for brine/caustic area sump transfer pump; installed on TK-402; air diaphragm pump; 25-gpm capacity
P-403	Service for SQI process sump transfer pump; installed on TK-403; air diaphragm pump; 50-gpm capacity
P-404	Service for day tank sump transfer pump installed on TK-404; air diaphragm pump; 5-gpm capacity
P-405	Service for utility room sump transfer pump; installed on TK-405; air diaphragm pump; 5-gpm capacity
P-406	Service for maintenance area sump transfer pump; installed on TK-406; air diaphragm pump; 10-gpm capacity
P-407	Service for boot wash sump transfer pump; installed on TK-407; air diaphragm pump
P-408	Service for wastewater; vertical cantilevered pump; 50-gpm capacity
P-409	Sump Pump; vertical centrifugal; 8-gpm capacity; Kynar; installed on TK-409

FRP Fiberglass reinforced plastic
 gpm Gallons per minute
 HDPE High-density polyethylene
 SQI Submerged quench incinerator

TABLE 3.2-2
SQI EQUIPMENT REQUIRING EXTERNAL-RINSE
DECONTAMINATION PROCEDURES

Equipment	Description
Utility Equipment	
H-201	Water heater
V-401	Air receiver tank; 500-gallon capacity
V-403	Water softener
BL-401	Steam boiler; 5000 pounds per hour
DR-401	Air dryer
HP-104	Electric pad heater
HP-105 & 106	Electric pad heater
HP-203 & 204	Electric pad heater
SG-401	Steam generator
WS-401	Boiler water treatment
F-401A/B	Coalescing filter
F-402A/B	Intake filter/silencer
F-403	Particulate filter

**TABLE 3.2-3
SQI EQUIPMENT REQUIRING
NO DECONTAMINATION PROCEDURES**

Equipment	Description
Tanks	
TK-107	Purge Water Tank; elevated vertical tank; formerly contained water; 3000-gallon capacity; carbon steel; insulation and metal jacket around outside (Pumphouse No. 1)
TK-108	Purge Water Tank; elevated vertical tank; formerly contained water; 3000-gallon capacity; carbon steel; insulation and metal jacket around outside (Pumphouse No. 2)
TK-203	Dilution Water Storage Tank; elevated vertical tank; formerly contained process water; 9930-gallon capacity; carbon steel; insulation and metal jacket around outside
TK-206	Diaphragm Tank; 320-gallon capacity
TK-410	Brine Water Tank
TK-411	Chemical Treatment Tank
TK-412	Feedwater Supply Tank
TK-413	Blowdown Separator Tank
Mixers	
M-401	Chemical Treatment Tank Mixer; single propeller; installed on TK-411
Heaters	
IH-101 A,B	Tank Heater; electric bayonet; copper heater elements; installed on TK-107 (Pumphouse No. 1)
IH-102 A,B	Tank Heater; electric bayonet; copper heater elements; installed on TK-108 (Pumphouse No. 2)
Pumps	
P-102	Service for water; vertical in-line centrifugal pump; 55-gpm capacity
P-105	Service for water; vertical in-line centrifugal pump; 55-gpm capacity
P-207 A/B	Two pumps; service for treated water
P-209 A/B	Two pumps; service for process water; horizontal centrifugal pump; 18-gpm capacity
P-411	Service for chemical feed; positive displacement pump
P-412 A/B	Two pumps; service for boiler water; centrifugal pump; 10-gpm capacity
P-413	Service for chemicals; hand drum pump
P-414	Service for chemicals; hand drum pump
Blowers	
B-201 A/B	Combustion Air Blower
Compressors	
C-201 A	Atomizing Air Compressor
C-401 A/B	Air Compressors; rotary screw

gpm Gallons per minute

**TABLE 3.3-1
WASTE GENERATION SUMMARY FOR POND A & B CLOSURE**

Waste Types/Description	Estimated Volume/Area/Length	Estimated Weight
Foundations/Slabs		
Concrete Post Bases	230 cubic yards	263 tons
Pumphouse #1 Slab	71 cubic yards	83 tons
RFP Piping (Ponds to Pumphouse #1)	2000 linear feet	--
HDPE Materials (liners, geonets)		
Liners (2)	630,000 square feet	95 tons
Geonet	315,000 square feet	26 tons
Sump and Piping	1 cubic yard	1 ton
Hypalon Cover	134,000 square feet	28 tons
Facility Fencing		
Chain Link	2600 linear feet	--
Fence posts	260 posts	
Miscellaneous Structures/Appurtenances	1 unit	3 tons
FRP Pipeline (Pumphouse #1 to Tanks)	1560 linear feet	--
Pipeline Posts	624 linear feet	--
Pumphouse #1		
Steel/Siding & Frame	--	6.8 tons
Insulation	2840 square feet	--
Purgewater Tank	1 unit	--
Pumps	4 units	--
Contaminated Soils	1000 cubic yards	1500 tons
Sediment/Solids	245 cubic yards	347 tons
Activated Carbon	--	2 tons
Personal Protective Equipment	95 drums	9.5 tons
Residue Dissolution Liquids	1,400,000 gallons	--
Decontamination Rinse water	191,000 gallons	--

HDPE: High-density polyethylene

**TABLE 3.3-2
WASTE GENERATION SUMMARY FOR TANK FARM CLOSURE**

Waste Types/Description	Estimated Volume/Area/Length	Estimated Weight
Foundations/Slabs		
Tank concrete foundation	138 cubic yards	372 tons
Concrete post bases	85 cubic yards	100 tons
Pumphouse #2 Slab	77 cubic yards	89 tons
Tank Shells/Aluminum Roofs		
Steel tank shells	100 cubic yards	--
Roof aluminum	500 cubic yards	--
Roof supports	--	3000 pounds
Process and Utility Piping		
Steel pipe	800 linear feet	--
Valves	--	1000 pounds
Overflow pipe assembly	--	500 pounds
liquid level gauge	--	500 pounds
FRP pipeline	1090 linear feet	3900 pounds
HDPE Materials (liners, geonets)		
HDPE liner	77,280 square feet	12 tons
Geonet	19,720 square feet	2 tons
Facility Fencing		
Chain link	1680 linear feet	--
Fence posts	168 units	--
Miscellaneous		
Structures/Appurtenances		
Roof gaskets	--	100 pounds
Heat trace cable	500 linear feet	--
Pipeline posts	252 linear feet	--
Pumphouse #2		
Siding and frame	--	7 tons
Insulation	2870 square feet	--
Purge water tank	1 unit	--
Pumps	3 units	--
Contaminated Soils	6900 cubic yards	9800 tons
Activated Carbon	--	12.5 tons
Personal Protective Equipment	25 drums	2.5 tons
Residue Dissolution Liquids	323,000 gallons	
Decontamination Rinse water		
Rinse water	15,000 gallons	
Scrubber blowdown	29,000 gallons	

HDPE: High-density polyethylene

* Volumes of dissolution liquids and rinse water do not include current liquid wastes generated as part of Tank 102 Pilot Decontamination study

**TABLE 3.3-3
WASTE GENERATION SUMMARY FOR SQI CLOSURE**

Waste Types/Description	Estimated Volume/Area/Length	Estimated Weight
Foundations/Slabs		
Concrete slabs contaminated	90 cubic yards	90 tons
Concrete slabs	1,100 cubic yards	1400 tons
Asphalt roads	1,160 cubic yards	--
Decontaminated Equipment/Components		
Vessels	5 units	121 tons
Compressors and blowers	7 units	12 tons
Pumps	42 units	5 tons
Mixers	7 units	3 tons
Special items	18 units	18 tons
Instrumentation/Controls		
Continuous emission monitoring	1 unit	--
Primary control panel	1 unit	--
Secondary control panel	1 unit	--
Valves, actuators, transmitters	770 items	--
Tank Shells/Roofs	--	30 tons
Building Shells/Structural Steel	--	335 tons
Process and Utility Piping		
Process piping	170 linear feet	2,000 pounds
Utility piping	2,970 linear feet	16,600 pounds
Plastic Piping		
FRP piping	1,625 linear feet	3500 pounds
PVC piping	410 linear feet	500 pounds
HDPE Materials (liners)	2,300 square feet	--
Facility fencing		
Chain link	3,800 linear feet	--
Fence posts	400 posts	--
Miscellaneous Structures/Appurtenances		
Building Insulation	1,150 cubic yards	--
Wood	55 cubic yards	--
Gypsum	44 cubic yards	--
Refractory Liner/Slag	270 drums	70 tons
Contaminated Soils	25 cubic yards	36 tons
Sediment/Soils	8 cubic yards	12 tons
Activated Carbon	--	12.5 tons
Personal Protective Equipment	44 drums	4.4 tons
Final Decontamination	75,000 gallons	--

FRP: Fiberglass reinforced plastic
HDPE: High-density polyethylene

**TABLE 3.3-4
BASIN F IRA STRUCTURES WASTE STREAM
DISPOSAL/TREATMENT MATRIX**

Waste Types	Off Post Hazardous Waste Landfill	Salvage/ Reuse	Treatment at SQI	Off-Post Incineration/ Hazardous Waste Landfill	Off-Post Incineration/ Disposal
Foundation/Slabs	X	X ¹			
Decontaminated equipment/components		X			
Instrumentation/controls		X			
Tank shells/aluminum roofs		X			
Building shells/structural steel		X			
Process and utility piping	X	X			
Plastic piping	X				
HDPE materials (liners, geonets)	X				
Facility fencing		X			
Miscellaneous structures/appurtenances	X	X			
Refractory liner/slag	X				
Contaminated soils				X	
Sediment/solids				X	
Activated carbon		X			
Personal protective equipment	X				
Residue dissolution liquids			X		
Decontamination rinsewater			X		

HDPE: High-density polyethylene

¹ Concrete/asphalt not potentially contaminated will be salvaged/reused.

TABLE 3.4-1
SOILS VERIFICATION STANDARDS

Chemical/Contaminant	Proposed Soil Standards (ppm)—Human Health ¹	Proposed Soil Standards (ppm)—Biota ²	Proposed Clean Closure Standard (ppm)
Aldrin	0.72	.47	.47
Benzene	10		10
Carbon Tetrachloride	2.3		2.3
Chlordane	3.7		3.7
Chloroacetic Acid	77		77
Chlorobenzene	850		850
Chloroform	48		48
DDE	13	.44	.44
DDT	14	.44	.44
DBCP	0.24		.24
1,2-Dichloroethane	3.2		3.2
1,1-Dichloroethylene	0.52		.52
Dicyclopentadiene	3,700		3,700
Dieldrin	0.41	.47	.41
Endrin	56	.5	.5
Hexachlorocyclopentadiene	1,100		1,100
Isodrin	52		52
Methylene Chloride	44		44
1,1,2,2-Tetrachloroethane	1.5		1.5
Tetrachloroethylene	5.9		5.9
Toluene	5,600		5,600
Trichloroethylene	28		28
Arsenic	14		14
Cadmium	52		52
Chromium	48		48
Lead	2,200		2,200
Mercury	570	.14	.14

Notes:

¹ Clean closure standards based on PPLVs for 10⁻⁶ excess lifetime cancer risk, hazard index of 1.0 for noncarcinogenic exposure and hazard index of 1 for acute index from Final On-Post Integrated Endangerment Assessment/Risk Characterization.

² Based on an HQ of 1 for medium mammals (Ebasco 1994).

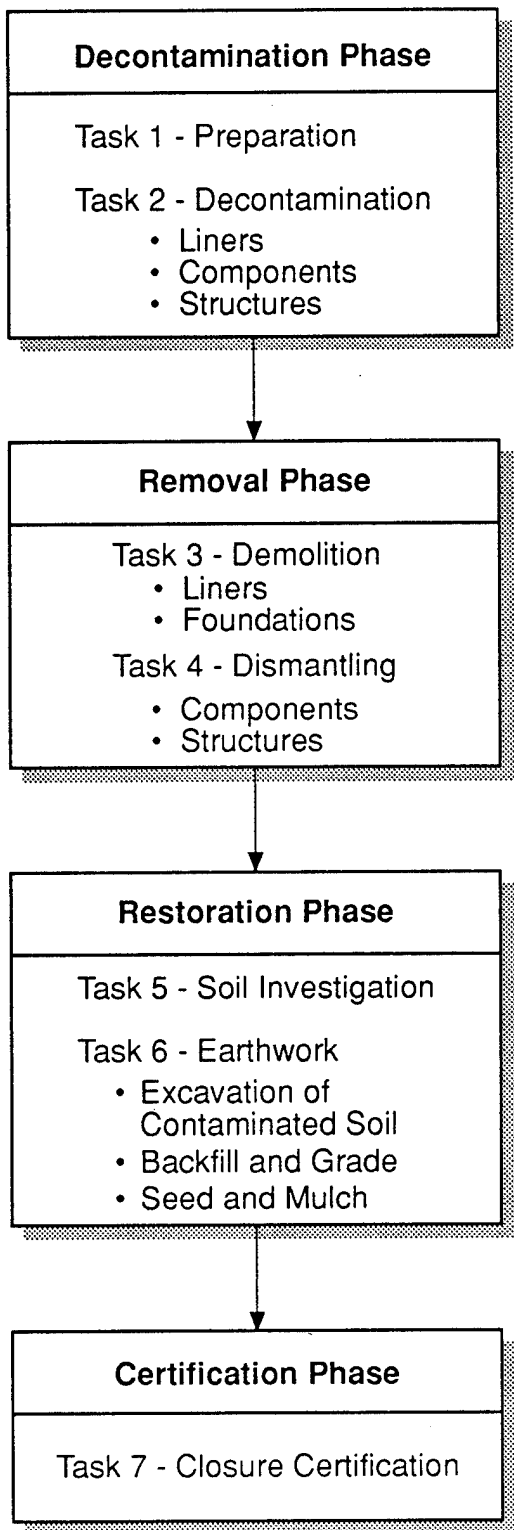

Prepared for:
Program Manager for
Rocky Mountain Arsenal
Commerce City, Colorado
Prepared by:
RUST TERC 1 Team

Figure 3.2-1
Standardized Closure Process

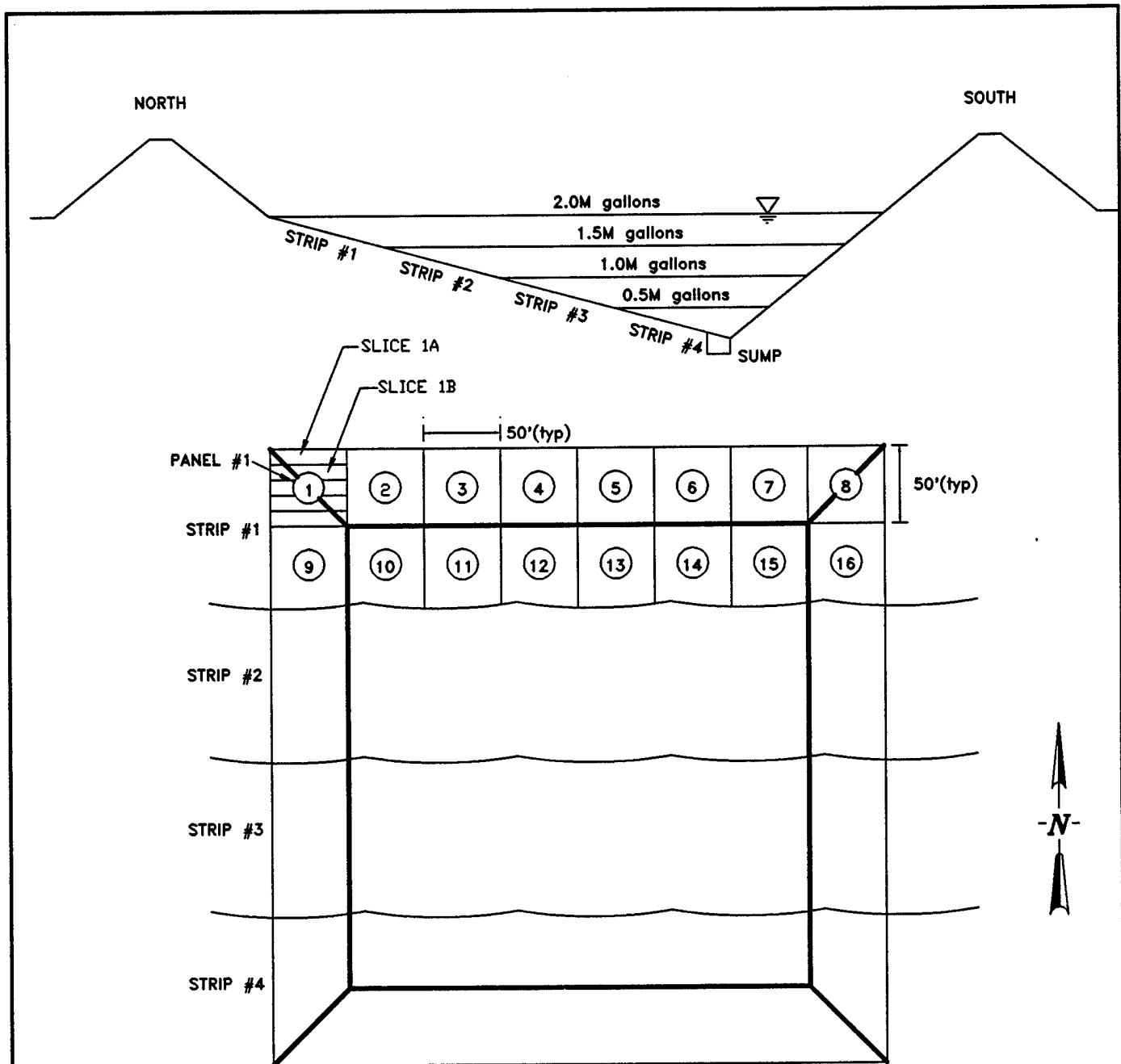

STRIP/PANEL LAYOUT

Prepared for:

Program Manager for
Rocky Mountain Arsenal
Commerce City, Colorado

Prepared by:

RUST TERC 1 Team

Figure 3.2-2

POND COVER/LINER REMOVAL DIAGRAM
BASIN F: POND A/B CLOSURE

①

FILE NAME 55051\CORP\F01-001.DWG REVISION NO. 0
DATE 9/8/94
DRAWN BY EMH
APPROVED BY
CHECKED BY

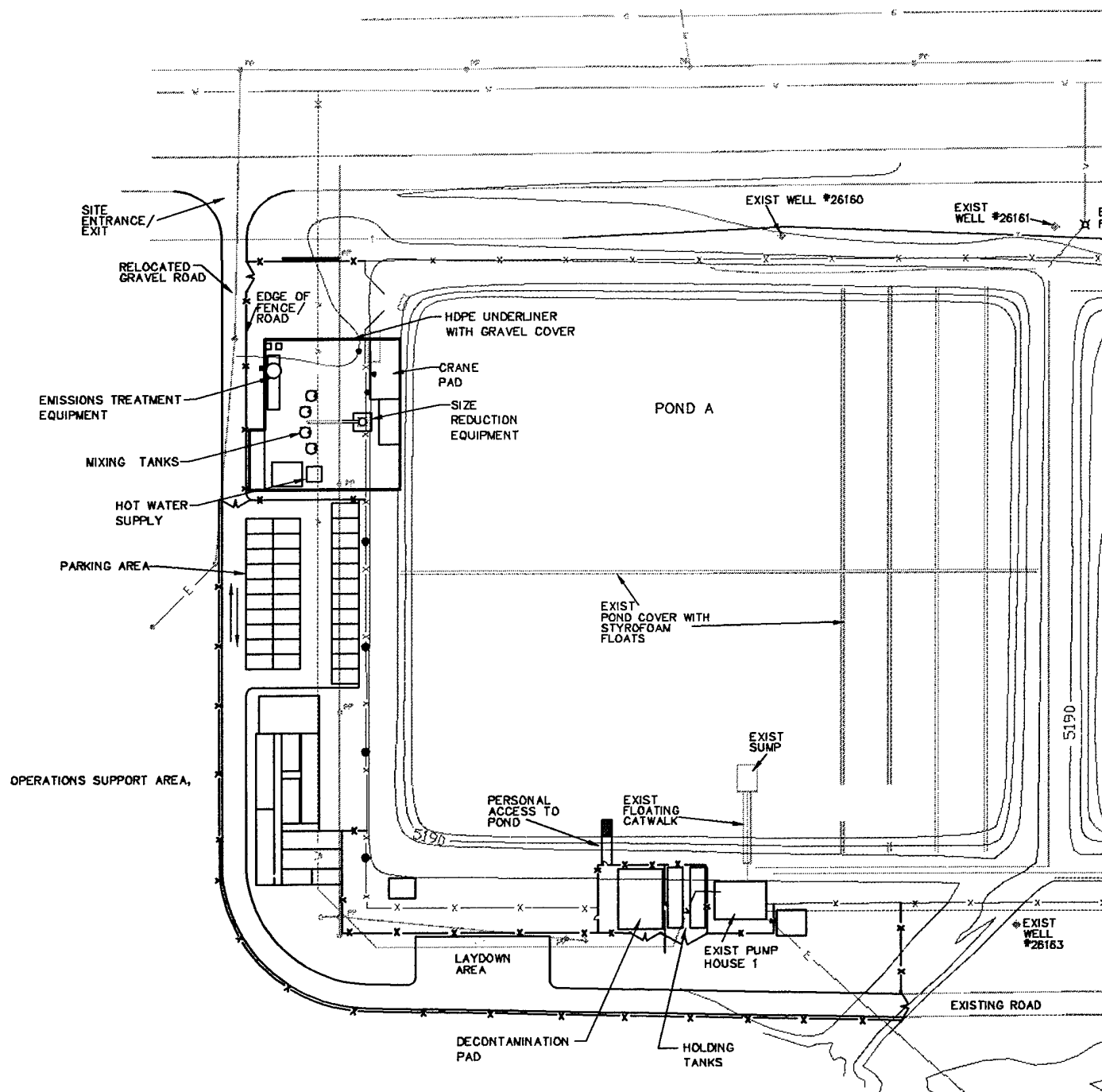

NOTE: LOCATIONS IDENTIFIED ARE CONCEPTUAL AND MAY BE MODIFIED DURING SITE PREPARATION

2

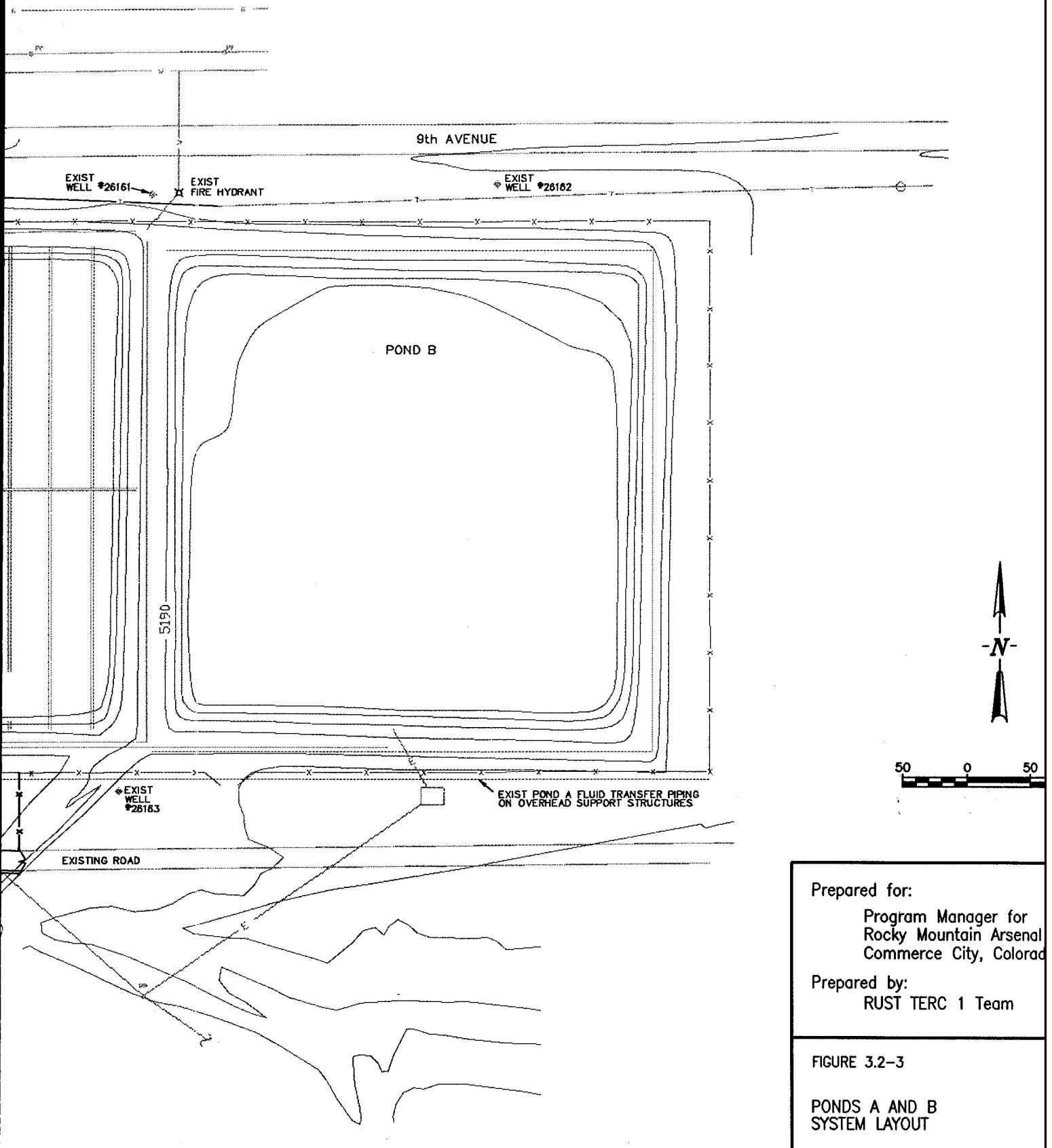

Prepared for:
Program Manager for
Rocky Mountain Arsenal
Commerce City, Colorado

Prepared by:
RUST TERC 1 Team

FIGURE 3.2-3

PONDS A AND B
SYSTEM LAYOUT

2

3

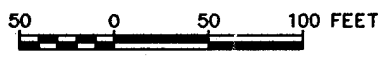
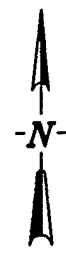
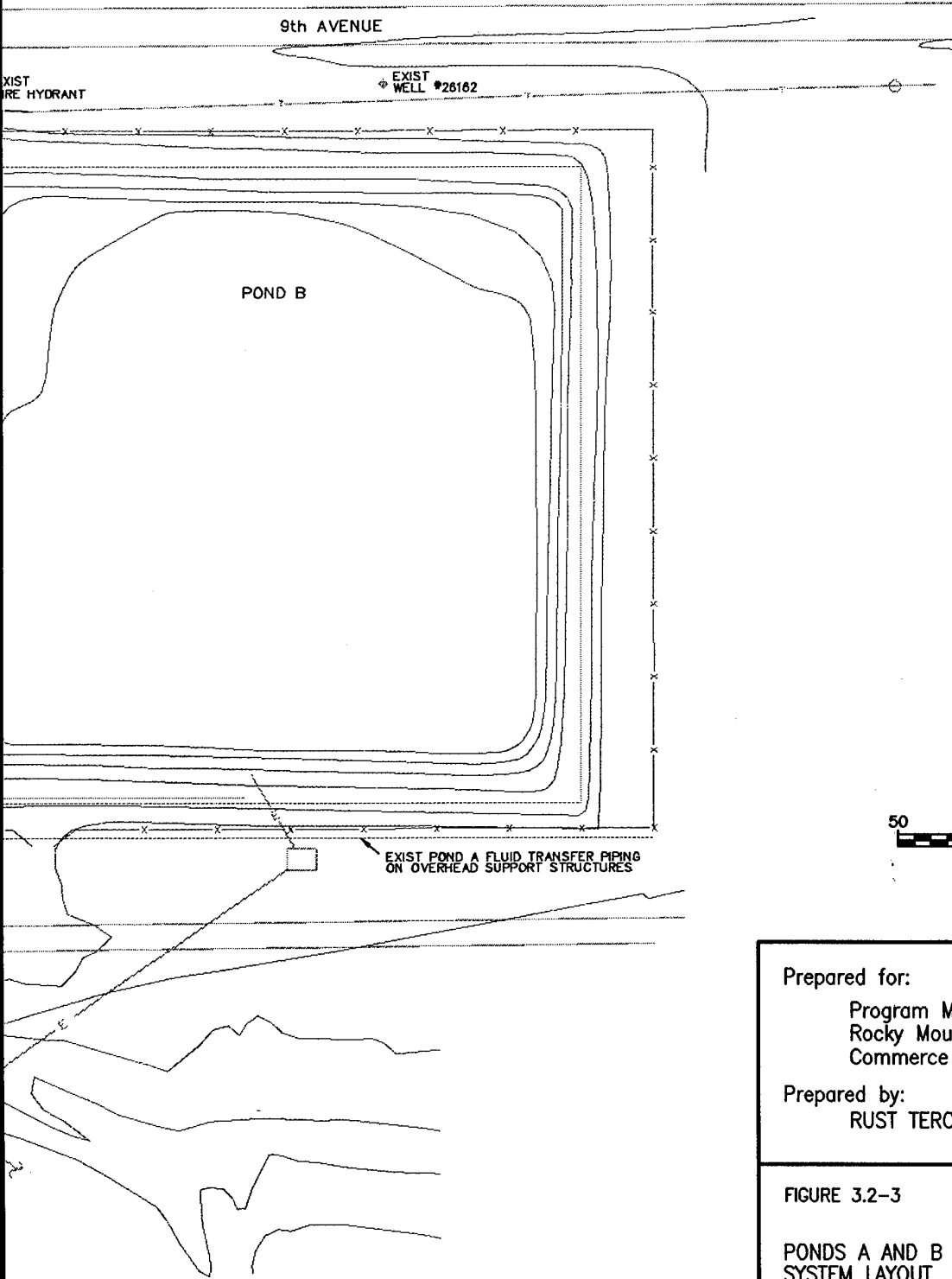

Prepared for:
Program Manager for
Rocky Mountain Arsenal
Commerce City, Colorado

Prepared by:
RUST TERC 1 Team

FIGURE 3.2-3
POND A AND B
SYSTEM LAYOUT

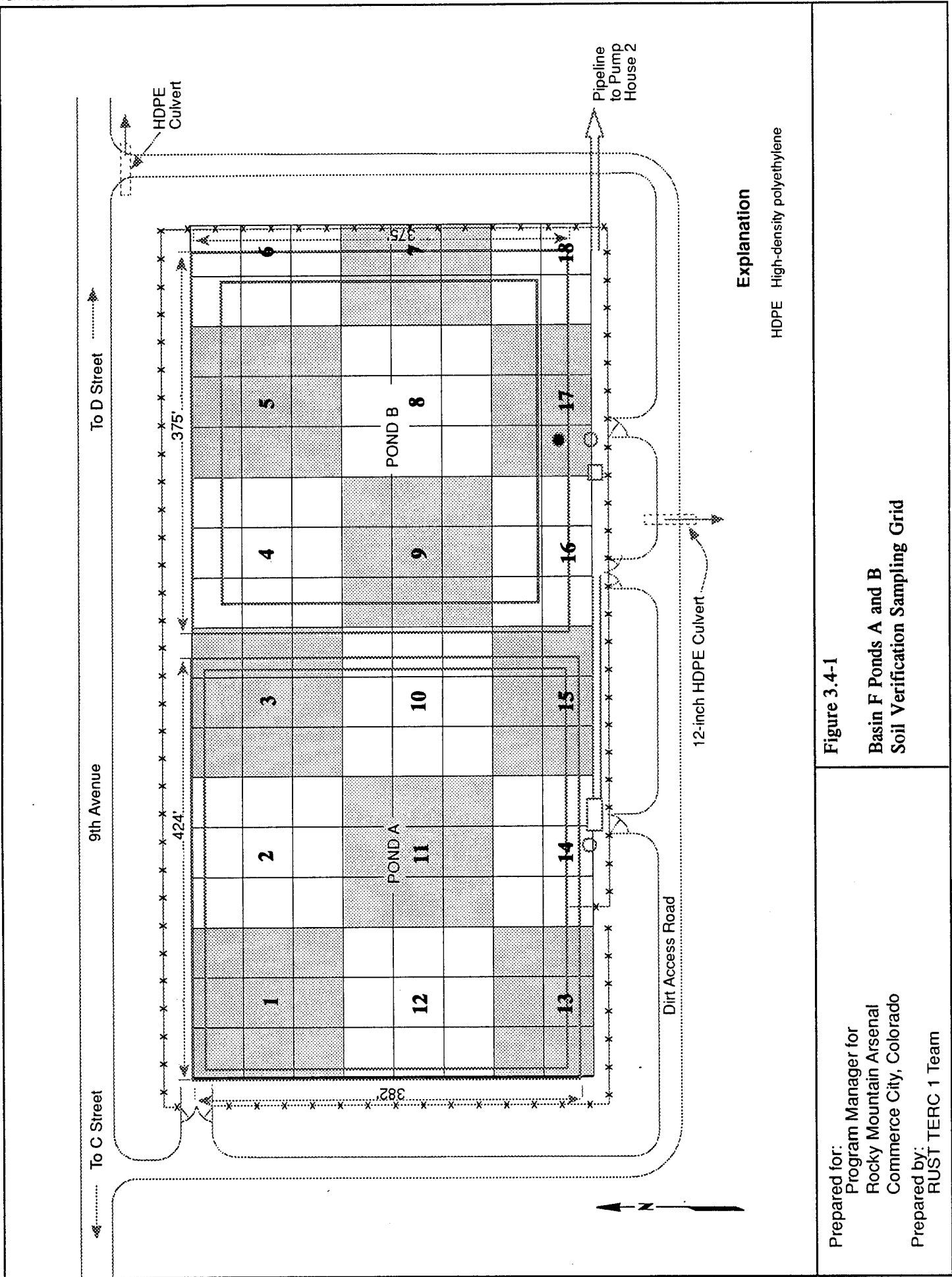

Explanation

HDPE High-density polyethylene

Figure 3.4-1
Basin F Ponds A and B
Soil Verification Sampling Grid

Prepared for:
 Program Manager for
 Rocky Mountain Arsenal
 Commerce City, Colorado
 Prepared by:
 RUST TERC 1 Team

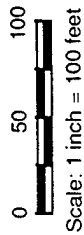
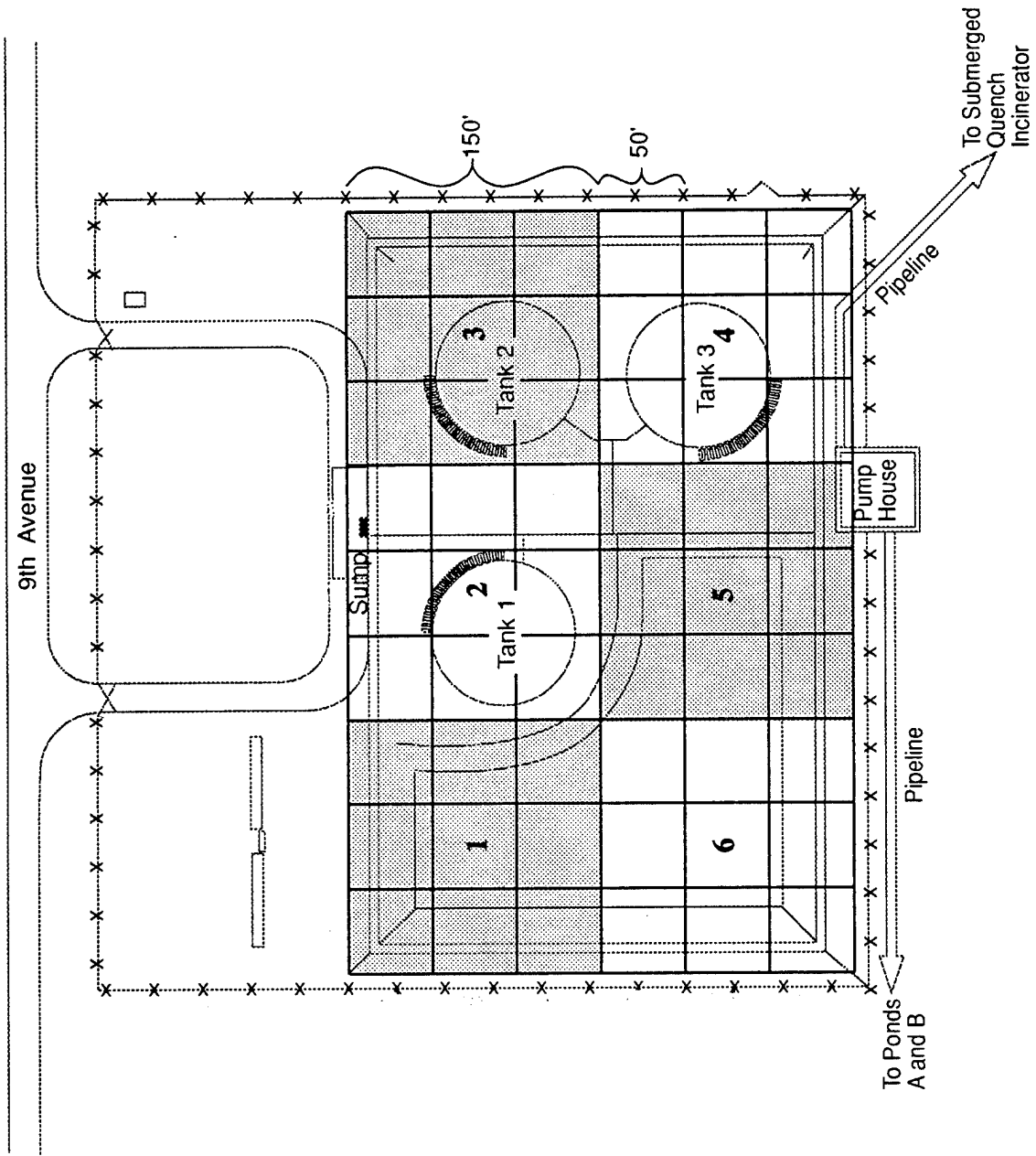

Figure 3.4-2
Basin F Tank Farm Plan
Soil Verification Sampling Grid

Prepared for:
Program Manager for
Rocky Mountain Arsenal
Commerce City, Colorado

Prepared by:
RUSTERC 1 Team

4.0 CLOSURE SCHEDULE

4.1 EXPECTED YEAR OF CLOSURE

Closure of the Structures is estimated to begin once the Basin F liquid has been removed from Pond A and the Colorado Department of Health has approved the Closure Plan. This schedule is based on an actual SQI performance.

4.2 MILESTONE CHART

A detailed schedule of the Structures closure tasks is shown in Figure 4.2-1. The following sections detail the time requirements for each of the tasks.

4.2.1 Decontamination Phase

The removal, treatment, and disposal of liquid for Pond A is estimated to be completed in the first quarter of 1995. Equipment will be mobilized to the site prior to Pond A being empty and being released from operation. During this time, the contractor will have to finalize work plans, purchase special equipment, and arrange all subcontracts required to execute the project. Once mobilized with an administration area and equipment and personnel decontamination facilities, the contractor will begin the decontamination phase for Pond A. This task is expected to take up to 6 weeks, and the residue dissolution liquid will be pumped to the tanks. Pond B will not require decontamination as it was decommissioned in 1988.

Closure of the Tank Farm will begin once the tanks have been drained of Basin F liquid. The Army has performed a pilot decontamination project for the empty Tank 102 to evaluate residue dissolution and decontamination technology and to provide an additional measure of protectiveness to human health and the environment. The Tank 102 decontamination project included residue dissolution, liner decontamination, liner demolition activities, and tank wall decontamination. The residue dissolution liquid from this demonstration project was returned to Pond A. The Tank 102 shell will remain in place until closure of the Tank Farm facility. The shell and foundation were disturbed during the demonstration project so that the integrity

of the Tank Farm secondary containment structure shared by all tanks will not be compromised.

Closure of the Tank Farm will begin with the initiation of decontamination activities for either Tank 101 or Tank 103. Following the completion of these activities, decontamination activities will be initiated for the other tank. Each cycle of residue dissolution will take approximately 2 weeks to complete. In addition, the tank interior will be decontaminated by pressure washing following the removal of the liner and geonet, which will require approximately 2 weeks for each tank.

The SQI operation and maintenance staff will be responsible for decontamination phase execution because the decontamination procedures are no different than those used in SQI maintenance operations. Following the SQI process flow sequence, the operation and maintenance staff will isolate, rinse, and drain each item of process equipment. The equipment will then be further rinsed and inspected as part of closure activities to confirm the effectiveness of the decontamination through visual observations. Internal and external rinsing in the operating areas of the facility is expected to take six weeks.

4.2.2 Removal Phase

The Pond A and Pond B primary liners, geonets, and secondary liners will be decontaminated with a high-pressure, high-temperature spray wash and subsequently removed. It is estimated that these tasks will take 5 weeks. High-pressure and high-temperature spray washing will be used to appropriately decontaminate the leachate collection system at Pond A and Pond B and can be initiated after removal of the liner system. This task will take approximately three weeks to complete. High-pressure and high-temperature spray washing and steam cleaning will be used to appropriately decontaminate and dismantle the pumphouse number one, transfer piping, and ancillary equipment/structures and can be initiated after the liners have been removed. These tasks will take approximately three weeks to complete. The removal phase for Ponds A and B is estimated to entail 2 months.

Once the residues have been removed from Tanks 101 and 103, the internal tank liners and geonet strips will be removed. The activity will take approximately two weeks per tank. Following decontamination of the tanks walls, the tank shells, structures, and appurtenances will be dismantled. Tank 102 will also be dismantled. The dismantling of each tank will take approximately one month to complete. Following the completion of dismantling the superstructures from the Tank Farm, the remaining foundations, soil, and secondary containment liner systems will be demolished. This activity will take approximately six weeks to complete for the entire tank farm. The removal phase for the tanks is estimated to entail 5 months.

SQI piping and instrument fittings will be dismantled to free the main items of process equipment for removal from their structural supports. Process equipment and utility packages will be lifted clear of the structure and transported for reuse/salvage which is expected to take approximately 3 months to complete. The building insulation, roof, wall covering, and steel framework will then be removed using conventional dismantling techniques. This portion of the dismantling of the SQI is expected to take 6 weeks to complete.

4.2.3 Restoration Phase

Following the removal of Pond A, Pond B, and Tank Farm and the dismantling of the SQI, soil in the excavations will be analyzed in accordance with Section 3.4 of this Closure Plan. This task will take approximately two weeks to complete for Ponds A and B, two weeks for the Tank Farm, and 1 week for the SQI.

The schedule assumes that isolated areas of contaminated soils will be encountered below Ponds A and B which will require approximately 3 weeks for excavation. The removal of the soils above the secondary liner in the Tank Farm is included in the removal phase.

Based on the careful maintenance techniques employed at the SQI, and the recent construction of the SQI, the amount of contaminated soils identified should be minimal. Any contaminated soils would probably be associated with the sumps. The schedule assumes that up to two weeks would be required to remove any contaminated soils near the sumps.

Final grading and compaction of fill material to restore the site to a draining condition will be initiated after the removal of contaminated soil and will take approximately two months to complete for Pond A and Pond B. The Tank Farm and SQI will each take approximately 1 month.

4.2.4 Certification Phase

After the site has been backfilled and graded, the independent professional engineer will be allowed 60 days to complete the closure certification process.

4.3 TOTAL TIME TO CLOSE

As shown in Figure 4.2-.1, the total time for closure of the Structures is estimated to be 16 months. This duration does not include the certification phase.

4.4 REQUEST FOR EXTENSION TO DEADLINES

Because the closure process is expected to take longer than 180 days, an extension of the closure period will be necessary.

4.5 AMENDMENT OF CLOSURE PLAN

If the Closure Plan needs to be amended after it has been approved, it will be done in accordance with 6 CCR 1007-3 Section 265.112(c) by submitting a written request for authorization to CDH for changes to the Closure Plan along with a copy of the amended Closure Plan. The Army will amend the Closure Plan in the event of changes in the facility design or operation that affect the Closure Plan, an applicable change in the closure date, or unexpected circumstances during the closure activities, such as extensive soil contamination below the units.

5.0 CONTINGENCY CLOSURE PLAN

If the results from the soil investigation (Task 5) indicate that Pond A and Pond B cannot be clean closed, the Army will close the units in accordance with 6 CCR 1007-3, Section 265 228(a)(2). The Contingency Closure Plan will then require closure of the unit as a landfill. If it is necessary to close Pond A or B according to the Contingency Closure Plan, the Army will submit an amended closure plan for the unit within 30 days of the determination in accordance with 6 CCR 1007-3, Section 265.112(c)(3).

6.0 REFERENCES

- Ebasco Services, Inc. 1989. *Draft final water remedial investigation report, Rocky Mountain Arsenal, Commerce City, Colo.*, March.
- Ebasco Services, Inc. 1993a. *Draft detailed analysis of alternatives (DAA), Rocky Mountain Arsenal, Commerce City, Colo.*, July.
- Ebasco Services, Inc. 1993b. *Draft integrated endangered assessment/risk characterization (IEA/RC), Rocky Mountain Arsenal, Commerce City, Colo.*, August.
- Environmental Science and Engineering, Inc. 1987. *Final phase I contamination assessment report site 26-3: Basin C, Rocky Mountain Arsenal, Adams County, Colo.*, December.
- Environmental Science and Engineering, Inc. 1988a. *Final phase I contamination assessment report site 26-1: deep disposal well and chemical sewers, Rocky Mountain Arsenal, Adams County, Colo.*, March.
- Environmental Science and Engineering, Inc. 1988b. *Final phase I contamination assessment report site 26-6: Basin F, Rocky Mountain Arsenal, Adams County, Colo.*, May.
- Environmental Science and Engineering, Inc. 1988c. *Final phase II data addendum site 26-1: deep disposal well, Rocky Mountain Arsenal, Adams County, Colo.*, August.
- Harding Lawson Associates. 1992. *Groundwater monitoring program final annual groundwater monitoring report for 1991, Rocky Mountain Arsenal, Commerce City, Colo.*, September.
- Harding Lawson Associates. 1993. *Final work plan for the groundwater monitoring program; Prepared for Program Manager for Rocky Mountain Arsenal, RTIC #93*, March 11.
- May, J. 1982. *Regional Groundwater study of Rocky Mountain Arsenal, Denver, Colo., Technical Report G2-82-6*, July.
- Morrison-Knudsen Engineers, Inc. 1988. *Geology of the RMA, Adams County, Colo.*, January.
- Roy F. Weston, Inc. 1991. *Final response action plan for the Basin F interim response action surface impoundment: Pond A, Prepared for Program Manager for Rocky Mountain Arsenal*, February.
- Vispi, M. A. 1978. *Report of finding, Rocky Mountain Arsenal pumping tests; U.S. Army Engineer Waterways Experiment Station Corp of Engineers, Vicksburg, Miss., RTIC #81266R70*, September.

U.S. Environmental Protection Agency. 1991. Letter from Connaly E. Mears to Kevin Blose, PMRMA, November 12.

Woodward-Clyde Consultants. 1989. *Final treatment assessment report, Basin F liquid treatment design, Volume 1, Version 3.0*, December.

Woodward-Clyde Consultants. 1993. *Comprehensive air quality and meteorological monitoring program; contract no. DAAA15-90-D-0010, air quality data assessment report for FY92, Final, Prepared for Program Manager for Rocky Mountain Arsenal, RTIC #93333R04*, September.