

**Southwest Border
Communications Network**

**System Requirements
Document - BAA Version**

DISTRIBUTION STATEMENT A

**Approved for public release;
Distribution Unlimited**

DTIC QUALITY INSPECTED 2

November 2, 1995

C4I-C95-05-002 (v.baa)

U.S. Army White Sands Missile Range - Electronic Proving Ground
Support to the Local and Federal Law Enforcement Agencies

19960126 049

CONTENTS

Executive Summary	iii
Law Enforcement Requirements	iii
Network Design	iii
Network Implementation	iv
Introduction	1
Current Interagency Communications	3
Requirements Overview	4
Recommended Approach	5
Reference	7
Abbreviations	7
Appendixes	
A. Environmental Planning Issues for the Southwest Border Communications Network	A-1
Figures	
1. Southwest Border Communications Network	1
2. The corridor area	2
3. Phase implementation, Southwest Border Communications Network	3
4. Corridor interagency communications system configuration	6
5. Repeater station configuration	7
A-1 Steps in the Army Environmental Impact Statement Process	A-7
A-2 Steps in the Army Environmental Assessment Process	A-9
A-3 Comparative timelines for overall project activities and environmental planning actions	A-11

INTENTIONALLY BLANK

**SOUTHWEST BORDER
COMMUNICATIONS NETWORK
EXECUTIVE SUMMARY**

Law Enforcement Requirements

Agents performing multiagency law enforcement missions along the United States borders need effective wireless communications. However, communication between existing law enforcement agency (LEA) systems is currently extremely limited. Several different radio frequency bands are used, and many systems use proprietary technologies that are incompatible with other manufacturers' systems. In response to the law enforcement need for reliable interagency wireless communications, the Electronic Proving Ground hereby defines the requirements for the Southwest Border Communications Network.

Network Design

The Southwest Border Communications Network requirements were developed in close cooperation with existing law enforcement communications systems and initiatives. Personnel from several LEAs were interviewed to determine the specific requirements of each agency. As a result, the Southwest Border Communications Network, when completed, shall have the capability to fulfill the following LEA user requirements:

- Provide communications between agencies in a timely manner
- Be simple for users to operate
- Provide both voice and data communications
- Provide effective encryption and security
- Be easily maintained and upgraded
- Be interoperable with existing agency networks.

The Southwest Border Communications Network shall be APCO-25-compliant. (APCO-25 is the Association of Public Safety Communications Officials, Inc., Project 25.) APCO-25 is an emerging set of standards which describe new, digital-technology, land-mobile radio systems for Public Safety use. APCO-25 promotes "open architecture," which will allow full compatibility among equipment items from different manufacturers, resulting in competition which will control pricing. The APCO-25 standards also describe a more efficient use of the limited radio frequency spectrum, methods to digitize and send voice and data, encryption standards, and interfaces to information systems. In short, the APCO-25 standards fulfill all of the requirements above (with the exception of interoperability with existing systems). The APCO-25 standards are supported by nearly all state and federal LEAs and communications regulatory agencies, as well as by most communications equipment manufacturers. The standards represent the future trends of LEA communications.

Interoperability with existing networks shall be achieved by having interfaces between the new Southwest Border Communications Network and the older communications systems. Until all network users have been issued Southwest Border Communications Network radios, this interface will allow LEAs to have limited access to the Southwest Border Communications Network via their existing radios.

Network Implementation

The Southwest Border Communications Network will be implemented in several phases:

- The first phase shall cover the corridor area between Tucson, Arizona, and Nogales, Arizona.
- Later phases could expand the area of coverage to include the entire United States–Mexico border.

**SOUTHWEST BORDER
COMMUNICATIONS NETWORK
SYSTEM REQUIREMENTS DOCUMENT**

Introduction

The Electronic Proving Ground (EPG) has developed the requirements for the Southwest Border Communications Network (SBCN). The SBCN will be an interagency communications system that will improve communications between law enforcement agencies (LEAs) operating within the area of coverage. Potential users include agencies at the local, state, and federal levels.

The SBCN will eventually provide service along the entire United States/Mexico border, as shown in figure 1, from the border to approximately 65 miles north of the border. The system will be implemented in phases. The first phase will provide service along the corridor extending between Nogales, Arizona and Tucson, Arizona. The corridor area is depicted in figure 2. Each phase of the SBCN is depicted in figure 3. This document addresses system requirements through Phase II.

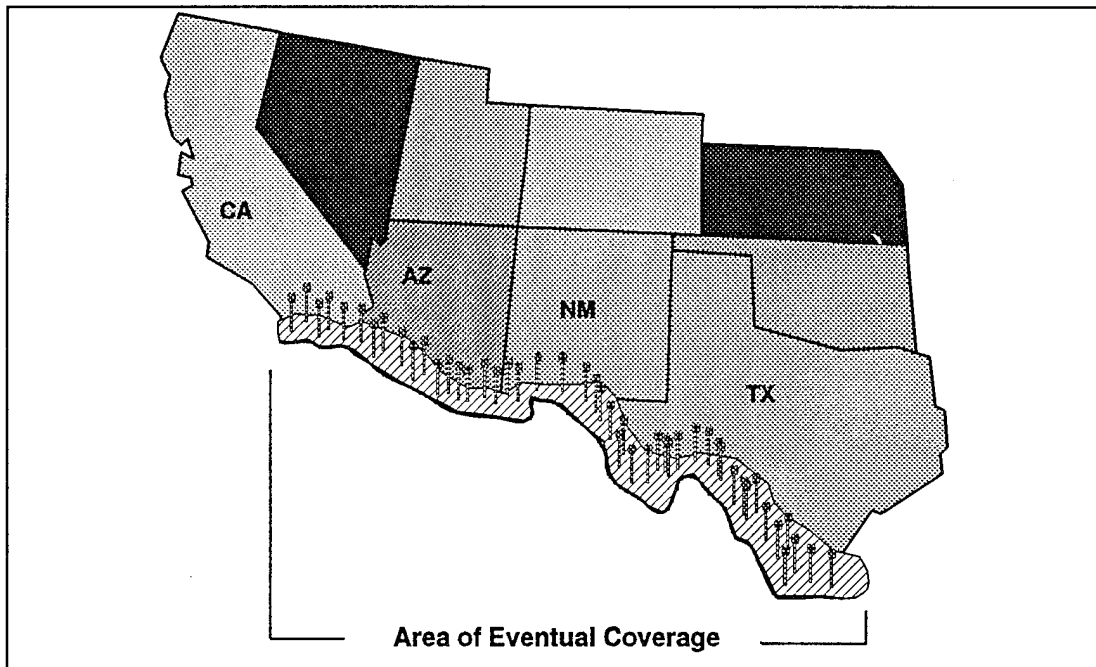

Figure 1. Southwest Border Communications Network.

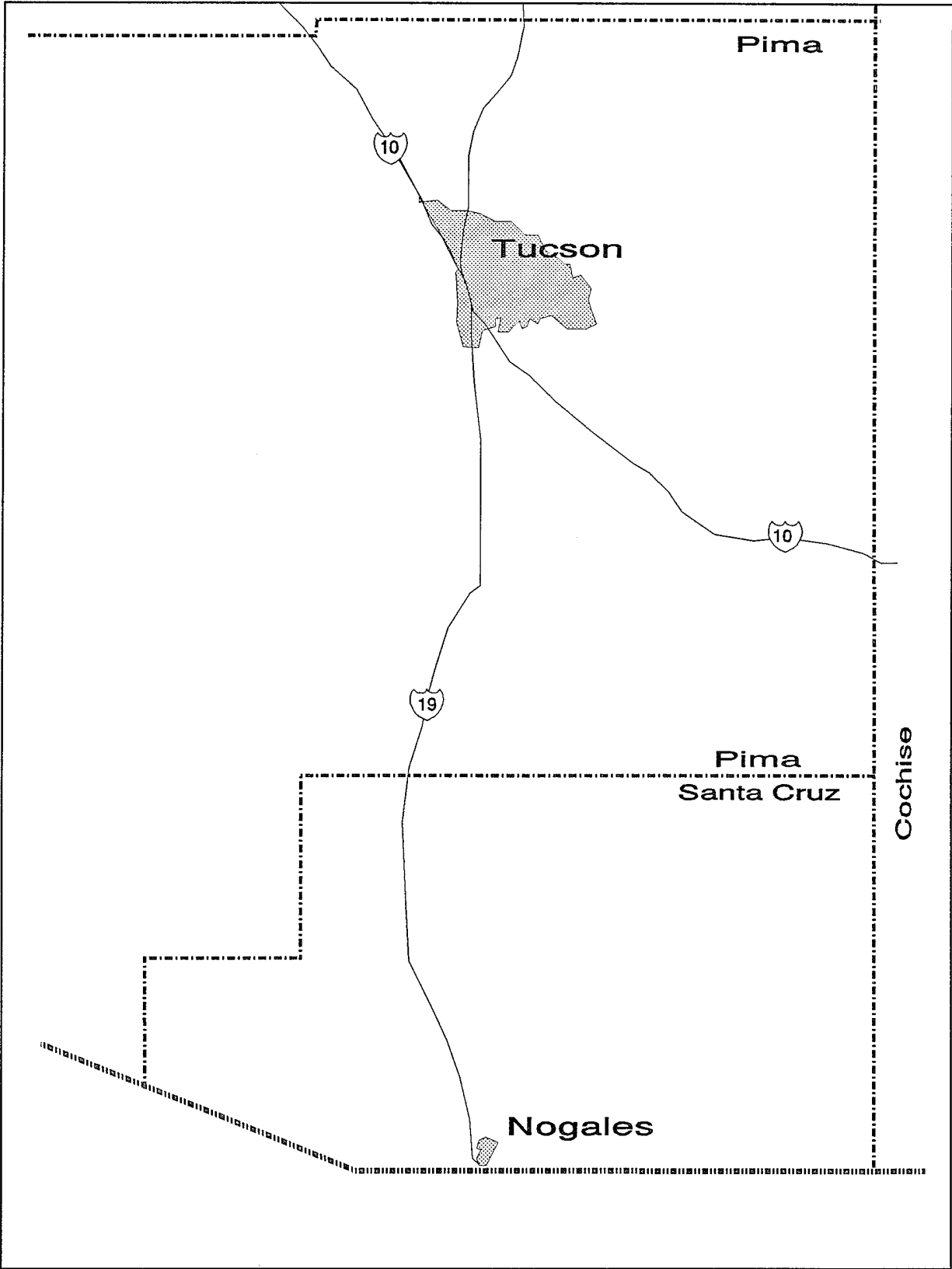

Figure 2. The corridor area.

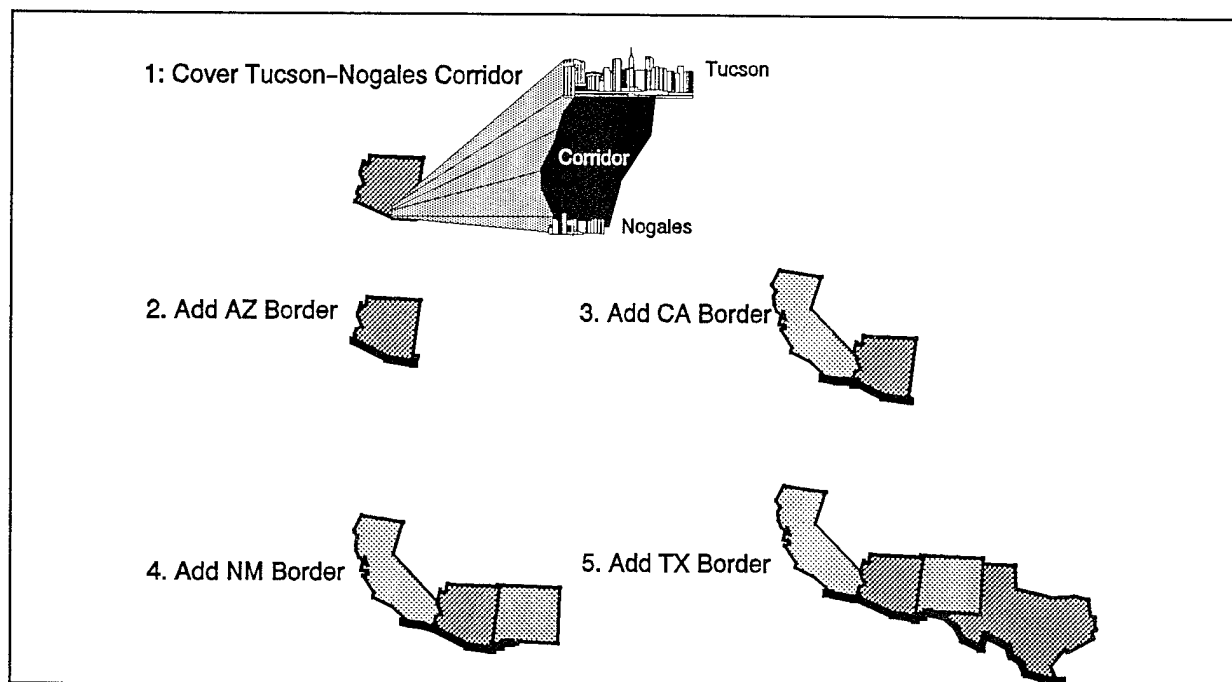

Figure 3. Phase implementation, Southwest Border Communications Network.

Current Interagency Communications

Interagency communication in the corridor area is accomplished via two "simplex" very high frequency (VHF) frequencies: (1) 155.475 MHz, the national law enforcement mutual aid frequency, and (2) 155.835 MHz, which is used in southeast Arizona for some interagency/intercounty purposes. In addition, the ultrahigh frequency (UHF) pair 460.375/465.375 MHz (paired for repeater operation) is set aside within Arizona for interagency use. Most of the proposed state and local users within the corridor area have access to one or more of these interagency frequencies.

The Arizona DPS has a system called the Interagency Radio System (IARS) that "cross-bands" the 155.475-MHz frequency with the 460.375/465.375-MHz pair. A transmission received by the IARS at 155.475 MHz is cross-banded and retransmitted at 460.375 MHz. A transmission received at 465.375 MHz is repeated at 460.375 MHz as well as cross-banded and retransmitted at 155.475 MHz. (Note: The IARS is currently designated for emergency use only.)

Another set of national mutual aid frequencies exists for LEAs: 866.0125, 866.5125, 867.0125, 867.5125, and 868.0125 MHz (and the corresponding frequencies 45 MHz lower). The lowest frequency, 866.0125 MHz, is the "calling" channel, which is used to initiate a call. The PCSD is the only agency in the corridor area that has radios that can operate in the "800 MHz" bands. Their radios, although not currently set up to access 866.0125 MHz, can be set up to do so.

Although originally intended for state and local LEAs, the interagency frequencies listed above can also be used (with the proper permission) by federal LEAs. Specifically, the

Border Patrol, DEA, and USCS have 155.475 MHz and 155.835 MHz programmed in their mobile radios.

The overall access of the corridor area users to the current interagency frequencies is summarized in the following table:

Agency	155.475 MHz	155.835 MHz	460.375/ 465.375 MHz	866.0125/ 821.0125 MHz
Arizona DPS	YES	NO (except in Phoenix - NA)	YES	NO
Border Patrol	YES	YES	NO	NO
DEA	YES	YES	NO	NO
Nogales PD	YES	YES	NO	NO
PCSD	YES, but limited	NO	NO	YES, but radio setup required
SCCSD	YES	YES	NO	NO
Tucson PD	YES	NO	NO	NO
USCS	YES	YES	NO	NO

DEA - United States Drug Enforcement Agency; DPS - State of Arizona Department of Public Safety; MHz - megahertz; NA - not applicable; PCSD - Pima County Sheriff's Department; PD - Police Department; SCCSD - Santa Cruz County Sheriff's Department; USCS - United States Customs Service

Requirements Overview

The Southwest Border Communications Network shall meet the following overall requirements:

- Provide communications between selected LEAs (see listing below)
- Be compliant with APCO-25 standards
- Interface with existing LEA communications equipment and frequencies
- Provide a Dispatch Center for the SBCN at the Santa Cruz County Sheriff's Department and the Pima County Sheriff's Department. The Dispatch Center shall be able to operate concurrently or independently

- Be able to transmit digital data, including digitized voice, computer files, graphical images and files, and electronic mail
- Provide effective encryption and security
- Provide talk group capability and control
- Be easily upgraded and maintained
- Be turn-key to the maximum extent possible.

The SBCN shall support two general classification of users:

- *Internal.* These are the agents who will have the APCO-25 compliant radios. These users will be able to take full advantage of all of the APCO-25 features, to include encryption, talk groups, and data transmission. The SBCN shall provide 110 mobile radios and 100 handheld radios for the Internal Users. The Electronic Proving Ground shall decide upon the distribution of the radios to the users.
- *External.* These are the agents who will use their existing analog radios to communicate through the SBCN. These users will be able to communicate with the Internal users, but without any of the advanced features of APCO-25. The SBCN shall provide no mobile or handheld radios to External Users.

The SBCN shall provide service for the key users listed below. There will be Internal and External users within each agency.

- Nogales Police Department (NPD)
- Pima County Sheriff's Department (PCSD)
- Santa Cruz County Sheriff's Department (SCCSD)
- State of Arizona Department of Public Safety (DPS)
- Tucson Police Department (TPD)
- United States Border Patrol (BP)
- United States Customs Service (USCS)
- United States Drug Enforcement Administration (DEA)

Recommended Approach

The following features, although not mandatory, should be considered in the implementation of the SBCN:

- The SBCN should be installed in/at existing communications facilities along the corridor. This approach would not only minimize installation costs but will also minimize the impact on the environment. The permits and studies, etc., required to add equipment to an existing site are much less complicated than those required for a new site. Environmental engineering research (ref) was performed for the Southwest Border Communications Network design. The results are in Appendix A.

- The SBCN should use the following locations to provide coverage along the corridor:

Location	Latitude, Longitude
Nogales Hill	31° 20' 20", 110° 57' 10"
Tucson Mountain	32° 14' 56", 111° 06' 59"
Keystone Peak	31° 52' 38", 111° 12' 54"

- The SBCN should use a minimum of three channels for trunked operation. An additional channel dedicated to trunking control could help decrease channel access times and overall throughput.
- Utilize the Arizona DPS IARS to provide connectivity between the SBCN and the existing analog communications systems. The interface between the SBCN and IARS should be done at the audio band level.

The recommended SBCN configuration is shown in figure 4. Figure 5 shows the recommended station configuration.

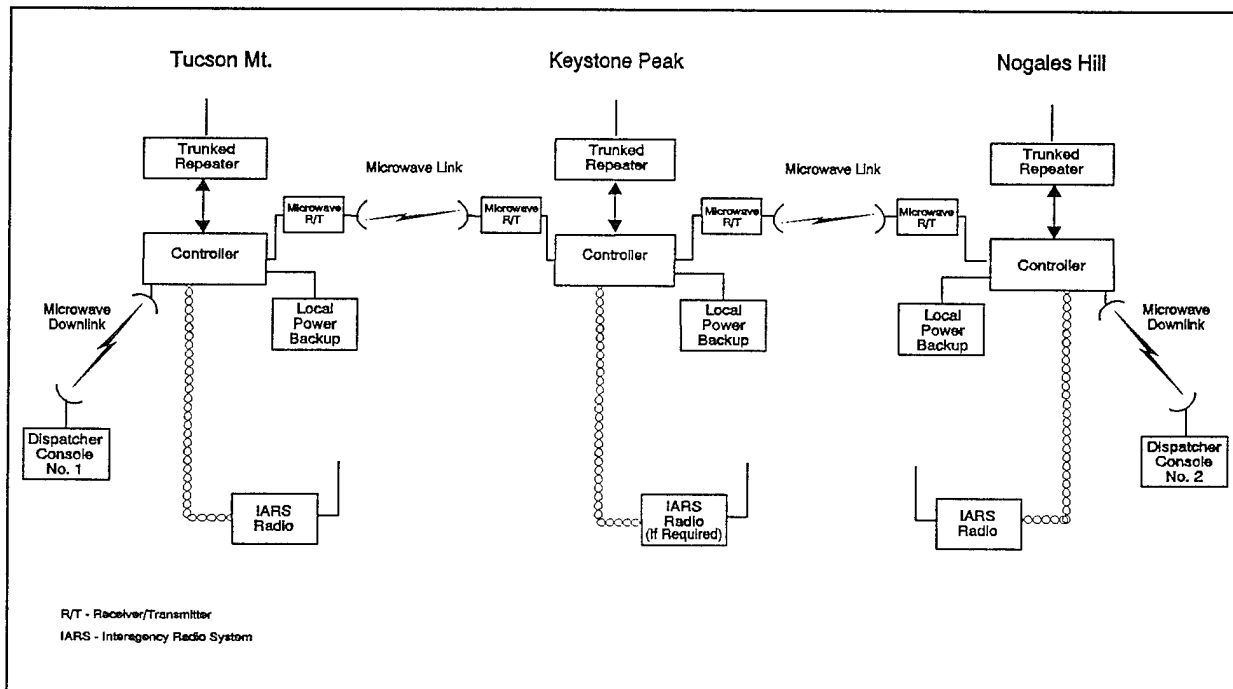

Figure 4. Corridor interagency communications system configuration.

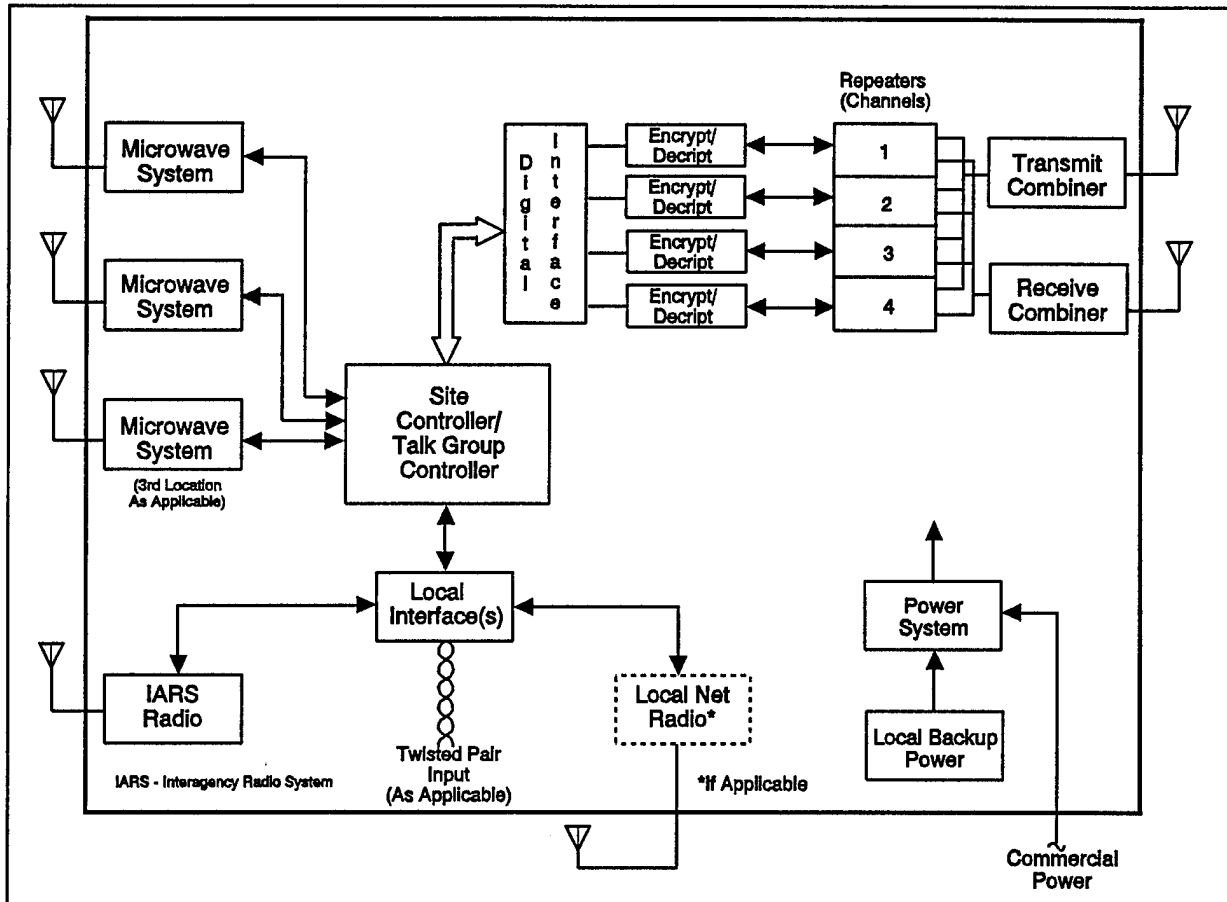

Figure 5. Repeater station configuration.

Reference

Dr. Heisler, David, Environmental Planning Issues for the Communications Program, Electronic Proving Ground, Fort Huachuca, Arizona, May 1995.

Abbreviations

APCO-25	Association of Public Safety Communications Officials, Inc., Project 25
BP	Border Patrol (United States)
DEA	Drug Enforcement Administration (United States)
DPS	Department of Public Safety (Arizona)
EPG	Electronic Proving Ground
IARS	Interagency Radio System
LEA	law enforcement agency
NA	not applicable
NPD	Nogales Police Department
PCSD	Pima County Sheriff's Department
R/T	receiver/transmitter

ref	reference
SBCN	Southwest Border Communications Network
SCCSD	Santa Cruz County Sheriff's Department
TPD	Tucson Police Department
UHF	ultrahigh frequency
USCS	United States Custom Service
VHF	very high frequency

**APPENDIX A.
ENVIRONMENTAL PLANNING ISSUES
FOR THE SOUTHWEST BORDER COMMUNICATIONS NETWORK**

INTENTIONALLY BLANK

Introduction

Southwest Border Communications Network (SBCN) environmental concerns fall into two categories: planning and operational compliance. Planning involves integrating analysis of environmental impacts into the design of the project so that the project will be implemented in the most environmentally beneficial (or, at least, environmentally benign) manner possible. This includes ensuring compliance with a wide range of environmental laws, including the National Environmental Policy Act (NEPA); the National Historic Preservation Act (NHPA); the Endangered Species Act (ESA); the Clean Air Act (CAA); the Clean Water Act (CWA); the Resource Conservation and Recovery Act (RCRA); the Comprehensive Environmental Response, Compensation, and Liability Act (CERCLA); and others, as well as their amendments and implementing regulations. For example, if a transmission tower is to be placed on a pristine mountain top, the site and access route would need to be evaluated for impacts to archaeological sites (under NHPA) and sensitive plant and animal species (ESA). If power were to be supplied by a generator, there would have to be an adequate berm around the fuel tank (RCRA), and the generator might need to be permitted as an air pollution emitter (CAA). If the site were the location of previous activity, it would have to be evaluated to determine whether the ground were polluted by spills of hazardous materials (CERCLA). Microwave transmissions would have to be controlled to avoid danger to humans (OSHA regulations). And so on. One or more regulatory agencies have oversight for each environmental law.

All of these types of potential impacts, and any others which might apply to a particular location and technical configuration, have to be studied, and the implementation modified where appropriate, during planning. The studies are documented in a variety of reports which are submitted to the appropriate regulatory agencies for review and approval. Through the NEPA process, the results are all brought together in a comprehensive planning document, either an environmental assessment (EA) or environmental impact statement (EIS). An EIS is prepared if there are significant environmental impacts, or if the level of impact is not known (see Programmatic Environmental Impact Statement below). An EA is prepared as a preliminary study to determine whether an EIS is required or if it is known in advance that an EIS will not be needed. An EA generally takes 3 to 6 months to complete, while an EIS usually requires 18 to 36 months and has a much higher level of public scrutiny.

During implementation and operation of the SBCN, operational compliance will be achieved by following all applicable environmental laws. This includes any mitigations that were identified during the NEPA process to reduce the environmental impact (e.g., training all construction workers on avoidance of sensitive animals in the area). As environmental laws and regulations change, the project should be reviewed to identify any impacts that those changes may have, to ensure continued compliance. Project locations and activities are also subject to inspection by regulatory agencies to verify operational compliance; notices of violation, with accompanying fines, may be issued for failure to comply.

Responsibility

As the implementing agency (Lead Agency in NEPA terminology) selected by the Office of National Drug Control Policy (ONDCP), the Army has responsibility for seeing that all environmental planning requirements are met. Because the operational system has the potential to be implemented in a variety of parts of the United States, operational control could be given to a variety of Federal, state, or local agencies. Each of these controlling agencies would be responsible for local operational compliance.

While under Army control, SBCN is subject to applicable Army regulations. AR 200-1, *Environmental Protection and Enhancement*, gives overall direction to the Post's environmental program. AR 200-2, *Environmental Effects of Army Actions*, regulates NEPA compliance and is based on NEPA and 40 CFR 1500-1508 (the Federal implementing regulations for NEPA). The program will also be subject to all other applicable Federal environmental laws and regulations, as well as Army Regulations such as AR 420-40 *Historic Preservation*. State laws and regulatory policies will also apply at those locations where SBCN is implemented.

Environmental Planning

The remainder of this chapter discusses environmental planning. Operational compliance will be dependent on the conditions in the specific locations where equipment is installed, the configuration of equipment at those locations, and those policies/requirements of the responsible regulatory agencies (responsibility for enforcing most Federal environmental laws is given to state agencies). Therefore, operational compliance requirements will be determined during environmental planning for each location.

Many of the environmental concerns arising from SBCN will be common to all locations. Other types of concerns, which may be specific to a location, can be identified. Examples of these were given in the first paragraph of this chapter. Therefore, a programmatic environmental analysis, which discusses the environmental issues related to SBCN regardless of where it is implemented, by what agency, and for what purpose, is appropriate. The programmatic analysis also identifies the issues that must be investigated at each implementation site, and puts limits on acceptable environmental impacts at those locations. Separate NEPA analyses will then be conducted for each group of implementation sites.

This approach—a programmatic analysis followed by site-specific analyses—will be taken for the following reasons:

- **Unknowns.** Many probable implementation sites are not yet identified. Future applications beyond the SBCN are not known. It is not practical to delay all environmental planning until all sites are known. Additionally, establishing the “ground rules” for implementation sites in the programmatic analysis will aid in site selection.
- **Significant issues.** The programmatic analysis will probably require preparation of an EIS because the overall program may raise a number of significant issues (see Programmatic Environmental Impact Statement below), and because of the potential

for significant environmental impacts at certain implementation locations (e.g., geography of an area may provide only a single practical location, on a significant archaeological site, to build a transmission tower). Most implementation locations, on the other hand, can be handled with EAs, which require much less time and effort.

- **Avoiding redundancy.** Issues which are addressed in the programmatic analysis need not be treated in the site-specific analyses. This reduces the scope and length of the latter.

Programmatic Environmental Impact Statement

If there are any significant issues related to SBCN, a Programmatic EIS, rather than a Programmatic EA, is required for the overall program. According to the following definition of "Significantly" in the Federal regulations, there may be a number of significant issues:

Significantly

"Significantly" as used in NEPA requires considerations of both context and intensity:

(a) Context. This means that the significance of an action must be analyzed in several contexts such as society as a whole (human, national), the affected region, the affected interests, and the locality. For instance, in the case of a site-specific action, significance would usually depend upon the effects in the locale rather than in the world as a whole. Both short- and long-term effects are relevant.

(b) Intensity. This refers to the severity of impact. Responsible officials must bear in mind that more than one agency may make decisions about partial aspects of a major action. The following should be considered in evaluating intensity:

(1) Impacts that may be both beneficial and adverse. A significant effect may exist even if the Federal agency believes that on balance the effect will be beneficial.

(2) The degree to which the proposed action affects public health or safety.

(3) Unique characteristics of the geographic area such as proximity to historic or cultural resources, park lands, prime farmlands, wetlands, wild and scenic rivers, or ecologically critical areas.

(4) The degree to which the effects on the quality of the human environment are likely to be highly controversial.

(5) The degree to which the possible effects on the human environment are highly uncertain or involve unique or unknown risks.

(6) The degree to which the action may establish a precedent for future actions with significant effects or represents a decision in principle about a future consideration.

(7) Whether the action is related to other actions with individually insignificant impacts. Significance exists if it is reasonable to anticipate a cumulatively significant impact on the environment. Significance cannot be avoided by terming an action temporary or by breaking it down into small component parts.

(8) The degree to which the action may adversely affect districts, sites, highways, structures, or objects listed in or eligible for listing in the National Register of Historic Places or may cause loss or destruction of significant scientific, cultural, or historical resources.

(9) *The degree to which the action may adversely affect an endangered or threatened species or its habitat that has been determined to be critical under the Endangered Species Act of 1973.*

(10) *Whether the action threatens a violation of Federal, State, or local law or requirements imposed for the protection of the environment (§ 1508.27).*

- **Positive impacts.** There should be a significant positive impact under Consideration (2). If not, why would the project exist? Consideration (1) states that positive, as well as negative, impacts must be considered.
- **Public controversy.** Under Consideration (4), there is likely to be significant public controversy. Immigrants rights groups may complain that the program is aimed at people crossing the border for political or economic reasons.
- **Unknown impacts.** Under Consideration (5), some of the towers may have to be located where they will impact significant archaeological sites, endangered species, etc. These will be avoided wherever possible, but it is not possible to be sure that there will not be a problem somewhere.

Figure A-1 shows the steps that will be required to complete the Programmatic EIS, as specified in AR 200-2. It also identifies which organization will be responsible for conducting each activity. Because a primary goal of NEPA is good project planning, a series of realistic alternative approaches to meeting the functional requirements of SBCN will have to be developed. Among these will be a No Action Alternative (i.e., SBCN is not implemented), which will provide a baseline against which the impacts of the other (Action) Alternatives can be measured. The end result of NEPA compliance will be to determine the environmentally best way to implement each of the alternatives and to measure the overall environmental impact of each alternative. In this way, the environment will be fully considered in selecting the best way to implement SBCN, and, whichever alternative is chosen, it will be designed in the best way environmentally.

Scoping is the process of determining which aspects of the environment may be impacted the most and therefore require indepth analysis. Much of this will be accomplished by an interdisciplinary team of environmental specialists, who will conduct preliminary evaluations of the impact of SBCN on their areas. Other agencies, such as the ONDCP, the U.S. Fish and Wildlife Service, and law enforcement agencies, will be designated as cooperating agencies and will have input into scoping (as well as commenting on the Draft and Final EISs). NEPA demands public input into the scoping process; therefore, at least one public scoping meeting will be needed.

Once scoping is completed, the environmental specialists will conduct detailed analyses of the areas selected. They will evaluate each of the alternatives. They will address short-term impacts during implementation, long-term impacts during operation, cumulative impacts which could arise in association with other projects, and indirect impacts. In many cases, their reports will identify the general ways in which SBCN could impact a portion of the environment, the way the site-specific analyses need to

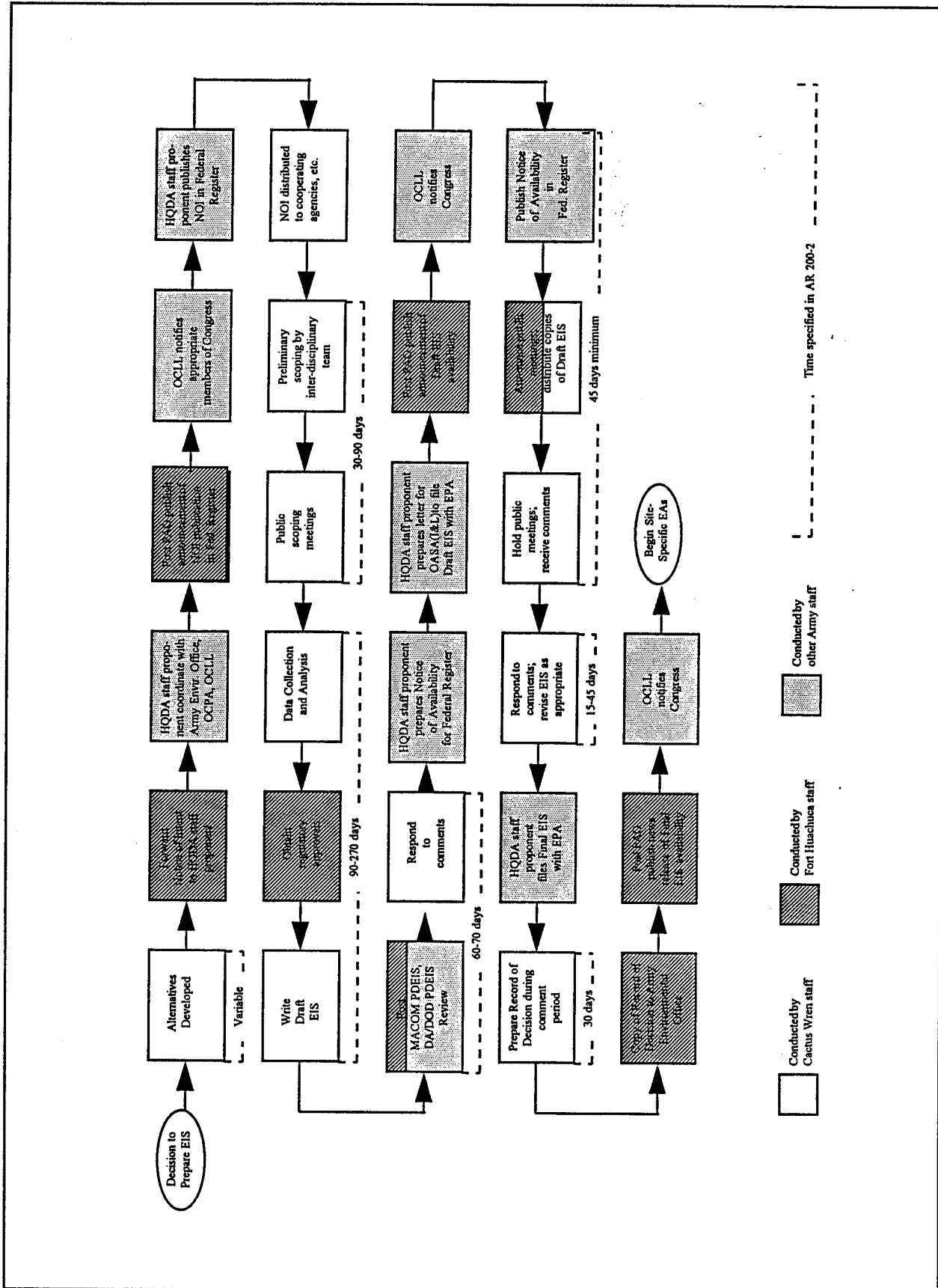

Figure A-1. Steps in the Army Environmental Impact Statement Process.

evaluate those potential impacts, and the range of acceptable mitigations. Each specialist will prepare a report appropriate to the regulatory agency with control over that portion of the environment. If no regulatory review is needed, the report will be adequate to withstand public scrutiny.

The analytical reports and the description of alternatives will form the basis for the Programmatic EIS document. Once the Draft EIS is complete and has passed Army review, a Notice of Availability will be published, through the Environmental Protection Agency, in the Federal Register. All persons who request a copy of the Draft EIS will be given one, along with a 45-day opportunity to comment. Every comment will be addressed. Appropriate comments will be incorporated into the EIS, and the Final EIS will be published, along with another notice in the Federal Register. The public will have 30 days to comment. At the end of that period, the Record of Decision, identifying which alternative has been selected for implementation, and the environmental impact of that selection, will be published. This will mark the completion of the Programmatic EIS.

Figure A-1 also shows typical times required for a number of steps in the EIS process. These times are those given in AR 200-2. They include all steps that will be the responsibility of the SBCN staff, except distributing the Notice of Intent, which will require 1 week or less. A Programmatic EIS can often be completed in less time because the environmental impact analyses are general, rather than involving detailed, often time-consuming study at specific locations. However, the timeline can be increased by public controversy.

Site-Specific Environmental Assessments

Once the Programmatic EIS has been completed, selecting implementation sites and completing NEPA compliance for those sites will be much easier. Each implementation of a complete system will need to be addressed in a single NEPA document. This is because single transmission or reception sites do not function in isolation but rather as part of a larger system of communication sites. NEPA requires that the impact of the entire system must be measured. For example, when SBCN is installed along the California-Mexico border, all of those sites, or at least all of the sites which could form a stand-alone system, will fall under a single EA. Each site will be evaluated according to the results of the Programmatic EIS.

Figure A-2 shows the steps involved in a site-specific EA. They form a subset of the steps in the Programmatic EIS process and the timeline is reduced accordingly. The major differences are that the EA is handled at the Post level without higher headquarters involvement, and public involvement is minimal. However, there are a number of factors which can lengthen the time to complete the site-specific EA, including the following:

- **Number of sites.** The more sites that are being studied, the longer that study takes.
- **Cultural resources.** Addressing cultural resources, particularly if ground is disturbed, can be a lengthy process.

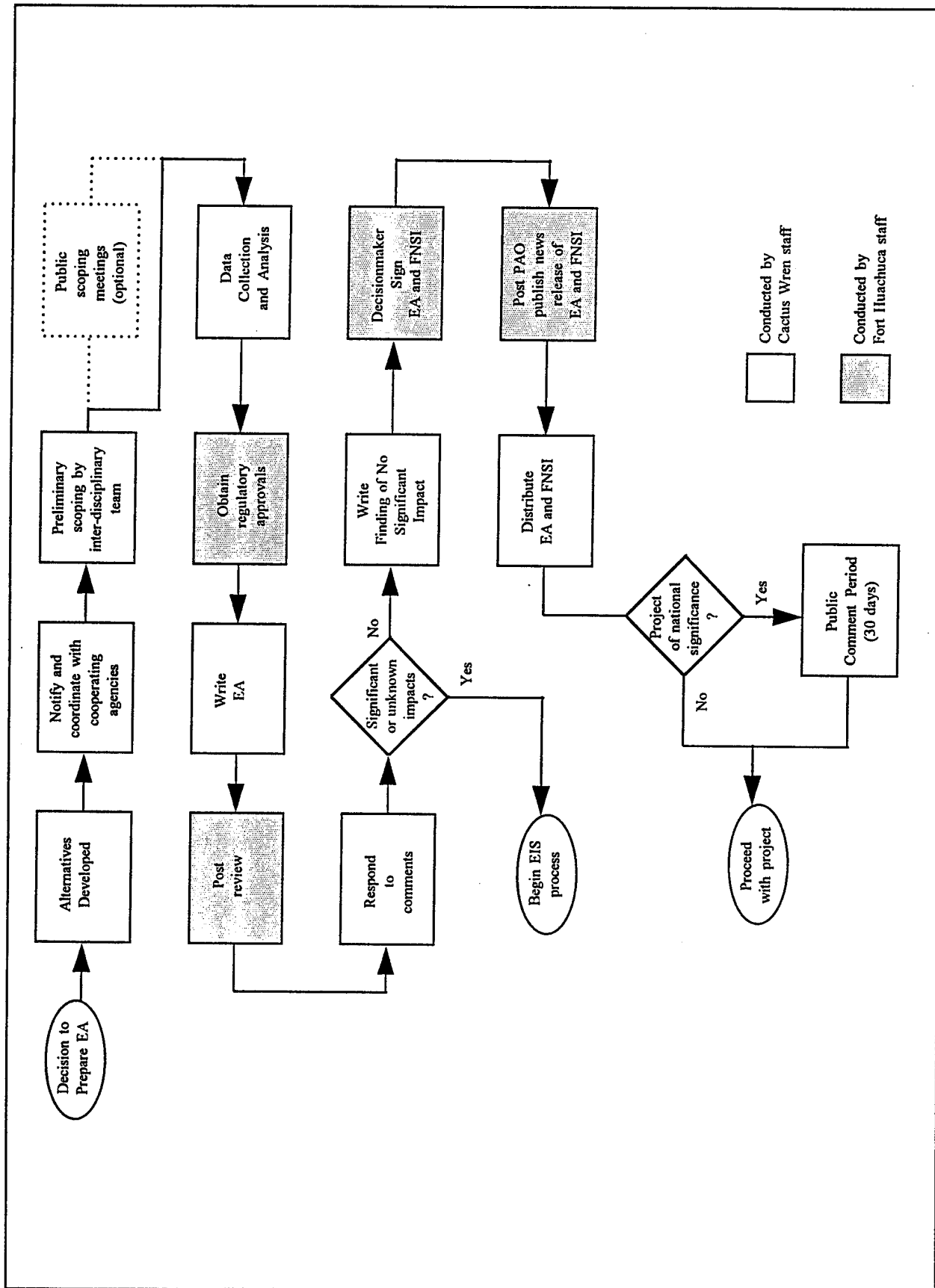

Figure A-2. Steps in the Army Environmental Assessment Process.

- **Native Americans.** If sites are located on Native American reservations, tribal agreement will have to be sought.
- **Plants and animals.** If threatened or endangered species could be impacted, developing appropriate mitigations that all parties agree to can be time consuming.

These factors will be minimized by taking the following steps:

- **Small sets of sites.** The SBCN will be broken into a series of smaller units, each of which could serve as a stand-alone communications network tying together law enforcement agencies in a small area. Thus, each EA will cover a minimal number of locations. If there are environmental problems at one location, progress on only a small portion of the SBCN will be impacted.
- **Flexibility.** Site location will be as flexible as possible so that, working with environmental specialists, sensitive areas will be avoided wherever possible.
- **Facility reutilization.** Existing facilities will be used wherever possible, unless those facilities have serious environmental problems.

Timeline

As noted in AR 200-2, *It is important to remember that next to the project itself, a properly prepared EIS may require the longest time to complete.* Furthermore, the earlier that environmental concern is integrated into SBCN, the easier it is to avoid crippling or time-consuming conflicts. Therefore, NEPA compliance will begin immediately. Figure A-3 shows the relationship of environmental planning to the overall SBCN program. Once alternatives are developed, the Notice of Intent to prepare the Programmatic EIS will be published in the Federal Register so that public scoping can begin. The remaining steps in the EIS process will proceed as shown in figure A-1. As soon as the Programmatic EIS is complete, work will begin on finalizing implementation site selection and associated EAs.

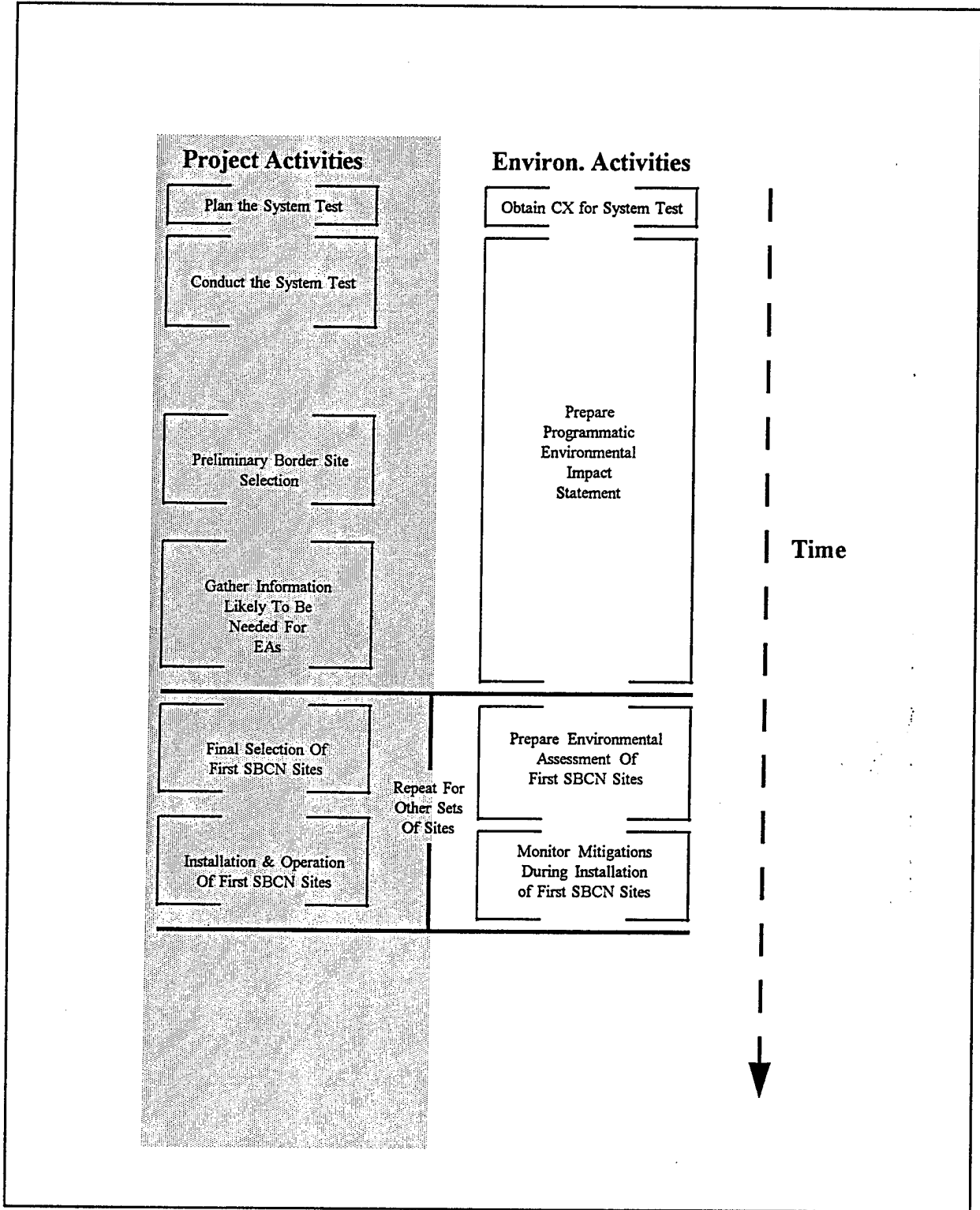

Figure A-3. Comparative timelines for overall project activities and environmental planning actions.

