

RL-TR-95-183
Final Technical Report
October 1995



AN ANALYSIS OF DELAY RESOLUTION FOR A TRUE TIME DELAY PHOTONIC BEAMFORMER

Stevens Institute of Technology

Henry Zmuda (Stevens Institute of Technology)
Edward N. Toughlian (SMC/CWP, Patrick AFB FL)

DTIC QUALITY INSPECTED 4

APPROVED FOR PUBLIC RELEASE; DISTRIBUTION UNLIMITED.

19960212 134

Rome Laboratory
Air Force Materiel Command
Griffiss Air Force Base, New York

This report has been reviewed by the Rome Laboratory Public Affairs Office (PA) and is releasable to the National Technical Information Service (NTIS). At NTIS it will be releasable to the general public, including foreign nations.

RL-TR-95-183 has been reviewed and is approved for publication.

APPROVED:

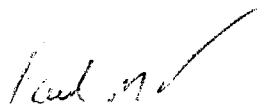
PAUL M. PAYSON
Project Engineer

FOR THE COMMANDER:



DONALD W. HANSON
Director of Surveillance & Photonics

If your address has changed or if you wish to be removed from the Rome Laboratory mailing list, or if the addressee is no longer employed by your organization, please notify RL (OCPC) Griffiss AFB NY 13441. This will assist us in maintaining a current mailing list.

Do not return copies of this report unless contractual obligations or notices on a specific document require that it be returned.

REPORT DOCUMENTATION PAGE

Form Approved
OMB No. 0704-0188

Public reporting burden for this collection of information is estimated to average 1 hour per response, including the time for reviewing instructions, searching existing data sources, gathering and maintaining the data needed, and completing and reviewing the collection of information. Send comments regarding this burden estimate or any other aspect of this collection of information, including suggestions for reducing this burden, to Washington Headquarters Service, Directorate for Information Operations and Reports, 1215 Jefferson Davis Highway, Suite 1204, Arlington, VA 22202-4302, and to the Office of Management and Budget, Paperwork Reduction Project (0704-0188), Washington, DC 20503.

1. AGENCY USE ONLY (Leave Blank)		2. REPORT DATE October 1995	3. REPORT TYPE AND DATES COVERED Final Oct 92 - Mar 94	
4. TITLE AND SUBTITLE AN ANALYSIS OF DELAY RESOLUTION FOR A TRUE TIME DELAY PHOTONIC BEAMFORMER			5. FUNDING NUMBERS C - F30602-93-C-0001 PE - 62702F PR - 4600 TA - P2 WU - PN	
6. AUTHOR(S) Henry Zmuda (Stevens Institute of Technology) Edward N. Toughlian (SMC/CWP, Patrick AFB FL)				
7. PERFORMING ORGANIZATION NAME(S) AND ADDRESS(ES) Stevens Institute of Technology Castle Point on the Hudson Hoboken NJ 07020			8. PERFORMING ORGANIZATION REPORT NUMBER N/A	
9. SPONSORING/MONITORING AGENCY NAME(S) AND ADDRESS(ES) Rome Laboratory (OCPC) 25 Electronic Pky Rome NY 13441-4515			10. SPONSORING/MONITORING AGENCY REPORT NUMBER RL-TR-95-183	
11. SUPPLEMENTARY NOTES Rome Laboratory Project Engineer: Paul M. Payson/OCPC/(315) 330-3148				
12a. DISTRIBUTION/AVAILABILITY STATEMENT Approved for public release; distribution unlimited.			12b. DISTRIBUTION CODE	
13. ABSTRACT (Maximum 200 words) The problem of obtaining a true-time-delay photonic beamformer has recently been a topic of great interest. This report examines the design, construction, and testing of a dynamic optical processor for the control of a 20-element phased array antenna operating at L-band (1.2-1.4 GHz). The approach taken here has several distinct advantages. The actual optical control is accomplished with a class of spatial light modulator known as a segmented mirror device (SMD). Optical splitting is efficiently accomplished using a diffractive optical element. The actual time delay is achieved using a single acousto-optic device for all the array elements. The topological configuration is an optical heterodyne system; hence high, potentially millimeter wave center frequencies are possible by mixing two lasers of slightly differing frequencies. Finally, the entire system is spatially integrated into a three dimensional glass substrate. Though the system is presently being configured as a beamformer, it has the ability to operate as a general photonic signal processing element in an adaptive (reconfigurable) transversal frequency filter configuration. Such systems are widely applicable in jammer/noise cancelling systems, broadband ISDN, and for spread spectrum secure communications.				
14. SUBJECT TERMS Radar beamformer, True time delay, Photonic beamformer			15. NUMBER OF PAGES 28	
			16. PRICE CODE	
17. SECURITY CLASSIFICATION OF REPORT UNCLASSIFIED	18. SECURITY CLASSIFICATION OF THIS PAGE UNCLASSIFIED	19. SECURITY CLASSIFICATION OF ABSTRACT UNCLASSIFIED	20. LIMITATION OF ABSTRACT UL	

PREFACE

The co-authors of this report, Dr. Henry Zmuda and Dr. Edward N. Toughlian, performed an equal share of the work, theoretical as well as experimental.

ABSTRACT

The problem of obtaining a true-time-delay photonic beamformer has recently been a topic of great interest. Many interesting and novel approaches to this problem have been studied. This report examines the design, construction and testing of a dynamic optical processor for the control of a 20-element phased array antenna operating at L-band (1.2-1.4 GHz). The approach taken here has several distinct advantages. The actual optical control is accomplished with a class of spatial light modulator known as a segmented mirror device (SMD). This allows for the possibility of controlling an extremely large number (tens of thousands) of antenna elements using integrated circuit technology. The SMD technology is driven by the HDTV and laser printer markets so ultimate cost reduction as well as technological improvements are expected. Optical splitting is efficiently accomplished using a diffractive optical element. This again has the potential for use in antenna array systems with a large number of radiating elements. The actual time delay is achieved using a single acousto-optic device for all the array elements. Acousto-optic device technologies offers sufficient delay as needed for a time steered array. The topological configuration is an optical heterodyne system, hence high, potentially millimeter wave center frequencies are possible by mixing two lasers of slightly differing frequencies. Finally, the entire system is spatially integrated into a three dimensional glass substrate. The integrated system provides the ruggedness needed in most applications and essentially eliminates the drift problems associated with free space optical systems. Though the system is presently being configured as a beamformer, it has the ability to operate as a general photonic signal processing element in an adaptive (reconfigurable) transversal frequency filter configuration. Such systems are widely applicable in jammer/noise canceling systems, broadband ISDN, and for spread spectrum secure communications.

This report also serves as an update of work-in-progress at the Rome Laboratory Photonics Center Optical Beamforming Lab. The multi-faceted aspects of the design and construction of this state-of-the-art beamforming project will be discussed. Experimental results which demonstrate the performance of the system to-date with regard to both maximum delay and resolution over a broad bandwidth are presented.

TABLE OF CONTENTS

I.	Introduction	4
II.	Photonic Microwave Delay Line	5
III.	True Time Delay Optical Beamforming System	8
IV.	System Performance	10
V.	Recommendations	16
VI.	References	19

I. INTRODUCTION

The use of photonic systems to control a phased array radar antenna system has been a topic of intense study. Perhaps the greatest attraction of optical beamforming methods is that the parallel nature of light along with the high packing density obtainable with photonics allows the formation of complex radiation patterns in a rapid and efficient manner. This in turn opens the door for the rather sophisticated parallel signal processing techniques necessary to make advanced antenna concepts such as smart skins and radar signature analysis a practical reality. Almost all approaches to dynamic beamforming fall into one of two categories; time steered and phase steered, with both having advantages as well as disadvantages. A common approach to obtain variable RF time delay via optical as well as electrical means has been through the use of constrained feed systems. Typically, this involves the switching in and out of varying lengths of transmission line or optical fiber [1]. Another interesting approach is to utilize a continuously tuneable laser source and highly dispersive fiber to achieve variable time delay [2]. This is accomplished by taking advantage of the property that different optical wavelengths will propagate in different modes on fiber. Fiber exhibiting high wavelength dispersion will thus have significant path length differences for each wavelength which can translate into a variable RF delay. Another continuously variable RF phase shifter using only optical components has been demonstrated by Soref [3]. This scheme employs an optical heterodyne system and has formed the basis for many phased array beamforming architectures [4]. Unlike the switched fiber delay line or dispersive fiber systems, optical heterodyne systems provide RF phase shifts which are independent of the RF frequency. This (unwanted) behavior results in a beamforming error known as squint, where the different frequency components of a modulated RF carrier will point in different directions. Elimination of this error requires true time delay, where the RF phase shift is linearly proportional to RF frequency. This report considers an optical processor which, over a prescribed frequency band, provides variable time delay performance by means of a optical heterodyne system.

A spatial integrated optic implementation of this system for phased array antennas is presently being constructed at the U.S. Air Force Rome Laboratory and some preliminary results are presented. At the heart of this application is a class of spatial light modulator (SLM) known as a deformable mirror device (DMD) [6]. In previous papers, the authors have demonstrated that these DMD's offer an attractive means of performing the optical signal processing required for dynamically steered optical beamforming systems [4].

In their most general sense, a DMD can be envisioned as an $N \times N$ array of independently controllable mirrors. Present day technology can provide in excess of 10^6 pixels occupying less than one square inch (including drive electronics!). These mirrors can translate or rotate, with the amount of movement obtainable dependent in large part on the fabrication process and material used. Excursions are on the order of several dozen optical wavelengths. This is sufficient for most phased array applications as demonstrated in the sections that follow. Much of the detail of the operation of the antenna system discussed has been the topic of several previous publications and hence only the highlights of the essential aspects are presented here. New to this report however is the analysis of the delay resolution, along with experimental verification of the ability of a photonic system of this type to be able to drive an actual antenna array.

II. PHOTONIC MICROWAVE DELAY LINE

Since an optical heterodyne system forms the basis for obtaining the antenna phase information, a brief description of the process is useful. Consider two light sources of slightly different frequencies; $A_1 \cos[(\omega_o + \omega_s)t + \phi]$ and $A_2 \cos[\omega_o t]$. Here ω_o represents the optical (radian) frequency, ω_s is the microwave/RF frequency by which the optical frequency is shifted, and ϕ is an optical phase shift. Further consider these two beams incident on a photodetector. Since such a detector responds only to the time averaged intensity, the resulting detected electrical signal will contain a term of the form $A_1 A_2 \cos(\omega_s t + \phi)$. We see that the output of the photodiode contains an RF frequency component equal to the optical beat frequency ω_M and an RF phase shift equal in angle to the optical phase shift ϕ . The mixing of two light sources in this way provides a means of obtaining substantial variable RF phase shift, achievable with optical components using phase shifts arising from optical path differences on the order of optical wavelengths. In addition to being able to obtain a variable phase shift, the above method also suggests the means to obtain a variable RF delay line; a very desirable device in many broadband microwave applications of which phased array antennas are an example.

By utilizing an acousto-optic cell as the frequency shifter in a heterodyne configuration, a continuously variable time delay is achieved. Referring to Figure 1, it is seen that the laser output of our delay line system is split into a plane wave local oscillator (upper path) which simply acts as a phase reference, and a beam which is sent to an acousto-optic (A/O) cell frequency shifter. The acousto-optic cell operates by applying the RF signal input to a piezoelectric transducer

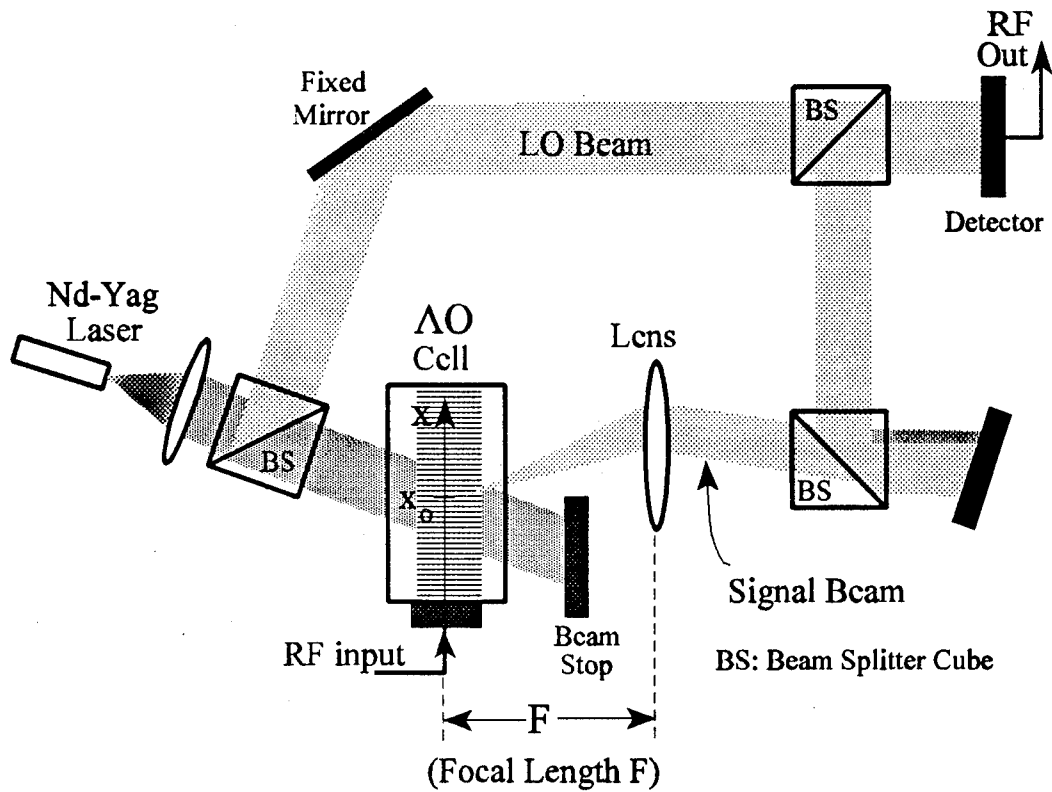

Figure 1: Frequency compensated heterodyne scheme.

mounted on a substrate which efficiently propagates an acoustic wave in the x direction as shown. The physical length of the cell times the velocity of the acoustic wave v_s provides a significant time delay τ across the length of the cell, or $\tau = x(t)/v_s$. Using the lensing system shown in the figure, each point along the path of the x axis in the A/O cell generates a plane wave which is incident on a tiltable mirror. The angle of this plane wave uniquely corresponds to a spatial coordinate $x(t)$ along the axis of propagation of sound in the cell. Figure 1 shows a single plane wave for a fixed value of time T (emanating from position x_0 in the figure). A single time delay T is obtained since two plane waves, one frequency shifted relative to the other, can interfere only when they are of the same angle (spatial frequency.) To see this, consider a plane wave which represents the signal beam. This can be expressed as

$$A_s e^{j[2\pi f_s t + 2\pi\alpha x + \phi_o]} \quad (1)$$

where $\omega_s = 2\pi f_s$ and where α represents the spatial frequency or tilt of the wave measured with respect to the plane wave reference beam phasor A_{LO} . Note that the reference phase of the local oscillator beam A_{LO} is arbitrarily taken to be zero. The photodetector integrates the intensity over all space of the summed signal and reference plane waves producing the electrical signal $i(t)$:

$$i(t) = \int_{-\infty}^{\infty} |A_{LO} + A_s e^{j[2\pi f_s t + 2\pi\alpha x + \phi_o]}|^2 dx \quad (2)$$

Which, neglecting the d.c. terms can be expressed as

$$i(t) = A_{LO} A_s \cdot \cos[2\pi f_s t + \phi_o] \cdot \delta(\alpha) \quad (3)$$

Where $\delta(\cdot)$ is the delta function [8]:

$$\delta(\alpha) = \int_{-\infty}^{\infty} e^{j2\pi\alpha x} dx \quad (4)$$

Clearly then by tilting the mirror (i.e. by varying α), we select which plane wave will beat with the local oscillator in the detector. Of course in a non-ideal system plane waves are not realizable, and therefore diffraction limiting effects give the system finite resolution. Delay resolution is considered in greater detail subsequently.

For the simplified system of Figure 1, a straightforward geometrical (ray) optical analysis shows that the time delay realized as a function of the lens focal length F , mirror tilt angle θ (assumed small so that $\sin \theta \approx \theta$), and acoustic velocity v_s is $T \approx 2\theta F/v_s$. Of course in a fully engineered system, the simplified optical system typically becomes more sophisticated due to design requirements.

A comment on carrier frequency and system bandwidth is appropriate. The single laser approach presented here limits the system bandwidth including the carrier to a few gigahertz. Carrier frequencies into the millimeter wave frequency range and beyond are easily obtained with an optical system utilizing two phase-locked lasers operating at slightly different colors or wavelengths [10]. The A/O cell is placed in the path of one of these laser beams to provide RF modulation.

It is to be emphasized that the delay achieved is *continuously variable*. This, and the ability to integrate many such delay lines in an efficient manner provides a unique capability which can be applied to traditional microwave systems as we will now discuss.

III. TRUE TIME DELAY OPTICAL BEAMFORMING

Perhaps the greatest strength of photonics is its ability to perform parallel processing by exploiting the spatial nature of light. A compact system incorporating the multiple delay lines necessary for phased array antennas is the spatially integrated optic implementation of Figure 2.

Such an arrangement provides mechanical stability, eliminates the drift problems encountered in free space optical systems as well as provides the ability to achieve higher packing densities. As discussed, the basis of this integrated optical implementation is a class of spatial light modulator known as a deformable mirror device. This type of device can be utilized to provide the phase shifts necessary to achieve a true time delay radiation pattern. To demonstrate this, consider the well known equation for the array factor of a linear array of isotropic point sources spaced a distance d apart:

$$AF = \sum_m A_m \exp j(\varphi_m + md \frac{\omega_c + \omega_s}{c} \sin \theta) \quad (5)$$

where ω_c is the RF carrier frequency, ω_s the modulating frequency, θ is the given observation angle, c is the speed of light, and φ_m is the required RF phase shift for the m^{th} array element with amplitude coefficient A_m .

We see that to steer an electromagnetic (far field) plane wave an angle θ requires delaying the signal to the n^{th} antenna element by an amount $T_n(\theta) = nd \sin(\theta)/c$ where

c is the speed of light, n is the element number and d is the element spacing. The inability to realize a variable delay line in an efficient manner, i.e. to vary $T_n(\theta)$ continuously, has restricted the use of phased array antennas systems to narrow band applications where the delay is approximated by a simple phase shift.

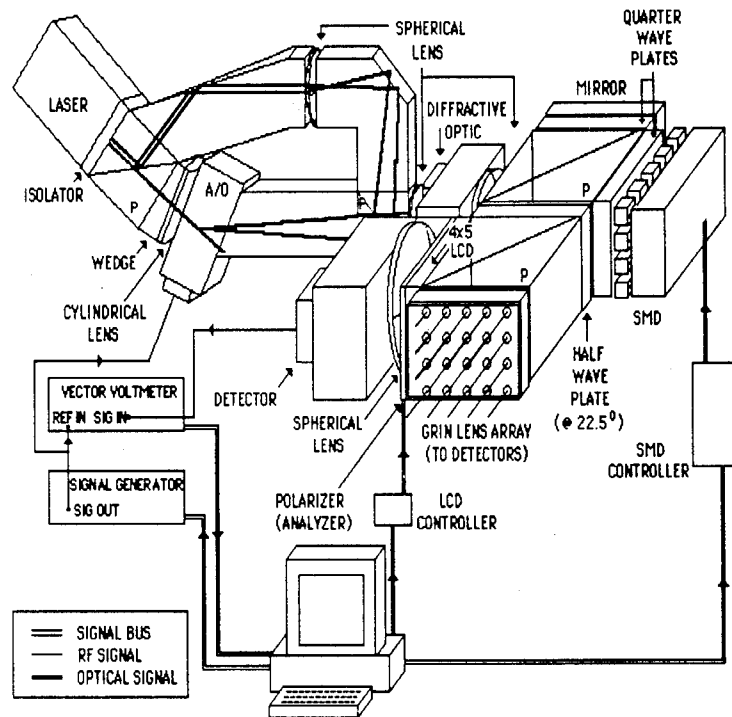

Figure 2: Spatial integrated optical implementation.

The system illustrated in Figure 2 has been described in great detail in a previous report, and the reader is referred to this report for a specific description of all the components including their specifications [11]. It should be noted however that unique to this system is the use of the diffractive optic device for replication of the signal beam in an efficient manner to provide twenty identical delay lines.

IV. SYSTEM PERFORMANCE

The delay resolution and temporal effects are very important though independent issues in regard to how they influence the performance of the antenna system. Delay resolution is determined by the accuracy to which one can control the DMD element. Temporal effects result in signal dispersion are caused by the bandpass nature of the system. These dispersive effects come about in two ways; one is the PZT transducer on the AO cell and another is the ability to image the local oscillator beam in the AO cell. The overall limit in this regard is the bandpass characteristic of the AO cell transducer. This dictates how tightly one must focus the LO image in the AO cell so that it has no effect on the dispersive characteristics of the overall system. In this way, the guidelines for the optical system design are established, as will be shown.

It is important to note that each delay line can be individually controlled and is *totally independent* of the others in the antennal control system. Each photo-detector located at an antenna element has its own unique “view” of the A/O cell based on the angular position of its corresponding DMD element. This “view” is independent of where any other detector may be looking. This “view” can be thought of as an image of the local oscillator beam inside the A/O cell.

To fully appreciate the resolving ability of the photonic delay line, two very important points must be understood. The first is that the size of the LO image inside the A/O cell affects only the *temporal* characteristics of the output signal and in *no way* affects the spatial distribution of the antenna array or the ability to resolve delay at the element level. Secondly the resolution of the DMD element combined with the magnification effects of the lensing system and the velocity of propagation in the A/O cell affect the delay resolution. This is independent of the size of the LO image pointer inside the A/O cell. These two effects shown at the output of the phased array system are illustrated in the Figure 3 below. Note that the DMD itself has a resolution limit, determined by the resolution of the controlling power supply. The DMD used in the present system has a 4 micron displacement, a 7mm pixel size, and can be rotated $2^{10} = 1024$ increments (based solely on the specifications of the digitally controlled d.c. power supply). The angular resolution of the DMD ($\Delta\phi$) as shown in Figure 4. Solving for $\Delta\phi$ results in a DMD resolution of 1.116μ radians.

We now determine the spatial resolution (displacement) (Δx) inside A/O cell due to a $\Delta\phi$ displacement of the mirror element as seen in Figure 5.

$$\Delta x = F \tan 2 \Delta \phi \quad (7)$$

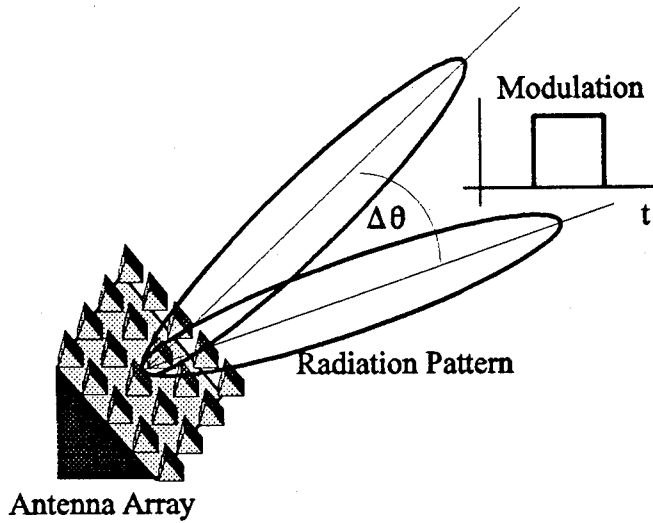

Figure 3: *LO pointer size effects the temporal characteristics (signal amplitude vs. time) only, whereas LO pointer position resolution effects the steering resolution ($\Delta\theta$) only.*

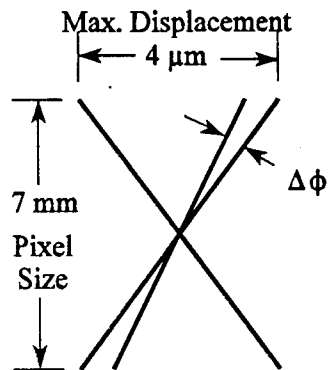

Figure 4: *DMD pixel tilt.*

$$\tan (\Delta \phi) = \frac{\frac{\text{Maximum Displacement}}{\text{Number of Resolvable Displacements}}}{\frac{\text{Pixel Size}}{2}} \quad (6)$$

We calculate the delay resolution by converting the spatial displacement Δx to a temporal displacement Δt ,

$$\Delta t = \frac{\Delta x}{v} \quad (8)$$

The system under construction has an effective focal length of $F = 36$ mm (approximately), and where $v = 5120$ m/s is the velocity of acoustic propagation in the A/O cell. This results in a delay resolution of roughly 15.69 picoseconds.

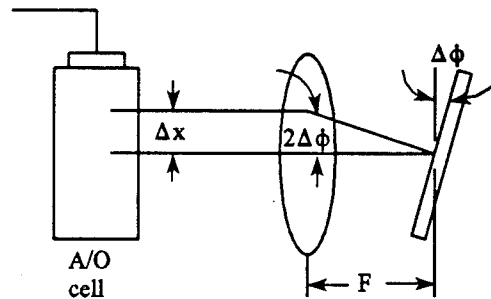

Figure 5: Displacement of beam inside the A/O cell (Δx) due to tilt of the mirror element ($\Delta \phi$).

Now note several important points. The total distance across the 20 element phased array antenna is approximately 3 feet. To achieve a beam steer to broadside (90°) would require a delay of approximately 3 nanoseconds. Therefore with the calculated

delay resolution of 15.69 picoseconds, approximately $3 \text{ nsec}/15.69 \text{ psec} = 191$ different steer angles (in each direction ($\pm 90^\circ$)) or about 380 steer angles total might be possible. Since it is not likely that a $\pm 90^\circ$ steer angle will be used, a somewhat smaller number of angles will be achievable. Probably on the order of about two thirds (more realistically $\pm 60^\circ$) or **about 125 steer angles might be possible.**

Also note that the maximum delay realizable for this system, with this DMD, is $1024\Delta t \approx 16 \text{ nsec}$. This delay is more than sufficient to support the Martin Marietta antenna and in fact should support a 20 ft antenna at $\pm 60^\circ$ steer angles.

Temporal Effects: The RF frequency response of this system is now a separate issue. Ideally, the image of the local oscillator in the AO cell is a point focus or a spatial delta function. Of course this is not possible in a real system and a diffraction effect results. This manifests itself in the RF regime as dispersion. We might like to think of an ideal system as one in which the "pointer" in the AO cell is a delta function. The real system will have a "pointer" of non-zero width. The effect of the LO image size on the output signal can be understood from Fourier analysis as follows.

The signal inside the A/O cell is effectively understood to be the product of the LO image being moved past the input RF signal (refer to Figure 6). The response $h(t)$ is mathematically expressed as the convolution of the RF input signal $f(t)$ with the pointer function $g(t)$, or

$$h(t) = \int_{\text{active A/O cell length}} g(x) f(t-x) dx \quad (9)$$

Recall the identity

$$g(t) = \int_{-\infty}^{\infty} g(x) \delta(t-x) dx \quad (10)$$

Clearly when the pointer function $f(t) = \delta(t)$ then $h(t) = g(t)$ as required. The RF signal $g(t)$ is simply the bandlimited version of the actual RF input signal. The bandlimiting comes about from the piezoelectric transducer on the A/O cell crystal.

It is important to observe that the above discussion is based on a single delay line element in the phased array system; i.e. it is independent of how the other LO pointers in the array are directed with respect to the pointer in question. Since the individual

signals don't interfere with each other, their temporal signal outputs are independent of the location of any other pointer. Since the pointers do not interfere with each other they may overlap with no deleterious effects and therefore the temporal output signals are independent of one another.

As a specific example of these ideas, let us compute the temporal and physical extent of the RF signal and LO image inside the A/O cell for the system under construction. The temporal bandwidth is the reciprocal of the RF bandwidth (B) or

$$\tau_{RF} = 1/B \quad (11)$$

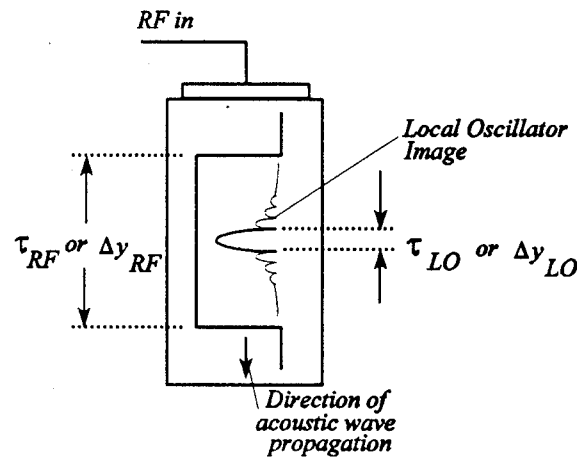

Figure 6: Representation of RF signal and LO image in both temporal extent (τ) and physical extent (Δy) inside the A/O cell.

This translates to a spatial in the A/O cell extent of

$$\Delta y_{RF} = v \tau_{RF} \quad (12)$$

The local oscillator occupies a length Δy_{LO} , where

$$\Delta y_{LO} = \lambda F / 2\pi r \quad (13)$$

This is completely equivalent to the diffraction limited spot size of the (collimated) LO beam with diameter $2r$ and wavelength λ , and focused through a lens of focal length F . Here $\lambda = 1.3\mu$, $r = 1.2$ mm, and $F = 36$ mm. Substituting, we find that (using $v = 5120$ m/s as before) $\Delta y_{RF} = 51.2 \mu\text{m}$ and $\tau_{RF} = 2.43$ nsec. The temporal extent of the LO image τ_{LO} can be inverted to imply an effective bandwidth (B_{LO}) which can be supported by this system, or

$$B_{LO} = 206.2 \text{ MHz}$$

Thus, the Fourier transform of the LO image is bandpass in nature and has an equivalent bandwidth of greater than 200MHz. This result indicates that since the support bandwidth of the LO (B_{LO}) is greater than the bandwidth of the RF input signal, the finite size of the LO image pointer has no effect on the output signal.

Confusion may come about because of the similar relative sizes of the LO image (Δy_{LO}) and the RF beam (Δy_{RF}) inside the A/O cell. As shown here, the LO beam is as large as necessary to support the 200MHz RF bandwidth without temporal distortion of the input signal. The relative sizes of the LO image and RF beams inside the A/O cell have nothing to do with delay resolution, as shown in these previously.

VI. RECOMMENDATIONS

Seemingly, the greatest problem associated with optically controlled phase array antennas has been the inability to achieve steerable true time delay performance without introducing switched fiber delay lines. This report offers a simple solution to this problem and updates work-in-progress on a variable photonic microwave delay line system for a twenty element phased array antenna operating in L-band. Although the system has been presented in a phased array framework, it is expected that the delay line will find application in other areas of microwave signal processing technology.

A few words are in order regarding testing of the broadband optical beamforming system. The intent of this effort was to prove the concept that an integrated optical system could be fabricated that would yield a large number of stable parallel variable delay lines operating in parallel. In addition a model which accurately portrayed the performance characteristics of the system based on its components was to be realized. The optical beamforming system was built using readily available commercially available off-the-shelf components and was not an attempt to optimize the system for a specific application. If the results of the optical beamformer table-top tests provided a realistic model such that a high level of confidence in this model could be assured then the testing would be a complete success. This model could then be used to determine the feasibility of developing a system for a specific application. If in addition the systems also works in such a way that reasonable L-band radiation patterns are generated in an anechoic chamber than those results would be well beyond initial expectations. Anechoic chamber testing is not a necessity since radiation patterns can be synthesized from the optical bench test data using any number of CAD packages. The difference between bench-top testing and the anechoic chamber testing is the difference between research and development. As pointed out earlier, the goal of this effort should be to

- i) prove the concept and
- ii) to develop a model which a developer could have some level of confidence in from which to put together a system based on a specific application.

A good deal of fine tuning is of course necessary for the full potential of this

delay line system to be realized. The question of this optimal lensing arrangement is best addressed once the details of a particular application and its performance criteria have been specified. Although optical systems have obvious advantages with regard to size, weight, power efficiency, etc. over their microwave counterparts, the underlying goal must be to at least meet if not exceed the performance of electronic systems with regard to key parameters such as noise and dynamic range. These tests are currently in progress and will be reported at a later date.

ACKNOWLEDGEMENTS

The authors wish to express their thanks to Paul Payson and John Malowicki of the Rome Laboratory Photonics Center at Griffiss Air Force Base for their most valued insight and assistance.

REFERENCES

- [1] Tamburrini, M., M. Parent, L. Goldberg, and D. Stillwell, "*Optical feed for a phased array microwave antenna*," **Electronics Letters**, Vol. 23, No. 13, pp. 680-681, 18th June 1987.
- [2] D. Norton, S. Johns, C. Keefer, and R. Soref, "*Tunable Microwave filtering using high dispersion fiber time delays*," **IEEE Photonics Technology Letters**, vol. 6, no. 7, pp. 831-832, 1994.
- [3] Soref, R.A., "*Voltage-controlled optical/RF phase shifter*," **IEEE J. Lightwave Technology**, Vol. LT-3, pp.992-997, 1985.
- [4] Toughlian, E.N., H. Zmuda, and P. Kornreich, "*A deformable mirror based optical beamforming system for phased array antennas*," **IEEE Photonic Technology Letters**, Vol. 2, No. 6, pp. 444-446, June 1990.
- [5] E.N Toughlian and H. Zmuda, "*A photonic variable RF delay line for phased array antennas*," **IEEE Journal of Lightwave Technology**.
- [6] Boysel, R.M., J.M. Florence, and W.-R. Wu, "*Deformable mirror light modulators for image processing*," **SPIE Proceedings**, Vol. 1151, pp. 183-194, Aug. 1989.
- [7] J.R. Leger, G.J. Swanson, and W.B. Veldkamp, "*Coherent laser addition using binary phase gratings*," **Applied Optics**, Vol. 26, No. 20, pp. 4391-4399, 15 Oct. 1987.
- [8] Papoulis, A, **The Fourier Integral**, New York: McGraw-Hill, 1960.
- [9] Simonis, G.J. and K.G. Purchase, "*Optical generation, distribution, and control of microwaves using laser heterodyne*," **IEEE Transactions on Microwave Theory and Techniques**, Vol. 38, No. 5, pp. 667-669, May 1990.
- [10] Monsay, Evelyn; private communication.

- *[11] E.N. Toughlian, P. Payson, J. Malowicki, H. Zmuda, and D. Samberg, *Optical Beamforming for Phased Array Applications*, RL-TR-94-31 **Technical Report**, U.S. Air Force Rome Laboratory, 1994.

*Although this report references the limited document listed above, no limited information has been extracted. Report distribution is limited to USGO Agencies and their contractors; critical technology.

MISSION
OF
ROME LABORATORY

Mission. The mission of Rome Laboratory is to advance the science and technologies of command, control, communications and intelligence and to transition them into systems to meet customer needs. To achieve this, Rome Lab:

- a. Conducts vigorous research, development and test programs in all applicable technologies;
- b. Transitions technology to current and future systems to improve operational capability, readiness, and supportability;
- c. Provides a full range of technical support to Air Force Materiel Command product centers and other Air Force organizations;
- d. Promotes transfer of technology to the private sector;
- e. Maintains leading edge technological expertise in the areas of surveillance, communications, command and control, intelligence, reliability science, electro-magnetic technology, photonics, signal processing, and computational science.

The thrust areas of technical competence include: Surveillance, Communications, Command and Control, Intelligence, Signal Processing, Computer Science and Technology, Electromagnetic Technology, Photonics and Reliability Sciences.