



The contents of this report are not to be used for advertising, publication, or promotional purposes. Citation of trade names does not constitute an official endorsement or approval of the use of such commercial products.



PRINTED ON RECYCLED PAPER

Technical Report CERC-95-19  
December 1995

# **Periodic Inspection of Jetties at Manasquan Inlet, New Jersey**

## **Report 1 Armor Unit Monitoring for Period 1984-1994**

by Robert R. Bottin, Jr.

U.S. Army Corps of Engineers  
Waterways Experiment Station  
3909 Halls Ferry Road  
Vicksburg, MS 39180-6199

Jeffrey A. Gebert

U.S. Army Engineer District, Philadelphia  
100 Penn Square East  
Philadelphia, PA 19107-3390

Report 1 of a series

Approved for public release; distribution is unlimited

Prepared for U.S. Army Corps of Engineers  
Washington, DC 20314-1000



**US Army Corps  
of Engineers**  
Waterways Experiment  
Station

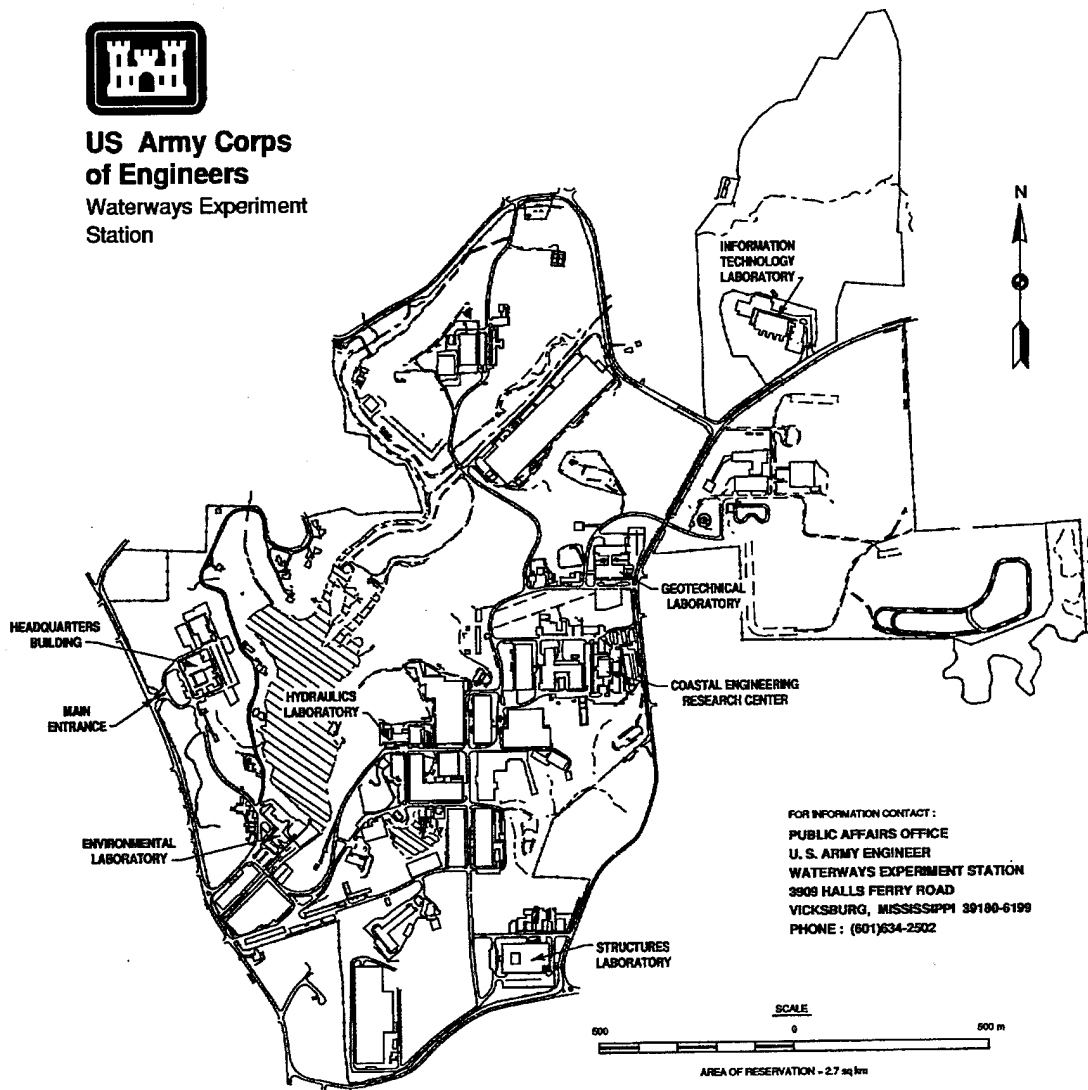

### Waterways Experiment Station Cataloging-in-Publication Data

Bottin, Robert R.

Periodic inspection of jetties at Manasquan Inlet, New Jersey.  
Report 1, Armor unit monitoring for period 1984-1994 / by Robert R.  
Bottin, Jr., Jeffrey A. Gebert ; prepared for U.S. Army Corps of Engineers.  
75 p. : ill. ; 28 cm. — (Technical report ; CERC-95-19 rept.1)  
Includes bibliographic references.

Report 1 of a series.

1. Jetties — New Jersey — Manasquan River. 2. Breakwaters — New  
Jersey — Manasquan River. I. Gebert, Jeffrey A. II. United States.  
Army. Corps of Engineers. III. U.S. Army Engineer Waterways  
Experiment Station. IV. Coastal Engineering Research Center (U.S.  
Army Engineer Waterways Experiment Station) V. Title. VI. Title: Armor  
unit monitoring for period 1984-1994. VII. Series: Technical report (U.S.  
Army Engineer Waterways Experiment Station) ; CERC-95-19 rept.1.  
TA7 W34 no.CERC-95-19 rept.1

# Contents

---

Preface .....	iv
Conversion Factors Non-SI to SI (Metric)	
Units of Measurement .....	v
1—Introduction .....	1
Work Unit Objective and Monitoring Approach .....	1
Project Location and Brief History .....	2
Purpose of the Study .....	7
2—Prior Monitoring of the Site .....	12
Initial (Comprehensive) Monitoring .....	12
Subsequent Armor Unit Monitoring .....	18
3—Current Monitoring Plan and Data Comparison .....	19
Targeting and Ground Surveys .....	19
Aerial Photography .....	23
Photogrammetric Analysis of Armor Units .....	26
Broken Armor Unit Survey .....	28
Comparison of Armor Unit Movement Data .....	35
4—Summary .....	67
References .....	69
SF 298	

# Preface

---

The study reported herein was conducted as part of the Monitoring Completed Coastal Projects (MCCP) Program. Work was carried out under Work Unit 22121, "Periodic Inspections." Overall program management for the MCCP Program is accomplished by the Hydraulic Design Section of Headquarters, U.S. Army Corps of Engineers (HQUSACE). The Coastal Engineering Research Center (CERC), U.S. Army Engineer Waterways Experiment Station (WES), is responsible for technical and data management and support for HQUSACE review and technology transfer. Technical Monitors for the MCCP Program are Messrs. John H. Lockhart, Jr., Barry W. Holliday, and Charles B. Chesnutt (HQUSACE). The Program Manager is Ms. Carolyn M. Holmes (CERC).

This report is the first in a series which will track the long-term structural response of the jetties at Manasquan Inlet, NJ, to their environment. The information contained in this report was gathered as a result of land and aerial survey work conducted by Aerial Data Reduction Associates, Inc., under contract to the Corps of Engineers, and broken armor unit surveys conducted by Messrs. Robert R. Bottin, Jr. and Larry R. Tolliver, and Dr. Jimmy E. Fowler (CERC).

The work was conducted during the period November 1993 through November 1994 under the general supervision of Dr. James R. Houston and Mr. Charles C. Calhoun, Jr., Director and Assistant Director, CERC, and under the direct supervision of Messrs. C. E. Chatham, Jr., Chief, Wave Dynamics Division, and Dennis G. Markle, Chief, Wave Processes Branch. This report was prepared by Mr. Bottin, CERC, and Mr. Jeffrey A. Gebert, U. S. Army Engineer District, Philadelphia.

Director of WES during the investigation and publication of this report was Dr. Robert W. Whalin. Commander was COL Bruce K. Howard, EN.

*The contents of this report are not to be used for advertising, publication, or promotional purposes. Citation of trade names does not constitute an official endorsement or approval of the use of such commercial products.*

# Conversion Factors, Non-SI to SI (Metric) Units of Measurement

---

Non-SI units of measurement used in figures, plates, and tables of this report can be converted to SI (metric) units as follows:

<b>Multiply</b>	<b>By</b>	<b>To Obtain</b>
cubic yards	0.7646	cubic meters
feet	0.3048	meters
inches	2.54	centimeters
miles (U.S. statute)	1.609347	kilometers
pounds (mass)	0.4535924	kilograms
tons (2,000 pounds, mass)	907.1847	kilograms

# 1 Introduction

---

## Work Unit Objective and Monitoring Approach

The objective of the Periodic Inspections work unit in the Monitoring Completed Coastal Projects (MCCP) research program is to periodically monitor selected coastal structures to gain an understanding of the long-term structural response of unique structures to their environment. These periodic data sets are used to improve knowledge in design, construction, and maintenance of both existing and proposed future coastal projects. These data will also avoid repeating past design mistakes which have resulted in structural failure and/or high maintenance costs. Past projects monitored under the MCCP program, and/or structures with unique design features that may have application at other sites, are considered for inclusion in the periodic inspections monitoring program. Selected sites are presented as candidates for development of a periodic monitoring plan. Those sites receiving favorable response during MCCP program review are inspected and a monitoring plan is developed and presented for approval. Once the monitoring plan for a site is approved by the field review group and funds are provided, monitoring of the site is initiated. Normally, base conditions are established and documented in the initial effort. The site then is reinspected on a periodic basis (frequency of surveys is based on a balance of need and funding for each monitoring site) to obtain long-term structural performance data.

Relatively low-cost remote sensing tools and techniques, with limited ground truthing surveys, are the primary inspection tools used in the monitoring efforts. Most periodic inspections consist of capturing above-water conditions of the structure at periodic intervals using high-resolution aerial photography. A visual comparison of periodic aerial photographs is used to gauge the degree of in-depth analysis required to quantify structural changes (primarily armor unit movement). Data analysis involves using photogrammetric techniques developed for and successfully applied at other coastal sites. At sites where local wave data are being gathered by other projects or agencies and acquisition of these data can be made at a relatively low cost, wave data are correlated with structural changes. In areas where these data are not available, general observations and/or documentation of major storms occurring in the locality are presented along with the monitoring data. Ground surveys are

limited to the level needed to establish the accuracy of the photogrammetric techniques.

When a coastal structure is photographed at low tide, an accurate permanent record of all visible armor units is obtained. Through the use of stereoscopic, photogrammetric instruments in conjunction with photographs, details of structural geometry can be defined at a point in time. By direct comparison of photographs taken at different times, as well as the photogrammetric data resolved from each set of photographs, geometric changes (i.e. armor unit movement and/or breakage) of the structure can be defined as a function of time. Thus, periodic inspections of the structures will capture permanent data that can be compared and analyzed to determine if structure changes are occurring that indicate possible failure modes and the need to monitor the structure(s) more closely. The jetties at Manasquan Inlet, NJ, were nominated for periodic monitoring by the U.S. Army Engineer District, Philadelphia (CENAP).

## Project Location and Brief History

Manasquan Inlet is located on the Atlantic Coast of New Jersey approximately 42 km (26 miles)<sup>1</sup> south of Sandy Hook and 37 km (23 miles) north of Barnegat Inlet (Figure 1). The inlet provides the northernmost connection between the ocean and the New Jersey Intracoastal Waterway. Reliable surveys as early as 1839 reveal that the inlet has migrated between its present location and 1.6 km (1 mile) north (U.S. Army Engineer District (USAED), Philadelphia 1978). On a number of occasions prior to jetty completion in 1931, the inlet closed completely.

Stabilization of the inlet was first attempted between 1881 and 1883 with the construction of timber jetties. Both these and subsequent timber jetties built in 1922 failed, leading to Congressional authorization of the present project layout in 1930. The project involved construction of two rubble jetties, with steel sheet-pile cores, spaced 122 m (400 ft) apart. Built to a crest height of +4.3 m (+14 ft) mean low water (mlw)<sup>2</sup>, the jetties extend to the -3-m (-10-ft) contour. The north jetty was 375 m (1,230 ft) long, and the south jetty was 314 m (1,030 ft) in length. Core stone weight ranged from 45.4 to 226.8 kg (100 to 500 lb), and 1,814-kg (2-ton) capstone was used for armor. Originally, the authorized channel was 76.2 m (250 ft) wide and 3 m (10 ft) deep between the jetties and 91.4 m (300 ft) in width and 2.4 m (8 ft) in depth for the interior channels. In 1935, the authorized channel depth between the

---

<sup>1</sup> Units of measurement in the text of this report are shown in SI (metric) units, followed by non-SI (British) units in parentheses. In addition, a table of factors for converting non-SI units of measurement used in figures in this report to SI units is presented on page v.

<sup>2</sup> All elevations (el) and depths cited herein are in meters (feet) referred to mean low water (mlw).

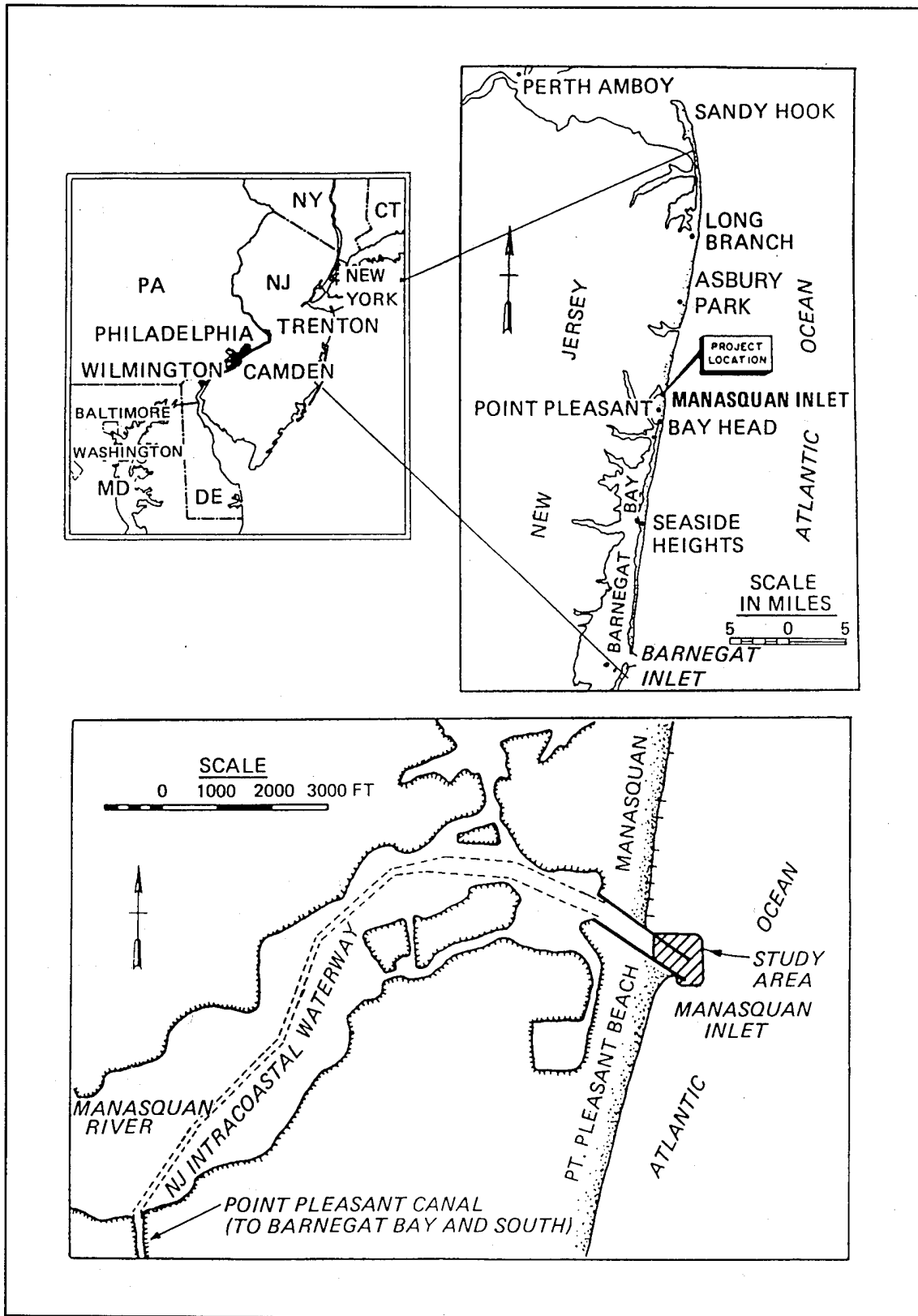

Figure 1. Location and vicinity map

jetties was increased to 4.3 m (14 ft) and the interior channel depth to 3.7 m (12 ft). The current project is shown in Figure 2.

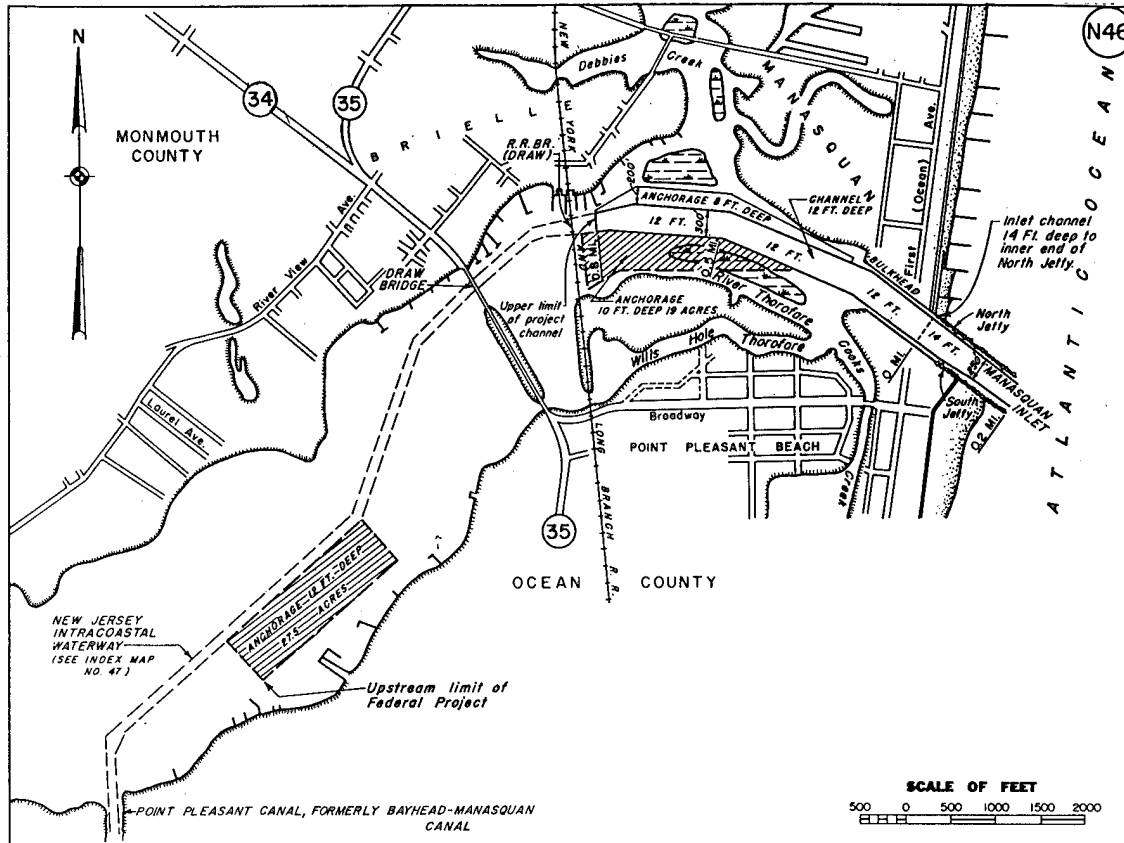

Figure 2. Manasquan Inlet, NJ

Through the mid-1970's, the jetties were repeatedly damaged by storms and structural settlement (USAED, Philadelphia 1978). Beach erosion north of the inlet and accretion to the south emphasized the impact of the jetties on the littoral system. Shoaling of the navigation channel increased as the structures deteriorated and became more permeable. Numerous repairs were attempted, using armor stone of up to 10,890 kg (12 tons), without success. Additional information relative to the repair and rehabilitation history of the jetties can be found in Smith (1988). A 1962 aerial view of the deteriorated jetties is shown in Figure 3.

The most recent rehabilitation of the jetties was completed in 1982 and involved the use of 14,515-kg (16-ton) dolos armor units (Figures 4 and 5). Dolos armor units were invented by Eric M. Merrifield, a South African engineer, in 1963. Various views of a dolos armor unit are shown in Figure 6. Initial model tests of the unit were performed by the South African Council for Scientific and Industrial Research in 1965 and indicated that dolosse had a stability coefficient higher than other armor units (Merrifield 1974).

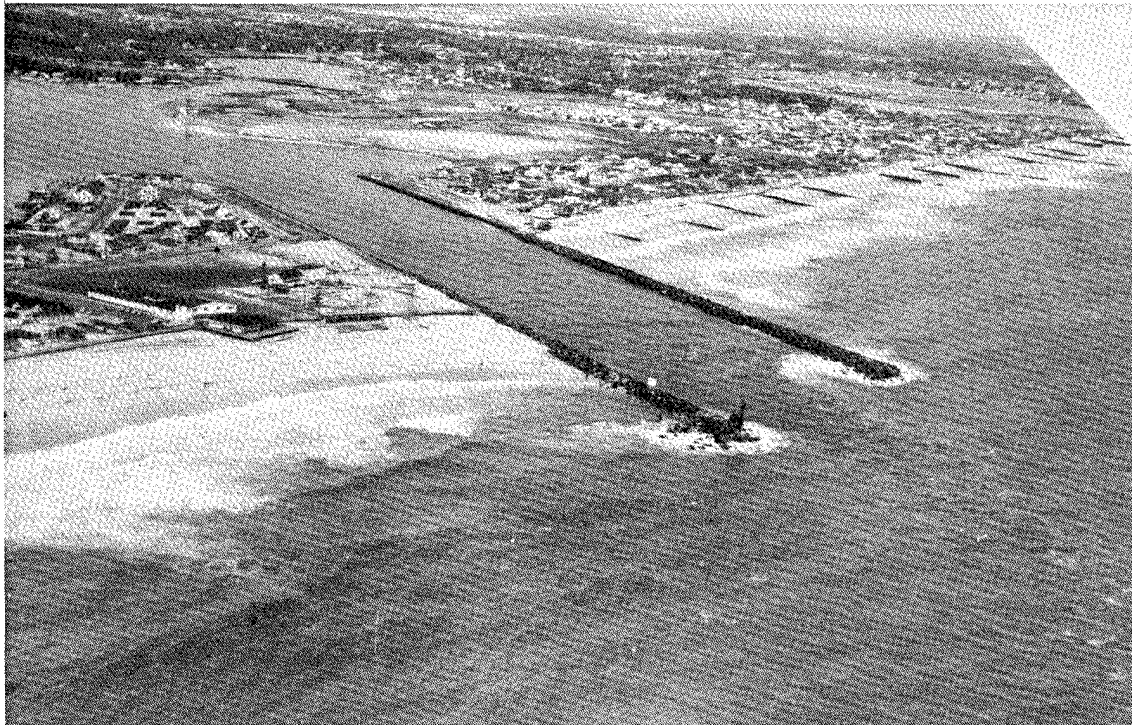

Figure 3. Aerial view of deteriorated jetties at Manasquan Inlet, March 1962

Subsequently, other laboratories, including the Corps of Engineers, tested dolosse and verified that they were more stable than natural stone and other existing concrete armor unit designs. Dolosse have been used on over 50 coastal projects throughout the world.

Rehabilitation was completed on the south jetty in 1980. The first step of the rehabilitation of the jetties was to disassemble them. Sand was excavated and dislodged armor stones were reshaped to the design configuration prior to dolos placement. Dolosse were placed on the outer 122 m (400 ft) of the north, or channel side of the jetty, around the structure head, and along the outer 36.5 m (120 ft) of the structure's south side. Dolosse extended to -3 m (-10 ft) on the channel side at a slope of one vertical on two horizontal (1V:2H). Inshore of the dolos section, the side slopes were armored with a single layer of 10,885-kg (12-ton) stones. The outer 122 m (400 ft) of the jetty crest is a concrete cap; the inner portion of the jetty crest is 10,885-kg (12-ton) stone. The original sheet-pile core was left in place in its existing condition. The sheet pile extends the entire length of the jetty and has a top elevation of +2.4 m (+8 ft). Work on the north jetty began in 1980 and was completed in 1982. Dolosse were placed along the outer 76 m (250 ft) of the jetty on its north side, around its head, and along the outer 27.5 m (90 ft) on the channel side. Stone was used to armor the inner portions of the jetty on both sides. Construction drawings of typical cross sections for the jetties are shown in Figures 7 and 8.

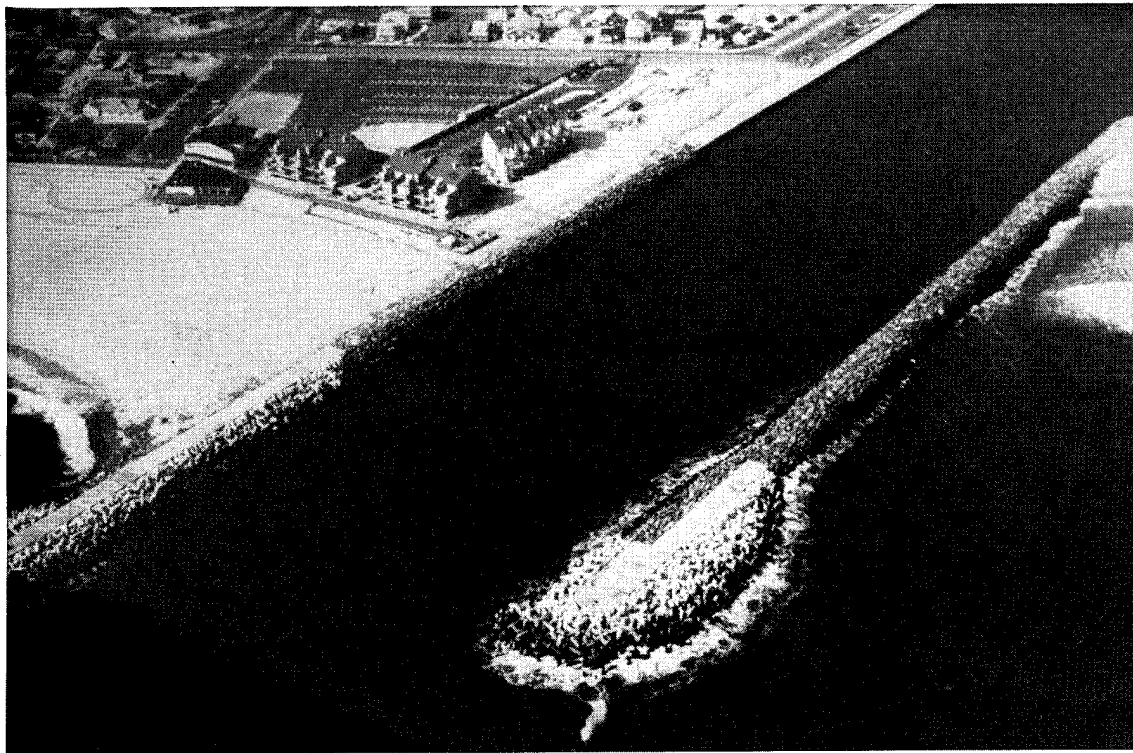

Figure 4. Aerial view of dolosse at heads of jetties after 1982 rehabilitation

Breaking waves accompanied by storm surge were identified as the principal cause of damage to the structures at the inlet. Unfortunately, no reliable wave data existed at the site. Therefore, the design wave height was based on depth-limited breaking wave criteria. The design water depth at the seaward end of the jetties was calculated to be 8.8 m (29 ft), based on a mlw depth at the structure toe of 5.5 m (18 ft), plus 1.65 m (5.5 ft) maximum spring tide height, plus 1.65 m (5.5 ft) storm surge elevation. Using procedures from the *Shore Protection Manual* (1984) for a range of wave periods from 7 to 15 sec and assuming a nearshore bottom slope of 0.01, values of the breaking wave height ranged up to 7.5 m (24.7 ft) for the longer wave periods. The design breaking wave height selected was, therefore, 7.6 m (25 ft). Several alternative designs were considered for the rehabilitation, including 10,885- and 18,145-kg (12- and 20-ton) stone and 14,515-kg (16-ton) dolosse. Dolosse were determined to have the lowest annual maintenance cost and were selected for construction. Based on engineering judgement, a decision was made to reinforce the dolosse with epoxy-coated reinforcing rods as shown in Figure 9.



Figure 5. Closer view of 16-ton dolos armor units on the heads of Manasquan Inlet jetties

## Purpose of the Study

The purposes of the study reported herein were as follows:

- a. Develop methods using limited land-based surveying, aerial photography, and photogrammetric analysis to assess the long-term stability response of dolos armor units on the Manasquan Inlet jetties.
- b. Conduct land surveys, broken armor unit inspections, aerial photography, and photogrammetric analyses to test and improve developed methodologies and accurately define armor unit movement above the waterline.
- c. Reexamine data obtained in previous monitoring efforts and determine and define any changes occurring to the dolos armor layers.

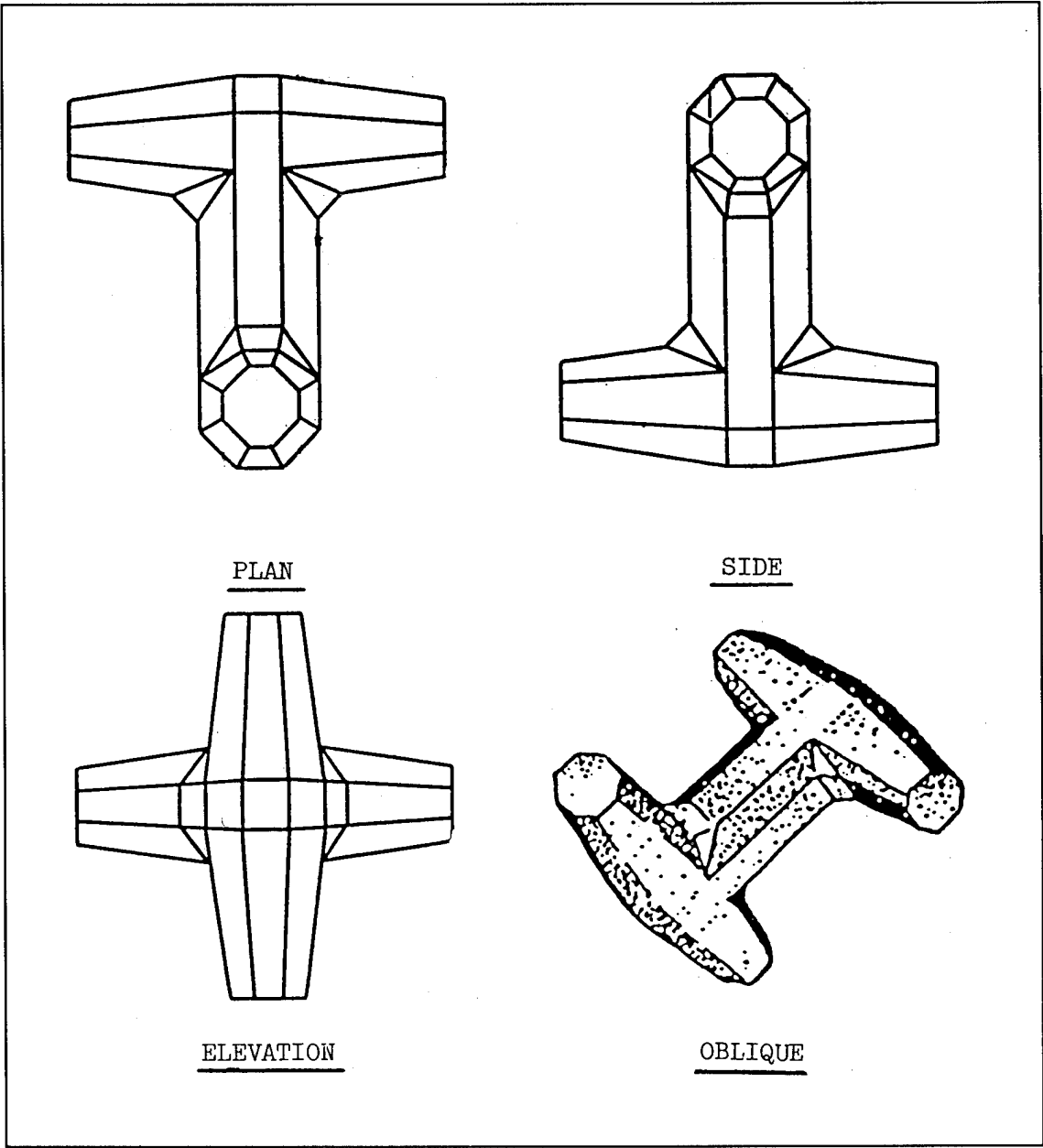

Figure 6. Various views of a dolos armor unit

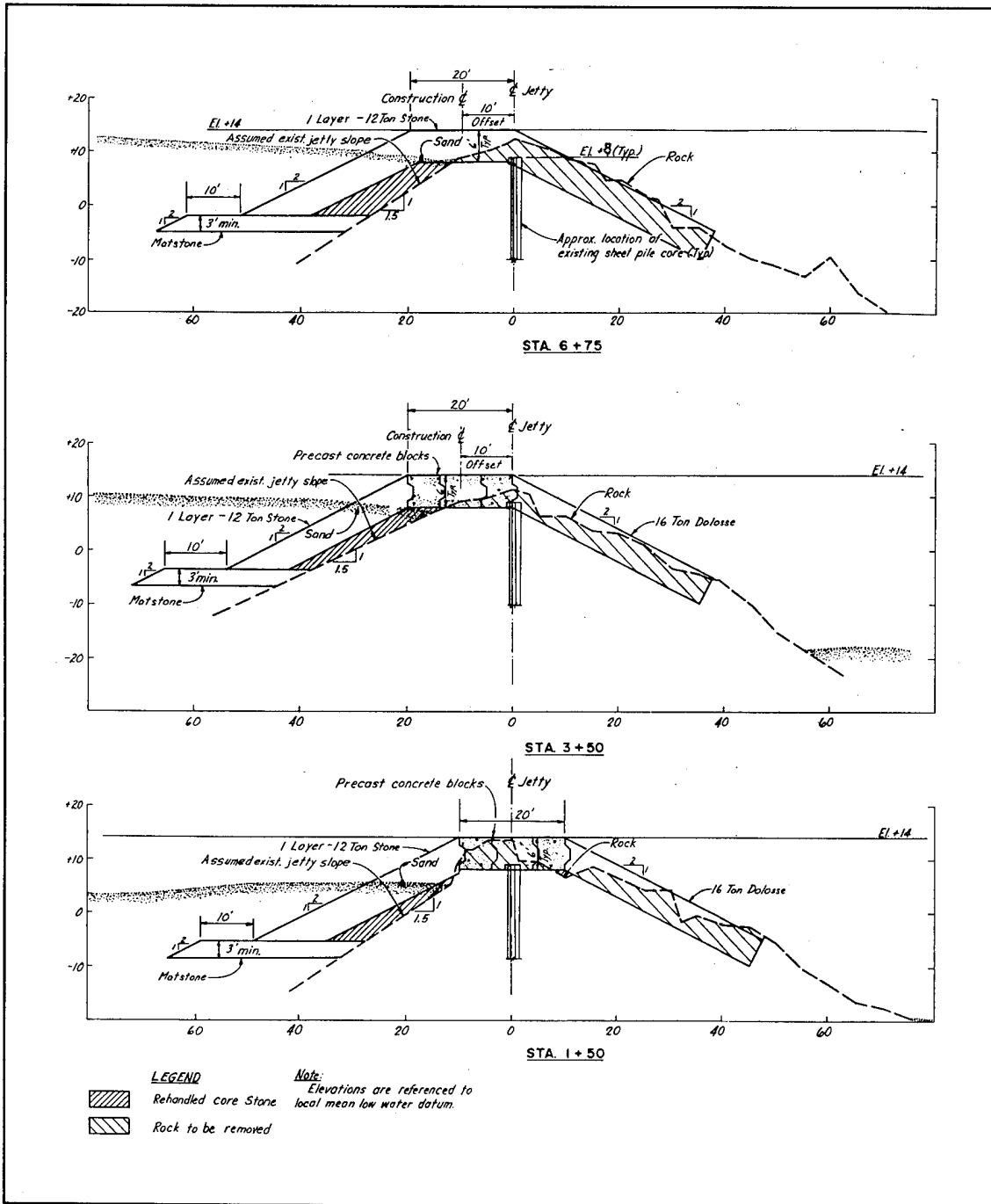

Figure 7. Construction drawings of south jetty cross sections

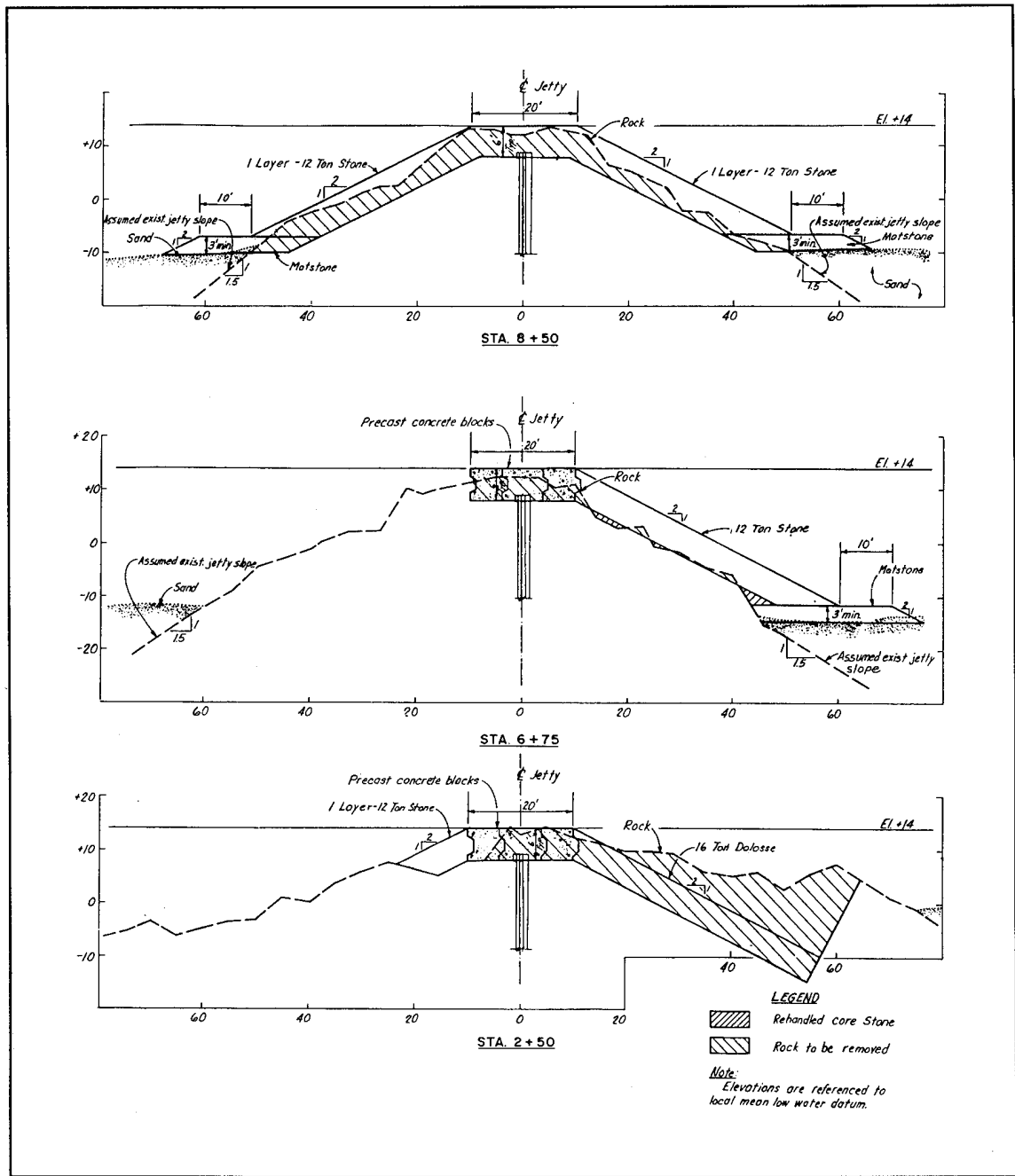

Figure 8. Construction drawings of north jetty cross sections

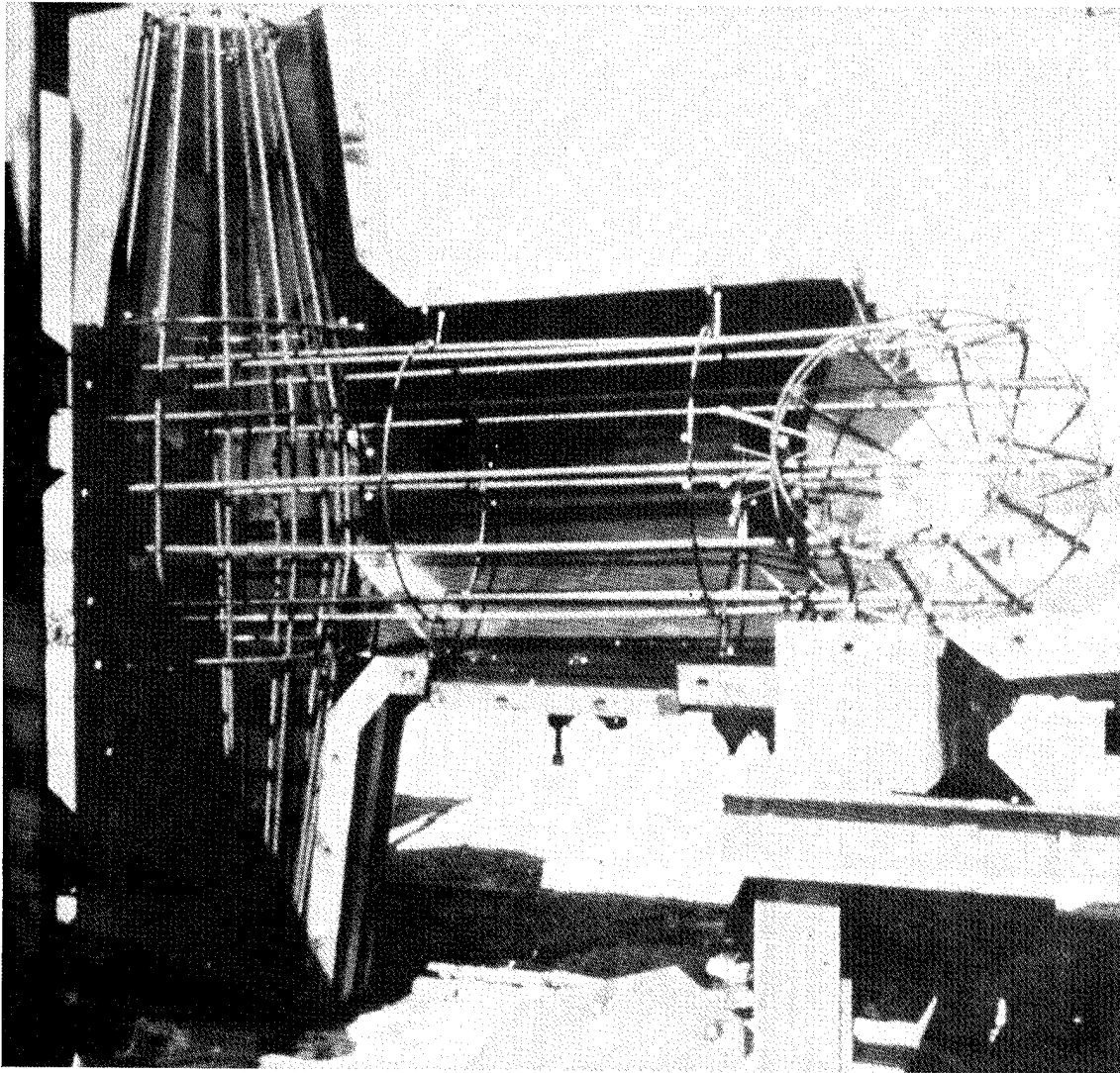

Figure 9. Epoxy-coated, steel reinforcing rods used in dolosse

## **2 Prior Monitoring of the Site**

---

### **Initial (Comprehensive) Monitoring**

#### **General**

The jetty rehabilitation project at Manasquan Inlet was selected for monitoring under the MCCC Program in 1982 during the program's second year. The program has as its goal the advancement of coastal engineering technology. It is designed to determine how well projects are accomplishing their purposes and are resisting the attacks of the physical environment. The primary objective of the Manasquan Inlet jetties rehabilitation monitoring plan was to determine the stability of the jetties, particularly the dolos armor units. This was the first time dolosse were used by the United States in the east coast environment. Additional objectives were to determine potential effects of the rehabilitated jetties on longshore sediment movement at the inlet, and determine the effectiveness of the rehabilitated jetties in maintaining a stable inlet cross section.

Data collection for the monitoring program at Manasquan Inlet occurred from June 1982 to October 1984. The monitoring program incorporated the use of several observational, direct measure, and remote sensing methodologies. It included the collection of wave and tide data, hydrographic and beach surveys, aerial photography, photogrammetric analysis of armor unit movements, broken armor unit surveys, and underwater surveys utilizing side-scan sonar. Results of this study were published in Gebert and Hemsley (1991). Aerial photography, photogrammetric analysis of armor unit movements, and broken armor unit survey data, which are relative to the Periodic Inspections work unit, are summarized below.

#### **Aerial photography**

Aerial photography is a very effective means of capturing images of large areas for later analysis, study, visual comparison to previous or subsequent photography, or measurement and mapping. Its chief attribute is the ability to freeze a moment in time, while capturing great detail.

Black and white aerial photography was obtained from a fixed-wing plane at an altitude of 183 m (600 ft), resulting in a contact scale of 1:1,200. The photography was obtained with a precision cartographic camera, a Zeiss RMK A 15/23. Photographic stereo pairs were obtained during the flights. Aerial photography was obtained for the south jetty on 9 Jan 82, 29 Jan 83, 15 Sep 83, 27 Mar 84, and 9 May 84. For the north jetty, aerial photography was obtained on 29 Jan 83, 15 Sep 83, 27 Mar 84, and 9 May 84. The photography was obtained after significant storm events during the course of the initial Manasquan Inlet monitoring program.

Prior to obtaining aerial photography, primary targets were established on stable portions of the jetties. They were surveyed in from nearby geodetic and vertical control benchmarks and were visible in the aerial photography. The primary targets on the jetties were located along the center lines of the concrete caps.

### **Photogrammetric analysis of armor unit movement**

When aerial photography is planned and conducted so that each photo image overlaps the next by 60 percent or more, the two photographs comprising the overlap area can be positioned under an instrument called a stereoscope, and viewed in extremely sharp three-dimensional detail. If properly selected survey points on the ground have previously been targeted and are visible in the overlapping photography, accurate measurements can be obtained of any point appearing in the photographs. This technique is called photogrammetry.

The stereo pair images obtained during aerial photography at Manasquan Inlet were viewed through a Kern PG 2-AT stereo restitution instrument, and stereo models were oriented to the target data previously obtained. The stereo models were used for compilation and development of plan view outlines of the dolosse and concrete cap. These features were superimposed on a grid based on the New Jersey State Plane Coordinate System, which graphically defined location and orientation of the features in the horizontal plane. Vertical data were recorded numerically at selected points on the dolosse. Photogrammetric maps developed from the stereo models were enlarged 20 times that of the contact scale, to a scale of 1:60.

The photogrammetric maps were plotted on transparent drafting material. The stability of dolosse from one flight to the next was determined by overlaying the two maps and visually comparing the location of individual dolosse. If a dolos moved during the time interval, the horizontal component of movement was evident, as a displacement of the outline occurred which was scaled from the 1:60-scale maps. The vertical component of movement was determined by comparison of spot elevations at particular points.

The initial maps of the north and south jetties were the most detailed prepared during the monitoring program. They documented the location, orientation, and elevation of 754 dolosse, about 57 percent of the 1,326 units placed

on the jetties during the rehabilitation. The remaining 43 percent were not mapped since they were either under water or beneath the top layer of dolosse and not visible in the photography. A portion of the initial south jetty map is shown in Figure 10. Subsequent photogrammetric maps included smaller samples, thus reducing costs of map compilation while still obtaining representative coverage of the armor units on the two jetties.

A comparison of photogrammetry and standard ground-leveling data (ground truthing) for the initial photography suggested that the accuracy of the photogrammetrically derived elevations was on the order of  $\pm 0.09$  m ( $\pm 0.3$  ft). Two factors were identified, however, that could have contributed to these differences. The first was that the time frames between ground truthing and photography differed by as much as 3 months. It was possible that dolos movement could have occurred during these periods, contributing to the apparent differences between photogrammetric and leveling measurements of the same point. The second factor was that there were no visual targets on the dolosse to ensure that the survey crew and the photogrammetrist were observing exactly the same point when measuring an elevation. Features such as "center of face of vertical fluke" were the nominal targets used by the surveyors and photogrammetrist for identifying locations of spot elevations.

Prior to the September 1983 survey, 0.3-m (1.0-ft) black crosses were painted on 111 dolosse distributed over the two jetties, assuring that both the field crew and the photogrammetrist would determine elevations at the same points on the units. Comparisons of the data demonstrated that 84 percent of the photogrammetric values were within  $\pm 0.03$  m ( $\pm 0.1$  ft) of the elevations determined by ground truthing, and 98 percent were within  $\pm 0.06$  m ( $\pm 0.2$  ft). These findings showed that photogrammetry was capable of accurately resolving slight movements of individual armor units that would permit a detailed evaluation of stability.

Ground truthing data were essential in verifying the accuracy of the photogrammetric elevations. However, these data do not provide any information on horizontal displacement, where both elevation and planimetric information are provided by photogrammetry.

As previously discussed, photogrammetric maps prior to September 1983 did not achieve as high a degree of accuracy in measuring dolosse movement as did later maps. However, an analysis of photogrammetric displacement data prior to September 1983 indicated that 65 percent of the observed points were within 0.09 m (0.3 ft) and 91 percent were within 0.3 m (1.0 ft) of their initial elevations. The maximum vertical change detected was a drop of 1.3 m (4.2 ft) on a dolos at the head of the south jetty. Ninety percent of the vertical displacements that exceeded 0.3 m (1.0 ft) occurred on dolosse at the heads of the two structures. The largest horizontal displacement detected was nearly 1.8 m (6.0 ft) on a dolos on the channel side of the south jetty. The next largest horizontal displacement was only 1.1 m (3.5 ft), occurring on the head of the south jetty. The mean horizontal movement of all monitored dolosse prior to September 1983 was about 0.3 m (1.0 ft). The movements were



predominantly rotation with displacement in a downslope direction relative to the structures. Displacement data suggested a relationship between armor unit movement and storm exposure. More movement was noted when storm conditions occurred between surveys as opposed to those during relatively storm-free periods.

All photogrammetric measurements on maps for the period September 1983 through May 1984 used targets (established in September 1983) and were assumed to be of comparable accuracy. The period between 15 September 1983 and 27 March 1984 was relatively storm free, whereas the interval between 28 March and 9 May 1984 was not. Measurements of vertical and horizontal displacements over these two intervals reinforced the earlier findings that dolos movements were predominantly related to storm events.

In the 6-month period from 15 September 1983 to 28 March 1984, the mean vertical displacement for all points monitored on the two jetties was 0.05 m (0.15 ft), and only 10 percent of the monitored dolosse experienced detectable horizontal displacements, the largest of which was about 0.3 m (1.0 ft).

Between 28 and 30 March 1984, an intense coastal storm affected the mid-Atlantic states. The gauge offshore at Manasquan revealed a maximum significant wave height of 6.7 m (22 ft) with a corresponding peak period of about 11.5 sec. The peak of the wave record coincided with the maximum tide stage, and thus exposed the jetties to what is believed to be the equivalent of the design storm. The significant wave height exceeded 6.1 m (20 ft) for 5 hr and 3.0 m (10 ft) for 30 hr.

The mean vertical displacement of all monitored dolosse because of the March 1984 storm was -0.14 m (-0.46 ft). Approximately 3 percent of the dolosse moved in excess of 0.3 m (1.0 ft) vertically, with a maximum value indicating a 0.6-m (2.0-ft) drop. The largest horizontal displacement caused by the storm was 2.1 m (7.0 ft) at the head of the south jetty. There were three other dolosse that moved about 1.5 m (5.0 ft) horizontally. Altogether, only 9 percent of the monitored dolosse moved in excess of 0.6 m (2.0 ft) horizontally, with 31 percent moving up to 0.6 m (2.0 ft). About 60 percent of the dolosse experienced no detectable horizontal movement.

### **Broken armor units**

As a result of the March 1984 storm, three dolosse broke on the north jetty, all within a zone about 10.7 m (35 ft) wide at the head of the structure. Two of the breaks resulted in loss of some concrete from the shank portions of the dolosse, but the presence of the epoxy-coated reinforcing steel kept the dolosse substantially intact. One of these dolos sustained significant damage, with considerable loss of concrete and reinforcing steel exposed in the break. Another dolos on the north jetty suffered a hairline crack through one fluke. As a result of the storm, one south jetty dolos, located near the head of the

channel side of the structure, broke at the junction of the shank and fluke. This dolos was still intact because of the reinforcing steel.

Prior to the March 1984 storm, one other dolos at the head of the north jetty had broken. Despite exposure to the design storm wave event, only 5 of the 1,326 dolosse (only 0.4 percent) used in the 1979-1982 rehabilitation had broken. It should be noted that of the five broken units, only one had experienced a net horizontal displacement in excess of 0.6 m (2.0 ft) from its initial location. Other dolosse had moved greater distances, up to 2.1 m (7.0 ft) between successive photography, yet had not broken. This finding suggested that movement alone may not be responsible for armor unit breakage. Impact may be more important than movement in dolos breakage. An armor unit may experience significant impacts even with only small movements.

Typical reasons for dolos breakage often include the following (a) stress patterns within the original cast dolosse, (b) handling and placement, (c) settling of the structure, stressing units within the breakwater, (d) wave-induced displacement, (e) wave-induced rocking and fatigue failure, (f) ice pressure and movement, and (g) impact from debris, other dolos, and dolos fragments.

### **Conclusions from Initial dolos monitoring**

Conclusions, drawn relative to the initial in-depth armor unit monitoring effort for the Manasquan Inlet jetties (Gebert and Hemsley 1991) were as follows:

- a. Even though the Manasquan Inlet, NJ, jetties have experienced a near-design storm, they have continued to perform successfully and have not required even the low level of maintenance anticipated by the designers. This overall excellent performance of the jetties and, in particular, the low percentage of broken dolosse during the March 1984 storm serve to verify the design and construction procedures used in the rehabilitation.
- b. One of the particular successes of the monitoring effort was the application of photogrammetric mapping to surveying the structural condition of coastal structures. While it has been applied to dolosse in this study, it is equally applicable to structures with any type of natural or man-made armor.
- c. The use of photogrammetric mapping of the jetties allowed a detailed evaluation of the motion of the armor units. This technique was found to be cost-effective and accurate, providing accuracy comparable with standard ground-truthing techniques.
- d. Photogrammetry offers several advantages over conventional land surveying techniques. First, it is possible to map armor units at or near the waterline of the structure, units that would be inaccessible or too hazardous to reach on foot. Second, photogrammetry is flexible in that all the information needed to perform the mapping can be obtained

almost instantaneously, permanently, and at fixed cost with one aerial photographic flight. Another advantage is that the product is graphical. It is, therefore, more readily interpreted with respect to location and magnitude of armor unit displacements.

- e. It is apparent that the dolosse at Manasquan Inlet have benefitted from the use of steel reinforcement. Even those units that have cracked have been kept whole by their reinforcement. The steel reinforced dolosse exhibited a degree of mobility on the jetty face in response to storm conditions and did not incur significant damage.
- f. Despite the relatively short duration of monitoring, measurements have shown that the jetties have experienced a near-design storm. Photogrammetric measurements document that the dolosse do move on these jetties, especially in response to storm exposure. These measurements have quantitatively shown which dolosse have moved, how far, and in which direction. However, there is no indication that the range of dolosse displacements experienced to date has in any way compromised the effectiveness of the rehabilitation. The photogrammetric measurements have also shown that none of the monitored dolosse have experienced a displacement, either horizontal or vertical, in excess of about 65 percent of the unit dimension of 3.4 m (11 ft).

## **Subsequent Armor Unit Monitoring**

Subsequent to the original monitoring effort of the dolosse at Manasquan Inlet through the MCCP Program, an additional photogrammetric survey was conducted in 1992 using funds provided by the USAED, Philadelphia.

Monuments used in the May 1984 survey were reestablished through ground surveys, and aerial photography was obtained during June 1992 from a fixed-wing aircraft at an altitude of 183 m (600 ft). Stereo pair images obtained were viewed in a stereoscope and photogrammetric maps at a scale of 1:60 were produced. The stereo model was oriented to the reestablished monument data, and vertical and horizontal positions of the targeted dolosse (those targeted in 1983 with black crosses) were obtained. The data obtained for the targets were compared to data obtained at the end of the original monitoring program in May 1984.

A detailed analysis of the changes between the June 1992 and May 1984 data was not conducted due to the nonavailability of time and funds in the Philadelphia District. Of the targeted dolosse monitored, it was determined that random horizontal displacements ranging from 0.15 to 1.5 m (0.5 to 5.0 ft) occurred on both the north and south jetties. In general, vertical displacements indicated settlement up to 0.15 m (0.5 ft) on both jetties. The largest displacements on both jetties occurred at their heads. A more detailed analysis of these (1992) data is included in Chapter 3 of this report.

## 3 Current Monitoring Plan and Data Comparison

---

The objective of the monitoring effort in the Periodic Inspections work unit was to reexamine the dolosse portions of the Manasquan Inlet jetties and determine changes that have occurred since the MCCP Program ended in 1984. The monitoring plan consisted of targeting and ground surveys, low-altitude aerial photography, photogrammetric analysis of armor unit locations, a broken armor unit survey, and comparisons of current armor unit positions with those obtained previously.

### Targeting and Ground Surveys

Monuments used previously were reestablished on the caps of the jetties to serve as control points (both horizontal and vertical reference) for ground-based survey work as well as photogrammetric work. Ground surveys were initiated from known monuments on shore. Using global positioning system control surveying and electronic land surveying techniques, monument positions were resurveyed in August 1994. Monument locations on the jetty caps are shown in Figure 11, and a typical monument is shown in Figure 12. Monuments used were brass disks cemented into the jetty cap. Positions and elevations of the most recently established monuments are shown in Table 1. Horizontal positions are based on the New Jersey State Plane Coordinate System and all elevations are referenced to mean low water.

Horizontal and vertical position data obtained on monuments established during the September 1992 survey and the May 1984 survey are shown in Table 2. Note that monuments MS-3 and MS-4 on the south jetty cap for the 1984 survey were unrecoverable and were replaced with monuments MS-3A and MS-4A for the 1992 survey.

Differences, where applicable, between the horizontal and vertical positions of the monuments established on the jetty caps are shown in Table 3 for the 1984, 1992, and 1994 surveys.

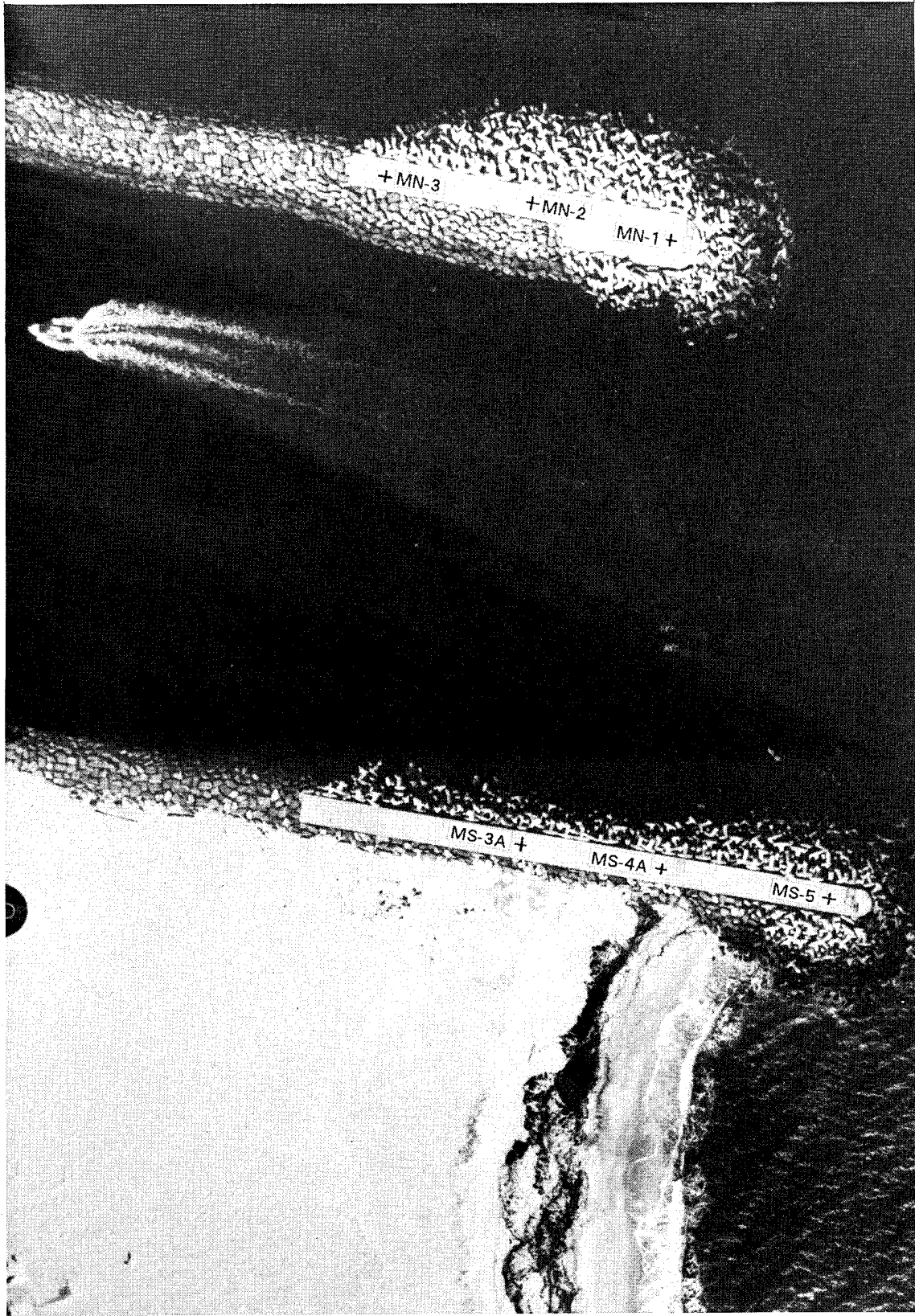

Figure 11. Locations of monuments on jetty caps

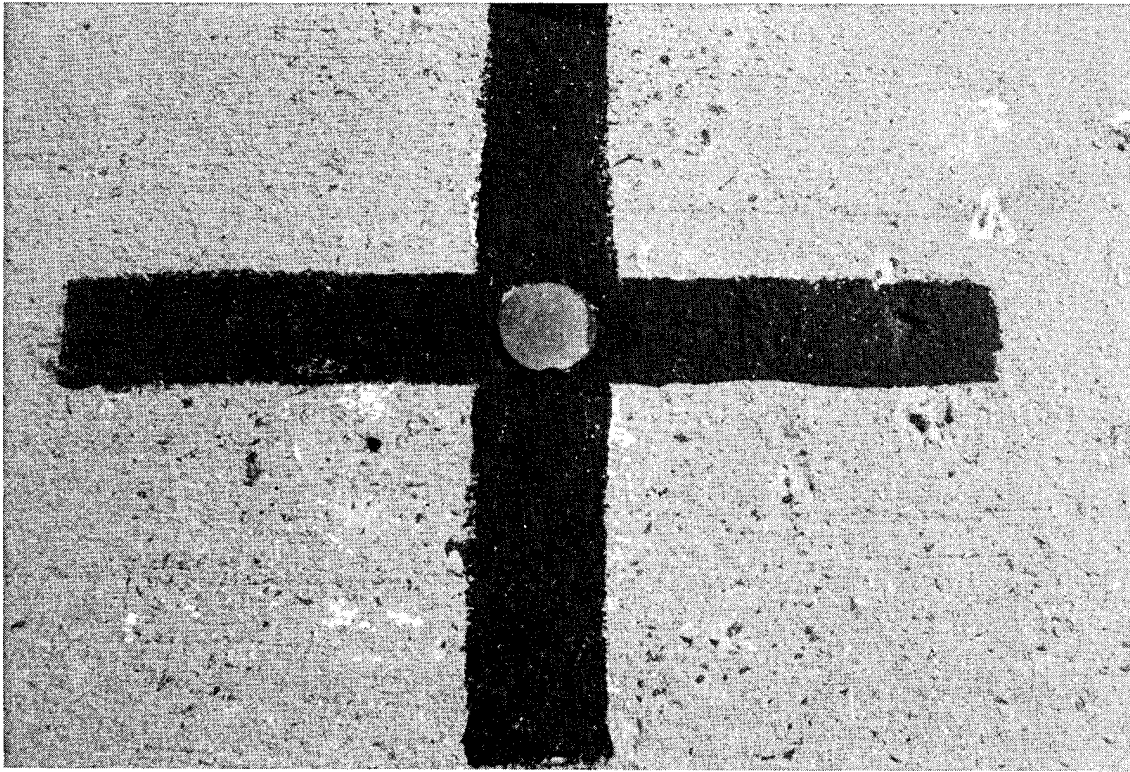

Figure 12. Example of a monument established on jetty cap

<b>Table 1</b>			
<b>Positions and Elevations of Monuments</b>			
	<b>1994 Coordinates</b>		
<b>Monument</b>	<b>Northing</b>	<b>Easting</b>	<b>1994 El, m (ft)</b>
<b>North Jetty Cap</b>			
MN-1	N462562.20	E2177592.77	+4.27 (+14.0)
MN-2	N462623.88	E2177516.50	+4.22 (+13.85)
MN-3	N462680.17	E2177433.89	+4.26 (+13.99)
<b>South Jetty Cap</b>			
MS-3A	N462232.84	E2177320.33	+4.25 (+13.95)
MS-4A	N462176.24	E2177403.29	+4.24 (+13.91)
MS-5	N462107.30	E2177503.96	+4.26 (+13.99)

As shown from the data in Table 3, horizontal shifts of the monuments on the concrete jetty caps have ranged from .003 to .03 m (.01 to 0.1 ft) since the initial monitoring program ended in 1984. Examination of 1992 and 1994 survey data reveals horizontal movements ranging from 0.0 to .015 m (0.0 to .05 ft). The data also indicate a slight subsidence or settlement of the jetty caps since the initial monitoring program ended in 1984. From 1984 to 1994,

<b>Table 2</b>			
<b>Position Data Obtained During 1992 and 1984 Surveys</b>			
<b>1992 Coordinates</b>			
<b>Monument</b>	<b>Northing</b>	<b>Easting</b>	<b>1992 El, m (ft)</b>
<b>North Jetty Cap</b>			
MN-1	N462562.17	E2177592.74	+4.27 (+14.01)
MN-2	N462623.83	E2177516.48	+4.22 (+13.86)
MN-3	N462680.13	E2177433.92	+4.27 (+14.0)
<b>South Jetty Cap</b>			
MS-3A	N462232.89	E2177320.32	+4.26 (+13.97)
MS-4A	N462176.24	E2177403.27	+4.25 (+13.94)
MS-5	N462107.33	E2177503.95	+4.27 (+14.02)
<b>1984 Coordinates</b>			
<b>Monument</b>	<b>Northing</b>	<b>Easting</b>	<b>1984 El, m (ft)</b>
<b>North Jetty Cap</b>			
MN-1	N462562.22	E2177592.67	+4.31 (+14.13)
MN-2	N462623.87	E2177516.43	+4.26 (+13.97)
MN-3	N462680.09	E2177433.88	+4.30 (+14.11)
<b>South Jetty Cap</b>			
MS-3	N462264.85	E2177275.05	+4.29 (+14.07)
MS-4	N462187.51	E2177386.74	+4.29 (+14.09)
MS-5	N462107.34	E2177503.92	+4.31 (+14.15)

data reveal the monuments had subsided from 0.037 to 0.049 m (0.12 to 0.16 ft). From 1992 to 1994, however, the settlement of the jetty caps ranged from only 0.003 to 0.009 m (0.01 to 0.03 ft).

In addition to the monuments, targets were reestablished on the dolosse that corresponded with those established prior to the 1984 survey. A total of 111 dolosse, distributed over the two jetties, were initially targeted with 0.3-m (1.0-ft) painted black crosses to ensure visibility in the aerial photography. Of these, 60 targets were established on the south jetty and 51 targets on the north jetty. For the current (1994) survey, 57 of the original 60 targets on the south jetty and 45 of the original 51 targets on the north jetty were recovered and reestablished with the 0.3-m (1.0-ft) black crosses. Some of the unrecovered targets were on armor units located at the water's edge, and could not be reestablished during ground surveys due to the slippery algae growing on the dolosse. Others were inadvertently missed. The actual locations of the targeted dolosse distributed over the north and south jetties are shown in Figures 13 and 14. Numbers correspond to the originally established targets. In addition to the painted black crosses, the center of each target was marked with a drill hole 0.64 cm (1/4 in.) in diameter and 0.64 cm (1/4 in.) deep to aid in identifying targeted units in subsequent surveys. A typical target established on a dolos is shown in Figure 15.

<b>Table 3</b>			
<b>Differences Between Horizontal and Vertical Positions of Monuments</b>			
<b>Monument</b>	<b>Northing</b>	<b>Easting</b>	<b>Elevation</b>
Difference from 1984 to 1992, m (ft)			
MN-1	.015 (.05)	.021 (.07)	-.037 (-.12)
MN-2	.012 (.04)	.015 (.05)	-.034 (-.11)
MN-3	.012 (.04)	.012 (.04)	-.034 (-.11)
MS-3A	N/A	N/A	N/A
MS-4A	N/A	N/A	N/A
MS-5	.003 (.01)	.009 (.03)	-.040 (-.13)
Difference from 1992 to 1994, m (ft)			
MN-1	.009 (.03)	.009 (.03)	-.003 (-.01)
MN-2	.015 (.05)	.006 (.02)	-.003 (-.01)
MN-3	.012 (.04)	.009 (.03)	-.003 (-.01)
MS-3A	.015 (.05)	.003 (.01)	-.006 (-.02)
MS-4A	0 (0)	.006 (.02)	-.009 (-.03)
MS-5	.009 (.03)	.003 (.01)	-.009 (-.03)
Difference from 1984 to 1994, m (ft)			
MN-1	.006 (.02)	.030 (.10)	-.040 (-.13)
MN-2	.003 (.01)	.021 (.07)	-.037 (-.12)
MN-3	.024 (.08)	.003 (.01)	-.037 (-.12)
MS-3A	N/A	N/A	N/A
MS-4A	N/A	N/A	N/A
MS-5	.012 (.04)	.012 (.04)	-.049 (-.16)

## Aerial Photography

Aerial photography was obtained on the jetties with a Wild RC30 aerial mapping camera (9-in. by 9-in. format). The photos were secured from a fixed-wing aircraft flying at low altitude (183 m (600 ft)), which resulted in high-resolution images and contact prints with scales of 1:1,200. Photographic stereo pairs for the jetties obtained during the flights are shown in Figures 16-18. The seaward photo image (Figure 16) was used with the middle image (Figure 17), and the landward image (Figure 18) was used with the middle image (Figure 17) in the stereo viewer to develop stereo models. Aerial photography was obtained on 6 August 1994.

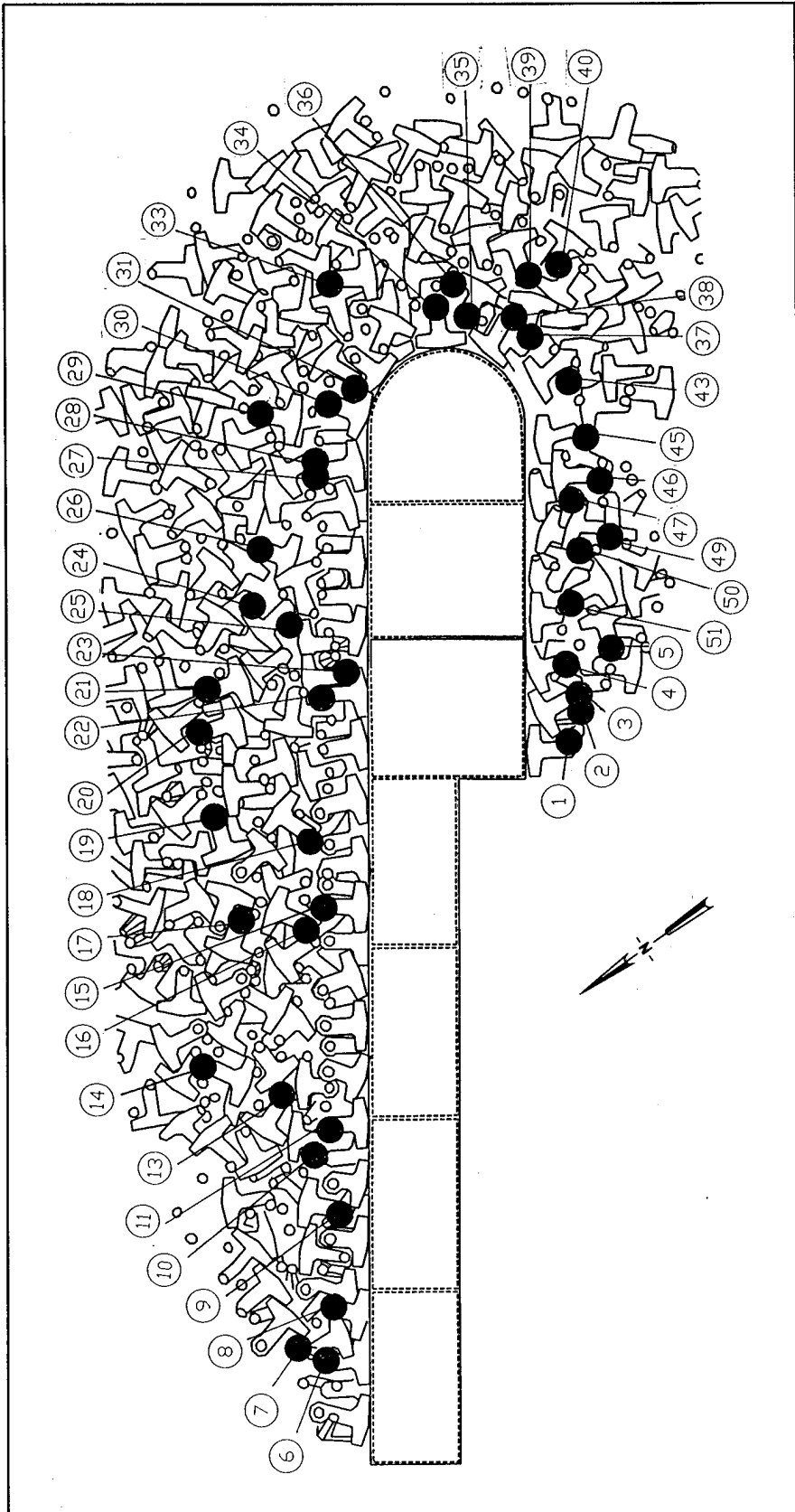

Figure 13. Locations of targeted dolosse on north jetty

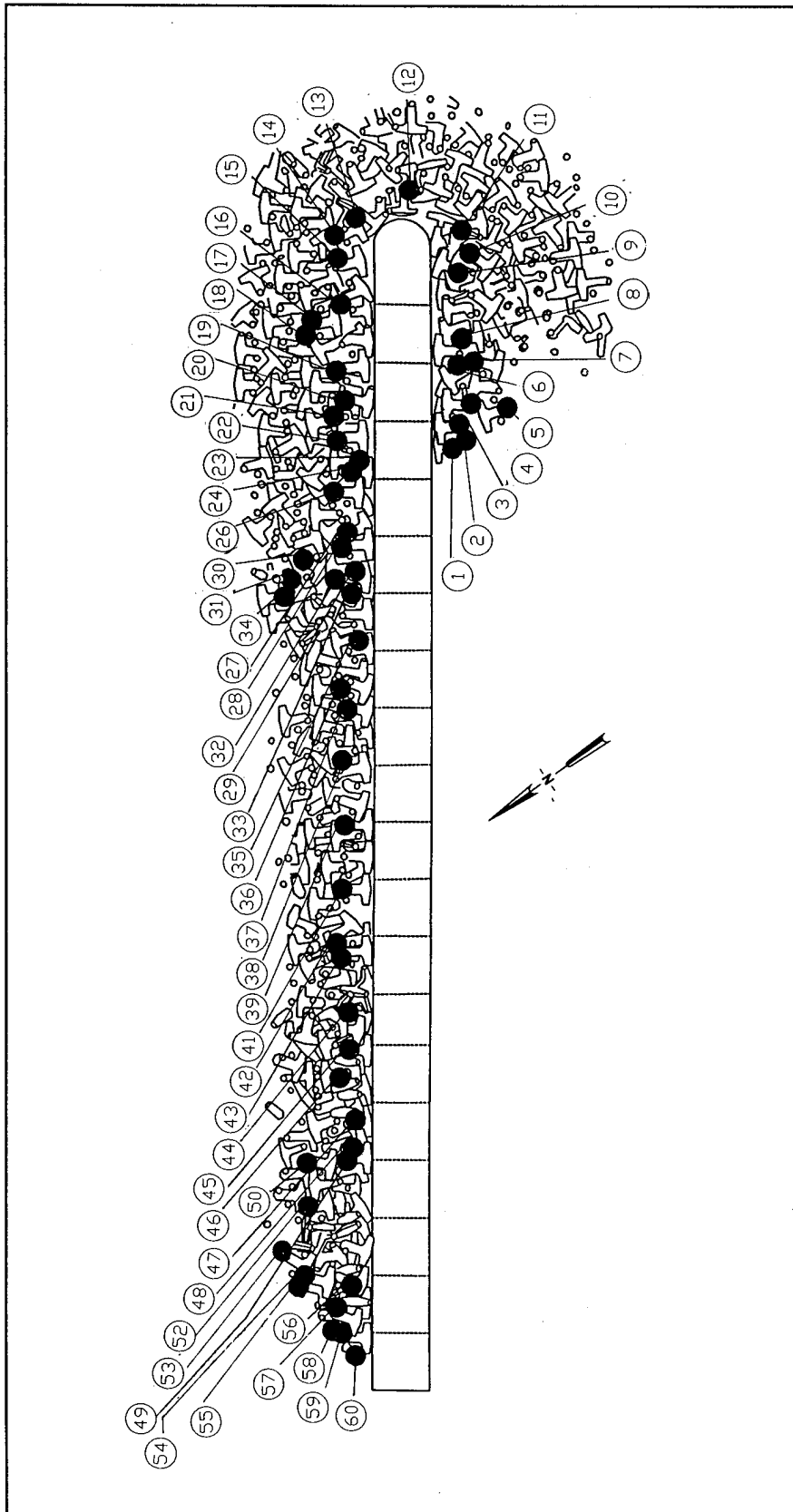

Figure 14. Locations of targeted dolosse on south jetty



Figure 15. Typical target established on a dolos armor unit

## Photogrammetric Analysis of Armor Units

The stereo pair images obtained during aerial photography at Manasquan Inlet were viewed in a Zeiss P3 Planicomp Analytical Stereo Plotter, and stereo models were oriented to the monument data previously obtained. In the stereo model, very accurate horizontal and vertical measurements can be made of any point on any armor unit appearing in the print. After orientation of the stereo model with monument data, x, y, and z coordinates were determined for the 102 established targets. As indicated earlier, the accuracy of this technique was on the order of  $\pm 0.03$  m ( $\pm 0.1$  ft) for the majority of the units. In addition to the data obtained on the targets, additional horizontal and vertical position data were obtained at other points on various dolosse through the stereo model. Without a visual target, the accuracy of these analyses was on the order of  $\pm 0.09$  m ( $\pm 0.3$  ft). Analyses and comparisons of armor unit movement data from the 1984, 1992, and 1994 photogrammetric surveys are presented later in this part of the report.

Photogrammetric maps were developed from the stereo models, similar to those done in earlier surveys. Tracings of plan view outlines of the visible dolosse as well as vertical data at various points were plotted at a scale of 1:60, or 20 times that of the stereo pair contact scale. In addition, rectified photographs (orthophotos) of the jetties were prepared from the stereo model at



Figure 16. Stereo pair photograph for Manasquan Inlet jetties (seaward photo image)

a scale of 1:300. Orthophotos combine the image characteristics of a photograph with the geometric qualities of a map. Precise horizontal measurements may be obtained from the orthophotos using an engineer scale since the image has been rectified and is free from skewness and distortion.

Full-scale hard copies of aerial photographs, photogrammetric maps, and orthophotos are on file at the authors' offices at the U.S. Army Engineer Waterways Experiment Station (WES) and CENAP. In addition, all photogrammetric compilations and analysis and map data have been stored on diskettes in AutoCad files for future use. In summary, very detailed and accurate information relative to the armor unit positions at the Manasquan Inlet jetties has been captured by means of aerial photography and photogrammetric

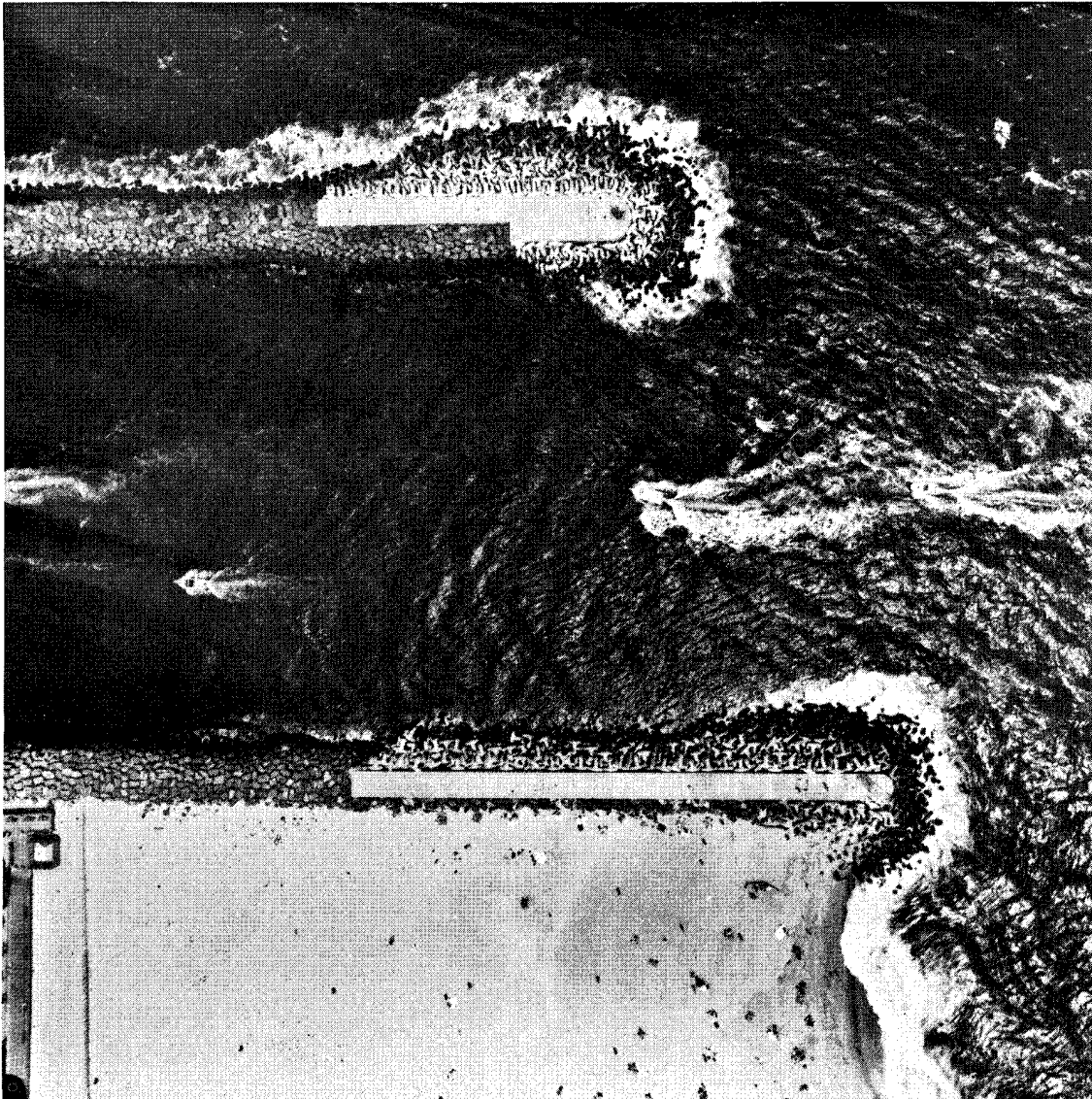

Figure 17. Stereo pair photograph for Manasquan Inlet jetties (middle photo image)

analysis. Data are stored on diskettes and can be retrieved and compared against data obtained during subsequent monitoring. Thus, armor unit movement data may continue to be quantified precisely in future years.

## Broken Armor Unit Survey

On 15 November 1994, a survey of broken/cracked dolosse armor units above the waterline on the Manasquan Inlet jetties was conducted. During the inspection, each broken armor unit was identified and photographed, and its approximate location relative to breakwater station and offset from the concrete

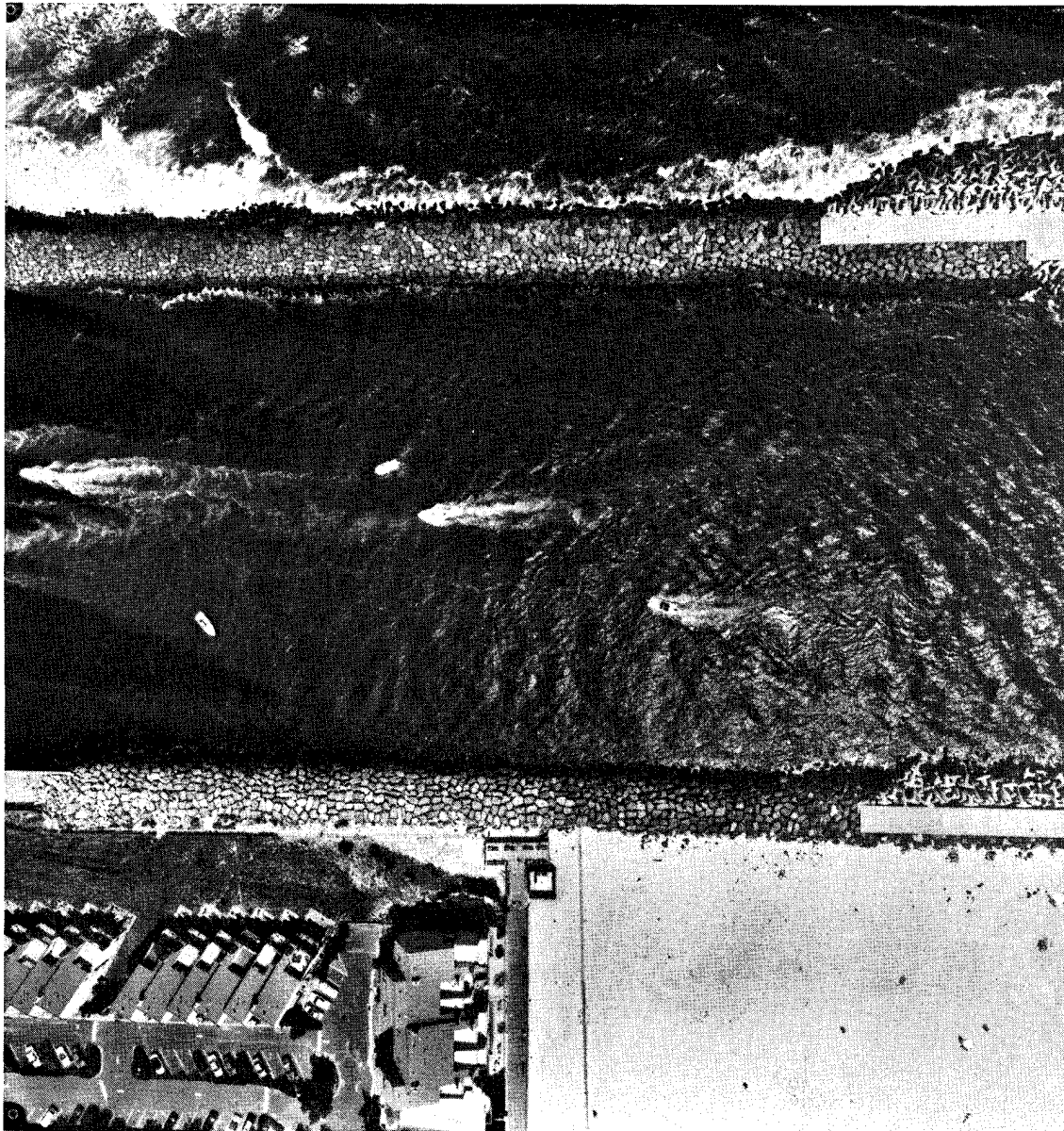

Figure 18. Stereo pair photograph for Manasquan Inlet jetties (landward photo image)

jetty cap was recorded. In addition, the dolosse number and date of casting, if visible, as well as the type of break and break separation distance (approximate distance separating dolos segments) were recorded. Types of breaks included shank and fluke breaks. They were characterized as mid-shank, shank-fluke (shank broken in vicinity of fluke), and fluke-shank (fluke broken off at junction with shank). Also recorded were straight breaks (broken straight across) and angled breaks (broken some angle to the dolos limb). Views of representative types of breaks on dolosse at Manasquan Inlet are shown in Figures 19-22. The water was relatively clear during the survey, and the tide level was low. Some of the data recorded, as a result of the broken armor unit inventory, are shown in Table 4.



Figure 19. Dolos on south jetty with shank/fluke break



Figure 20. Dolos on south jetty with shank-fluke crack

Of the 17 broken/cracked armor units observed, 8 were located on the south jetty and 9 were situated on the north jetty. The distribution of these broken/cracked dolosse on the jetties is shown in Figures 23 and 24. One unit had two separate breaks. Pieces of the armor units were separated on



Figure 21. Dolosse on north jetty with shank-fluke breaks

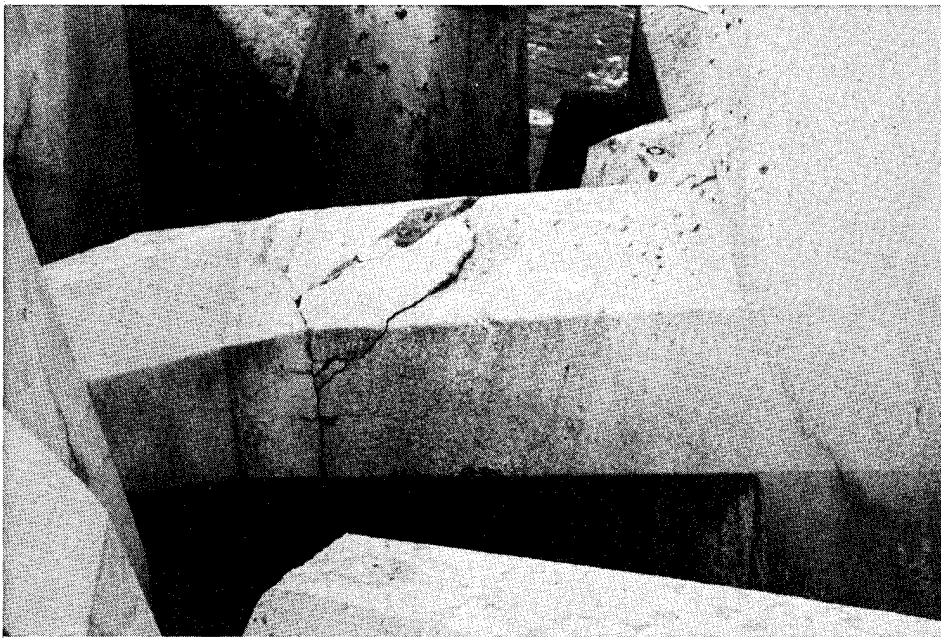

Figure 22. Dolos on north jetty with mid-shank crack

10 dolosse. Four of the dolosse were broken/cracked and being held together by rebar, and four armor units had only hairline cracks.

Considering the types of breaks, the majority (11) were shank-fluke breaks. There were five mid-shank breaks and two fluke-shank breaks. There were ten

<b>Table 4 Broken Armor Unit Survey</b>				
<b>Unit No.</b>	<b>Offset from Jetty Cap, m (ft)</b>	<b>Type of Break</b>	<b>Break Separation Distance, m (ft)</b>	<b>Comments</b>
South Jetty				
1	1.2 (4)	Angled mid-shank	2.1 (7)	Separated, core stone exposed
2	5.5 (18)	Angled mid-shank	0.3 (1)	Separated, but touching
3	1.1 (3.5)	Straight shank-fluke	0	Cracked through
4	9.7 (32)	Angled shank-fluke	1.2 (4)	Separated
5	11.6 (38)	Straight shank-fluke	1.8 (6)	Separated
6	11.0 (36)	Angled mid-shank	1.2 (4)	Separated
7	10.1 (33)	Straight shank-fluke	Unknown	Fluke only
8	1.5 (5)	Angled shank-fluke	0	Cracked through
North Jetty				
9	14.3 (47)	Angled shank-fluke	0	Separated, but touching
10	11.9 (39)	Angled shank-fluke	0	Separated, but touching
11	7.6 (25)	Straight shank-fluke angled fluke-shank	1.5 (5)	Two breaks, separated cracked through
12	7.0 (23)	Straight mid-shank	3.7 (12)	Smaller piece seaward of main unit
13	5.2 (17)	Angled shank-fluke	0	Hairline crack
14	7.9 (26)	Angled mid-shank	0	Hairline crack
15	1.5 (5)	Straight shank-fluke	0	Hairline crack
16	1.8 (6)	Straight fluke-shank	0	Hairline crack
17	9.1 (30)	Straight shank-fluke	0	Cracked through

angled breaks and eight straight ones. Comparison of breakage to production data showed that no production group had an unusual amount of breakage. The distribution of broken/cracked dolosse indicates that 15 of the 17 units were concentrated around the jetties' seaward heads, as shown in Figures 23 and 24. In addition, most of the broken/cracked armor units were found in the active wave zone.

Overall, the rate of dolosse breakage since the rehabilitation has been limited. With 17 broken/cracked units of the 1,326 dolosse placed (assuming no breakage under water), the breakage rate is only 1.3 percent. The only area of concern noted during the broken armor unit survey was at the tip of the south jetty. A broken armor unit in this location had left the core stone under the jetty cap exposed (Figure 25). Subsequent to the survey, nylon bags were placed in this area (at the tip of the south jetty), and concrete was pumped into them as a temporary solution. A total of about 53.5 cu m (70 cu yd) of concrete was used. Up to this point, no maintenance had been performed on the jetties since the rehabilitation was completed in 1982. Overall, it appears the

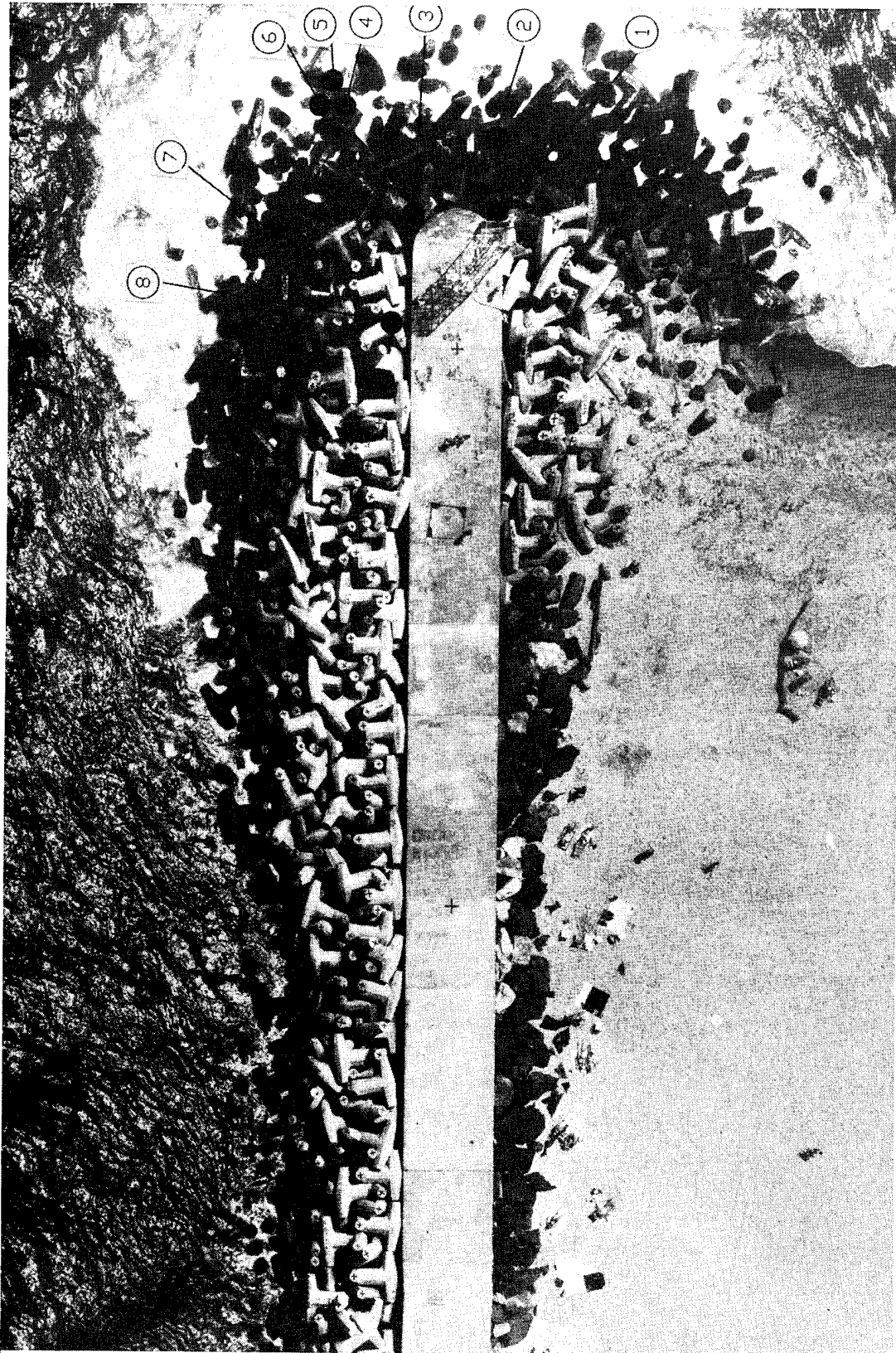

Figure 23. Approximate locations of broken/cracked dolos armor units on south jetty

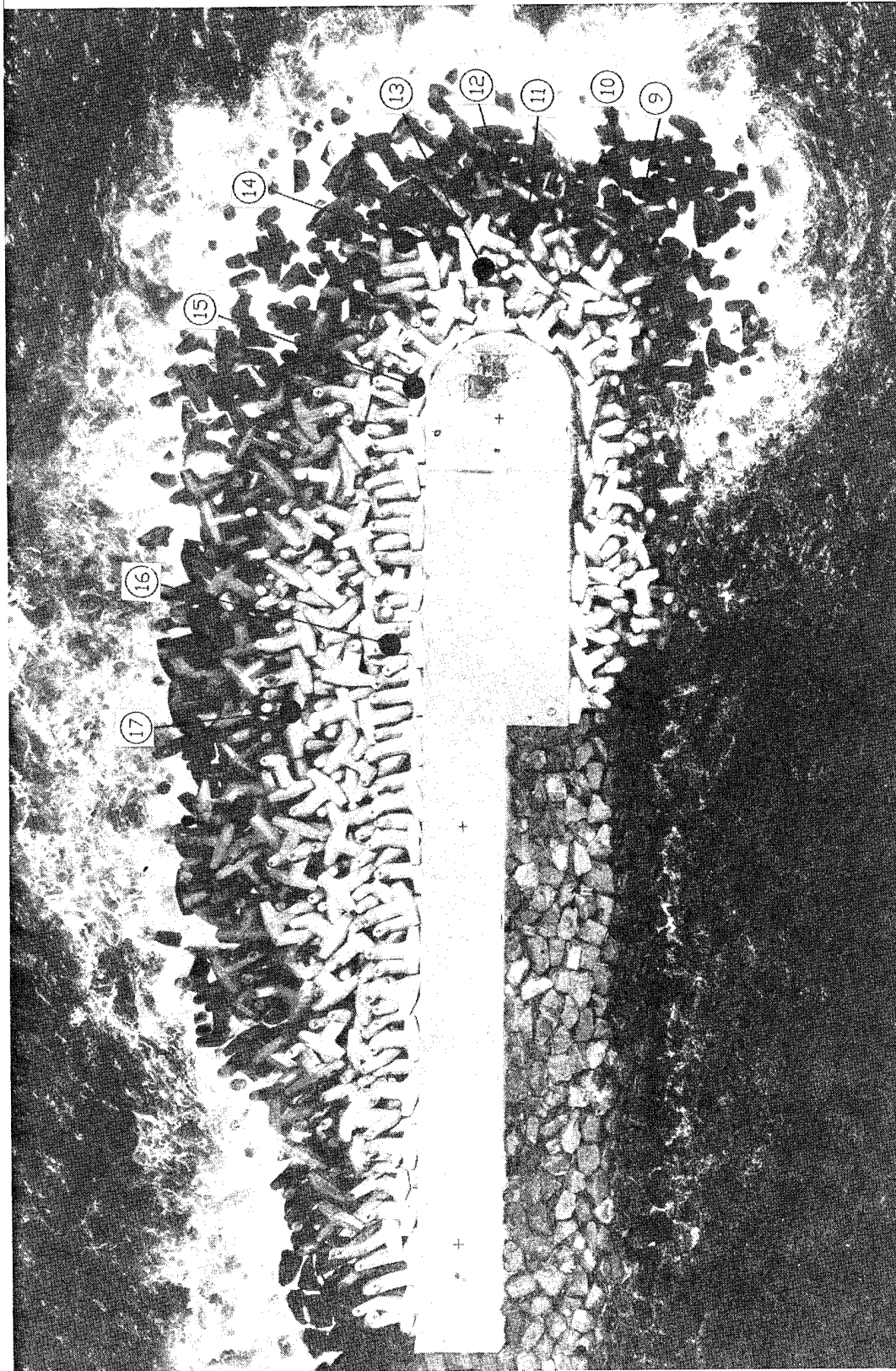

Figure 24. Approximate locations of broken/cracked dolos armor units on north jetty

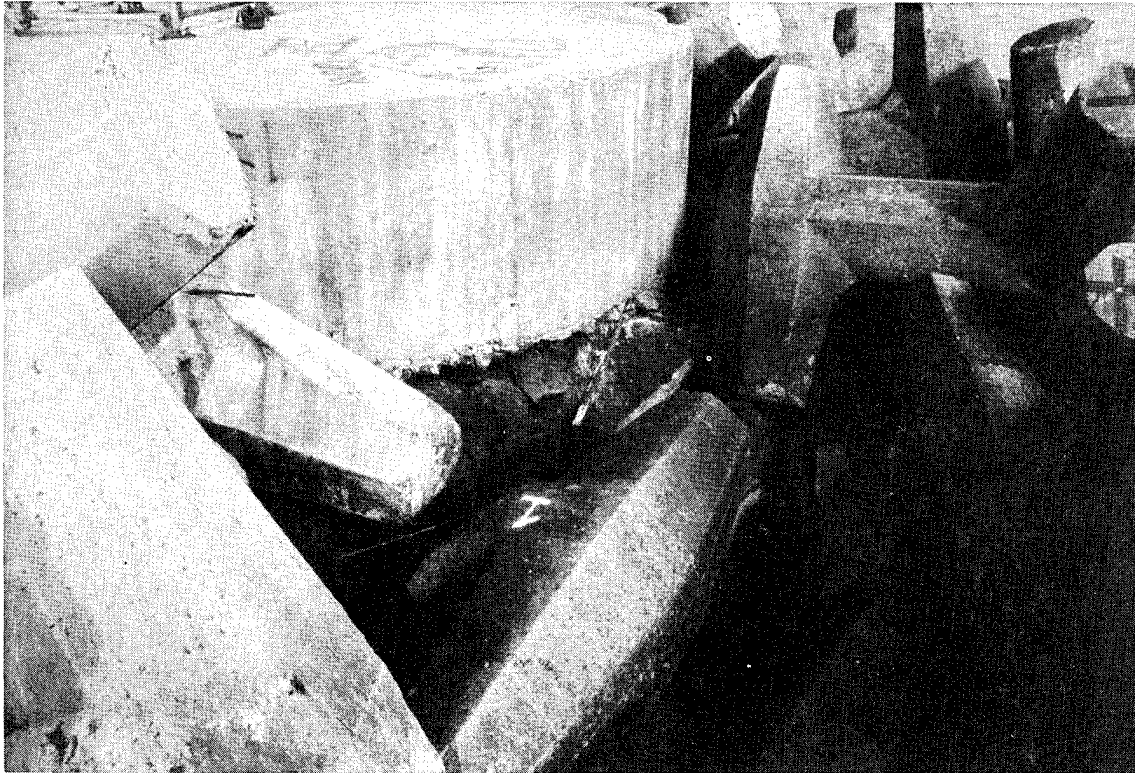

Figure 25. Core stone exposed at head of south jetty due to broken armor units

jetties are in good structural condition and are functioning as intended. The detailed data obtained during the current survey (1994) will allow for an accurate indication of new breakage when the structure is revisited at some point in the future.

## Comparison of Armor Unit Movement Data

Initially, the horizontal and vertical positions of the 102 targeted dolosse distributed along the north and south jetties were evaluated for the 1994, 1992, and 1984 photogrammetric surveys. Horizontal positions and elevations of the targets, obtained from the stereo models, are shown in Table 5 for the three photogrammetric surveys. Horizontal data are based on the New Jersey State Plane Coordinate System and elevations are referenced to mean low water.

Displacements between the horizontal and vertical positions of the targets established on the north and south jetties are shown in Table 6 for the 1984, 1992, and 1994 surveys.

**Table 5  
Data from 1994, 1992, and 1984 Photogrammetric Surveys**

1994 Survey			
Target	Easting	Northing	Elevation, m (ft)
North Jetty			
1	2177524.06	462578.70	5.87 (19.25)
2	2177527.78	462571.58	4.15 (13.62)
3	2177531.16	462569.54	4.36 (14.32)
4	2177537.60	462568.24	5.99 (19.66)
5	2177535.33	462558.13	4.22 (13.84)
6	2177442.80	462698.08	4.82 (15.82)
7	2177448.16	462700.93	4.11 (13.49)
8	2177451.38	462689.58	5.91 (19.38)
9	2177467.43	462677.13	5.96 (19.56)
10	2177481.04	462673.64	5.60 (18.38)
11	2177483.64	462668.58	6.00 (19.67)
13	2177496.00	462672.88	4.51 (14.80)
14	2177510.46	462683.86	3.77 (12.37)
15	2177524.66	462643.13	5.03 (16.50)
16	2177523.04	462647.83	4.71 (15.46)
17	2177532.70	462659.08	4.80 (15.74)
18	2177538.26	462636.86	4.02 (13.19)
19	2177554.74	462651.20	4.48 (14.71)
20	2177571.44	462643.60	4.51 (14.80)
21	2177578.28	462637.13	5.09 (16.70)
22	2177562.50	462616.48	5.01 (16.45)
23	2177564.00	462609.33	5.07 (16.64)
24	2177586.38	462632.96	4.28 (14.05)
25	2177582.38	462611.84	5.34 (17.52)
26	2177597.16	462609.50	4.67 (15.31)
27	2177603.54	462590.18	4.79 (15.70)
28	2177607.23	462588.38	5.09 (16.70)
29	2177620.58	462593.14	4.90 (16.07)

(Sheet 1 of 11)

<b>Table 5 (Continued)</b>			
<b>1994 Survey (Continued)</b>			
<b>Target</b>	<b>Easting</b>	<b>Northing</b>	<b>Elevation, m (ft)</b>
North Jetty (Continued)			
30	2177614.70	462579.84	5.65 (18.55)
31	2177613.70	462573.08	4.85 (15.92)
33	2177635.54	462564.56	4.43 (14.52)
34	2177618.44	462548.40	5.23 (17.17)
35	2177612.56	462544.03	5.29 (17.37)
36	2177622.38	462540.56	4.43 (14.52)
37	2177603.24	462534.58	5.01 (16.44)
38	2177606.38	462534.78	3.90 (12.78)
39	2177612.16	462529.16	4.12 (13.53)
40	2177610.53	462520.30	3.96 (12.99)
43	2177587.70	462532.43	4.52 (14.84)
45	2177576.36	462536.56	3.56 (11.68)
46	2177568.14	462538.58	4.19 (13.76)
47	2177567.04	462546.68	4.40 (14.45)
49	2177554.86	462544.14	3.35 (10.99)
50	2177556.26	462551.64	4.22 (13.86)
51	2177549.04	462559.94	3.97 (13.01)
South Jetty			
1	2177453.30	462120.83	5.03 (16.51)
2	2177453.51	462114.76	4.74 (15.55)
3	2177457.86	462113.99	5.21 (17.08)
4	2177462.66	462106.60	4.96 (16.26)
5	2177453.84	462096.59	3.56 (11.68)
6	2177477.66	462103.16	4.92 (16.14)
7	2177473.34	462097.89	4.31 (14.14)
8	2177481.94	462097.19	5.32 (17.45)
9	2177501.76	462083.61	4.50 (14.77)
10	2177505.74	462077.81	4.24 (13.91)
11	2177513.91	462075.31	4.35 (14.28)
12	2177535.21	462081.34	4.09 (13.43)
(Sheet 2 of 11)			

**Table 5 (Continued)****1994 Survey (Continued)**

<b>Target</b>	<b>Easting</b>	<b>Northing</b>	<b>Elevation, m (ft)</b>
<b>South Jetty (Continued)</b>			
13	2177538.44	462103.69	4.56 (14.95)
14	2177537.24	462112.84	4.01 (13.15)
15	2177530.90	462116.60	4.54 (14.89)
16	2177515.36	462124.84	4.29 (14.08)
17	2177516.01	462137.64	3.91 (12.84)
18	2177514.44	462139.91	4.64 (15.23)
19	2177498.40	462138.60	4.48 (14.69)
20	2177487.39	462142.91	5.51 (18.08)
21	2177484.70	462148.60	4.15 (13.61)
22	2177479.24	462151.51	4.82 (15.81)
23	2177467.40	462150.94	4.61 (15.11)
24	2177467.21	462153.99	5.81 (19.05)
26	2177464.50	462163.24	5.20 (17.07)
27	2177449.11	462168.41	4.56 (14.96)
28	2177447.11	462171.20	4.72 (15.47)
29	2177438.14	462172.76	4.63 (15.19)
30	2177450.94	462185.81	4.58 (15.03)
31	2177448.30	462193.71	4.30 (14.11)
32	2177438.44	462179.30	4.27 (14.00)
33	2177433.64	462178.40	4.57 (14.99)
34	2177444.08	462198.60	2.38 ( 7.80)
35	2177415.56	462186.10	4.35 (14.26)
36	2177406.34	462200.63	4.20 (13.79)
37	2177400.03	462203.18	4.92 (16.15)
38	2177384.88	462215.03	4.05 (13.30)
39	2177365.96	462226.70	4.83 (15.86)
41	2177348.26	462240.06	4.40 (14.45)
42	2177333.20	462252.00	4.69 (15.38)
43	2177328.40	462252.83	4.26 (14.00)
44	2177311.38	462261.64	4.58 (15.01)

(Sheet 3 of 11)

<b>Table 5 (Continued)</b>			
<b>1994 Survey (Continued)</b>			
<b>Target</b>	<b>Easting</b>	<b>Northing</b>	<b>Elevation, m (ft)</b>
<b>South Jetty (Continued)</b>			
45	2177299.26	462268.80	5.71 (18.73)
46	2177294.03	462276.73	5.48 (17.98)
47	2177277.40	462280.64	5.35 (17.54)
48	2177271.06	462286.74	5.07 (16.64)
49	2177270.43	462290.20	5.17 (16.95)
50	2177275.43	462303.44	3.65 (11.97)
52	2177261.78	462312.96	4.68 (15.37)
53	2177254.34	462327.46	2.89 ( 9.48)
54	2177242.60	462327.13	4.92 (16.15)
55	2177241.23	462329.06	4.20 (13.77)
56	2177231.34	462314.73	6.12 (20.09)
57	2177227.53	462323.38	5.45 (17.89)
58	2177221.98	462327.06	4.23 (13.88)
59	2177218.68	462326.80	5.08 (16.67)
60	2177212.36	462326.50	5.22 (17.13)
<b>1992 Survey</b>			
<b>Target</b>	<b>Easting</b>	<b>Northing</b>	<b>Elevation, m (ft)</b>
<b>North Jetty</b>			
1	2177523.75	462578.00	5.91 (19.40)
2	2177527.72	462571.58	4.17 (13.68)
3	2177530.65	462569.85	4.57 (14.98)
4	2177537.50	462567.98	6.04 (19.82)
5	2177533.73	462558.53	4.24 (13.92)
6	2177442.80	462697.98	4.84 (15.87)
7	2177448.20	462700.90	4.13 (13.55)
8	2177451.19	462689.55	5.94 (19.49)
9	2177467.33	462677.22	5.99 (19.66)
10	2177481.20	462673.63	5.59 (18.35)
11	2177483.82	462668.32	6.04 (19.80)
(Sheet 4 of 11)			

<b>Table 5 (Continued)</b>			
<b>1992 Survey (Continued)</b>			
<b>Target</b>	<b>Easting</b>	<b>Northing</b>	<b>Elevation, m (ft)</b>
North Jetty (Continued)			
13	2177495.72	462672.88	4.70 (15.41)
14	2177510.30	462683.92	3.76 (12.35)
15	2177524.89	462642.73	5.15 (16.92)
16	2177522.95	462647.25	4.82 (15.81)
17	2177532.77	462659.10	4.86 (15.94)
18	2177538.37	462636.67	4.10 (13.44)
19	2177554.69	462651.02	4.51 (14.79)
20	2177571.37	462643.52	4.57 (14.99)
21	2177578.29	462636.90	5.17 (16.96)
22	2177562.53	462616.48	5.05 (16.57)
23	2177563.89	462609.37	5.10 (16.72)
24	2177586.77	462632.51	4.48 (14.71)
25	2177582.47	462611.71	5.41 (17.74)
26	2177597.89	462610.01	4.60 (15.10)
27	2177603.67	462589.48	5.02 (16.47)
28	2177606.97	462588.41	5.29 (17.37)
29	2177620.70	462593.07	4.94 (16.22)
30	2177614.53	462579.90	5.72 (18.76)
31	2177613.99	462572.43	4.93 (16.15)
33	2177635.77	462564.15	4.50 (14.76)
34	2177618.42	462548.25	5.25 (17.23)
35	2177613.97	462544.17	5.38 (17.64)
36	2177621.20	462539.80	3.74 (12.28)
37	2177607.29	462538.60	4.99 (16.38)
38	2177609.45	462535.53	4.01 (13.16)
39	2177612.85	462529.37	4.27 (14.01)
40	2177616.69	462522.21	4.66 (15.30)
43	2177590.15	462529.25	4.88 (16.01)
45	2177576.93	462538.35	4.27 (14.00)
(Sheet 5 of 11)			

<b>Table 5 (Continued)</b>			
<b>1992 Survey</b>			
<b>Target</b>	<b>Easting</b>	<b>Northing</b>	<b>Elevation, m (ft)</b>
<b>North Jetty (Continued)</b>			
46	2177572.37	462541.58	5.27 (17.29)
47	2177568.83	462543.60	3.67 (12.05)
49	2177559.25	462547.97	4.40 (14.42)
50	2177554.83	462555.28	5.81 (19.06)
51	2177549.33	462560.27	4.02 (13.18)
<b>South Jetty</b>			
1	2177453.45	462120.93	5.10 (16.72)
2	2177353.45	462114.71	4.79 (15.72)
3	2177458.32	462113.98	5.30 (17.39)
4	2177463.57	462107.31	5.21 (17.10)
5	2177454.43	462096.70	3.63 (11.90)
6	2177477.09	462104.00	6.07 (19.91)
7	2177474.69	462098.10	4.44 (14.57)
8	2177481.27	462098.67	5.42 (17.77)
9	2177502.52	462083.30	4.68 (15.35)
10	2177506.69	462078.41	4.18 (13.72)
11	2177514.35	462073.81	5.18 (17.01)
12	2177535.20	462082.21	4.24 (13.90)
13	2177541.00	462102.57	4.14 (13.57)
14	2177537.72	462112.80	4.03 (13.21)
15	2177531.67	462116.77	4.68 (15.36)
16	2177515.53	462124.93	4.34 (14.24)
17	2177515.95	462137.71	3.96 (12.99)
18	2177514.55	462140.01	4.70 (15.42)
19	2177498.69	462138.11	4.58 (15.02)
20	2177487.95	462140.53	5.78 (18.97)
21	2177484.49	462148.57	4.31 (14.16)
22	2177479.53	462151.25	4.97 (16.31)
23	2177467.55	462150.80	4.72 (15.47)
24	2177467.40	462153.98	5.89 (19.32)
(Sheet 6 of 11)			

<b>Table 5 (Continued)</b>			
<b>1992 Survey (Continued)</b>			
<b>Target</b>	<b>Easting</b>	<b>Northing</b>	<b>Elevation, m (ft)</b>
<b>South Jetty (Continued)</b>			
26	2177464.30	462163.08	5.43 (17.81)
27	2177456.83	462165.87	4.63 (15.48)
28	2177447.80	462171.47	4.75 (15.59)
29	2177438.85	462172.63	4.71 (15.45)
30	2177450.92	462185.90	4.67 (15.33)
31	2177448.25	462193.60	4.38 (14.36)
32	2177439.20	462179.25	4.61 (15.13)
33	2177434.20	462177.93	4.63 (15.20)
34	2177444.20	462198.62	2.43 ( 7.98)
35	2177417.87	462186.35	4.77 (15.64)
36	2177406.60	462200.57	4.31 (14.14)
37	2177400.05	462203.02	5.02 (16.48)
38	2177384.87	462214.89	4.12 (13.51)
39	2177365.87	462226.73	4.87 (15.98)
41	2177348.23	462240.05	4.53 (14.85)
42	2177333.96	462251.58	5.03 (16.51)
43	2177328.45	462253.53	4.32 (14.17)
44	2177311.65	462260.39	4.79 (15.71)
45	2177300.13	462268.33	5.82 (19.10)
46	2177294.00	462276.52	5.53 (18.15)
47	2177280.50	462281.22	5.54 (18.17)
48	2177273.22	462284.97	5.13 (16.82)
49	2177270.40	462290.47	5.10 (16.73)
50	2177276.50	462301.87	3.75 (12.31)
52	2177261.70	462312.98	4.72 (15.50)
53	2177254.35	462327.13	2.96 ( 9.71)
54	2177243.29	462325.98	5.00 (16.39)
55	2177241.22	462328.77	4.26 (13.96)
56	2177231.49	462314.30	6.19 (20.32)
(Sheet 7 of 11)			

<b>Table 5 (Continued)</b>			
<b>1992 Survey (Continued)</b>			
<b>Target</b>	<b>Easting</b>	<b>Northing</b>	<b>Elevation, m (ft)</b>
<b>South Jetty (Continued)</b>			
57	2177227.02	462323.25	5.63 (18.47)
58	2177221.93	462326.95	4.26 (13.96)
59	2177218.73	462326.50	5.14 (16.87)
60	2177212.35	462326.43	5.23 (17.17)
<b>1984 Survey</b>			
<b>Target</b>	<b>Easting</b>	<b>Northing</b>	<b>Elevation, m (ft)</b>
<b>North Jetty</b>			
1	2177523.49	462578.06	5.89 (19.34)
2	2177527.83	462571.74	4.17 (13.68)
3	2177530.61	462569.84	4.61 (15.13)
4	2177537.52	462568.06	6.05 (19.85)
5	2177533.84	462558.51	4.28 (14.03)
6	2177442.68	462698.04	4.91 (16.12)
7	2177448.15	462700.92	4.13 (13.56)
8	2177450.70	462689.68	6.12 (20.09)
9	2177467.24	462677.19	6.07 (19.91)
10	2177481.33	462673.64	5.63 (18.46)
11	2177483.89	462668.32	6.09 (19.99)
13	2177495.70	462672.98	4.78 (15.70)
14	2177510.24	462683.88	3.83 (12.56)
15	2177525.10	462642.72	5.18 (16.98)
16	2177522.87	462646.84	4.89 (16.04)
17	2177532.69	462659.09	4.91 (16.10)
18	2177538.57	462636.45	4.18 (13.72)
19	2177554.60	462650.82	4.57 (14.98)
20	2177571.49	462643.48	4.60 (15.09)
21	2177578.38	462636.95	5.20 (17.06)
22	2177562.54	462616.56	5.09 (16.69)
23	2177563.76	462609.41	5.13 (16.84)
(Sheet 8 of 11)			

<b>Table 5 (Continued)</b>			
<b>1984 Survey (Continued)</b>			
<b>Target</b>	<b>Easting</b>	<b>Northing</b>	<b>Elevation, m (ft)</b>
<b>North Jetty (Continued)</b>			
24	2177586.87	462632.39	4.61 (15.11)
25	2177582.38	462611.59	5.45 (17.87)
26	2177598.13	462610.10	4.61 (15.11)
27	2177603.61	462589.17	5.12 (16.79)
28	2177606.89	462587.99	5.36 (17.59)
29	2177620.79	462592.84	5.00 (16.41)
30	2177614.57	462579.83	5.75 (18.85)
31	2177614.16	462572.22	4.97 (16.31)
33	2177636.76	462562.89	4.59 (15.05)
34	2177618.75	462547.73	5.24 (17.20)
35	2177614.67	462543.89	5.45 (17.87)
36	2177622.31	462540.37	4.43 (14.52)
37	2177607.28	462538.61	5.00 (16.41)
38	2177609.60	462535.13	3.97 (13.03)
39	2177616.55	462528.73	4.57 (14.98)
40	2177616.87	462522.27	4.70 (15.41)
43	2177590.11	462529.90	4.85 (15.90)
45	2177577.25	462538.19	4.33 (14.19)
46	2177572.30	462542.17	5.49 (18.00)
47	2177569.51	462543.62	3.70 (12.14)
49	2177559.57	462547.27	4.50 (14.76)
50	2177555.01	462555.17	5.84 (19.16)
51	2177549.14	462559.93	4.25 (13.93)
<b>South Jetty</b>			
1	2177453.30	462120.83	5.14 (16.87)
2	2177453.37	462114.63	4.78 (15.69)
3	2177458.32	462113.53	5.28 (17.32)
4	2177463.51	462107.27	5.20 (17.05)
5	2177454.56	462096.61	3.65 (11.96)
(Sheet 9 of 11)			

Table 5 (Continued)			
1984 Survey (Continued)			
Target	Easting	Northing	Elevation, m (ft)
South Jetty (Continued)			
6	2177477.20	462103.84	6.08 (19.94)
7	2177474.80	462097.97	4.47 (14.66)
8	2177481.33	462098.60	5.43 (17.82)
9	2177502.63	462083.19	4.71 (15.45)
10	2177506.89	462078.23	4.19 (13.74)
11	2177514.61	462073.92	5.27 (17.30)
12	2177535.33	462082.19	4.34 (14.25)
13	2177541.20	462102.14	4.23 (13.87)
14	2177537.85	462112.61	4.05 (13.30)
15	No data		
16	2177515.70	462124.70	4.34 (14.25)
17	2177515.56	462137.09	4.08 (13.40)
18	2177514.78	462139.45	4.73 (15.51)
19	2177499.00	462137.67	4.62 (15.15)
20	2177488.29	462140.23	5.80 (19.02)
21	2177484.57	462148.22	4.37 (14.35)
22	2177479.61	462150.95	5.02 (16.48)
23	2177467.51	462150.42	4.73 (15.51)
24	2177467.53	462153.71	5.89 (19.33)
26	2177464.36	462162.83	5.48 (17.99)
27	2177449.13	462167.85	4.73 (15.53)
28	2177447.90	462171.33	4.78 (15.67)
29	2177439.03	462172.50	4.70 (15.41)
30	2177451.03	462185.67	4.73 (15.53)
31	2177448.29	462193.35	4.45 (14.60)
32	2177439.28	462179.25	4.65 (15.25)
33	2177434.33	462177.93	4.68 (15.35)
34	2177444.40	462198.42	2.46 ( 8.08)
35	2177417.93	462186.15	4.78 (15.69)
36	2177406.68	462200.55	4.36 (14.29)
(Sheet 10 of 11)			

<b>Table 5 (Concluded)</b>			
<b>1984 Survey (Continued)</b>			
<b>Target</b>	<b>Easting</b>	<b>Northing</b>	<b>Elevation, m (ft)</b>
<b>South Jetty (Continued)</b>			
37	2177400.23	462202.97	5.06 (16.59)
38	2177384.89	462214.90	4.18 (13.72)
39	2177366.11	462226.71	4.90 (16.06)
41	2177348.10	462240.16	4.62 (15.17)
42	2177333.96	462251.58	5.03 (16.51)
43	2177328.26	462253.56	4.36 (14.31)
44	2177311.43	462259.77	4.96 (16.28)
45	2177300.16	462268.51	5.92 (19.43)
46	2177294.10	462276.55	5.59 (18.35)
47	2177280.76	462281.18	5.60 (18.37)
48	2177273.19	462284.77	5.20 (17.07)
49	2177270.43	462290.20	5.17 (16.95)
50	2177276.50	462301.73	3.87 (12.69)
52	2177261.53	462312.93	4.84 (15.88)
53	2177254.51	462327.09	3.08 (10.09)
54	2177243.66	462326.02	5.06 (16.59)
55	2177241.50	462328.73	4.36 (14.29)
56	2177231.65	462314.12	6.26 (20.55)
57	2177226.95	462322.89	5.73 (18.80)
58	2177221.93	462326.88	4.33 (14.19)
59	2177218.88	462326.41	5.22 (17.14)
60	2177212.48	462326.40	5.27 (17.28)
(Sheet 11 of 11)			

An analysis of movement data for the targeted dolosse on the north and south jetties was conducted which included the number of targets that were displaced in the horizontal and vertical directions and the range of movement for the various targets. The range of movement in the horizontal and vertical positions of the targeted dolosse on the north and south jetties is shown in Table 7. The number of targets that moved various distances in the horizontal and vertical directions between the 1984, 1992, and 1994 photogrammetric surveys is identified.

**Table 6**  
**Differences In Target Positions for 1984, 1992, and 1994 Surveys**

Differences in Target Positions from 1984 to 1992, m (ft)			
Target	Easting	Northing	Elevation
North Jetty			
1	0.079 (0.26)	0.018 (0.06)	0.018 (0.06)
2	0.034 (0.11)	0.049 (0.16)	0 (0)
3	0.012 (0.04)	0.003 (0.01)	-0.046 (-0.15)
4	0.006 (0.02)	0.024 (0.08)	-0.009 (-0.03)
5	0.034 (0.11)	0.006 (0.02)	-0.034 (-0.11)
6	0.037 (0.12)	0.018 (0.06)	-0.076 (-0.25)
7	0.015 (0.05)	0.006 (0.02)	-0.003 (-0.01)
8	0.149 (0.49)	0.040 (0.13)	-0.183 (-0.60)
9	0.027 (0.09)	0.009 (0.03)	-0.076 (-0.25)
10	0.040 (0.13)	0.003 (0.01)	-0.034 (-0.11)
11	0.021 (0.07)	0 (0)	-0.058 (-0.19)
13	0.006 (0.02)	0.030 (0.10)	-0.088 (-0.29)
14	0.018 (0.06)	0.012 (0.04)	-0.064 (-0.21)
15	0.064 (0.21)	0.003 (0.01)	-0.012 (-0.06)
16	0.024 (0.08)	0.125 (0.41)	-0.070 (-0.23)
17	0.024 (0.08)	0.003 (0.01)	-0.049 (-0.16)
18	0.061 (0.20)	0.067 (0.22)	-0.085 (-0.28)
19	0.027 (0.09)	0.061 (0.20)	-0.058 (-0.19)
20	0.037 (0.12)	0.012 (0.04)	-0.030 (-0.10)
21	0.027 (0.09)	0.015 (0.05)	-0.030 (-0.10)
22	0.003 (0.01)	0.024 (0.08)	-0.037 (-0.12)
23	0.040 (0.13)	0.012 (0.04)	-0.037 (-0.12)
24	0.030 (0.10)	0.037 (0.12)	-0.122 (-0.40)
25	0.027 (0.09)	0.037 (0.12)	-0.040 (-0.13)
26	0.073 (0.24)	0.027 (0.09)	-0.003 (-0.01)
27	0.018 (0.06)	0.094 (0.31)	-0.098 (-0.32)
28	0.024 (0.08)	0.128 (0.42)	-0.067 (-0.22)
29	0.027 (0.09)	0.070 (0.23)	-0.058 (-0.19)
30	0.012 (0.04)	0.021 (0.07)	-0.027 (-0.09)
31	0.052 (0.17)	0.064 (0.21)	-0.049 (-0.16)
33	0.302 (0.99)	0.384 (1.26)	-0.088 (-0.29)

(Sheet 1 of 10)

<b>Table 6 (Continued)</b>			
<b>Target</b>	<b>Easting</b>	<b>Northing</b>	<b>Elevation</b>
North Jetty (Continued)			
34	0.101 (0.33)	0.158 (0.52)	0.009 (0.03)
35	0.213 (0.70)	0.085 (0.28)	-0.070 (-0.23)
36	0.338 (1.11)	0.174 (0.57)	-0.683 (-2.24)
37	0.003 (0.01)	0.003 (0.01)	-0.009 (-0.03)
38	0.046 (0.15)	0.122 (0.40)	0.040 (0.13)
39	1.128 (3.70)	0.195 (0.64)	-0.296 (-0.97)
40	0.055 (0.18)	0.018 (0.06)	-0.034 (-0.11)
43	0.012 (0.04)	0.198 (0.65)	0.034 (0.11)
45	0.098 (0.32)	0.049 (0.16)	-0.058 (-0.19)
46	0.021 (0.07)	0.180 (0.59)	-0.216 (-0.71)
47	0.207 (0.68)	0.006 (0.02)	-0.027 (-0.09)
49	0.098 (0.32)	0.213 (0.70)	-0.104 (-0.34)
50	0.055 (0.18)	0.034 (0.11)	-0.030 (-0.10)
51	0.058 (0.19)	0.104 (0.34)	-0.229 (-0.75)
South Jetty			
1	0.046 (0.15)	0.030 (0.10)	-0.046 (-0.15)
2	0.024 (0.08)	0.024 (0.08)	0.009 (0.03)
3	0.003 (0.01)	0.137 (0.45)	0.021 (0.07)
4	0.018 (0.06)	0.012 (0.04)	0.015 (0.05)
5	0.040 (0.13)	0.027 (0.09)	-0.018 (-0.06)
6	0.034 (0.11)	0.049 (0.16)	-0.009 (-0.03)
7	0.034 (0.11)	0.040 (0.13)	-0.027 (-0.09)
8	0.018 (0.06)	0.021 (0.07)	-0.015 (-0.05)
9	0.034 (0.11)	0.034 (0.11)	-0.030 (-0.10)
10	0.061 (0.20)	0.055 (0.18)	-0.006 (-0.02)
11	0.079 (0.26)	0.034 (0.11)	-0.088 (-0.29)
12	0.040 (0.13)	0.006 (0.02)	-0.107 (-0.35)
13	0.061 (0.20)	0.131 (0.43)	-0.091 (-0.30)
14	0.040 (0.13)	0.058 (0.19)	-0.027 (-0.09)
15	No data for 1984		
16	0.052 (0.17)	0.070 (0.23)	-0.003 (-0.01)
17	0.119 (0.39)	0.189 (0.62)	-0.125 (-0.41)
18	0.070 (0.23)	0.171 (0.56)	-0.027 (-0.09)
(Sheet 2 of 10)			

Table 6 (Continued)			
Target	Easting	Northing	Elevation
South Jetty (Continued)			
19	0.094 (0.31)	0.134 (0.44)	-0.040 (-0.13)
20	0.104 (0.34)	0.091 (0.30)	-0.015 (-0.05)
21	0.024 (0.08)	0.107 (0.35)	-0.058 (-0.19)
22	0.024 (0.08)	0.091 (0.30)	-0.052 (-0.17)
23	0.012 (0.04)	0.116 (0.38)	-0.012 (-0.04)
24	0.040 (0.13)	0.082 (0.27)	-0.003 (-0.01)
26	0.018 (0.06)	0.076 (0.25)	-0.055 (-0.18)
27	2.347 (7.70)	0.604 (1.98)	-0.015 (-0.05)
28	0.030 (0.10)	0.043 (0.14)	-0.024 (-0.08)
29	0.055 (0.18)	0.040 (0.13)	0.012 (0.04)
30	0.034 (0.11)	0.070 (0.23)	-0.061 (-0.20)
31	0.012 (0.04)	0.076 (0.25)	-0.073 (-0.24)
32	0.024 (0.08)	0 (0)	-0.037 (-0.12)
33	0.040 (0.13)	0 (0)	-0.046 (-0.15)
34	0.061 (0.20)	0.061 (0.20)	-0.030 (-0.10)
35	0.018 (0.06)	0.061 (0.20)	-0.015 (-0.05)
36	0.024 (0.08)	0.006 (0.02)	-0.046 (-0.15)
37	0.055 (0.18)	0.015 (0.05)	-0.034 (-0.11)
38	0.006 (0.02)	0.003 (0.01)	-0.064 (-0.21)
39	0.073 (0.24)	0.006 (0.02)	-0.024 (-0.08)
41	0.040 (0.13)	0.034 (0.11)	-0.098 (-0.32)
42	0 (0)	0 (0)	0 (0)
43	0.058 (0.19)	0.009 (0.03)	-0.043 (-0.14)
44	0.667 (0.22)	0.189 (0.62)	-0.174 (-0.57)
45	0.009 (0.03)	0.055 (0.18)	-0.101 (-0.33)
46	0.030 (0.10)	0.009 (0.03)	-0.061 (-0.20)
47	0.079 (0.26)	0.012 (0.04)	-0.061 (-0.20)
48	0.009 (0.03)	0.061 (0.20)	-0.076 (-0.25)
49	0.009 (0.03)	0.082 (0.27)	-0.067 (-0.22)
50	0 (0)	0.043 (0.14)	-0.116 (-0.38)
52	0.052 (0.17)	0.015 (0.05)	-0.116 (-0.38)
53	0.049 (0.16)	0.012 (0.04)	-0.116 (-0.38)
54	0.113 (0.37)	0.012 (0.04)	-0.061 (-0.20)

(Sheet 3 of 10)

<b>Table 6 (Continued)</b>			
<b>Target</b>	<b>Easting</b>	<b>Northing</b>	<b>Elevation</b>
South Jetty (Continued)			
55	0.085 (0.28)	0.012 (0.04)	-0.101 (-0.33)
56	0.049 (0.16)	0.055 (0.18)	-0.070 (-0.23)
57	0.021 (0.07)	0.110 (0.36)	-0.111 (-0.33)
58	0 (0)	0.021 (0.07)	-0.070 (-0.23)
59	0.046 (0.15)	0.027 (0.09)	-0.082 (-0.27)
60	0.040 (0.13)	0.009 (0.03)	-0.034 (-0.11)
<b>Differences in Target Positions from 1992 to 1994, m (ft)</b>			
<b>Target</b>	<b>Easting</b>	<b>Northing</b>	<b>Elevation</b>
North Jetty			
1	0.094 (0.31)	0.213 (0.70)	-0.046 (-0.15)
2	0.018 (0.06)	0 (0)	-0.018 (-0.06)
3	0.155 (0.51)	0.094 (0.31)	-0.201 (-0.66)
4	0.030 (0.10)	0.079 (0.26)	-0.049 (-0.16)
5	0.488 (1.60)	0.122 (0.40)	-0.024 (-0.08)
6	0 (0)	0.030 (0.10)	-0.015 (-0.05)
7	0.012 (0.04)	0.009 (0.03)	-0.012 (-0.06)
8	0.058 (0.19)	0.009 (0.03)	-0.034 (-0.11)
9	0.030 (0.10)	0.027 (0.09)	-0.030 (-0.10)
10	0.049 (0.16)	0.003 (0.01)	0.009 (0.03)
11	0.055 (0.18)	0.079 (0.26)	-0.040 (-0.13)
13	0.085 (0.28)	0 (0)	-0.186 (-0.61)
14	0.049 (0.16)	0.012 (0.06)	-0.016 (-0.02)
15	0.070 (0.23)	0.122 (0.40)	-0.128 (-0.42)
16	0.027 (0.09)	0.177 (0.58)	-0.107 (-0.35)
17	0.021 (0.07)	0.012 (0.02)	-0.061 (-0.20)
18	0.034 (0.11)	0.058 (0.19)	-0.076 (-0.25)
19	0.015 (0.05)	0.055 (0.18)	-0.024 (-0.08)
20	0.021 (0.07)	0.024 (0.08)	-0.058 (-0.19)
21	0.003 (0.01)	0.070 (0.23)	-0.079 (-0.26)
22	0.009 (0.03)	0 (0)	-0.037 (-0.12)
23	0.034 (0.11)	0.012 (0.04)	-0.024 (-0.08)
24	0.274 (0.39)	0.137 (0.45)	-0.201 (-0.66)
25	0.027 (0.09)	0.040 (0.13)	-0.067 (-0.22)
(Sheet 4 of 10)			

<b>Table 6 (Continued)</b>			
<b>Target</b>	<b>Easting</b>	<b>Northing</b>	<b>Elevation</b>
North Jetty (Continued)			
26	0.223 (0.73)	0.155 (0.51)	0.064 (0.21)
27	0.040 (0.13)	0.213 (0.70)	-0.235 (-0.77)
28	0.079 (0.26)	0.009 (0.03)	-0.204 (-0.67)
29	0.037 (0.12)	0.021 (0.07)	-0.046 (-0.15)
30	0.052 (0.17)	0.018 (0.06)	-0.064 (-0.21)
31	0.088 (0.29)	0.198 (0.65)	-0.070 (-0.23)
33	0.070 (0.23)	0.125 (0.41)	-0.073 (-0.24)
34	0.006 (0.02)	0.046 (0.15)	-0.018 (-0.06)
35	0.430 (1.41)	0.043 (0.14)	-0.082 (-0.27)
36	0.360 (1.18)	0.232 (0.76)	0.683 (2.24)
37	1.234 (4.05)	1.225 (4.02)	0.018 (0.06)
38	0.936 (3.07)	0.229 (0.75)	-0.116 (-0.38)
39	0.210 (0.69)	0.064 (0.21)	-0.146 (-0.48)
40	1.878 (6.16)	0.582 (1.91)	-0.704 (-2.31)
43	0.747 (2.45)	0.969 (3.18)	-0.357 (-1.17)
45	0.174 (0.57)	0.546 (1.79)	-0.707 (-2.32)
46	1.289 (4.23)	0.914 (3.00)	-1.076 (-3.53)
47	0.546 (1.79)	0.939 (3.08)	0.732 (2.40)
49	1.338 (4.39)	1.167 (3.83)	-1.045 (-3.43)
50	0.436 (1.43)	1.109 (3.64)	-1.585 (-5.20)
51	0.088 (0.29)	0.101 (0.33)	-0.052 (-0.17)
South Jetty			
1	0.046 (0.15)	0.030 (0.10)	-0.064 (-0.21)
2	0.018 (0.06)	0.015 (0.05)	-0.052 (-0.17)
3	0.140 (0.46)	0.003 (0.01)	-0.094 (-0.31)
4	0.277 (0.91)	0.216 (0.71)	-0.256 (-0.84)
5	0.180 (0.59)	0.034 (0.11)	-0.067 (-0.22)
6	0.174 (0.57)	0.256 (0.84)	-1.149 (-3.77)
7	0.411 (1.35)	0.064 (0.21)	-0.131 (-0.43)
8	0.204 (0.67)	0.451 (1.48)	-0.098 (-0.32)
9	0.232 (0.76)	0.094 (0.31)	-0.177 (-0.58)
10	0.290 (0.95)	0.183 (0.60)	0.058 (0.19)
11	0.134 (0.44)	0.457 (1.50)	-0.832 (-2.73)
(Sheet 5 of 10)			

Table 6 (Continued)			
Target	Easting	Northing	Elevation
South Jetty (Continued)			
12	0.003 (0.01)	0.265 (0.87)	-0.143 (-0.47)
13	0.780 (2.56)	0.341 (1.12)	0.421 (1.38)
14	0.146 (0.48)	0.012 (0.04)	-0.018 (-0.06)
15	0.235 (0.77)	0.052 (0.17)	-0.143 (-0.47)
16	0.052 (0.17)	0.027 (0.09)	-0.049 (-0.16)
17	0.018 (0.06)	0.021 (0.07)	-0.046 (-0.15)
18	0.034 (0.11)	0.030 (0.10)	-0.058 (-0.19)
19	0.088 (0.29)	0.149 (0.49)	-0.101 (-0.33)
20	0.170 (0.56)	0.725 (2.38)	-0.271 (-0.89)
21	0.064 (0.21)	0.009 (0.03)	-0.168 (-0.55)
22	0.088 (0.29)	0.079 (0.26)	-0.152 (-0.50)
23	0.046 (0.15)	0.043 (0.14)	-0.110 (-0.36)
24	0.058 (0.19)	0.003 (0.01)	-0.082 (-0.27)
26	0.061 (0.20)	0.049 (0.16)	-0.226 (-0.74)
27	2.353 (7.72)	0.774 (2.54)	-0.158 (-0.52)
28	0.210 (0.69)	0.082 (0.27)	-0.037 (-0.12)
29	0.216 (0.71)	0.040 (0.13)	-0.079 (-0.26)
30	0.006 (0.02)	0.027 (0.09)	-0.091 (-0.30)
31	0.015 (0.05)	0.034 (0.11)	-0.076 (-0.25)
32	0.232 (0.76)	0.015 (0.05)	-0.344 (-1.13)
33	0.171 (0.56)	0.143 (0.47)	-0.064 (-0.21)
34	0.037 (0.12)	0.006 (0.02)	-0.055 (-0.18)
35	0.704 (2.31)	0.076 (0.25)	-0.421 (-1.38)
36	0.079 (0.26)	0.018 (0.06)	-0.107 (-0.35)
37	0.006 (0.02)	0.049 (0.16)	-0.101 (-0.33)
38	0.003 (0.01)	0.043 (0.14)	-0.064 (-0.21)
39	0.027 (0.09)	0.009 (0.03)	-0.037 (-0.12)
41	0.009 (0.03)	0.003 (0.01)	-0.122 (-0.40)
42	0.232 (0.76)	0.128 (0.42)	-0.344 (-1.13)
43	0.015 (0.05)	0.213 (0.70)	-0.052 (-0.17)
44	0.082 (0.27)	0.381 (1.25)	-0.213 (-0.70)
45	0.265 (0.87)	0.143 (0.47)	-0.122 (-0.40)
46	0.009 (0.03)	0.064 (0.21)	-0.052 (-0.17)

(Sheet 6 of 10)

<b>Table 6 (Continued)</b>			
<b>Target</b>	<b>Easting</b>	<b>Northing</b>	<b>Elevation</b>
South Jetty (Continued)			
47	0.945 (3.10)	0.177 (0.58)	-0.192 (-0.63)
48	0.658 (2.16)	0.539 (1.77)	-0.055 (-0.18)
49	0.009 (0.03)	0.082 (0.27)	0.067 (0.22)
50	0.326 (1.07)	0.479 (1.57)	-0.104 (-0.34)
52	0.024 (0.08)	0.006 (0.02)	-0.040 (-0.13)
53	0.003 (0.01)	0.101 (0.33)	-0.070 (-0.23)
54	0.210 (0.69)	0.351 (1.15)	-0.073 (-0.24)
55	0.003 (0.01)	0.088 (0.29)	-0.058 (-0.19)
56	0.046 (0.15)	0.131 (0.43)	-0.070 (-0.23)
57	0.155 (0.51)	0.040 (0.13)	-0.177 (-0.58)
58	0.015 (0.05)	0.034 (0.11)	-0.024 (-0.08)
59	0.015 (0.05)	0.091 (0.30)	-0.061 (-0.20)
60	0.003 (0.01)	0.021 (0.07)	-0.012 (-0.04)
<b>Differences in Target Positions from 1984 to 1992, m (ft)</b>			
<b>Target</b>	<b>Easting</b>	<b>Northing</b>	<b>Elevation</b>
North Jetty			
1	0.174 (0.57)	0.195 (0.64)	-0.027 (-0.09)
2	0.015 (0.05)	0.049 (0.16)	-0.018 (-0.06)
3	0.168 (0.55)	0.091 (0.30)	-0.247 (-0.81)
4	0.024 (0.08)	0.055 (0.18)	-0.058 (-0.19)
5	0.454 (1.49)	0.116 (0.38)	-0.058 (-0.19)
6	0.037 (0.12)	0.012 (0.04)	-0.091 (-0.30)
7	0.003 (0.01)	0.003 (0.01)	-0.021 (-0.07)
8	0.207 (0.68)	0.030 (0.10)	-0.216 (-0.71)
9	0.058 (0.19)	0.018 (0.06)	-0.107 (-0.35)
10	0.088 (0.29)	0 (0)	-0.024 (-0.08)
11	0.076 (0.25)	0.079 (0.26)	-0.098 (-0.32)
13	0.091 (0.30)	0.030 (0.10)	-0.274 (-0.90)
14	0.067 (0.22)	0.006 (0.02)	-0.058 (-0.19)
15	0.134 (0.44)	0.125 (0.41)	-0.146 (-0.48)
16	0.052 (0.17)	0.302 (0.99)	-0.177 (-0.58)
17	0.003 (0.01)	0.003 (0.01)	-0.110 (-0.36)
18	0.095 (0.31)	0.125 (0.41)	-0.162 (-0.53)
(Sheet 7 of 10)			

<b>Table 6 (Continued)</b>			
<b>Target</b>	<b>Easting</b>	<b>Northing</b>	<b>Elevation</b>
North Jetty (Continued)			
19	0.043 (0.14)	0.116 (0.38)	-0.082 (-0.27)
20	0.015 (0.05)	0.037 (0.12)	-0.088 (-0.29)
21	0.030 (0.10)	0.055 (0.18)	-0.110 (-0.36)
22	0.012 (0.04)	0.024 (0.08)	-0.073 (-0.24)
23	0.073 (0.24)	0.024 (0.08)	-0.061 (-0.20)
24	0.149 (0.49)	0.174 (0.57)	-0.323 (-1.06)
25	0 (0)	0.076 (0.25)	-0.091 (-0.35)
26	0.296 (0.97)	0.183 (0.60)	0.061 (0.20)
27	0.021 (0.07)	0.308 (1.01)	-0.332 (-1.09)
28	0.104 (0.34)	0.119 (0.39)	-0.271 (-0.89)
29	0.064 (0.21)	0.091 (0.30)	-0.104 (-0.34)
30	0.040 (0.13)	0.003 (0.01)	-0.091 (-0.30)
31	0.140 (0.46)	0.262 (0.86)	-0.119 (-0.39)
33	0.372 (1.22)	0.509 (1.67)	-0.162 (-0.53)
34	0.094 (0.31)	0.204 (0.67)	-0.009 (-0.03)
35	0.643 (2.11)	0.043 (0.14)	-0.152 (-0.50)
36	0.021 (0.07)	0.058 (0.19)	0 (0)
37	1.231 (4.04)	1.228 (4.03)	-0.009 (0.03)
38	0.981 (3.22)	0.107 (0.35)	-0.076 (-0.25)
39	1.338 (4.39)	0.131 (0.43)	-0.442 (-1.45)
40	1.932 (6.34)	0.600 (1.97)	-0.738 (-2.42)
43	0.735 (2.41)	0.771 (2.53)	-0.323 (-1.06)
45	0.271 (0.89)	0.497 (1.63)	-0.765 (-2.51)
46	1.268 (4.16)	1.094 (3.59)	-1.292 (-4.24)
47	0.753 (2.47)	0.933 (3.06)	0.704 (2.31)
49	1.436 (4.71)	0.954 (3.13)	-1.149 (-3.77)
50	0.381 (1.25)	1.076 (3.53)	-1.615 (-5.30)
51	0.030 (0.10)	0.003 (0.01)	-0.280 (-0.92)
South Jetty			
1	0 (0)	0 (0)	-0.110 (-0.36)
2	0.043 (0.14)	0.040 (0.13)	-0.043 (-0.14)
3	0.143 (0.47)	0.140 (0.46)	-0.073 (-0.24)
4	0.259 (0.85)	0.204 (0.67)	-0.241 (-0.79)
(Sheet 8 of 10)			

<b>Table 6 (Continued)</b>			
<b>Target</b>	<b>Easting</b>	<b>Northing</b>	<b>Elevation</b>
South Jetty (Continued)			
5	0.219 (0.72)	0.006 (0.02)	-0.085 (-0.28)
6	0.140 (0.46)	0.207 (0.68)	-1.158 (-3.80)
7	0.445 (1.46)	0.024 (0.08)	-0.158 (-0.52)
8	0.186 (0.61)	0.430 (1.41)	-0.113 (-0.37)
9	0.265 (0.87)	0.128 (0.42)	-0.207 (-0.68)
10	0.351 (1.15)	0.128 (0.42)	0.052 (0.17)
11	0.213 (0.70)	0.424 (1.39)	-0.920 (-3.02)
12	0.037 (0.12)	0.259 (0.85)	-0.250 (-0.82)
13	0.841 (2.76)	0.472 (1.55)	0.329 (1.08)
14	0.186 (0.61)	0.070 (0.23)	-0.046 (-0.15)
16	0.104 (0.34)	0.043 (0.14)	-0.052 (-0.17)
17	0.137 (0.45)	0.168 (0.55)	-0.171 (-0.56)
18	0.104 (0.34)	0.140 (0.46)	-0.085 (-0.28)
19	0.183 (0.60)	0.283 (0.93)	-0.140 (-0.46)
20	0.274 (0.90)	0.817 (2.68)	-0.287 (-0.94)
21	0.040 (0.13)	0.116 (0.38)	-0.226 (-0.74)
22	0.113 (0.37)	0.171 (0.56)	-0.204 (-0.67)
23	0.034 (0.11)	0.158 (0.52)	-0.122 (-0.40)
24	0.098 (0.32)	0.085 (0.28)	-0.085 (-0.28)
26	0.043 (0.14)	0.125 (0.41)	-0.280 (-0.92)
27	0.006 (0.02)	0.171 (0.56)	-0.174 (-0.57)
28	0.241 (0.79)	0.040 (0.13)	-0.061 (-0.20)
29	0.271 (0.89)	0.079 (0.26)	-0.067 (-0.22)
30	0.027 (0.09)	0.043 (0.14)	-0.152 (-0.50)
31	0.003 (0.01)	0.110 (0.36)	-0.149 (-0.49)
32	0.256 (0.84)	0.015 (0.05)	-0.381 (-1.25)
33	0.210 (0.69)	0.143 (0.47)	-0.183 (-0.36)
34	0.098 (0.32)	0.055 (0.18)	-0.085 (-0.28)
35	0.722 (2.37)	0.015 (0.05)	-0.436 (-1.43)
36	0.104 (0.34)	0.024 (0.08)	-0.152 (-0.50)
37	0.061 (0.20)	0.064 (0.21)	-0.134 (-0.44)
38	0.003 (0.01)	0.040 (0.13)	-0.128 (-0.42)
39	0.046 (0.15)	0.003 (0.01)	-0.061 (-0.20)
(Sheet 9 of 10)			

Table 6 (Concluded)			
Target	Easting	Northing	Elevation
South Jetty (Continued)			
41	0.049 (0.16)	0.030 (0.10)	-0.219 (-0.72)
42	0.232 (0.76)	0.128 (0.42)	-0.344 (-1.13)
43	0.043 (0.14)	0.223 (0.73)	-0.094 (-0.31)
44	0.015 (0.05)	0.570 (1.87)	-0.387 (-1.27)
45	0.274 (0.90)	0.088 (0.29)	-0.223 (-0.73)
46	0.021 (0.07)	0.055 (0.18)	-0.113 (-0.37)
47	1.024 (3.36)	0.165 (0.54)	-0.253 (-0.83)
48	0.649 (2.13)	0.600 (1.97)	-0.131 (-0.43)
49	0 (0)	0 (0)	0 (0)
50	0.326 (1.07)	0.521 (1.71)	-0.219 (-0.72)
52	0.076 (0.25)	0.009 (0.03)	-0.155 (-0.51)
53	0.052 (0.17)	0.113 (0.37)	-0.186 (-0.61)
54	0.323 (1.06)	0.338 (1.11)	-0.134 (-0.44)
55	0.082 (0.27)	0.101 (0.33)	-0.158 (-0.52)
56	0.094 (0.31)	0.186 (0.61)	-0.140 (-0.46)
57	0.177 (0.58)	0.149 (0.49)	-0.277 (-0.91)
58	0.015 (0.05)	0.055 (0.18)	-0.094 (-0.31)
59	0.061 (0.20)	0.119 (0.39)	-0.143 (-0.47)
60	0.037 (0.12)	0.030 (0.10)	-0.046 (-0.15)
(Sheet 10 of 10)			

An analysis of movement data for the targeted dolosse on the north and south jetties indicates the armor units have been dynamic since the initial monitoring program ended in 1984. Between 1984 and 1994, movement of the dolosse targets in the horizontal (northing and easting) directions ranged from 0.003 m (0.01 ft) to 1.932 m (6.34 ft), and vertical displacement has ranged from 0.009 m (0.03 ft) to 1.615 m (5.3 ft). In some cases, the targets moved in one direction between 1984 and 1992, and back in the opposite direction between the 1992 and 1994 survey. In general, most of the movements have been less than 0.3 m (1 ft). From 1984 to 1994, about 73 percent of the targeted units on the north jetty and 86 percent of the targeted units on the south jetty have fluctuated less than 0.3 m (1 ft). Conversely, about 13 and 4 percent of the north and south jetty targeted units, respectively, have moved distances greater than 0.9 m (3 ft). With regard to elevation changes between 1984 and 1994, 93 percent of the targeted dolosse on the north jetty and 95 percent of the targets on the south jetty have subsided. During intermediate surveys, 1984 to 1992 and 1992 to 1994, some units may have moved

<b>Table 7</b>				
<b>Number of Targets Moving in Directions Indicated/Per Survey</b>				
<b>Direction of Movement</b>	<b>Range of Movement in Target Positions, m (ft)</b>			
	<b>0-0.3 (0-1)</b>	<b>0.3-0.6 (1-2)</b>	<b>0.6-0.9 (2-3)</b>	<b>&gt;0.9 (&gt;3)</b>
North Jetty (1984 to 1992)				
Easting	43	1	0	1
Northing	44	1	0	0
Elevation	44	1	0	0
South Jetty (1984 to 1992)				
Easting	55	1	0	0
Northing	55	1	0	0
Elevation	56	0	0	0
North Jetty (1992 to 1994)				
Easting	34	5	1	5
Northing	37	2	1	5
Elevation	37	1	4	3
South Jetty (1992 to 1994)				
Easting	50	2	3	2
Northing	48	7	2	0
Elevation	51	4	1	1
North Jetty (1984 to 1994)				
Easting	33	3	3	6
Northing	35	4	1	5
Elevation	35	4	3	3
South Jetty (1984 to 1994)				
Easting	48	4	3	1
Northing	48	7	1	0
Elevation	49	5	0	2

upward for one survey and then downward for the subsequent survey or vice versa.

Between 1984 and 1994, the average movement of the targets on the north jetty was 0.24, 0.30, and 0.24 m (0.8, 1.0, and 0.8 ft) in the northing and easting horizontal directions and the vertical direction, respectively. On the south jetty, the average movement of the targets between 1984 and 1994 in the northing and easting horizontal directions and the vertical direction were 0.15, 0.21, and 0.18 m (0.5, 0.7, and 0.6 ft), respectively. Between 1984 and 1992, the average movement of targets on the north jetty was 0.06, 0.09, and 0.09 m

(0.2, 0.3, and 0.3 ft) in the northing and easting horizontal directions and the vertical direction, respectively; and between 1992 and 1994, these movements on the average were 0.24, 0.27, and 0.21 m (0.8, 0.9, and 0.7 ft). For the south jetty, the average movement of targets between 1984 and 1992 was 0.06, 0.09, and 0.06 m (0.2, 0.3, and 0.2 ft) in the northing and easting horizontal directions and the vertical direction, respectively; and between 1992 and 1994, these average movements were 0.15, 0.18, and 0.15 m (0.5, 0.6, and 0.5 ft). These data, along with the range of movement data presented previously for the various surveys, indicate that more movement occurred between 1992 and 1994 than during the 8-year period from 1984 to 1992.

Data analysis also indicates that movement of targeted dolosse on the north jetty in all directions has been slightly greater than the movement of units on the south jetty since 1984. Targeted units with the greatest horizontal displacements were concentrated along the inside head of the north jetty. These units generally moved in a southwesterly to westerly direction along the structure.

Horizontal displacement of the targets, in general, along the structure was in several directions, with movement away from the jetty center lines for some units and toward the center line for others. Target movement also occurred parallel to the jetty center lines both in the shoreward and seaward directions. There was no dominance in these movement directions for targets on the north jetty, but for south jetty targets, dominant movement was parallel to the jetty trunk toward the shore.

Comparisons of armor unit movement data to this point have included only target data and not movement of the entire armor unit. Therefore, to assess the motions of the entire armor unit, outlines of each targeted dolos were extracted from the stereo models and compared for the 1984, 1992, and 1994 surveys. These comparisons depicted horizontal positions, and actual distances moved were scaled off photogrammetric maps that were prepared. To determine vertical movements of the targeted armor units, additional elevations were obtained from the stereo models at one or two additional points on the dolosse (points other than the established targets). Examples of the targeted armor unit positions and additional elevations for the three surveys are shown in Figure 26.

Evaluation of horizontal motions of the targeted dolosse indicated that, for the majority of units, movement was relatively uniform. The entire unit tended to move in the same direction that the target had moved (linear as opposed to rotational). Only 31 percent of the targeted armor units on the north jetty and 20 percent of those on the south jetty rotated in either a clockwise or counterclockwise direction. Considering all the rotated armor units on both structures, there was not a dominance of clockwise or counterclockwise rotation observed. However, the majority of the armor units that rotated on the south sides of the jetties tended to move in a clockwise direction while those on the north sides of the jetties tended to rotate in counterclockwise directions. In general, randomly placed dolosse tend to be oriented with one fluke positioned near vertical and the other laying near horizontal. In some cases, the vertical fluke is

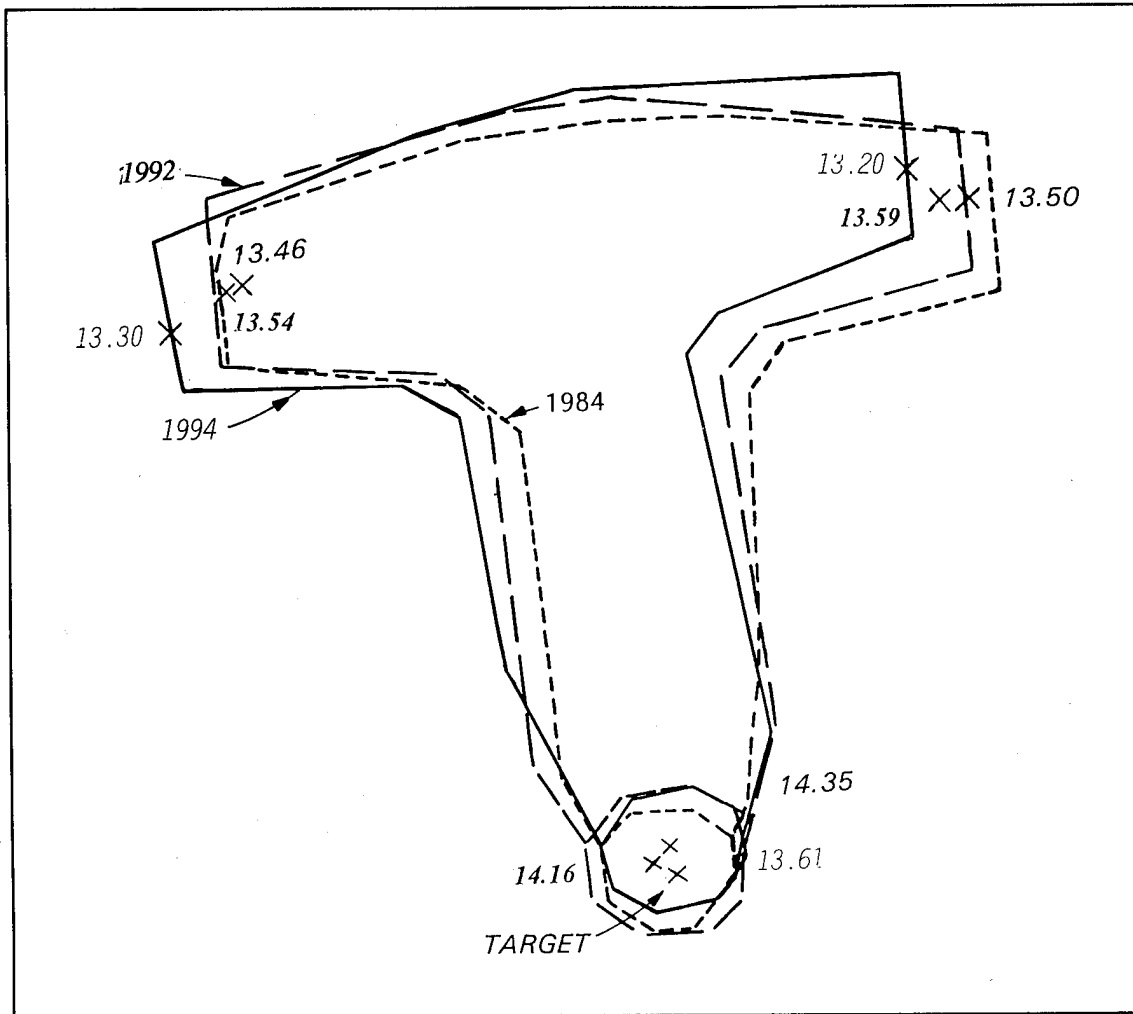

Figure 26. Example of targeted armor unit horizontal positions and additional elevations obtained for the various photogrammetric surveys

positioned nearer to the jetty center line and the horizontal portion downslope farther from the jetty center line. In other instances, the horizontal fluke is placed closer to the center line, with the vertical fluke farther away downslope. Of the targeted armor units that rotated on the jetties, the majority consisted of those placed with the vertical fluke farther downslope and the horizontal fluke closer to the jetty center line. The units observed with the greatest rotations were those placed along the head of the north jetty. Considering movements of the entire armor unit, maximum horizontal displacements for any point on the targeted dolosse on the north and south jetties were approximately 2 m (6.6 ft) and 1.25 m (4.1 ft), respectively, between 1984 and 1994. The averages of the maximum horizontal movements for the targeted dolosse during this time frame were 0.51 m (1.67 ft) and 0.32 m (1.06 ft), respectively, for the north and south jetties. On the north jetty, 61 percent of the targeted units and 65 percent of those targeted on the south jetty had maximum horizontal movements of 0.3 m (1.0 ft) or less at any point on the targeted dolosse.

Similar to the results of target data only, maximum horizontal movements, considering displacement of the entire unit, were concentrated along the head of the north jetty on its channel side. Data also indicated more significant movement between 1992 and 1994 as compared to the period between 1984 and 1992.

Evaluation of the vertical motions of the targeted dolosse revealed that the majority of the units showed a slight subsidence. A comparison of the vertical data between 1984 and 1994 indicated the average subsidence of all points on the targeted units was 0.21 m (0.68 ft) and 0.16 m (0.54 ft) for the north and south jetties, respectively. The maximum vertical displacement for any point on a targeted dolos on the north jetty was 1.6 m (5.3 ft), and the maximum subsidence for any point on a targeted dolos on the south jetty was 1.1 m (3.7 ft). Considering all the targeted units, the downslope portions of the dolosse subsided slightly more than the upslope portions. Data revealed that the downslope portions of the armor units subsided more than the upslope portions for 56 percent of the targeted units on the north jetty and for 54 percent of those targeted on the south structure between 1984 and 1994. The orientation of the dolosse on the structures relative to vertical displacements revealed that when the vertical flukes are upslope and the horizontal flukes are downslope, the downslope horizontal flukes subsided more than the upslope portions for 72 percent of the targeted units on the north jetty and 60 percent of those targeted on the south structure. When the orientation of the vertical flukes was downslope, with the horizontal flukes upslope, the upslope horizontal flukes subsided more for 55 percent of the units on the north jetty, but the vertical downslope flukes subsided more for 55 percent of the units on the south jetty. In general, it was noted that more significant vertical displacement occurred between 1992 and 1994 as opposed to the period between 1984 and 1992.

Evaluation of movement data to this point indicates that both horizontal and vertical movements of the targeted dolosse on the Manasquan Inlet jetties between 1992 and 1994 were greater than the 8-year period between 1984 and 1992. This is likely attributed to the occurrence of an unusual number of relatively intense extratropical storms ("northeasters") during the period October 1991 through March 1994 which impacted the coastline of the mid-Atlantic states, including the vicinity of Manasquan Inlet in New Jersey. Although no single parameter of a storm uniquely describes the coastal erosion and damage potential of that event, tide gauge data are the most widely used (though inexact) indicators of storm damage potential because of the role of elevated water levels which usually accompany the high winds and waves of storms. During this period, three storm events occurred - October 1991, December 1992, and March 1994 - which rank in the top 20 events at Atlantic City, NJ, based on maximum stage, covering a period of record back to 1911. In the same period, three storms - January 1992, December 1992, and March 1994 - produced maximum stages at Lewes, DE, which rank in the top ten storm events for the period of record back to 1919.

In addition to the targeted armor units, additional (nontargeted) dolosse were selected on the north and south jetties for comparison of movement data between the 1984 and 1994 surveys. The locations of these additional armor units are shown in Figures 27 and 28. On the north jetty, 41 dolosse were selected, and 38 were selected on the south jetty. Outlines of these additional dolosse, as well as elevations at two or three points on each unit, were obtained from the stereo models for the two surveys and compared on photogrammetric maps to determine horizontal and vertical motions, similar to the procedures used on the targeted units.

Evaluation of the horizontal motions of the additional dolosse indicated that movement was relatively uniform for over half of the armor units, in that the entire unit tended to move in the same direction (nonrotational movement). On the north jetty, 46 percent of the dolosse rotated in either a clockwise or counterclockwise direction and on the south jetty, 42 percent rotated. Considering all the rotated armor units on both jetties, there was not a dominance of clockwise or counterclockwise rotation. However, on the north side of the north jetty there was a dominance of counterclockwise rotation, while clockwise rotation dominated among armor units around the head and south side of the jetty. For the south jetty armor units, clockwise rotation also was dominant around the head and south side of the jetty, but there was no dominance of rotation direction along the north side of the jetty. In general, of the additional (nontargeted) armor units analyzed that rotated on the jetties, the majority consisted of those oriented with the vertical fluke farther downslope and the horizontal fluke closer to the jetty center line. Between 1984 and 1994, maximum horizontal displacements for any point on the additional selected armor units were 1.43 m (4.7 ft) and 0.91 m (3.0 ft) on the north and south jetties, respectively. The averages of the maximum horizontal movements of the additional selected dolosse, between 1984 and 1994, were 0.34 m (1.11 ft) and 0.33 m (1.08 ft) for the north and south jetties, respectively. Seventy percent of the units on the north jetty and sixty-six percent of those on the south jetty had maximum horizontal movements of 0.3 m (1.0 ft) or less at any point on the additional selected (nontargeted) dolosse. In general, based on the photogrammetric analysis, horizontal displacements for the nontargeted armor units were similar to those obtained for the targeted units.

Evaluation of the vertical motions of the additional dolosse revealed that the majority of the units subsided slightly. Comparisons of the vertical data for the nontargeted units indicated average subsidence of 0.18 m (0.6 ft) and 0.16 m (0.54 ft), respectively, for the north and south jetties. The maximum vertical displacement for any point on a dolos on the north jetty was 0.91 m (3.0 ft), and the maximum subsidence for any point on a dolos on the south jetty was 1.5 m (5.0 ft). The downslope portions of the nontargeted dolosse subsided slightly more than the upslope portions on the north jetty. Data indicated that the downslope portions of the armor units subsided more than the upslope portions for 52 percent of the units on the north jetty. For the south jetty, there was no dominance of subsidence between the downslope and upslope portions of the units. Approximately half the units had greater subsidence on their upslope portions and half had greater subsidence on their

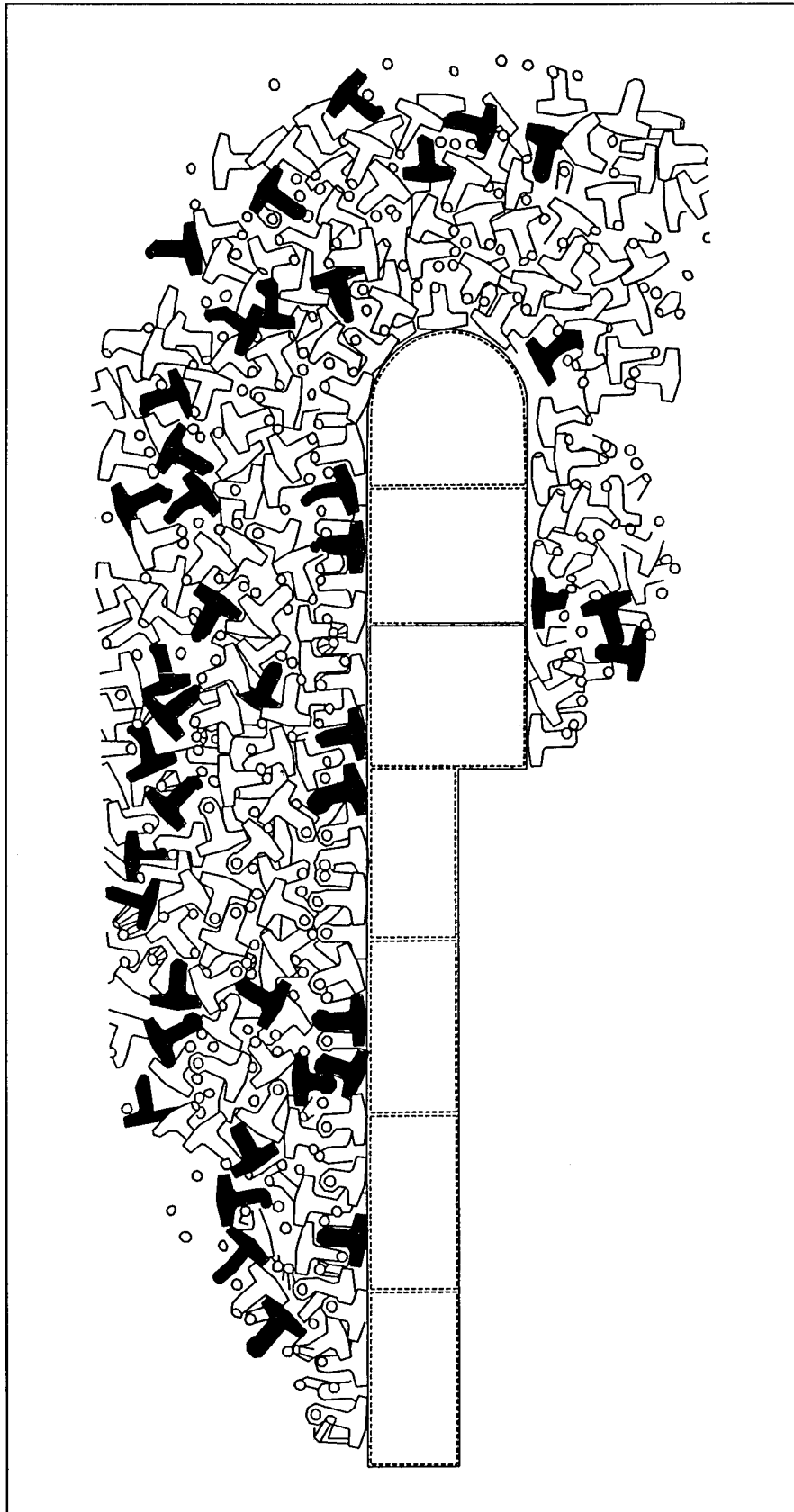

Figure 27. Non-targeted armor units selected for analysis on the north jetty

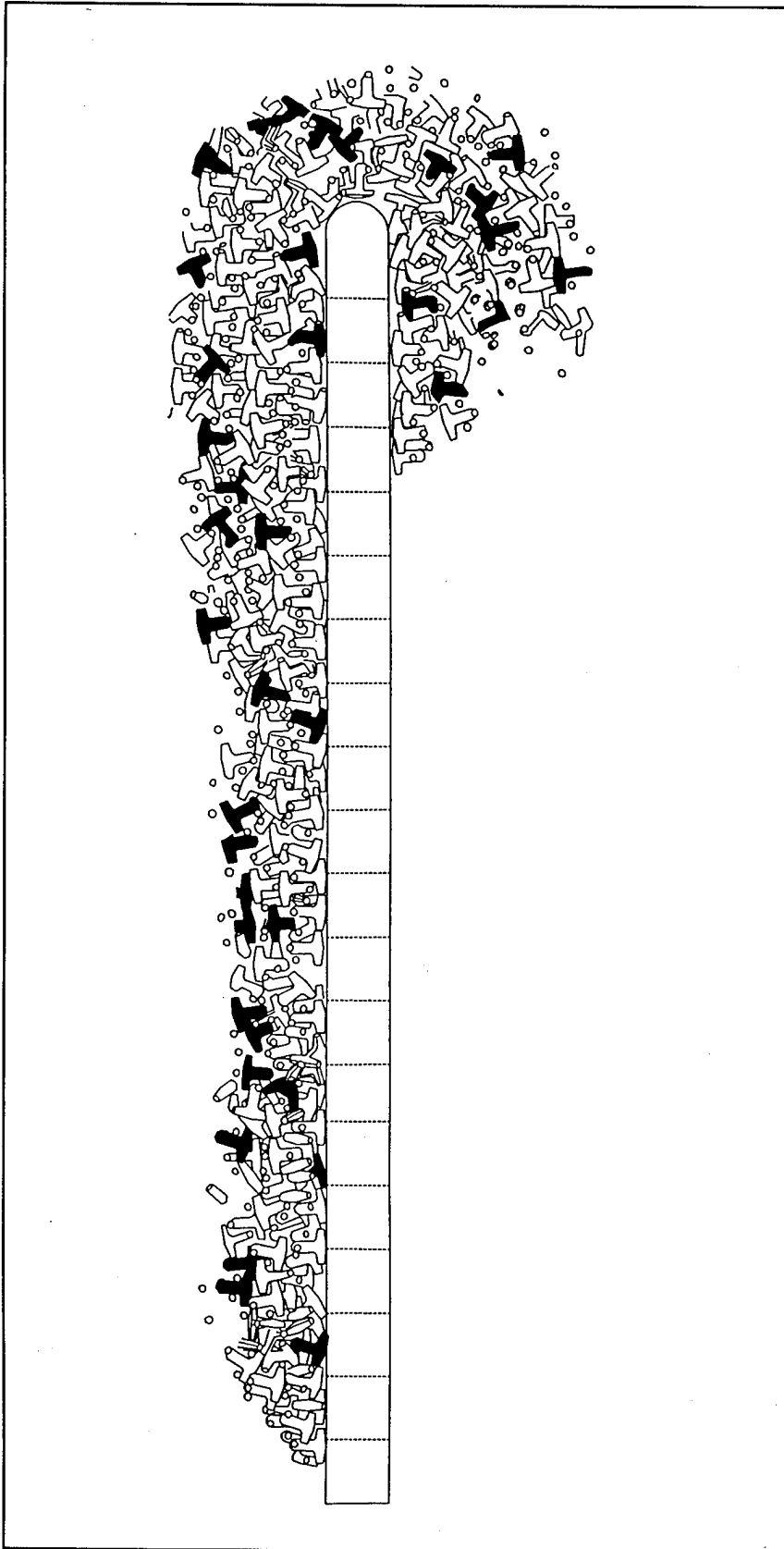

Figure 28. Non-targeted armor units selected for analysis on the south jetty

downslope portions. When the orientation of the vertical flukes of the dolosse were upslope and the horizontal flukes were downslope, the horizontal downslope flukes subsided more for 78 percent of the units on the north jetty and 62 percent of the dolosse on the south structure. When the orientation of the vertical flukes was downslope, with the horizontal flukes upslope, the upslope horizontal flukes subsided more for 57 percent of the units on the north jetty and 64 percent of those on the south jetty.

Examination of the armor unit positions for the 1994 survey revealed missing units (void) along the inside of the head of the north jetty. This void is illustrated in Figures 29 and 30, which show all visible armor units along the channel side of the head of the north structure for 1984 and 1994. The missing units were probably lost during storms occurring between 1992 and 1994 when, as indicated earlier, maximum horizontal movements were concentrated along the head of the north jetty. The structure appears to be in good condition; however, additional dolosse are required in this damaged area for the structure to maintain its design cross section stability. It should be noted that, with the exception of the temporary maintenance mentioned earlier at the head of the south jetty in 1995, no other maintenance has been performed on the jetties since the rehabilitation was completed in 1982.

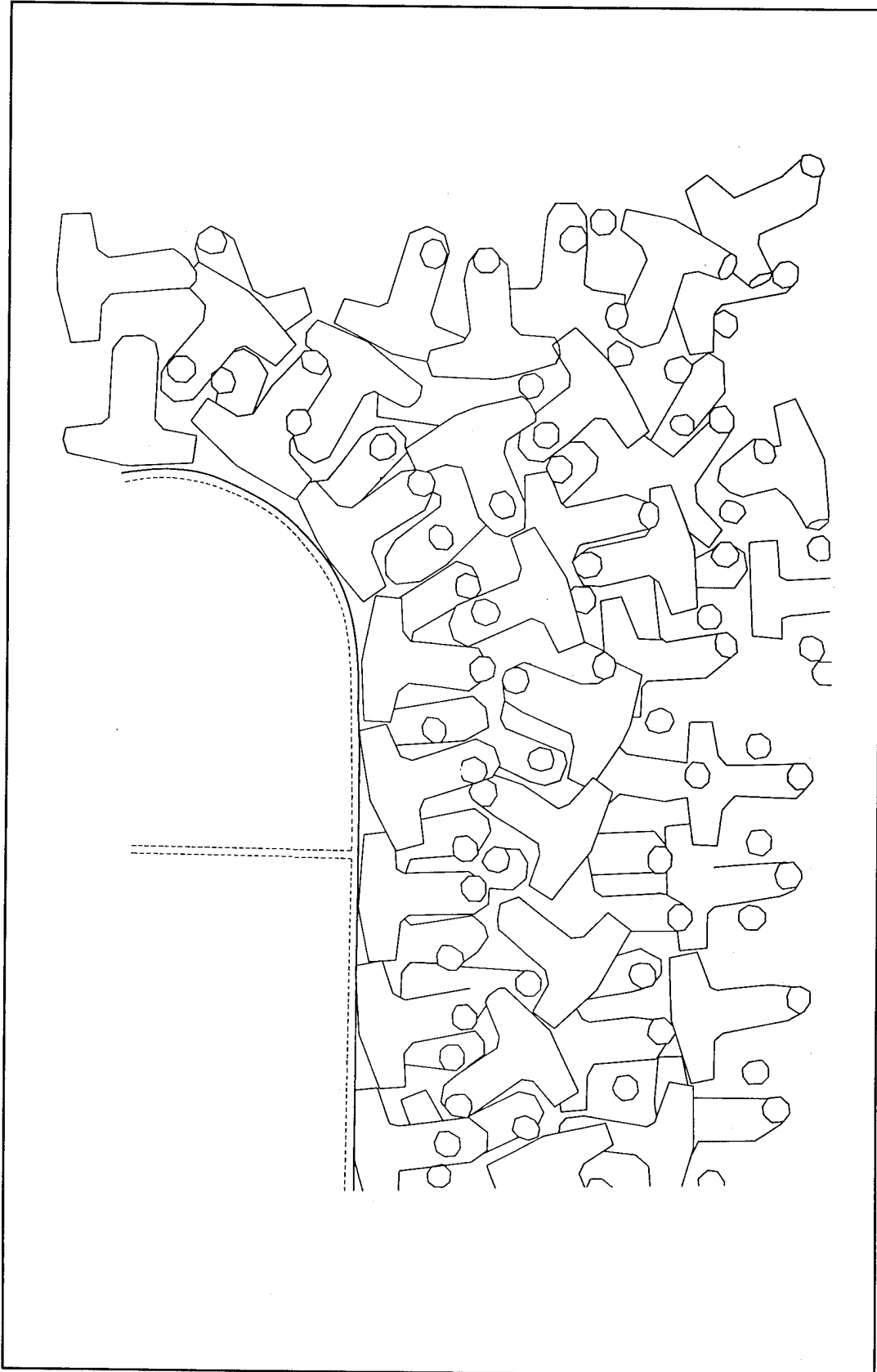

Figure 29. Visible armor units along channel side of north jetty during 1984 survey

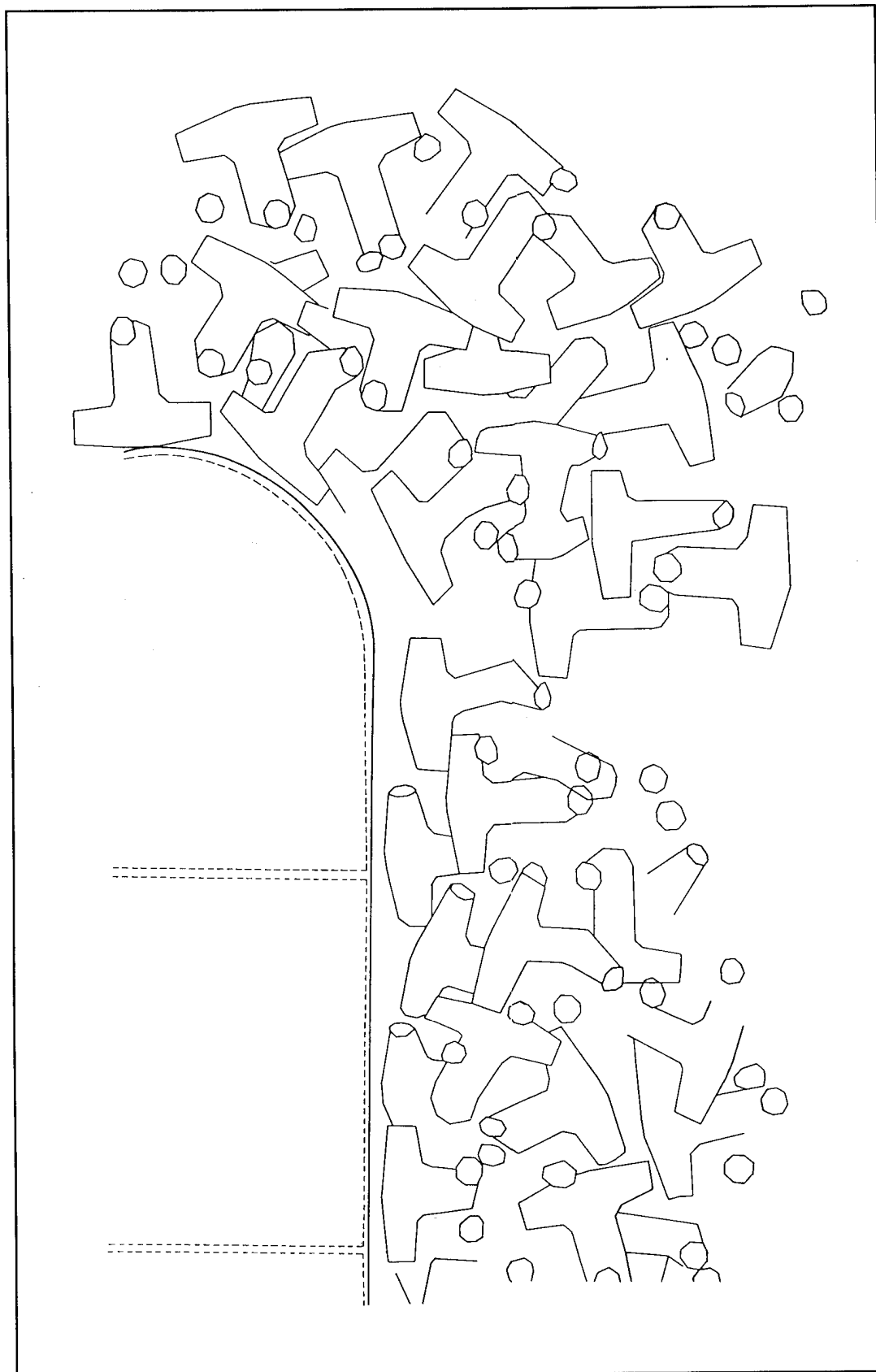

Figure 30. Visible armor units along channel side of north jetty during 1994 survey

## 4 Summary

---

Data were originally obtained for the dolos-armed Manasquan Inlet jetties during a monitoring effort conducted over the time period 1982-1984 under the M CCP Research Program. Armor unit breakage was documented, and quantitative data regarding armor unit movement were obtained. By means of limited ground-based surveys, aerial photography, and photogrammetric analysis, very precise base level conditions were established in 1984 for the dolos-armed jetties at Manasquan Inlet. Similar data (measurements funded by the Philadelphia District) were obtained in 1992; however, a detailed analysis was not completed due to nonavailability of resources (time and funds).

Under the current Periodic Inspections work unit of the M CCP Research Program, targets were reestablished and limited ground-based surveys, aerial photography, and photogrammetric analysis were completed and compared with previous data to analyze the entire above-water armor unit fields and quantify armor unit movement. A broken armor unit survey also was conducted during this effort and was compared to previous survey data. During the current monitoring effort, detailed analyses regarding horizontal and vertical displacements were conducted, not only for the targets established on the dolosse, but for the entire armor unit. Comparisons were made for the 1984, 1992, and current (1994) surveys. Also, using photogrammetric techniques, additional (nontargeted) dolosse were selected for analysis of armor unit movement between the 1984 and 1994 surveys.

Results of the monitoring effort indicate that the dolosse on the north and south jetties have been dynamic since their placement. Horizontal movement has ranged up to 2 m (6.6 ft) and vertical displacement (subsidence) as much as 1.6 m (5.3 ft). In general, however, most movements in both the horizontal and vertical directions have been less than 0.3 m (1.0 ft). Data analysis indicates dolosse movement on the north jetty has been slightly greater than the movement of units on the south jetty.

Horizontal movement for the majority of the dolosse was relatively uniform. The entire unit tended to move in the same direction as opposed to rotating. Of the units that rotated, however, the majority of those on the south sides of the jetties tended to move in a clockwise direction, while those on the north sides of the jetties tended to rotate in counterclockwise directions. Units with the greatest horizontal displacements were concentrated along the inside

head of the north jetty. Armor unit positions from photogrammetric maps also revealed missing armor units at the waterline along the head of the north jetty on its channel side.

Evaluation of the vertical motions of the armor units revealed that the majority of the dolosse on the jetties have subsided slightly. In general, the downslope portions of the armor units have tended to subside more than the upslope portions. The horizontal flukes of the dolosse also tended to subside slightly more than the vertical flukes regardless of dolosse orientation on the jetty.

The current broken armor unit survey revealed 17 broken/cracked dolosse as opposed to 5 in 1984. The only area of concern was at the head of the south jetty where a broken unit resulted in exposure of core stone under the jetty cap. A temporary repair was subsequently performed by the Philadelphia District.

Overall, the jetties appear to be in good structural condition and are functioning as intended. To maintain the design cross-section stability of the structure, additional dolosse are required in the void along the inside head of the north jetty, and at the tip of the south jetty where the core stone is exposed. With the exception of the recent temporary repair at the head of the south jetty, no maintenance has been performed on the Manasquan Inlet jetties since rehabilitation was completed in 1982.

Methodology has been developed to assess the long-term response of the jetties to their environment at Manasquan Inlet. Comparison of armor unit data in future years will be conducted under the Periodic Inspections work unit to gather data by which assessments can be made. Insight gathered from these efforts will allow definite decisions to be made based on sound data as to whether or not closer surveillance and/or repair of the structure might be required to reduce its chances of failing catastrophically. Also, the periodic inspection methods developed and validated for these structures may be used to gain insight into other Corps structures.

# References

---

- Gebert, J. A., and Hemsley, J. M. (1991). "Monitoring of jetty rehabilitation at Manasquan Inlet, New Jersey," Miscellaneous Paper CERC-91-8, U.S. Army Engineer Waterways Experiment Station, Vicksburg, MS.
- Merrifield, E. M. (1974). "General discussion of dolos armor units," Frederic R. Harris Consulting Engineers, New York.
- Shore Protection Manual*. (1984). 4th ed., 2 Vol, U.S. Army Engineer Waterways Experiment Station, U.S. Government Printing Office, Washington, DC.
- Smith, E. R. (1988). "Case histories of Corps breakwater and jetty structures; Report 5, North Atlantic Division," Technical Report REMR-CO-3, U.S. Army Engineer Waterways Experiment Station, Vicksburg, MS.
- U.S. Army Engineer District, Philadelphia. (1978). "Manasquan River, Ocean and Monmouth Counties, New Jersey, rehabilitation of north and south jetties," Design Memorandum No. 3, Philadelphia, PA.

# REPORT DOCUMENTATION PAGE

Form Approved  
OMB No. 0704-0188

Public reporting burden for this collection of information is estimated to average 1 hour per response, including the time for reviewing instructions, searching existing data sources, gathering and maintaining the data needed, and completing and reviewing the collection of information. Send comments regarding this burden estimate or any other aspect of this collection of information, including suggestions for reducing this burden, to Washington Headquarters Services, Directorate for Information Operations and Reports, 1215 Jefferson Davis Highway, Suite 1204, Arlington, VA 22202-4302, and to the Office of Management and Budget, Paperwork Reduction Project (0704-0188), Washington, DC 20503.

<b>1. AGENCY USE ONLY (Leave blank)</b>		<b>2. REPORT DATE</b> December 1995	<b>3. REPORT TYPE AND DATES COVERED</b> Report 1 of a series	
<b>4. TITLE AND SUBTITLE</b> Periodic Inspection of Jetties at Manasquan Inlet, New Jersey; Report 1, Armor Unit Monitoring for Period 1984-1994			<b>5. FUNDING NUMBERS</b>	
<b>6. AUTHOR(S)</b> Robert R. Bottin, Jr., Jeffrey A. Gebert				
<b>7. PERFORMING ORGANIZATION NAME(S) AND ADDRESS(ES)</b> U.S. Army Engineer Waterways Experiment Station, 3909 Halls Ferry Road, Vicksburg, MS 39180-6199; U.S. Army Engineer District, Philadelphia, 100 Penn Square East, Philadelphia, PA 19107-3390			<b>8. PERFORMING ORGANIZATION REPORT NUMBER</b> Technical Report CERC-95-19	
<b>9. SPONSORING/MONITORING AGENCY NAME(S) AND ADDRESS(ES)</b> U.S. Army Corps of Engineers Washington, DC 20314-1000			<b>10. SPONSORING/MONITORING AGENCY REPORT NUMBER</b>	
<b>11. SUPPLEMENTARY NOTES</b> Available from National Technical Information Service, 5285 Port Royal Road, Springfield, VA 22161.				
<b>12a. DISTRIBUTION/AVAILABILITY STATEMENT</b> Approved for public release; distribution is unlimited.			<b>12b. DISTRIBUTION CODE</b>	
<b>13. ABSTRACT (Maximum 200 words)</b> <p>Under the Periodic Inspections work unit of the Monitoring Completed Coastal Projects Program, precise locations of dolos armor units on the Manasquan Inlet, New Jersey, jetty heads were established and compared with data obtained previously. The vertical and horizontal positions of the dolos were defined through limited ground surveys, low-altitude aerial photography, and photogrammetric analysis. Broken dolos armor units also were documented. Even though horizontal and vertical movements have occurred, the jetties appear to be in good structural condition and are functioning as intended. There are areas at the heads of each structure that require additional dolosse to maintain the design cross section. The site will be revisited periodically in the future and the long-term response of the breakwater to its environment will be tracked. These periodic data sets are used to improve knowledge in design, construction, and maintenance of the existing structure as well as proposed future coastal projects.</p>				
<b>14. SUBJECT TERMS</b> Aerial photography      Manasquan Inlet, New Jersey Armor units              Periodic inspections Breakwaters              Photogrammetry Dolosse                    Remote sensing			<b>15. NUMBER OF PAGES</b> 75	
			<b>16. PRICE CODE</b>	
<b>17. SECURITY CLASSIFICATION OF REPORT</b> UNCLASSIFIED	<b>18. SECURITY CLASSIFICATION OF THIS PAGE</b> UNCLASSIFIED	<b>19. SECURITY CLASSIFICATION OF ABSTRACT</b>	<b>20. LIMITATION OF ABSTRACT</b>	

Destroy this report when no longer needed. Do not return it to the originator.