

ARMY RESEARCH LABORATORY



Zero-Cost Electromagnetically Transparent Fluid Controlled Electrical Switch

by Vincent J. Ellis

ARL-TN-61

January 1996

19960220 003

DTIC QUALITY INSPECTED 1

The findings in this report are not to be construed as an official Department of the Army position unless so designated by other authorized documents.

Citation of manufacturer's or trade names does not constitute an official endorsement or approval of the use thereof.

Destroy this report when it is no longer needed. Do not return it to the originator.

REPORT DOCUMENTATION PAGE			<i>Form Approved OMB No. 0704-0188</i>		
Public reporting burden for this collection of information is estimated to average 1 hour per response, including the time for reviewing instructions, searching existing data sources, gathering and maintaining the data needed, and completing and reviewing the collection of information. Send comments regarding this burden estimate or any other aspect of this collection of information, including suggestions for reducing this burden, to Washington Headquarters Services, Directorate for Information Operations and Reports, 1215 Jefferson Davis Highway, Suite 1204, Arlington, VA 22202-4302, and to the Office of Management and Budget, Paperwork Reduction Project (0704-0188), Washington, DC 20503.					
1. AGENCY USE ONLY (Leave blank)		2. REPORT DATE January 1996	3. REPORT TYPE AND DATES COVERED Final, February 1995		
4. TITLE AND SUBTITLE Zero-Cost Electromagnetically Transparent Fluid Controlled Electrical Switch			5. FUNDING NUMBERS PE: 62120		
6. AUTHOR(S) Vincent J. Ellis					
7. PERFORMING ORGANIZATION NAME(S) AND ADDRESS(ES) U.S. Army Research Laboratory Attn: AMSRL-WT-ND 2800 Powder Mill Road Adelphi, MD 20783-1197			8. PERFORMING ORGANIZATION REPORT NUMBER ARL- TN-61		
9. SPONSORING/MONITORING AGENCY NAME(S) AND ADDRESS(ES) U.S. Army Research Laboratory 2800 Powder Mill Road Adelphi, MD 20783-1197			10. SPONSORING/MONITORING AGENCY REPORT NUMBER		
11. SUPPLEMENTARY NOTES AMS code: 622120.1400011 ARL Proj: 5FE425					
12a. DISTRIBUTION/AVAILABILITY STATEMENT Approved for public release; distribution unlimited.			12b. DISTRIBUTION CODE		
13. ABSTRACT (Maximum 200 words) A remote fluidic controlled electric switch adaptation is disclosed. The adaptation is electromagnetically transparent and material costs are near zero. An electric switch, containing mechanically operated contacts, is modified by a flexible diaphragm secured next to the switch's mechanical contacts via uses an electromagnetically transparent housing. Pressurized fluid, either liquid or gas, enters the housing and inflates the diaphragm. This exerts positive pressure on the electric switch's mechanical contact and causes the electrical contacts to close, turning the switch on. Releasing applied fluidic pressure allows the diaphragm to relax, causing the switch to turn off. Adaptation materials are electromagnetically transparent for use in electromagnetic experimentation and cost less than 1 percent of the cost of the electrical switch to which the adaptation is applied.					
14. SUBJECT TERMS Fluidic switch			15. NUMBER OF PAGES 12		
			16. PRICE CODE		
17. SECURITY CLASSIFICATION OF REPORT Unclassified	18. SECURITY CLASSIFICATION OF THIS PAGE Unclassified	19. SECURITY CLASSIFICATION OF ABSTRACT Unclassified	20. LIMITATION OF ABSTRACT UL		

Contents

1. Background	5
2. Introduction	6
3. Discussion	6
4. Detailed Description	6
5. Performance	9
6. Conclusion	9
Distribution	11

Figures

1. Zero-cost PVC adaptation	7
2. 90° variation of PVC adaptation	8
3. Spring-biased variation	8
4. Machined Plexiglas™ housing	8
5. Bolt-on nipple variation	9

1. Background

Remotely operated switches are constructed to use liquids, gas, light, electromagnetic (EM) radiation or sound as the control link. All these switches use pressure, above and/or below ambient, as the switching signal: fluid, radiation, or sound pressure. Remote switching is commonly used to energize systems under test where the test volume and instrumentation command and control are physically isolated.

During the testing of a battery-operated system's response to an EM stimulus (such as EM interference studies, radiated susceptibility studies, etc), the system's power is turned on and off remotely, to conserve battery charge. Remote switching often requires modification of the system's original power supply with at least a switch and a remote-control receiver. The size and configuration of such a modification are of concern, but more so is the effect of this modification on the system's EM coupling characteristics.

Differences in systems to be tested often require specialized remote-switch design to accommodate size, weight, and power requirements of the system. Therefore, the remote switch must be easy to modify or cost effective to reproduce.

Today's switches are wholly or partially inadequate for EM testing. Redesigning, modifying, or producing this type of switch is often expensive; furthermore, the switch often has a high metallic content. These switches often require expensive support hardware, e.g., the remote transmitter, receiver, or communication link. Switches controlled by a radio frequency (rf) control link are not compatible with EM testing because of interference. Hard-wired switches are not adequate since the metallic wires can corrupt the EM coupling characteristics of the system to which they are attached. Fiber-optic/light-controlled switches are compatible with EM testing; however, an electronic transmitter, receiver, and fiber link are required and must be designed for each system's power requirements. The fiber-optic receiver embedded in the test system adds some metal to the system, in addition to that in the electrical switch, and can be susceptible to the EM test fields and therefore unable to function properly. Liquid-pressure switches are compatible if the liquid is nonconductive; however, complications of leakage are an unacceptable risk. Air-operated pressure switches can be quite compatible with EM testing; however, to date air-operated switches have been rather large and made of metallic components or casings.

Some switches may be difficult to convert to different electrical switch types, e.g., single-pole double throw, double-pole double throw, etc. In fact, many available switches are switch designs themselves and not modifications of existing off-the-shelf switches.

2. Introduction

The switch adaptation described here was specifically developed to remotely switch battery-operated systems that are to undergo EM-susceptibility testing. Over the years, many types of remote switching have been used that range widely in cost and complexity. The switches are not intended as end items and are usually removed following the susceptibility tests. Also, a remote switch designed for one system may not be adequate for another system because of different power requirements, size, configuration, and so forth.

The goal of the present adaptation was to develop an inexpensive, electromagnetically transparent remote-control switch that could be easily modified and used in a wide range of systems. Since most test facilities have compressed air drops (pressure source), air lines (control link), and regulators at or near their instrumentation control room, air-operated switches are portable and inexpensive. The task, then, was to design a nonmetallic air-pressure receiver and couple the receiver to off-the-shelf electrical switches.

Although the adaptation described is simple, it allows for remote switching of experimental test systems with near zero-cost, maximum EM compatibility, and maximum configurational flexibility.

3. Discussion

The switch design has an electromagnetically transparent housing rigidly mounted on an electrical switch. An electromagnetically transparent nipple is then rigidly attached to the housing near the switch's mechanical actuator at one end and accepts a fluidic conduit at the opposite end. Located between this housing and nipple connection, an electromagnetically transparent flexible diaphragm is fixed and sealed to the nipple so that, together, the nipple and diaphragm form a fluid-tight reservoir. As fluidic pressure, preferably supplied by a compressed-air source, is applied to the nipple via a fluidic conduit, the diaphragm will expand under pressure, exerting pressure on the electrical switch's actuator. Given sufficient fluidic pressure, the electrical switch's contacts will then switch states.

4. Detailed Description

Figure 1 shows the adaptation in its simplest, least expensive construction. A housing made of a PVC tube (3/8 in. I.D., 1/2 in. O.D.) is shown mounted on a momentary push-button electrical microswitch. The housing can be mounted with a nylon bolt and nut or with adhesive or other suitable means. The nipple, a PVC tube (1/4 in. I.D., 3/8 in. O.D.), is fitted inside the housing, positioned directly in line with the switch's mechanical actuator. A flexible diaphragm, the fingertip of a latex glove, is positioned and pressure-fitted between the inside walls of the housing and the out-

side wall of the nipple. The nipple can be affixed to the housing with a bead of adhesive around the housing/nipple seam. A flat plate is placed between the diaphragm and the switch's actuator within the housing. The plate helps to distribute the leading edge of the expanding diaphragm and prevent pinching. The pressure plate can be cut from a sheet of Plexiglas™, plastic, or other suitable dielectric. The portion of the nipple that protrudes from the housing accepts a fluidic conduit (air line and hose clamp), which transfers fluidic pressure to the interior of the nipple.

Figure 2 shows a variation where the nipple is arranged at 90° to the housing. This design is slightly more compact than that in figure 1, but it requires higher fluidic input pressure to operate. Figure 3 is a variation where a spring located between the switch body and the pressure plate can be used to adjust the operating fluidic pressure.

Figures 4 and 5 depict stronger and more durable, but costlier, variations in which the housing is machined from rigid square stock such as Plexiglas™, acrylic, or any suitable plastic.

Figure 1. Zero-cost PVC adaptation.

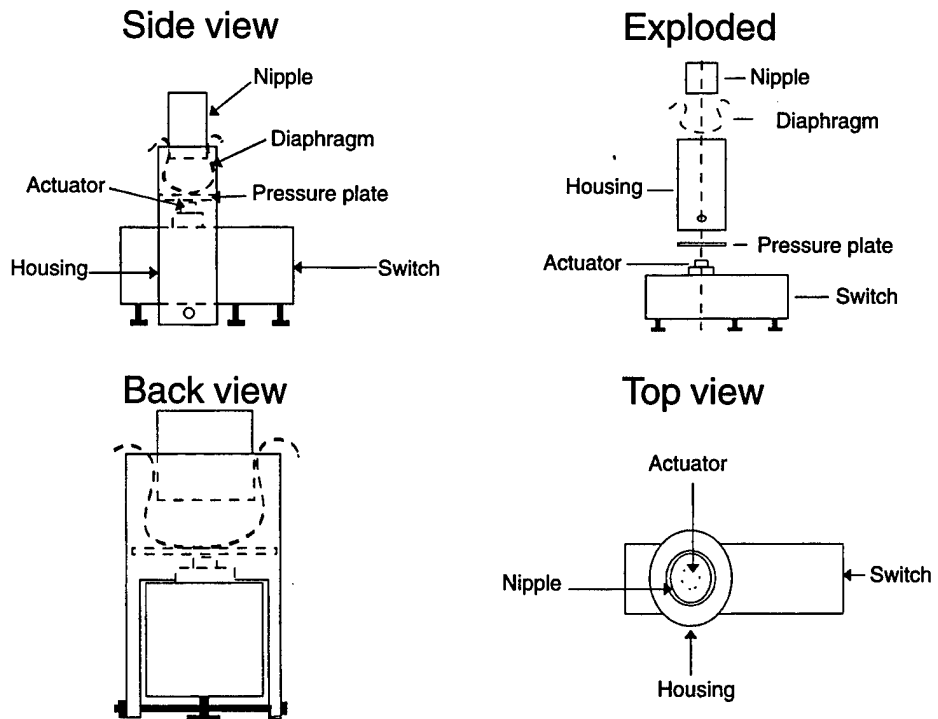

Figure 2. 90° variation of PVC adaptation.

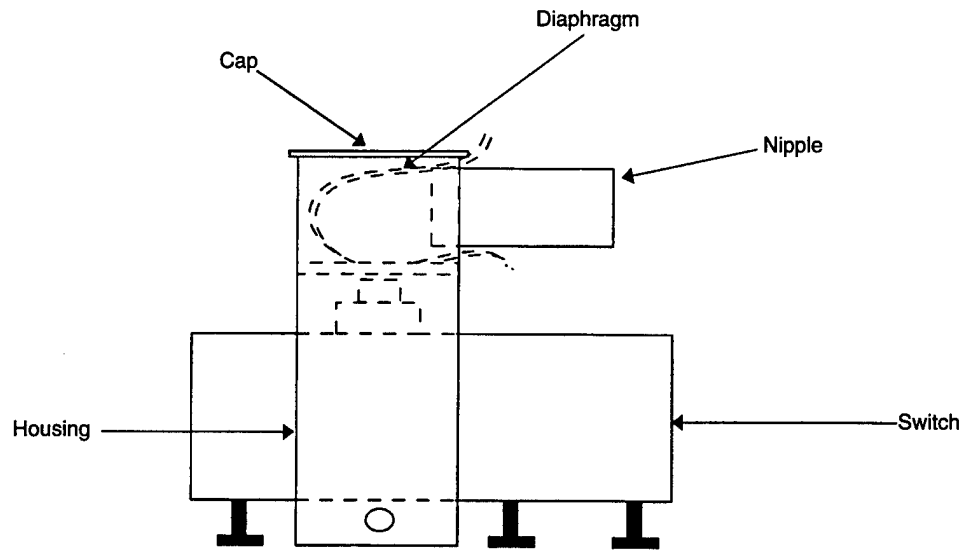

Figure 3. Spring-biased variation.

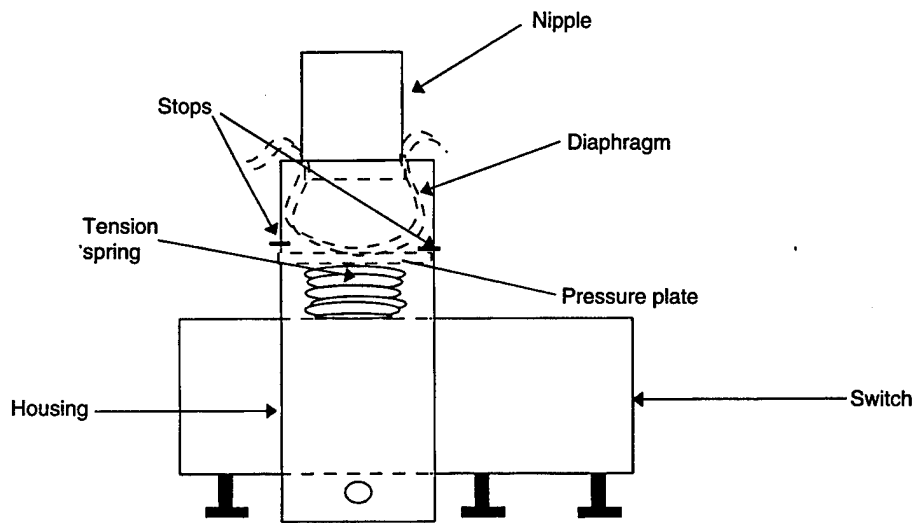

Figure 4. Machined Plexiglas™ housing (a) with upright nipple and (b) with 90° nipple.

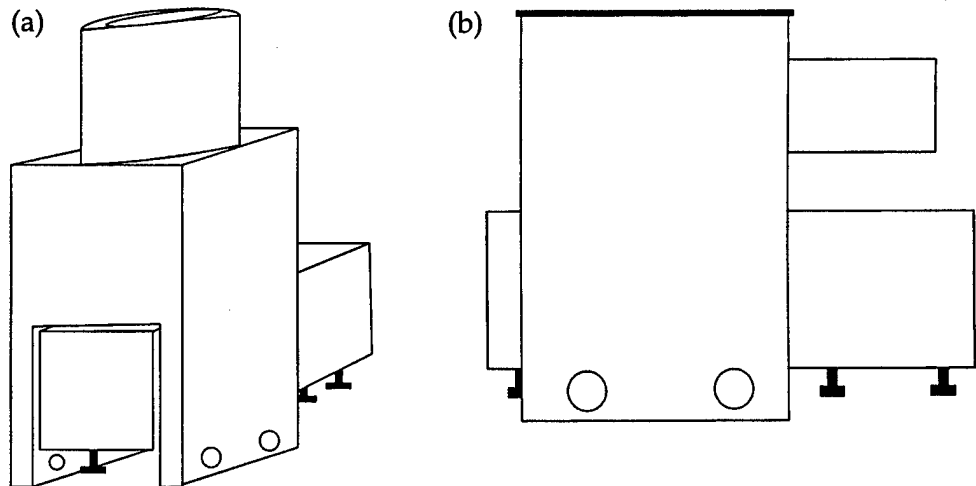
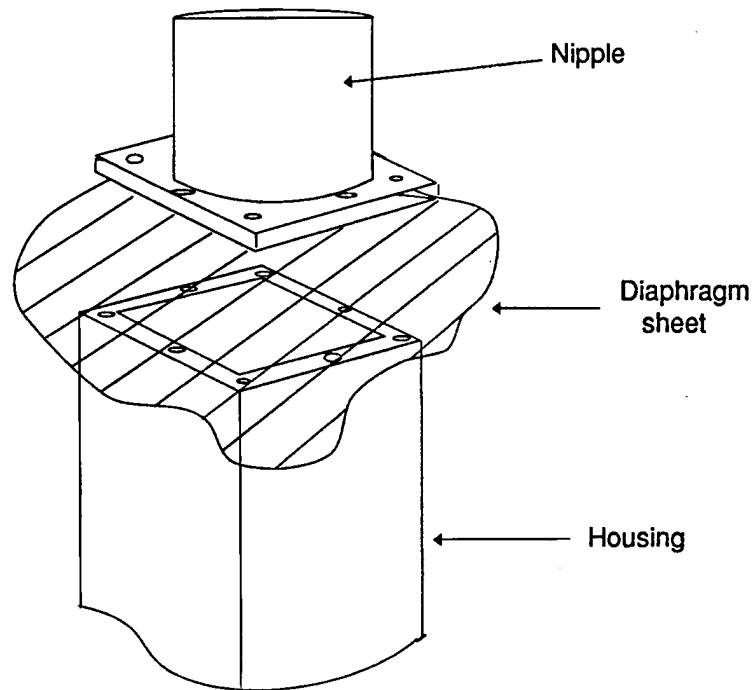

Figure 5. Bolt-on nipple variation.



5. Performance

Repeated cycling tests of the first prototype constructed (fig. 1) show that the switch operates reliably with turn-on pressure of >8 psi and turn-off pressure of <4 psi. The second prototype (fig. 2) operated reliably at >34 psi (turn-on) and <23 psi (turn-off). The switches experienced significant chatter between on and off pressures. Because of this chatter, the switches should be operated digitally (off/on) rather than allowing prolonged in-pressure between the on/off pressures.

The adaptations disclosed here are constructed rather crudely; therefore, each switch must be characterized for operating pressure before being implanted in a system. To duplicate switches in quantity, one could use the spring-biased variation of figure 3 to produce switches with the desired operating pressure. A spring can be chosen for each switch so that common operating pressures are achieved. Alternatively, if the travel distance of the pressure plate is changed, the fluidic force (pressure) required to compress the spring and engage the switch can be varied.

6. Conclusion

A reliable adaptation of electric switches for remote fluidic control has been demonstrated. Any electric switch may be adapted to fluidic control through the addition of dielectric materials. A switch can be configured from PVC for near-zero cost. The adaptation may be applied to any switch type and can be adjusted for shape, size, and configurational variations.

The switches are ideal for experimental use, such as powering battery-operated systems or instrumentation for EM-interference studies.

Preliminary cycling tests performed on two switches indicate that this type of switch is reliable. However, comprehensive switch life tests have not yet been performed and would be required before production.

Distribution

Admnstr
Defns Techl Info Ctr
Attn DTIC-DDA (2 copies)
8725 John J. Kingman Rd Ste 0944
FT Belvoir VA 22060-6218

Ofc of the Secy of Defs
Attn ODDRE (R&AT) S Gontarek
The Pentagon
Washington DC 20301-3080

Army Matl Comnd
Attn AMCRD-AR G Aveta
Attn AMCDE-PQI J Kreck
5001 Eisenhower Ave
Alexandria VA 22333-0001

Belvoir Rsrch Dev & Engrg Ctr
Attn STRBE-NA S Schaedel
FT Belvoir VA 22060-5606

Hdqtr US Army Cmmctn-Elect Cmnd RD&E
CTR Night Vsn & Elect Sensors Dirctr
Attn AMSEL-RD-NV-ADS M Kovach
FT Monmouth NJ 07703-5206

HQ Dept of the Army
Attn DAMO-FDQ MAJ M McGonagle
400 Army Pentagon
Washington DC 20310-0460

Ofc of the Assist Scy of the Army for Rsrch
Dev & Acqstn
Attn SARD-TT F Milton Rm 3E479
Attn SARD-TT C Nash Rm 3E479
The Pentagon
Washington DC 20310-0103

US Army CECOM Intlgn/Elect Warfare
Dirctr
Attn AMSEL-RD-IEW-SPO D Helm
Vint Hill Farms Sta
Warrenton VA 22186-5100

US Army Mis Cmnd
Attn AMSMI-RD-WS-UB D Holder
Bldg 4500-West
Redstone Arsenal AL 35898-5248

US Army Rsrch Lab
Attn AMSRL-OP-SD-TA Mail & Records
Mgmt
Attn AMSRL-OP-SD-TI Tech Library
(3 copies)
Attn AMSRL-OP-SD-TP Tech Pub
Attn AMSRL-WT-NA R A Kehs
Attn AMSRL-WT-ND J Miletta
Attn AMSRL-WT-NF L Jasper
Attn AMSRL-WT-NH J Corrigan
Attn AMSRL-WT-NH V Ellis (10 copies)
Adelphi, MD 20783-1197