



**US Army Corps
of Engineers**
Waterways Experiment
Station

Miscellaneous Paper IRRP-95-2
October 1995

Installation Restoration Research Program

Bioremediation of Soils Contaminated with Petroleum Hydrocarbons Using Bioslurry Reactors

by *Shankha K. Banerji, University of Missouri*

*Mark E. Zappi, Cynthia L. Teeter, Douglas Gunnison,
M. John Cullinane, Robert T. Morgan, WES*

DTIC QUALITY INSPECTED 4

DTIC QUALITY INSPECTED 4

Approved For Public Release; Distribution Is Unlimited

19960213 071

Prepared for Headquarters, U.S. Army Corps of Engineers

The contents of this report are not to be used for advertising, publication, or promotional purposes. Citation of trade names does not constitute an official endorsement or approval of the use of such commercial products.



PRINTED ON RECYCLED PAPER

Bioremediation of Soils Contaminated with Petroleum Hydrocarbons Using Bioslurry Reactors

by Shankha K. Banerji

Department of Civil Engineering
University of Missouri
Columbia, MO 65211

Mark E. Zappi, Cynthia L. Teeter, Douglas Gunnison,
M. John Cullinane, Robert T. Morgan

U.S. Army Corps of Engineers
Waterways Experiment Station
3909 Halls Ferry Road
Vicksburg, MS 39180-6199

Final report

Approved for public release; distribution is unlimited



**US Army Corps
of Engineers**
Waterways Experiment
Station

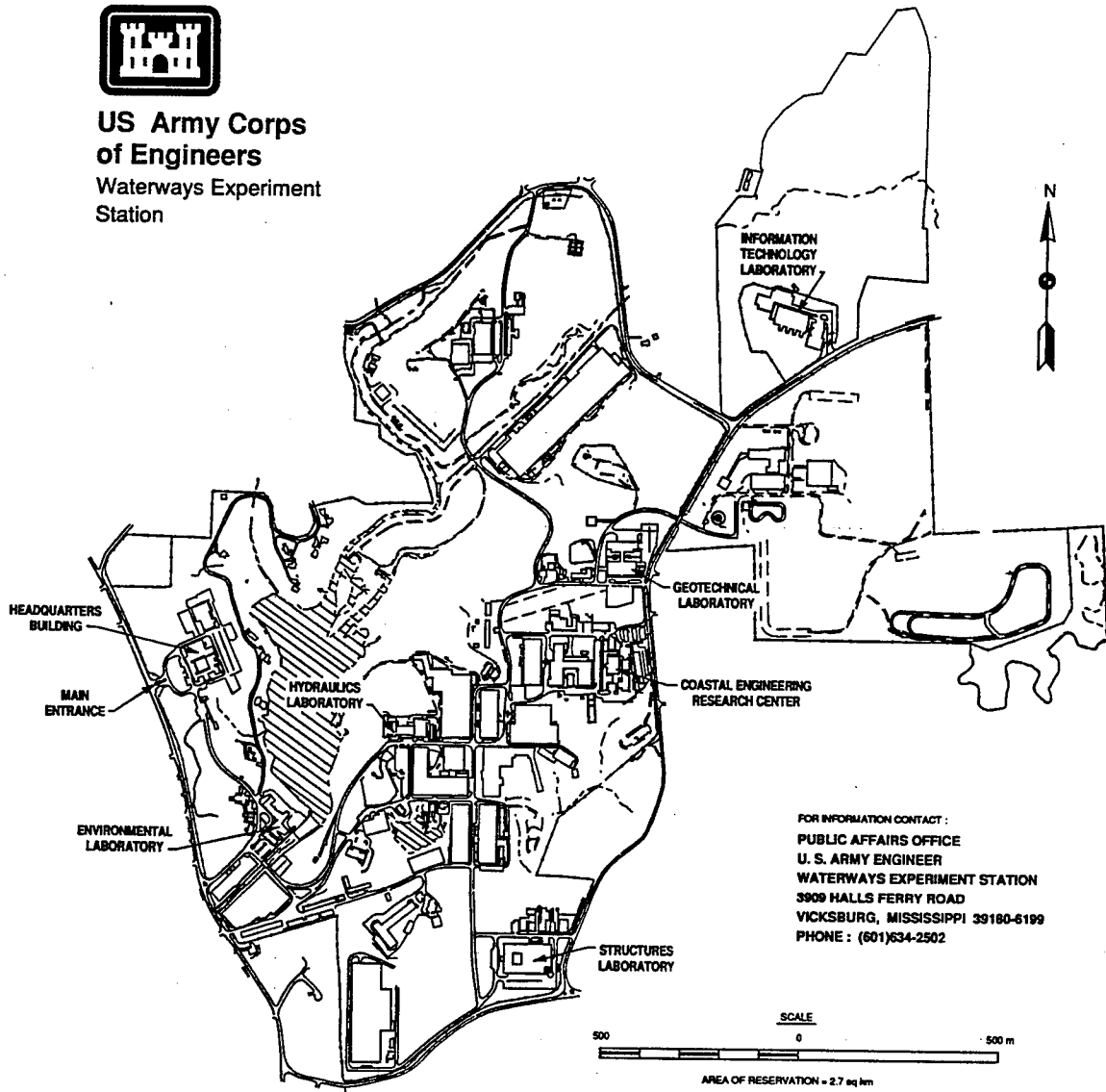

FOR INFORMATION CONTACT :
PUBLIC AFFAIRS OFFICE
U. S. ARMY ENGINEER
WATERWAYS EXPERIMENT STATION
3909 HALLS FERRY ROAD
VICKSBURG, MISSISSIPPI 39180-6199
PHONE : (601)634-2502

Waterways Experiment Station Cataloging-in-Publication Data

Bioremediation of soils contaminated with petroleum hydrocarbons using bioslurry reactors / by Shankha K. Banerji ... [et al.] ; prepared for U.S. Army Corps of Engineers. 75 p. : ill. ; 28 cm. -- (Miscellaneous paper ; IRRP-95-2)

Includes bibliographic references.

1. Soil remediation. 2. Bioremediation. 3. Oil pollution of soils. I. Banerji, Shankha K.
- II. United States. Army. Corps of Engineers. III. U.S. Army Engineer Waterways Experiment Station. IV. Installation Restoration Research Program. V. Series: Miscellaneous paper (U.S. Army Engineer Waterways Experiment Station) ; IRRP-95-2. TA7 W34m no.IRRP-95-2

Contents

Preface	vii
Conversion Factors, Non-SI to SI Units of Measurement	viii
1—Introduction	1
2—Literature Review and Background Information	4
Petroleum Hydrocarbon Aerobic Biodegradation	4
Factors Affecting Biodegradation of Petroleum Hydrocarbons	8
Bioslurry Process	10
3—Bench- and Pilot-Scale Evaluations	12
Ninth Avenue Dump Superfund Site, Bench-Scale Evaluation	12
Ninth Avenue Dump Superfund Site, Pilot-Scale Evaluation	21
Fort Sheridan Site, Bench-Scale Evaluation	27
Fort Sheridan Site, Pilot-Scale Evaluation	37
Summary	47
4—Design and Cost Estimates	48
Process Concepts	48
Process Design	50
Cost Estimates	53
References	58
Appendix A: Design Calculations	A1
Appendix B: Labor and Energy Requirements for the Options Considered	B1

SF 298

List of Figures

Figure 1. Naphthalene biodegradation pathway	7
Figure 2. Bench-scale bioslurry reactor—TPH removals in different reactors, Ninth Avenue Dump Superfund Site	15

Figure 3.	Bench-scale bioslurry reactor—PID data, Ninth Avenue Dump Superfund Site	15
Figure 4.	Bench-scale bioslurry reactor—total BTEX removals, Ninth Avenue Dump Superfund Site	16
Figure 5.	Bench-scale bioslurry reactor—total PAH removals, Ninth Avenue Dump Superfund Site	17
Figure 6.	Bench-scale bioslurry reactor—OUR data, Ninth Avenue Dump Superfund Site	18
Figure 7.	Bench-scale bioslurry reactor—ammonia data, Ninth Avenue Dump Superfund Site	18
Figure 8.	Bench-scale bioslurry reactor—microorganisms recovered on basal salts agar with fluorene, Ninth Avenue Dump Superfund Site	19
Figure 9.	Bench-scale bioslurry reactor—microorganisms recovered on basal salts agar with ethylbenzene, Ninth Avenue Dump Superfund Site	20
Figure 10.	Bioslurry reactor used for pilot-scale tests	22
Figure 11.	Bioslurry reactor gas recirculation system	22
Figure 12.	Bench-scale bioslurry reactor—microorganisms recovered on basal salt agar with toluene fumes, Fort Sheridan site	35
Figure 13.	Bench-scale bioslurry reactor—microorganisms recovered on basal salt agar with phenanthrene fumes, Fort Sheridan site	36
Figure 14.	Modified bioslurry reactor with foam-breaker features	38
Figure 15.	Pilot-scale bioslurry reactor—microorganisms recovered on PTYG agar, Fort Sheridan site	45
Figure 16.	Pilot-scale bioslurry reactor—microorganisms recovered on basal salt agar with phenanthrene fumes, Fort Sheridan site	45
Figure 17.	Pilot-scale bioslurry reactor—microorganisms recovered on basal salt agar with toluene fumes, Fort Sheridan site	46
Figure 18.	Schematic of bioslurry process for remediating contaminated soil	49

List of Tables

Table 1.	Operating Conditions for Bench-Scale Bioslurry Reactors, Ninth Avenue Dump Superfund Site	13
Table 2.	Pilot-Scale Bioslurry Reactors—TPH Concentrations (mg/L), Ninth Avenue Dump Superfund Site	24
Table 3.	Pilot-Scale Bioslurry Reactors—PAH Removals, Ninth Avenue Dump Superfund Site	26
Table 4.	Pilot-Scale Bioslurry Reactor Study—Average Concentrations of Aqueous Phase PAH Compounds in Treated Soil Slurry, Ninth Avenue Dump Superfund Site	26
Table 5.	Bench-Scale Bioslurry Reactor Study—Treatment Alternatives, Fort Sheridan Site	28
Table 6.	Bench-Scale Bioslurry Reactor Study—TPH Data (mg/kg), Fort Sheridan Site	29
Table 7.	Bench-Scale Bioslurry Reactor Study—PID Readings, Fort Sheridan Site	30
Table 8.	Bench-Scale Bioslurry Reactor Study—Volatile Compounds Data, Soil Slurry, Fort Sheridan Site	31
Table 9.	Bench-Scale Bioslurry Reactor Study—PAH Compounds Data, Fort Sheridan Site	32
Table 10.	Pilot-Scale Reactor Study—TPH Removal in Soil (mg/kg), Fort Sheridan Site	39
Table 11.	Pilot-Scale Bioslurry Reactor Study—TPH Removal in Aqueous Phase (mg/L), Fort Sheridan Site	39
Table 12.	Pilot-Scale Bioslurry Reactor Study—Soil Phase Volatile Compounds Data (mg/kg), Fort Sheridan Site	40
Table 13.	Pilot-Scale Bioslurry Reactor Study—Aqueous Phase Volatile Compounds Data (mg/L), Fort Sheridan Site	42
Table 14.	Pilot-Scale Bioslurry Reactor Study—Soil Phase PAH Compounds Data (mg/kg), Fort Sheridan Site	43
Table 15.	Pilot-Scale Bioslurry Reactor Study—Reactor Operating Data, Fort Sheridan Site	44
Table 16.	Alternative 1: Costs for Bioslurry Treatment of Contaminated Soils	55
Table 17.	Alternative 2: Costs for Bioslurry Treatment of Contaminated Soils	57

Table B1.	Labor and Energy Requirements for Cascading Reactors with Centrifuge Dewatering Option	B1
Table B2.	Labor and Energy Requirements for Single Reactor with Sand Drying Bed Option	B2

Preface

The work reported herein was conducted by the U.S. Army Engineer Waterways Experiment Station (WES) as part of the Installation Restoration Research Program (IRRP) and the U.S. Army Environmental Quality Technology Research Program. Dr. Clem Meyer was the IRRP Coordinator at the Directorate of Research and Development, Headquarters, U.S. Army Corps of Engineers.

This report was prepared by Dr. Shankha K. Banerji, Professor, Department of Civil Engineering, University of Missouri, Columbia, MO; Drs. Mark E. Zappi, Douglas Gunnison, and M. John Cullinane; CAPT Robert T. Morgan; and Ms. Cynthia L. Teeter, Environmental Restoration Branch, Environmental Laboratory (EL), WES.

The authors wish to thank Mr. Michael R. Burchell for his insight and assistance in the preparation of this report.

This work was conducted under the supervision of Mr. Norman Francingues, Chief, Environmental Engineering Division, and Dr. John W. Keeley, Director, EL.

At the time of publication of this report, Director of WES was Dr. Robert W. Whalin. Commander was COL Bruce K. Howard, EN.

This report should be cited as follows:

Banerji, S. K., Zappi, M. E., Teeter, C. L., Gunnison, D., Cullinane, M. J., and Morgan, R. T. (1995). "Bioremediation of soils contaminated with petroleum hydrocarbons using bioslurry reactors," Miscellaneous Paper IRRP-95-2, U.S. Army Engineer Waterways Experiment Station, Vicksburg, MS.

The contents of this report are not to be used for advertising, publication, or promotional purposes. Citation of trade names does not constitute an official endorsement or approval of the use of such commercial products.

Conversion Factors, Non-SI to SI Units of Measurement

Non-SI units of measurement used in this report can be converted to SI units as follows:

Multiply	By	To Obtain
cubic feet	0.2831685	cubic meters
cubic yards	0.7645549	cubic meters
feet	0.3048	meters
gallons (U.S. liquid)	0.003785412	cubic meters
horsepower (550 foot-pounds force per second)	745.6999	watts
pounds (mass) per cubic foot	16.01846	kilograms per cubic meter
inches	0.0254	meters
square feet	0.09290304	square meters
tons (2,000 pounds, mass)	907.1847	kilograms

1 Introduction

Contamination of the environment by petroleum hydrocarbons has occurred naturally since prehistoric times, but in recent years man-made oil (petroleum hydrocarbon) spills have become quite common. It is estimated that about 6 million tons¹ of oil enter the environment each year (Brown 1987). The environmental damage from such contamination may be quite serious in some instances, e.g., Alaska oil spill by Exxon Valdez in 1989.

The environmental damage from petroleum hydrocarbon spills depends upon the type of products involved. It could be crude oil or refined petroleum products. Crude oil may contain thousands of diverse chemical compounds including dissolved gases, liquids, and bituminous solids, while refined petroleum products are usually a mixture of defined chemical compounds. Thus, for remediating spills from oil products it is important to determine the chemical compounds involved.

Compounds in petroleum hydrocarbons can be separated into the following categories:

- a. Saturated fraction-comprising n-alkanes, branched alkanes, and cyclic alkanes which are all aliphatic compounds.
- b. Aromatic and substituted aromatic compounds such as benzene and toluene.
- c. Polycyclic aromatic compounds such as naphthalene, phenanthrene, and benzo(a)pyrene.
- d. Polar compounds consisting of nitrogen- (N), sulfur- (S), and oxygen- (O) containing substituents, e.g., phenols, pyridine, thiopene, etc.
- e. Asphaltic residues consisting of very large complex molecules.

¹ A table of factors for converting non-SI units of measurement to SI units is presented on page viii.

Refined petroleum products contain few asphaltic residues, but may have alkenes or unsaturated aliphatics, among other compounds, formed during the "cracking" process (Bartha 1986).

Oil spills have quite different fates in water and on land. In water, oil, being an immiscible liquid, spreads out over a large area in the form of a thin film depending on the wind, water temperature, and oil viscosity. On land, petroleum hydrocarbons infiltrate vertically downward through the unsaturated soil until they reach the water table where they spread laterally. This report concerns the remediation of petroleum hydrocarbon spills on land.

The environmental fate of compounds present in petroleum hydrocarbon spills on land depends on the type of products spilled. Rapid infiltration through the soil reduces the evaporative and photodegradative losses of the compounds present. Evaporative and photodegradative losses of petroleum hydrocarbons are estimated to be only 1 to 2 percent in terrestrial oil spills (Bartha 1986). The hydrophobic nature of petroleum hydrocarbons causes surface absorption and retention on soil particles, minimizing the rate and extent of movement of these compounds. In aerobic soils, petroleum hydrocarbons are biodegraded by native microbes, especially under favorable temperature and moisture conditions. In deeper strata, lack of oxygen, nutrients, and favorable biota reduces the biodegradation of these compounds.

Some of the available methods to remediate soils contaminated with petroleum hydrocarbons include in situ techniques (including land-farming (bioremediation), vapor extraction, or soil venting) and techniques involving soil excavation (such as composting, bioslurry treatment, incineration).

One drawback of the vapor extraction process is that volatile and some semivolatile compounds present in the solid phase (soil) are transferred to the vapor phase. They then require treatment by activated carbon absorption or catalytic combustion before release. The cost of this process is relatively high compared to other options. The same drawback holds for the incineration process where the contaminated soil must be excavated and conveyed to the incinerator.

The three biological processes (in situ land farming, composting, and bioslurry treatment) all have relatively low costs compared to the other alternative processes, but the performance, environmental consequences, and treatment time of these processes vary widely.

The in situ land-farming process is most applicable to contaminated surface soils, or it could be applied to deeper soil layers provided they are excavated and spread over a prepared surface. This process involves the addition of appropriate amounts of moisture and nutrients (nitrogen (N), phosphorus (P), and potassium (K)) to the contaminated soil and regularly tilling it to provide O₂. The indigenous microbial population in the soil degrades some of the petroleum hydrocarbons present. There are disadvantages to this process: slow treatment kinetics (especially in colder climates), a large amount of

surface area required, it may cause groundwater contamination if a liner is not installed underneath, and it may cause emission of volatile components if not controlled. Some of the drawbacks mentioned above can be corrected by removing the contaminated soil from the site, stockpiling it, lining the area with an appropriate liner, respreading the soil in 15- to 20-in. layers on the site, covering the soil with a plastic film to collect the volatile emissions for treatment, and following other land-farming procedures as outlined previously (Borquin 1989). This type of operation increases the cost of the operation markedly but does not improve the slow kinetics, nor does it reduce the area requirement.

In the composting process, contaminated soil is mixed with appropriate inert bulking materials (e.g., stray wood chips) and piled in a windrow mound which is periodically turned over to maintain aerobic conditions. Moisture and nutrient levels are maintained at an optimal level by using irrigation techniques. Leachate control can be instituted by lining the bottom of the mounds and by using a proper enclosure. Volatile emissions can be captured for further treatment. Conservation of heat during aerobic oxidation of degradable organics inside the soil mounds can increase the temperatures inside to the thermophilic range (-65 to 70 °C) for some period of time. The kinetics of the process are somewhat better than land farming but still relatively slow.

In the bioslurry process, excavated contaminated soil is processed to remove larger particles (>0.25 in.) and then placed in a reactor (or an onsite lined pond) to form a 10 to 40 percent by weight slurry with water. The slurry is agitated and aerated to keep the solids in suspension and to maintain aerobic conditions. Environmental conditions such as nutrients, dissolved oxygen, pH, and mixing inside the reactor are maintained at optimal levels for indigenous microbial life to biodegrade the petroleum hydrocarbon contaminants. Depending on the type of contaminants present, gaseous emissions from the reactor can be collected and treated. Some of the advantages of bioslurry processes compared to other soil bioremediation processes are better process monitoring and control, faster reaction kinetics due to increased bioavailability of the contaminants and nutrients, better control of air emissions, and a lower land area requirement. The disadvantages of the bioslurry process are: it is limited to materials that are easily dispersed in water; longer treatment times are required for wastes containing high amounts of oil and grease; the soil must be excavated; pretreatment of the soil is sometimes needed; and control of volatile emissions may be required.

The bioslurry process has the potential to treat contaminated soils and sludges from refinery wastes, wood preserving wastes, wastes containing polychlorinated biphenyls (PCBs) and halogenated volatile organics (U.S. Environmental Protection Agency (USEPA) 1990).

This report presents data from two bench-scale and two pilot-scale studies to evaluate the suitability of bioslurry processes to bioremediate petroleum-hydrocarbon-contaminated soils. Additionally, conceptual designs and costs of bioslurry processes for field applications are presented.

2 Literature Review and Background Information

A brief literature review of the biodegradation of the major components of petroleum hydrocarbons and the bioslurry process is included to provide background information.

Petroleum Hydrocarbon Aerobic Biodegradation

As indicated earlier, petroleum hydrocarbons contain many different types of organic compounds, namely alkanes (normal, iso-, and cyclo-), aromatics, polycyclic aromatics, heterocyclic, and asphaltic compounds. Each of these compounds has a different biodegradation rate in the natural environment. The chemical structure of each compound governs its biodegradation potential, but other factors such as solubility, toxicity, and interaction with other molecules present also affect the rate and extent of biodegradation (Bartha 1986).

Microorganisms (bacteria, yeasts, and fungi) that use petroleum hydrocarbons as a source of cell carbon and energy are widely distributed in nature. More than 100 strains of bacteria have been identified that degrade petroleum hydrocarbons (Foght and Westlake 1984). Some of the more common bacterial species belong to the following genera: *Pseudomonas*, *Achromobacter*, *Arthrobacter*, *Micrococcus*, *Nocardia*, *Vibrio*, *Brevibacterium*, *Corynebacterium*, and *Flavobacterium*. In an environment that is not under stress, bacteria are generally believed to be primarily responsible for the degradation of petroleum hydrocarbons. They generally are in greater numbers compared to yeasts and fungi in an environment contaminated with petroleum hydrocarbon compounds. Fungi and yeasts perform better in degrading these compounds in conditions which preclude bacterial growth (Foght and Westlake 1984).

Alkane biodegradation

Straight chain n-alkanes usually are more easily degraded compared to other hydrocarbons, but smaller chain length alkanes (C_5 to C_{10}) are inhibitory to some of the hydrocarbon degrading microorganisms. These molecules act

as a solvent disrupting the membrane structure of the cell. Intermediate chain length (C_{10} to C_{20}) degrade most readily by many microorganisms (Bartha 1986). Alkanes with longer chain length ($>C_{20}$), often referred to as "waxes," are quite hydrophobic in nature and thus degrade very slowly. Branching of the alkane chain inhibits degradation. Thus, $n-C_{17}$ and $n-C_{18}$ alkanes are easily degraded by microorganisms while their branched chain counterparts, pristane and phytane, are slow to degrade (Foght and Westlake 1984). The cyclic alkanes also degrade quite slowly. Some of the monocyclic compounds such as cyclopentane, cyclohexane, and cycloheptane have a solvent effect on the lipid membranes of microbial cells and thus are toxic to most of the hydrocarbon degrading bacteria (Perry 1984).

The primary attack on the hydrocarbon molecule in the presence of oxygen is through the action of oxygenases. The mono-oxygenase reaction with the alkane results in an alcohol product. The alcohol product is then oxidized to an aldehyde and, finally, to an acid product. The acid product can be further degraded by beta-oxidation. Presence of branching interferes with the beta-oxidation process (Bartha 1986). Cycloalkanes are susceptible to degradation by co-metabolism in the presence of other easily degradable compounds (Foght and Westlake 1984).

Biodegradation of aromatic hydrocarbon compounds

Initial aromatic hydrocarbon degradation by prokaryotic microorganisms (bacteria) is carried out by a dioxygenase enzyme system, resulting in *cis*-hydrodiols which are further oxidized to dihydroxy products. In the case of benzene the dihydroxy product is catechol (Bartha 1986). In eukaryotic microorganisms, a mono-oxygenase enzyme initially oxidizes the hydrocarbon to a 1, 2 oxide. This is followed by addition of a water molecule to yield a dihydroxy-dihydro compound, which is then oxidized to an aromatic hydrocarbon. It may be cleaved at the ortho- or the meta-position to yield muconic acid or 2-hydroxy muconic semialdehyde. These products can be metabolized to tricarboxylic acid cycle intermediates (Bartha 1986).

Many studies have evaluated biodegradation in groundwater or soils contaminated with benzene, toluene, ethylbenzene, and *o*-, *m*-, and *p*-xylene (BTEX) compounds, which are common components of gasoline (Thomas et al. 1990, Goldsmith and Balderson 1988, and Chiang et al. 1989). These compounds enter the environment either through leaky underground storage tanks or by accidental spills. Thomas et al. (1990) reported on an *in situ* bioremediation process at a site in Granger, Indiana, where a gasoline spill contaminated a shallow aquifer. Core sample data showed that toluene, ethylbenzene, and *m*-xylene were all removed by the subsurface microflora, but *o*-xylene remained. The data indicated that the biodegradation potential at the site, which was biostimulated earlier, remained enhanced 2 years after the *in situ* bioremediation process had been terminated. Goldsmith (1988) isolated bacterial strains capable of utilizing benzene, toluene, and *p*-xylene as sole carbon sources from an aged soil contaminated with gasoline. In microcosm

experiments using soil and groundwater from a gasoline-contaminated field site in Michigan, Chaing et al. (1989) found that 80 to 100 percent of the aromatic hydrocarbon (BTX) at levels of 120 to 16,000 ppb were degraded with a half life ($T_{1/2}$) of 5 to 20 days when the dissolved oxygen (DO) level was greater than 2 mg/L. The BTX degradation rate slowed down considerably when the DO levels were lower than 2 mg/L ($T_{1/2}$, 20 to 60 days).

Biodegradation of polycyclic aromatic hydrocarbons

Polycyclic aromatic hydrocarbons (PAHs) are a group of compounds having two or more fused aromatic rings in a linear, angular, or cluster arrangement. Generally, two- to three-ringed PAH compounds degrade at a relatively faster rate than PAH compounds having more than three rings. In some instances, the degradation rate of higher ringed PAHs is facilitated by the presence of other structurally related two- or three-ringed compounds (Park, Sims, and Dupont 1990). Also, higher molecular weight PAHs may be co-metabolized to simpler intermediates in the presence of supplementary carbon sources, viz. biphenyl and succinate.

The initial oxidation of a PAH by microbes follows the same route as was described earlier for aromatic hydrocarbons, i.e., the formation of *cis*-dihydrodiols by a dioxygenase which then leads to the formation of catechols (Cerniglia 1984). The catechols are substrates for other dioxygenases that cleave the aromatic ring to *cis*, *cis*-muconic acid, or 2-hydroxy muconic semialdehyde.

Figure 1 shows the pathway for naphthalene biodegradation by bacteria (Cerniglia 1984). Fungi oxidize PAHs through a mono-oxygenase and epoxide-hydrolase catalyzed step to trans-dihydrodiols (as in mammalian system), which are further degraded to simpler products (Cerniglia 1984).

Sims et al. (1989) reported on the biodegradation of PAHs in soil environments with additional carbon and energy sources, and pH adjustments from 6.1 to 7.5. The addition of amendments reduced the $T_{1/2}$ of the recalcitrant PAHs considerably compared to unamended systems, e.g., the $T_{1/2}$ for benzo(a)pyrene (B(a)P) decreased from 91 to 69 days. Thus, co-metabolism of the molecules caused a significant difference in the biodegradation rate. Sims et al. (1989) also reported that the addition of an acclimated soil microbial population in land farming can markedly increase the biodegradation rate of PAH compounds in fossil fuel wastes. A much larger percentage of PAH removal was observed in the acclimated soils in 22 days compared to unacclimated soils in 40 days. Marks et al. (1992) studied the biodegradation of petrochemical sludges containing PAH compounds. They selected B(a)P as the target contaminant in the sludge for their study, which was carried out in sealed continuous stirred reactors. The B(a)P concentrations varied from 285 to 3,475 mg/kg of dry solids. The B(a)P and other PAH removals were greater than 90 percent.

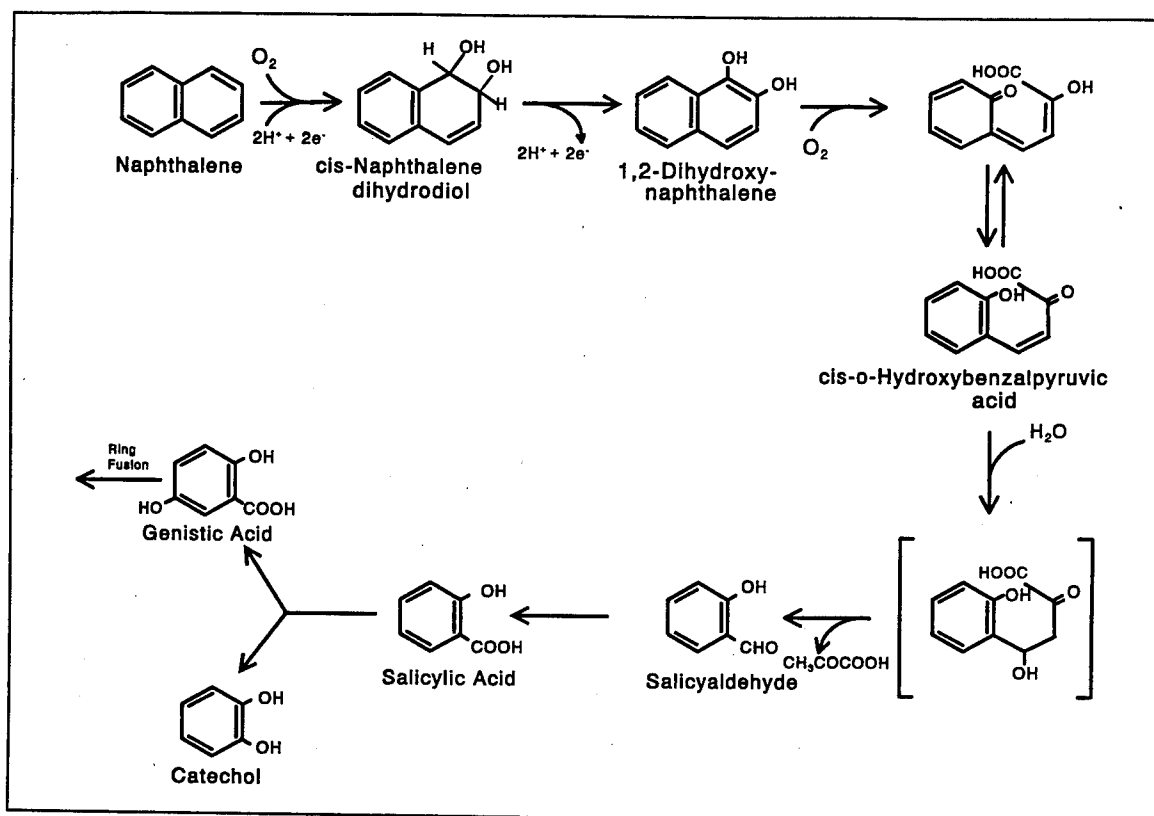

Figure 1. Naphthalene biodegradation pathway (Cernaglia 1984)

Biodegradation kinetics in unacclimated soils for 14 PAH compounds were reported by Park et al. (1990) who found significant volatilization (22 to 33 percent) of naphthalene and 1-methylnaphthalene, the two-ringed compounds. For other PAHs (three or more rings), the volatilization losses were quite small (<0.1 percent). There was some abiotic loss (1.8 to 17.4 percent) of the two- and three-ringed PAHs, but for greater than three-ringed compounds, this loss was minor. The biodegradation $T_{1/2}$'s, corrected for abiotic losses and volatilization, were about 2 days for two-ringed PAHs. For three-ringed PAHs, the $T_{1/2}$ was around 59 days but increased to more than 300 days for more than three-ring PAHs.

Biodegradation of compounds containing N, S, and O, and the asphaltic fraction

The biodegradation of compounds containing N and S and the asphaltic fraction in petroleum hydrocarbons is not well documented, partly because of the problems of analysis and complexity of these fractions (Foght and Westlake 1984). However, the biodegradation of oxygen-containing compounds, such as phenols and naphthols is well studied (Paris et al. 1982, Banerjee et al. 1984, and Deeley et al. 1985). Paris et al. (1982) studied the biodegradation of phenols by the microorganism *Pseudomonas putida*. Different structural groups on the ring affected the transformation rate of the phenols. In a similar

study, Banerjee et al. (1984) reported on the growth kinetics of phenol and related compounds. They found phenol, benzoic acid, and resorcinol supported growth of the microbial culture, but the chloro-derivates of phenol, anisole, and resorcinol were degraded through co-metabolism only. Deeley et al. (1985) found microorganisms in raw sewage that degraded phenol without any lag, while with landfill leachate microorganisms, there was a lag period before significant degradation occurred.

Factors Affecting Biodegradation of Petroleum Hydrocarbons

Chemical and structural factors affecting the biodegradation of the various components of petroleum hydrocarbons were discussed in the preceding pages. However, there are several other factors that can have a significant effect on the biodegradation of these compounds. These factors include photolytic activity, solubility, sorption on solids, presence of surfactants, oxygen, nutrients, temperature, and pH.

Photolytic activity

It is expected that photo-oxidation of the compounds in petroleum hydrocarbons would produce products that are more polar than the parent compounds because of the oxidation. These compounds will be more water-soluble and are likely to be more biodegradable (Foght and Westlake 1984). In oil lenses formed in water after a spill, photo-oxidation may lead to polymerization which may lead to the formation of tarry residues that are difficult to biodegrade (Payne and Phillips 1985). In terrestrial situations, photo-oxidation does not play a major role in the natural degradation processes (Bartha 1986).

Solubility

The solubility of the compounds in petroleum hydrocarbons in water is an important property for evaluating their biodegradation. In general, the higher the aqueous solubility of the compound, the more likely it will biodegrade. A liquid or dissolved aromatic hydrocarbon will be degraded in preference to a solid phase aromatic compound (Foght and Westlake 1984).

Sorption on solids

Hydrophobic compounds having low water solubility tend to concentrate on surfaces. Thus, many compounds present in petroleum hydrocarbons sorb on the particulate matter present (Bartha 1986). The sorption of these compounds on soils may have varying effects depending on the type of sorbent, the nature

of the compound, and its concentration. Subba-Rao and Alexander (1982) found that the degradation of benzylamine sorbed on montmorillonite clay was influenced by the concentration of benzylamine and clay, while the degradation of benzoate was usually not affected by the clays, montmorillonite, and kaolinite. Naphthalene biodegradation under denitrifying conditions in soil-water systems was studied by Mihelcic and Luthy (1988). They found that naphthalene sorption-desorption was reversible and rapid compared to the rate of microbial degradation.

Presence of surfactants

Surfactants can interact with the compounds present in petroleum hydrocarbons and increase their aqueous solubilities (Ellis et al. 1986). Thus, the presence of surfactants, natural or otherwise, may make these compounds available to the microbes for biodegradation. In addition, surfactants can mobilize compounds that are sorbed on the particulate surface, increasing bioavailability of the contaminant.

Some microbes produce biosurfactants to aid in solubilizing compounds that have low solubilities (Lang and Wagner 1987). These biosurfactants are, generally, glycolipids. They can reduce interfacial tension, which produces an emulsion of the compound in water. The finely divided compound in the emulsion results in an increase in the available surface area for contact between cells and the compound, promoting biodegradation (Bury and Miller 1993). Falatko and Novak (1992) reported that biosurfactants produced by gasoline degrading bacteria increased the solubility of the gasoline compounds. The surfactants themselves could adsorb on soil materials which would reduce their ability to solubilize compounds adsorbed on the soils. Oberbremer and Müller-Hurtig (1989) also reported the production of biosurfactants during metabolism of a hydrocarbon mixture containing tetradecane, pentadecane, hexadecane, pristane, trimethylcyclohexane, phenyldecane, and naphthalene by soil microorganisms. The hydrocarbon removal was about 89 percent.

Oxygen

For relatively rapid biodegradation of petroleum hydrocarbons, aerobic conditions are necessary, since anaerobic degradation of these compounds has been demonstrated to be quite slow (Hambrick et al. 1980). The initial attack on many of the molecules present in petroleum hydrocarbons is by oxygen through the oxygenase system, as discussed earlier. In subsequent steps, oxygen is the most common electron sink, but in its absence, nitrate or sulfate may act as an electron acceptor to oxidize the partially oxidized intermediates (Bartha 1986). The recommended level of DO for petroleum hydrocarbon degradation is greater than 2 mg/L in liquid cultures (Stroo 1990).

Nutrients

In water and soil, the growth of petroleum-hydrocarbon-utilizing cells is limited if mineral nutrients, especially N and P, are in short supply (Bartha 1986). Iron was found to be limiting in clean, offshore seawater, but should not be a limiting factor in most cases (Dibble and Bartha 1976). In order to prevent nutrient limitations in biological treatment processes, the ratio of C:N:P is kept at 120:10:1 based on the organic carbon content of the feed (Sims et al. 1989). In actual practice, during the course of biodegradation, nutrient levels are monitored and kept above a set target level (e.g., 5 mg/L N and 1 mg/L P).

Temperature

Temperature has a profound effect not only on the physical status of the hydrocarbons present, but also on rates of microbial metabolism. In colder conditions, liquid hydrocarbons become waxy solids; soluble hydrocarbons precipitate, and their solubility decreases considerably. This altered physical status affects their bioavailability. Lowering of the temperature slows biodegradation rates significantly. The Q_{10} (temperature quotient) values for petroleum hydrocarbon biodegradation in soil and in seawater vary from 1.7 to 2.7 (Bartha 1986).

pH

The optimum pH range for the degradation of petroleum hydrocarbons is from 7 to 8.5 in natural waters. Hambrick et al. (1980) found that biodegradation of oil increased with increasing pH (up to pH 8.0). In acidic soils liming to pH 7.8 to 8.0 has been reported to be stimulatory for the biodegradation of petroleum hydrocarbons (Bartha 1986).

Bioslurry Process

The bioslurry process has been used to remediate contaminated soils from various sources (USEPA 1990).

Ross (1991) presented two case studies where slurry-phase bioreactors were used to remediate contaminated soils. In the first case, pentachlorophenol- (PCP-) contaminated soil was tested for biodegradation in a slurry reactor using a PCP-degrading microbial consortia. PCP was found to degrade well under the conditions of the test. Later, it was found that it was advantageous to wash PCP off the soil particles greater than 60 mesh size and treat the soil washings in a bioreactor. In the second case study, a slurry-phase bioreactor was used to treat oil refinery waste sludge. The oil and grease in the sludge could be biodegraded at a relatively rapid rate compared to land treatment.

Removal of PAH compounds in the system ranged from 76 to 92 percent. Stroo et al. (1988) reported a field study where 750 cu yd of soil contaminated with about 400 mg/kg of the pesticides 2,4-D and 4-chloro-2-methylphenoxy acetic acid (MCPA) were bioremediated in a 26,000-gal reactor. In 13 days, the levels of the pesticides were reduced to less than 20 mg/kg of soil, with an estimated half life of 21 days. Brox and Hanify (1989) described the use of EIMCO Biolift reactors for treating contaminated soils in a slurry form. They presented data on the treatment of an oil refinery sludge with an oil and grease content of about 40 percent by weight in the batch bioreactor. The total solids concentration in the reactor was 25 percent by weight. In 39 days, the reduction in oil and grease content was about 60 percent. Gas emission control was necessary during the treatment.

Castaldi and Ford (1992) used 20-L batch slurry reactors to evaluate the bioremediation of tarry sludge from petrochemical production. The sludge contained about 25 percent by weight oil, significant levels of volatile compounds (such as benzene, toluene, and styrene) and lesser amounts of semi-volatiles (such as anthracene, chrysene, and naphthalene). The reactors were seeded with acclimated cultures from the petrochemical wastewater treatment plant, aerated, and mixed, and sufficient nutrients were added to promote microbial growth. The results indicated that the volatile components in the mixed liquor were depleted within the first 15 days of testing. The semi-volatile compounds were below detectable levels between 15 and 30 days after the start. An examination of the waste residue after 90 days of aeration revealed a 20 percent reduction in oil and grease content, and the concentration of volatiles and semivolatiles was below detection limits. The data on air emissions from the reactors indicated that the volatile organics were at low levels in the head space after the first week of the treatment process.

3 Bench- and Pilot-Scale Evaluations

Two bench- and pilot-scale evaluations of the bioslurry process for remediation of petroleum hydrocarbon contaminated soils have been completed at the U.S. Army Engineer Waterways Experiment Station (WES), Vicksburg, MS. The first treated contaminated soils from the Ninth Avenue Dump Superfund Site in Gary, IN, and the second involved soils from Fort Sheridan, IL. In this section the data generated from these two studies will be presented.

Ninth Avenue Dump Superfund Site, Bench-Scale Evaluation

Bench-scale bioslurry treatment evaluations were conducted at WES. The objective of the bench-scale evaluation was to collect data needed to optimize the operating conditions of the subsequent pilot-scale bioslurry tests.

The contaminated soil for testing was obtained from the Ninth Avenue Dump Superfund Site in Gary, IN. A remedial investigation/feasibility study (RI/FS), performed by a consultant earlier, had revealed that the soil at the site contained PAHs, ketones, chlorinated ethanes, BTEX, plasticizers, dioxin/furans, and heavy metals (USEPA 1991).

Material and methods

Bioslurry reactors. The batch reactors were all glass with a 5-L capacity. An exterior laboratory mixer with digital readout (for the amount of mixing energy being spent) was used for keeping the solids in suspension. Aeration was provided by diffused air supplied through vents located in the mixer shaft. The mixing rate was set at 300 rpm, and the temperature was maintained at 25 °C.

Contaminated soil was screened through a No. 10 sieve (nominal opening 2 mm) to remove larger particles and stones. The sieved soil was mixed with distilled water to obtain a 30 percent slurry by weight. Five different

treatment conditions were evaluated in duplicate in the bioslurry reactors. Treatment conditions are shown in Table 1. Reactors 1 and 2 had sufficient nutrients (N and P) but no external microbial inoculum or surfactant with the slurried soil. Reactors 3 and 4 had nutrients and a mixture of two surfactants, Ten T-Maz-80K and S-Pan-Sorbitan, manufactured by PPG-Maiser, Inc., Pittsburgh, PA, but no external microbial inoculum. The surfactant dosage was about 125 mg/L (80 percent Maz-80K and 20 percent Sorbitan). Reactors 5 and 6 had nutrients, selected microbial inoculum developed by Sybron Chemical Co., Inc., Birmingham, NJ, that was capable of degrading petroleum hydrocarbon, and the surfactant mixture. Reactors 7 and 8 had nutrients and the special microbial inoculum, but surfactants were not added. The last set of reactors, reactors 9 and 10, were the abiotic controls, with nutrients and 5,000 mg/L of mercuric chloride to stop microbial activity, and no microbial inoculum or surfactants were added.

Table 1
Operating Conditions for Bench-Scale Bioslurry Reactors, Ninth Avenue Dump Superfund Site

Reactor No.	Microbial Inoculum	Surfactants ¹	Poison	Comments
1	None	None	None	Native microbes
2	None	None	None	Native microbes
3	None	Present	None	Native microbes
4	None	Present	None	Native microbes
5	Present (Sybron)	Present	None	--
6	Present (Sybron)	Present	None	--
7	Present (Sybron)	None	None	--
8	Present (Sybron)	None	None	--
9	None	None	Mercuric chloride	--
10	None	None	Mercuric chloride	--

¹ Surfactants were a mixture of Ten T-Maz-80K (80 percent) and S-Pan-Sorbitan (20 percent).

Sampling and analyses. A grab sample of the untreated soil slurry was collected prior to its placement in the bioslurry reactor to characterize it physically and chemically.

Samples of treated soil slurry from the bioslurry reactors were also collected periodically using the sampling valve at the bottom.

The untreated and treated soil slurry samples were analyzed for total petroleum hydrocarbons (TPHs), BTEX, PAHs, total solids, volatile solids, DO,

oxygen uptake rate (OUR), pH, ammonia, total- and ortho-phosphate, temperature, and microbial counts.

The analyses were performed by either USEPA-approved methods (USEPA 1983, 1986) or Standard Methods (American Public Health Association (APHA) 1989). Ammonia nitrogen was measured by using an ion probe (Orion 95-12 Probe/901 Ion Analyzer), and the phosphate determinations were made by Hach Kit PO-24.

Microorganisms capable of degrading various organic compounds in petroleum hydrocarbons were evaluated in the bioslurry reactors periodically. A basal salt media amended with the specific organic substrate was used to enumerate these microorganisms in the reactors. Specific organic compounds evaluated were semivolatiles (fluorene, pyrene, phenanthrene, 2-methylnaphthalene), and volatiles (toluene, ethylbenzene, xylene).

The head space off-gases in the reactors were analyzed for volatile organic compounds using a photoionization detector (PID) (HNU Model III) (HNU Systems, Inc. (HNU) 1992). In the laboratory bioslurry reactors, the gases leaving the reactors were not recirculated. As a result, volatile compounds present in the soil during mixing and aeration volatilized and escaped the reactors.

Results

The target compounds for the evaluation of the performance of the bioslurry reactors were the TPHs. The removal behavior of BTEX and PAHs in the reactors provided additional evidence of their performance for the removal of petroleum hydrocarbon components. Figure 2 shows TPH removals in the bioslurry reactors. Results show that there was fairly rapid removal of TPH compounds in all reactors in the first few days and then removal rates leveled off. The high removals in reactors 9 and 10, the abiotic controls, indicated that abiotic processes such as volatilization and hydrolysis were playing a significant part in the removal process. It should be recognized that a TPH test measures the aliphatic components in the petroleum hydrocarbon, so it by no means totally represents all the diverse components present.

The high initial volatilization of petroleum hydrocarbons in the soil was confirmed by the photoionization detector (PID) data presented in Figure 3. The abiotic control reactors had much higher PID values compared to other reactors which might indicate that biotic processes reduced the level of the compounds in the reactor. PID readings mostly measure the volatile aromatic organic compounds. Therefore, they do not parallel the TPH data presented. An estimate of the amount of volatile compound removals from the reactor based on gas flow and PID measurements of the exit gases throughout the course of the study indicated that a total of 560 mg of organic compounds was volatilized from the abiotic controls. Similar calculations on the biotic



Figure 2. Bench-scale bioslurry reactor—TPH removals in different reactors, Ninth Avenue Dump Superfund Site

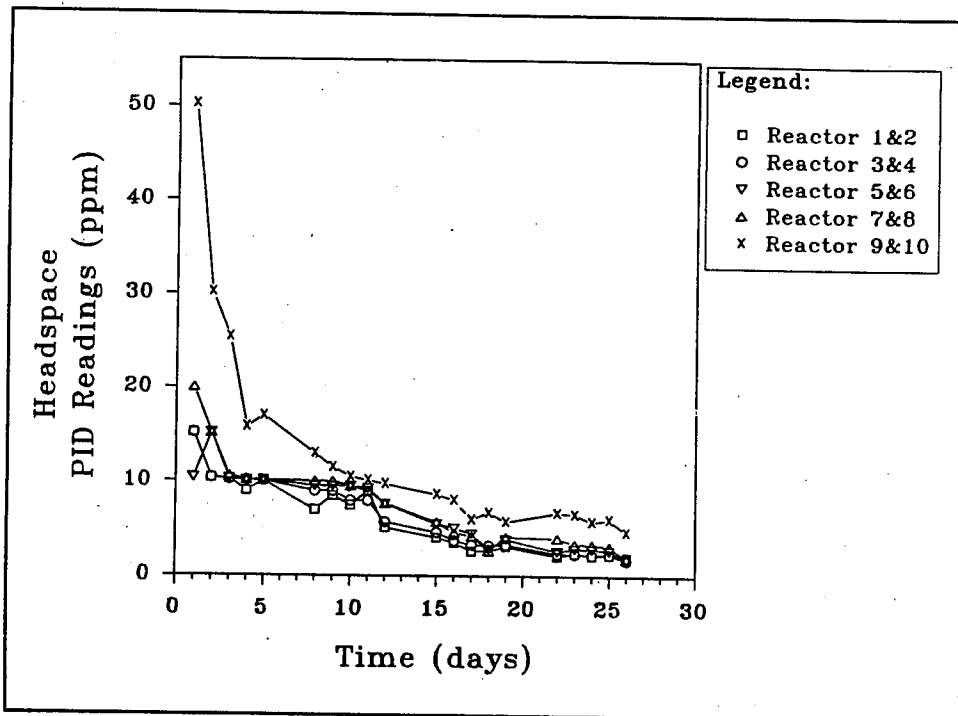

Figure 3. Bench-scale bioslurry reactor—PID data, Ninth Avenue Dump Superfund Site

systems showed only a 277-mg loss of organic compounds by volatilization, which was about 49 percent of that volatilized in the abiotic system. Thus, in the biotic reactors the removal of organic matter not volatilized must have been by biodegradation. As indicated earlier, PID does not measure all the volatile organic compounds in the gaseous phase but only some of the aromatic compounds. Therefore, the PID data presented give a lower than actual concentration of the volatile organic compounds exiting the reactors. The data on BTEX removals are presented in Figure 4. It can be seen that BTEX removal trends followed the PID data, which confirmed that the volatile aromatics are removed in the gaseous phase, initially. The lower values of BTEX in the biotic reactors compared to the abiotic ones also indicated that possibly there was biological degradation of the BTEX compounds. The reactors containing surfactants removed the BTEX compounds better than the ones that had no surfactants. However, over the 30-day test period, the differences were only minor. The presence of the selected microbial inocula in the reactors also gave marginally better BTEX removals compared to the native biota.

Removal of total PAHs in the reactors is shown in Figure 5. It appears that the initial sample PAH value was in error because it was lower than the data presented for individual PAH compounds and also lower than values obtained in some reactors after 30 days of biodegradation. If the time zero data for total PAHs are discounted, the data presented in Figure 5 show very good PAH removal by the bioslurry reactor in 30 days contact time. Since most PAHs are not volatile, the PAH removal in these reactors must have been due

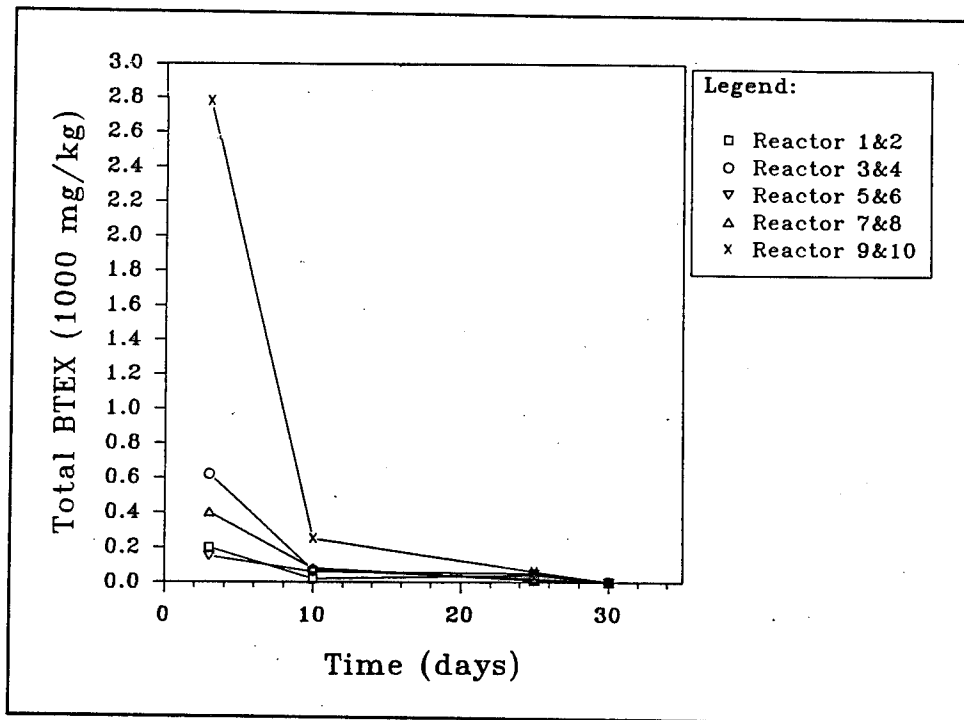

Figure 4. Bench-scale bioslurry reactor—total BTEX removals, Ninth Avenue Dump Superfund Site

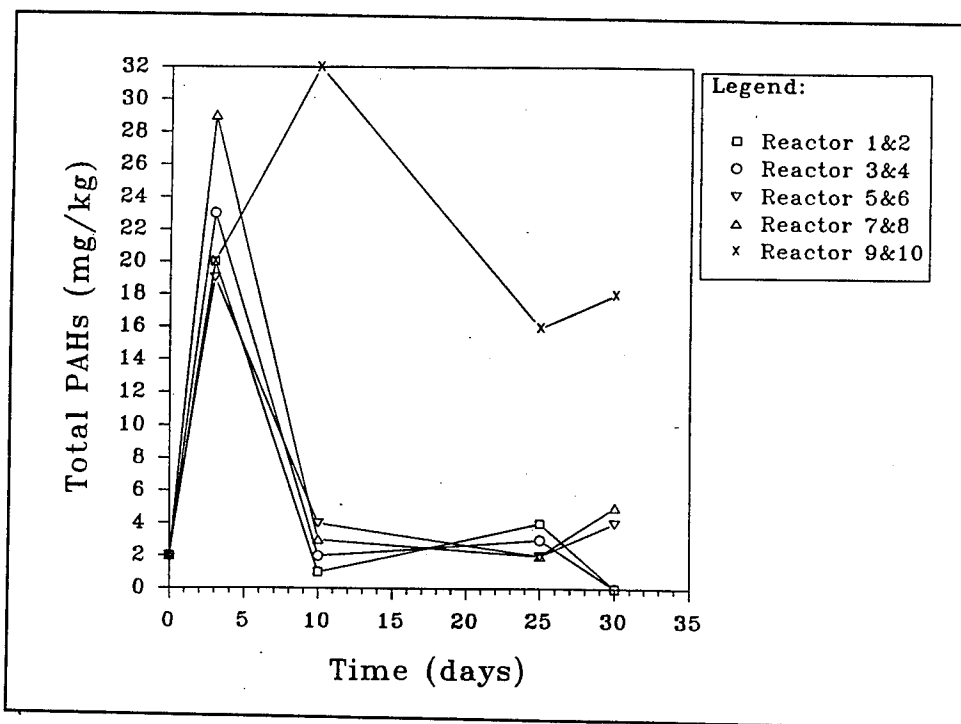

Figure 5. Bench-scale bioslurry reactor—total PAH removals, Ninth Avenue Dump Superfund Site

to biodegradation. The abiotic controls showed minor amounts of PAH removal. The differences between the PAH removal of reactors with surfactants and selected microbial inoculum, and reactors without these amendments was not significant, i.e., the reactors with native biota in the soil without any surfactants performed equally well compared to the reactors with the surfactants and selected microbial inoculum.

The oxygen uptake rates (OURs) for the reactors are shown in Figure 6. The OURs in the biotic reactors were much higher compared to the abiotic control reactors indicating that aerobic biodegradation was occurring. The increase and decrease of the OURs in some of the biotic reactors were related to the ammonia concentration in the reactors (Figure 7). When ammonia levels in the reactors fell below 5.0 mg/L, additional ammonium phosphate was added to maintain the ammonia concentration above 5.0 mg/L. The lowering of ammonia concentration below 5.0 mg/L reduced the biological activity of the reactor, as evident by the lowered OUR readings. When the ammonia concentrations were enhanced, the biological activity also increased.

The growth of microorganisms in the bioslurry reactors was evaluated in terms of utilizing specific organic compounds present in petroleum hydrocarbons (as mentioned in the Material and Methods section). Samples from the abiotic reactors (poisoned with mercuric chloride) exhibited very little growth during the enumeration evaluations. The lack of viable microbial counts utilizing the compounds present in petroleum hydrocarbons in the abiotic

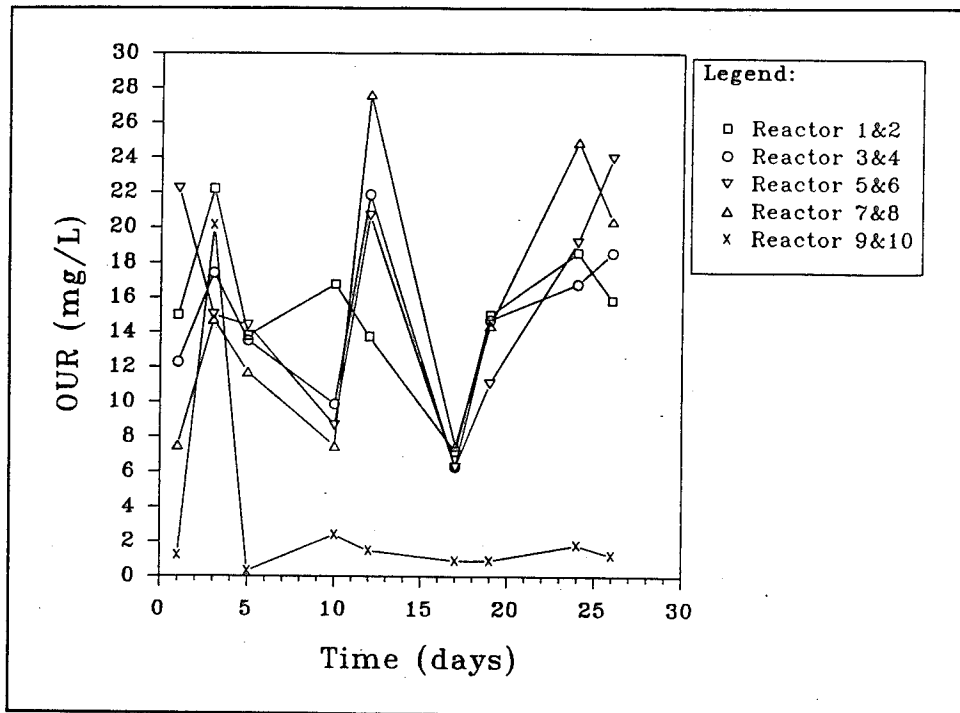

Figure 6. Bench-scale bioslurry reactor—OUR data, Ninth Avenue Dump Superfund Site

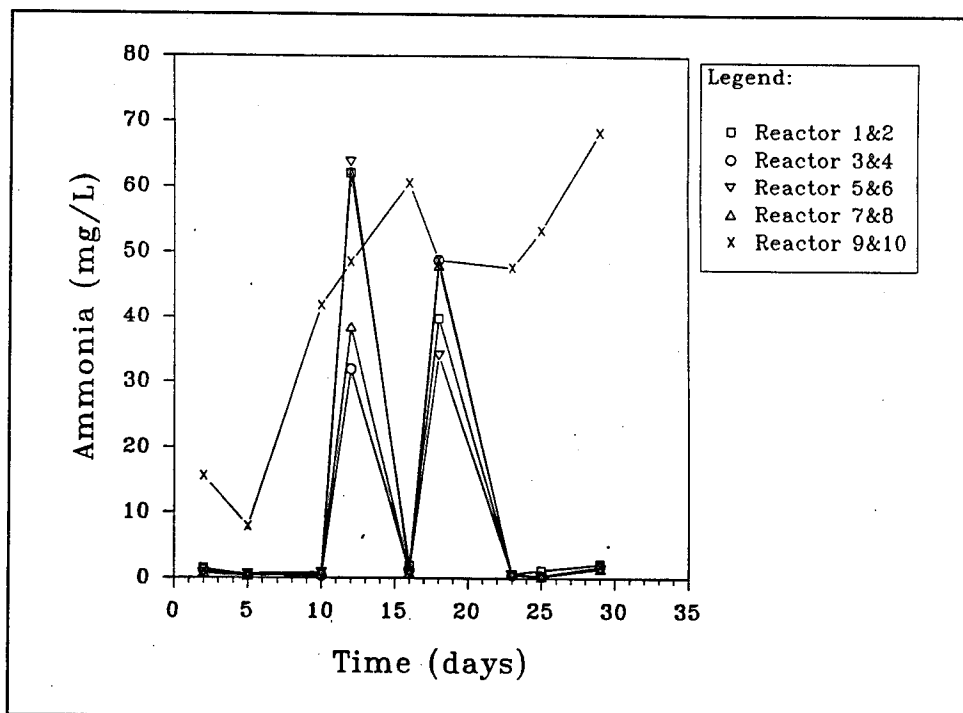

Figure 7. Bench-scale bioslurry reactor—ammonia data, Ninth Avenue Dump Superfund Site

controls further supported the contention that the loss of TPH observed in thereactors was solely due to abiotic processes.

The growth of microorganisms capable of utilizing specific compounds was evaluated using the basal medium. Generally, there was good initial growth of the organisms using the PAH compounds with or without the surfactants and the selected microbial inocula. Figure 8 shows the microbial growth on fluorene, measured as colony-forming units (CFUs). Growth on the BTEX compounds was comparatively less as can be seen in Figure 9 where ethylbenzene was added to the basal media.

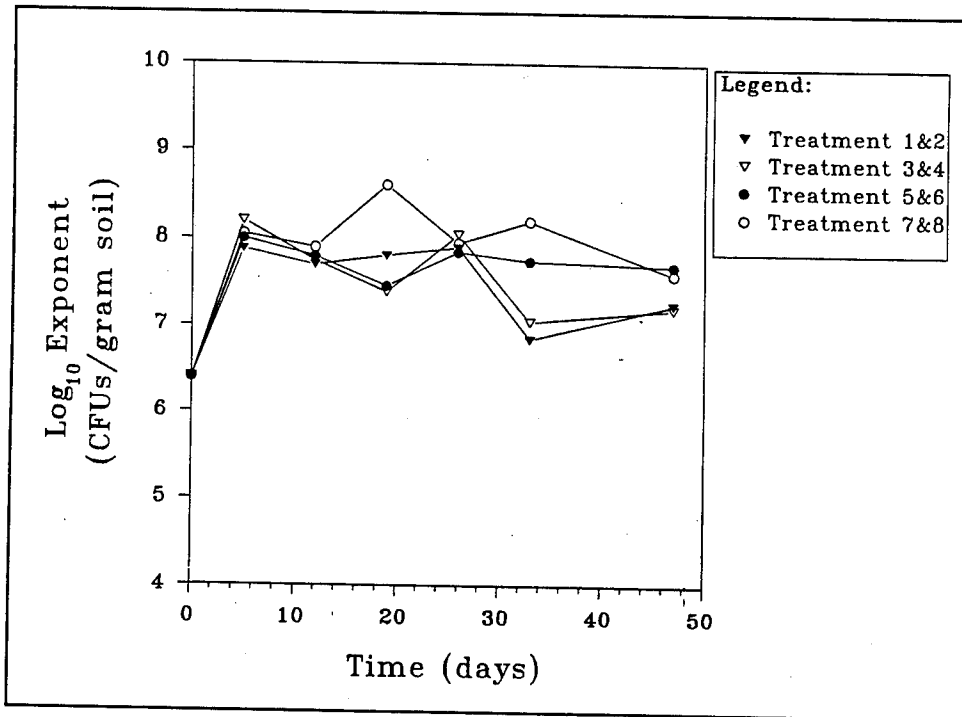

Figure 8. Bench-scale bioslurry reactor—microorganisms recovered on basal salts agar with fluorene, Ninth Avenue Dump Superfund Site

The following conclusions can be made from the results of the bench-scale studies:

- a. The high removal of TPH from the reactors was to a great extent caused by abiotic processes (i.e., volatilization), although there was strong evidence that biodegradation of some of the nonvolatile components was also occurring.
- b. The high removal of BTEX compounds in the reactor was also due to abiotic process (i.e., volatilization), but the presence of microorganisms capable of growing on the BTEX compounds indicates that there may have been some biodegradation of these compounds during the test period.

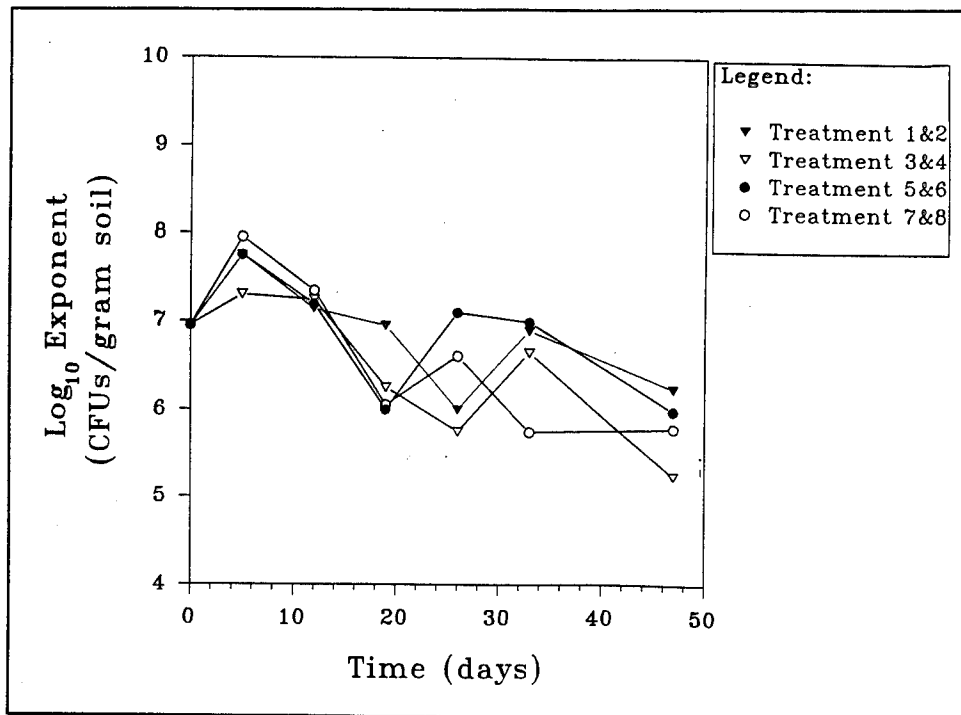

Figure 9. Bench-scale bioslurry reactor—microorganisms recovered on basal salts agar with ethylbenzene, Ninth Avenue Dump Superfund Site

- c. The high removal of PAH compounds was probably due to biodegradation, although lower molecular weight PAH compounds, such as naphthalene, could have been removed by volatilization. The presence of microorganisms in the reactor capable of growing on selected PAH compounds does suggest that biodegradation of these compounds was going on to some extent.
- d. The data on the ammonia concentrations and the OURs of the mixed liquor in the biotic reactors also confirmed high microbiological activity in the reactors giving further evidence of the possibility of biodegradation of the TPH compounds present in the soil slurry.
- e. The addition of surfactants did not produce significant evidence of improved removal of TPH compounds compared to systems without the surfactants.
- f. The addition of selected microbial inoculum to the reactors also did not produce more biodegradation of the TPH compounds compared to the reactors with native microorganisms.

Ninth Avenue Dump Superfund Site, Pilot-Scale Evaluation

Based on the bench-scale results, pilot-scale evaluations were conducted using the contaminated soils from the Ninth Avenue Dump Superfund Site in Gary, IN (Versar, Inc. 1992).

The objectives of the pilot-scale tests were to collect data and demonstrate the feasibility of the bioslurry process to treat contaminated soil and debris. From the bench-scale experience, it was decided to install gas recirculation systems in order to provide sufficient contact time in the reactor for the volatile components in the soils to be biodegraded.

Material and methods

Soils. The soils for the pilot-scale tests were collected near test pit TP-29B at the Ninth Avenue Dump Superfund Site. These soils, collected from a depth of about 6 ft, were passed through a 1-5/8-in. screen to exclude larger debris, into 55-gal steel drums for transportation to WES. The contaminated soil placed in the drums contained approximately 10 to 20 percent wood sticks and splinters ranging from 1 to 3 in. in length and from 1/16 to 1/2 in. in diameter.

Before testing, the soils from different drums were composited to obtain a uniform quality in each test reactor. The composited soil was then passed through a No. 4 sieve (nominal opening 4.75 mm) to remove any remaining debris.

EIMCO reactors. Bioslurry treatment evaluations were conducted using reactors manufactured by EIMCO, Inc., Salt Lake City, UT. These stainless steel reactors have a 60-L capacity, with central raking, air lift, air diffusion, and mixing devices built-in. Figure 10 shows a schematic of the reactor. Air is supplied to the reactor by an external compressor via two horizontal fine bubble elastomeric membrane diffusers mounted on the rake arms, which rotate through the slurry solution. Particles are kept in suspension by the diffused aeration and the downward axial flow impeller mixing device attached to the vertical shaft. Any settled particles are raked to a central point from where the airlift pump redistributes them to the top of the reactor.

Six replicate reactors were set up with the composited soil to give a 30 percent soil-water slurry. Sufficient nutrients (N and P) were added to more than satisfy the demands of the microbes degrading the petroleum hydrocarbon contaminants. The temperature was controlled at 25 °C, and sufficient aeration was provided to maintain DO levels of at least 2.0 mg/L. The test was continued for 57 days (September 4, 1991, to October 30, 1991).

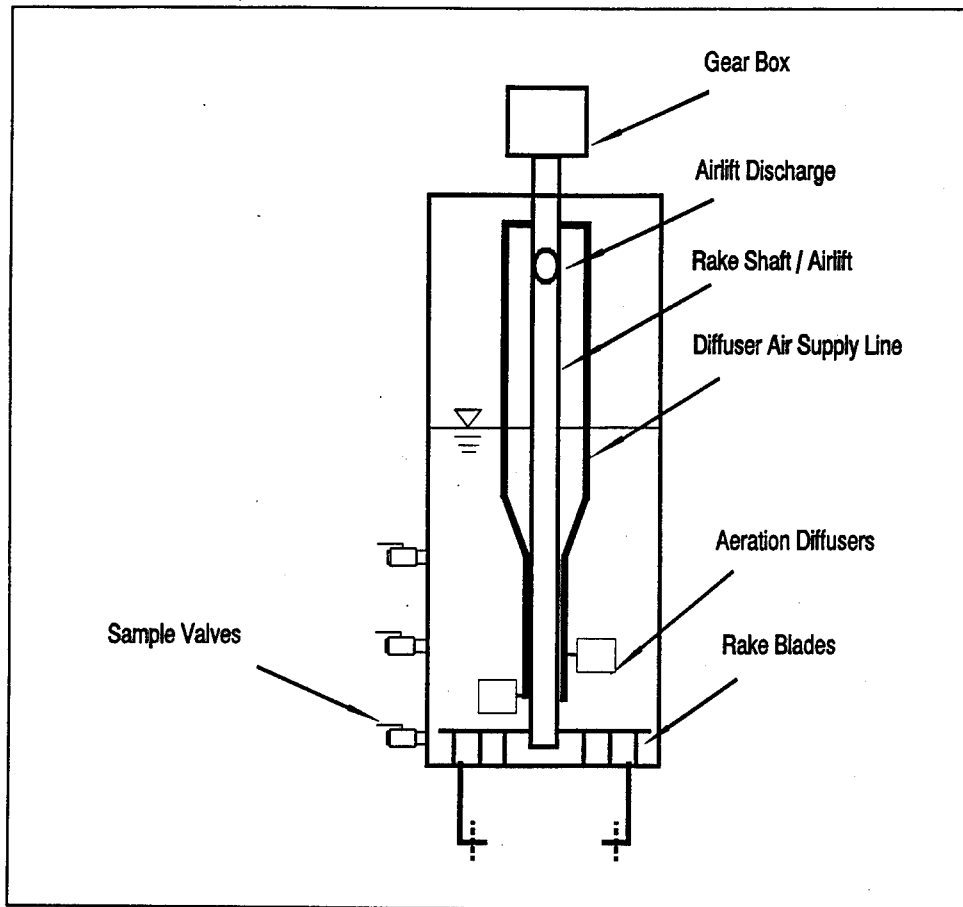

Figure 10. Bioslurry reactor used for pilot-scale tests

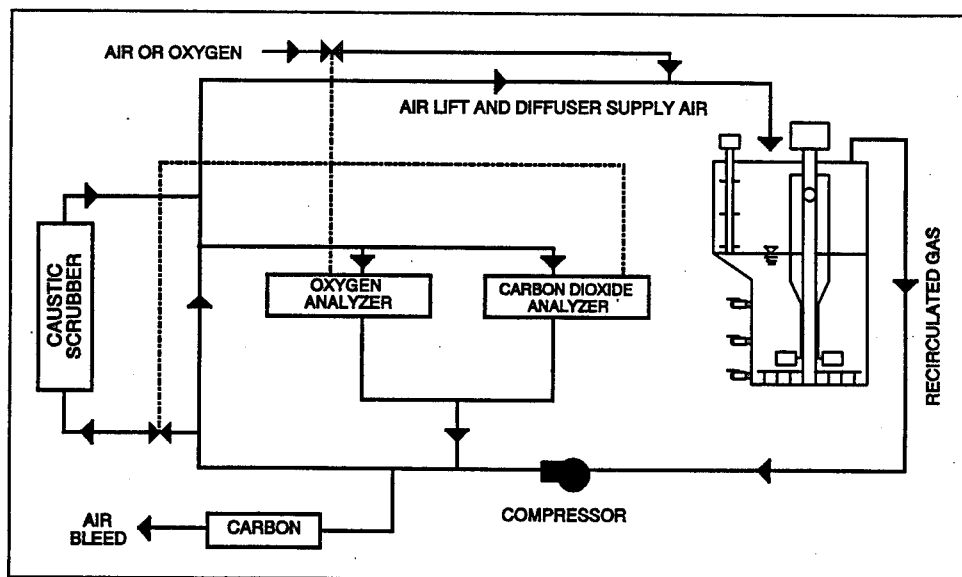

Figure 11. Bioslurry reactor gas recirculation system

The exit gases from the slurry reactor were recirculated to give a closed-loop treatment process. Figure 11 shows the gas recirculation system for the EIMCO reactors. The CO₂ gas produced during the biodegradation could be absorbed by a caustic scrubber process, and fresh air could be allowed to enter the system based on the level of CO₂ and O₂ in the exit gas stream.

Sampling and analyses. Initial untreated soil samples were collected to characterize the contaminated soil after compositing but before water addition. During the progress of the bioslurry test, periodic soil slurry samples were taken from the six reactors through the sampling ports. After the test ended, samples of treated soil slurry were also taken for analyses.

The soil slurry samples were centrifuged to separate the soil solids from the liquid phase. Both the soil and aqueous phases were analyzed for different petroleum hydrocarbon compounds. The main purpose of the research was to evaluate reduction of petroleum hydrocarbon residues from the soil phase by bioremediation; therefore, more emphasis was placed on the soil phase analyses.

The analyses of various parameters such as BTEX, PAHs, TPH, OUR, total solids, and volatile solids were performed by either USEPA-approved methods (USEPA 1983, 1986) or Standard Methods (APHA 1989). Ammonia nitrogen was measured by using an ion probe (Orion 95-12 Probe/ 901 Ion Analyzer). The phosphate determinations were made by Hach Kit PO-24. Enumeration of microbes present in the reactors capable of utilizing various compounds present in petroleum hydrocarbons was done by the use of a basal salt media amended with specific compounds as was done for the bench-scale studies.

Results

TPH removals. The main thrust of the study was to evaluate the removal of TPH compounds from the contaminated soils. The TPH data are presented in Table 2. It can be seen that in 48 days about 91 percent of the TPHs were removed from the reactors. The TPH data in Table 2 are in terms of soil wet-weight basis. The untreated soil had an average TPH concentration of about 27,170 mg/kg. If the TPH removal was about 91 percent, then the residual TPH after treatment would be about 2,445 mg/kg. This value would be greater than the allowable level under the USEPA leaking underground storage tank clean-up guidelines, which varies from 50 to 500 mg/kg, depending on such site-specific factors as depth to groundwater, presence of sand, and water wells nearby.¹ Thus, the soil may need further bioremediation in the form of land treatment to bring the level of TPHs under the allowable limits.

BTEX removals. As indicated before, reactor off-gases were recirculated, with the result that any biodegradable volatile compounds, such as BTEX

¹ Personal Communication, June 1993, Bill Peterson, Region VII, USEPA, Kansas City, KS.

Table 2
Pilot-Scale Bioslurry Reactors—TPH Concentrations (mg/L),¹
Ninth Avenue Dump Superfund Site

Day	Reactor Number					
	1	2	3	4	5	6
1	1,280	--	1,280	--	--	--
7	--	--	--	927	--	994
13	--	--	--	--	1,320	1,150
20	--	--	771	--	--	762
27	--	339	--	--	--	314
34	121	--	--	--	--	877
41	--	--	--	129	--	175
48	--	--	--	--	--	105

Note: -- = Not analyzed.
¹ Results for the TPH samples reported on wet-weight basis.

compounds, would have ample opportunity to be metabolized by the microbes present. The initial benzene data from all reactors indicated that the level was below detection level and periodic sampling of the reactor contents did not indicate the presence of benzene at any time.

In the case of toluene, there was some discrepancy in the early concentrations of the compound in the reactors. For example, the concentrations of toluene were found to be below detection level of 10 ppb on day 1, but on day 7 the levels varied from 210 to 7,600 ppb. However, after day 7 the concentration dropped to below detection level of 5 ppb in all the reactors, indicating a good removal.

The initial data for ethylbenzene in the reactors were very similar to that of toluene, i.e., day 1 had very low (below detection level) concentrations while day 7 had relatively high concentrations (340 to 780 ppb) of the compound. Again, after day 7, the concentrations in the reactors were quite low and below detection level of 5 ppb.

The same trend was also observed with xylene. The day 1 xylene values varied from 13 to 42 ppb; the day 7 concentrations were quite large (9,500 to 12,000 ppb), but the concentrations of xylene in subsequent days were less than the detection limit of 5 ppb in all reactors.

It is unclear why the day 7 samples had higher values of toluene, ethylbenzene, and xylene than day 1, but sampling errors caused by incomplete

mixing could account for such a variation. However, BTEX removal in the bioslurry reactors was observed.

The soil slurry aqueous BTEX concentrations were evaluated at the end of the experiment. The reported values of toluene in aqueous phase in all but one reactor were below the detectable limit of 10 ppb. The level in one of the reactors (reactor 3) was 6 ppb, which is still below the detection limit. This level is still much lower than the 150 ppb offsite aquifer clean-up guide established by USEPA.¹

PAH removals. PAH removals in the bioslurry reactors after 48 days are summarized in Table 3. Concentrations of PAHs in the bioslurry reactors were below detection limits. The percent removals, shown in the Table 3 for PAH compounds having average concentrations below the detection limit at day 48, were calculated assuming these concentrations were half the value of the detection limit i.e., $495 \text{ ppb}/2 = 247.5 \text{ ppb}$. PAH percent removals varied from 63.0 percent for benzo(a)pyrene to 97.8 percent for phenanthrene. Even four- to five-ring PAHs were degraded to a substantial extent. Marks et al. (1992) had reported greater than 90 percent removals of benzo(a)pyrene and other PAH compounds in laboratory continuous-stirred tank reactors using petrochemical sludges. Using a bioslurry reactor for remediating petroleum sludges, Castaldi and Ford (1992) reported that the semivolatile PAH compounds were below the detection limits between 15 and 30 days after the start.

The soil slurry aqueous PAH concentrations were evaluated at the end of the experiment. Table 4 shows the average soil slurry aqueous PAH concentrations. Some of these values are relatively high and will require further treatment before disposal.

DO levels in the reactors remained above 5.0 mg/L throughout the study. OURs were high initially (30 to 40 mg/L/hr) indicating high bioactivity, but with time they fell to progressively lower values (3 to 7 mg/L/hr) when the substrate level in the reactor decreased, resulting in reduced bioactivity. Ammonia levels varied considerably because additional amounts were added on an "as needed" basis to keep the ammonia concentrations high. There was a significant increase in ammonia concentrations (>120 mg/L) in all reactors after day 27 until the end of the experiment. This did not affect the performance of the reactors. Total solids data indicate that the bioslurry reactors did not have 30 percent solids as desired, but were in the range of 10 to 12 percent solids. There was some increase with time in the total solids data in the reactors, which was not matched by an increase in the present volatile solids data. The inconsistencies in the total and volatile solids data could be due to incomplete mixing in the reactors resulting in sampling errors.

The pH values for the different reactors were quite low initially (i.e., day 8 pH values ranged from 4.6 to 5.67), but with time they increased to above

¹ Personal Communication, June 1993, Bill Peterson, USEPA, Region VII, Kansas City, KS.

Table 3
Pilot-Scale Bioslurry Reactors—PAH Removals (soil phase),
Ninth Avenue Dump Superfund Site

Compound	Average Day 1 Concentration, ppb	Average Day 48 Concentration, ppb	Percent Removal ¹
Acenaphthene	2,550	ND (495) ²	90.3
Acenaphthylene	1,054	ND (495)	76.5
Anthracene	768	ND (495)	67.8
Benzo(a)anthracene	1,575	ND (495)	84.3
Benzo(a)pyrene	670	ND (495)	63.0
Benzo(a)fluoranthene	800	260 (495)	67.5
Benzo(g,h,i)perylene	ND (990)	ND (495)	--
Benzo(k)fluoranthene	800	255 (495)	68.1
Chrysene	1,795	306 (495)	82.9
Dibenzo(a,h)anthracene	ND	ND (495)	--
Fluoranthene	3,330	ND (495)	92.6
Fluorene	4,220	ND (495)	94.2
Indeno(1,2,3-c,d)pyrene	ND (990)	ND (495)	--
2-Methylnaphthalene	10,980	ND (495)	97.7
Naphthalene	1,367	ND (495)	81.9
Phenanthrene	11,030	ND (495)	97.8
Pyrene	3,360	481	85.6

¹ Percent removals for compounds with ND at day 48 were based on half the detection limit concentrations, i.e., $495/2 = 247.5$ ppb.

² ND = Not detected at the detection limit shown.

Table 4
Pilot-Scale Bioslurry Reactor Study—Average Concentrations of
Aqueous Phase PAH Compounds in Treated Soil Slurry, Ninth
Avenue Dump Superfund Site

Compound	Average Concentration, µg/L, After Treatment	Comments
Benzo(a)pyrene	167	Average of 6 reactors
Total benzofluoranthene	168	Average of 6 reactors
Benzo(g,h,i)perylene	47	Average of 6 reactors
Chrysene	64	Average of 6 reactors
Indeno(1,2,3-c,d)pyrene	68	Average of 6 reactors
Pyrene	49	Average of 6 reactors

neutral values (7.7 to 8.9). The toxic consequences of low initial pH values were not evident in bioactivity data as measured by DO uptake rates. Gross microbial counts of the samples from the reactors using basal salt agar with peptone, tryptone, yeast extract, and glucose (PTYG) also indicated good growth from 4×10^5 colony forming units/gram (CFU/g) of soil in week 1 to 1×10^{10} CFU/g of soil in week 2. The number of microorganisms degrading specific compounds, like phenanthrene and xylene, also increased by several orders of magnitude after the first week.

The following conclusions can be made from the results of the pilot-scale studies:

- a. The bioslurry reactor with vapor recirculation removed greater than 90 percent of the TPHs in the soil in 48 days, but for some contaminated soils this may not be sufficient and further bioremediation may be necessary.
- b. BTEX removals in the bioslurry reactors were very good despite some discrepancies in BTEX concentrations on day 7. The vapor recirculation system allowed for a longer contact time with microbial biomass in the reactors which aided the biodegradation of these compounds. The aqueous phase BTEX levels were below the detection level of 10 µg/L in all reactors which would not be a disposal problem.
- c. PAH removals were also quite substantial. In most cases, concentrations in the soil phases after the treatment were below detection levels. The calculated percent removals for some recalcitrant PAHs such as benzofluoranthene, chrysene, and pyrene in the bioslurry reactors ranged from 67.5 to 85.6 percent. Aqueous phase PAHs were somewhat high (varying from 47 to 180 µg/L), and further treatment would be necessary.
- d. Other parameters measured such as OUR and microbial enumeration indicated there was substantial bioactivity in the reactors.

Fort Sheridan Site, Bench-Scale Evaluation

A bench-scale bioslurry study was conducted to evaluate the feasibility of treating soils contaminated with petroleum hydrocarbons from Fort Sheridan, IL. These soils were contaminated with gasoline and had much lower TPH levels compared to the Ninth Avenue Dump Superfund Site. The objective of the bench-scale study was to obtain sufficient data to optimize the operation of the planned pilot-scale bioslurry experiments.

Material and methods

Bioslurry reactors. The batch reactors were the same as those used for the soil bioremediation bench-scale studies for the Ninth Avenue Dump Superfund Site described earlier. These reactors had no vapor recirculation feature, so the volatilized compounds escaped with the exit gases.

The soil and slurry preparation procedures were also the same as described earlier for the Ninth Avenue Dump Superfund Site study. Table 5 shows the treatment conditions studied.

Reactor Nos.	Treatment Conditions
1 and 2	Native microbes + nutrients
3 and 4	Native microbes + nutrients + surfactants (1.5%)
5 and 6	Native microbes + nutrients + surfactants (3%)
7 and 8	Poisoned control (5,000 mg/L HgCl ₂)

The surfactant used in this study was T-Maz-80K, manufactured by PPG-Maiser, Inc., Pittsburgh, PA. The surfactant dosage was based on the dry weight of the soil.

Nutrient ammonia concentrations were maintained at 40 mg/L in the reactors by adding ammonium chloride on an "as needed" basis, i.e., when the ammonia concentrations fell below 40 mg/L. Similarly, the total phosphate concentrations in the reactors were controlled at 5 mg/L by adding sodium phosphate.

Sampling and analyses. Samples of soil slurry from the reactors were collected before, during, and at the end of the test. Slurry samples were centrifuged, and soil samples were analyzed for TPHs, PAHs, volatile organics, total solids, and total volatile solids. The slurry samples were also used to measure pH, ammonia, DO, OURs, and phosphate concentrations.

In addition, the microbial enumeration of the slurry liquid was made using basal salts nutrient medium and basal salts medium containing various hydrocarbons. The specific hydrocarbons used were toluene, benzene, ethylbenzene, naphthalene, and phenanthrene.

Analyses were performed by either USEPA-approved methods (USEPA 1983, 1986), or Standard Methods (APHA 1989). Ammonia was measured using an ion probe (Orion 95-12 Probe/901 Ion Analyzer) and phosphate determinations were made by a Hach Kit PO-24.

The headspace off-gases in the reactors were analyzed for volatile organic compounds using a photoionization detector (HNU Model III) (HNU Systems, Inc. 1992).

Results

TPH removals. TPH data are presented in Table 6. It can be seen that except for reactors 5 and 6, there was significant removal of TPH in the bioslurry reactors within 16 days. In reactors 1 and 2, most of the TPH was removed as early as day 2, while in reactors 3 and 4 there was substantial removal, but some samples showed small residual amounts. The poisoned reactors (reactors 7 and 8) also removed substantial amounts of TPH which would indicate an abiotic process, such as volatilization, to be the main mechanism responsible for these removals. The presence of high amounts of surfactants (3 percent) in reactors 5 and 6 somehow retarded the volatilization of the components present to give relatively high residual values. Incomplete mixing may have also caused specific samples to have high TPH values.

Average	Day 0	Day 16	Percent Removal
Reactors 1 and 2	203	ND	—
Reactors 3 and 4	203	13	93.6
Reactors 5 and 6	203	170 ¹	16.2
Reactors 7 and 8	203	24	88.2

Note: ND = Not detected.
¹ Reactor 6 TPH value of 600 mg/kg at day 16 was not included.

The data collected by the PID provided evidence of volatilization of some of the hydrocarbons present in the reactors in the first few days (Table 7). Concentrations of hydrocarbons in the gas phase initially were highest in the reactors containing the native microbial species without any surfactants (reactors 1 and 2) and the least in the poisoned control. But with time, the hydrocarbons present in the gaseous phase seemed to persist longest in the poisoned reactor, which was not easily explainable.

Removal of volatiles. Table 8 presents data on the removal of some of the volatile compounds present in the soil slurry. Data show that BTEX compounds were essentially all removed from the reactor (>99 percent) by volatilization as seen by the PID data. The removal of other volatiles such as chloroform, bromodichloromethane, acetone, and methylene chloride were highest in reactors 1 and 2 which had no surfactants. Apparently, the presence of surfactants reduced the volatilization of these compounds, as was observed

**Table 7
Bench-Scale Bioslurry Reactor Study—PID Headspace
Readings, Fort Sheridan Site**

Day	Average Values, ppm			
	Reactors 1 and 2	Reactors 3 and 4	Reactors 5 and 6	Reactors 7 and 8
0	12.5	7.5	7.5	3.0
1	2	4.5	1.0	1.5
2	2.5	4.0	0.5	2.5
5	3.0	4.0	0.2	3.0
6	2.5	3.5	0.1	2.0
7	0.1	1.5	0.0	2.5
8	0.1	1.0	0.0	1.6
9	0.1	0.1	0.1	2.0
12	0.1	0.1	0.0	0.5
13	0.05	0.05	0.0	1.6
14	0.05	0.05	0.05	2.0
15	0.05	0.0	0.05	1.2
16	0.0	0.05	0.0	0.6

in the TPH results. Many of the values reported in Table 8 were below detectable limits, which means that these numbers are not reliable. In addition to the compounds reported in Table 8, several other compounds (carbon disulfide, dibromomethene, trichloroethene, 2 butanone, and 4-methyl-2-pentanone) were found in low concentrations at time zero and at undetectable levels at day 16.

PAH removals. PAH compounds are not volatile except for naphthalene and other smaller molecular weight compounds. Hence, they are referred to as "semi-volatile" compounds. Thus, the disappearance of higher molecular weight PAH compounds in the bioslurry reactor would in all probability be due to biodegradation. Table 9 presents the PAH removals in the bioslurry reactors. Some loss of naphthalene and anthracene in the abiotic reactors (reactors 7 and 8) would suggest volatilization of these compounds. The higher removal of these compounds in the other biotic reactors would indicate biodegradation was active in these systems.

In general, the biotic systems (reactors 1 through 6) performed well for the two- and three-ringed PAHs. Removal of two-ringed naphthalene was >87 percent in these systems and as mentioned volatilization accounts for some removal of this compound. Removal of three-ringed anthracene was also very good (>91 percent). Here also, based on the high abiotic removal of this compound, it is possible some of the removal was due to volatilization, and the

**Table 8
Bench-Scale Bioslurry Reactor Study—Volatile Compounds Data, Soil Slurry, Fort Sheridan Site**

Compound	Average Concentrations, mg/kg											
	Reactors 1 and 2			Reactors 3 and 4			Reactors 5 and 6			Reactors 7 and 8		
	Day 0	Day 16	Percent Removal	Day 0	Day 16	Percent Removal	Day 0	Day 16	Percent Removal	Day 0	Day 16	Percent Removal
Benzene	0.43 ¹	ND	--	0.43 ¹	0.0001 ¹	99.7	0.43 ¹	0.024 ¹	94.4	0.43 ¹	0.011 ¹	97.4
Ethylbenzene	16.567	ND	--	16.567	0.00095 ¹	99.9	16.567	0.0061 ¹	99.9	16.567	0.041 ¹	99.7
Toluene	13.33	ND	--	13.33	0.0025 ¹	99.9	13.33	0.0088 ¹	99.9	13.33	0.036 ¹	99.7
Total xylene	106.67	ND	--	106.67	0.0065 ¹	99.9	106.67	0.029 ¹	99.9	106.67	0.25 ²	99.7
Chloroform	1.5	0.005 ¹	99.6	1.5	0.061	95.9	1.5	0.022	98.5	1.5	ND	--
Bromodichloromethane	1.5	0.0021 ¹	99.8	1.5	0.005 ¹	99.6	1.5	0.017 ¹	98.8	1.5	ND	--
Acetone	2.233 ^{1,2}	0.0295 ¹	98.6	2.233 ^{1,2}	0.215	90.3	2.233 ^{1,2}	0.073 ¹	96.7	2.233 ^{1,2}	0.097 ^{1,2}	95.6
Methylene chloride	2.033	0.06 ²	97.0	2.033	0.153 ²	92.4	2.033	0.145 ²	92.8	2.033	0.082 ²	95.9

Note: ND = Not detected.

¹ Values below detection limit.

² Detected in background samples.

Table 9
Bench-Scale Bloslurry Reactor Study—PAH Compounds Data, Fort Sheridan Site

Compound	Average Concentrations, mg/kg											
	Reactors 1 and 2			Reactors 3 and 4			Reactors 5 and 6			Reactors 7 and 8		
	Day 0	Day 16	Percent Removal	Day 0	Day 16	Percent Removal	Day 0	Day 16	Percent Removal	Day 0	Day 16	Percent Removal
Naphthalene	1.26	0.16 ¹	87.3	1.26	0.14 ¹	8.88	1.26	0.13 ¹	89.7	1.26	0.665 ¹	47.2
Anthracene	0.87 ¹	0.07 ¹	91.9	0.87 ¹	0.03 ¹	96.5	0.87 ¹	0.06 ¹	93.1	0.87 ¹	0.13 ¹	85.0
Benzo(k)fluoranthene	0.33 ¹	0.43 ¹	NR	0.33 ¹	0.255 ¹	22.7	0.33 ¹	0.265 ¹	19.6	0.33 ¹	0.33 ¹	0.0
Benzo(b)fluoranthene	0.42 ¹	0.56 ¹	NR	0.42 ¹	0.31 ¹	26.2	0.42 ¹	0.42 ¹	0.0	0.42 ¹	0.59 ¹	NR
Benzo(a)anthracene	0.37 ¹	0.325 ¹	12.1	0.37 ¹	0.32 ¹	13.5	0.37 ¹	0.345 ¹	6.7	0.37 ¹	0.44 ¹	NR
Pyrene	0.90 ¹	0.90 ¹	0.0	0.90 ¹	0.65 ¹	27.7	0.90 ¹	0.805 ¹	10.5	0.90 ¹	1.06 ¹	NR
Fluorene	0.10 ¹	0.05 ¹	50.0	0.10 ¹	0.02 ¹	80.0	0.10 ¹	0.55 ¹	45.0	0.10 ¹	0.14 ¹	NR
Fluoranthene	0.87 ¹	0.63 ¹	31.7	0.87 ¹	0.705 ¹	18.9	0.87 ¹	0.785 ¹	9.7	0.87 ¹	0.895 ¹	NR
Phenanthrene	0.68 ¹	0.41 ¹	39.7	0.68 ¹	0.165 ¹	75.7	0.68 ¹	0.31 ¹	54.4	0.68 ¹	0.80 ¹	NR
Chrysene	0.41 ¹	0.46 ¹	NR	0.41 ¹	0.35	14.6	0.41 ¹	0.365 ¹	10.9	0.41 ¹	0.48 ¹	NR
Benzo(a)pyrene	0.31 ¹	0.485 ¹	NR	0.31 ¹	0.255 ¹	17.7	0.31 ¹	0.32 ¹	NR	0.31 ¹	0.345	NR
Acenaphthene	0.06 ¹	ND	--	0.06 ¹	ND	--	0.06 ¹	0.07 ¹	NR	0.06 ¹	0.665	NR
Benzo(g,h,i)perylene	0.03 ¹	0.065 ¹	NR	0.03 ¹	0.025 ¹	16.6	0.05 ¹	ND	--	0.03 ¹	0.04 ¹	NR
Indeno(1,2,3-c,d)pyrene	0.08 ¹	0.04 ¹	50.0	0.08 ¹	0.02 ¹	75.0	0.08 ¹	0.04 ¹	50.0	0.08 ¹	ND	--

Note: ND = Not detected. NR = No removal.
¹ Below detection level.

rest due to biodegradation. For other three-ringed compounds, fluorene, phenanthrene, and acenaphthene removals were not as great (varied from 39.7 to 80 percent). No losses were observed for these compounds in the poisoned reactors (abiotic loss). Thus, these removals would be due to biodegradation in the reactors. The biodegradation of PAHs having four or more rings was lower (varied from no removal to 50 percent removal). Others have found slower biodegradation rates for the four- and higher ringed PAHs in petroleum sludges in aerobic treatment systems compared to the two- and three-ringed PAHs (Field and Wojtanowicz 1988). It should be mentioned that the 16 day run time used in these experiments was on the low side for the removal of higher molecular weight compounds. In unacclimated soils, the biodegradation $T_{1/2}$ of PAHs having more than three rings was reported to be greater than 30 days (Park, Sims, and Dupont 1990), while Sims, Sims, and Mathews (1989) reported that with acclimated cells, the $T_{1/2}$ for four-ringed benzo(a)pyrene was about 22 days.

Compared to the other biotic systems, the biodegradation of PAHs was better in the reactors containing 1.5 percent surfactant (reactors 3 and 4). This enhanced performance could be due to solubilization of the higher molecular weight PAHs, which generally have a low water solubility, which makes them available to the microbes for biodegradation. Addition of a higher surfactant dose of 3 percent did not improve the performance of the system. In fact, at times it was lower than the performance of the reactors without surfactants. These results are different from those observed for the Ninth Avenue Dump Superfund Site bench-scale study reported earlier, where the surfactants did not affect PAH removals. This discrepancy could be due to the fact that the surfactant doses were much lower (125 mg/L) in the Ninth Avenue Dump Superfund Site study as compared to this study.

It should be noted that many of the PAH values in Table 9 were below detection levels, which means that these readings may not be accurate. Thus, the data presented only give a relative comparison of the removal of the listed compounds.

Progress of biodegradation. Other parameters such as DO, pH, ammonia, phosphate, temperature, total solids, volatile solids, OURs, and growth of specific microorganisms were evaluated in the bioslurry reactors routinely in order to monitor conditions in the reactors and the progress of biodegradation.

It was desired to maintain DO values above 2.0 mg/L at all times. However, there were many instances where the DO level fell below 2.0 mg/L, especially in the reactors with surfactants (reactors 3, 4, 5, and 6). This occurred in one of the reactor pairs (not in both), which could only be explained by air supply restriction or diffuser clogging in that reactor. Lower DO levels could have affected the aerobic metabolism of the microbes in these reactors. The OUR data of the reactors did not provide any clue about the aerobic biodegradation rates, except the poisoned reactors justifiably had very low OUR data.

The pH of the reactors stayed within the range 6 to 8.2. The only exceptions were the reactors with 3 percent surfactant (reactors 5 and 6), where after 23 days the pH fell below 6.0, and eventually at 39 days it was 4.84. There was a general decline of pH with time in most of the biotic reactors as would be expected because of aerobic metabolism and CO₂ production. This trend was not evident in the abiotic reactors (reactors 7 and 8) where there was a slight increase of pH over time.

It was desired to provide sufficient ammonia nitrogen for microbial growth. Ammonium chloride solution was added on an "as needed" basis to maintain a 40-mg/L ammonia concentration. The reactors without surfactant (reactors 1 and 2) normally maintained fairly high ammonia levels, but ammonia levels in reactors with surfactant (reactors 3, 4, 5, and 6), on many occasions, fell below 1.0 mg/L. These low ammonia values indicated biological uptake by the microbes present in the reactors. It is unclear if low ammonia values affected the biodegradation rates of the reactors. The abiotic reactor had low ammonia levels (<2.0 mg/L) for the first 8 days, but eventually the levels increased to the 20- to 50-mg/L range. Fluctuations in phosphate concentrations occurred in several different reactors, but generally the levels were high enough to sustain biological activity.

The temperature in the reactors varied between 20 and 25 °C during the test period. Total solids were initially close to 30 percent, but with time there was a general decline of solids in all the reactors, including the poisoned reactors. The removal of the biodegradable components from the reactors would cause a decline in the total solids, but the growth of the microorganisms would partially compensate for the total solids loss. The percentage of volatile solids (VS) initially varied highly among different reactors. The average VS value for reactors 1 and 2 was 1.59 percent, but for reactors 5 and 6 it was 3.98 percent, with others in between. In the biotic reactors, the percent VS increased with time. The percent increase in VS was highest in reactors 5 and 6. The change in VS is often a measure of microbial growth in a bioreactor. Reactors 5 and 6 had the highest amount of surfactants present which could have solubilized some components present in petroleum hydrocarbons and allowed a higher microbial growth at the expense of these compounds. This would cause an increase in percent VS values with time. Additionally, the surfactants added could also biodegrade and contribute to an increase in biomass in the system, which would reflect in an increase of percent VS. There was a decline in percent VS in abiotic reactors (reactors 7 and 8) as expected. Some volatilization and solubilization of the contaminants would give a reduced percent VS with time.

Microbial enumerations of the reactor liquids confirmed the presence of cultures capable of good growth on nutrient agar and PTYG agar. The response of the three biotic reactor systems (reactors 1-6) was quite similar. Growth occurred rapidly through 8 days and then levelled off. The microorganism's numbers approached 10¹⁰/g soil with the growth media used in the reactors with the surfactants, and was somewhat less in the reactors without the surfactant (reactors 1 and 2).

Microbial examinations of the reactor contents were also made to determine the presence and growth of species capable of utilizing different compounds present in petroleum hydrocarbons. Cells were enumerated on basal salt agar in the presence of the specific compound. The compounds chosen for evaluation were BTEX, naphthalene, and phenanthrene. In the growth experiments, generally all cultures reached their peak growth values within 15 days and remained at that level for the rest of the incubation period of 36 days. Most growth (10^9 to 10^{10} CFU/g soil) was observed in samples from reactors 5 and 6, i.e., the reactors with 3 percent surfactant, somewhat less growth (10^8 to 10^9 CFU/g soil) in the reactors with 1.5 percent surfactants, and lowest growth (10^7 to 10^8 CFU/g soil) in the reactors without surfactants. Obviously, the presence of surfactant was beneficial for these species that degrade the compounds tested. Among the compounds tested, highest numbers were observed with toluene as the carbon source using samples from reactors 5 and 6. The growth patterns for the various species degrading these compounds were quite similar. Figures 12 and 13 show the growth of the microorganisms on basal salts agar with toluene and phenanthrene, respectively.

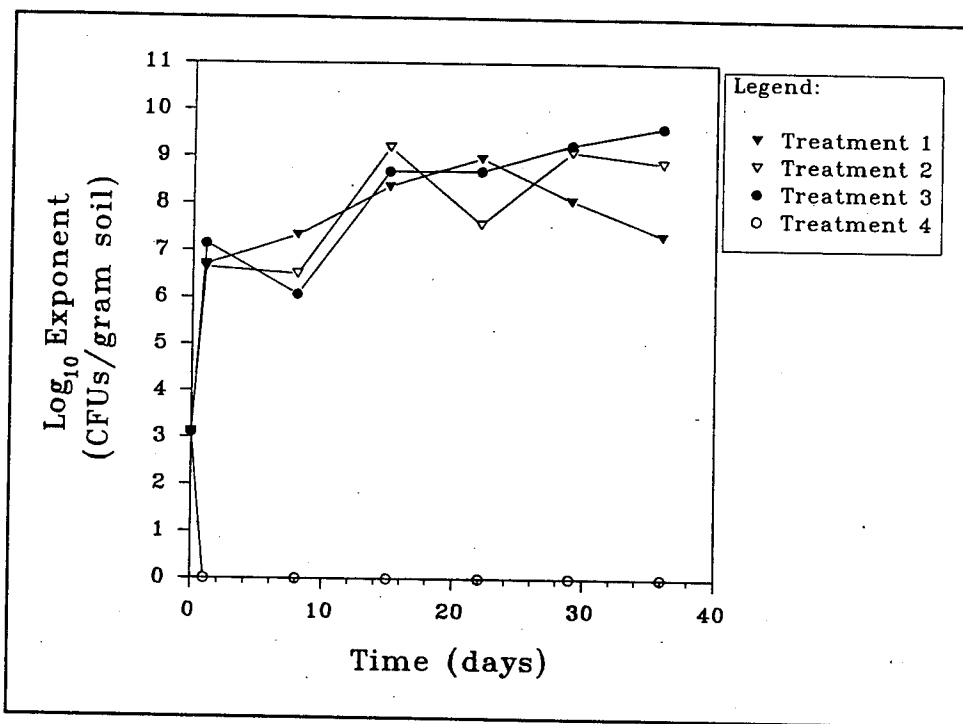

Figure 12. Bench-scale bioslurry reactor—microorganisms recovered on basal salt agar with toluene fumes, Fort Sheridan site

The following conclusions can be made from the results of this study:

- a. In the bioslurry reactors, the TPH removals were substantial (>80 percent), but these removals were possibly due to abiotic processes such as volatilization. The presence of high amounts of surfactant (reactors 5 and 6) retarded the removal of TPH significantly, possibly by

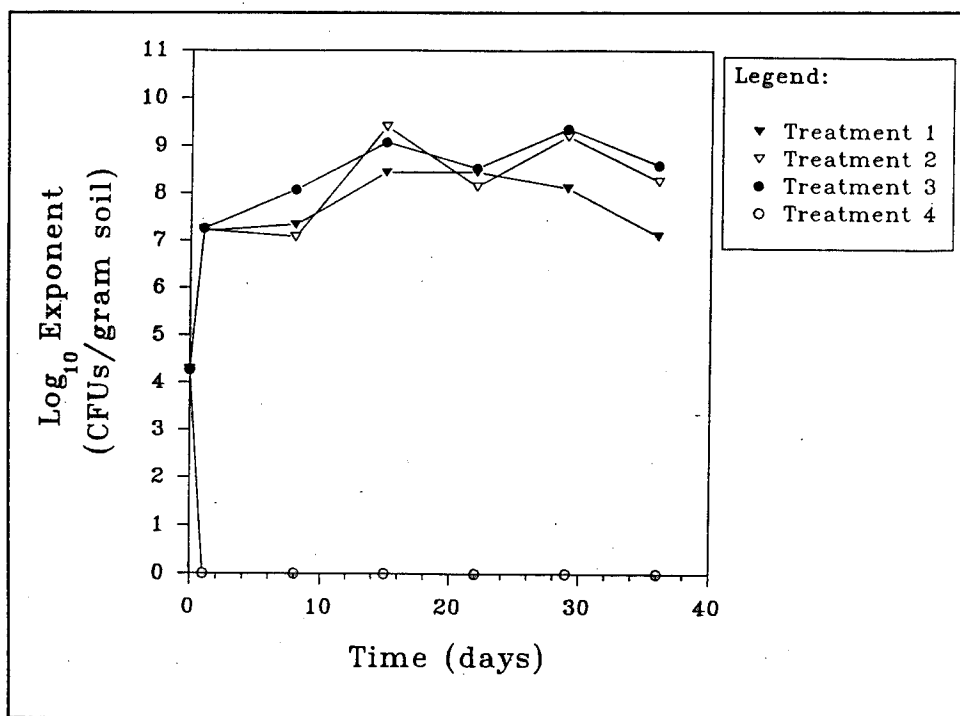

Figure 13. Bench-scale bioslurry reactor—microorganisms recovered on basal salt agar with phenanthrene fumes, Fort Sheridan site

reducing volatilization losses. PID data confirmed the high volatilization losses in these reactors

- b. The lack of a gas recirculation system in the reactors allowed the volatile components in the soil to be lost in the gaseous phase. This was clearly evident from the volatile compounds (BTEX and others) removal data. All reactors, including the abiotic (poisoned) reactors, showed very high removals of the volatile compounds. Presence of surfactants resulted in a somewhat reduced removal of these compounds compared to the reactors without surfactant.
- c. The two-ringed and some three-ringed PAH compounds were removed substantially by volatilization and biodegradation, while the higher ringed PAH removals were much lower in the 16 day test period. The presence of 1.5 percent surfactant in the reactor resulted in better PAH removals compared to the other systems.
- d. Microbial enumeration of the reactor contents confirmed the presence of bacteria capable of utilizing components in petroleum hydrocarbons present, such as BTEX, and some PAH compounds.
- e. The bench-scale data clearly showed the potential for bioslurry reactors to treat petroleum-contaminated soils.

Fort Sheridan Site, Pilot-Scale Evaluation

The bench-scale testing of contaminated soil from Fort Sheridan, IL, using bioslurry reactors provided positive evidence that biodegradation of TPH, PAH, and other compounds was feasible. The next step was to use a pilot-scale evaluation process to validate the treatment parameters for design of full-scale systems.

This pilot-scale study was conducted at WES using bioslurry reactors manufactured by EIMCO, Inc., Salt Lake City, UT.

Material and methods

Soils. The soils for the pilot-scale study were collected from a site in Fort Sheridan. The soils were selectively processed by hand to remove large debris and stones and then sieved through a No. 4 sieve (nominal opening of 4.75 mm) to remove remaining large solids.

EIMCO reactors. The same reactors as described earlier in the Ninth Avenue Dump Superfund Site pilot-scale studies were used except their capacities were 75 L. The reactors were modified at the upper end to include a foam-breaking system. The foam-breaking system was included to disperse excessive foams that were produced during the test. It consisted of an added chamber at the side of the reactor with a separate mixer. The concept of the foam breaker was that the foam would rise in this chamber and be dispersed by the mixer. Figure 14 shows the details of the modified reactor.

Three replicate reactors were set up with the composited soil to give a 30 percent soil-water slurry. Sufficient nutrients (N and P) were added to satisfy the microbial demand for degrading the petroleum hydrocarbon contaminants present in the soil. Temperature was maintained at 20 to 25 °C. Sufficient aeration was provided to maintain the DO levels in the reactors greater than 2.0 mg/L. The test was conducted for 62 days (January 19, 1992, to March 24, 1992).

The EIMCO exit gas recirculation system was built-in the bioslurry reactors. The system provided a means to prevent the loss of volatile components of the contaminants and improve the opportunity for biodegradation.

After 48 days of running the reactors and monitoring their performance, sodium acetate (66.73 g) was added to reactor 1, nonionic surfactant Tween 80 (66.73 g) to reactor 2, and a lower amount of sodium acetate (6.73 g) to reactor 3 to evaluate the difference in activity in these reactors.

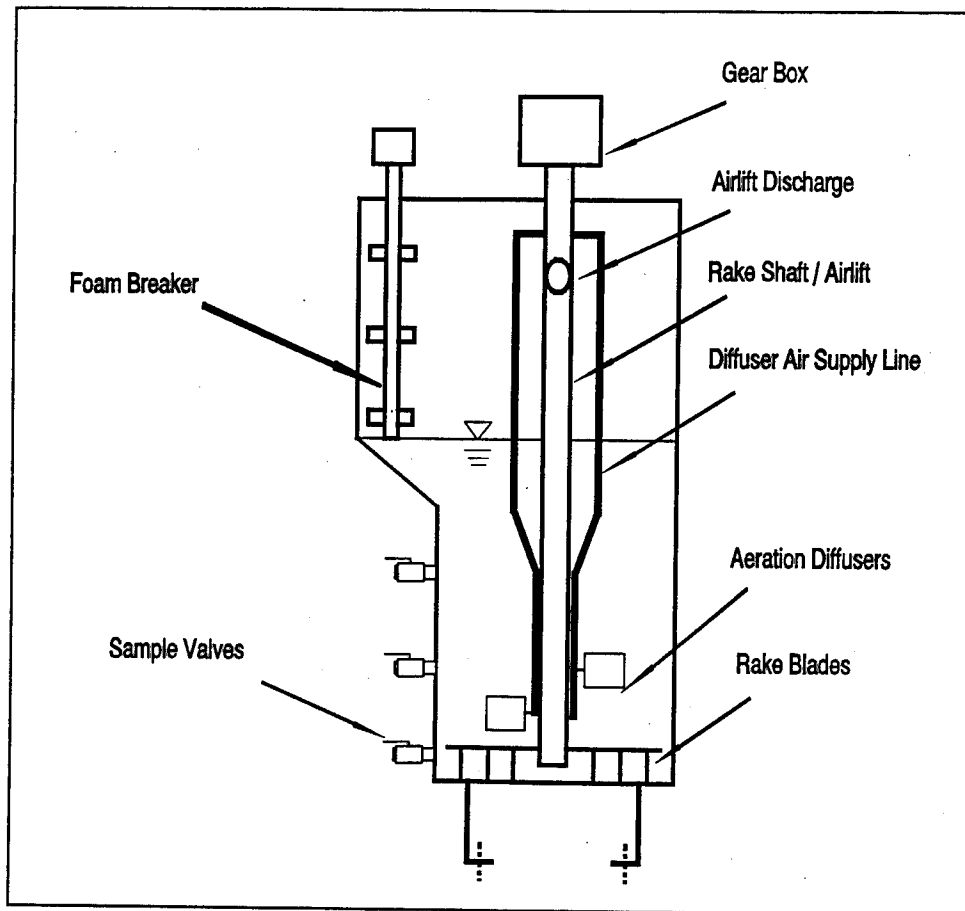

Figure 14. Modified bioslurry reactor with foam-breaker features

Sampling and analyses. Slurry samples were collected from the bottom and middle sampling ports of the reactors for analyses at the start of the experiment and during progression of the study.

These slurry samples were centrifuged to separate the soil from the aqueous phase. Both the soil and aqueous phases were analyzed for different petroleum hydrocarbon compounds. The analyses performed included total petroleum hydrocarbons, volatile compounds (BTEX, methylene chloride, chlorobenzene, acetone, butanone, 1,1,1 trichloroethane, chloroform, 2,hexanone), and PAH compounds.

These analyses were performed by either USEPA-approved methods (USEPA 1983, 1986) or Standard Methods (APHA 1989). As mentioned earlier, ammonia concentrations in the reactors were measured by selective ion probes (Orion 95-12 Probe/901 Ion Analyzer). The phosphate concentrations were determined by a Hach Kit PO-24. The microorganism enumeration procedures were also similar to those described previously for the Ninth Avenue Dump Superfund Site study.

Results

TPH removals. Table 10 shows the TPH removal data from the soil phase for the three bioslurry reactors. The percent TPH removals in the three replicate reactors varied from 82 to 68.6 percent in 27 days. In reactors 1 and 2 the concentration of TPH was reported as <25 mg/kg, which was the limit of detection. The percent removals for these reactors were based on the assumption that the day 27 values were half of 25 mg/kg, i.e., 12.5 mg/kg. Actually, the soil TPH level of <25 mg/kg in reactors 1 and 2 was reached in only 8 days of operation and remained at this level for the rest of the test period. The soil cleanup levels of <25 mg/kg are lower than the allowable level under the USEPA leaking underground storage tank clean-up guidelines of 50 to 500 mg/kg.

Reactor No.	Day 0	Day 27	Percent Removal
1	70	<25	82 ¹
2	70	<25	82 ¹
3	70	22 ²	68.6

¹ Calculated on the assumption that day 27 TPH values were half of 25 mg/kg.
² Below detection level of 25 mg/kg.

Table 11 shows the corresponding TPH levels in the aqueous phase of the slurry samples. The percent TPH aqueous phase removals in the three reactors were quite high (96.8 to 98 percent). The aqueous TPH value dropped sharply after two days to 1 to 2 mg/L and remained at <0.5 to 0.8 mg/L for the rest of the period in these reactors.

Reactor No.	Day 0	Day 27	Percent Removal
1	25	<0.5	98
2	25	0.5	98
3	25	0.8	96.8

Removal of volatiles. Table 12 shows the data of selected volatile components present in the soil phase of the samples. Removal of the BTEX compounds was very good (>97 percent) in a relatively short time (3 to 6 days) in all reactors. The removal of methylene chloride was also quite high (>93 percent), but the removals of acetone and 1,1,1 trichloroethane were less (50 to

**Table 12
Pilot-Scale Blossbury Reactor Study—Soil Phase Volatile Compounds Data (mg/kg), Fort Sheridan Site**

Compound	Reactor 1			Reactor 2			Reactor 3		
	Day 0	Day 6	Percent Removal	Day 0	Day 6	Percent Removal	Day 0	Day 6	Percent Removal
Benzene	0.16	0.0025 ¹ (3)	98.4	0.16 ¹	0.0079 ¹ (2)	95.0	0.16 ¹	0.0046 ¹ (3)	97.1
Toluene	1.3	0.0061 ¹ (3)	99.5	1.3	0.0017 ¹	99.8	1.3	0.0001 ¹	99.9
Ethylbenzene	0.35	0.0014 ¹ (3)	99.6	0.35	0.0034 ¹	99.0	0.35	0.0059(3)	98.3
T-xylene	19.0	0.013	99.9	19.0	0.0026 ¹	99.9	19.0	0.001 ¹	99.9
Methylene chloride	0.99 ²	0.04(27) ²	96.0	0.99 ²	0.03(27) ²	96.9	0.99 ²	0.067(27) ²	93.2
Acetone	0.4(1) ²	0.16 ¹ (27) ²	60.0	0.49(1) ²	0.18 ¹ (27) ²	63.2	0.24 ¹	0.092 ¹ (27) ²	61.6
1,1,1 trichloroethane	--	--	--	0.053 ¹	0.026 ¹ (3)	50.9	--	--	--
4 Methyl-2-pentanone	14	0.24 ¹ (2)	98.3	--	--	--	--	--	--

Note: () = Numbers in parentheses signify the sample day.

¹ Below detection level.

² Detected in background samples.

60 percent). These volatile component removals were due to biodegradation since the vapor recirculation system prevented release of any gaseous phases other than CO₂. It should also be noted that the concentrations of many of the compounds measured were below detection levels, which gives some uncertainty to these reported values. The actual concentrations of these volatile compounds after a few days of contact in the bioreactors were quite low.

Table 13 shows the aqueous phase concentrations of some volatile compounds present in the slurry samples. The concentrations of these compounds were below detection levels, which gives some uncertainty to the reported percent removals of these compounds. Nevertheless, except for 2-butanone in one of the reactors, there was fairly good removal of these compounds in the aqueous phase.

PAH removals. As indicated earlier, most of the PAH compounds are nonvolatile and have a limited water solubility. The removal of PAH compounds in these bioslurry reactors would be mostly due to biodegradation processes. Table 14 shows the PAH data for the reactors. Most PAH values are quite low and below the detection levels. There were several variations in the measured values of the individual compounds from day to day. The data mainly indicate some removal of these compounds even at these low levels.

Progress of biodegradation. The performance data for the reactors is shown in Table 15. Total suspended solids were fairly constant in the reactors (~30 percent) up to the 48th day, when sodium acetate or Tween 80 was added to the reactors. After that, solids gradually increased to about 36 percent at day 64. The volatile solids went up somewhat after the addition of the sodium acetate or Tween 80, but increases were modest.

The pH of the reactors decreased slightly after day 48 but remained in an appropriate range for biodegradation throughout the study. The NH₃ and phosphate levels fluctuated from day to day. More nutrients were added when ammonia or phosphate levels were low in order to maintain nutrient sufficiency.

The DO levels were high (>5 mg/L) in the reactors throughout the study. The OUR levels were higher initially, but levelled off to about 1.0 to 2.0 mg/L/hr and went up to 4 to 10 mg/L/hr after the addition of sodium acetate and Tween 80. This probably indicates biological degradation of the Tween 80 and sodium acetate.

Samples from the reactors were examined for microbial activity. Figure 15 shows the enumeration of microorganisms in the reactors that can grow on PTYG agar at various time periods. The numbers rose to greater than 10⁸/g soil in 7 days and remained near that level for the rest of the time period. The growth of phenanthrene utilizing bacteria in the reactors is shown in Figure 16. The phenanthrene utilizing bacteria reached their highest levels in the reactors after 14 days and remained at that level until about 35 days when the numbers declined slightly, possibly indicating reduced levels of

**Table 13
Pilot-Scale Biorreactor Study—Aqueous Phase Volatile Compounds Data (mg/L), Fort Sheridan Site**

Compound	Reactor 1			Reactor 2			Reactor 3		
	Day 0	Day 6	Percent Removal	Day 0	Day 6	Percent Removal	Day 0	Day 6	Percent Removal
Methylene chloride	0.009 ¹	0.0023 ¹ (27) ²	74.4	0.009 ¹	0.0035 ¹ (27) ²	61.1	0.009 ¹	0.0017 ¹ (27) ²	81.1
T-xylene	5.65	0.0023 ¹ (3)	99.9	--	--	--	--	--	--
Acetone	0.12 ¹	0.013 ¹	89.1	0.12 ¹	0.0067 ¹	94.4	--	--	--
2, Butanone	0.19 ¹ (1)	0.0016 ¹ (3)	99.1	0.16 ¹ (2)	0.12 ¹	37.5	--	--	--

Note: () = Numbers in parentheses signify the sample day.
¹ Below detection level.
² Detected in background samples.

**Table 14
Pilot-Scale Bioslurry Reactor Study—Soll Phase PAH Compounds Data (mg/kg), Fort Sheridan Site**

Compound	Reactor 1			Reactor 2			Reactor 3		
	Day 0	Day 34	Percent Removal	Day 0	Day 34	Percent Removal	Day 0	Day 34	Percent Removal
Naphthalene	1.1	0.13 ¹	88.1	1.1	0.26 ¹	76.3	1.1	0.25 ¹	77.3
Fluorene	0.07 ¹	--	--	0.07 ¹	0.04(2)	42.8	0.07 ¹	0.05 ¹ (5)	28.6
Phenanthrene	0.44 ¹	0.19 ¹	56.8	0.44 ¹	0.51 ¹	--	0.44 ¹	0.52 ¹	--
Anthracene	0.11 ¹	0.03 ¹	72.7	0.11 ¹	0.12 ¹	--	0.11 ¹	0.10 ¹	9.1
Fluoranthene	0.67 ¹	0.45 ¹	32.8	0.67 ¹	0.81 ¹	--	0.67 ¹	0.96 ¹	--
Pyrene	0.56 ¹	0.49 ¹	12.8	0.56 ¹	0.81 ¹	--	0.56 ¹	0.95 ¹	--
Chrysene	0.40 ¹	0.39 ¹	2.5	0.40 ¹	0.60 ¹	--	0.40 ¹	0.74 ¹	--
Benzo(a)anthracene	0.32 ¹	0.27 ¹	15.6	0.32 ¹	0.45 ¹	--	0.32 ¹	0.49 ¹	--
Benzo(k)fluoranthene	0.28 ¹	0.21 ¹	--	0.28 ¹	0.24 ¹	14.3	0.28 ¹	0.42 ¹	--
Benzo(b)fluoranthene	0.19 ¹	0.29 ¹	--	0.19 ¹	0.50 ¹	--	0.19 ¹	0.62 ¹	--

Note: () = Numbers in parentheses signify the sample day.
¹ Below detection level.

Table 15

Pilot-Scale Bloslurry Reactor Study—Reactor Operating Data, Fort Sheridan Site

Days	Reactor No.	TSS, %	VSS, %	pH	NH ₃ , mg/L	Phosphate as PO ₄ , mg/L	DO, mg/L	OUR, mg/L/hr
2	1	32.0	2.55	7.88	7.33	2.04	8.72	4.02
	2	30.4	2.85	7.79	5.45	3.32	8.43	1.80
	3	30.2	2.81	7.82	6.03	1.71	8.20	2.04
13	1	31.9	2.58	7.65	138	1.63	9.57	2.64
	2	31.5	2.72	7.61	116	1.59	9.15	2.10
	3	30.5	2.89	7.62	100	1.84	8.87	0.96
22	1	31.1	2.90	7.58	54.5	1.72	9.10	1.62
	2	30.1	3.01	7.55	53.4	2.29	8.58	0.96
	3	31.1	3.07	7.57	65.0	2.01	8.37	0.96
36	1	30.5	3.04	--	52.3	1.46	--	--
	2	30.5	3.00	--	73.4	1.88	--	--
	3	29.6	3.07	--	16.4	1.45	--	--
45	1	33.1	2.65	7.96	6.79	--	5.30	5.52
	2	30.4	2.92	7.24	1.09	--	8.72	2.46
	3	30.8	3.00	7.19	44.2	--	8.73	1.98
48	1	--	--	7.67	--	3.14	7.72	12.24
	2	--	--	6.98	--	1.98	8.12	2.16
	3	--	--	6.99	--	1.94	7.89	5.04
50	1	35.9	3.18	7.43	--	--	8.27	4.44
	2	33.9	3.34	6.86	--	--	8.05	2.16
	3	34.3	3.32	7.01	--	--	8.01	5.04
64	1	36.2	2.72	7.74	12.5	4.27	6.41	17.4
	2	35.2	3.48	6.57	34.1	2.99	8.02	4.74
	3	36.3	3.28	6.33	30.8	4.28	7.50	5.64

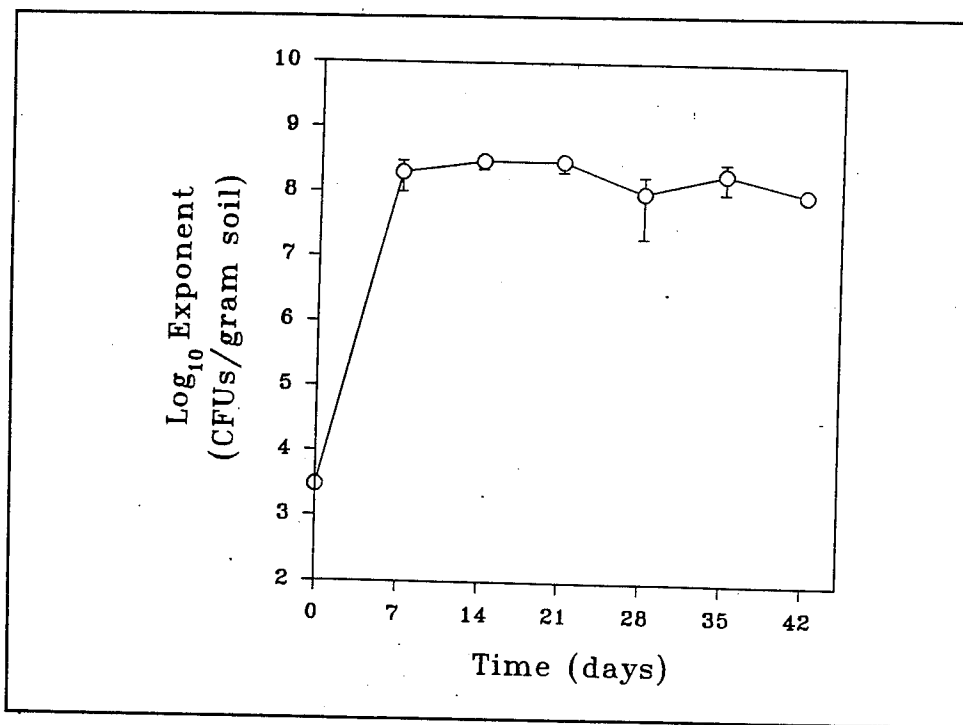

Figure 15. Pilot-scale bioslurry reactor—microorganisms recovered on PTYG agar, Fort Sheridan site

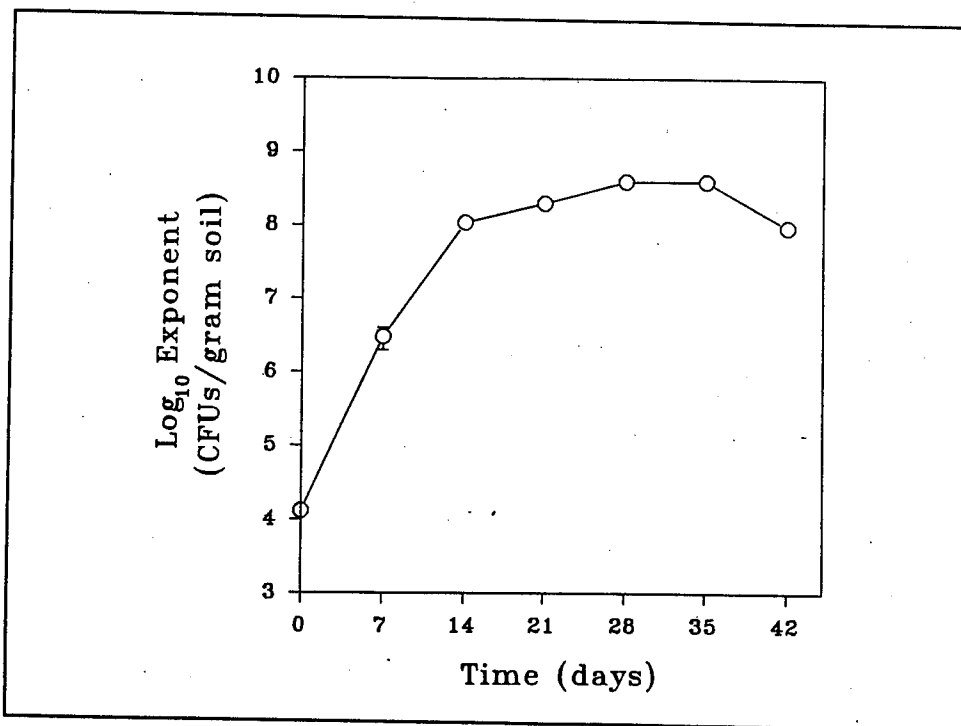

Figure 16. Pilot-scale bioslurry reactor—microorganisms recovered on basal salt agar with phenanthrene fumes, Fort Sheridan site

substrate presence. The pattern of growth of the microorganisms that utilize BTEX compounds in the reactors was slightly different from that described above. Figure 17 shows the growth of organisms in the reactors that utilize toluene. The drop in the numbers of microorganisms utilizing toluene on the 31st day was also observed with all other BTEX compounds, and the general trend for growth of all BTEX compounds in the reactor was similar to that shown in Figure 17.

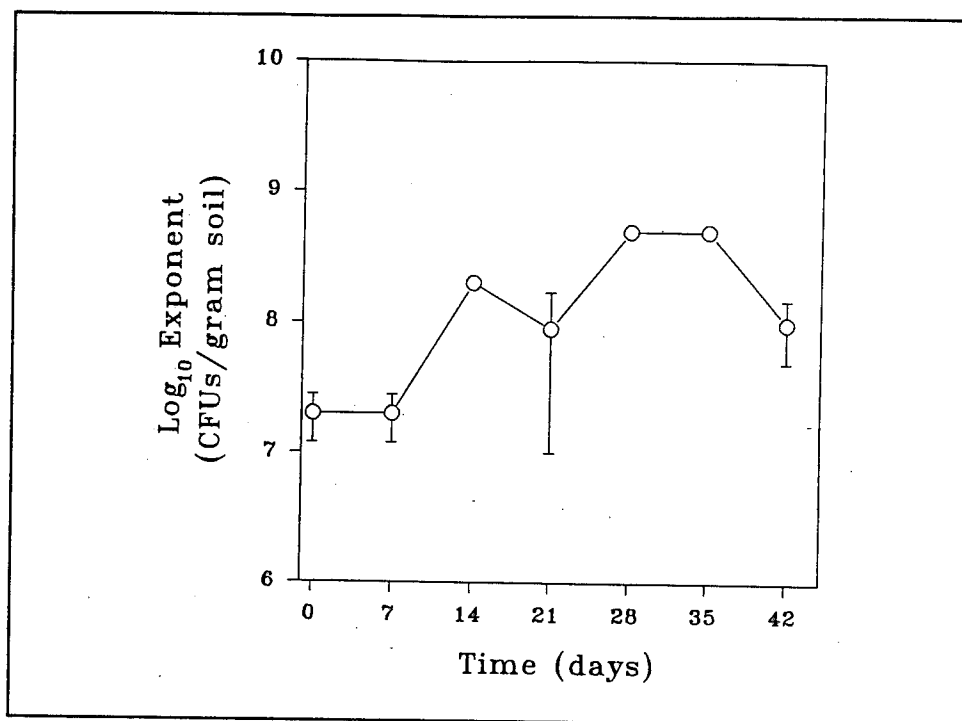

Figure 17. Pilot-scale bioslurry reactor—microorganisms recovered on basal salt agar with toluene fumes, Fort Sheridan site

The following conclusions can be made from the results presented:

- a. The soil TPH levels achieved after about 8 days in the bioslurry reactors were <25 mg/kg, a value that is below the 50- to 500-mg/kg level allowed by EPA leaking underground storage tank clean-up guidelines.
- b. Levels of volatile compounds in both the soil and aqueous phase were low after about 6 days of treatment, indicating biodegradation of these compounds, despite the low initial concentrations of some compounds.
- c. PAH removals occurred to some extent. The initial and final concentrations in the soil phases for many compounds were below detection levels, which makes these data questionable.
- d. Over time, the reactors had substantial numbers of microorganisms ($>10^8$ /g soil) capable of growing on PAH or BTEX compounds.

Summary

Results of the two bench- and pilot-scale bioslurry reactor soil remediation studies indicate that:

- a.* Native microbial species present in the contaminated soil can biodegrade TPH, volatile organics (BTEX), and PAH compounds to low residual values in a reasonable amount of time.
- b.* The vapor recirculation feature in the reactors provides a longer contact time between volatile compounds and microorganisms and increases biodegradation. The volatile compounds in the soil phase decrease to very low values in 10 to 14 days.
- c.* PAH compounds were removed reasonably well (>65 percent) when initial concentrations were high (in the range of 1 to 10 mg/kg), but the removals were uncertain when initial concentrations were below detection levels.
- d.* Addition of 1.5 percent nonionic surfactants may improve the removal of PAH compounds to some extent, but it retards the removal of TPH; therefore, the addition of surfactants may or may not be beneficial, depending on the source of contamination.
- e.* Maintenance of N, P, and pH in the reactor at suitable levels can be easily controlled by periodic monitoring and addition of chemicals.
- f.* Maintenance of DO at levels >2 mg/L by aeration and mixing in these reactors at the loading rates used was not a problem.

4 Design and Cost Estimates

The results of the bench- and pilot-scale studies presented in the earlier section showed that bioslurry reactors with vapor recirculation can treat soils contaminated with petroleum hydrocarbons at different levels in a reasonable amount of time.

The next step involves designing the bioslurry reactor system for remediation of sites that contain soils contaminated with petroleum hydrocarbons and determining the costs for such systems.

Process Concepts

Conceptual designs have been made for five contaminated soil volumes (1,500, 5,000, 10,000, 20,000, and 50,000 cu yd). The scenario envisions excavation of the contaminated soil and its transportation to a process area where it will be screened through No. 4 and No. 20 mesh screens. Particles retained on these screens will be discarded and returned to the site. Only the particles passing the No. 20 screen will be treated in the bioslurry reactor. These particles will be combined with water and nutrients (N and P) in a mixing tank to give an approximate solid concentration of 40 percent (w/w) before pumping into the bioslurry reactor. The bioslurry reactor will be equipped with mixing, aeration, and vapor recirculation system. After treatment in the bioslurry reactors, the soil slurry will be dewatered. Two types of soil dewatering systems will be considered: centrifugation (low g solid bowl type) and sand drying beds. A schematic for the bioslurry process is shown as Figure 18.

The vapors emanating from the bioslurry reactor will be recirculated through the reactor, which will facilitate the degradation of the volatile compounds present. No provisions are made for vapor emission controls from the mixing tanks or the screening process. It is expected that these emissions will be small.

The final disposal of the treated dewatered soil will depend on the residual TPH level. Soils with TPH levels less than 50 mg/kg may be land applied in most locations. If the soil TPH level is greater than 50 mg/kg, depending on

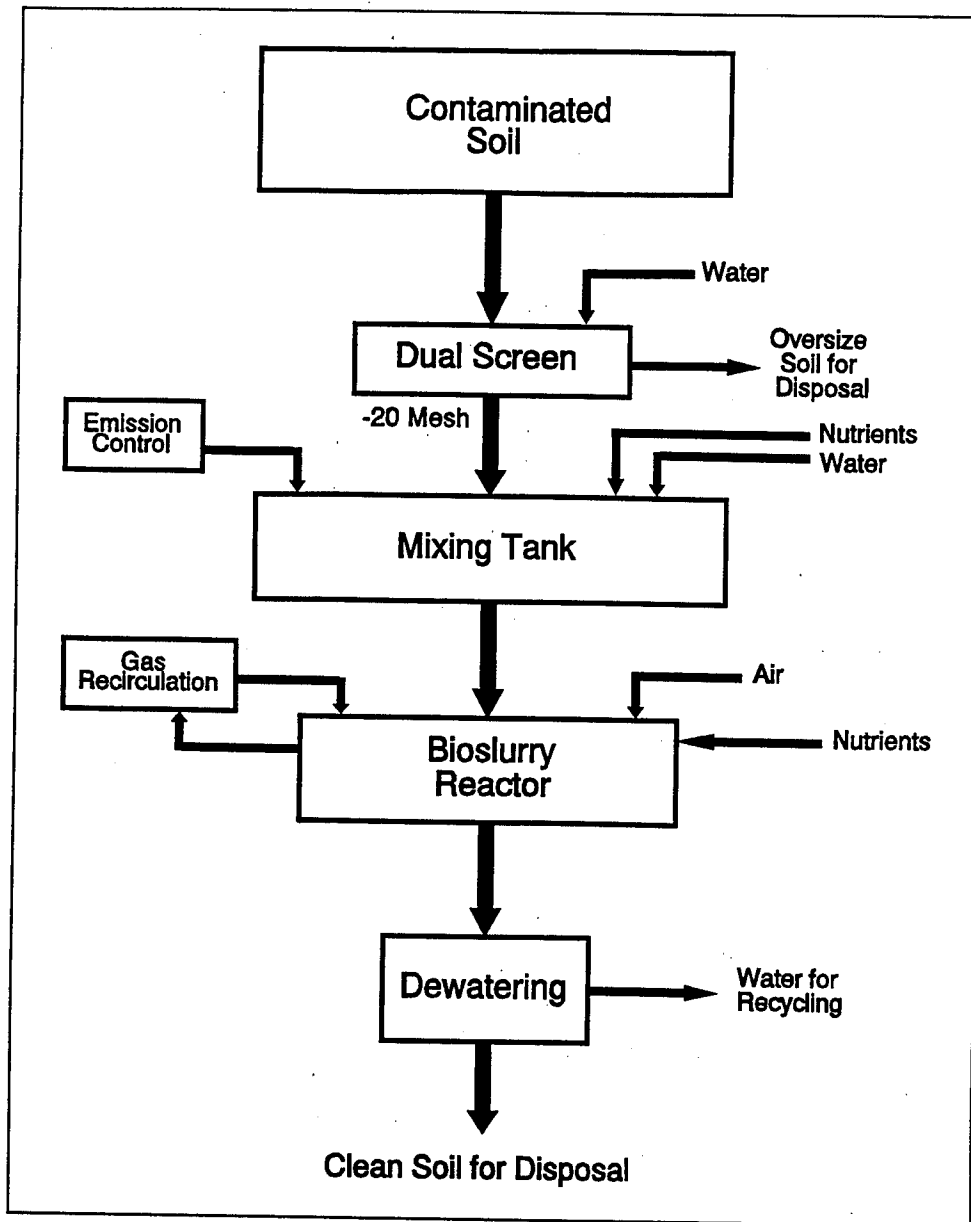

Figure 18. Schematic of bioslurry process for remediating contaminated soil

local restrictions, it can be land treated to further reduce the TPH levels, or it can be landfilled at an approved site. The aqueous phase TPH from the treated soil slurry is expected to be low, but discharge to stream may not be feasible. The aqueous phase derived from the dewatering step can be recycled through the process or it can be discharged to a nearby publicly owned treatment works, or a sewer system if that is permitted.

Process Design

As seen in Figure 18, the bioslurry process consists of the following units:

- Screens
- Mixing tank(s)
- Bioslurry reactor(s)
- Dewatering equipment

The sizing of this equipment is discussed in the following paragraphs.

Screens

The screening operation will consist of two screens: a coarse screen (No. 4) followed by a finer screen (No. 20). The screens will be inclined type with the rejects collected in a side tray, and the fines from the last screen will be transferred to the mixing tank. The screen sizes are determined on the basis of processing the volume of soil fed to the bioslurry reactor in 2 days (16 hr). For instance, the screen throughput for the 500,000-gal bioslurry reactor requiring 470 cu yd of soil will be about 30 cu yd/hr. The screens will be loaded using a mobile conveyor system having an inlet hopper at the bottom where the contaminated soil will be introduced by a front-end loader. The screen rejects will be collected from the side trays and transported back to the site. The approximate bank volume of the fine materials passing the No. 4 screen will be calculated from the dimensions of the piled material. These data will be used for calculating the feed solids to the bioslurry reactors.

Mixing tank

The fines from the No. 4 screen will be transferred into the mixing tank using a mobile inclined conveyor system similar to the one used for the screens. The mixing tank will be an aboveground painted mild steel tank having the same capacity as the bioslurry reactors (300,000 or 500,000 gal). The mixing tank will have a 75-hp mixer to keep the soil in suspension. The tank will be fabricated in the factory, transported to the field in parts, and field erected on a concrete pad. The amount of soil added each time for mixing will be about 250, 270, or 450 cu yd, depending on the amount of total soil being remediated and the size of the mixing tank (see Appendix A) to form a 40 percent slurry with water. Nutrients (N and P) required for the biodegradation process will be added to the mixing tank. The soil slurry will be pumped from the mixing tank to the bioslurry reactor(s) using pumps that can handle slurry materials. These pumps should be able to transfer the soil slurry to the reactors in less than a day.

Bioslurry reactors

The bioslurry reactors will be similar in design as those manufactured by EIMCO Corporation, Salt Lake City, UT. They will be equipped with an air lift mixing, aeration, and vapor recirculation system.

The process involves aerobic degradation of contaminants by the indigenous microorganisms present in the soil. The amounts of nutrients (N and P) required will depend upon the amount and type of contaminants present. The biodegradable C, N, and P generally should be on the weight basis 120:10:1 (Sims, Sims, and Mathews 1989). The calculated amounts of N and P sources (NH_4NO_3 and superphosphate) required for different volumes of contaminated soil remediation, based on a total C loading of 6.05 g/kg soil (3 percent oil fraction in soil pores), are presented in Appendix A. In practice, routine monitoring of the liquid phase will be conducted, with nutrient (NH_4NO_3 and superphosphate) additions made when N and P levels fall below 10 and 2 mg/L, respectively. Nutrient additions can be made to the mixing tank or the bioslurry reactor by metering pumps from solution tanks of NH_4NO_3 and superphosphate. The chemical metering pump sizes will be small since these compounds can be made into concentrated solutions.

According to the information available from one of the vendors (EIMCO Corporation), 300,000 gal is the largest tank size available, with possibly up to 500,000-gal size feasible to manufacture. Thus, the design calculations have been made based on these sizes. These reactors would be fabricated in the factory, transported in parts, and field erected at the site on a concrete pad.

The target TPH level of the treated soil has been selected at 50 mg/kg soil, which is the lower limit of allowable values under the USEPA's leaking underground storage tank clean-up guidelines.¹ The remediation time and percent removal will vary depending on the type of contaminant (gasoline, diesel oil, aged petroleum product, etc.). Based on the results of bench- and pilot-scale studies with lightly contaminated soils (TPH <200 mg/kg soil, Fort Sheridan), the bioslurry process could treat the soil to the target TPH levels of 50 mg TPH/kg soil in less than 20 days. For a highly contaminated soil (Ninth Avenue Superfund Site with TPH levels >7,000 mg/kg soil), it took 30 days to reduce the TPH levels to around 2,000 mg/kg soil using the bioslurry process.

The design total detention time in the bioslurry reactor is chosen to be 45 to 50 days based on the results of studies reported herein and literature information for the range of TPH values considered. For sites with high levels of TPH, the detention time in the bioslurry reactor may need to be higher than 45 to 50 days in order to reach the desired TPH levels. For many sites the regulated TPH values of the treated soils may be higher than 50 mg/kg with the result that the degree of treatment and required detention time may be different from what is presented herein.

¹ Personal Communication, June 1993, Bill Peterson, USEPA, Region VII, Kansas City, KS.

Two process alternatives for bioslurry treatment evaluation have been considered for the soil volumes selected in this report. Alternative 1 involves three bioslurry reactors-in-series (cascade), each having a detention time of 15 days; Alternative 2 considers one large or two parallel bioslurry reactors, each with an overall detention time of 50 days. The calculations for the time required to complete the treatment of the five soil volumes considered for treatment are presented in Appendix A. For example, for the soil volume of 20,000 cu yd in Alternative 1, 600 days would be needed to complete the treatment using three 300,000-gal cascading reactors, while in Alternative 2, 1,115 days would be required, using two 500,000-gal reactors in parallel.

Dewatering equipment

In some instances for slurries with high solids concentration, it may be acceptable to apply the slurry after treatment on a prepared land surface without any dewatering. The moisture present in the soil will then be lost slowly by evaporation. The decision to land apply will be site and area specific, depending on the local and state requirements. If acceptable, this method may provide substantial cost savings. Alternatively, dewatering techniques such as the one mentioned below may be used.

For this case study, two dewatering methods are evaluated: open sand drying beds and centrifugation.

Sand drying beds are the simplest and most cost-effective option for dewatering slurries, but they require more land and are labor intensive. It is expected that soils should dewater to about 60 percent solids concentration in a few weeks. Solids loading rates of 100 lb/sq ft/year are used for the design of the open sand drying beds. The sand drying bed option has been considered with Alternative 2 for the bioslurry process. Appendix A shows the calculations for determining the land area for the sand drying beds for the five soil volumes considered for treatment. The area required for dewatering will be 47,300 sq ft for the smallest soil volume (1,500 cu yd) and 180,200 sq ft for the largest soil volume (50,000 cu yd). The dewatered soil can be scraped from the beds for disposal. The drained liquid can be recycled in the treatment process, or can be discharged into a sewer system if permissible.

The centrifugation option can also be considered for dewatering the treated slurry, although little literature data exist on solids dewatering at high solids concentration. This process is quite sophisticated and requires skilled operation and maintenance. It does require less space compared to other dewatering processes but is more energy intensive and requires a covered building. For design purposes, it is assumed that the centrifuge will dewater the slurry solids to >50 percent solids concentration, and calculations have been performed for centrifugation as the dewatering process with Alternative 1. The treated slurry from the bioslurry reactor will be transferred to a storage tank, which will be constantly mixed to keep the solids in suspension. The size of the storage tank will be the same as the mixing tanks (300,000 or 500,000 gal). The soil slurry

from the storage tank will be transferred to a solid-bowl centrifuge by a pump capable of handling high solids.

The throughput from the solid bowl centrifuge (low g) will be 100 gpm for the treatment of soil volumes up to 20,000 cu yd and 200 gpm for the largest soil volume of 50,000 cu yd. The bioslurry reactors will discharge treated soil slurry every 15 days to the storage tank. The centrifuge will have to process this slurry volume before the next batch is received in 15 days. The centrifuge operation period will vary from 37 hr for the smallest soil volume treated to 66 hr for the largest soil volume system. The solids discharged from the centrifuge will be sent to the disposal site, and the centrate will be recycled in the process or discharged into a sewer system if permissible.

Cost Estimates

One of the important aspects of remediation of contaminated soil is the evaluation of realistic cost of the entire process. Once such a cost is available, to ensure that the best decisions on treatment options are made, cost comparisons can be made with alternative processes having similar contaminant removal and treatment times.

Costs were estimated for the bioslurry process to treat the five selected contaminated soil volumes. The cost factors included were as follows:

a. Capital costs (including installation).

- (1) Screens.
- (2) Mixing tanks.
- (3) Bioslurry reactors with aeration, mixing, and vapor recirculation equipment.
- (4) Transfer and metering pumps.
- (5) Process monitoring equipment.
- (6) Dewatering equipment.

b. Operating costs.

- (1) Labor.
- (2) Energy.
- (3) Chemicals.
- (4) Health and safety.

- (5) Analytical.
- (6) Repair and maintenance.

c. *Other costs.*

- (1) Site mobilization and demobilization.
- (2) Site preparation.
- (3) Treated soil and process water disposal.

As suggested earlier, the cost of vapor recirculation equipment in the bioslurry reactor has been included in the estimate presented, but the cost of vapor emission control from the mixing or storage tank or the screens has not. In cases where the volatile emissions from the mixing tank, the storage tank, or the screening operation exceed the local allowable limits, emission control measures will be needed and such costs should be included.

As was indicated in the Process Design section, two alternative bioslurry systems have been considered. The first uses a series (cascade) of three bioslurry reactors with centrifugation for dewatering the treated slurry. The second alternative uses a single (or two parallel) bioslurry reactors with sand drying beds for dewatering the slurry. The time needed to complete the remediation is much shorter in Alternative 1 than in Alternative 2.

Table 16 shows the cost breakdown for Alternative 1 for the five soil volumes treated. The costs of screens are extrapolated from quotations from Wire Cloth Manufacturing Company. Costs for the mobile inclined conveyor system are included. The mixing tank costs are based on painted mild steel tanks with mixer. The bioslurry tank costs are based on information provided by EIMCO Corporation. Costs for the concrete pads for the tanks are included. The dewatering centrifuge capital and operation costs are from USEPA (1982). The costs reported in the manual have been updated to October 1993 using the *Engineering News Record Cost Index*. Other capital costs have been estimated based on time and materials needed for the job. It is assumed that the salvage value for mechanical equipment is half the original cost.

The operation costs are based on the following unit costs:

Labor	\$ 50/hr
Electrical energy	\$ 0.08/kW·hr
Chemicals-	
NH ₄ NO ₃	\$ 205/ton
Superphosphate	\$ 250/ton

Table 16
Alternative 1: Costs for Bioslurry Treatment of Contaminated Soils
(40% slurry, three cascading bioslurry reactors, and centrifugation for dewatering)

Cost Item	Volume of Soil, cu yd				
	1,500	5,000	10,000	20,000	50,000
Construction Costs					
Excavation @ \$5/cu yd	\$7,500	\$25,000	\$50,000	\$100,000	\$250,000
Screens	7,000	7,000	9,000	11,000	13,000
Mixing tank	180,000	180,000	360,000	360,000	600,000
Bioslurry reactor with concrete pads	1,575,000	1,575,000	3,150,000	3,150,000	5,050,000
Nutrient feed system	5,000	5,000	10,000	10,000	20,000
Dewatering centrifuge with storage tank	521,800	521,800	546,800	546,800	756,000
Site mobilization and demobilization	15,000	15,000	25,000	35,000	65,000
Site preparation	10,000	10,000	15,000	20,000	40,000
Transfer pumps and piping	5,000	5,000	10,000	20,000	40,000
Subtotal	\$2,326,300	\$2,343,800	\$4,175,800	\$4,432,800	\$6,834,000
Less 50% salvage value (reactors, tanks, centrifuge, etc.)	\$1,103,400	\$1,103,400	\$1,958,400	\$1,958,400	\$3,088,000
Net costs	\$1,222,900	\$1,240,400	\$2,217,400	\$2,294,400	\$3,746,000
Operating Costs					
Labor @ \$50/hr	\$35,000	\$86,750	\$111,750	\$225,000	\$420,000
Energy @ 8¢/kW·hr	101,800	254,700	494,400	1,065,300	2,306,500
Chemicals	600	1,800	3,600	7,200	18,000
Sampling and analyses	4,500	11,250	22,500	45,000	90,000
Repair and maintenance	5,000	7,500	10,000	20,000	40,000
Net costs	\$146,900	\$362,000	\$642,250	\$1,362,500	\$2,874,500
Construction + operating costs	\$1,369,800	\$1,602,400	\$2,859,650	\$3,656,900	\$6,620,500
Contingency (10%)	136,980	160,240	285,960	365,690	662,050
Grand total	\$1,506,780	\$1,762,640	\$3,145,610	\$4,022,590	\$7,282,550
Unit cost, \$/cu yd	\$1,004	\$353	\$315	\$201	\$146

The energy and labor requirements for each alternative are detailed in Appendix B.

The unit cost (\$/cu yd) for the decontamination of the soil decreases drastically as the total volume of soil treated goes up. The estimated cost per cubic yard for treating 50,000 cu yd of contaminated soil is \$146 for this alternative.

Table 17 shows the cost breakdown for Alternative 2 for the different soil volumes treated. The costs of various items in this alternative are obtained in the same way as in Alternative 1 (except the costs for sand drying beds, which are from the USEPA (1982) publication). Details of energy and labor requirements are given in Appendix B. Unit costs for this alternative are lower for the smaller soil volumes treated as compared to Alternative 1; however, when soil volumes are >20,000 cu yd, Alternative 1 becomes more cost effective. It should be noted that the time required for clean-up is much higher in Alternative 2 than in Alternative 1 for all soil volumes considered.

For either alternative, for treating soil volumes greater than 20,000 cu yd, the unit cost per cubic yard will be \$150 to \$200.

Table 17
Alternative 2: Costs for Bioslurry Treatment of Contaminated Soils
(40% slurry, single bioslurry reactor, and sand drying bed for dewatering)

Cost Item	Volume of Soil, cu yd				
	1,500	5,000	10,000	20,000	50,000
Construction Costs					
Excavation @ \$5/cu yd	\$7,500	\$25,000	\$50,000	\$100,000	\$250,000
Screens	7,000	7,000	9,000	11,000	13,000
Mixing tank	180,000	180,000	360,000	360,000	600,000
Bioslurry reactor with concrete pads	525,000	525,000	525,000	1,650,000 (2 Reactors)	1,650,000 (2 Reactors)
Nutrient feed system	5,000	5,000	5,000	10,000	20,000
Sand drying beds	242,000	262,200	262,200	690,000	773,000
Site mobilization and demobilization	15,000	15,000	25,000	35,000	65,000
Site preparation	10,000	10,000	15,000	20,000	40,000
Transfer pumps and piping	5,000	5,000	5,000	20,000	40,000
Subtotal	\$996,500	\$1,034,200	\$1,241,200	\$2,896,000	\$3,451,000
Less 50% salvage value (reactors, tanks, centrifuge, etc.)	\$342,500	\$342,500	\$432,500	\$985,000	\$1,110,000
Net costs	\$654,000	\$691,700	\$808,700	\$1,911,000	\$2,341,000
Operating Costs					
Labor @ \$50/hr	\$70,000	\$200,000	\$395,000	\$660,000	\$1,727,500
Energy @ 8¢/kW-hr	116,500	359,310	710,450	909,900	90,000
Chemicals	600	1,800	3,600	7,200	18,000
Sampling and analyses	4,500	11,250	22,500	45,000	90,000
Repair and maintenance	5,000	7,500	10,000	20,000	40,000
Net costs	\$196,600	\$579,860	\$1,141,550	\$1,642,100	\$5,032,700
Construction + operating costs	\$850,600	\$1,271,560	\$1,950,250	\$3,553,100	\$7,373,700
Contingency (10%)	85,060	127,150	195,020	355,310	737,370
Grand total	935,660	\$1,398,710	\$2,145,270	\$3,908,410	\$8,111,070
Unit cost, \$/cu yd	\$623	\$280	\$214	\$195	\$162

References

- American Public Health Association. (1989). "Standard methods for the examination of water and wastewater," 17th ed., Washington, DC.
- Banerjee, S., Howard, P. H., Rosenberg, A. M., Dombrowski, A. E., Sikka, H., and Tullis, D. L. (1984). "Development of a general kinetic model for bio degradation and its application to chlorophenols and related compounds," *Environ. Sci. Tech.* 18(6), 416-422.
- Bartha, R. (1986.) "Biotechnology of petroleum pollutant biodegradation," *Microbial Ecology* 12, 155-172.
- Borquin, A. W. (1989). "Bioremediation of hazardous wastes," *Hazardous Materials Control* 2(5), 16-58.
- Brown, L. R. (1987). "Oil-degrading microorganisms," *Chem. Engr. Progress*, 35-40.
- Brox, G. H., and Hanify, D. E. (1989). "A new solid/liquid contact bioslurry reactor making bio-remediation more cost-competitive." *Colorado Hazardous Waste Management Society Conference*. Denver, CO.
- Bury, S. J., and Miller, C. A. (1993). "Effect of micellar solubilization on biodegradation rates of hydrocarbons," *Environ. Sci. Tech.* 27(1), 104-110.
- Castaldi, F. J., and Ford, D. L. (1992). "Slurry bioremediation of petrochemical waste sludges," *Water Sci. Tech.* 25(3), 207-212.
- Cerniglia, C. A. (1984). "Microbial metabolism of polycyclic aromatic hydrocarbons." *Advances in Applied Microbiology*, 30, A. I. Laskin, ed., Academic Press, Orlando, FL.
- Chiang, C. Y., Salanitro, J. P., Chai, E. Y., Colthart, J. D., and Klein, C. L. (1989). "Aerobic biodegradation of benzene, toluene, and xylene in a sandy aquifer—Data analysis and computer modeling," *Ground Wat.* 27(6), 823-834.

- Deeley, G. M., Skierkowski, P., and Robertson, J. M. (1985). "Biodegradation of (¹⁴C) phenol in secondary sewage and landfill leachate measured by doublevial radiorespirometry," *Appl. Environ. Microbiol.* 49(4), 667-869.
- Dibble, J. T., and Bartha, R. (1976). "Effect of environmental parameters on the biodegradation of oil sludge," *Appl. Environ. Microbiol.* 37(4), 729-739.
- Ellis, W., Payne, J., and McNabb, J. (1986). "Treatment of contaminated soils with aqueous surfactants," EPA/600/2-85/129, Hazardous Waste Research Laboratory, USEPA, Cincinnati, OH.
- Falatko, D. M., and Novak, J. T. (1992). "Effects of biologically produced surfactants on the mobility and biodegradation of petroleum hydrocarbons," *Water Environ. Res.* 64(2), 163-169.
- Field, S. D., and Wojtanowicz, A. K. (1988). "Biological treatment of petroleum sludges." *Proceedings 2nd Annual Symposium on Hazardous Waste Removal.* Louisiana State University, Baton Rouge, LA, 62-76.
- Foght, J. M., and Westlake, D. W. S. (1984). "Biodegradation of hydrocarbons in freshwater." *Proceedings of the symposium on oil pollution in freshwater.* Edmonton, Alberta, Canada, 217-230.
- Goldsmith, C. D., Jr., and Balderson, R. K. (1988). "Biodegradation and growth kinetics of enrichment isolates on benzene, toluene, and xylene," *Water Sci. Tech.* 20(11/12), 505-507.
- Hambrick, G. H., III, Delaune, R. D., and Patrick, W. H., Jr. (1980). "Effect of estuarine sediment pH and oxidation-reduction potential on microbial hydrocarbon degradation," *Appl. Environ. Microbiol.* 40(2), 365-369.
- HNU Systems, Inc. (1992). "Portable hazardous waste analyzer," Manual of Operation, Newton, MA.
- Lang, S., and Wagner, F. (1987). "Structure and properties of biosurfactants." *Biosurfactants and biotechnology.* Marcel Dekker, Inc., New York.
- Marks, R. E., Field, S. D., Wajtanowicz, A. K., and Britenbeck, G. A. (1992). "Biological treatment of petrochemical wastes for removal of hazardous polynuclear aromatic hydrocarbon constituents," *Water Sci. Tech.* 25(3), 213-220.
- Mikelcic, J. R., and Luthy, R. G. (1988). "Microbial degradation of acenaphthene and naphthalene under denitrifying conditions in soil-water systems," *Appl. Environ. Microbiol.* 54(5), 1188-1198.
- Oberbremer, A., and Muller-Hurtig, R. (1989). "Aerobic stepwise hydrocarbon degradation and formation of biosurfactants by an original soil population in a stirred reactor," *Appl. Microbiol. Biotechnol.* 31, 582-586.

- Paris, D. N., Wolfe, N. L., and Steen, W. C. (1982). "Structure-activity relationships in microbial transformation of phenols," *Appl. Environ. Microbiol.* 44(1), 153-158.
- Park, K. S., Sims, R. C., and Dupont, R. R. (1990). "Transformation of PAHs in soil systems," *Jour. Environ. Engr.* 116(3), 632-640.
- Payne, J. R., and Phillips, C. R. (1985). "Photochemistry of petroleum in water," *Environ. Sci. Tech.* 19(7), 569-579.
- Perry, J. J. (1984). "Microbial metabolism of cyclic alkanes." *Petroleum Microbiology*. McMillan, New York.
- Ross, D. (1991). "Slurry-phase bioremediation: Case studies and cost comparisons," *Remediation* 1(1), 61-74.
- Sims, J. L., Sims, R. C., and Mathews, J. E. (1989). "Bioremediation of contaminated surface soils," EPA/600/9-89/073, Robert S. Kerr Environmental Research Laboratory, USEPA Office of Research and Development, Ada, OK.
- Stroo, H. F. (1990). "Biological treatment of petroleum sludges in liquid/solids contact reactors," *Environ. Waste Manag.* 3, 9-12.
- Stroo, H. F., Laakso, G. L., Owen, E. C., Bourquin, A. W., and Anderson, R. S. (1988). "Bioremediation of soil and water from a pesticide-contaminated site." *Proceeding Hazmacon 88*. Anaheim, CA, 734-742.
- Subba-Rao, R. V., and Alexander, M. (1982). "Effect of sorption on mineralization of low concentration of aromatic compounds in lake water samples," *Appl. Environ. Microbiol.* 44(3), 659-668.
- Thomas, J. M., Gordy, V. R., Fiorenza, S., and Ward, C. H. (1990). "Biodegradation of BTEX in subsurface materials contaminated with gasoline: Grange, Indiana," *Water Sci. Tech.* 22(6), 53-62.
- U.S. Environmental Protection Agency. (1979). "Methods for chemical analysis of water and wastes," EPA 600/4-79-020 (Revised 1983), Environmental Monitoring and Support Laboratory, Cincinnati, OH.
- _____. (1982). "Design manual—Dewatering municipal wastewater sludges," Center for Environmental Research Information, Cincinnati, OH.
- _____. (1986). "Test methods for evaluating solid waste," SW-846, 3rd ed., Office of Solid Waste and Emergency Response, Washington, DC.
- _____. (1990). "Slurry biodegradation," Engineering Bulletin EPA/540/2-90/016, USEPA Office of Research and Development, Cincinnati, OH.

U.S. Environmental Protection Agency. (1991). "Sampling and analysis plan for a bench-scale bioslurry test of soil from the Ninth Avenue Dump Superfund site, U.S. Army Engineer Waterways Experiment Station, Vicksburg, MS," USEPA, Washington, DC.

Versar, Inc. (1992). "Onsite engineering report for the treatment of soil from the Ninth Avenue site using pilot-scale bioslurry technology, U.S. Army Engineer Waterways Experiment Station, Vicksburg, MS," Springfield, VA.

Appendix A

Design Calculations

Calculations for reactor sizing:

given

Soil slurry = 40 percent = 0.4

Soil porosity = 0.4

γ_w = unit weight of water = 62.4 lb/cu ft

G_s = soil specific gravity = 2.5

Determine the weight of soil per cubic foot of reactor volume

$$S_s = \text{percent slurry} = \frac{W_s}{W_s + W_w} = 0.4 \quad (\text{A1})$$

where

W_s = weight of soil solids

W_w = weight of water

Equation A1 can be expressed in terms of volumes of solids V_s and water V_w

$$W_s = G_s V_s \gamma_w \quad (\text{A2})$$

$$W_w = V_w \gamma_w = \gamma_w (1 - V_s) \quad (\text{A3})$$

since

$$V_s + V_w = 1 \text{ cu ft} \quad (\text{A4})$$

Substituting in Equation A1 yields

$$\frac{G_s V_s \gamma_w}{G_s V_s \gamma_w + \gamma_w (1 - V_s)} = 0.4 \quad (\text{A5})$$

Substituting the value of $G_s = 2.5$ and solving Equation A5,

$$2.5V_s = 2.5 \times 0.4V_s + 0.4 - 0.4V_s$$

or

$$V_s = 0.2105 \text{ cu ft}$$

$$V_w = 1 - V_s = 1 - 0.2105 = 0.7895 \text{ cu ft}$$

For a bioslurry reactor with a size of 300,000 gal and 15 percent freeboard, the working volume is

$$300,000 \text{ gal} \times 0.85/7.48 \text{ gal/cu ft} = 34,090 \text{ cu ft}$$

Volume of soil needed for 40 percent soil slurry

$$= 34,090 \times 0.2105$$

$$= 7,176 \text{ cu ft}$$

$$= 266 \text{ cu yd}$$

For treating a soil volume of 1,500 cu yd, use 250 cu yd of soil per reactor each time; for all other soil volumes, use 270 cu yd of soil in the bioslurry reactor.

For a 500,000-gal-capacity reactor with 15 percent freeboard, similar calculations yield a soil volume per batch of 450 cu yd.

Appendix B

Labor and Energy Requirements for the Options Considered

Table B1 Labor and Energy Requirements for Cascading Reactors with Centrifuge Dewatering Option					
Item	Soil Volume, cu yd				
	1,500	5,000	10,000	20,000	50,000
Labor Requirements, Man-hours					
Screen and mixing	20	45	45	90	180
Bioslurry reactors	240	600	1,000	2,000	3,000
Nutrient feed	40	90	90	180	360
Centrifuge dewatering ¹	300	900	900	1,800	4,000
Miscellaneous	100	100	200	430	860
Total	700	1,735	2,235	4,500	8,400
Energy Requirements					
Screen and mixing, hp	75	75	150	300	500
Bioslurry reactors, hp	375	375	750	750	1,260
Nutrient feed, hp	5	5	5	10	15
Transfer pump, etc., hp	80	80	130	150	200
Total hp	535	535	1,035	1,210	1,975
Total kW-hr	399	399	772	902	1,473
kW-hr for operation time	1,149,500	2,873,600	5,559,200	12,960,000	228,288,300
kW-hr for centrifuge and building ¹	123,000	310,000	620,000	356,200	550,000
Total	1,272,500	3,183,600	6,179,200	13,316,200	28,838,300
¹ USEPA (1982).					

**Table B2
Labor and Energy Requirements for Single Reactor with Sand
Drying Bed Option**

Item	Soil Volume, cu yd				
	1,500	5,000	10,000	20,000	50,000
Labor Requirements, Man-hours					
Screen and mixing	60	150	300	170	580
Bioslurry reactors	560	1,600	3,200	3,700	9,800
Nutrient feed	120	300	600	330	1,170
Sand drying bed ¹	540,300	1,790	3,580	7,500	19,600
Miscellaneous	120	160	220	400	800
Total	1,400	1,400	7,900	13,200	34,550
Energy Requirements					
Screen and mixing, hp	75	75	75	150	200
Bioslurry reactors, hp	125	125	125	250	420
Nutrient feed, hp	5	5	5	10	15
Transfer pump, etc., hp	80	80	80	150	200
Total hp	285	285	285	560	835
Total kW-hr	213	213	213	418	623
kW-hr for operation time	1,428,700	4,396,320	8,690,400	11,028,870	38,869,600
Diesel oil for sand drying beds, gal	1,900	6,580	13,160	24,000	41,300
¹ USEPA (1982).					

REPORT DOCUMENTATION PAGE

Form Approved
OMB No. 0704-0188

Public reporting burden for this collection of information is estimated to average 1 hour per response, including the time for reviewing instructions, searching existing data sources, gathering and maintaining the data needed, and completing and reviewing the collection of information. Send comments regarding this burden estimate or any other aspect of this collection of information, including suggestions for reducing this burden, to Washington Headquarters Services, Directorate for Information Operations and Reports, 1215 Jefferson Davis Highway, Suite 1204, Arlington, VA 22202-4302, and to the Office of Management and Budget, Paperwork Reduction Project (0704-0188), Washington, DC 20503.

1. AGENCY USE ONLY (Leave blank)	2. REPORT DATE October 1995	3. REPORT TYPE AND DATES COVERED Final report
---	---------------------------------------	---

4. TITLE AND SUBTITLE Bioremediation of Soils Contaminated with Petroleum Hydrocarbons Using Bioslurry Reactors	5. FUNDING NUMBERS
--	---------------------------

6. AUTHOR(S) Shankha K. Banerji, Mark E. Zappi, Cynthia L. Teeter, Douglas Gunnison, M. John Cullinane, Robert T. Morgan	
---	--

7. PERFORMING ORGANIZATION NAME(S) AND ADDRESS(ES) University of Missouri, Department of Civil Engineering Columbia, MO 65211; U.S. Army Engineer Waterways Experiment Station, 3909 Halls Ferry Road, Vicksburg, MS 39180-6199	8. PERFORMING ORGANIZATION REPORT NUMBER Miscellaneous Paper IRRP-95-2
---	---

9. SPONSORING / MONITORING AGENCY NAME(S) AND ADDRESS(ES) U.S. Army Corps of Engineers, Washington, DC 20314-1000	10. SPONSORING / MONITORING AGENCY REPORT NUMBER
---	---

11. SUPPLEMENTARY NOTES

Available from National Technical Information Service, 5285 Port Royal Road, Springfield, VA 22161.

12a. DISTRIBUTION / AVAILABILITY STATEMENT Approved for public release; distribution is unlimited.	12b. DISTRIBUTION CODE
--	-------------------------------

13. ABSTRACT (Maximum 200 words)

The Department of Defense has over 12,000 sites contaminated from military activities. Many sites contain petroleum contamination and residues from fueling, maintenance, and training activities. Use of bioslurry reactors may be an appropriate means for decontaminating these soils.

This report presents data from two bench-scale and two pilot-scale studies that evaluated the suitability of the bioslurry process to bioremediate soils contaminated by petroleum hydrocarbons. Soils from two contaminated sites were studied. The first soil contained polycyclic aromatic hydrocarbons (PAHs), BTEX (benzene, toluene, ethylbenzene, and xylene) compounds, ketones, and chlorinated ethanes; the second soil contained gasoline and associated compounds. Conceptual designs and costs of bioslurry processes for field applications are also presented.

Bench-scale studies were performed in 5-L batch reactors, equipped with aeration and mixing equipment. Various nutrient amendments, surfactants, and selected microbial consortia were evaluated during the bench-scale studies. Several reactors were also operated using only native microbes. Pilot-scale testing was accomplished using 60-L EIMCO reactors, also equipped with aeration and mixing systems. Off-gases were recirculated, with CO₂ removed in a scrubber and additional O₂ added as required.

(Continued)

14. SUBJECT TERMS BTEX Bioslurry Biotreatment	 Polycyclic aromatic hydrocarbons (PAHs) Total petroleum hydrocarbons (TPHs)		15. NUMBER OF PAGES 75
			16. PRICE CODE

17. SECURITY CLASSIFICATION OF REPORT UNCLASSIFIED	18. SECURITY CLASSIFICATION OF THIS PAGE UNCLASSIFIED	19. SECURITY CLASSIFICATION OF ABSTRACT	20. LIMITATION OF ABSTRACT
--	---	--	-----------------------------------

13. (Concluded).

The results from both bench- and pilot-scale testing indicated that native microbial species in contaminated soils can biodegrade total petroleum hydrocarbons, volatile organics (BTEX), and PAH compounds to low residual values at reasonable retention times. Removal of PAHs ranged from 47 to 97 percent, TPH removal from 68 to 83 percent, and volatile compounds removal from 61 to 99 percent. Vapor recirculation was required to prevent loss of volatile components from the reactor. Addition of surfactants was not found to be beneficial in this study. The estimated cost for treating greater than 20,000 cu yd of contaminated soil ranged from \$150 to \$200/cu yd, depending on the type of system used.

Destroy this report when no longer needed. Do not return it to the originator.