

## BODY X-RAY ANTHROPOMETRY MANUAL

DOROTHY A. FRANCIS

Technical Report

June 1995

NAVAL BIODYNAMICS LABORATORY  
Box 29407  
New Orleans, LA 70189-0407



19960215 059

Approved for public release; distribution is unlimited.

Prepared for

Naval Medical Research and Development Command  
Bethesda, MD 20889-5044

DTIC QUALITY INSPECTED 1

Approved by

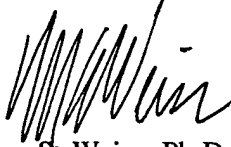

Marc S. Weiss, Ph.D.  
Chairman, Scientific Review Committee

Released by

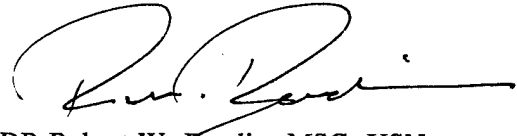

CDR Robert W. Rendin, MSC, USN  
Commanding Officer

Naval Biodynamics Laboratory  
P. O. Box 29407  
New Orleans, LA 70189-0407

Approved for public release; distribution is unlimited. Reproduction in whole or part is permitted for any purpose of the United States Government.

The interpretations and opinions in this work are the author's and do not necessarily reflect the policy and views of the Navy or other government agencies.

In the interest of precision, trade names of products are cited. These citations do not constitute endorsements of the products.

# REPORT DOCUMENTATION PAGE

*Form Approved*  
*OMB No. 0704-0188*

Public reporting burden for this collection of information is estimated to average 1 hour per response, including the time for reviewing instructions, searching existing data sources, gathering and maintaining the data needed, and completing and reviewing the collection of information. Send comments regarding this burden estimate or any other aspect of this collection of information, including suggestions for reducing this burden, to Washington Headquarters Services, Directorate for Information Operations and Reports, 1215 Jefferson Davis Highway, Suite 1204 Arlington, VA 22202-4302, and to the Office of Management and Budget, Paperwork Reduction Project (0704-0188), Washington, DC 20503.

<b>1. AGENCY USE ONLY (Leave Blank)</b>	<b>2. REPORT DATE</b> June 1995	<b>3. REPORT TYPE AND DATES COVERED</b> Interim	
<b>4. TITLE AND SUBTITLE</b> Body X-Ray Anthropometry Manual		<b>5. FUNDING NUMBERS</b>  63216 M0097.001	
<b>6. AUTHOR(S)</b>  Dorothy A. Francis			
<b>7. PERFORMING ORGANIZATION NAME(S) AND ADDRESS(ES)</b>  Naval Biodynamics Laboratory P. O. Box 29407 New Orleans LA 70189-0407		<b>8. PERFORMING ORGANIZATION REPORT NUMBER</b>  NBDL-94R003	
<b>9. SPONSORING/MONITORING AGENCY NAME(S) AND ADDRESS(ES)</b> Naval Medical Research and Development Command National Naval Medical Center Building 1, Tower 12 Bethesda, MD 20889-5044		<b>10. SPONSORING/MONITORING AGENCY REPORT NUMBER</b>	
<b>11. SUPPLEMENTARY NOTES</b>			
<b>12a. DISTRIBUTION/AVAILABILITY STATEMENT</b>  Approved for public release; distribution is unlimited.		<b>12b. DISTRIBUTION CODE</b>	
<b>13. ABSTRACT (Maximum 200 words)</b>  This publication provides documentation of body (neck) x-ray anthropometry data acquisition and analysis. It also documents the anthropometry photogrammetric program used on an IBM-compatible 486 personal computer at the Naval Biodynamics Laboratory in New Orleans, LA.			
<b>14. SUBJECT TERMS</b>  Neck anthropometry; x-ray anthropometry; transformation; computer software; GIANT.			<b>15. NUMBER OF PAGES</b> 30
			<b>16. PRICE CODE</b>
<b>17. SECURITY CLASSIFICATION OF REPORT</b> Unclassified	<b>18. SECURITY CLASSIFICATION OF THIS PAGE</b> Unclassified	<b>19. SECURITY CLASSIFICATION OF ABSTRACT</b> Unclassified	<b>20. LIMITATION OF ABSTRACT</b>

## TABLE OF CONTENTS

Introduction .....	1
Background .....	1
Body X-Ray Photogrammetry .....	2
The Chair .....	2
The Subject .....	3
The X-Rays .....	4
Specifications for Body Anthropometry X-Rays .....	5
X-Ray Stereopairs .....	5
Definition .....	5
Procedure .....	5
Preliminary X-Ray Requirements .....	5
Primary Components and Requirements .....	5
Chair .....	5
Film Carrier Frame .....	8
Neck Mount .....	8
Sternum .....	8
Subject .....	8
X-ray Machine .....	8
Procedure for Taking Body Anthropometry X-Rays .....	10
Setup Requirements .....	10
Taking the X-Rays .....	12
Data Acquisition and Analysis .....	14
Acquisition of Stereo Anthropometric Data .....	14
Marking the X-Rays .....	14
Description of Photogrammetric Software and Digitizer .....	15
Processing Body (Neck) Anthropometry .....	16
References .....	26

## NAVAL BIODYNAMICS LABORATORY TECHNICAL REPORT

---

### ACKNOWLEDGEMENTS

No one ever writes a report alone, regardless of what the title page may assert. It is obvious that this manual is a reflection of the expertise of many knowledgeable individuals. The author acknowledges the contributions of the many other members of the Naval Biodynamics Laboratory (NBDL) and GPA Associates for the development of these procedures and for their valuable collaboration on this manual.

It is not possible in syllable and sentence for me to express my appreciation for the many individuals who have contributed to this work. Everyone at NBDL played some part in the final product, a documented and established Body X-ray Anthropometry procedure. Thanks to all. Special acknowledgement to several former and present colleagues: Ms. Patricia Kilgore and Mr. Gary Jupiter of the Data Systems Division, Mr. Nick Price and Dr. Gilbert of the Biomedical Department, Mr. Gil Willems, Mr. Roger Black and Mr. Art Prell of the Technology Department, Dr. Salvatore Guccione, the Principal Investigator, Mr. Cliff Mugnier of GPA Associates and the Human Research Volunteers, who truly made all this possible.

These acknowledgements would be incomplete without thanking Ms. Roseann LaBostrie for typing the manuscript and Mr. Art Prell again for the photographs and the printing.

# BODY X-RAY ANTHROPOMETRY MANUAL

## Introduction

Body anthropometry as practiced at the Naval Biodynamics Laboratory (NAVBIODYNLAB) in New Orleans involves the establishment of a coordinate system fixed within the human body at the first thoracic vertebral body (T-1). The origin of this coordinate system is defined as the anterior superior corner, and the negative X-axis runs from the origin through the mid-point of the line between the upper and lower posterior spinous process. The Y-axis is perpendicular to the X-axis and lies in the plane determined by the X-axis and the line connecting the two articular facets. The Z-axis (up) is the cross product of the X-axis and the Y-axis (Fig. 1).

## Background

The original body anthropometry method used at NAVBIODYNLAB involved two simultaneous x-rays

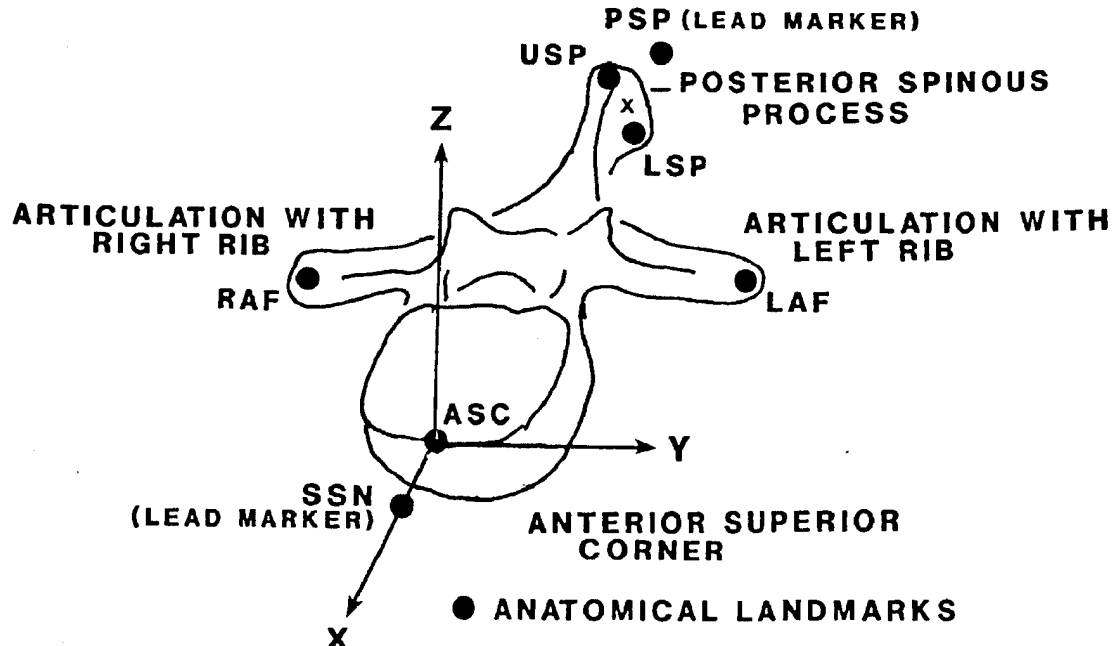

Figure 1  
The T-1 Anatomical Coordinate System.

of the subject, one taken laterally and the other anterior-posterior (A/P). So much of the body had to be penetrated by the lateral x-ray that none of the anatomical landmarks were visible in this view. An indirect method involving some geometric assumptions was devised to circumvent the lack of adequate data. The A/P and lateral views were used to simplify the mathematics and not out of necessity.

To enhance the accuracy of the body x-ray anthropometry, a new method using photogrammetry and stereo x-rays was proposed. After some trials and errors, a set of two stereo x-ray pairs was chosen, with each pair approximately  $45^\circ$  on opposite sides of the A/P direction. There are several reasons for this configuration: (1) X-rays taken at  $45^\circ$  to the A/P direction do not have to penetrate as much bone mass as lateral x-rays. (2) Straight A/P x-rays did not pass through enough bone. (3) A point imaged on only two x-ray filmplanes can be located in three dimensions, but no indication of the error in that location can be given. The same point imaged on four x-ray film planes has additional degrees of freedom for estimating the error in the 3-D location. (4) The correct identification of a specific point of interest is enhanced by the stereo viewing process.

### Body X-Ray Photogrammetry

The desire to duplicate the physical conditions occurring during an impact acceleration test prompted a more careful look at all the steps involved in the anthropometric process.

**The Chair.** If the subject slumps in the chair (Fig. 2) during the x-rays, conditions can be altered to the point that the resulting transformations from body to instrument coordinate systems are not valid for the actual acceleration tests. Furthermore, it was found that many subjects were unable to maintain identical posture between the two views of a stereo pair, particularly when several BB's were placed on the subject's neck.

A new chair was designed to simulate the chair on the accelerator, including the ability to raise or lower the subject to a given vertical position independent of his actual height. The chair was made transparent to x-rays as were all straps, mounts, and other required materials. The chair can be rolled into the first position after the subject is strapped in; rolled from there to the next position, and then rotated for the last two positions — all without moving the subject appreciably and thereby possibly invalidating the results. Guide rails (Figs. 3, 4) are placed on the floor to facilitate proper location of the chair as it is moved. Several BB's are imbedded in the chair in regions near the subject's shoulders and along both sides of the neck. These "pass

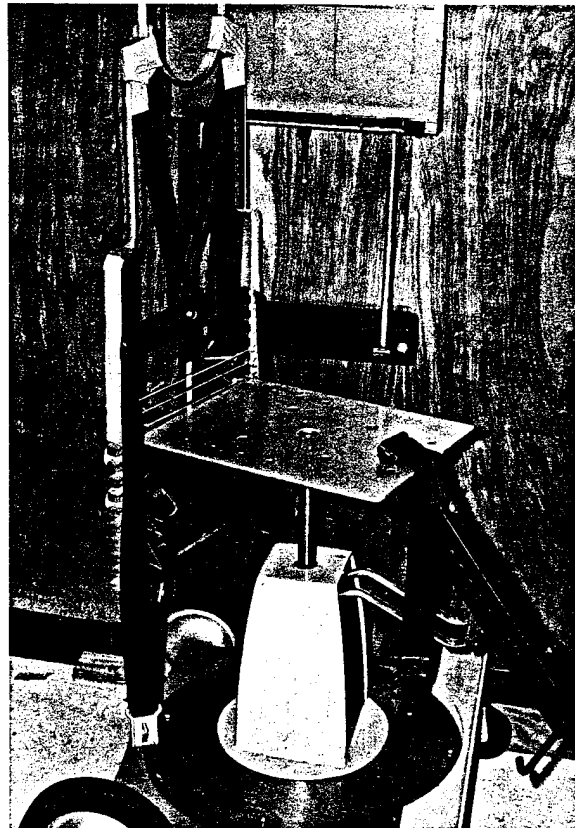

Figure 2  
X-Ray Chair

## *Body X-Ray Anthropometry Manual*

points" can be seen on all four of the x-rays and are digitized along with the desired points on the subject. They lend additional degrees of freedom to the photogrammetric solution, substantially improving its accuracy.

**The Subject.** The subject actively participates by helping to assure that the position required for the x-rays is achieved. A single BB is taped to the super sternal notch and aids in finding the correct vertebra in the stereo x-ray pairs. Another BB is positioned over the T-1 vertebra in a special mount fitted individually to each subject. This mount is strapped onto the subject and supports the T-1 instrumentation package and photo targets. Special effort must be made to assure that this mount is leveled and is in the same position as it will be for acceleration runs.

Chair seat-back heights will be specified for each subject. The x-rays should be taken at this seat-back height. If x-rays are made at a different seat-back height than specified, that fact should be noted and the actual seat-back height should be entered in the appropriate record(s).

The subject is then secured in the chair with straps around the waist, shoulder, and groin areas. Care is taken to insure the waist and shoulder straps are horizontal and that the shoulder strap is under the T-1 mount strap. The knees are also restrained by a strap. Lead goggles and a protective lead lap apron are placed on the subject before x-rays are taken. Care is taken to insure the lap apron completely covers

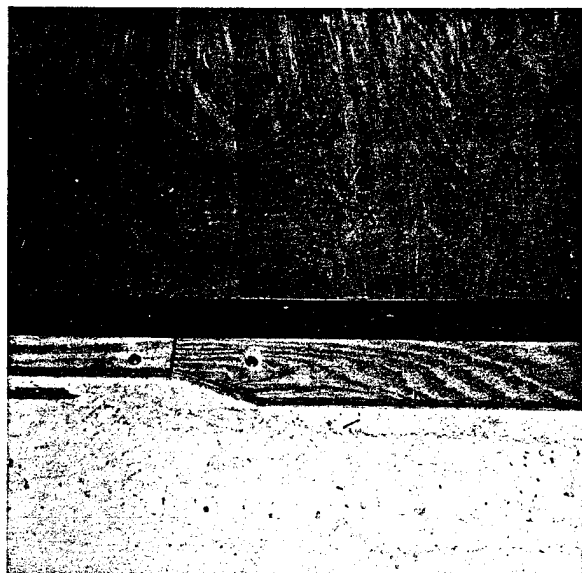

Figure 3  
Guide Rails for X-ray Chair

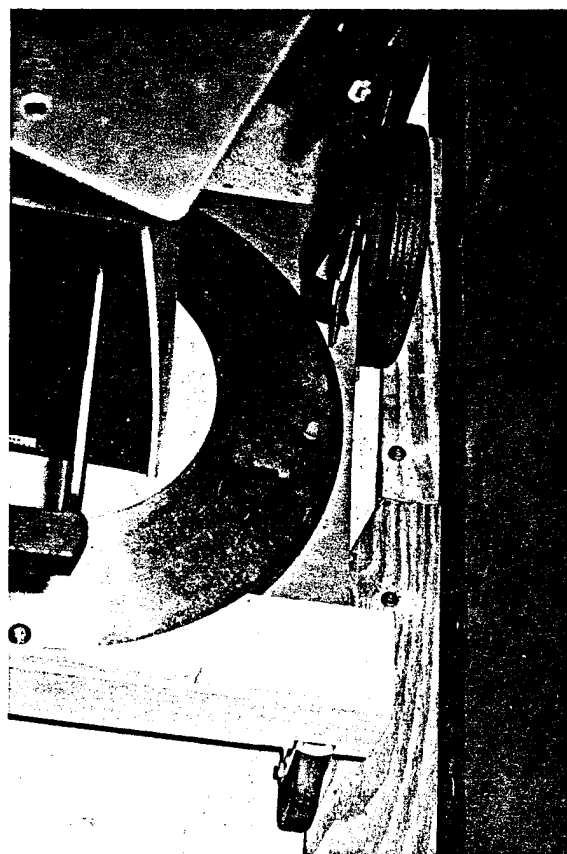

Figure 4  
X-ray Chair Positioned in Guide Rails

## NAVAL BIODYNAMICS LABORATORY TECHNICAL REPORT

the reproductive organs of female subjects (Figs. 5, 6).

**The X-Rays.** The four x-rays are taken. Two with the left shoulder to the plate and two with the right shoulder to the plate (i.e., the subject and chair are rotated about 45° in each direction). For each exposure, the subject is wheeled as far as possible to the left (and then to the right) — a total distance of only about 10 cm (4 in) or so — while still assuring that the sternum BB and those on the T-1 instrumentation BB target package, especially the extreme cube, are in the picture.

The two sets of stereopairs (four x-rays) are as follows:

Set 1: Left shoulder to plate (Figs. 7 - 10):

Left eye view, left shoulder to plate (Figs. 7, 9)

Right eye view, left shoulder to plate (Figs. 8, 10)

Set 2: Right shoulder to plate (Figs. 11 - 14):

Left eye view, right shoulder to plate (Figs. 11, 13)

Right eye view, right shoulder to plate (Figs. 12, 14)

When the left shoulder is to the plate, the stereo pair positions are labelled as follows: The first, as far right as possible, is called "left shoulder, left eye"; the second one, shifted slightly to the left, is called "left shoulder, right eye." When the right shoulder is to the plate, the stereo pair positions are



Figure 5  
Subject Strapped in Chair



Figure 6  
Subject Ready for X-Ray

labelled as follows: The first, as far left as possible, is called "right shoulder, right eye"; the second one, shifted slightly to the right, is called "right shoulder, left eye."

### **Specifications for Body Anthropometry X-Rays**

The first stage of the body x-ray anthropometry data acquisition process provides two stereo x-ray pairs. As previously explained, each pair containing an x-ray taken approximately 45° to the left and another approximately 45° to the right of the A/P view for each subject. This was formerly referred to as neck anthropometry. The phrase *body anthropometry* is used now because we are looking at more than the neck in this new procedure.

#### **X-Ray Stereopairs.**

**Definition.** A stereoscopic pair or stereopair consists of two photographs of the same area taken from different camera stations so as to afford stereoscopic vision. Stereoscopic vision is the particular application of binocular vision that enables the observer to obtain the impression of depth, usually by means of two different perspectives of an object (as two photographs taken from different camera stations). For body anthropometric x-rays, the camera remains fixed while the position of the chair with subject is varied.

**Procedure.** The subject, with neck mount in place, is strapped in a special chair. The chair is then rolled into the first position. From there it is rolled to the next position (moved right approximately 4 in), and then rotated for the last two positions, all while the subject remains strapped in position and unable to move appreciably. Four x-rays are taken (see "The X-Rays," above).

**Preliminary X-Ray Requirements.** There is no sequence of events for these requirements. Each is separate and independent.

1. Subject must have the complete T1 - T2 mount (properly fitted and approved for use in experiments). Mount must have BB implanted (Fig. 15).
2. Seat heights must be measured in advance.
3. Subject's x-rays with neck extended should be ready for viewing. These are the pre-qualifying x-rays that were taken during recruiting.
4. Subject has been fitted for chest harness.
5. Photogrammetric neck mount radiographic targets holder has been surveyed and approved for use in the body x-ray anthropometry data acquisition process (Figs. 16, 17).

#### **Primary Components and Requirements.**

**Chair.** A chair was designed to simulate the chair on the accelerator, with the ability to raise or lower the subject to a given vertical position independent of his actual height (Fig. 5). Chair seat-back heights will be specified for each subject. X-rays should be taken at this seat-back height. As previously stated, if x-rays are taken using a different seat-back height than specified, the fact that a change has been made and the seat-back height used should be entered in the appropriate records. (See Fig. 18 for chair seat-back heights.)

The chair also directly participates in the x-ray anthropometry process. Several BB's are imbedded in the chair in regions near the shoulder of the subject and along both sides of his neck. At least one set of these BB's should be visible on each x-ray (Fig. 19).



Figure 7  
Left Shoulder, Left Eye

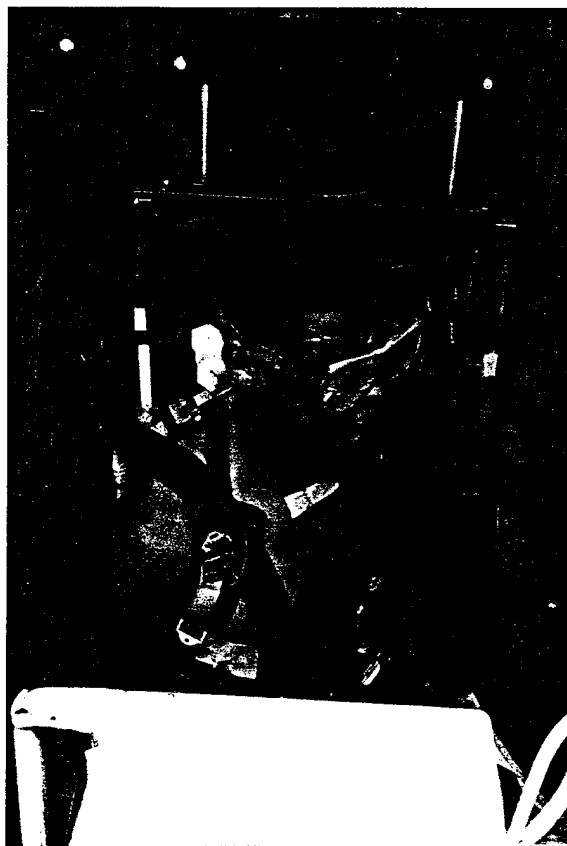

Figure 8  
Left Shoulder, Right Eye



Figure 9  
Left Shoulder,  
Left Eye X-Ray



Figure 10  
Left Shoulder,  
Right Eye X-Ray



Figure 11  
Right Shoulder, Left Eye



Figure 12  
Right Shoulder, Right Eye



Figure 13  
Right Shoulder, Left Eye X-Ray



Figure 14  
Right Shoulder, Right Eye X-Ray

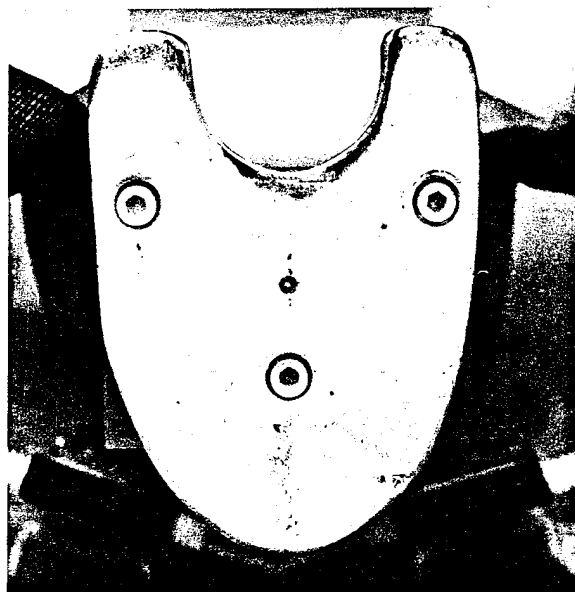

Figure 15  
T1/T2 Mount With BB Implanted

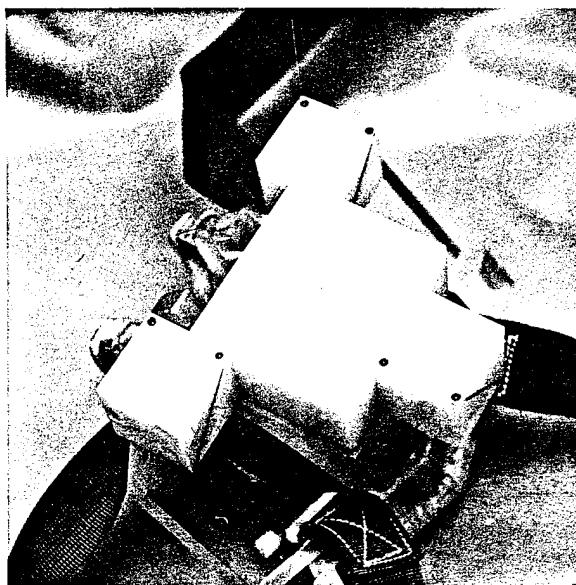

Figure 16  
Neck Mount Radiographic  
Targets Holder

**Film Carrier Frame.** BB's have been placed along the edges of the acrylic plate in the frame holding the film carrier (Fig. 20). The carrier frame was structurally modified to prevent the film from being inverted in the film carrier frame. Most of the BB's on the plate edges *must* be visible on all the x-rays. These points will be used in the determination of corner fiducials, which are a series of reference points necessary to run NGIANT.<sup>1</sup>

**Neck Mount.** Special effort must be made to assure that the mount positioned over the T-1 vertebra is in the same position and leveled as it will be for the acceleration runs (Fig. 21). The mount must have a BB implanted in the center; this is done during manufacturing of the custom mount (Fig. 15).

**Sternum.** A single BB is taped to the subject's suprasternal notch. This must be visible on each x-ray.

**Subject.** If the subject slumps in the chair during the x-ray, conditions can be altered so that the resulting transformations from the body coordinate system to the instrument coordinate system are not valid for the actual acceleration runs. Furthermore, stereo viewing may be rendered impossible. Therefore, the subject must sit up straight in the chair and be as still as possible while a pair of x-rays is being taken. Every effort must be made to produce identical x-ray pairs.

**X-ray Machine.** The x-ray machine must also be positioned fairly accurately and consistently. *The collimator must be 33 in from the tube to the grid.* Any change must be approved by the Command photogrammetrist before x-rays are taken (Fig. 22).

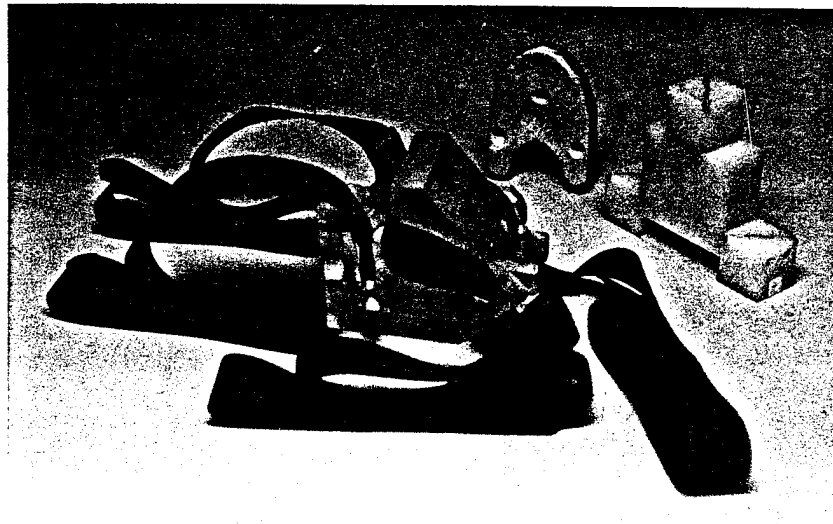

Figure 17  
Neck Mount Separated: Lectern, T1/T2 Mount,  
Radiographic Targets Holder

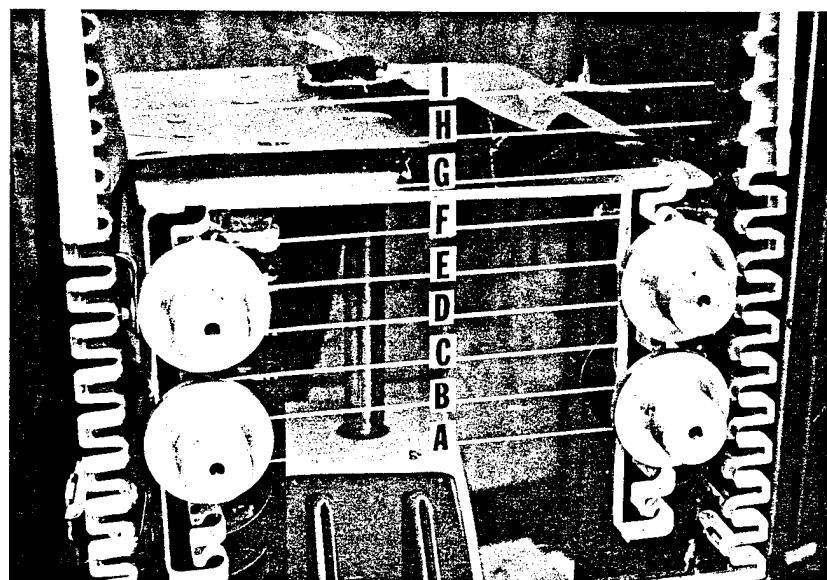

Figure 18  
X-Ray Chair Seat-Back Heights

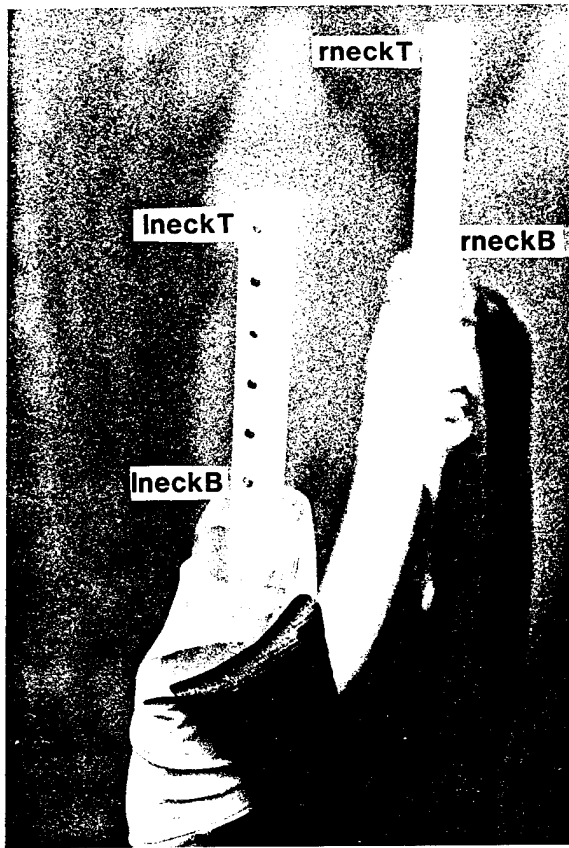

Figure 19  
X-Ray Chair Neck Markers

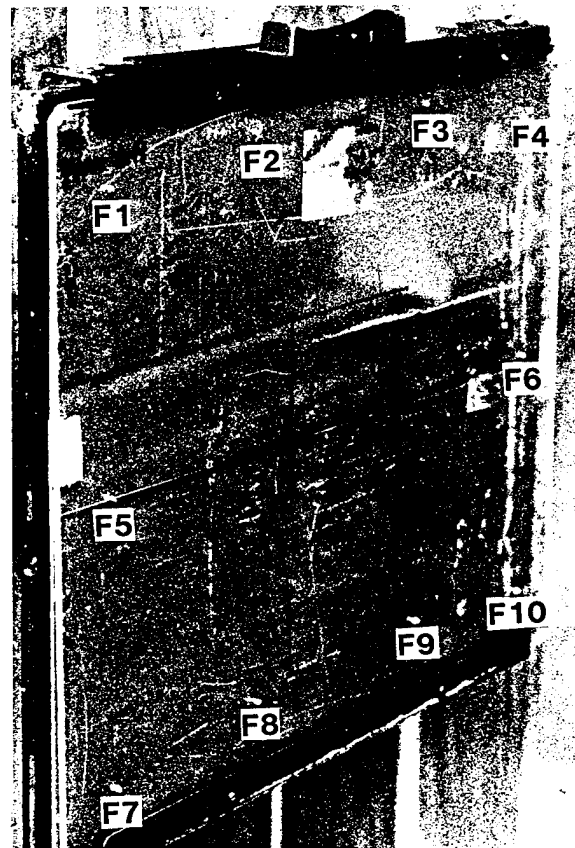

Figure 20  
Film Carrier Frame

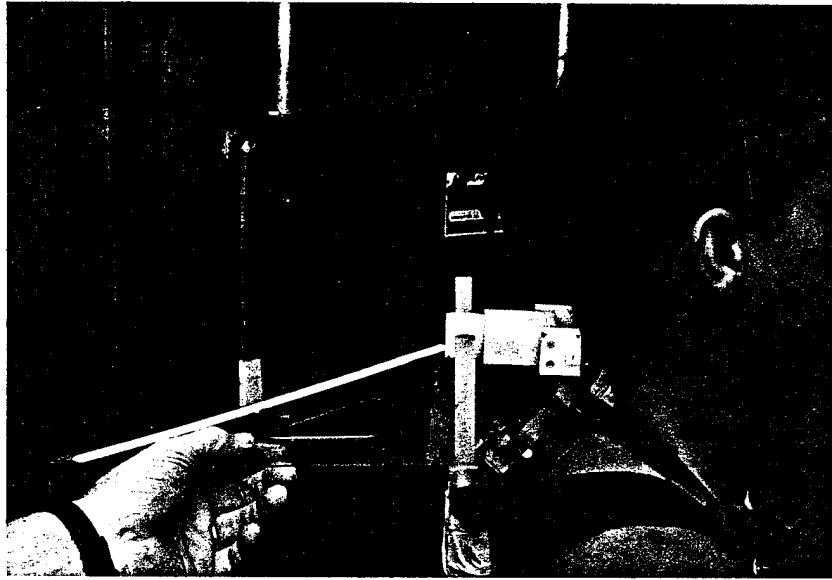

Figure 21  
Neck Mount and Target Holder Properly Positioned

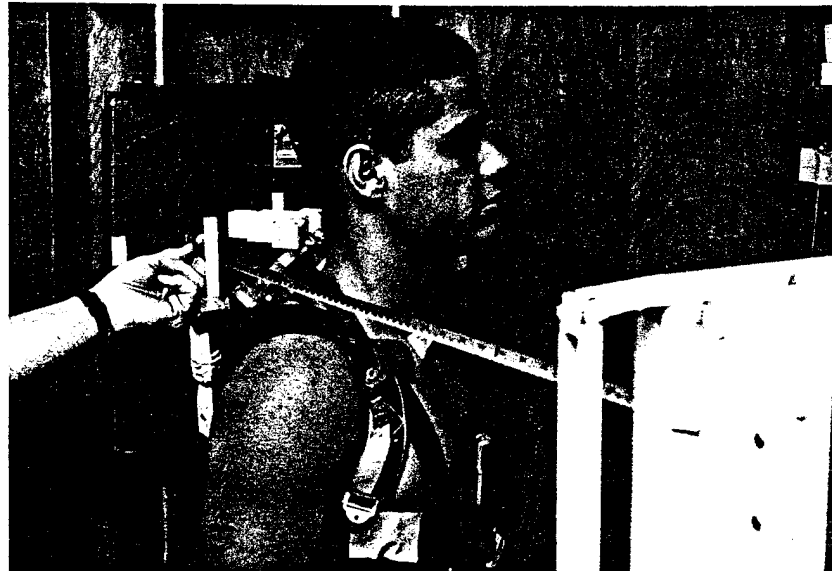

Figure 22  
Collimator 33 Inches From Tube to Grid

## Procedure for Taking Body Anthropometry X-Rays

**Setup Requirements.** The following items are required at the x-ray site:

- (1) X-rays of subjects with neck extended (cervical x-rays)
- (2) X-ray Chair (weight: 145 lb)
- (3) Subject(s)
- (4) T1/T2 Fiberglass mount with BB implanted for each subject
- (5) Plexiglass lectern for T1/T2 mount with nylon straps
- (6) Neck mount radiographic target array
- (7) 6-32 nylon screws and screwdriver
- (8) Chest harness for each subject
- (9) Number 6 lead shot BB for sternum
- (10) Chair-seat height for each subject (Technology Department's subject log book)
- (11) Duct tape and medical tape
  
- (12) Sport bras for female subjects (should be wearing them)
- (13) Paper pants
- (14) Lead goggles
- (15) Lead lap apron
- (16) Light table or x-ray film view box
- (17) Stereoscope and stand
- (18) Aluminum podium for stereoscope stand
- (19) Custom NAVBIODYNLAB x-ray film carrier frame with cassette holder, grid, and fiducial calibration plate attached
- (20) Floor guides (chair distance/parallel control base) and locking block (wheel locking device) for x-ray chair
- (21) 10-in, 45° engineering triangle
- (22) Level small enough to measure T1/T2 mount

### Taking the X-Rays.

- (1) Position the contractor's cassette holder at the bottom of the cassette rack.
- (2) Mount the custom NAVBIODYNLAB x-ray cassette holder on the rack directly above the contractor's cassette holder.
- (3) Load the custom NAVBIODYNLAB x-ray film carrier with 14-in × 17-in Cronex-4 DuPont Cassettes or another standard x-ray cassette.
- (4) Place film in stationary grid. Place cassette, with identification marker, on the right bottom.
- (5) Establish the center line height of the NAVBIODYNLAB cassette holder by setting the contractor's x-ray bucky height at 22 in and using the crosshairs projecting to the center of the holder.
- (6) Adjust collimator to proper size.
- (7) Take an x-ray of the neck of the empty x-ray chair to check the exposure quality of the x-ray.
- (8) Develop the x-ray. The neck BB's should be visible on the x-ray without using a special light source. If this is not the case, the x-ray is too dark.
- (9) Adjust the x-ray machine controls and repeat steps 7 and 8 until the proper exposure quality is achieved.

## *Body X-Ray Anthropometry Manual*

---

- (10) Perform steps 7 through 9 only once for a series of x-rays.
  - (11) While steps 7 through 9 are being performed, the subject should be prepared as follows:
    - (a) Checked for proper attire
    - (b) Location of T-1 marked
    - (c) Proper size and configuration of chest harness ensured
    - (d) Chest harness put on and tightened
    - (e) T1/T2 mount assembly strapped on
    - (f) Number 6 lead BB taped to subject's sternum
  - (12) Set chair seating height to subject's chair-seat height.
  - (13) Position subject in the chair. Rump should be firmly against the back of the seat.
  - (14) Check for proper foot rest height. Proper foot rest height is achieved when the thighs are level.
  - (15) Place shoulder strap under the T-1 mount strap.
  - (16) Restrain knees with a strap.
  - (17) Tighten lap restraints. Lap belt buckle/crotch strap should be tight and centered. The tension should be equal on both sides.
  - (18) Adjust T-1 mount assembly so that it is straight and leveled.
  - (19) Move the chair (with subject) into position. (Subject's right or left shoulder to the x-ray plate.) The chair should be parallel to the x-ray holder and wheels in the floor guides.
  - (20) Position the neck of the chair so that there is a 45° angle between the acrylic rods and the fiducial calibration plate.
  - (21) Lock front swivel wheels of the chair in place.
  - (22) Position subject, film, and central ray.
  - (23) Position the collimator 33 in from tube to grid. (*NOTE: Collimator must be 33 in from tube to grid. Any change must be approved by the Command photogrammetrist before x-rays are taken.*)
  - (24) Line up the center line of the collimator with the film grid center line by raising or lowering the chair and/or x-ray source and film grid.
  - (25) Set x-ray chair height by using the horizontal center line of the collimator. The crosshairs should intersect over the subject's T1/T2 area.
  - (26) Ensure that the chair height is such that the base of the skull will be visible on each x-ray.
  - (27) Set the x-ray machine controls to produce the best possible x-rays. The bones and BB's should be distinct and clearly recognizable. The radiographer will determine the proper machine settings.
  - (28) Place lead goggles on the subject's face.
  - (29) Place protective lead lap apron on subject. Completely cover the reproductive organs of the female subjects.
  - (30) Ensure T-1 mount is straight and leveled.
  - (31) Ensure sternum BB and those on the neck of the chair will be in the x-ray.
  - (32) Ensure collimator is positioned 33 in from tube to grid.
  - (33) Ensure acrylic plate with BB's on the edges is in the film carrier frame.
  - (34) Ensure BB's on acrylic plate are in the picture and all points of interest are within these BB's.
  - (35) Brief subject about movement during x-rays, requesting that he or she remain as still as possible.
- Whatever was done on the first x-rays must be done on the second pair.
- (36) Take the x-ray.
  - (37) Move the subject to the next position.
  - (38) Take the second x-ray.
  - (39) Develop the x-rays.
  - (40) Check x-rays for stereopairs. View the pair of x-rays under a stereoscope. The anterior superior

## NAVAL BIODYNAMICS LABORATORY TECHNICAL REPORT

---

points of C6 - C7 must be visible and the impression of depth *must* be observed.

(41) Wait until x-rays are checked for stereopairs before moving the subject to the other shoulder-to-plate position.

(42) Repeat process until a stereopair is produced. A medical doctor will monitor the subjects and terminate the x-rays if necessary. Numbness of limbs, feeling faint, radiation exposure limits reached, etc., are possible reasons for termination. However, the process is usually successful the second time.

(43) Label the x-rays with the subject's number and put in an envelope.

(44) Change shoulder to plate position and repeat steps 22 - 43.

(45.) Repeat steps 11 through 44 for each subject.

## **Data Acquisition and Analysis**

**Acquisition of Stereo Anthropometric Data.** The x-rays are viewed through a mirror stereoscope, an instrument for viewing a stereopair of photographs. This device uses mirrors in addition to simple lenses so that a relatively large area of each pair of photographs is viewed<sup>2</sup> and positioned until they form a stereomodel. A stereomodel is a three-dimensional model formed by the visual overlapping of a stereopair of photographs.<sup>2</sup> Once a stereomodel is formed, the x-rays are secured in place. Then the stereoscope is used to locate the points defining the anatomical coordinate system (Fig. 1). These points are then marked for digitization (if necessary, with a doctor's assistance) on the x-rays with a marker (Fig. 23). Several BB's placed at known locations are also labelled and digitized.

### **Marking the X-Rays.**

(1) The following items are required:

- (a) An x-ray stereopair
- (b) A Lumocolor #313 waterproof permanent marker or some other type of fine point felt tip permanent marker
- (c) Several sheets of 8½-in × 11-in plastic transparency
- (d) Acetone or nail polish remover
- (e) A stereoscope
- (f) Plastic strip with a dot on one end
- (g) Light table or Altex Digitizer
- (h) Scotch tape
- (i) Paper towels

(2) Get the required items. These are usually readily available in the digitizing room. The mirror stereoscope is a very expensive and delicate tool. It is portable and folds to fit into a special carrying case. When not in use, the stereoscope and its four removable legs are secured in the carrying case, which stays in the digitizing room. To use the stereoscope, it must be unfolded and mounted on four legs, which screw into its base, or on the stereoscope stand, which stays in the digitizing room.

(3) Cover the areas to be marked (the anatomical coordinate system and all BB's on the mount) with a sheet of transparency and secure it in place with scotch tape. Most of the markings are to be done on the transparency, not directly on the x-ray. Erroneous marks may be erased with acetone or nail polish remover.

(4) Using the stereoscope, position the x-ray stereopair until they are properly orientated for stereoscopic viewing.<sup>3</sup> When the x-rays are in stereo, secure them in place with scotch tape.

(5) Mark one x-ray at a time. The bones of the anatomical coordinate system (Fig. 1) should be marked first because they must be marked in stereo. Mark the bones on one x-ray first. Then mark the bones on the second x-ray using the floating dot technique to ensure that the marks are in the same place on each x-ray. (A floating mark or dot is a mark seen as occupying a position in the three-dimensional space formed by the stereoscopic fusion of a pair of photographs and used as a reference mark in examining or measuring the stereoscopic model.<sup>4</sup> The floating dot technique requires using the dot on the plastic strip to mark the bones on the second x-ray by moving the dot until it appears to merge with the dot on the previously marked x-ray. You should see what appears to be a floating dot. When this condition occurs, the dots are in approximately the same location. Mark a dot on the second x-ray at this location.)

(6) Mark the other BB's that are distinctly defined without viewing the x-rays in stereo, such as the shoulders, the sternum, the spine BB, and the neck mount BB's.



Figure 23  
Marking the X-rays in Stereo

**Description of Photogrammetric Software and Digitizer.** The photogrammetric software package used at NAVBIODYNLAB is a customized version of GIANT™ (an acronym for General Integrated Analytical Triangulation).<sup>5</sup> GIANT™ will perform a simultaneous bundle adjustment of perspective imagery (photos, x-rays, etc.) by enforcing the collinearity condition.<sup>6</sup> PREP™ is the pre-processor for transforming comparator coordinates to a plate-centered coordinate system with various corrections for systematic errors. NPREP, a customized version of PREP™, developed by GPA Associates for NAVBIODYNLAB, automates the digitization process and creates the GIANT™ input image file. NPREP creates the image file for NGIANT for a particular subject using the human research volunteer (HRV) number. NGIANT will find all the necessary points in space and compute the locations of the specific body points by regression on the x, y, and z coordinates of the BB's or known locations. It then has all the information to calculate the transformation from anatomical to instrumentation coordinate systems.<sup>7</sup>

An ALTEK™ AC30 digitizer is used to digitize the x-rays (Fig. 24, 25). The user only needs to know how to operate the digitizer cursor, because all the necessary commands have been incorporated into NPREP. The cursor has a viewing site with a set of crosshairs and four push-button controls, and two warning lights (Fig. 26).

The center of the point to be digitized should be centered in the crosshairs on the cursor. The red light will come on when the cursor is out of the digitizing range. The white light comes on when data has been transmitted. The control buttons are defined as follows:

## *Body X-Ray Anthropometry Manual*

---

Yellow = missing  
Red = error-backup  
Green = fiducial or data point  
Blue = abort

The green button is used to enter data. If a point is missing (can't be seen on a particular photo or x-ray), press the yellow button. The red button is used for mistakes. If you input the wrong point(s), just push the red button until you back up to the correct point. The blue button is also used for mistakes. If data for the photo or x-ray being processed is erroneous, the complete data set may be aborted by pressing the blue button. All input is displayed on the screen. Data points will be labelled and x and y coordinates printed. Missing points and deleted (back up) points will be noted. The user merely has to watch the screen.

### **Processing Body (Neck) Anthropometry.**

(1) Execute NPREP using processing option 2. NPREP is the main digitization and data acquisition program. It interfaces with the ALTEK™ digitizer to automate the digitization process and creates the NGIANT input image files for a particular subject. The operator may select the following options:

- 0: Initial Conditions
- 1: Head Anthropometry
- 2: Body Anthropometry

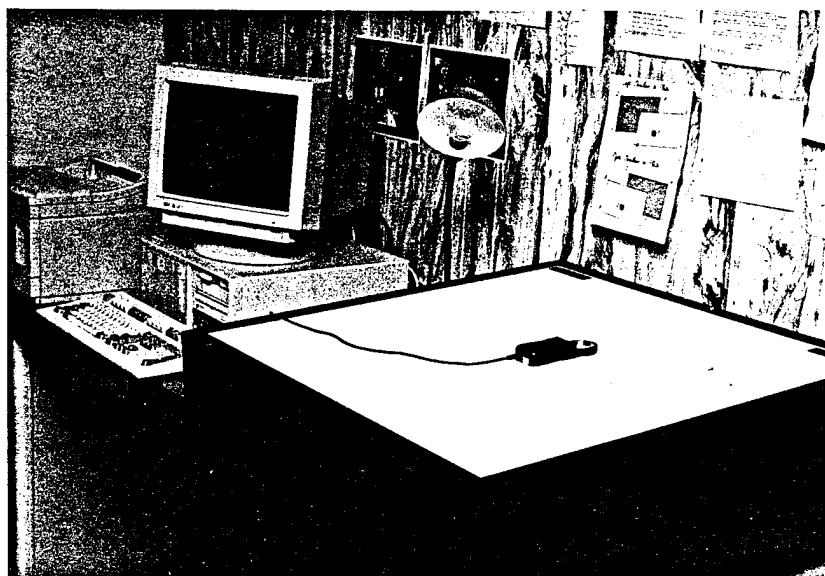

Figure 24  
Altek AC30 Digitizer Setup



Figure 25  
Digitizing an X-Ray



Figure 26  
Digitizer Cursor

## *Body X-Ray Anthropometry Manual*

---

To execute NPREP, type NPREP. The COMM port number for the ALTEK™ digitizer will be requested. Enter the number 2. The screen display will be as follows:

```
COM2: 9600, 0, 7, 2,-
```

```
Enter 0 for initial conditions.
```

```
Enter 1 for head anthropometry.
```

```
Enter 2 for body anthropometry.
```

Enter the number 2. The display will be: "Enter HRV number." The user will enter a four digit integer as the HRV number (i.e., 0222 would be entered for HRV number H-222). If a data file exists for the given subject, the program will terminate with the following:

```
File specified STATUS = "NEW" already exists  
(See Section 9.3 in Lahey Language Reference Manual
```

The filename, unit number, program and line number related to the error will also be printed.

To recover from an error termination:

- (a) Ensure the correct HRV number was entered.
- (b) If the HRV number is correct, check the data.
- (c) If the data is correct, you have processed the data for that HRV. NPREP will not write over that data.
- (d) If the data is incorrect, you will have to delete all data files created for that HRV and start over.

(2) If the data does not exist, processing will continue and the following will be displayed:

```
Enter number of parameters for shrinkage fit:
```

(3) The user will input the number 8, and the following will appear:

```
Enter 0 when finished  
Enter 1 if: Left eye view - left shoulder to plate  
Enter 2 if: Right eye view - left shoulder to plate  
Enter 3 if: Left eye view - right shoulder to plate  
Enter 4 if: Right eye view - right shoulder to plate
```

The number to be entered is determined by the x-ray being digitized. Numbers 1 through 4 indicate the four x-rays discussed earlier.

(4) The T-1 anatomical coordinate system (Fig. 1) and all other required BB's should have been marked on these x-rays in stereo before digitizing.

(5) The user will be requested to digitize the points as outlined below, depending on the date of the x-ray.

(6) The user must follow the script given above. There is no prompting. However, the data entered is printed on the screen to ensure proper entry.

(7) The user must check the screen to verify correct digitization.

(8) Fiducials 1 through 10 are entered first (see Fig. 27). The targets, from left to right, are entered

**NAVAL BIODYNAMICS LABORATORY TECHNICAL REPORT**

---

next. The controls, also going from left to right, are entered last; nrc1 is corner #1 on the right cube, nccl1 is corner #1 on the center cube, and nlc1 is corner #1 on the left cube (See Figs. 28, 29).

(9) Input Fiducial 1 through Fiducial 10 as indicated in Tables 1 - 3, remembering that there is no prompting. Input Fiducial 1 or the first visible fiducial carefully because you will have to re-enter this point to close out. Mark the first digitized point to ensure accuracy on termination. A root mean square error (rms) value will be printed. Check the rms value printed on the screen; it must be less than 1. If not, the data is erroneous and you must start over. Type Control-C to terminate the program. Delete and/or rename the data file and start over. If the rms value is less than one, press enter to continue as directed.

(10) Digitize the remaining points as outlined in Fig. 27 or Fig. 28, depending on the date of the x-rays. There will be no prompting. Input the data as follows:

**X-rays made before June 1992:**

- Origin (Anterior Superior Corner)
- Rib-lf (Left Rib Articulation)
- Rib-rt (Right Rib Articulation)
- Spine Top (Top Spinous Process)
- Spine Bot (Bottom Spinous Process)
- Spine-bb (Posterior Spinous Process)
  
- Sternum
- lf-shold (Left Shoulder)
- rt-shold (Right Shoulder)
- ltp (Left Side of T-Plate)
- rtp (Right Side of T-Plate)
- ctp (Center of T-Plate)
- lneckT (Left Neck Top) (Fig. 19)
- lneckB (Left Neck Bottom) (Fig. 19)
- rneckT (Right Neck Top) (Fig. 19)
- rneckB (Right Neck Bottom) (Fig. 19)

Re-do first fiducial (re-digitize the first point you digitized.)

Table 1. Digitizing Sequence for X-Rays Made before June, 1992	
Fiducials	1 2 3 4 5 6 7 8 9 10
Targets	Origin, Rib_Lf, Rib_Rt, SpineTop, SpineBot, spine_bb, sternum, lf_shold, rt_shold, lneckT, lneckB, rneckT, rneckB
Control	ltp, rtp, ctp

**Body X-Ray Anthropometry Manual**

<b>Table 2.</b> Digitizing Sequence for X-Rays Made after June, 1992, and before December, 1993	
<b>Fiducials</b>	1 2 3 4 5 6 7 8 9 10
<b>Targets</b>	Origin, Rib_Lf, Rib_Rt, SpineTop, SpineBot, spine_bb, sternum, lf_shold, rt_shold, lneckT, lneckB, rneckT, rneckB
<b>Control</b>	nrc1, nrc2, nrc3, nrc4, nrc5, nrc6, nrc7, nrc8, ncc1, ncc2, ncc3, ncc4, ncc5, ncc6, ncc7, ncc8, nlc1, nlc2, nlc3, nlc4, nlc5, nlc6, nlc7, nlc8

<b>Table 3.</b> Digitizing Sequence for X-Rays Made after December, 1993	
<b>Fiducials</b>	1 2 3 4 5 6 7 8 9 10
<b>Targets</b>	Origin, Rib_Lf, Rib_Rt, SpineTop, SpineBot, spine_bb, sternum, lf_shold, rt_shold, lneckT, lneckB, rneckT, rneckB
<b>Control</b>	Left Shoulder to Plate: nrc1, nrc3, nrc5, nrc7, nlc1, nlc3, nlc5, nlc7, ncc2, ncc4, ncc6, ncc8 Right Shoulder to Plate: nrc5, nrc7, nrc1, nrc3, nlc5, nlc7, nlc1, nlc3, ncc6, ncc8, ncc2, ncc4

**X-rays made before December 1993 using the new mount are processed as follows:**

Origin	(Anterior Superior Corner)
Rib-lf	(Left Rib Articulation)
Rib-rt	(Right Rib Articulation)
Spine Top	(Top Spinous Process)
Spine Bot	(Bottom Spinous Process)
Spine-bb	(Posterior Spinous Process)
Sternum	
lf-shold	(Left Shoulder)
rt-shold	(Right Shoulder)
lneckT	(Left Neck Top) (Fig. 19)

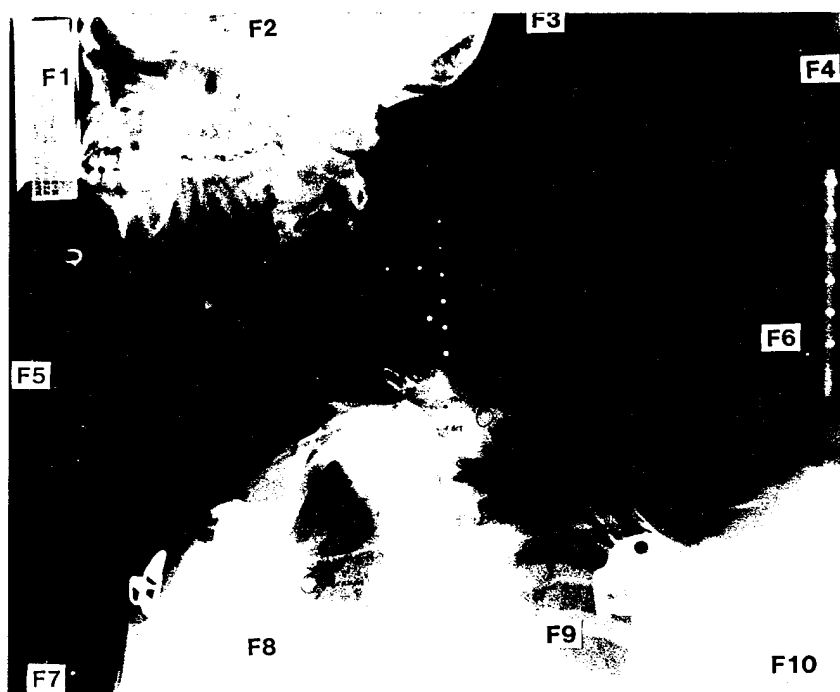

Figure 27  
Fiducials 1-10 on an X-Ray

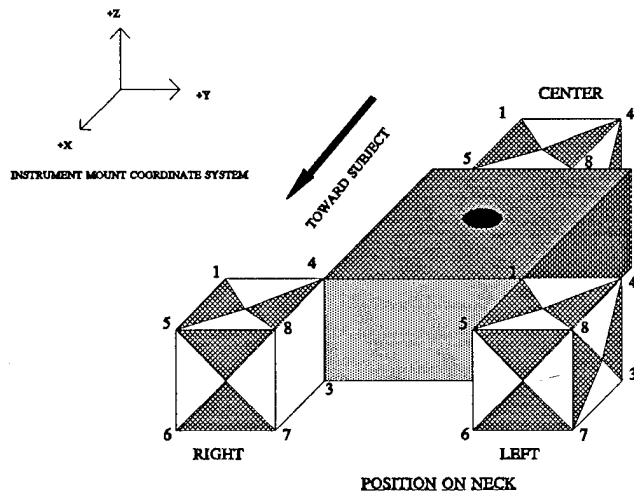

Figure 28  
Instrumentation Mount Corner Designations  
for Photogrammetry

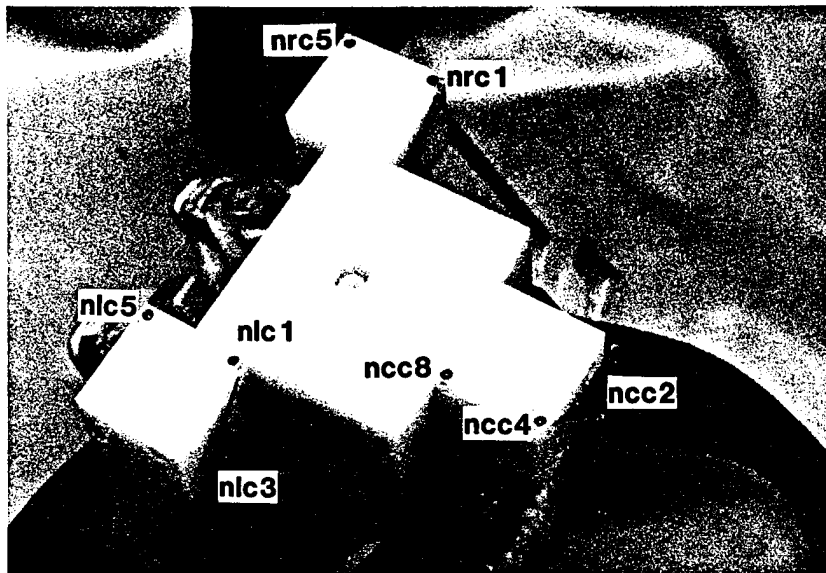

Figure 29  
Variable Names for Mount Corner Designations for Photogrammetry

## NAVAL BIODYNAMICS LABORATORY TECHNICAL REPORT

---

lneckB (Left Neck Bottom) (Fig. 19)  
rneckT (Right Neck Top) (Fig. 19)  
rneckB (Right Neck Bottom) (Fig. 19)

nrc1 (Neck Right Cube Corner 1)  
nrc2 (Neck Right Cube Corner 2)  
nrc3 (Neck Right Cube Corner 3)  
nrc4 (Neck Right Cube Corner 4)  
nrc5 (Neck Right Cube Corner 5)  
nrc6 (Neck Right Cube Corner 6)  
nrc7 (Neck Right Cube Corner 7)  
nrc8 (Neck Right Cube Corner 8)

ncc1 (Neck Center Cube Corner 1)  
ncc2 (Neck Center Cube Corner 2)  
ncc3 (Neck Center Cube Corner 3)  
ncc4 (Neck Center Cube Corner 4)  
ncc5 (Neck Center Cube Corner 5)  
ncc6 (Neck Center Cube Corner 6)  
ncc7 (Neck Center Cube Corner 7)  
ncc8 (Neck Center Cube Corner 8)

nlc1 (Neck Left Cube Corner 1)  
nlc2 (Neck Left Cube Corner 2)  
nlc3 (Neck Left Cube Corner 3)  
nlc4 (Neck Left Cube Corner 4)  
nlc5 (Neck Left Cube Corner 5)  
nlc6 (Neck Left Cube Corner 6)  
nlc7 (Neck Left Cube Corner 7)  
nlc8 (Neck Left Cube Corner 8)

### X-rays made December 1993 to present are processed as follows:

Origin (Anterior Superior Corner)  
Rib-lf (Left Rib Articulation)  
Rih-rt (Right Rib Articulation)  
Spinl Top (Top Spinous Process)  
Spine Bot (Bottom Spinous Process)  
Spine-bb (Posterior Spinous Process)  
Sternum  
lf-shold (Left Shoulder)  
rt-shold (Right Shoulder)  
lneckT (Left Neck Top) (Fig. 19)  
lneckB (Left Neck Bottom) (Fig. 19)  
rneckT (Right Neck Top) (Fig. 19)  
rneckB (Right Neck Bottom) (Fig. 19)

## *Body X-Ray Anthropometry Manual*

---

### Left Shoulder to Plate:

nrc1	(Neck Right Cube Corner 1)
nrc3	(Neck Right Cube Corner 3)
nrc5	(Neck Right Cube Corner 5)
nrc7	(Neck Right Cube Corner 7)

nrc1	(Neck Left Cube Corner 1)
nrc3	(Neck Left Cube Corner 3)
nrc5	(Neck Left Cube Corner 5)
nrc7	(Neck Left Cube Corner 7)

ncc2	(Neck Center Cube Corner 2)
ncc4	(Neck Center Cube Corner 4)
ncc6	(Neck Center Cube Corner 6)
ncc8	(Neck Center Cube Corner 8)

### Right Shoulder to Plate:

nrc5	(Neck Right Cube Corner 5)
nrc7	(Neck Right Cube Corner 7)
nrc1	(Neck Right Cube Corner 1)
nrc3	(Neck Right Cube Corner 3)

nrc5	(Neck Left Cube Corner 5)
nrc7	(Neck Left Cube Corner 7)
nrc1	(Neck Left Cube Corner 1)
nrc3	(Neck Left Cube Corner 3)

ncc6	(Neck Center Cube Corner 6)
ncc8	(Neck Center Cube Corner 8)
ncc2	(Neck Center Cube Corner 2)
ncc4	(Neck Center Cube Corner 4)

(11) When the last control point is entered, the following request will be printed:

Re-do first fiducial

Re-digitize the first point you digitized. Repeat steps 1 through 10 for each x-ray.

(12) Be sure to take your time when digitizing fiducial 1 or the first fiducial digitized. This is your close-out reference point. The first data point entered, which is also the last one entered, is read twice. The two values are compared to check the accuracy of the data. If the difference between the two values is greater than 2 mm, the origin has been lost. You will be given four tries to read the point correctly. After four tries, the program will terminate and all the data will have to be re-entered, because the x-ray must have moved during digitization.

(13) After all four x-rays have been digitized, execute NGIANT using processing option 2, body anthropometry.

All input files should be in place. The transformations from the anatomical to the instrumentation

## NAVAL BIODYNAMICS LABORATORY TECHNICAL REPORT

---

coordinate system are calculated. The operator may select the following options:

- 0: Initial Conditions
- 1: Head Anthropometry
- 2: Body Anthropometry
- 3: Standard GIANT™

After an option has been selected, the appropriate subroutine is executed. If option 0 is selected, the run number is requested. If option 3 is selected, a title for the GIANT™ output is requested. In both cases, GIANT™ is executed immediately after input, assuming all input files have been created. If option 1 or 2 is selected, an HRV number is requested. After receiving input, the files are searched for an image file named in the form "0222HIMG.DAT" or "0222BIMG.DAT," where 222 represents the actual HRV number. If the file exists, GIANT™ is executed. If the file does not exist, an error will be noted and execution terminated. The latter is also true for options 0 and 3.

(14) Perform data editing and bootstrapping, updating camera data with data calculated by GIANT™ until the standard deviations are 1 mm or less for the control data and approximately 2 mm for the target data.<sup>7</sup>

An *a posteriori* estimate of the variance of unit weight is calculated for each GIANT™ run. This is an important single number by which to judge a run. For a normal case, this number should approach 1.0. However, x-rays are somewhat different. An *a posteriori* estimate of variance of unit weight below 10.0 for x-rays taken before December, 1993, usually indicates good data. X-rays taken after December, 1993, usually have an *a posteriori* estimate of variance of unit weight below 3.5. Regardless of the date of the x-ray, the standard deviations should be checked using the criteria given above. These will indicate how low the values should be.

REFERENCES

1. GPA Associates, *Manual Of Close-Range Photogrammetric Techniques For The Naval Biodynamics Laboratory*, GPA, New Orleans, LA, p. 34, 1991.
2. *Manual of Photogrammetry*, American Society of Photogrammetry, Falls Church, VA, 1980.
3. Ibid, p. 1040.
4. Ibid, p. 1018.
5. Francis, D. A., *Operating Procedures for Anthropometry and Initial Condition Photogrammetric Program*, Research Report No. NBDL-90R010, Naval Biodynamics Laboratory, New Orleans, LA, March 1993.
6. Elassal, A. A. and Malhotra, R. C., *General Integrated Analytical Triangulation Program (GIANT) User's Guide*, Technical Report NOS126CGS11, U. S. Department of Commerce National Oceanic and Atmospheric Administration, Rockville, MD, 1987.
7. GPA Associates, *Manual Of Close-Range Photogrammetric Techniques For The Naval Biodynamics Laboratory*, GPA, New Orleans, LA, 1991.