

Naval Biodynamics Laboratory
NBDL-93R008

**MANUAL OF CLOSE-RANGE PHOTOGRAMMETRIC TECHNIQUES
FOR THE
NAVAL BIODYNAMICS LABORATORY**

GPA Associates

December, 1991

Naval Biodynamics Laboratory
P.O. Box 29407
New Orleans, LA 70189-0407

19960215 067



Approved for public release; distribution is unlimited.

Prepared for

Naval Medical Research and Development Command
Bethesda, MD 20889-5044

DMC QUALITY INSPECTED 1

DISCLAIMER NOTICE

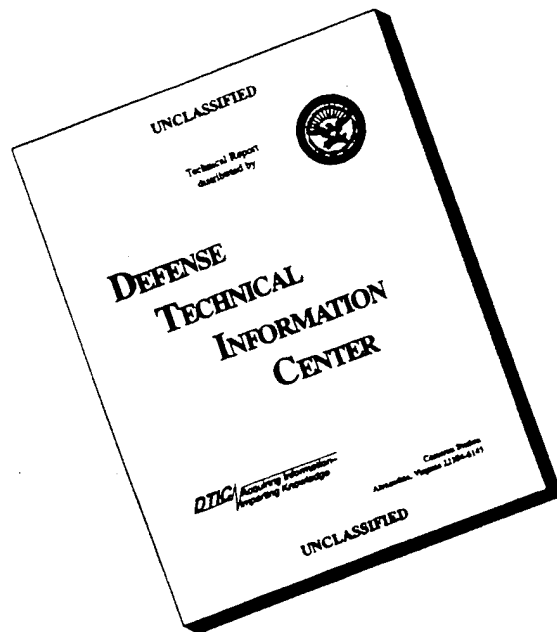

THIS DOCUMENT IS BEST QUALITY AVAILABLE. THE COPY FURNISHED TO DTIC CONTAINED A SIGNIFICANT NUMBER OF PAGES WHICH DO NOT REPRODUCE LEGIBLY.

**MANUAL
OF
CLOSE-RANGE
PHOTOGRAMMETRIC
TECHNIQUES
FOR THE
NAVAL BIODYNAMICS
LABORATORY**

December 1991

GPA Associates

Geodetic/Photogrammetric Analysis Associates

UNO Box 1200

New Orleans, LA 70148-1200

(504) 286-1200

TABLE OF CONTENTS

Part I: Analytical Calibration of Non-Metric Cameras.	1
Introduction.	
Chapter 1: Interior Orientation.	2
Principal Points.	
Focal Length.	
Fiducials.	
Chapter 2: Sources of Systematic Error.	10
Radial Lens Distortion.	
Part II. Site Survey.	13
Chapter 3. Site Survey for the 35mm Camera System on the Vertical Accelerator.	14
Part III. Head Anthropometry by Optical Photogrammetry.	17
Chapter 4. Historical Considerations.	17
Chapter 5. The Optical Process.	19
Part IV. Body Anthropometry by Stereo X-Ray Photogrammetry.	22
Chapter 6. Historical Considerations.	22
Chapter 7. Body X-Ray Photogrammetry.	24
The Chair.	
The Subject.	
The X-Ray Film Carrier Frame	
The X-Rays.	
Digitizing.	
Part V. Determination of Initial Conditions.	31
Chapter 8. Historical Considerations.	31
Chapter 9. 35mm Camera System for the Determination of Initial Conditions	32

Part I: Analytical Calibration of Non-Metric Cameras

Introduction

Photogrammetric determination of initial conditions of human research volunteers, of head anthropometry, of positioning for the ship motion simulator (SMS) or for site surveys is dependent on a variety of factors that includes the calibration of the camera systems.

Metric cameras are fixed-focus, with a lens permanently mounted to the cone holding the focal plane. They come pre-calibrated and very expensive. Non-metric cameras constitute the vast majority of existing cameras and do not come with a calibration certificate. Calibration is essential for high-precision photogrammetric applications.

Camera calibration involves a group of observations with the objective of determining the interior orientation of a lens/camera configuration along with any systematic errors present. In any photogrammetric system, one attempts to model all sources of systematic error so that subsequent determinations of dimensions and coordinates in object space are affected only by random or Gaussian distributions of error. The major sources of known systematic error that a camera calibration should model are:

- 1: Offset of the principal point,
- 2: Film shrinkage,
- 3: Focal length, and
- 4: Radial & tangential lens distortion.

Chapter 1: Interior Orientation

Principal Points

There are several principal points that are referenced in the literature and can be found in various types of camera calibrations. A fiducial is a well-defined point that appears within the format border of the photograph and remains constant from one photograph to another. The Indicated Principal Point (IPP) is that point indicated by the intersection of imaginary lines connecting the fiducial points. On metric cameras, fiducials are generally found on corners, midpoints on the sides, or both. On non-metric cameras, fiducials are commonly taken to be the format corners. The Principal Point of Autocollimation (PPA) is that point indicated by the reticle (crosshairs) of an autocollimated telescope in the film plane. These will be discussed later.

To determine the PPA, the camera must photograph crosshairs projected perpendicular to the film plane from infinity. Some of the mechanical difficulties in holding the camera steady are that it

requires a firm torque to attach and rotate bayonet-mount lenses to the mechanical stop and requires a lot of manipulations to load and advance film in a 35mm camera. Optical tooling stands with specially-machined bolts and studs were tried to no avail; the solution is a monolithic optical bench and a type of mount system used for high-speed photography called an "MO-3 Block" (Fig.1-1).

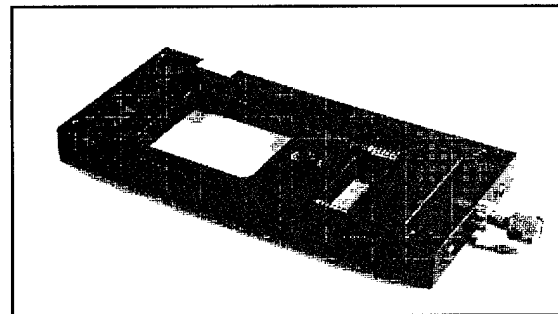

Figure 1-1

A beveled-edge aluminum plate is attached to the tripod mount on the camera (Fig.1-2) and is then clamped into the "MO-3 Block".

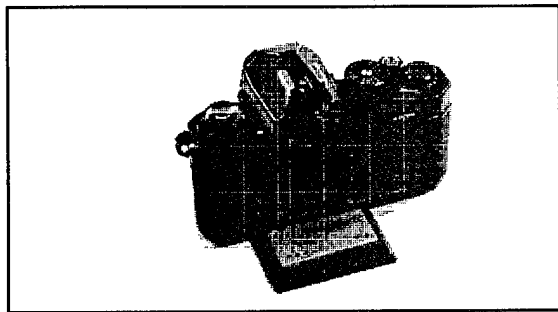

Figure 1-2

The beveled-edge plate was fitted with a jamb stop (Fig.1-3) against which the camera is forced as a countersunk machine screw is tightened into the tripod mount hole.

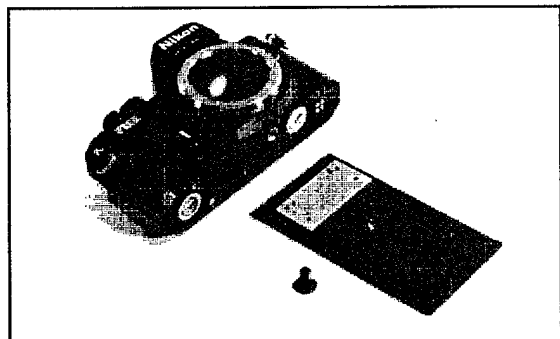

Figure 1-3

The "MO-3 Block" is attached to a tilt-stand which is integral with an optical bench (Fig.1-4).

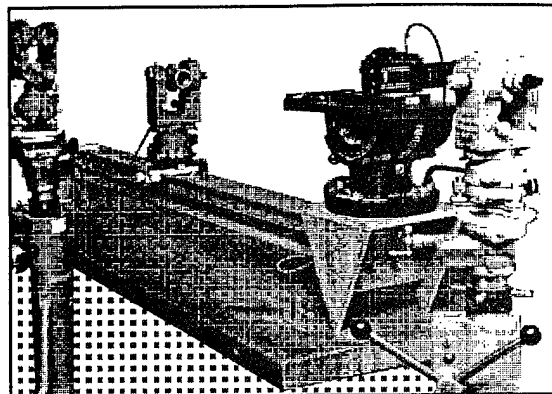

Figure 1-4

The process of autocollimation for the determination of the principal point requires an optically-flat ($1/4$ wave to $1/8$ wave) front surface mirror be placed in the film plane of the camera (Fig.1-5).

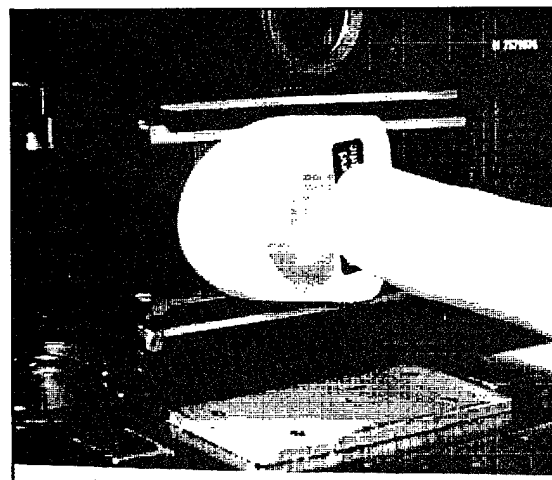

Figure 1-5

Sighting may be done with either a jig transit or collimator or theodolite. The theodolite used is shown (Fig.1-6).

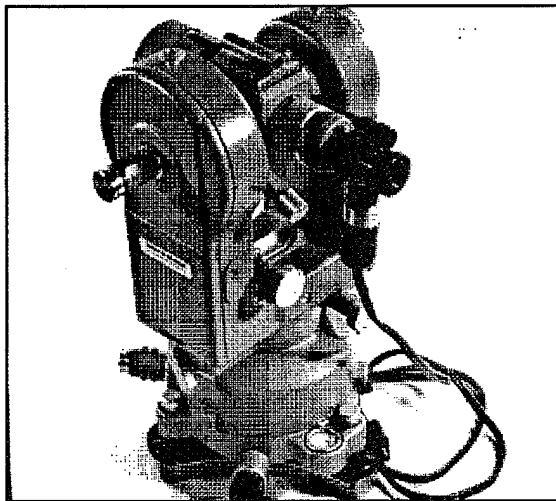

Figure 1-6

The theodolite is fitted with an autocollimating eyepiece (Fig.1-7) that is used to view the mirror in the film plane of the camera with the lens removed.

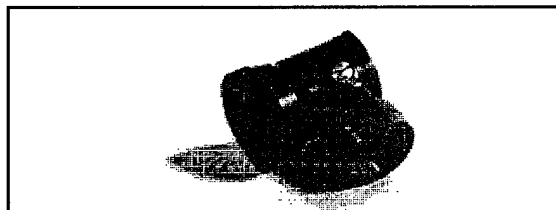

Figure 1-7

A threaded stud was machined onto an optical bench clamp (Fig.1-8).

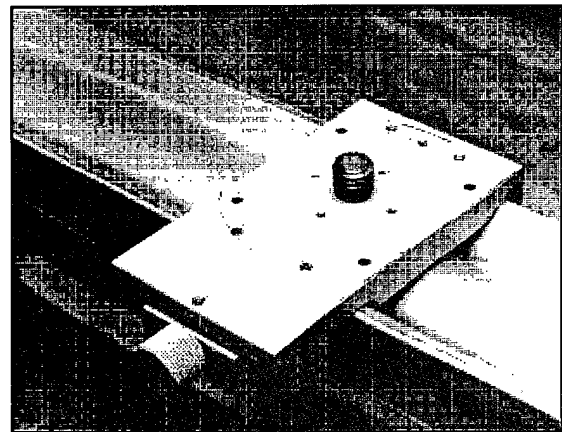

Figure 1-8

The theodolite is then attached to the clamp (Fig.1-9).

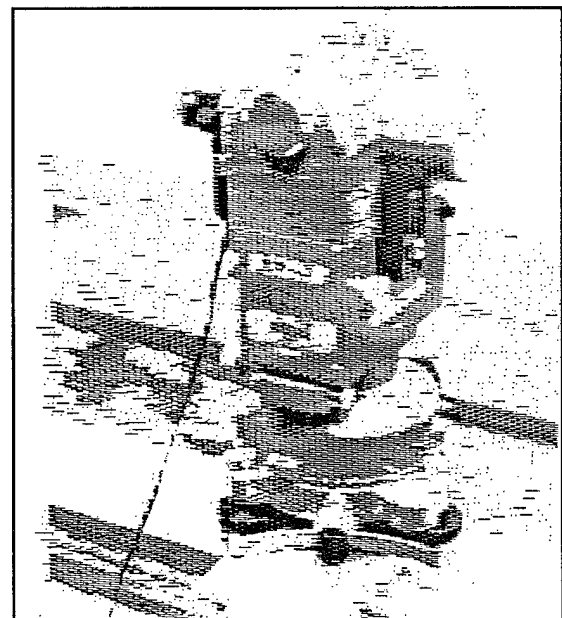

Figure 1-9

The eyepiece lens must be adjusted first to bring the crosshairs into focus (Fig.1-10).

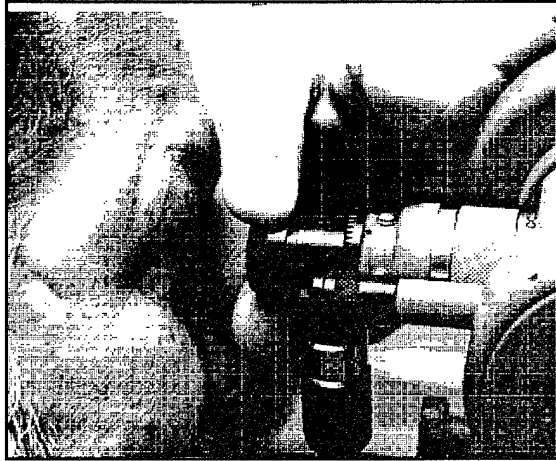

Figure 1-10

A silhouette of the crosshairs is projected through the objective lens of the theodolite towards the mirror on the focal plane of the camera.

The telescope is then focused at infinity by adjusting the objective lens (Fig.1-11) until the reflection of the crosshairs appears in focus.

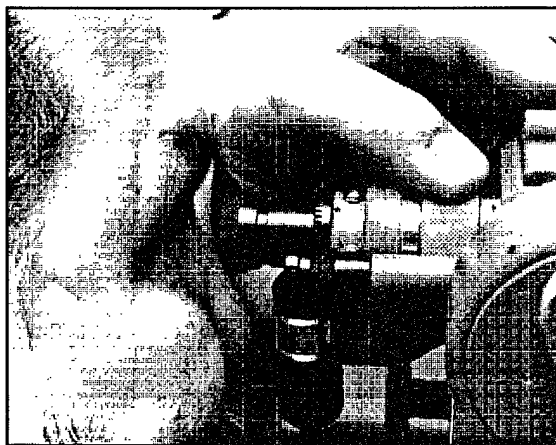

Figure 1-11

The telescope (theodolite) is now a collimator, and the image is the reflection of a collimator with the crosshairs somewhere in the crosshair plane (Fig.1-12).

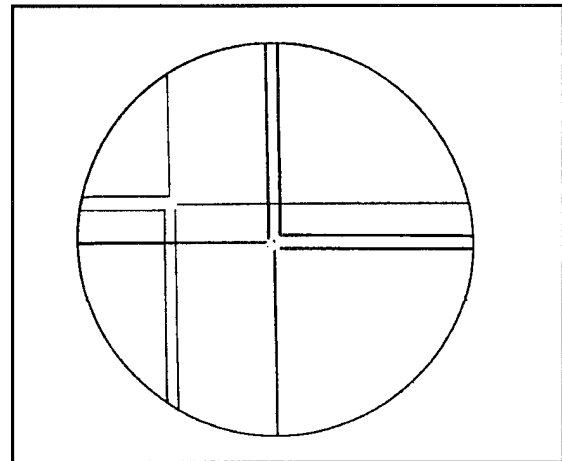

Figure 1-12

To insure that no optical parallax remains, the observer must move his head transversely (up-down and left-right) within the exit pupil field of view while observing the crosshairs.

The mirror is adjusted to bring the reflection of the crosshairs on top of the actual crosshairs, insuring that the mirror is perpendicular to the line of sight. The reflected crosshairs will have the same thickness as the actual crosshairs, since the magnification is 1:1. They do usually appear to be slightly fainter than the actual crosshairs.

Often the crosshair pattern in an autocollimation telescope has one half of the horizontal hair as a double line and one half of the vertical hair as a double line. The actual image formed when autocollimation is achieved is three equally spaced crosshairs appearing for the top and bottom/left and right halves of each crosshair (Fig.1-13).

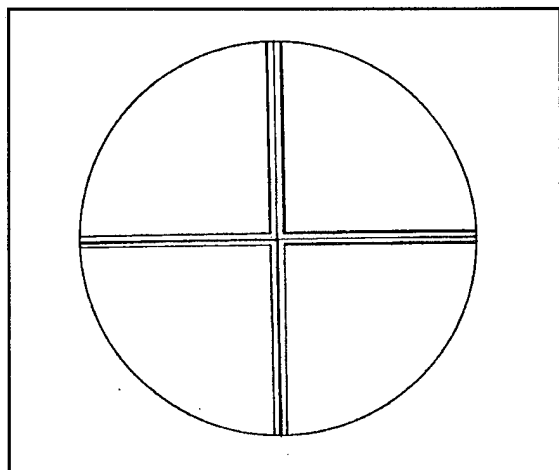

Figure 1-13

Once autocollimation has been achieved, the next step is to measure the location of the projected crosshairs with respect to the fiducials/format corners in the film plane. Precision photogrammetric equipment, in particular, a 1-micrometer comparator, is available at the Topographic Engineering Laboratory of the University of New Orleans. The simplest

method to locate the principal point of autocollimation is to use this comparator to measure a photographic negative of the imaged crosshairs and the format corners, as in the sketch (Fig.1-14).

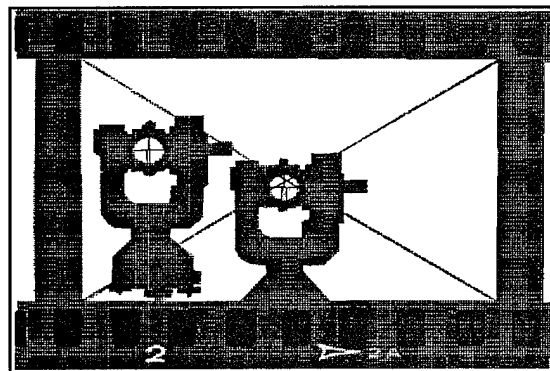

Figure 1-14

The film is loaded into the camera without disturbing or moving the camera in any way (Fig.1-15).

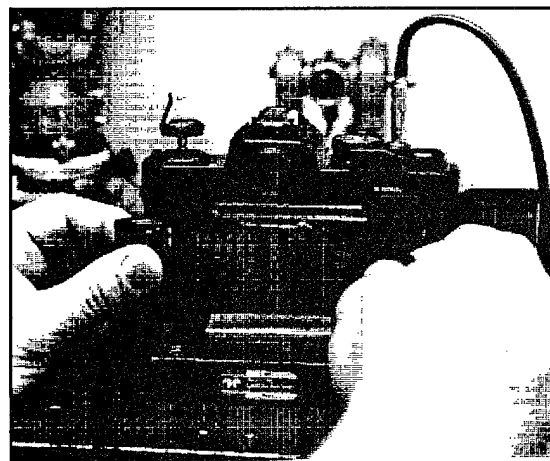

Figure 1-15

The lens is now attached (Fig.1-16).

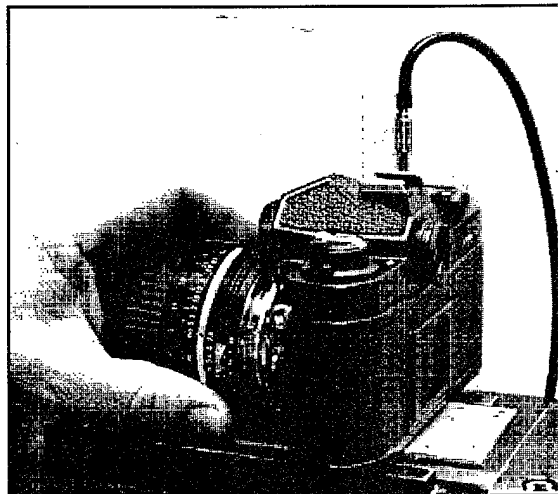

Figure 1-16

If the camera or any theodolite is disturbed, start over!

Proper illumination and aperture settings were difficult to predict so a series of varying exposures were made to bracket a reasonable range so that the crosshairs could be discerned by the microscope on the monocomparator. In addition to the autocollimator reticle being exposed, a white poster board was erected behind the collimator and illuminated so that the format corners (fiducials) would be discernible on the film negative.

Focal Length

The focal length of the lens (labeled as 55mm) is a critical parameter in photogrammetric restitution; the determination of the Equivalent Focal Length (EFL) is done optically rather than by direct physical measurement with micrometer depth gauges. Based on additional observations and computations for radial lens distortion; the EFL is used for the determination of the Calibrated Focal Length.

The convention followed for the determination of Equivalent Focal Length is to first examine the radial lens distortion characteristics of the lens and determine what approximate radial distance/angle of incidence is essentially "distortion-free". As a basis of comparison for cartographic-quality metric cameras, the distortion-free angle of incidence is approximately 7.5 degrees. With this generally defined for a particular class of lens, the EFL is determined by an off-axis collimator focussed at infinity and inclined to the film plane by the maximum distortion-free angle of incidence. The exposure made for the determination of the Principal Point of Autocollimation

and the Indicated Principal Point is also used to determine the EFL by the addition of an off-axis collimator positioned at an angle of incidence determined by the particular lens distortion characteristic of these 55mm lenses. The orientation of the three theodolites (the third one to measure the angle between the first two) relative to the camera is shown (Fig.1-17).

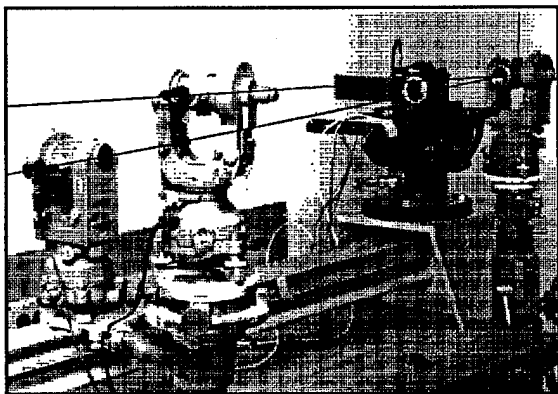

Figure 1-17

Excluding wide-angle lenses, the angle of incidence is generally no more than about 10°.

Because the camera is relatively fixed, autocollimation is achieved by adjusting the horizontal and vertical tangent screws of the autocollimating theodolite. This means that for each camera brought into autocollimation, the angle of incidence between the

autocollimator and the off-axis collimator will vary. This therefore necessitates that the horizontal and vertical angles between the two collimators be measured by another theodolite after the camera is removed from the "MO-3 Block" (Fig.1-18).

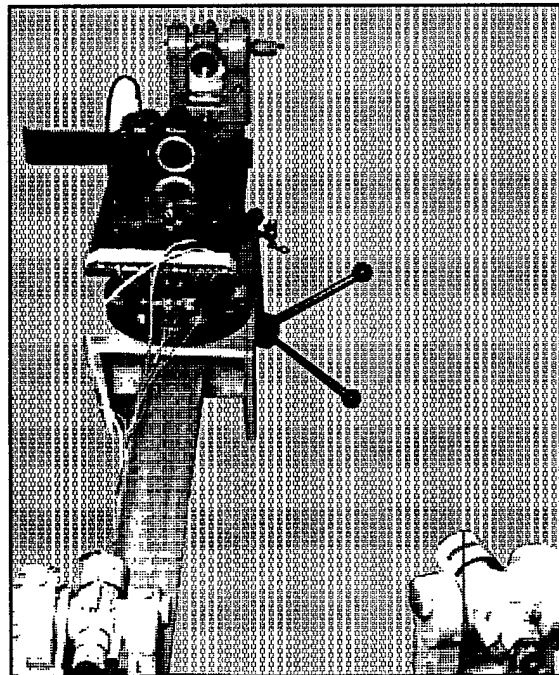

Figure 1-18

The angle subtended is then computed by spherical trig:

$$\cos(\text{ang}) = \cos(v_1) * \cos(v_2) + \sin(v_1) * \sin(v_2) * \cos(h),$$

where v_1 and v_2 are the vertical angles of the theodolites measured from the zenith, and h is the horizontal angle between

the two. The tangent of this subtended angle is equal to the distance on the negative divided by equivalent focal length within the "zero distortion" area of the lens.

Fiducials

The correction for film shrinkage is based on measurement of control negatives that presumably have a near-perfect correspondence with identifiable features in the camera. For elaborate and costly cartographic-quality cameras, the identifiable features are called fiducials (reference points) which indicate the principal point (intersection of the optical axis with the film plane). For non-metric (non-cartographic-quality) cameras, a reasonable alternative to fiducials is the use of the format corners. Depending on the design and fabrication of the individual camera, the format corners may be or may not be easily measured as discrete points. Alternatively, several points are measured on each of the format edges and a least-squares regression is done on each edge. These lines are intersected to give the corners. This is done in a software program called FID.

The traditional method of establishing control for dimensions between fiducials is to expose a photo-sensitized glass plate in the film plane, develop the imagery and then measure fiducial coordinates on a one-micron comparator. For the sake of practicality, polyester-based film was used instead of glass plates and was hand-processed at 68°F & air dried. Film used was Kodak Technical Pan Film Estar-AH Base Emulsion Number 086012C06C. The original negatives were then measured on a one-micrometer comparator (MANN 422F) and averaged based on three different exposures/negatives on the same film strip, the photo of the crosshairs and the two photos for the determination of lens distortion discussed in the next chapter. The software program FLASH determines this average. All three are run through NPREP to determine the adjusted image coordinates. Other observations were made on the first of these negatives at the same time for the determination of the principal point of autocollimation and for the equivalent focal length. The edited NPREP output is needed for the CAL package discussed in the next chapter.

Chapter 2: Sources of Systematic Error

Radial Lens Distortion

The horizontal component of lens distortion may be determined by examining how far images of vertical lines differ from being vertical. True vertical lines may be obtained by using plumb lines-strings with a weight attached. The weights are suspended in oil to damp out vibrations and oscillations. Five lines are spaced at approximately equal intervals (10%, 30%, 50%, 70% and 90%) across the field of view of the camera. Two additional lines are placed at the edges of the field of view (0% & 100%) to aid alignment.

The field width (or height) is the camera-to-string distance multiplied by the ratio of the negative format width (or height) to the focal length of the lens.

Five horizontal strings (plus two for alignment) are spaced vertically across the field in a similar fashion to locate 25 intersection points. Photos are taken of these arrangements (Fig.2-1).

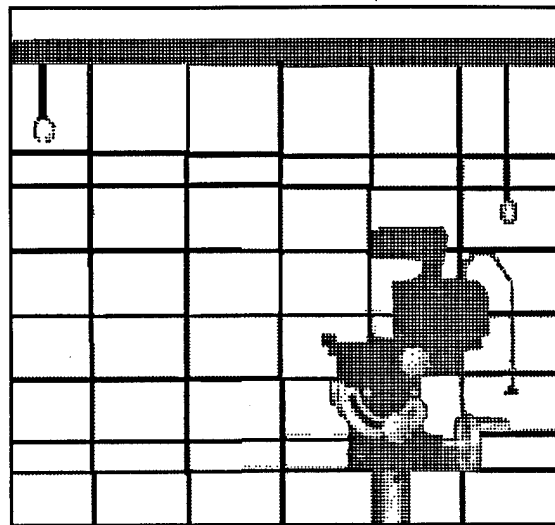

Figure 2-1

The cameras are then rotated 90°. The string placements are changed for the new format, portrait vs. landscape. The vertical line spacings are now the horizontal spacings and vice versa, so that the 25 intersections on each rotated frame still are in approximately the same position on the rotated negative. To aid in the placement of the strings, a wooden frame was constructed edged with serrated saw teeth, as shown in the photo (Fig.2-2).

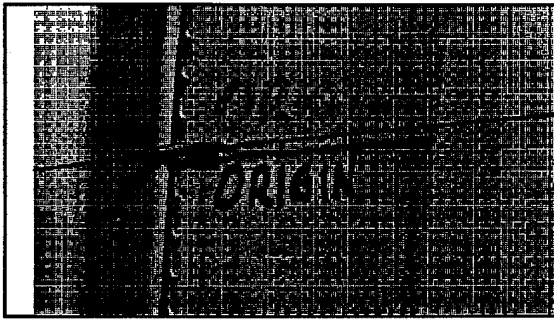

Figure 2-2

Another photo is taken to show camera and lens serial numbers and to record the angles measured between the two theodolites (Fig.2-3).

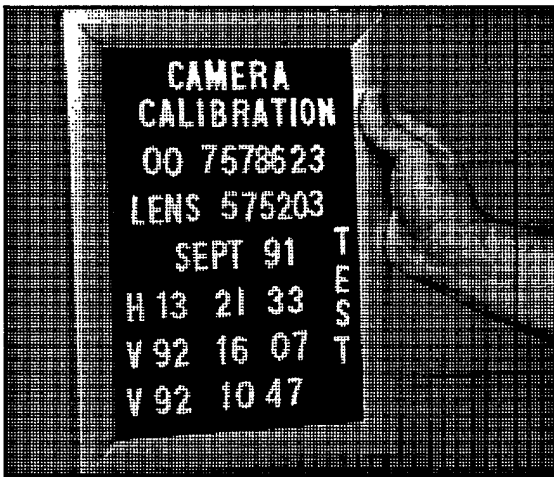

Figure 2-3

The images were then digitized on the MANN comparator. A software program (FLASH) was written to take the

three frames (PPA plus the two plumb-lines) and to find the IPP (Indicated Principal Point) and the calibrated fiducials, which are used by the NGIANT preprocessor (NPREP) to correct for film shrinkage. The PPA frame is then run through NPREP to solve for the coordinates of the PPA in the calibrated fiducial coordinate system. This is the offset of the principal point needed for all subsequent NPREP runs with this camera.

Considering each vertical string separately, a least squares adjustment is done on the image to determine the deviation of the five points from vertical. Repeating for each of the five strings, we get the 25 horizontal deviations. Holding the portrait picture in landscape orientation and fitting the five strings to horizontal lines gives the vertical deviations for the same 25 points. These are combined vectorially and split into radial and tangential components. Each of these may be considered as functions of radius and fitted to polynomials as required by the NGIANT pre-processor.

The expression for radial distortion as used by NPREP is

$$dr = fk_0 * r^1 + fk_1 * r^3 + fk_2 * r^5 + fk_3 * r^7,$$

where the coefficients fk_i are to be determined.

Tangential lens distortion as modelled by NPREP is negligible. Some small amount of barrel distortion can be found in the 55mm Micro-Nikkor lens, but it is not significant enough to change the model. Wide-angle lenses, such as the 24mm Nikon lens, show considerably more barrel distortion and its use for photogrammetric purposes might warrant such a change.

A software program (CAL) was written to perform these calculations and to graphically display the results on the screen and to write a plot file for GRAPH.

Part II. Site Survey

Photogrammetric analysis requires the establishment of an object space coordinate system in order to express the position and attitude of the cameras with respect to known (control) and unknown (pass) points.

Photogrammetric systems designed for minimally-determined (unique) solutions demand that elaborate high-precision optical tooling techniques be used to establish control. Highly over-determined solutions need far less brute force and can be easily obtained using NGIANT to perform the survey.

Chapter 3. Site Survey for the 35mm Camera System on the Vertical Accelerator

The vertical accelerator has a pre-existing "Laboratory Coordinate System" with an origin under a plate on the floor of the vertical accelerator and has points surveyed to a cube in this system. These points were used, but a photogrammetric solution could just as easily be performed from any origin. However, these points are not sufficient for a proper photogrammetric solution. Control point locations must be found to cover the entire field of view for all cameras and each such point must be seen by two or preferably more cameras.

Experience suggested that a six-camera array should be able to view needed control and targets on both the head and neck and have a large number of degrees of freedom to give a very well-behaved solution. The locations of these cameras are determined by the requirements of a "good geometry," that the array be highly convergent on all targets. Two cameras are placed in front of the subject and two on each side and tests are made of their field of view, as shown in the sketch (Fig.3-1).

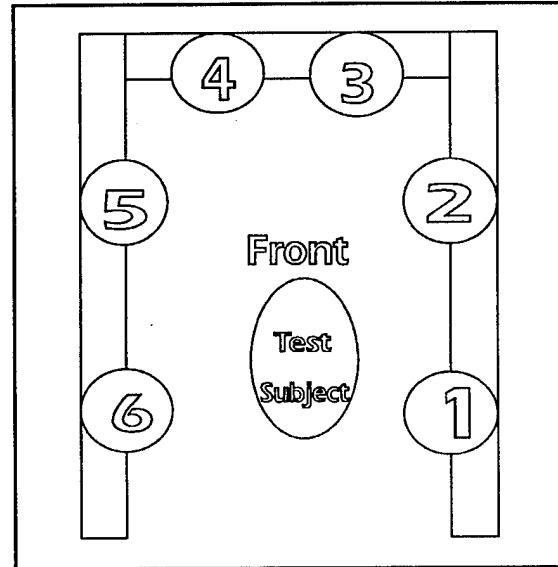

Figure 3-1

A simulation test may be made of the geometry with NGIANT, forcing unit variance to one and looking at the GDOP (geometric dilution of precision).

Interim control is introduced by the use of a "spyder," a machined cube with machined extensions into the three-dimensional world. This is physically aligned and attached to the known cube so that the points on the spyder become known by a simple translation vector (Fig.3-2).

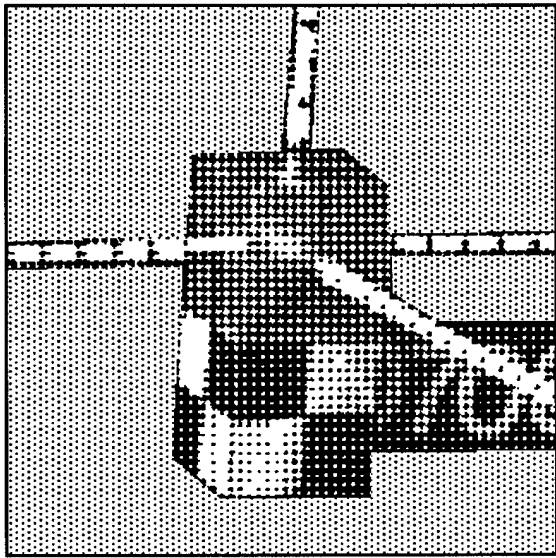

Figure 3-2

The two other cubes mounted on the vertical accelerator are potential control points since their corners are easily identified. Additional survey targets and labels are then placed on anything that doesn't move provided it appears on two or preferably more frames.

NGIANT moves the cameras for best fit, but a fairly good guess of camera position and attitude is necessary to start the process. Cloth tape measurements give the camera positions well enough, but camera attitude is expressed in roll, pitch and yaw - simple to visualize for aerial

photogrammetry but not for terrestrial. Azimuth, elevation and swing are better suited for land-based applications so a program (ANG) was written to convert from one to the other. These angles are estimated for each camera to within about 10° .

The cameras are loaded with film and fired. The view from camera number three is shown in Figure 3-3

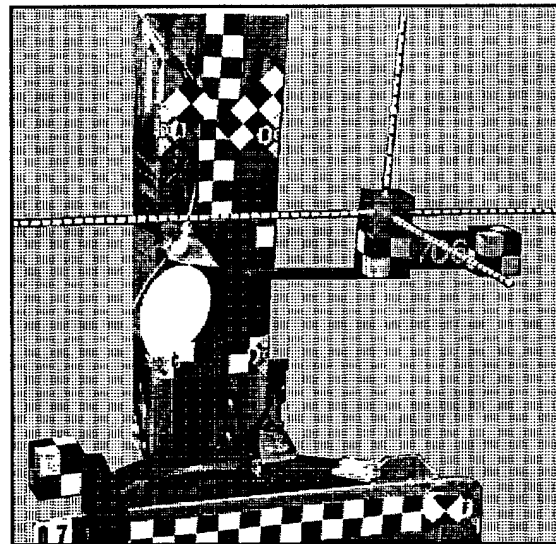

Figure 3-3

and that from camera number four is shown in Figure 3-4.

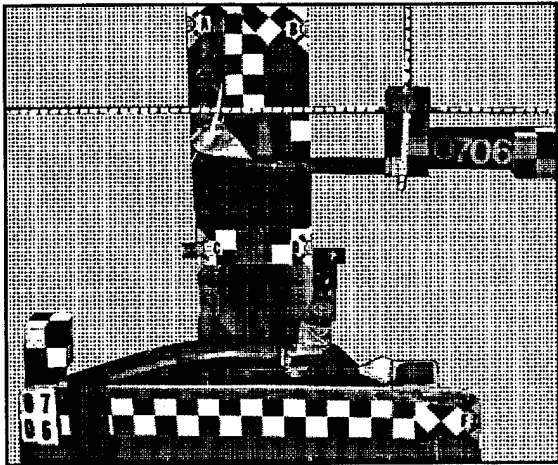

Figure 3-4

The negatives were digitized on the MANN monocomparator and run through NPREP and NGIANT. The output coordinates for the two additional cubes and for the survey targets are now determined by this site survey and can be considered as control for future triangulation adjustments. These are entered as control into the options file for NGIANT as well as the triangulated positions and attitudes for the six camera stations.

Part III. Head Anthropometry by Optical Photogrammetry

Chapter 4. Historical Considerations.

Head anthropometry is the establishment of a coordinate system fixed within the skull at its approximate center of mass and aligned with the head. The origin of this coordinate system is defined as the mid-point of the line connecting the auditory meatus in the left ear with that in the right ear. The x-axis proceeds to the mid-point of the notches on the inferior orbital ridges (below the eyes). The y-axis is perpendicular to the x-axis in the plane with the ears and coming out of (approximately) the left ear. The z-axis is up, determined by the right-handed cross product of the x-axis with the y-axis (Fig.4-1).

Up until a couple years ago, x-rays were taken of a subject with lead b-b's taped to the skin covering the ocular notches and with lead b-b's inside of tubes inserted deeply into the ear canal to approximate the meatus. Other b-b's were located on a radiolucent mount attached to a custom-fitted bite-

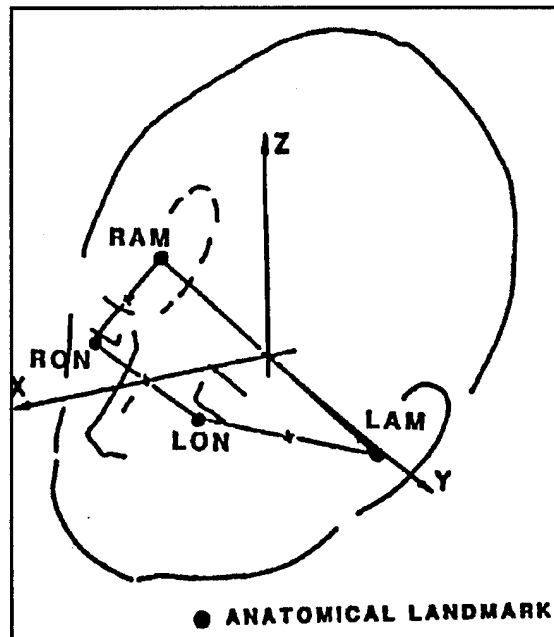

Figure 4-1

plate in the subject's mouth. The three b-b's on this mount determined the instrumentation coordinate system. The two x-rays were taken from the front (A/P or anterior/posterior) and from the side (Lateral). Two more x-rays (A/P and Lat) were taken of a radiolucent prism with thirteen b-b's (five in common) at known positions on the prism. These constituted the dimensional control for the series.

Critique. Five points in stereo constitute a unique solution of the geometry with zero degrees of freedom. Two-ray intersections in space offer no error-checking facility, and blunders require at least re-doing the entire mensuration procedure and perhaps redoing the x-rays.

Two extra x-rays (A/P and Lat) were made with the subject turned at an angle of approximately 45° , improving the camera geometry. Additional b-b's were placed on the subject's head and neck and on special "tusks" running back to the neck from the mouth mount. Additional points were added to the calibration prism.

Numerous film shrinkage marks were added to each x-ray cassette. The software package NGIANT was brought in to perform a least-squares adjustment on all x-ray photos and to analyze the geometric dilution of precision (GDOP).

Critique. The geometry of the system improved as numerous degrees of freedom gave improved solutions with error propagation analyses for each run. Approximate errors were on the order of 1mm locating the b-b's of interest and in determining the displacement and the transformation matrix connecting the head and instrumentation coordinate systems. The solution was much improved at the expense of additional irradiation of the eyes of the test subject.

So the question then became: Why x-rays?

Chapter 5. The Optical Process.

The b-b's on the mouth mount and next to the ocular notches can be seen and hence photographed optically. Only the b-b's in the ear canals were not visible. It then became apparent that one could infer their positions by observations on targets rigidly attached to the b-b's but extending out of the ear to where they could be seen. Experimental tests were made on several designs, resulting in one which was reliable to use and easy to fabricate (Fig.5-1).

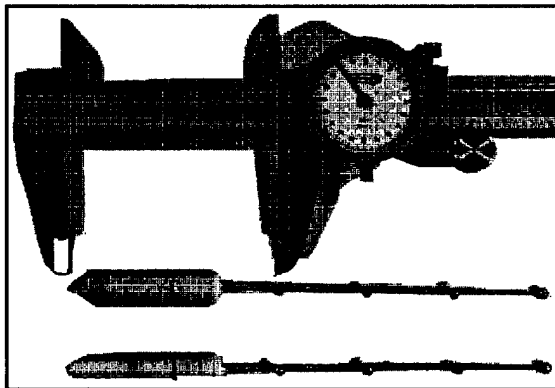

Figure 5-1

The optical photogrammetry system under development for the initial conditions of accelerator runs was thought to be perfect for this task also. Control points for a simultaneous

block adjustment of the six-camera system have already been determined from the site survey and are loaded into the 35mm options file for NGIANT as well as the camera locations and attitudes.

A test subject is seated on the vertical accelerator chair. The ocular notches are found and marked with a felt-tip pencil (Fig.5-2).



Figure 5-2

Ear plugs with the ear targets attached are inserted by the subject under doctor's supervision (Fig.5-3).



Figure 5-3

The ear plug is marked to indicate the proper depth. The b-b targets on the x-ray mouth mount can serve just as well as visual targets (Fig.5-4).

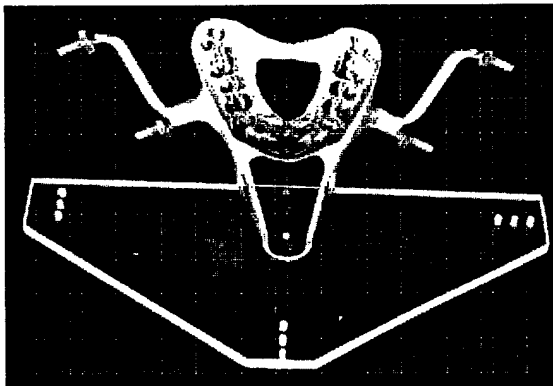

Figure 5-4

The subject inserts the bite plate

part of the mouth mount assembly into place (Fig.5-5).

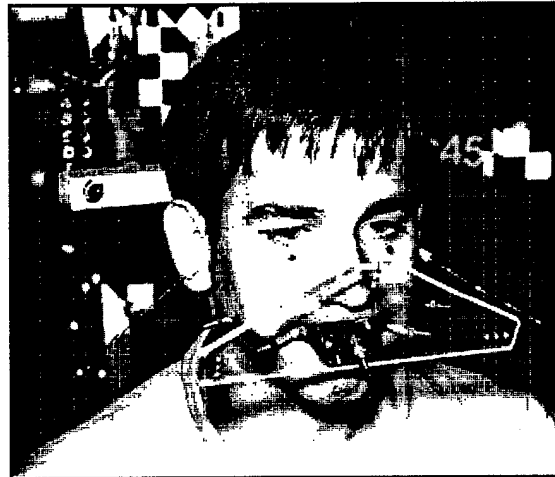

Figure 5-5

He uses a sports mouth piece to support the bite plate in place (Fig.5-6).

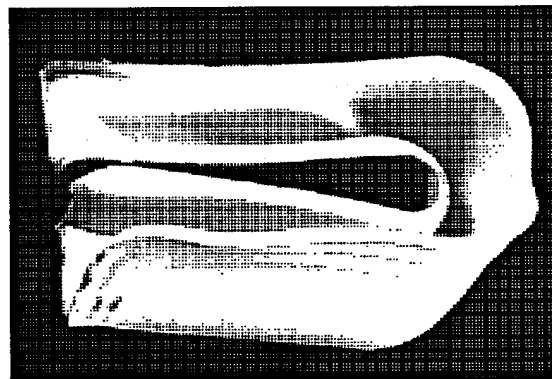

Figure 5-6

One can see from Figure 5-5 that all important eye, ear and mouth targets are visible in this view as

well as control points in the background. All six camera shutters are fired simultaneously. The film is processed and enlargements made showing all format edges of each negative on the prints. These are digitized on the ALTEK digitizer (as described later) using NPREP. This creates the image file for NGIANT for a particular subject (by HRV number). NGIANT will find all the needed points in space and compute the locations of the inner ear points by regression on the x, y, z coordinates of the ear targets. It then has all the information to calculate the transformation from head anatomical to instrumentation coordinate systems.

Part IV. Body Anthropometry by Stereo X-Ray Photogrammetry.

Chapter 6. Historical Considerations.

Body anthropometry is the establishment of a coordinate system fixed within the body at the first thoracic vertebral body (T-1). The origin of this coordinate system is defined as the anterior superior corner and the negative x-axis runs from the origin through the mid-point of the line between the upper and lower posterior spinous process. The y-axis lies in the plane of and perpendicular to the x-axis and the line connecting the two articular facets (positive left). The z-axis (up) is x-axis cross y-axis (Fig.6-1).

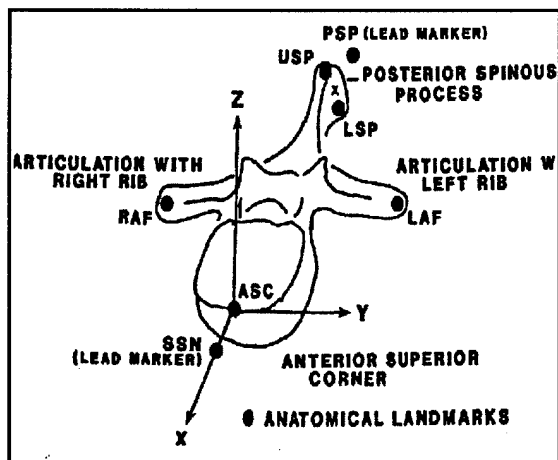

Figure 6-1

The original method was to use two simultaneous x-rays of the subject, one taken laterally and one anterior-posterior (A/P). So much of the body had to be penetrated by the lateral x-ray that none of the defining points were visible in this view. A very round-about method was needed and devised to circumvent the lack of adequate data. The front and side views were used to make the mathematics simpler and not out of necessity.

A new method was proposed and after several trials with associated errors, two pairs of stereo x-rays were to be used in the future, with each pair approximately 45° on opposite sides of the A/P direction. There are several reasons for this configuration. X-rays at 45° did not have to penetrate as much bone mass as in the lateral whereas straight A/P x-rays were not passing through enough bone. A point appearing on two x-rays has a unique solution with no indication of the error

associated with that value. The same point appearing on four x-rays has additional degrees of freedom for a good photogrammetric solution including error propagation. Photo-identification of a discrete point can be enhanced by the stereo viewing process.

Again, a desire to obviate the need for x-rays at all prompted questions of doing body anthropometry by optical means. X-rays to the chest are not nearly as potentially harmful as to the head. Many of the needed points for the definition of the body coordinate system are just not accessible to optical cameras.

Chapter 7. Body X-Ray Photogrammetry.

The desire to duplicate the physical conditions occurring during an acceleration run prompted a more careful look at all of the circumstances of the anthropometric process.

The Chair

If the subject slumps in the chair during the x-rays, conditions could be sufficiently altered so that the resulting transformations from body to instrument coordinate systems might not be valid for the actual acceleration runs. Furthermore, it was found many subjects were unable to maintain the identical posture and pose between the two views of a stereo pair, particularly, several b-b's placed on the subject's neck (Fig.7-1).



Figure 7-1

A new chair (Fig.7-2)

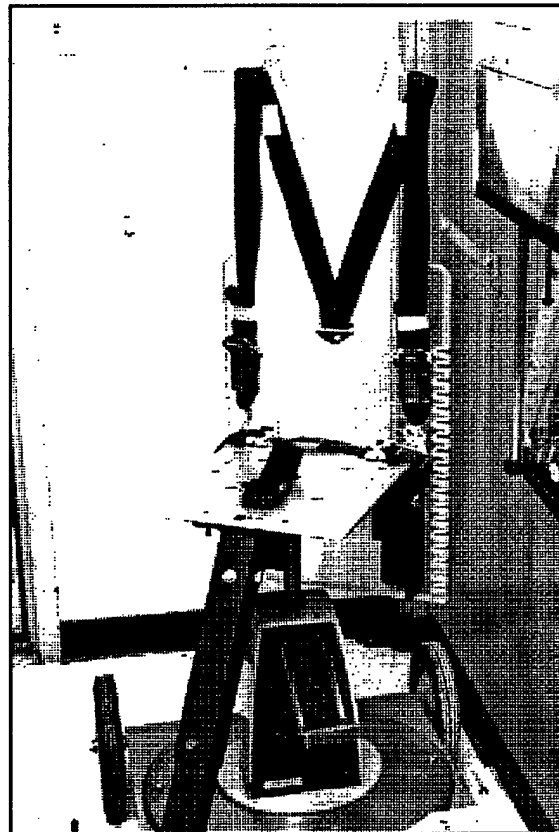

Figure 7-2

was designed to simulate the chair on the accelerator, including the ability to raise or lower the subject so his vertical position is the same independent of his actual height (Fig.7-3).

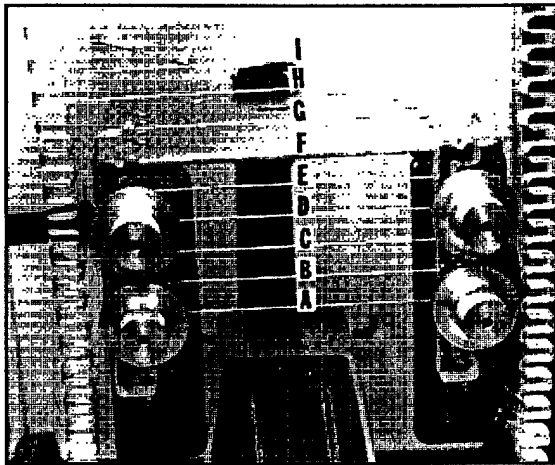

Figure 7-3

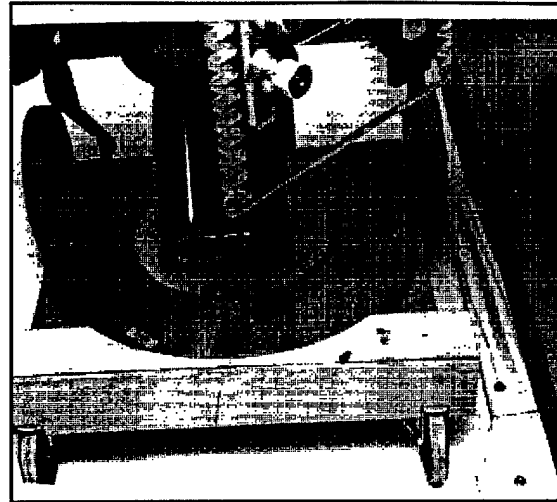

Figure 7-4

The chair was made transparent to x-rays and so were all straps, mounts and so on. The chair can be rolled into the first position after the subject is strapped in, rolled from there to the next position and then rotated for the last two positions all with the subject strapped into position and unable to move appreciably and possibly invalidate the results. Guide rails are placed on the floor to ease the process of locating the chair as it is moved (Fig.7-4).

The chair also directly participates in the x-ray process by contributing to the mathematical solution of the photogrammetric process. Several b-b's are imbedded in the chair in regions near the shoulders of the subject and along both sides of his neck (Fig.7-5).

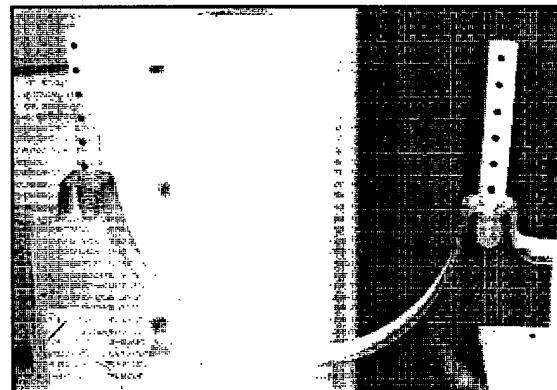

Figure 7-5

These 'pass points' can be seen on all four of the x-rays and are digitized along with the actual desired points on the subject and lend additional degrees of freedom to the solution and improve its accuracy.

The Subject.

The subject can actively participate by helping to assure that conditions for the x-rays are as close as possible to the conditions on the accelerator. A single b-b is taped to his sternum as an aide to finding the correct vertebra in the stereo x-rays (Fig.7-6).

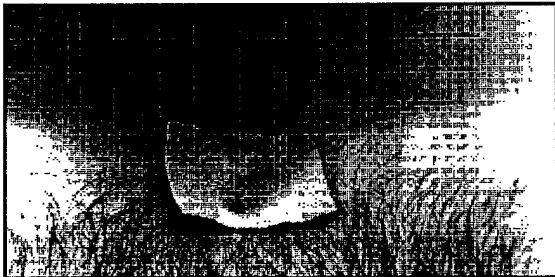

Figure 7-6

Another b-b is positioned over the T-1 vertebra in a special mount fitted individually to each subject (Fig.7-7).

This mount is strapped onto the subject and supports the T-1 instrumentation package and

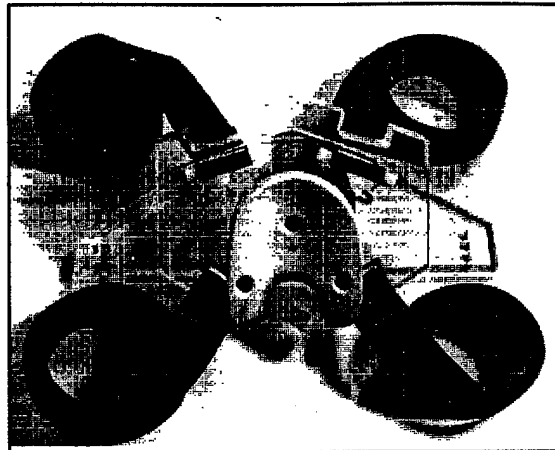

Figure 7-7

photo targets (Fig.7-8).



Figure 7-8

During the x-ray process, three b-b's in the mount are used to determine the coordinate system for the packages. Thus special effort must be made to assure that this mount is in the same position and leveled as it will be for the acceleration runs (Fig.7-9).



Figure 7-9

The subject is then strapped into the chair around the waist and groin areas (Fig.7-10).



Figure 7-10

Care is taken to insure the waist strap is horizontal (Fig.7-11).

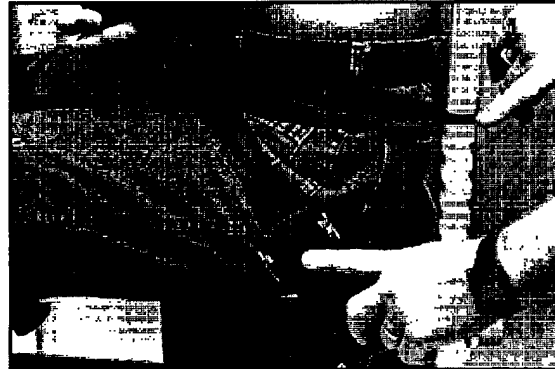

Figure 7-11

Care is also taken to insure the shoulder strap is horizontal (Fig.7-12),

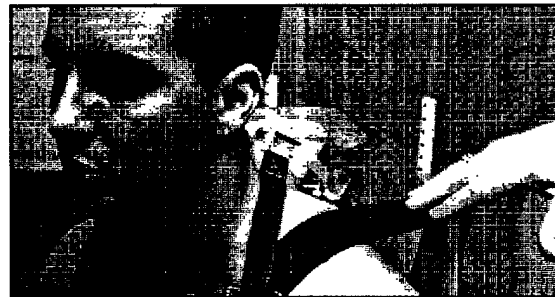

Figure 7-12

and that the shoulder strap is under the T-1 mount strap (Fig.7-13)



Figure 7-13

The knees are restrained with a strap and lead goggles are placed on the subject's face (Fig.7-14).



Figure 7-14

The X-Ray Film Carrier Frame

Additional b-b's have been placed on the edges of the acrylic plate in the frame holding the film carrier (Fig.7-15).

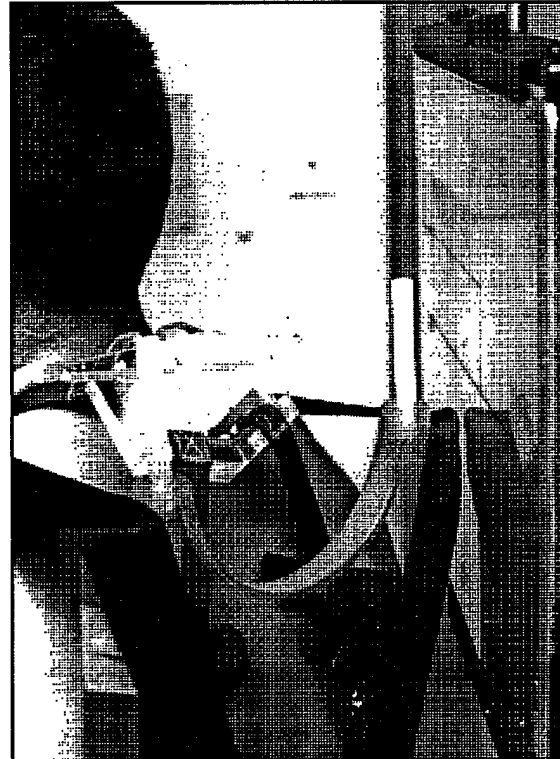

Figure 7-15

These help to compensate for film shrinkage in the pre-processor program NPREP and their locations are important in trying to get the most out of the least squares solution. Physical obstructions have been made to prevent the film from being inverted in the film carrier frame.

The X-Rays.

The X-ray machine must also be positioned fairly accurately and consistently. Floor marks determine the coarse position of the machine when a plumb bob rests above the spot (Fig.7-16).

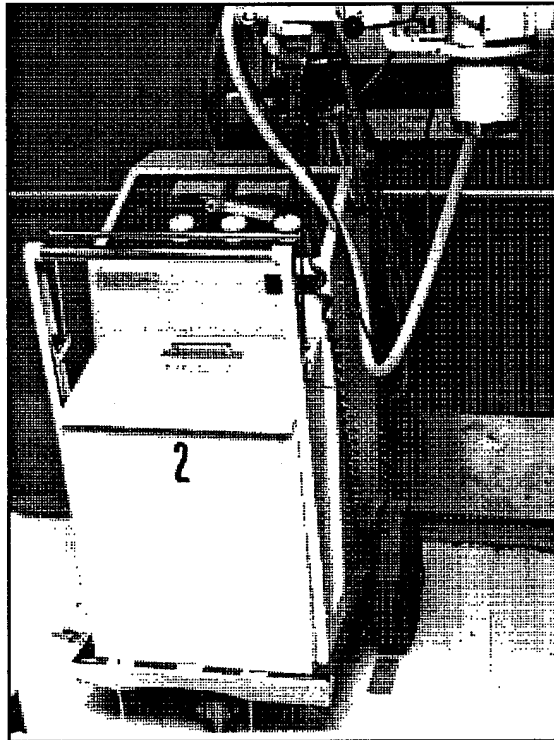

Figure 7-16

The actual operation of the x-ray machine is in the hands of competent x-ray personnel who will take the four needed x-rays—two with the left shoulder to the plate and two with the right shoulder to the plate (that is, rotated about 45° in each direction). For each of these, the subject is wheeled as far to the left (and then to the right) as possible but still assuring that the sternum b-b and those on the necks of the chair are in the picture - a total distance of only about ten centimeters (four inches) or so. The stereo pair positions when the right shoulder is to the plate are shown in the two pictures of the empty chair on the next page.

The first is called 'right shoulder, right eye' (Fig.7-17)

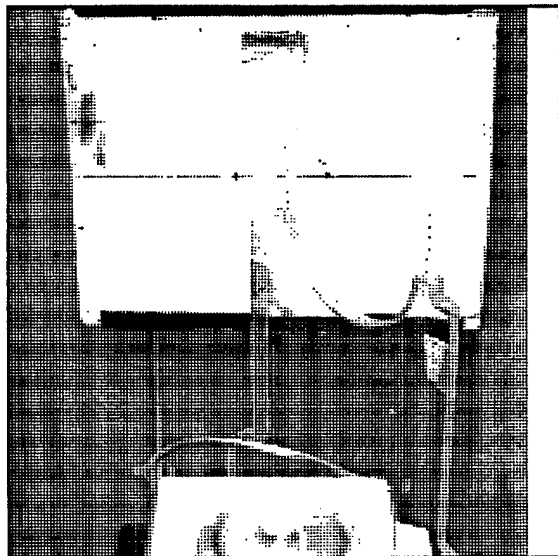

Figure 7-17

and the second one shifted slightly to the left is called 'right shoulder, left eye' (Fig.7-18).

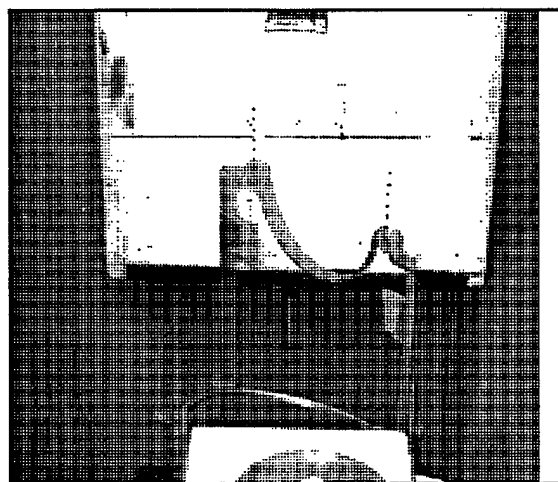

Figure 7-18

Digitizing.

After film processing, the four x-rays are digitized on the Altek digitizer using the program NPREP to prompt for the correct input points and to perform the needed processing for NGIANT. These programs will be discussed later.

Part V. Determination Of Initial Conditions.

Chapter 8. Historical Considerations.

Data acquisition until the advent of the 35mm Still Camera System has been by high speed cameras for 'photo data' and by accelerometers for 'sensor data'. The sensor data is integrated twice for translational and angular velocities and displacements. The photo data for the translational and angular positions can be differentiated twice for velocities and accelerations. The overlapping results differ. The causes can be many but some that might contribute in various degrees seem to be a lack of sophistication in the mathematical differentiation and integration packages and the minimal determination in experimental measurements. We will address this latter factor.

Two cameras view each of the mouth and T-1 mount targets, with one camera able to see

both. A target on two photos is minimally determined in space. Errors cannot be determined and a blunder unless extremely large can go undetected. The same could be said for the accelerometer package. The new rate sensor/accelerometer package can go a long way toward correcting that problem. The high-speed photo system is being eliminated as a measuring device by the new instrumentation. The only need remaining is a determination of the initial conditions-the initial position and orientation of the head and body anatomical coordinate systems.

The six-camera system can accurately fix the locations of any targets on the two mounts in the laboratory coordinate system and determine the corresponding errors. The method is discussed in the next chapter.

Chapter 9. 35mm Camera System for the Determination of Initial Conditions

The determination of initial conditions depends on locating targets in the laboratory coordinate system which are attached to the mouth and T-1 mounts. The method is the same as that used for head anthropometry. The head anthropometry needs to be done only once and objects may protrude (as out of the ears) since there is no run. For the initial conditions only those targets that can safely undergo the acceleration can be used.

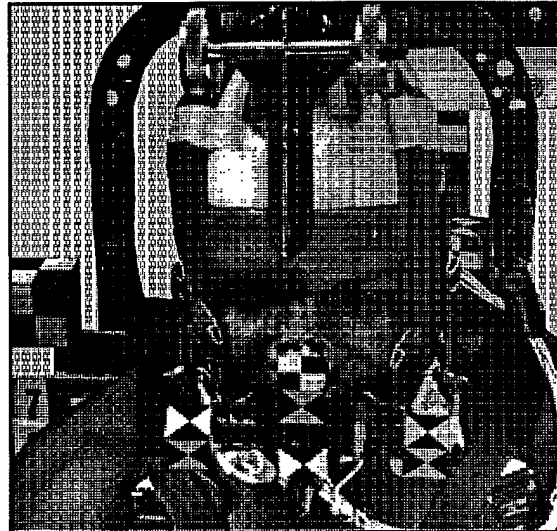

Figure 9-1

The new instrumentation package is still under development and hence this work was done for the old package/target combination.

Camera 4 has a view of the mouth targets and the control cubes, only one is seen in the close-up in Figure 9-1.

Camera 5 shows another view of the mouth mount targets and of some of the T-1 targets, which are cropped out of the close-up of Figure 9-2.



Figure 9-2

A view of the T-1 instrumentation package with its targets is shown in this close-up from camera 1. One of the control cubes is in the foreground (Fig. 9-3).

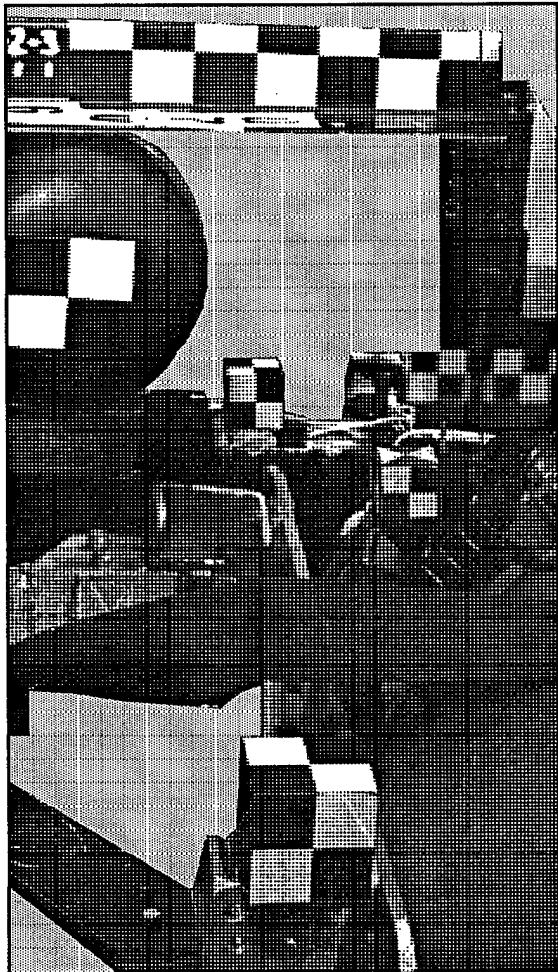

Figure 9-3

As in the other tasks, each of the target and control points on the six photos is digitized on the ALTEK digitizer using NPREP and the output of that feeds into NGIANT.

The output of this phase consists of the lab coordinates of the target points on each of the mounts.

From their surveyed positions in the mount coordinate systems, it is still necessary to determine the position and orientation of the mounts in the lab frame. The anthropometry would then determine the location of the head and body coordinate systems.

APPENDIX

NAVY GIANT SOFTWARE

FID

FID is for the determination of corner fiducials from an extrapolation of points measured (or digitized) points along each of the four edges of the image format. When presented with this problem for whatever reason, we need some vehicle to enable us to define a series of reference points (fiducials) from which to perform transformations regarding the indicated principal point (IPP) and perhaps some compensation for film shrinkage. A least squares solution is calculated for the 'fiducial corner coordinates' based on (x,y) observations of (n = 2-10) points measured on each of four edges of a polygon. A linear regression is formed to define a best-fitting equation of a line for (n) points measured on a particular format edge, each of the four edges are solved for, and the intersection of the four lines then define the four corners of the camera's format. These four corners then define the four fiducials, *de facto*. Input requires the number of points (n), left side points, upper side points, right side points, right side points. Note that at least three points on each format side (n = 3) should be used to obtain a least squares solution, and each side must have the same number of points. Output is in file FID.OUT.

FID Input data Format (File: FID.IN)

Line 1: Number of points measured on each format edge ($2 \leq n \leq 10$)

Free Format - FORMAT (*)

Line 2: x-coordinate, y-coordinate of left side (1st point),

Line 3: x-coordinate, y-coordinate of left side (2nd point),

Line 4: x-coordinate, y-coordinate of left side (3rd point),

Line 5: x-coordinate, y-coordinate of upper side (1st point), etc., etc., . . .

Free Format - FORMAT (*)

NPREP

NPREP is a PreProcessor that will transform comparator x-y coordinates to a plate-centered coordinate system, correct for both radial and tangential lens distortions as reported in the Camera Calibration Certificate. NPREP writes an output file IMG.DAT, one of the two input files for NGIANT. NPREP also writes two report files--PREP.132 in 132-column format and PREP.OUT in 80-column format.

The Photogrammetrist must specify the number of parameters to be used in the transformation from the comparator/digitizer coordinate system to the plate-centered coordinate system the fiducials are presented in as found in the camera calibration report.

A 3-parameter transformation will accommodate a change in x-coordinates and a change in y-coordinates (origin shift) as well as a rotation between the two coordinate systems that consist of the comparator (raw) coordinate system and the camera (fiducial) coordinate system. This type of transformation does not correct for any film shrinkage.

A 4-parameter transformation will accommodate a change in x-coordinates and a change in y-coordinates (origin shift) as well as a rotation between the two coordinate systems that consist of the comparator (raw) coordinate system and the camera (fiducial) coordinate system and an overall scale change (enlargement or reduction). This type of transformation performs a simple correction for film shrinkage. The 4-parameter transformation is also called a *two-dimensional linear conformal transformation* or a *two-dimensional similarity transformation*.

A 5-parameter transformation will accommodate a change in x-coordinates and a change in y-coordinates (origin shift) as well as a rotation between the two coordinate systems that consist of the comparator (raw) coordinate system and the camera (fiducial) coordinate system and a uniform scale change (enlargement or reduction) along the x-axis and a uniform scale change (enlargement or reduction) along the y-axis. The 5-parameter transformation is also called an *affine transformation*.

A 6-parameter transformation will accommodate a change in x-coordinates and a change in y-coordinates (origin shift) as well as a rotation between the two coordinate systems that consist of the comparator (raw) coordinate system and the camera (fiducial) coordinate system and a uniform scale change (enlargement or reduction) along the x-axis and a uniform scale change (enlargement or reduction) along the y-axis and a second angle representing a non-orthogonal condition of the axes (nonperpendicularity). The 6-parameter transformation is also called a *non-orthogonal affine transformation*.

An 8-parameter transformation will map a quadrilateral of one plane into a quadrilateral of another plane. Angles/shapes will not be preserved (non-conformal). The 8-parameter transformation is also called a *projective transformation*, and is the analytic representation of a photo-rectification for scale, tip, and tilt. When more than four fiducials are used, (for instance corners (4) and mid-side fiducials (4)), the RMS will give a fairly realistic estimate of true film shrinkage.

NPREP also calculates a 3-parameter 'check' transformation on the fiducials in addition to the n-parameter transformation selected - for comparison purposes only. If there is appreciable scaling (from using photo enlargements) this would not give any meaningful information. Rms deviations for these transformations are now printed for your information for both the n-parameter transformation and for the check transformation.

One has the ability to add a principal point offset to NPREP. This is commonly found in camera calibration reports. The fiducial marks are the physical points inside the camera and are adjusted at the factory to denote an Indicated Principal Point (IPP). Many aerial cameras have two IPPs; the corner fiducials' IPP and the mid-side fiducials' IPP. These principal points usually have the coordinates of (0,0) in the calibration report, the corner fiducials holding greater importance if they exist. The common offsets referred to are the Principal Point of Autocollimation (PPA) and the Principal Point of Symmetry (PPS). The Photogrammetrist also has the option to allow the program to convert input data to millimeters by giving a UNITS conversion factor.

The correction for radial lens distortion may be entered as a function. The coefficients to be entered may be obtained from DISTORT which accepts camera calibration data and performs a least squares fit to the model for radial lens distortion.

NGIANT Data Input & Program Options

TITLE

column

1-80 User's Project/Run Title (may be blank)

FORMAT (A80)

Options

column

2

0 = Camera Station Attitudes are Photo to Ground (Input/Output)

1 = Camera Station Attitudes are Ground to Photo (Input/Output)

Roll (Omega) is an angle of rotation about the x-axis of the photo. Positive Roll rotates the positive y-axis toward the positive z-axis. (Left wing up). Assume +x is direction of flight; +y is at a right angle to +x, and the positive direction is out the left wing; +z is at a right angle to the x-y plane, and the positive direction is up.

$(-180^\circ < \text{Omega} < +180^\circ)$

Pitch (Phi) is an angle of rotation about the y-axis of the photo. Positive pitch rotates the positive z-axis toward the positive x-axis. (Nose down).

$(-180^\circ < \text{Phi} < +180^\circ)$

Yaw (Kappa) is an angle of rotation about the z-axis of the photo. Positive yaw rotates the positive x-axis toward the positive y-axis.

(counterclockwise is positive). Yaw (Kappa) is approximated by a clockwise angle (photo to ground) and counterclockwise (ground to photo) measured from East to the photo (x) in the plane of the photo.

$(-180^\circ < \text{Kappa} < +180^\circ)$

2 = Terrestrial Object "Y" to Photo (Phototheodolite) (Input/Output)

Azimuth is the positive clockwise angle from the Object Space Y-axis to the Phototheodolite vertical crosshair. The rotation is clockwise about the Object Space Z-axis and rotates the positive Y-axis toward the positive X-axis.

$(0^\circ \leq \text{Azimuth} < 360^\circ)$

Elevation is the vertical angle measured about the x-axis from the Object Space XY-plane to the camera axis. The elevation is positive when the Phototheodolite (camera) axis is above the XY-plane (this is the same idea as a theodolite's inclination(+)/depression(-) angle).

$(-90^\circ < \text{Elevation} < +90^\circ)$

Swing is the clockwise angle measured about the Phototheodolite's optical axis. This is the angle obtained by the Striding Level "Par" value for the rotation of the instrument about the lens. For a generally level terrestrial photo such that the Elevation angle is approximately 0° ; this corresponds to the "tilt" of the Horizon.

$(-180^\circ < \text{Swing/Stride} < +180^\circ)$

column

- 3 0 = List Input Camera Station Parameters, 1 = do not
4 0 = List Input Plate Coordinates, 1 = do not
5 0 = List Input Object Space Control, 1 = do not
6 0 = List Output Triangulated Object Point Coordinates, 1 = do not
7 0 = Save (as a FILE) Output Triangulated Object Coords 1 = do not
File will be "OBJ.OUT"
8 0 = List Output Adjusted Camera Station Parameters, 1 = do not
9 0 = Save (as a FILE) Adjusted Camera Station Parameters, 1 = do not
File will be "CAM.OUT"
- 10 0 = Perform the COMPLETE TRIANGULATION Process
1 = Perform INTERSECTION ONLY, holding Camera Stations fixed.
- 11 1 = Perform Error Propagation for GDOP 0 = do not
<<See Option "20" for type of GDOP Output.>>
- 12 0 = Base *a posteriori* Unit Variance on completely Free Camera Parameters.
1 = Base *a posteriori* Unit Variance on Constrained Camera Parameters.
2 = Force Unit Variance to Unity (For Simulation Purposes).
- 13 0 = Sort Triangulated Object Space Points, 1 = do not
- 14 Maximum number of iterations allowed in the Least Squares Adjustment.
If this field is left blank, the default max is 4.
- 15 Any valid alphanumeric character. Any leading character which matches
this will be removed from all Name Fields.
- 18-19 Criterion ϵ for convergence of least squares adjustment. Least Squares
solution will be considered complete if the absolute change in the weighted
sum of the squares for two consecutive iterations is less than ϵ percent. If this
field is left blank, the program will assume $\epsilon = 5\%$.
- 20 0 = All *a posteriori* Positional Errors will be expressed as Error Ellipsoid
Orientation and Length (Eigenvectors & Eigenvalues in descending order
of size.) Orientation error will be expressed as Standard Deviations in DMS.

1 = All *a posteriori* Error will be expressed as Variance/Covariance Matrices
with the Object Space Points also showing the Square Roots of the Diagonal
terms under the heading "Standard Deviation".

User-Defined Default *a priori* Standard Deviations of Object Space Control
column

- 1-10 X (Object Space Units) [OPTIONAL]
- 11-20 Y (Object Space Units) [OPTIONAL]
- 21-30 Z (Object Space Units) [OPTIONAL]

FORMAT (3F10.3)

Camera Systems Identifications/Calibrated Focal Lengths
column

- 1-8 Camera System ID [Optional ONLY if there is ONLY 1 CAMERA USED.]
- 11-20 Principal Distance for the Camera System in Image Space Units with SIGN:
 - (-) working in Positive Plane (UNUSUAL)
 - (+) working in Negative Plane (USUAL with the NBDL Mann Comparator.)

FORMAT (A8, F10.3)

Repeat the above line for each of the cameras used. (Maximum = 10)

Camera System Termination Sentinel
column

- 1-8 ***** (8 Asterisks)

FORMAT (A8)

Repeat the next two lines for each camera station (photograph) used in the bundle adjustment. (Maximum = 25)

Camera Station IDs, Positions, *a priori* Standard Deviations of Positions
column

1-8	Camera Station Identification	[INPUT IS MANDATORY]
	(This must EXACTLY match a corresponding Frame ID in the IMG.DAT file)	
9-20	X Position (Object Space Units)	[INPUT IS MANDATORY]
21-32	Y Position (Object Space Units)	[INPUT IS MANDATORY]
33-44	Z Position (Object Space Units)	[INPUT IS MANDATORY]
45-54	X Position <i>a priori</i> Standard Deviation (Object Space Units)	[OPTIONAL]
55-64	Y Position <i>a priori</i> Standard Deviation (Object Space Units)	[OPTIONAL]
65-74	Z Position <i>a priori</i> Standard Deviation (Object Space Units)	[OPTIONAL]

FORMAT (A8, 3F12.3, 3F10.3)

Camera Station IDs, Attitudes, *a priori* Standard Deviations of Attitudes
column

1-8	Camera Station Identification	[INPUT IS MANDATORY]
	(This must EXACTLY match a corresponding Frame ID in the IMG.DAT file)	
9-20	Primary rotation: Omega or Azimuth (DMS)	[INPUT IS MANDATORY]
21-32	Secondary rotation: Phi or Elevation (DMS)	[INPUT IS MANDATORY]
33-44	Tertiary rotation: Kappa or Swing (DMS)	[INPUT IS MANDATORY]
45-54	Primary rotation <i>a priori</i> Standard Deviation (DMS)	[OPTIONAL]
55-64	Secondary rotation <i>a priori</i> Standard Deviation (DMS)	[OPTIONAL]
65-74	Tertiary rotation <i>a priori</i> Standard Deviation (DMS)	[OPTIONAL]

FORMAT (A8, 3F12.3, 3F10.3)

Camera Station Termination Sentinel
column

1-8 ***** (8 Asterisks)

FORMAT (A8)

Repeat the next line for each Object Space Control Point used in the bundle adjustment.
(Maximum = 499)

Object Space Control
column

1-8	Control Point Identification	[INPUT IS MANDATORY]
9-20	X Position (Object Space Units)	[INPUT IS MANDATORY]
21-32	Y Position (Object Space Units)	[INPUT IS MANDATORY]
33-44	Z Position (Object Space Units)	[INPUT IS MANDATORY]
45-54	X Position <i>a priori</i> Standard Deviation (Object Space Units)	[OPTIONAL]
55-64	Y Position <i>a priori</i> Standard Deviation (Object Space Units)	[OPTIONAL]
65-74	Z Position <i>a priori</i> Standard Deviation (Object Space Units)	[OPTIONAL]

76 Missing Component Indicator:

0 = all components are controlled;
1 = X is not to be held;
2 = Y is not to be held;
4 = Z is not to be held;
n = the sum of any of the above codes to indicate those components
which are not to be held.
(e.g., **3** is for **vertical only** control and **7** would be **no control**)

FORMAT (A8, 3F12.3, 3F10.3, 1X, 11)

Object Space Control Termination Sentinel
column

1-8 ***** (8 Asterisks)

FORMAT (A8)

Input File 2: IMG.DAT

Frame Header Record

column

- 1-8 Frame Identification
- 11-20 Principal Distance for the Camera System in Image Space Units with SIGN:
 - (-) working in Positive Plane (UNUSUAL)
 - (+) working in Negative Plane (USUAL for the NBDL comparator)If blank, the principal distance will be extracted from OPT.DAT.
- 21-30 Assigned *a priori* Standard Deviation of Image x-coordinate. [OPTIONAL]
- 31-40 Assigned *a priori* Standard Deviation of Image y-coordinate. [OPTIONAL]
(Default option for these fields is 0.010 Image Space Units.)
- 41-48 Camera System ID [Optional ONLY if there is ONLY 1 CAMERA USED.]

FORMAT (A8, 2X, 3F10.3, A8)

Repeat the next line for each image point used on this frame.

Image Point Record

column

- 1-8 Image Point Identification (Alphanumeric)
- 11-20 Image x - coordinate
- 21-30 Image y - coordinate

FORMAT (A8, 2X, 2F10.3)

Frame Termination Sentinel

column

- 1-8 ***** (8 Asterisks)

FORMAT (A8)

Frame Header Record

Image Point Records

Frame Termination Sentinel

Repeat for as many photographs as desired
up to 25 maximum. NGIANT uses only
those camera stations found in OPT.DAT

NGIANT Run Strategies and Data Editing

INTRODUCTION

Control is normally established by one of the three well known photogrammetric methods: analog, semi-analytical, or fully analytical. The fully analytical approach has developed since the 1960's when digital computers made the associated computations both possible and economical. Its primary attribute is the flexibility to accept and enforce various formats, focal lengths, and control or both camera station and ground position.

Preprocessing.

Programs such as NPREP reduce measured plate coordinates of all the points to the plate coordinate system, centered at the principal point. All known systematic errors such as film shrinkage and lens distortion. Initial estimates for camera station position and attitude are established by the user.

Triangulation.

Programs such as NGIANT accept preprocessed plate coordinates, focal length, object space control (ground control), and initial estimates of camera station position and orientation for an iterative least squares solution to solve for triangulated camera station position and orientation and triangulated object space coordinates of all pass points.

Postprocessing.

Triangulated camera station and object space coordinates are transformed to other cartesian coordinate system for further applications within NBDL.

Functions of the NGIANT Program.

NGIANT is a computer program designed to perform analytical triangulation to solve for the object coordinates of image points measured on two or more photographs. The parameters solved by this program are the object space coordinates of each of the measured image points, as stated above, and the parameters of each camera station position and orientation.

The program uses an iterative least squares technique. All parameters are treated as weighted parameters, ranging from known to unknown. Observation equations are set up as functions of the parameters. It accepts or assumes only uncorrelated observation. All parameters and observation may be weighted to reflect *a priori* knowledge of their precision. This is particularly useful in weighting object space control differentially, compensating for different sources of control of varying precision, as well as being able to utilize control with unknown components. By allowing the use of partial control points, any horizontal and vertical component is known with varying accuracies. The user may enforce known camera station positions and orientation, if they are determined by an external source such as a one-second theodolite. When these parameters can be enforced as observed quantities, the need for object space control is significantly lessened for comparable accuracy.

The program also propagates error estimates through the solution, it computes the *a posteriori* estimate of variance of unit weight and on option the variance/covariance matrix and standard deviation of each parameter of camera station position and orientation, and object space coordinates. When used with a fictitious data generator, a user may predict results before using a set of photographs, a given control pattern, or other variables. Accuracy could be predicted and additional or different configurations of control plans. Even if you don't have a fictitious data generator, this can be still be used to great advantage with a little imagination. After you have accumulated several large data sets that have been adjusted with NGIANT, you can use those data sets instead of relying on a fictitious data generator. Pruning photos off data sets, etc. we can then experiment with different control configurations by re-entering pass-points' triangulated object coordinates as control points, etc. and view the results of error propagation using the Option 12 = 2 'Force Unit Variance to Unity' for simulation purposes. The iterative least squares approach requires an initial approximation for each unknown parameter. The program requires the user to furnish initial approximations for camera position and orientation parameters, whereas, the program obtains the initial estimates of the pass point coordinates and of the missing components of the ground control points. The program has been proven to accept reasonably gross approximations for these parameters. The program expects object space coordinates to be in a space rectangular system. The rectangular coordinate system is generally required for close-range photogrammetry. The camera attitudes are parameterized in terms of roll, pitch, and yaw (omega, phi, kappa) referenced to the local vertical, and may express the relation between image and object coordinate spaces.

FOR TERRESTRIAL APPLICATIONS the Photogrammetrist must estimate all components of the Object Space Control because of the infinite variety of solutions possible.

The Photogrammetrist must give all Control components.

PROGRAM CAPABILITIES AND RESTRICTIONS

NGIANT employs a highly efficient algorithm for the formation, solution, and inversion of large linear systems of equations. This algorithm is called "Auroray" and was the original purpose for writing GIANT over twenty-five years ago - to test the "Auroray" algorithm.

It works.

Other NGIANT capabilities include the following:

Camera attitudes are parameterized in terms of roll, pitch, and yaw (omega, phi, kappa) and may express the relation between image and object coordinate spaces or vice versa. For Terrestrial applications the camera attitudes are parameterized in terms of azimuth, elevation and swing and express the relation between the image and the object coordinate space (Terrestrial to Photo).

Camera station position and attitude parameters can be constrained individually, using proper weights. Full or partial ground control can also be utilized. Partial object space control will not yield reliable results.

Photography from ten different camera systems may be triangulated simultaneously.

Data entries are grouped by photographs with the program performing all necessary cross-referencing and pass point ground coordinate estimations.

An error propagation facility exists for detailed statistical assessment of the triangulation results, this can be expressed as variance/covariance matrices or as eigenvectors and eigenvalues.

A facility exists for sorting the triangulation results.

Corrections applied to object space control point coordinates as a result of the triangulation are listed for reference and data analysis.

The internal defaults for estimated standard deviations of object space coordinates of control points can be declared on an additional record in file OPT.DAT. Provision still exists for declaring individual data items.

The Variance of Unit Weight of the triangulation residuals is listed.

Camera station position and attitude correction for each iteration are given.

Control points can be designated as unconstrained and used as test points. The residuals are listed separately and a separate *rms* computed.

Run time errors detected during the input phase, due to illegal format or data types, are printed showing the record number and contents of the offending record.

The flexibility which makes NGIANT useful also makes it difficult to establish a unique procedure for data editing and evaluation. The circumstances of any given job may necessitate a change in the procedure.

DATA EDITING

In a measured data set, such as plate coordinates, there are three general types of errors:

1. ACCIDENTAL or RANDOM errors, which the least squares technique minimizes;
2. SYSTEMATIC errors, which are not amenable to solution and have hopefully been removed by the NGIANT PreProcessor (NPREP);
3. BLUNDERS or mistakes, which are the result of incorrect observations or recording.

It is this last type of error, the blunders, which must be recognized and removed. The first two types of errors must be recognized and accounted for, but the third type must be removed for a valid solution. It occasionally becomes difficult to differentiate between large accidental errors and blunders. The "rule of thumb" is that errors exceeding the 3 sigma (standard deviations) level may be considered blunders.

* Much of this section is taken from "GIANT" by Dr. Atef Elassal (1987).

Editing Plate Coordinates using INTERSECTION-ONLY:

An INTERSECTION-ONLY computer run allows identification and removal of the following gross errors:

1. Very large errors in plate coordinates or mis-identification.
2. Incorrect combinations of photograph numbers and associated points which appear on the photograph.
3. Consistently bad photographs which either have a blunder in one or more of the camera station parameters or in the pre-processing of the plate coordinate data.
4. Differences in ground control coordinates which are proofread for differences.

In this computer run, (INTERSECTION-ONLY), one must only look for gross errors (blunders). Gross errors could be due to misidentification of points, recording errors, etc. Since this run is made with initial approximations only, large patterned residuals should be expected, especially in plate residuals. In this context, 'gross' is relative. When we get used to single-digit plate residuals as found in iterative adjustments like Relative Orientation, Absolute Orientation, etc., even a 'good' run is going to look **GROSS !**

What one looks for then, is a BREAK in the pattern.

If examination of the run shows the computed elevation of a object control point to be higher than the camera station position, one of the two most probable blunders occurred:

SIGN OF f.

The most probable blunder is the sign of the focal length being incorrect. If the plate coordinate data, as preprocessed, should be reconstructing a 35 mm photo negative, the sign of the focal length (Calibrated Focal Length or CFL), should be positive. If a photo positive 8"x 10" print has been used, the CFL should be negative (most unusual).

YAW.

The other probable cause is that the yaw angle (KAPPA) is incorrect. If this is the problem; it can be the "sense" of the Master Fiducials used for the NPREP Preprocessor run. Correct the Master Fiducials, re-run NPREP and generate a new IMG.DAT file and then re-run NGIANT.

After an INTERSECTION-ONLY run is obtained free of blunders; the option is then changed for an actual triangulation run. This is accomplished by changing the "1" to a "0" in column 10 of the second line in file OPT.DAT.

The success of an INTERSECTION-ONLY run is due to two major considerations:

1. A consistent series of station positions and attitudes need to be developed.
2. A generally consistent set of properly-observed data points (Identification & Measuring) is present.

Editing by the Study of Plate Residuals

Major blunders are easy to identify and rectify in plate coordinate data. Difficulty occurs when gross errors are eliminated and a judgment must be made on eliminating points such that the large residuals are removed. There is a human tendency to start eliminating plate coordinates with large residuals until a run is produced with all small residuals. This procedure may be carried over several runs. In this procedure, the user may inadvertently eliminate readings in an area until all readings connecting adjoining plates have been dropped. This leads to weak solutions and results in poor coordinate determinations.

Listed below are some phenomena which should occur as one approaches the best solution and which will not be obvious to the casual user. When editing, the following must be kept in mind:

Residuals will be grouped by the number of photos (rays) "seeing" a point. The residuals will appear larger for those points seen by more rays. The more rays that "see" a point, the better we hope the solution will be. This is something we should strive to accomplish in the point transfer operations, time and budgetary considerations notwithstanding. Sheer numbers of ray intersections offer no help if the quality of the point transferred is poor.

Residuals in the direction of the photo bases will tend to become zero. The error resolves itself in the weakest component. This is especially true for two-ray points. The weakest component of the computed object space position should be watched along with the plate residuals. We try to avoid two-ray points as much as possible; an over-abundance of two-ray points can lead to an indeterminate solution and is difficult to spot in close-range applications such as at NBDL.

Object Space control will tend to show a different residual grouping than for uncontrolled points. This tendency is directly related to the weighing of the plate coordinates and the control coordinates. We try to use realistic weights for all parameters, but there is a natural human tendency to weight the "known" control too tightly.

The residuals should balance for each point, *i.e.*, the positive and negative residuals should add to zero. This will be approximate, but generally true for a well-adjusted run.

There should not be any undesirable pattern of errors, *i.e.*, no systematic component. The residuals should conform with the laws of normal distribution; small errors are more likely than large errors, the error zero is most probable, and positive and negative errors are equally likely.

Editing by the Study of Camera Parameters

When editing photogrammetric computer runs with unconstrained camera stations, the camera stations are reflecting only the influence of the other data: the plate coordinates and the object space (ground) control.

On each run, the user should examine the camera positions and orientations, and ensure they are following a consistent path. Any deviation should be explained.

An excellent indicator of the quality of the run is to view the section of the Report that shows the Corrections to Camera Station Position & Attitude on an iteration-by-iteration basis. Each iteration should display progressively smaller corrections to the photographs, and each iteration should display approximately the same magnitude of correction to each photo. Furthermore, the corrections to the photo positions should reach zero before the corrections to attitude reach zero. Sometimes, when there is a convergence failure, the residuals of the plate coordinates will be so chaotic that the only way to discern a pattern of error is to look at the corrections to the Camera Station Positions & Attitudes.

Another rule of thumb to attempt to keep in mind, however, is that when residuals and/or camera station corrections are seemingly chaotic, the photogrammetrist has likely allowed a blunder to remain unresolved from a previous stage in the data editing process. Backup and re-examine earlier runs for clues. Patience and methodical analysis will rarely be unrewarded in this type of endeavor. Analytical photogrammetry is notorious for using and generating massive amounts of data that seem to numb the mind. Occasionally, problems can appear to occur from nowhere merely because the previous stage of the data editing process that was "checked" - was paged through and seen, but was not actually "read". . .
it happens.

Editing by the Study of Object Space Control

Three possibilities may cause errors:

1. Misidentification of control;
2. Poor point transfer (if any exist);
3. Bad coordinates of the point.

Remedial action is determined by the cause. Options for remedial action are:

- * Increasing the associated standard deviations to reflect the point is not as well known as others;
- * Changing the type from control to a passpoint;
- * Removing or re-reading bad plate coordinates; and
- * Re-checking and perhaps correcting the control's object space coordinates.

All coordinates of object space control points are treated as weighted unknowns. In determining the degree of freedom for the solution, direct weighted equations for unconstrained components of object space control are not counted. On the other hand, the constrained coordinate components of object space control are held in the solution to the extent of their assigned weights. The program uses its supplied values as best estimates and counts the direct weighted equations in determining the degree of freedom for the adjustment.

The following indicators should be watched carefully:

A POSTERIORI ESTIMATE OF VARIANCE OF UNIT WEIGHT

This is an important single number by which to judge a run. For a normal case, this number should approach one (1.0). The number starts out very large and as data editing and bootstrapping improve the data, it comes down to a reasonable value. Remember, this number only reflects the balance between the input standard deviations and the output residuals. If for some reason the weighing is not realistic, this number may not approach one (1.0). Watch it carefully as an indicator of overall performance along with the contributing components of the number. Final runs should normally exhibit this number to be within a $\pm 10\%$ range of Unity (0.90 - 1.10). Beyond this range, a serious bias may be present, detailed analysis and correction is normally warranted.

WEIGHTED SUM OF THE SQUARES

This number along with the changes in camera station parameters, is printed for each iteration in the report as well as on the screen. It can be used to judge how much each iteration is changing the solution and, to some extent, where the change is occurring. This number, which most often is huge at the beginning, is an estimate of the sum of the squares of the plate residuals. It is used as a convergence test, i.e., when this number changes less than a predetermined percentage the solution is stable and iterations stop. If the number increases between iterations by a large percentage, the run has diverged and we receive a "CONVERGENCE FAILURE" screen message with a "beep", usually because of bad data or weak geometry. The run is incapable of reaching a good solution. Edit the data if a pattern can be discerned; if chaotic, try re-running with fewer iterations and then editing the data.

FILM DEFORMATION TRANSFORMATIONS

Various coordinate transformations are used in the NPREProcessing (PREP) phase of the data reduction. Compensation for film deformation and conversion from the arbitrary coordinate system of the measuring equipment to the fixed reference system of the camera are both accomplished by means of coordinate transformations.

Data Requirements

Determination of the parameters of a coordinate transformation which takes points from one coordinate system into another requires that the coordinates of a specific number of points be known in both systems. The minimum number of points required depends on the type of transformation being constructed; more specifically, the minimum number of points depends on the number of parameters which have to be determined.

In the usual case, the two sets of data used to establish a transformation consist of a set of measured reference point images and a corresponding set of calibrated positions of the same points, either relative to each other or in an absolute sense. As few as two reference points can be used to establish the simplest type of transformation. There is no mathematical limit to the number of points which can be used, since a least squares solution is used to determine the transformation parameters. We have arbitrarily limited the number of fiducials to 1000 because we feel that is more than one hundred times the likely number to be used. If the user needs more, re-compile to your satisfaction.

General Form of the Transformations

The general form of the transformations is that of the projective transformation:

$$x = \frac{a_1x' + b_1y' + c_1}{dx' + ey' + 1}$$
$$y = \frac{a_2x' + b_2y' + c_2}{dx' + ey' + 1}$$

in which

x', y' are the coordinates of a point in some initial coordinate system.

x, y are the coordinates of the point after transformation to a second coordinate system.

a_1, b_1, c_1
 a_2, b_2, c_2
 d and e are the parameters of the transformation.

The transformations used for film deformation are special cases of the projective transformation. They are defined in accordance with the number of parameters used.

Three-Parameter Transformation

If the parameters of the general form of the transformation are reduced in number to three (θ, c_1, c_2) in accordance with the following relationships:

$$\begin{aligned}a_1 &= b_2 = \cos \theta \\a_2 &= -b_1 = -\sin \theta \\c_1 &= c_1 \\c_2 &= c_2 \\d &= e = 0 \quad ,\end{aligned}$$

then the Projective Equations reduce to:

$$\begin{aligned}x &= x' \cos \theta + y' \sin \theta + c_1 \\y &= -x' \sin \theta + y' \cos \theta + c_2\end{aligned}$$

This represents a three-parameter transformation which:

- (a) Translates the origin (parameters c_1 and c_2),.
- (b) Rotates the coordinate axes through an angle θ .

Four-Parameter Transformation

If the parameters of the general form of the transformation are reduced in number to four ($\theta, \lambda, c_1, c_2$) in accordance with the following relationships:

$$\begin{aligned}a_1 &= b_2 = \lambda \cos \theta \\a_2 &= -b_1 = -\lambda \sin \theta \\c_1 &= c_1 \\c_2 &= c_2 \\d &= e = 0 \quad ,\end{aligned}$$

then the Projective Equations reduce to:

$$\begin{aligned}x &= \lambda x' \cos \theta + \lambda \sin \theta y' + c_1 \\y &= -\lambda x' \sin \theta + \lambda \cos \theta y' + c_2\end{aligned}$$

This represents a four-parameter transformation which:

- (a) Translates the origin (parameters c_1 and c_2),.
- (b) Rotates the coordinate axes through an angle θ .
- (c) Provides a scale change, λ , which is uniform in all directions.

Five-Parameter Transformation

If the parameters of the general form of the transformation are reduced in number to five $(\theta, \lambda, \mu, c_1, c_2)$ in accordance with the following relationships:

$$\begin{aligned}a_1 &= \lambda \cos \theta \\b_1 &= \lambda \sin \theta \\a_2 &= -\mu \sin \theta \\b_2 &= \mu \cos \theta \\c_1 &= c_1 \\c_2 &= c_2 \\d &= e = 0\end{aligned}$$

then the Projective Equations reduce to:

$$\begin{aligned}x &= \lambda x' \cos \theta + \lambda \sin \theta y' + c_1 \\y &= -\mu x' \sin \theta + \mu \cos \theta y' + c_2\end{aligned}$$

This represents a five-parameter transformation which:

- (a) Translates the origin (parameters c_1 and c_2).
- (b) Rotates the coordinate axes through an angle θ .
- (c) Provides a scale change, λ , which is uniform along the x-axis.
- (d) Provides a scale change, μ , which is uniform along the y-axis.

Six-Parameter Transformation

If the parameters of the general form of the transformation are reduced in number to six $(\Theta, \lambda, \mu, \beta, c_1, c_2)$ in accordance with the following relationships:

$$\begin{aligned} a_1 &= \lambda \cos \theta \\ b_1 &= \mu (\sin \theta \cos \beta - \cos \theta \sin \beta) = \mu \sin (\theta - \beta) \\ a_2 &= -\lambda \sin \theta \\ b_2 &= \mu (\sin \theta \sin \beta + \cos \theta \cos \beta) = \mu \cos (\theta - \beta) \\ c_1 &= c_1 \\ c_2 &= c_2 \\ d &= e = 0 \end{aligned}$$

then the Projective Equations reduce to:

$$\begin{aligned} x &= \lambda \cos \theta x' + \mu (\sin \theta \cos \beta - \cos \theta \sin \beta) y' + c_1 \\ y &= -\lambda \sin \theta x' + \mu (\sin \theta \sin \beta + \cos \theta \cos \beta) y' + c_2 \end{aligned}$$

This represents a six-parameter transformation which:

- (a) Translates the origin (parameters c_1 and c_2).
- (b) Rotates the coordinate axes through an angle θ .
- (c) Provides a scale change, λ , which is uniform along the x-axis.
- (d) Provides a scale change, μ , which is uniform along the y-axis.
- (e) Provides a non-orthogonal deformation of the axes, β .

Eight-Parameter Transformation

If the general form of the transformation is used, retaining all parameters, we have an eight-parameter transformation. This transformation represents a projective relationship between two planes in that it maps a quadrilateral of one plane into a quadrilateral of the other plane.

Determination of Parameters

Each reference mark available contributes two equations which may be used in determining the transformation parameters. A minimum of four measured/calibrated fiducials are therefore required for the eight-parameter transformation; a minimum of three marks are required for the six-parameter or the five-parameter transformation; and a minimum of two marks are required for the four-parameter or the two-parameter transformation.

The upper limit on the order of a transformation may be specified by designating the number of available reference points. For example, two available points will allow no higher than a four-parameter transformation.

ERROR PROPAGATION

A variance-covariance matrix for each set of parameters is determined from the inverse of the normal equation. This is then multiplied by the estimate of variance of unit weight. The standard deviation for each element is the square root of the diagonal terms of that matrix.

The Variance of Unit Weight (σ_o^2) may be estimated by the equation:

$$\sigma_o^2 = \frac{\sum (v_i w_i v_i)}{(n - u)}$$

where

- v_i is the residual of the i^{th} observation
- w_i is the weight
- n is the number of observations
- u is the number of 'unknowns' or 'solvable parameters'
- $(n-u)$ is the degrees of freedom

In the photogrammetric problem the number (n) of observations is equal to the number of plate components; one for x and one for y, or two times the number of image points measured. Add to this the number of measurements for Object Space Coordinates (Control), one for each of the known components (X,Y,Z). Depending on the external source of information, camera station position (X_c, Y_c, Z_c) and orientation elements (ω, ϕ, κ) or (α, h, s) as well; they can be added to the number of observations as six times the number of camera stations. Although these are considered as solvable parameters, they can also be treated as weighted observations if sufficient information is available.

The unknowns or solvable parameters (u) are the Object Space Control positions. For each unique point in the adjustment, three unknowns are counted. Camera station position (X_c, Y_c, Z_c) and orientation elements (ω, ϕ, κ) or (α, h, s) are usually considered 'unknowns', giving rise to additional numbers of unknowns equal to six times the number of camera stations.

To summarize, let:

v = the output residual for each observation.

w = input weight which may be thought of as $1/\sigma^2$ for each observation.
(Note that 'weight' is the reciprocal of sigma squared.)

n = total number of observations.

m = $2 * \text{number of plate measurements.}$

c = 1 for each Object Space (Control) component.

s = $6 * \text{number of camera stations.}$ (Factor 6 represents the camera parameters: the position coordinates (X_c, Y_c, Z_c) and orientation elements (ω, ϕ, κ) or (α, h, s) .) These parameters are always treated as unknowns; however, depending on the external source of information, these may also be treated as weighted observations contributing to the number of direct weighted observation equations. When the weights of the direct observations are small, the camera parameters may be treated as completely free and no contribution is then made to the direct weighted observations.

p = $3 * \text{number of points } (X_G, Y_G, Z_G).$ (Note: one, two or three of these components may have also been counted as observations under 'c'.)

Again simplistically, the estimate of variance of unit weight is defined as the summation of the input weights $(1/\sigma^2)$ multiplied by the output residuals squared (v^2) . If all is perfect,

$$\frac{\sum v^2}{\sigma^2} = (n - u)$$

for all observations. This summation, when divided by the degrees of freedom (the number of observations minus the number of parameters) results in a value close to 1.00.

REPORT DOCUMENTATION PAGE*Form Approved*
OMB No. 0704-0188

Public reporting burden for this collection of information is estimated to average 1 hour per response, including the time for reviewing instructions, searching existing data sources, gathering and maintaining the data needed, and completing and reviewing the collection of information. Send comments regarding this burden estimate or any other aspect of this collection of information, including suggestions for reducing this burden, to Washington Headquarters Services, Directorate for Information Operations and Reports, 1215 Jefferson Davis Highway, Suite 1204 Arlington, VA 22202-4302, and to the Office of Management and Budget, Paperwork Reduction Project (0704-0188), Washington, DC 20503.

1. AGENCY USE ONLY (Leave Blank)**2. REPORT DATE**

December 91

3. REPORT TYPE AND DATES COVERED

Interim

4. TITLE AND SUBTITLE

Manual of Close-Range Photogrammetric Techniques for the Naval Biodynamics Laboratory

5. FUNDING NUMBERS

63216 M0097.001

6. AUTHOR(S)

GPA Associates

7. PERFORMING ORGANIZATION NAME(S) AND ADDRESS(ES)Naval Biodynamics Laboratory
P. O. Box 29407
New Orleans, LA 70189-0407**8. PERFORMING ORGANIZATION
REPORT NUMBER**

NBDL-95R008

9. SPONSORING/MONITORING AGENCY NAME(S) AND ADDRESS(ES)Naval Medical Research and Development Command
National Naval Medical Center
Building 1, Tower 12
Bethesda, MD 20889-5044**10. SPONSORING/MONITORING
AGENCY REPORT NUMBER****11. SUPPLEMENTARY NOTES****12a. DISTRIBUTION/AVAILABILITY STATEMENT**

Approved for public release; distribution is unlimited.

12b. DISTRIBUTION CODE**13. ABSTRACT (Maximum 200 words)**

This publication provides documentation to identify photogrammetric determination of initial conditions of human research volunteers, of head anthropometry, of positioning for the ship motion simulator or for site surveys. Camera calibration involves a group of observations with the objective of determining the interior orientation of a lens/camera configuration along with any systematic errors present.

14. SUBJECT TERMS

Camera Calibration, photogrammetric techniques, computer software, transformation, and GIANT.

15. NUMBER OF PAGES

60

16. PRICE CODE**17. SECURITY CLASSIFICATION
OF REPORT**

Unclassified

**18. SECURITY CLASSIFICATION
OF THIS PAGE**

Unclassified

**19. SECURITY CLASSIFICATION
OF ABSTRACT**

Unclassified

20. LIMITATION OF ABSTRACT