

Kref

NASA CR-134590
22816-6014-TU-00

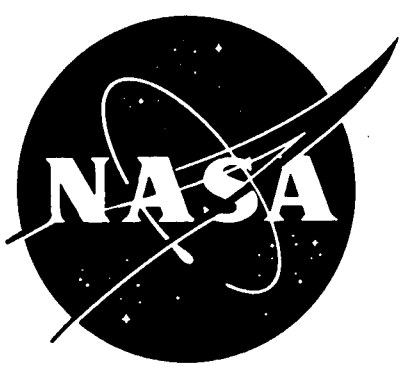

FILAMENT WINDING S-GLASS/POLYIMIDE RESIN COMPOSITE PROCESSING STUDIES

by
R.W. Vaughan and R.J. Jones



ONE SPACE PARK • REDONDO BEACH • CALIFORNIA

prepared for
NATIONAL AERONAUTICS AND SPACE ADMINISTRATION

February 1974
Contract NAS3-16760 DTIC QUALITY INSPECTED 4

NASA Lewis Research Center
Cleveland, Ohio

Tito T. Serafini, Project Manager

DISTRIBUTION STATEMENT A
Approved for public release;
Distribution Unlimited

19960215 005

PASTED
60802
20809

This report was prepared as an account of Government-sponsored work. Neither the United States, nor the National Aeronautics and Space Administration (NASA), nor any person acting on behalf of NASA:

- A.) Makes any warranty or representation, expressed or implied, with respect to the accuracy, completeness, or usefulness of the information contained in this report, or that the use of any information, apparatus, method, or process disclosed in this report may not infringe privately-owned rights; or
- B.) Assumes any liabilities with respect to the use of, or for damages resulting from the use of, any information, apparatus, method or process disclosed in this report.

As used above, "person acting on behalf of NASA" includes any employee or contractor of NASA, or employee of such contractor, to the extent that such employee or contractor of NASA or employee of such contractor prepares, disseminates, or provides access to any information pursuant to his employment or contract with NASA, or his employment with such contractor.

Requests for copies of this report should be referred to

National Aeronautics and Space Administration
Scientific and Technical Information Facility
P.O. Box 33
College Park, Md. 20740

NASA CR-134590
22816-6014-TU-00

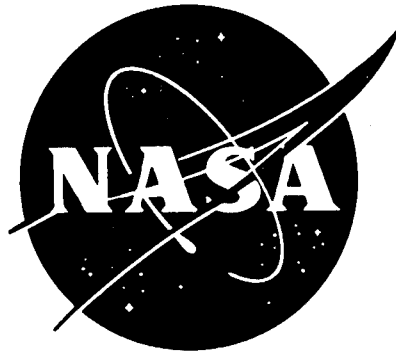

FILAMENT WINDING S-GLASS/POLYIMIDE RESIN COMPOSITE PROCESSING STUDIES

by

R.W. Vaughan and R.J. Jones

TRW
SYSTEMS GROUP

ONE SPACE PARK • REDONDO BEACH • CALIFORNIA

prepared for

NATIONAL AERONAUTICS AND SPACE ADMINISTRATION

February 1974

Contract NAS3-16760

NASA Lewis Research Center
Cleveland, Ohio

Tito T. Serafini, Project Manager

1. Report No. NASA CR-134590	2. Government Accession No.	3. Recipient's Catalog No.	
4. Title and Subtitle Filament Winding S-Glass/Polyimide Resin Composite Processing Studies		5. Report Date February 1974	6. Performing Organization Code
		8. Performing Organization Report No. 22816-6014-TU-00	
7. Author(s) R. W. Vaughan and R. J. Jones		10. Work Unit No.	
9. Performing Organization Name and Address TRW Systems 1 Space Park Redondo Beach, California 90278		11. Contract or Grant No. NAS3-16760	
		13. Type of Report and Period Covered Contractor Report	
12. Sponsoring Agency Name and Address National Aeronautics and Space Administration Washington, DC 20546		14. Sponsoring Agency Code	
		15. Supplementary Notes Project Manager, Tito T. Serafini, Materials and Structures Division, NASA-Lewis Research Center, Cleveland, Ohio	
16. Abstract This final report describes the work performed during this program to select a TRW A-type polyimide resin that would be suitable for fabrication of filament wound reinforced plastic structures. Several different formulations were evaluated after which the P105AC formulation was selected as the most promising. Procedures then were developed for preparing P105AC/S-glass roving prepreg and for fabricating filament wound structural composites. Composites were fabricated and then tested in order to obtain tensile and shear strength information. Small, closed-end cylindrical pressure vessels then were fabricated using a stainless steel liner and end fittings with a P105AC/S-glass polar wound overwrap. These pressure vessels were cured in an air circulating oven without augmented pressure. It was concluded upon completion of this study that the P105AC resin system is suitable for filament winding; that low void content, high strength composites are obtained by the filament winding process; and that augmented pressure is not required to effect the fabrication of filament wound P105AC composites.			
17. Key Words (Suggested by Author(s)) Filament Winding Filament Wound Composites Polyimide Resin P105AC/S-Glass Prepreg S-Glass Roving Pressure Vessels P105AC Resin Polyimide Composites		18. Distribution Statement Unclassified - Unlimited	
19. Security Classif. (of this report) Unclassified	20. Security Classif. (of this page) Unclassified	21. No. of Pages 64	22. Price* \$3.00

* For sale by the National Technical Information Service, Springfield, Virginia 22151

Blank Pages

FOREWORD

This document constitutes the final report for the work accomplished between 29 June 1972 and 30 September 1973 by TRW Systems Group for the National Aeronautics and Space Administration, Lewis Research Center under Contract NAS3-16760 on Filament Winding S-Glass/Polyimide Resin Composite Processing Studies.

This work was conducted under the technical direction of Dr. Tito T. Serafini of the Lewis Research Center, Cleveland, Ohio.

The Applied Chemistry Department of the Chemistry and Chemical Engineering Laboratory, Applied Technology Division, was responsible for the work performed on this program. Dr. E. A. Burns, Manager, Applied Chemistry Department provided overall program supervision and Mr. R. W. Vaughan, Head, Product Development Section was Program Manager. Dr. R. J. Jones was responsible for the preparation and characterization of resins used throughout this program. Mr. K. K. Ueda provided the major technical effort throughout the program in prepreg preparation, filament winding processing and testing.

SUMMARY

This document is the final program report describing work performed by TRW Systems for the National Aeronautics and Space Administration, Lewis Research Center under Contract NAS3-16760. The objectives of this program were: 1) To establish a processing procedure for manufacturing A-type polyimide, 12-end S-glass roving prepreg, and 2) To establish a processing procedure for filament wound pressure vessels. These objectives were accomplished by: 1) Screening several different A-type polyimide resin formulations, 2) Screening prepreg processing variations, and 3) Screening filament winding processing variations.

The first phase of the work established that the P105AC formulation was the most promising formulation for this application. Procedures then were developed for preparing P105AC/S-glass roving prepreg and for fabricating filament wound structural composites. During these studies several different mandrel materials were screened to determine their suitability for this application and it was established that tooling plaster was satisfactory. Composites were fabricated and then tested to obtain tensile and shear strength information. Values were obtained which demonstrated that the P105AC resin system provides sound structural filament wound composites without the aid of augmented pressure during processing.

The second phase of the work consisted of fabricating small, closed-end cylindrical pressure vessels using a stainless steel liner and end fittings with a P105AC/S-glass filament wound overwrap. The stainless steel liner assemblies were fabricated for TRW Systems by Structural Composites Industries, Inc., Azusa, California in accordance with NASA Lewis Research Center supplied drawings and specifications. The filament wound pressure vessels were cured in an air circulating oven without augmented pressure. After removal of the plaster mandrel from inside the pressure vessel, the finished assemblies were delivered to NASA Lewis Research Center for evaluation. A detailed process specification covering prepreg preparation and filament winding procedures then was prepared. It was concluded that the P105AC resin system is suitable for filament winding; that relatively low void content, high strength composites are obtained by the filament winding process; and that augmented pressure is not required to effect the fabrication of filament wound P105AC composites.

TABLE OF CONTENTS

	<u>Page</u>
1. INTRODUCTION	1
2. RESIN PREPARATION	3
2.1 SYNTHESIS AND EVALUATION OF P13PA'	3
2.2 SYNTHESIS AND EVALUATION OF P10PA	4
3. PREPREG DEVELOPMENT	9
3.1 ROVING PREPREG TREATING EQUIPMENT	9
3.2 EQUIPMENT CALIBRATION AND PROCESSING DEVELOPMENT	11
3.3 PREPREG EVALUATION	13
4. FILAMENT WINDING PROCESS DEVELOPMENT	17
4.1 SELECTION OF MANDREL MATERIAL	17
4.2 EVALUATION OF VARIATIONS IN FILAMENT WINDING PROCESSING	21
5. FILAMENT WOUND PRESSURE VESSEL FABRICATION	23
5.1 PRESSURE VESSEL MANUFACTURE	23
5.2 EVALUATION OF PRESSURE VESSELS	24
6. CONCLUSIONS AND RECOMMENDATIONS	27
6.1 CONCLUSIONS	27
6.2 RECOMMENDATIONS	27
7. NEW TECHNOLOGY	29
REFERENCES	31
APPENDIX A - RESIN PREPARATION PROCEDURES	33
APPENDIX B - TEST PROCEDURES	37
APPENDIX C - MATERIALS AND PROCESS SPECIFICATION FABRICATION PROCEDURES FOR FW COMPOSITE VESSELS	39

LIST OF TABLES

	<u>Page</u>
I. RESULTS OF P13PA' VARNISH AGING STUDY	5
II. RESULTS OF P10PA VARNISH AGING STUDY	7
III. PREPREG PROCESS SCREENING STUDIES	12
IV. PREPREG EVALUATION	15
V. MANDREL MATERIAL EVALUATIONS	18
VI. DETAILED EVALUATION OF WINDING TENSION VARIATIONS . .	22

LIST OF FIGURES

	<u>Page</u>
1. Storage Evaluations of P13PA'/Methanol Varnish	6
2. Storage Evaluations of P10PA Varnish	8
3. Schematic of Impregnation and Staging Equipment	10
4. Roving Prepreg Treating Equipment	10
5. Prepreg Processing Conditions	11
6. NOL Ring Winding Jig	13
7. NOL Ring Fabrication Process Screening Matrix	14
8. Effects of Winding Tension on Tensile Strength	19
9. Effects of Winding Tension on Shear Strength	20
10. Effects of Winding Tension on Resin Content	20
11. Effects of Winding Tension on Void Content	21
12. Pressure Vessel Liner Assembly	23
13. Automation Dynamics Polar Winding Machine	23
14. Polar Winding Pressure Vessel	24
15. Cured Filament Wound Assembly	24
16. Section of Filament Wound Bottle	25

1. INTRODUCTION

This Final Report presents the work accomplished by TRW Systems for the National Aeronautics and Space Administration, Lewis Research Center under Contract NAS3-16760 during the period 29 June 1972 through 30 September 1973. The objectives of the program were:

1. To establish a processing procedure for manufacturing A-type polyimide twelve-end S-glass roving prepreg.
2. To establish a processing procedure for manufacturing filament wound pressure vessels.

Structural designs for the Space Shuttle Vehicle have considered the use of filament wound construction for fabrication of both large diameter, low pressure and small diameter, high pressure vessels. Significant thermal insulation weight savings could be accrued by using filament wound main propellant tanks capable of repetitive short time (100 hours total) exposure to 389°K. Lightweight pressure vessels fabricated using present proven filament winding epoxy resin matrices have maximum upper use temperatures of 422°K on a continuous basis and short time (100 hours) duration capability of 450°K. The thermal limitations of epoxy resins preclude their use in this application. Resins capable for service in this environment include polyimides. In addition, this generic resin class has exhibited low temperature properties suitable for use with cryogenic propellants. Consequently, polyimide resins were obvious candidates for evaluation in filament wound structures for this application.

During the program performed under this contract, manufacturing processing procedures were established for producing filament wound A-type polyimide/S-glass composites. Developmental activities during this program screened three A-type polyimide resins to determine their suitability for filament winding applications. The most promising resin (P105AC) then was selected for detailed processing development studies. These studies included:

- Development of prepreg processing
- Selection of winding mandrel material
- Development of a filament winding process

Filament wound pressure vessels then were fabricated and delivered to NASA Lewis Research Center. Details of the final processing procedures were documented in a process specification and a technology transfer was completed during a project review at NASA Lewis Research Center.

This program was in five tasks. During Task I resin candidates were screening and prepreg processing methodology was developed. The selected resin system (P105AC) then was used during Task II to screen filament winding parameters including mandrel materials selection. Development of fabrication procedures for filament wound pressure vessels was performed as the Task III activity. Preparation of a detailed process specification and reporting requirements were provided as Task IV and Task V activities, respectively.

This report is divided into sections covering the following subjects:

- Resin Preparation
- Prepreg Development
- Filament Winding Process Development
- Filament Wound Pressure Vessel Fabrication

The significant conclusions reached and assessments of the results are listed, together with recommendations for activities that warrant further investigations. The information presented in the main body of this report is supplemented by appendices covering detailed descriptions of procedures used in resin preparation, filament wound composites fabrication and testing.

2. RESIN PREPARATION

Three resins were selected as candidates for evaluation during this program. These resins were:

- P10PA - 1000 FMW methyl nadic anhydride (MN)/80 methylene dianiline (MDA):20 thiodianiline (TDA)/pyromellitic dianhydride (PMDA) prepared directly from monomers to yield an amide-acid prepolymer. This system was developed previously under Contract NAS3-13489 (Reference 1). This was the first program to incorporate TDA in the prepolymer structure for providing autoclavable A-type polyimide resins.
- P13PA' - 1300 FMW MN/80MDA:20TDA/PMDA prepared from the monomethyl ester of MN and the dimethyl ester of PMDA. The use of ester monomers for A-type polyimide polymers was developed previously at NASA Lewis Research Center (Reference 2).
- P105AC - 1050 FMW nadic anhydride (NA)/80MDA:20TDA/benzophenone tetracarboxylic acid dianhydride (BTDA). This system is similar to P105A which was developed under AFML Contract F33615-70-C-1392 (Reference 3).

The P10PA and P13PA' resin varnishes were prepared by TRW Systems for this program and the P105AC resin varnish was purchased from CIBA-GEIGY Corporation. Consequently, this section describes only the P10PA and P13PA' resin synthesis and characterization activities because synthesis procedures for P105AC are held proprietary by CIBA-GEIGY Corporation.

2.1 SYNTHESIS AND EVALUATION OF P13PA'

This resin required the monomethyl ester of methyl nadic acid (ME-MNA) and the dimethyl ester of pyromellitic acid (DME-PMA). The two esters were prepared from purified starting ingredients by the reaction of methanol and either methyl nadic anhydride (MN) or pyromellitic dianhydride (PMDA) (see Appendix A). These two esters were used directly to prepare P13PA' by direct addition of the three monomers in methanol at a 50% w/w solids loading (see Appendix A). Monomers used in the preparation were analyzed to possess a $\geq 97\%$ purity level. This resin then was subjected to a 500-hour ambient room temperature (298°K) varnish aging study and changes in viscosity structure and/or solubility were monitored and documented.

The results of the storage study conducted on resin varnish composition P13PA' in methanol are presented in Table I. Some expected and unexpected observations were made during the study as commented on below.

The exposure of P13PA' monomer combination at 50% w/w solids in methanol in a container open to the atmosphere behaved much as one would expect. As the volatile methanol evaporated, some of the ingredients precipitated from solution.

The sealed container of P13PA' ingredients in methanol at the same 50% w/w solids loading gave one surprising result; a quantity of approximately 7% of the monomer ingredients precipitated during the three-week (500-hour) exposure period. This result was unexpected on the basis of previous experimentation on similar resin/monomer combinations (Reference 2). Otherwise, a gentle increase in solution viscosity, was observed during the period, amounting to a 17% increase in 500 hours. Since this phenomenon moved in the opposite direction one would expect in relationship to the precipitated material observed, a chemical reaction most probably occurred during the storage period. The tendency of both open and sealed samples of P13PA' in methanol to increase substantially in viscosity is shown in Figure 1.

2.2 SYNTHESIS AND EVALUATION OF P10PA

A sample of P10PA resin was prepared at a 40% w/w solids loading in dimethyl formamide (DMF) employing formulation methodology developed in Contract NAS3-13489 (Reference 1). This resin was diluted to 20% w/w and 25% w/w solids levels with DMF.

TABLE I.
RESULTS OF P13PA' VARNISH AGING STUDY

1. = 50% w/w open
2. = 50% w/w sealed

Period After Initiation (Hrs.)	Sample No.	Viscosity Nm ² /s @ 298°K	Results of Analyses Performed ^{a)}	
			Free Acid Titration (meq/g)	Visual Observation
0	1	54.0	2.54	Dark brown. Thin film on spindle as methanol evaporated.
	2	32.5	2.54	Dark brown. Thin film on spindle as methanol evaporated.
24	1	128.5	--	Thin film on surface of jar and ppt. occurs in bottom. Weight loss = 33.6 g.
	2	32.5	--	Small ppt. on bottom.
72	1	285.5	--	Thin film, more ppt. on bottom. Weight loss = 16.3 g. since 84 hour point.
	2	32.5	--	Slightly more ppt. (~2 to 3 g).
144	1	490	--	Weight loss = 11.2 g since 72 hour point.
	2	33.5	--	Same amount ppt.
240	1	1388	2.46	Solvent weight loss 19.5 g; large amount of ppt.
	2	34.0	2.03	Increase in ppt.
336	1	-- ^{b)}	--	Solvent almost entirely evaporated.
	2	350	--	Increase in ppt. over previous point.
408	1	-- ^{b)}	--	Solvent loss of 96% at this point.
	2	37.5	--	Increase in ppt. over previous point.
500	1	-- ^{b)}	2.26	Sample consolidated to yellow mass.
	2	38.0	1.77	10 g of ppt. at termination of test.

- a) Infrared determination was performed on each varnish at 0 hour, 240 hour and 500 hour points.
b) Viscosities could not be determined due to large amounts of precipitated resin solids.

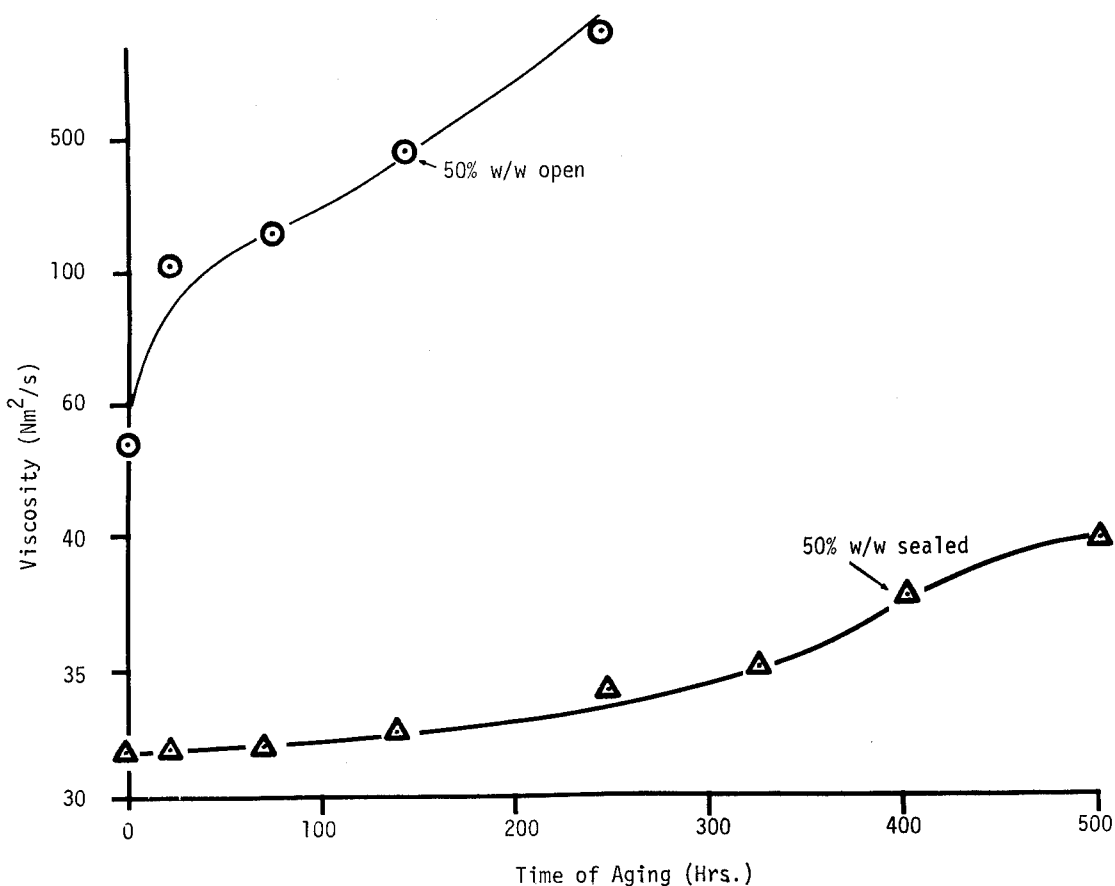

Figure 1. Storage Evaluations of P13PA'/Methanol Varnish

The results of the resin varnish aging study completed on formulation P10PA in DMF are presented in Table II. Each of the three samples tested behaved in a manner much as one would expect (*e.g.*, a continual increase in the viscosity of Sample 1 was measured as the DMF evaporated). Exposure to the atmosphere in the open container did not induce precipitation of the amide-acid polymer, even though greater than 10% of the DMF evaporated.

A small amount of precipitation occurred in the two sealed varnishes (Samples 2 and 3). Both varnishes reached equilibrium in terms of solution viscosity after or near the 168-hour (one-week) storage duration. The small amount of solid precipitation appeared (<1%) in one week and no further solid deposition was observed there after. A summary of the changes in viscosity *vs* time for all three resins in DMF is presented in Figure 2. This figure shows that P10PA varnish is sufficiently stable to meet production needs for a period of at least three weeks.

TABLE II.
RESULTS OF P10PA VARNISH AGING STUDY

1. = 25% w/w open
2. = 25% w/w sealed
3. = 20% w/w sealed

Period After Initiation (Hrs.)	Sample No.	Viscosity Nm ² /s @ 298°K	Results of Analyses Performed ^{a)}	
			Free Acid Titration (meq/g)	Visual Observation
0	1	10	1.16	Clear red color solution
	2	10	1.16	Clear red color solution
	3	6.5	0.93	Clear red color solution
72	1	13.5	--	Solvent loss 3.5 g from T ₀ , darker color
	2	9.5	--	No noticeable change
	3	6.5	--	No noticeable change
168	1	15.5	--	Solvent weight loss 14.0 g; no other change
	2	13.5	--	Small amount of ppt. (~20 mg)
	3	7.5	--	Small amount of ppt. (~20 mg)
240	1	17.5	1.02	Solvent weight loss 18.0 g; no other change
	2	8.5	0.95	No further change from previous point
	3	7.5	0.79	No further change from previous point
336	1	21.5	--	Solvent weight loss 22.7 g; no other change
	2	8.5	--	No further change
	3	7.5	--	No further change
408	1	28.5	--	Solvent weight loss 49.2 g; no further change
	2	8.5	--	No further change
	3	7.0	--	No further change
500	1	37.5	0.97	Solvent weight loss 62.2 g; dark brown color
	2	8.5	0.90	Clear red solution
	3	7.0	0.74	Clear red solution

a) Infrared determinations on each varnish were also made at 0 hour, 240 hour and 500 hour points.

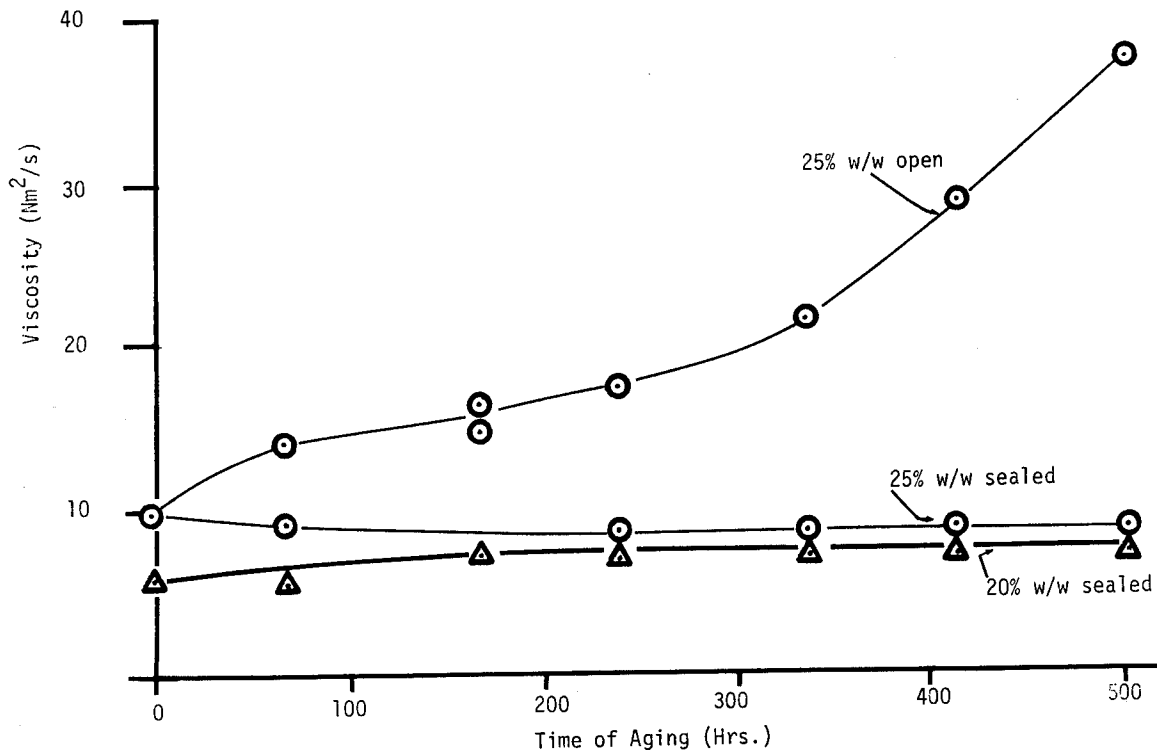

Figure 2. Storage Evaluations of P10PA Varnish

In conclusion, the most significant observation made during the storage period, was the ability of resin formulation P10PA to resist precipitation from solution at concentrations in the range of 20 to 25% solids. During Contract NAS3-13489 (Reference 1), a closely similar amide-acid composition, designated P10P, demonstrated a severe lack of stability at 40% solids and was rejected from further study due to this critical deficiency.

3. PREPREG DEVELOPMENT

One of the key objectives of this program was to establish a processing procedure for manufacturing A-type polyimide twelve-end S-glass roving prepreg. Consequently, prepreg processing studies were performed using P10PA, P105AC and P13PA' resin varnishes. These studies included set-up of the roving prepreg treating equipment, calibration of the equipment controls and definition of equipment settings for providing the required prepreg characteristics (*e.g.*, both fully imidized and also fully dried, partially imidized) but two significant problems were identified. These problems were related to loss of resin from the prepreg while rewinding after treating and also during the filament winding operation. Resin loss was caused by excessive dryness which was an effect of a) attempts to produce fully imidized prepreg with the P105AC and P10PA resin and b) use of methanol as a solvent for the P13PA' resin. Consequently, fresh prepregs were prepared containing retained solvent as a plasticizer in the prepreg in order that the prepregs remained pliable for processing. In the case of P13PA', this necessitated using DMF as the solvent instead of the previously used methanol. The resultant prepregs then were used to fabricate filament wound NOL rings which subsequently were evaluated for resin content, void and shear strength.

3.1 ROVING PREPREG TREATING EQUIPMENT

The roving prepreg treating equipment was assembled in accordance with the general schematic shown in Figure 3. A photograph of this equipment (see Figure 4) shows details of the present design used throughout this program.

This equipment consists of a roving let-off stand complete with a simple tensioning device (see upper left-hand corner of photograph). The roving proceeds from the let-off spool down into a resin bath, in which resin pick-up is controlled by a standard 'dip and flow' method. After impregnation, the roving proceeds through two vertical drying towers (up and down) which are heated by forced hot air flow. Staging of the dried prepreg then is performed in an electrically heated horizontal staging oven (tube furnace with forced air flow). Forced air flow through the drying towers and staging chamber is controlled individually and

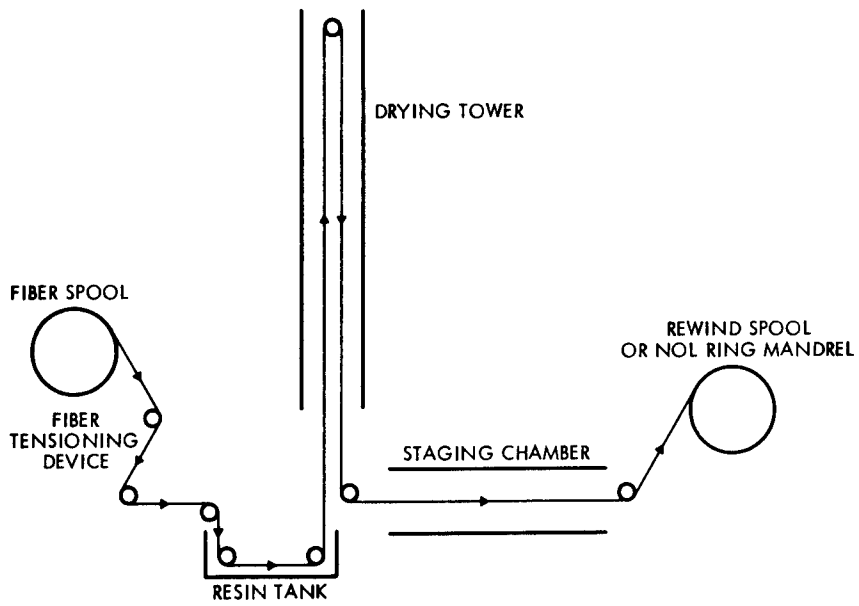

Figure 3. Schematic of Impregnation and Staging Equipment

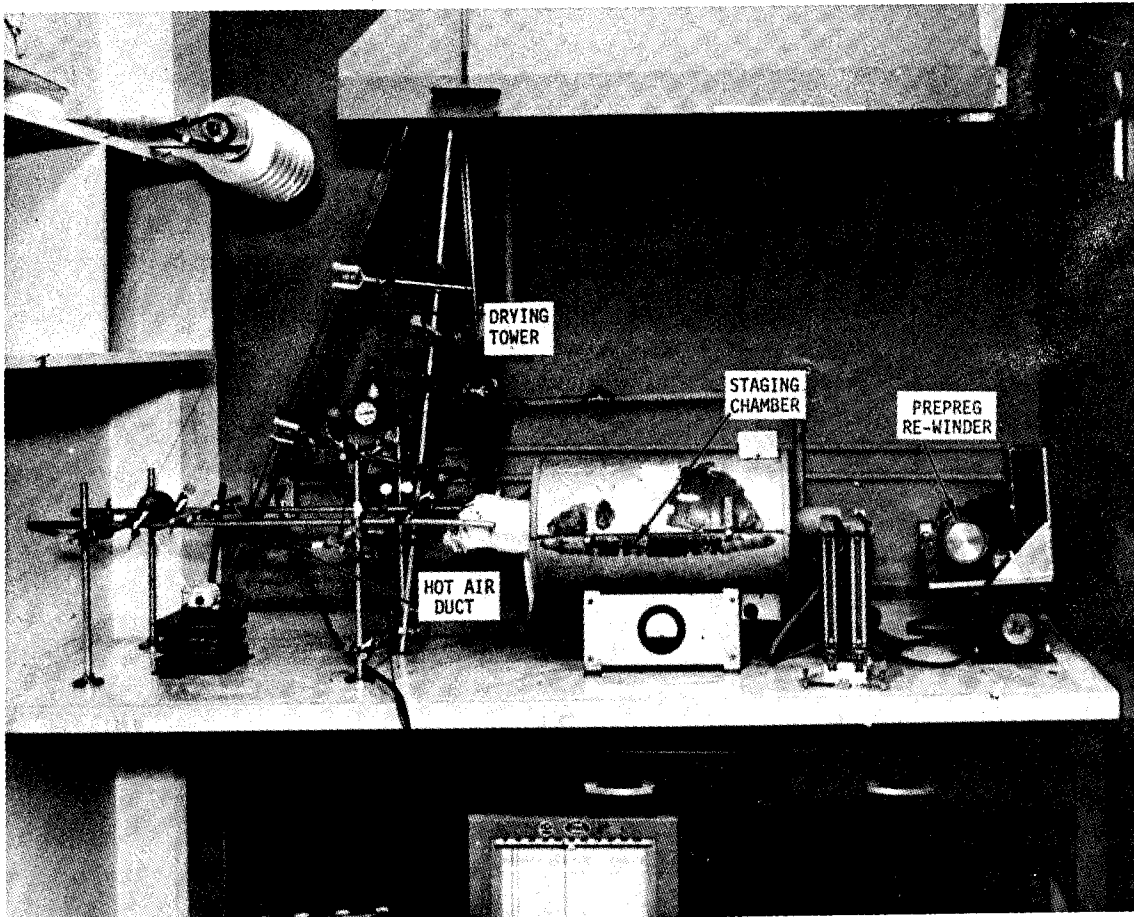

Figure 4. Roving Prepreg Treating Equipment

metered by air flow meters (see lower right hand of photograph). Rewinding of the prepreg then is performed on an Automation Dynamics Wave Winder which is equipped with a variable speed electric motor for controlling treating rates. Thermocouples are located inside both drying towers and inside the staging chamber.

3.2 EQUIPMENT CALIBRATION AND PROCESSING DEVELOPMENT

Studies were commenced using the P10PA and P13PA' resin varnishes for screening processing treating variables. As this work proceeded, it became necessary to modify the treating equipment in order to maintain constant drying and treating conditions throughout a run. These modifications included redesign of the hot air duct to the drying towers and of the forced air system (the equipment shown in Figure 4 includes all of the above modifications). Summarized data obtained during this equipment evolutionary period are provided in Table III and show processing conditions *vs* measured prepreg characteristics. Based on these results the processing conditions defined in Figure 5 were selected for providing tacky and tack-free prepreg from each resin system.

	Tacky			Tack-Free		
	P105AC	P10PA	P13PA'	P105AC	P10PA	P13PA'
Treating Rate, m/min.	2.0	2.0	2.0	1.2	1.2	1.2
Chamber Temp., °K	580	580	580	580	580	580
Resin Solids, % w/w	40	40	30	40	40	30
Air Flow, l/sec.	0.264	0.132	0.264	0.264	0.132	0.264

Figure 5. Prepreg Processing Conditions

TABLE III.
PREPREG PROCESS SCREENING STUDIES

Run No.	Treating Rate Meters/Min.	Forced Air Flow Liters/ Sec.	Staging Chamber Temp. °K	Coating Resin		Measured Prepreg Properties	
				Type	Solids % w/w	Resin Content % w/w	Volatile Content % w/w
1	2.7	(a)	620	P10PA	40	28	5.8
2	3.0	(a)	630	P10PA	40	31	10.0
3	3.4	(a)	630	P10PA	40	32	11.9
4	1.2	(a)	445	P10PA	40	22	4.7
5	2.0	(a)	455	P10PA	40	27	6.3
6	2.7	(a)	465	P10PA	40	30	8.7
7	2.7	(a)	465	P10PA	40	30	7.7
8	2.0	(a)	580	P10PA	40	25	2.0
9	1.2	0.264	620	P10PA	40	24	3.4
10	2.7	0.264	620	P10PA	40	32	13.0
11	2.0	0.132	620	P10PA	40	27	6.8
12	1.2	0.066	620	P10PA	40	24	2.2
13	2.7	0.066	620	P10PA	40	25	6.5
14	1.2	0.264	480	P10PA	40	24	4.1
15	2.7	0.264	480	P10PA	40	31	7.6
16	2.0	0.132	480	P10PA	40	30	12.2
17	1.2	0.066	480	P10PA	40	29	7.9
18	2.0	0.264	550	P10PA	40	29	5.2
19	1.2	0.132	550	P10PA	40	27	7.5
20	2.7	0.132	550	P10PA	40	30	12.3
21	2.0	0.066	550	P10PA	40	30	13.0
22	2.0	0.264	480	P13PA ^a	50	33	5.5
23	1.2	0.264	550	P13PA ^a	50	38	2.2
24	2.7	0.264	550	P13PA ^a	50	25	3.5
25	1.2	0.132	480	P13PA ^a	50	29	2.6
26	2.7	0.132	480	P13PA ^a	50	31	6.6
27	2.0	0.132	550	P13PA ^a	50	37	6.6
28	2.0	0.066	480	P13PA ^a	50	40	7.4
29	1.2	0.066	550	P13PA ^a	50	34	2.4
30	2.7	0.066	550	P13PA ^a	50	37	7.0
31	3.4	0.132	580	P105AC	25	25.4	6.8
32	3.4	0.132	580	P105AC	25	24.0	7.4
33	3.4	0.132	560	P105AC	25	27.9	9.1
34	4.1	0.132	560	P13PA ^a _b	30	17.9	5.8
35	4.1	0.132	580	P13PA ^a _b	30	12.8	3.1
36	4.1	0.132	580	P13PA ^a _b	30	12.8	3.1
37	3.4	0.132	560	P10PA	25	16.2	7.9
38	3.4	0.132	580	P10PA	25	25.3	6.6
39	3.4	0.132	580	P10PA	25	25.3	6.6

(a) Not metered

(b) DMF Solutions

3.3 PREPREG EVALUATION

Glass fiber, 12-end roving (Owens Corning S-904), was impregnated with the two amide-acid/DMF varnishes (P105AC and P10PA) and the P13PA' monomer/DMF solution using the equipment described above. Treating conditions were adjusted to provide prepregs from all three resin systems that possessed minimum and maximum retained solvent levels concomitant with processability. Processing conditions are defined in Figure 5 and prepreg properties are summarized in Table III.

NOL rings then were filament wound from the prepregs described previously using a steel winding jig as shown in Figure 6. Compensating Tension Controls, Inc., Model 800C012 device was used for controlling filament tension and a hot air flow was impinged onto the prepreg as it contacted the winding jig surface in order to obtain resin flow during the winding operation. The winding speed was maintained at a constant 316 mm per second (~ 41 RPM) for all winding tensions. A fractional factorial experimental matrix as shown in Figure 7 was utilized to screen prepreg conditions and winding tensions with all three resin systems.

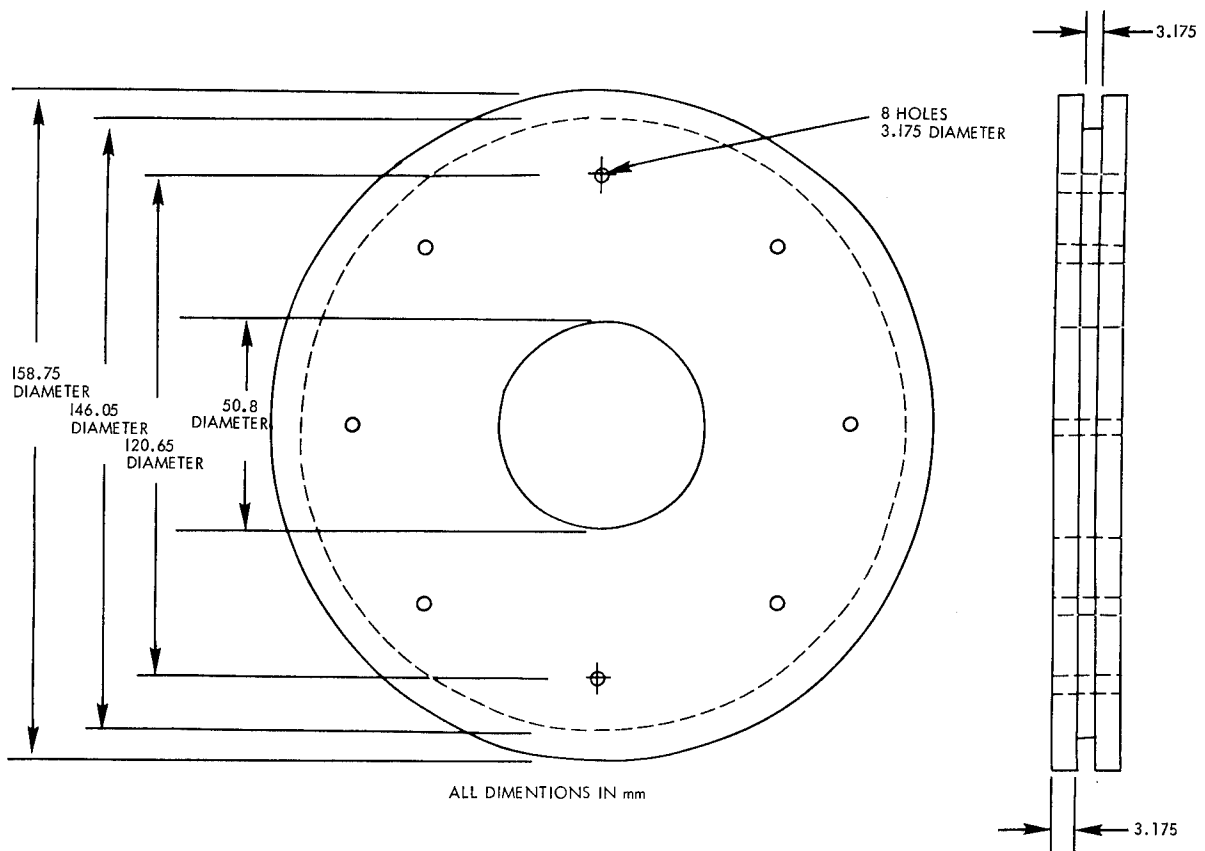

Figure 6. NOL Ring Winding Jig

Resin System and Prepreg Condition						Winding Tension, Kg/end
P13PA'		P105A		P10PA		
Tacky	Tack-Free	Tacky	Tack-Free	Tacky	Tack-Free	
X			X	X		0.2
	X	X			X	0.4
	X	X			X	0.6

Figure 7. NOL Ring Fabrication Process Screening Matrix

After winding, the NOL rings were cured on the winding jig in an air circulating oven at 505°K for two hours. They then were cooled down to room temperature and removed from the jig.

Prepreg evaluation consisted of defining the interrelationships between prepreg resin and volatile content together with the filament winding tension upon NOL ring shear strength, resin and void content. The results of these evaluations are shown in Table IV and indicate that P105AC resin is the most promising system for filament winding applications. This conclusion is based upon the following observations:

- P105AC resin provided the three overall highest shear strength values obtained during this study.
- At equivalent resin contents (21.3% w/w for P10PA using 0.6 Kg/end winding tension and 24.8% w/w for P105AC using 0.2 Kg/end winding tension) the P105AC resin provided a higher shear strength than P10PA.
- At equivalent resin contents (14.6% w/w for P13PA' using 0.6 Kg/end winding tension and 13.8% w/w for P10PA using 0.2 Kg/end winding tension) the P10PA resin provided a higher shear strength than P13PA'.

TABLE IV.
PREPREG EVALUATION

Filament Winding Tension Kg/End	Resin System	Prepreg Condition	Prepreg Properties			NOL Ring Composite Properties		
			Volatile Content % w/w	Resin Content % w/w	Resin Flow % w/w ^{a)}	Resin Content % w/w	Void Content % w/w	Shear Strength at R. I. MN/m ²
0.2	P10PA	Tacky	7.9	16.2	18.2	13.8	8.7	33
0.4	P10PA	Tack-free	6.6	25.3	39.5	15.3	7.2	40
0.6	P10PA	Tack-free	6.6	25.3	15.8	21.3	5.9	27
0.2	P105AC	Tack-free	6.8	25.4	2.3	24.8	7.3	52
0.4	P105AC	Tacky	7.4	24.0	2.4	19.1	8.9	57
0.6	P105AC	Tacky	9.1	27.9	37.6	17.4	6.9	53
0.2	P13PA'	Tacky	5.8	17.9	33.5	11.9	10.5	28
0.4	P13PA'	Tack-free	3.1	12.8	13.3	11.1	8.4	19
0.6	P13PA	Tack-free	5.6	18.8	23.4	14.6	6.2	22

(a)Based upon percentage of available resin lost during molding

$$\text{Calculated: } F = \frac{R_p - R_c}{R_p} \times 100$$

Where: F = Resin Flow %, w/w
 R_p = Resin Content of Prepreg %, w/w
 R_c = Resin content of NOL Ring %, w/w

Also, it was decided that the tacky P105AC/S904 prepreg was preferable to the tack-free prepreg because:

- The tacky material was easier to handle, and
- Resin content control was maintained because there was no resin loss due to flaking.

4. FILAMENT WINDING PROCESS DEVELOPMENT

Development of a filament winding process for P105AC/S904 glass fiber 12-end roving prepreg consisted of defining the following two key processing requirements:

- Type of mandrel material
- Winding tension and rate

Definition of a basic filament winding process was necessary in order to meet the second key objective of this program, *i.e.* to establish a processing procedure for manufacturing polar wound pressure vessels.

4.1 SELECTION OF MANDREL MATERIAL

Three materials were selected as candidates for evaluation during this program. These materials and the manufacturing procedures used to manufacture mandrels from them are defined below:

- Plaster Mandrel - Hollow plaster mandrels were cast from U.S. Gypsum Company Ultra-Cal 30 using a split master mold with a 146 mm inside diameter. Plaster mixing proportions for the hollow mandrels were:

Ultra-Cal 30	100 pbw
Tap Water	50 pbw
- Paraplast Mandrel - Hollow mandrels were cast in the same split plaster mold as above using Rezolin Inc. Paraplast 55. This material is white and has a melting temperature in the range of 540°K to 570°K.
- Copper Mandrel - A 146 mm diameter mandrel was machined from a hollow billet of copper alloy containing 85% w/w copper, 7% w/w tin, 6% w/w lead and 2% w/w zinc. This mandrel was machined with a small draft angle to facilitate removal of cured filament wound cylinders. It was necessary to provide the draft angle because the coefficients of thermal expansion for the copper alloy and filament wound polyimide/glass composite are similar.

These Paraplast, plaster and copper mandrels were preheated in an air circulating oven to 340°K prior to installing in a lathe. Aluminum alloy foil (0.6 mm thick) was wrapped around the Paraplast and plaster mandrels and then MS-136 fluorocarbon mold release was applied to the aluminum alloy foil and directly to the copper mandrel. Prepreg was wound onto the mandrels to provide one band per 3 linear millimeters at a winding rate of 305 linear millimeter per second. A hot air flow was impinged onto the roving as it contacted the mandrel so that both the prepreg and the mandrel surface were heated to 340°K at the time of contact. Winding tension was adjusted to 0.2, 0.4 or 0.6 Kg/end as required in accordance with Table V. Fifteen layers of prepreg were wound onto each mandrel and then the cylinders were cured in an air circulating oven. This was accomplished by placing the filament winding while still on the mandrel into a preheated oven at 585°K. The cylinders on the copper mandrel were cured for 2 hours, and those on the other two mandrels were cured for 3 hours because of the longer heat-up necessary with these mandrel materials. Upon removal from the cure oven, the Paraplast mandrel was distorted and unsuitable for further use. The plaster mandrels were brittle and subsequently broke during removal of the filament wound cylinders.

TABLE V.
MANDREL MATERIAL EVALUATIONS

Property	Winding Tension, Kg/end	Mandrel Material ^{a)}		
		Plaster	Paraplast	Copper
Tensile Strength, MN/m ²	0.2	1030	b	800
	0.4	880	b	1040
	0.6	1260	b	1180
Shear Strength, GN/m ²	0.2	28	b	32
	0.4	32	b	40
	0.6	29	b	44
Resin Content, % w/w	0.2	20	b	18
	0.4	15	b	17
	0.6	14	b	12
Void Content, % v/v	0.2	6	b	9
	0.4	5	b	12
	0.6	4	b	5

a) Properties of S-glass/PI05A filament wound cylinders fabricated on the noted mandrel materials.

b) Cylinders were unsuitable for test.

The cylinders that were wound and cured on the Paraplast mandrel delaminated during machining and consequently there were no test data generated for cylinders fabricated on this type of mandrel. Test result values for cylinders fabricated on the remaining two types of mandrels were similar to each other (see Table V), very scattered, and showed no significant trends to distinguish them (see Figures 8, 9, 10 and 11). Consequently, a cost analysis was performed in order to establish which type of mandrel material was most cost effective for use in this program. Upon completion of this analyses, it was decided that in order to meet the objectives of the program, a plaster material would be most suitable. This decision was based on the fact that the most economical route for obtaining stainless steel liners was to purchase them from Structural Composites Industries, Inc. which would necessitate casting the mandrels inside the completed liners.

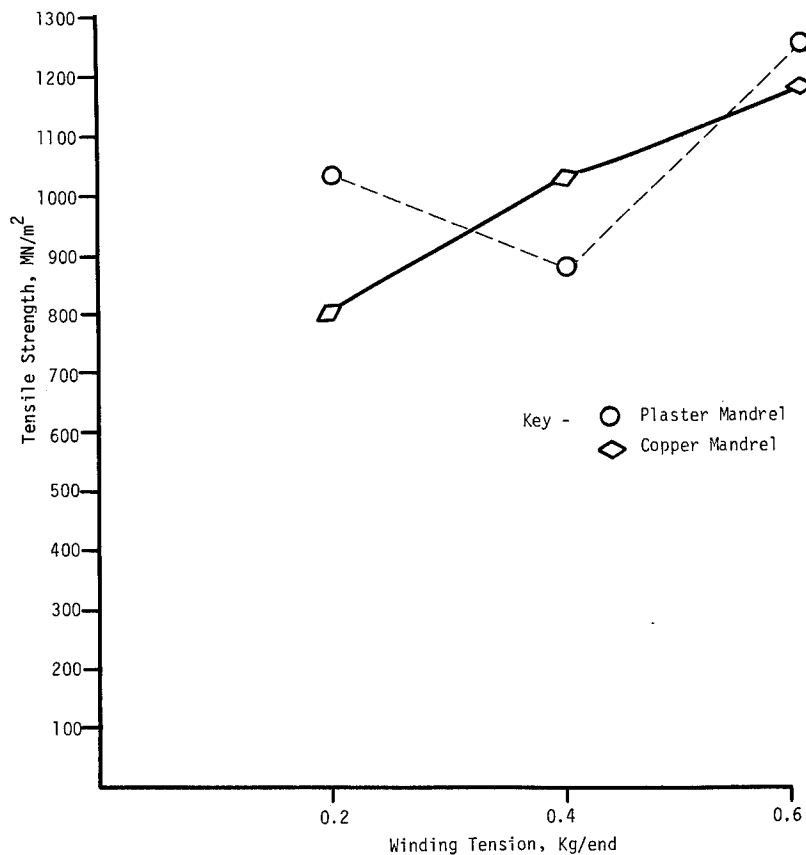

Figure 8. Effects of Winding Tension on Tensile Strength

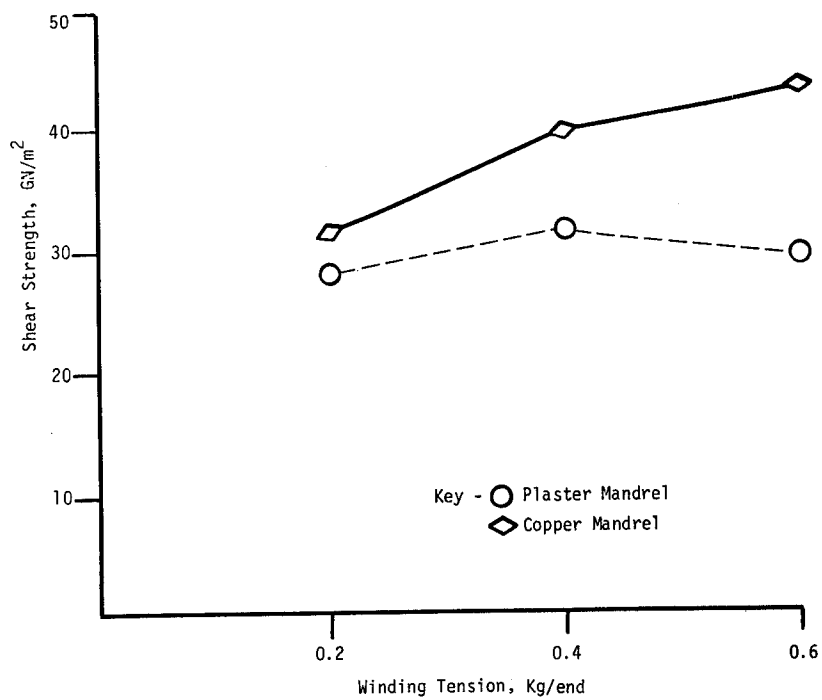

Figure 9. Effects of Winding Tension on Shear Strength

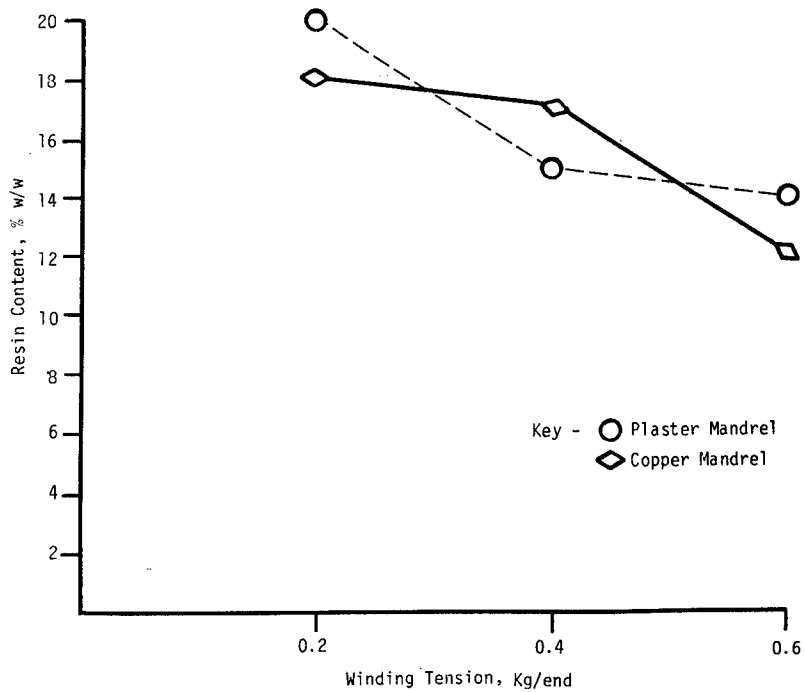

Figure 10. Effects of Winding Tension on Resin Content

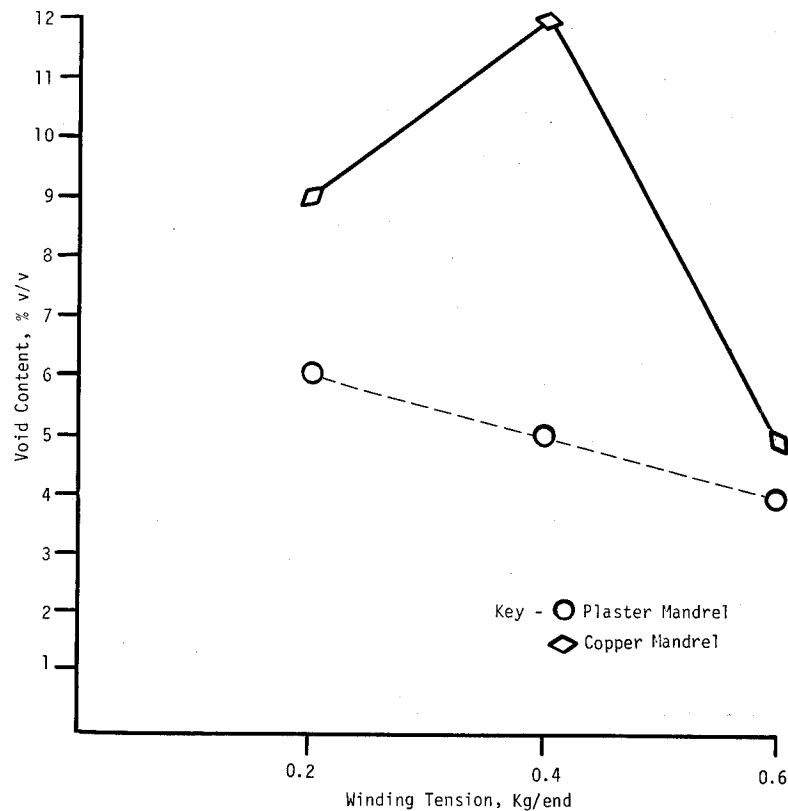

Figure 11. Effects of Winding Tension on Void Content

4.2 EVALUATION OF VARIATIONS IN FILAMENT WINDING PROCESSING

Previous process studies (see Sections 3.3 and 4.1) had provided preliminary information related to the effects of process variations upon filament wound composite properties. However, because the results obtained during these studies had produced wide data scatter, it was necessary to perform a detailed processing study in order to establish a procedure for fabricating filament wound pressure vessels.

Plaster mandrels were prepared in accordance with the procedure described in Section 4.1. Cylinders were fabricated consisting of all circumferentially wound reinforcements spaced at one band per 3 linear millimeters. Winding rate was held constant at 305 linear millimeters per second and the hot air flow impinging onto the prepreg was held at a constant temperature of 340°K. Winding tension was adjusted to 0.3 or 0.4 Kg/end as required in accordance with Table VI. Fifteen layers of prepreg were wound onto each mandrel and then one layer of perforated

Teflon glass fabric tape plus three plies of dry 12-end glass roving were wound over the prepreg. The cylinders then were cured for 2 hours at 589°K in an air circulating oven. The resultant cylinders were machined into tensile test rings and tested in a hydraulic NOL ring test machine in accordance with Appendix B-1. Results from these tests (see Table VI) indicated tension of 0.4 Kg/end was the most suitable for circumferential windings.

TABLE VI.
DETAILED EVALUATION OF WINDING TENSION VARIATIONS

Winding Tension, Kg/End	Tensile Strength, MN/m ²	Resin Content, % w/w	Density, g/cm ³	Void Content, % v/v
0.3	1040	17	1.95	10
0.4	1160	17	2.02	6

5. FILAMENT WOUND PRESSURE VESSEL FABRICATION

Filament wound pressure vessels were fabricated consisting of stainless steel liners and end fittings with P105AC/S904 polar and circumferential wound structural cases. One of the vessels then was dissected and evaluated for resin content and liner adhesion. The remaining four vessels were delivered to NASA Lewis Research Center for future pressure burst tests.

5.1. PRESSURE VESSEL MANUFACTURE

Small stainless steel liners and end fittings were fabricated for the filament winding process development studies. These liner assemblies were manufactured by Structural Composites Industries, Inc. (SCI) in accordance with SCI Drawing 1269288. The liner assemblies (see Figure 12) were filled with wash-out plaster and dried in readiness for winding.

Polar winding studies during this program were performed on an Automation Dynamics Winding Machine Model PW-8 (see Figure 13). It was established that a winding rate of 305 linear millimeters per second and a winding tension of 0.4 Kg/end provided good polar wound composites. Consequently, these conditions were used to fabricate test pressure vessels.

Fabrication of the test units commenced by first cleaning the stainless steel liner assemblies and then coating them with TRW P4 polyimide adhesive primer (Reference 6). The primer coating was baked for 45 minutes at 436°K

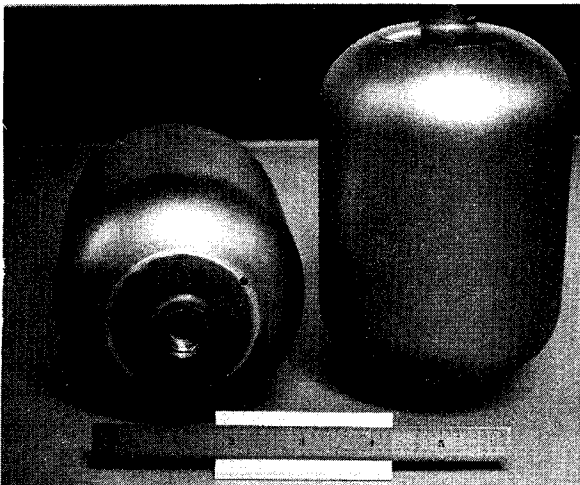

Figure 12. Pressure Vessel Liner Assembly

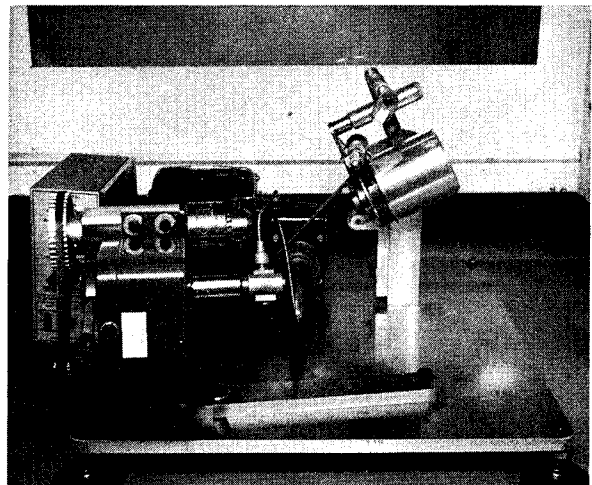

Figure 13. Automation Dynamics Polar Winding Machine

in an air circulating oven after which the liner assemblies were mounted in the winding machine.

Polar winding of the pressure vessels then commenced using P105AC/S904 prepreg. Hot air was impinged onto the prepreg to maintain the resin at $\sim 340^{\circ}\text{K}$ while winding under a tension of 0.4 Kg/end. Two layers of polar windings, *i.e.*, one revolution of in-plane windings were applied. The polar wound assemblies (see Figure 14) were removed from this machine and mounted in a circumferential winding machine.

Three layers of circumferential windings were wound over the cylindrical section of the vessel. Winding conditions were the same as those used for the polar windings. After securing the prepreg ends, the filament wound assemblies were cured in an air circulating oven for 2 hours at 589°K . Excess resin was removed from the exterior of the cured pressure vessels (see Figure 15) and the plaster core was removed from the interior of the vessels using a high pressure stream of hot water.

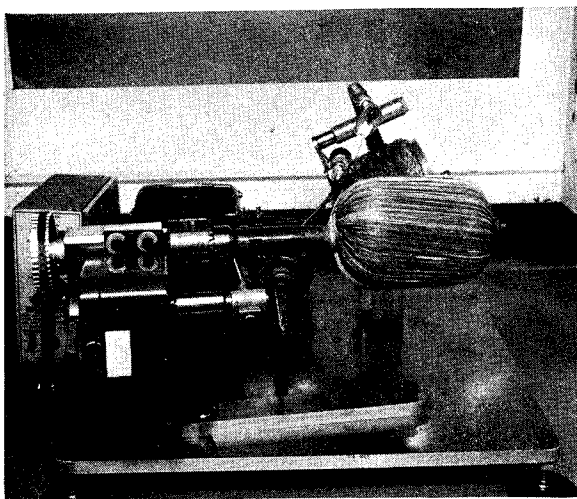

Figure 14. Polar Winding Pressure Vessel



Figure 15. Cured Filament Wound Assembly

5.2 EVALUATION OF PRESSURE VESSELS

One of the cured filament wound pressure vessels was sectioned (see Figure 16) and examined. The P105AC/S904 composite appeared to be well consolidated and had good adhesion to the stainless steel liner. Resin content of the cured composites was determined using a section cut out of the cylindrical area of the bottle. The resin content value obtained was 32% w/w and the density of the composite in this area was 1.63. These

values differ from those shown in Table VI because the sectioned pressure vessel specimens were cut from polar and circumferentially wound composite whereas the specimens used for generating Table VI data were cut from circumferentially wound NOL rings. Four filament wound pressure vessels were delivered to NASA Lewis Research Center for testing.

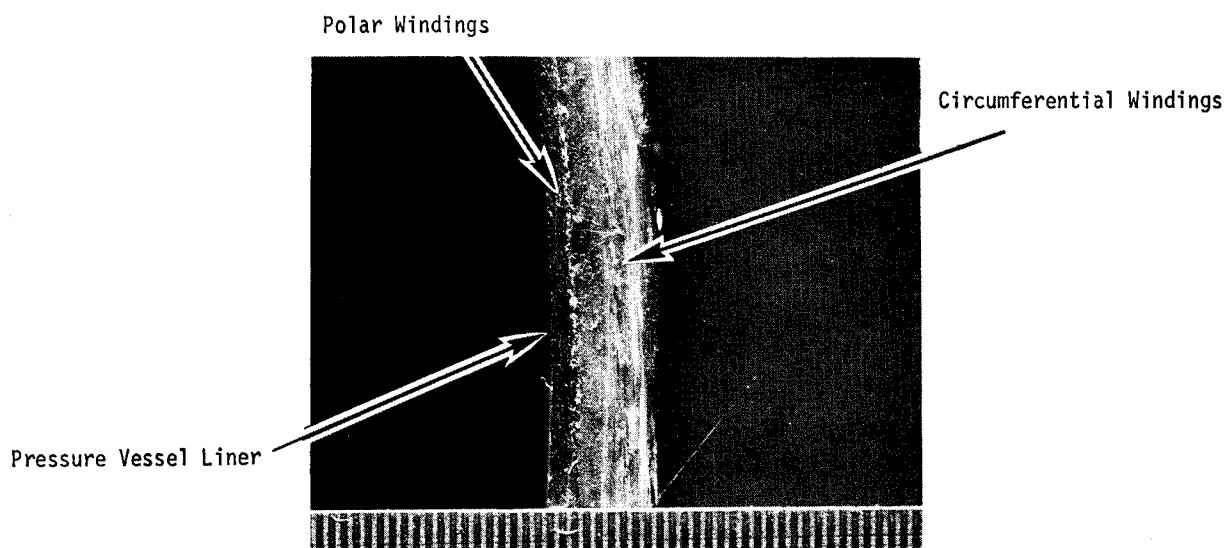

Figure 16. Section of Filament Wound Bottle

6. CONCLUSIONS AND RECOMMENDATIONS

Summarized below are the conclusions reached during this effort to select a polyimide resin for fabrication of filament wound reinforced plastic structures. Based on these findings, recommendations are given for further material improvement and evaluation studies.

6.1 CONCLUSIONS

It was concluded from the results of this effort that the P105AC TRW A-type polyimide resin is suitable for manufacture of filament wound, glass fiber reinforced, composite structures. The features of the P105AC A-type polyimide resin for filament winding applications are as follows:

- Relatively low void content, high strength composites are obtained by the filament winding process.
- Augmented pressure during cure is not required to effect the fabrication of filament wound P105AC composites.
- Structural composites suitable for short-time use at service temperatures up to 589°K are provided by filament winding P105AC prepregs.
- The P105AC resin provides glass fiber roving prepregs that are suitable for use with conventional filament winding equipment.
- Conventional mandrel materials, *i.e.*, tool casting plaster, is suitable for processing P105AC filament wound composites.

6.2 RECOMMENDATIONS

During the technical efforts of this program, the key technical area of concern was the high temperature (589°K) required to effect complete cure of the P105AC resin. This high temperature cure requirement had direct implication on the selection of both mandrel and liner materials. Consequently, it is recommended that other high service temperature resin systems that cure at lower temperatures be evaluated for manufacture of filament wound composite structures. Resin systems recommended for

evaluation include the poly(Diels Alder) (PDA) polyimide resins developed by TRW Systems under Contract NAS3-15834. These resins cure at temperatures below 480°K during similar cure periods to the P105AC resin. Recommended development and evaluation studies for manufacture of filament wound PDA resin composites include:

- Tailoring of PDA resin formulations to suit filament winding processing.
- Development of PDA prepreg processing procedures.
- Development of PDA prepreg filament winding procedures.
- Evaluation of PDA filament wound composites and structures.

7. NEW TECHNOLOGY

Methods of preparing filament wound, glass fiber reinforced, polyimide resin structural composites were developed that possessed low void content and high strength. These methods were described in a New Technology Disclosure (Docket Number 74-003) submitted to the TRW Patent Office entitled "Process For Forming P105AC A-type Polyimide Resin, Filament Wound Composite Structures".

REFERENCES

1. R. J. Jones, R. W. Vaughan and E. A. Burns, "Thermally Stable Laminating Resins", NASA CR-72984 dated 7 February 1972.
2. T. T. Serafini, P. Delvigs and G. R. Lightsey, "Thermally Stable Polyimides From Solutions of Monomeric Reactants", NASA TN D-6611, dated January 1972.
3. R. W. Vaughan and R. J. Jones, "Processable High Temperature Laminating Resins", AFML TR-71-19, dated March 1972.
4. V. Milani, F. R. Barnet, P. W. Erikson, "NOL Hydraulic Ring Tensile Tester", NAVORD Report 6735, May 1960.
5. ASTM Standards, Apparent Horizontal Shear Strength of Reinforced Plastics by Short Beam Method, ASTM D2344.
6. R. W. Vaughan and R. J. Jones, "The Development of Autoclave Processable Thermally Stable Adhesives for Titanium Alloy and Graphite Composite Structures", NASA CR-112003, dated December 1971.

APPENDIX A.
RESIN PREPARATION PROCEDURES

Pertinent methodology employed for preparation of P13PA' precursors as well as P10PA and P13PA' resin varnishes are presented below. A discussion of all the procedures is presented in Section 2.

A.1 Monomer Synthesis

P13PA requires the monomethyl ester of methyl nadic acid (ME-MNA) and the dimethyl ester of pyromellitic acid (DME-PMA). The preparation of these two monomers is described below.

A.1.1 Synthesis of the Monomethyl Ester of Methyl Nadic Acid (ME-MNA)-

The ME-MNA monomer was prepared by the following procedure:

In a 1000-cm³ round bottomed flask, fitted with a reflux condenser drying tube, and a magnetic stirrer was placed 250 g (1.4 mole) of freshly distilled nadic methyl anhydride (purity level by titration = 98%). To the anhydride was added 260 cm³ of reagent grade methanol and the solution was heated at reflux for six hours. At the end of the time period, a colorless liquid ester remained as the product; complete conversion to ester was indicated to the detectability of infrared (IR) analysis.

No attempt was made to purify the ester product due to the initial high purity of the starting ingredients. This product was used directly to prepare a monomeric varnish formulation as described in Section A.2.2.

A.1.2 Synthesis of the Dimethyl Ester of Pyromellitic Acid (DE-PMA)-

The DE-PMA monomer was prepared by the following procedure:

In a 2000-cm³ round bottomed flask, fitted with magnetic stirrer and a reflux condenser with a drying tube attached, was placed a solution of 500 g (2.30 moles) of PMDA (purity level = 98%) dissolved in 600 cm³ of methanol. The mixture was refluxed for five hours, then unreacted methanol was stripped off under

vacuum. Upon cooling to room temperature a solid precipitate formed which was collected by filtration. The crude product was dissolved in 3000 cm³ methyl ethyl ketone (MEK) and allowed to recrystallize. The recrystalline product was collected by filtration, then dried at 373°K (100°C) under vacuum overnight to give 300 g (70%) of the desired dimethyl ester of PMDA; m.p. 511°K-513°K (238°-240°C), IR analysis showed no detectable unreacted anhydride.

This product was employed directly to prepare the monomeric resin varnish described in Section A.2.2.

A.2 Varnish Synthesis

The P10PA and P13PA' resin varnishes were prepared from the ingredients synthesized as described in Section A.1 and/or monomers purified to ≥97% purity by the normal methodology described in Contract NAS3-13489. These procedures are described below in detail.

A.2.1 Procedure for Preparing P10PA - The P10PA resin varnish for the aging studies (See Section 2.2.3) was prepared at a 40% w/w solids loading in dimethyl formamide (DMF) using the standard methodology as follows:

A 3000-cm³ round bottomed flask equipped with a mechanical stirrer and a thermometer was purged with nitrogen, then 281.7 g (1.43 moles) of recrystallized MDA (purity level = 99%) and 73.6 g (0.34 mole) of recrystallized TDA (purity level = 97%) in 600 cm³ DMF was added. The temperature was adjusted to 293°K-298°K (20°C-25°C), then 280 g (1.53 moles) of MN (purity level = 98%) in 200 cm³ DMF was added with stirring over a period of 15 minutes. After this addition, the reaction mixture was allowed to stir under nitrogen for 20 minutes at 293°K, then 213 g (0.99 mole) PMDA (purity level = 98%) slurried in 548 cm³ DMF, was added carefully over a period of 30 minutes, during which time the reaction

temperature in the flask was controlled between 293°K-298°K by an external cooling bath. After the addition, the mixture was allowed to stir at 298°K for two hours. The resulting 40% w/w solids loaded varnish product from this procedure was light brown in color. The varnish was divided into two portions and each was diluted with additional DMF to give a 25% w/w solids formulation (viscosity = 0.010 Nm²/s) and a 20% w/w solids formulation (viscosity = 0.0065 Nm²/s).

A.2.2 Procedure for Preparing P13PA' - The procedure below describes the methodology used to prepare P13PA' monomeric varnish formulation for the aging study (See 2.2.3).

In a 2000-cm³ three-neck round-bottom flask, fitted with mechanical stirrer, thermometer, and nitrogen inlet tube, was added 140 g (0.6 mole) of ME-MNA and 350 cm³ of solvent (absolute methanol or DMF). Stirring was initiated and 158.4 g (0.80 mole) of recrystallized MDA (purity level = 99%) was added slowly while maintaining the temperature below 298°K (25°C) with an external ice-bath. This step was followed by the addition of 43.2 g (0.20 mole) of TDA (purity level = 97%). This mixture was allowed to stir under a nitrogen purge for 20 minutes, then 188 g (0.67 mole) of DE-PMA slurried in 100 cm³ of solvent was added slowly. The resulting 50% w/w solids loaded product was stirred for two hours at 298°K then the contents of the flask was poured into two 400-cm³ wide-mouth jars to be employed in an aging study. One jar was sealed under nitrogen and the other allowed to remain open. The viscosity at this point was 0.032 Nm²/s at 298°K.

APPENDIX B. TEST PROCEDURES

Details of test procedures used during the evaluation of filament wound composites are provided herein.

B.1 TENSILE TEST PROCEDURE

NOL test rings were machined from the cylinders to 2.5mm thick by 6.4mm wide and then placed singly into a hydraulic NOL ring test machine (Reference 4). The NOL test ring and obturator ring were moistened with hydraulic fluid and then the Teflon coated spring steel shims were inserted between them. The sealing surface of the cover plate was moistened with hydraulic fluid and then loosely bolted down over the assembled rings. After the pressure chamber had been purged of air with hydraulic fluid, the inner bolts were torqued to 164 joules and the outer bolts to 328 joules. The NOL test rings then were loaded hydraulically to failure and the hydraulic pressure at failure was recorded. Tensile strength of the rings was calculated in accordance with Reference 4 using the formula:

$$T_u = \frac{P_u D_i}{2d}$$

Where: T_u = Tensile strength, MN/m^2

P_u = Hydraulic pressure at failure, MN/m^2

D_i = Inside diameter of NOL ring, m

d = NOL ring thickness, m

B.2 SHEAR TEST PROCEDURE

Short beam shear specimens were machined from NOL rings (see Section 3.3) to a length equal to six times the rings thickness ($6d$). These then were loaded in flexure at a rate of 1.2mm/minute using a single point center loading and a span of $4d$ (Reference 5). Shear strength was calculated in accordance with Reference 5 using the formula:

$$S_u = \frac{3L}{4bd}$$

Where: S_u = Shear strength, n/m^2
L = Load at failure, newtons
b = NOL ring width, m
d = NOL ring thickness, m

APPENDIX C.

MATERIALS AND PROCESS SPECIFICATION
FABRICATION PROCEDURES FOR
FW COMPOSITE VESSELS

C.1 SCOPE

This document establishes the materials and the method of fabrication to be employed for the manufacture of FW composite vessels using P105AC polyimide resin. Quality Assurance procedures for the control and acceptance of raw materials, details and assemblies are defined herein.

C.2 APPLICABLE DOCUMENTS

Specifications

SCI Specification
9141-5*

Liner Assembly, Pressure Vessel,
4.0-inch diameter by 6.5-inch
long, Type 321 Stainless Steel.

Procedures

NAVORD Report 6735

NOL Hydraulic Ring Tensile Tester

ASTM D2344**

Apparent Horizontal Shear Strength
of Reinforced Plastics by Short
Beam Method.

SCI Test Procedure
1269288*

Helium Leak Test Procedure for
Liner Assembly, Pressure Vessel 4.0-
inch diameter by 6.5-inch long,
Type 321 Stainless Steel.

Reports

SCI*

Design Analysis of 4-inch diameter
by 6-inch long, 321 SS-Lined Glass
Filament Wound/Polyimide Resin Com-
posite Pressure Vessel

Drawings

SCI Drawing 1269288*

Pressure Vessel

SCI Drawing 1269289*

Liner Assembly

*SCI - Structural Composites Industries, Inc., 6344 North Irwindale Avenue,
Azusa, California 91702

**ASTM- American Society for Testing and Materials, 1916 Race St.,
Philadelphia, Pa. 19103

C.3 MATERIAL

C.3.1 Direct Materials

P105AC Resin -	Polyimide Resin, amide-imide solids 40% w/w in DMF. CIBA-GEIGY Corporation, Ardsley, New York.
DMF Solvent -	Dimethyl formamide, Baker Reagent Grade
S904 12-end Glass Roving -	S904 Positive End Roving, 12-ends, G Filament, S-Glass, High Temperature Epoxy Compatible Finish. Owens-Corning Fiberglass Corp., 717 Fifth Avenue, New York, New York 10022.
P4 Adhesive Primer -	Polyimide Adhesive Primer, CIBA-GEIGY Corporation, Ardsley, New York.

C.3.2 Indirect Materials

MEK -	Methyl ethyl ketone, Electrical Grade
Acetone -	Acetone, Electrical Grade

C.4 REQUIREMENTS

C.4.1 Equipment and Facilities Requirements

C.4.1.1 Prepreg Manufacturing Facility - The prepreg manufacturing facility shall be capable of precisely metering resin onto the reinforcement in order that the resin solids content of the impregnated material is maintained within $\pm 1\%$ w/w of the specified nominal resin content. Heating chambers shall be capable of precisely thermally treating the impregnated material in order that the resin melt and flow characteristics meet the processing requirements. The facility shall be adequately vented to exhaust DMF and other volatile matter in accordance with OSHA directives.

C.4.1.2 Filament Winding Facility - The filament winding facility shall be capable of precisely controlling winding tension, pattern, temperature and rate. The facility shall be adequately vented to exhaust DMF and other volatile matter in accordance with OSHA directives.

C.4.1.3 Ovens - Ovens for curing laminates and bonded assemblies shall be the air circulating type with temperature recording devices and temperature controls capable of maintaining specified temperatures.

C.4.2 Fabrication Requirements

C.4.2.1 Pressure Vessel Liner Assembly - The pressure vessel liner assemblies shall be fabricated in accordance with SCI Specification 9141-5 and SCI drawing 1269289. All assemblies shall be inspected in accordance with SCI Document, "Helium Leak Test Procedure, Liner Assembly, Pressure Vessel 4.0-inch Diameter by 6.5-inch Long, Type 321 Stainless Steel".

C.4.2.2 Surface Preparation of Liner Assembly - The pressure vessel liner assemblies shall be degreased and primed with P4 polyimide adhesive primer. Adhesive primer shall be thermally treated in an air circulating oven for 15 minutes at 408°K plus 5 minutes at 450°K.

C.4.2.3 P105AC/S904 Prepreg - Prepreg shall be prepared from P105AC polyimide resin and S904 12-end glass roving and shall meet the following requirements:

Resin Solids Content, % w/w 24 \pm 2

Volatile Matter Content, % w/w 9 \pm 2

Resin Flow, % w/w 4 \pm 1

C.4.2.4 FW P105AC/S904 Composite Pressure Vessel - The filament wound P105AC/S904 composite pressure vessels shall consist of two layers of polar wound prepreg and three layers of circumferentially wound prepreg. Winding and curing conditions shall be:

Winding Tension, Kg/end -	0.4
Winding Rate, mm/sec -	305
Winding Temperature, °K -	340
Cure Temperature, °K -	589
Cure Time, hours -	2

C.5 PROCEDURE

C.5.1 Preparation of Liner Assemblies

Liner Assemblies in accordance with SCI drawing 1269289 shall be filled with tooling plaster (U.S. Gypsum Co., Ultra-Cal 30 or equivalent) to provide adequate support to the stainless steel skins during winding. A suitable hole shall be left through the center of the plaster to permit passage of the winding machine arbor. The stainless steel skins shall be degreased with MEK and then a coating of P4 polyimide adhesive primer shall be applied. The primer shall be thermally treated in an air circulating oven for 45 minutes at 436°K.

C.5.2 Preparation of P105AC/S904 Prepreg

Owens-Corning S904 12-end glass roving shall be installed on a suitable let-off device to permit even unwinding of the glass roving. The roving shall pass through a bath of P105AC resin at 40% w/w resin solids and around suitable metering bars to control the resin content. Impregnated roving then shall be passed through a forced air heating chamber maintained at 355°K for a total residency of 2 minutes. After this the prepreg shall pass through a second forced air heating chamber maintained at 589°K for a total residency of 30 seconds. The resultant partially dried/imidized prepreg shall be rewound on a spool suitable for mounting on a winding machine tensioning device.

C.5.3 Filament Winding Procedure

The liner assemblies prepared in accordance with C.5.1 shall be mounted in a suitable filament winding machine. Prepreg P105AC/S904 prepared in accordance with C.5.2 shall be wound in-plane around the liner assemblies at a winding tension of 0.4 Kg/end. A hot air flow shall maintain the prepreg at 340°K during the winding operation. Adjacent rovings shall lay shoulder to shoulder with 0.04mm maximum gap or overlap. Each pressure vessel shall consist of two layers of in-plane windings, *i.e.* one revolution of in-plane windings. The cylindrical portion of the pressure vessels then shall be wound with three layers of circumferential windings. After securing the prepreg ends, the filament wound assembly shall be cured for 2 hours at 589°K in an air circulating oven. Excess resin and overwrap tape shall be removed from the exterior of the cured pressure vessels and the plaster core shall be removed from the interior of the pressure vessels. A high pressure stream of hot water has been found suitable for this operation.

DISTRIBUTION LIST

	<u>Copies</u>
National Aeronautics and Space Administration	
Lewis Research Center	
21000 Brookpark Road	
Cleveland, Ohio 44135	
ATTN: Contracting Officer, MS 500-313	1
Technical Report Control Office, MS 5-5	1
Technology Utilization Office, MS 3-16	1
AFSC Liaison Office, MS 4-1	2
Library, MS 60-3	2
Office of Reliability & Quality Assurance, MS 500-111	1
G. M. Ault, MS 3-13	1
R. H. Kemp, MS 49-1	1
Polymer Section, MS 49-1	15
S. S. Manson, MS 49-1	1
N. T. Musial, MS 500-313	1
National Aeronautics and Space Administration	
Washington, D. C. 20546	
ATTN: B. G. Achhammer, RW	3
NASA Scientific and Technical Information Facility	
Acquisitions Branch	
P.O. Box 33	
College Park, Md.	
	10
National Aeronautics and Space Administration	
Ames Research Center	
Moffett Field, California 94035	
ATTN: Library	1
National Aeronautics and Space Administration	
Flight Research Center	
P.O. Box 273	
Edwards, California 93523	
ATTN: Library	1
National Aeronautics and Space Administration	
Goddard Space Flight Center	
Greenbelt, Maryland 20771	
ATTN: Library	1

	<u>Copies</u>
National Aeronautics and Space Administration John F. Kennedy Space Center Kennedy Space Center, Florida 32899	
ATTN: Library	1
National Aeronautics and Space Administration Langley Research Center Langley Station Hampton, Virginia 23365	
ATTN: V. L. Bell	1
National Aeronautics and Space Administration L. B. Johnson Space Center Houston, Texas 77001	
ATTN: Library	1
Code EP	1
National Aeronautics and Space Administration George C. Marshall Space Flight Center Huntsville, Alabama 35812	
ATTN: J. Curry	1
J. Stuckey	1
Jet Propulsion Laboratory 4800 Oak Grove Drive Pasadena, California 91103	
ATTN: Library	1
Office of the Director of Defense Research and Engineering Washington, D. C. 20301	
ATTN: H. W. Schulz, Office of Assistant Director (Chem. Technology)	1
Defense Documentation Center Cameron Station Alexandria, Virginia 22314	
	1

	<u>Copies</u>
Research and Technology Division Bolling Air Force Base Washington, D. C. 20332 ATTN: RTNP	1
Air Force Materials Laboratory Wright-Patterson Air Force Base Dayton, Ohio 45433 ATTN: T. J. Reinhart MXE/J. Rhodehame	1 1
Office of Aerospace Research (RROSP) 1400 Wilson Boulevard Arlington, Virginia 22209 ATTN: Major Thomas Tomaskovic	1
Arnold Engineering Development Center Air Force Systems Command Tullahoma, Tennessee 37389 ATTN: AEOIM	1
Air Force Systems Command Andrews Air Force Base Washington, D. C. 20332 ATTN: SCLT/Capt. S. W. Bowen	1
Air Force Rocket Propulsion Laboratory Edwards, California 93523 ATTN: RPM	1
Air Force Flight Test Center Edwards Air Force Base, California 93523 ATTN: FTAT-2	1
Air Force Office of Scientific Research Washington, D. C. 20333 ATTN: SREP/J. F. Masi	1

	<u>Copies</u>
Commanding Officer U. S. Army Research Office (Durham) Box GM, Duke Station Durham, North Carolina 27706	1
U. S. Army Missile Command Redstone Scientific Information Center Redstone Arsenal, Alabama 35808 ATTN: Chief, Document Section	1
Bureau of Naval Weapons Department of the Navy Washington, D. C. 20360 ATTN: DLI-3	1
Commander U. S. Naval Missile Center Point Mugu, California 93041 ATTN: Technical Library	1
Commander U. S. Naval Ordnance Test Station China Lake, California 93557 ATTN: Code 45	1
Director (Code 6180) U. S. Naval Research Laboratory Washington, D. C. 20390 ATTN: H. W. Carhart	1
Picatinny Arsenal Dover, New Jersey ATTN: SMUPA-VP3	1
Aeroprojects, Inc. 310 East Rosedale Avenue West Chester, Pennsylvania 19380 ATTN: C. D. McKinney	1

	<u>Copies</u>
Chemical Propulsion Information Agency Applied Physics Laboratory 8621 Georgia Avenue Silver Spring, Maryland 20910	1
University of Denver Denver Research Institute P. O. Box 10127 Denver, Colorado 80210	
ATTN: Security Office	1
General Dynamics/Astronautics P. O. Box 1128 San Diego, California 92112	
ATTN: Library & Information Services (128-00)	1
Hughes Aircraft Company Culver City, California	
ATTN: N. Bilow	1
Institute for Defense Analyses 400 Army-Navy Drive Arlington, Virginia 22202	
ATTN: Classified Library	1
ITT Research Institute Technology Center Chicago, Illinois 60616	
ATTN: C. K. Hersh, Chemistry Division	1
Lockheed Missiles & Space Company Propulsion Engineering Division (D.55-11) 1111 Lockheed Way Sunnyvale, California 94087	1
Lockheed Propulsion Company P. O. Box 111 Redlands, California 92374	
ATTN: Miss Belle Berlad, Librarian	1

	<u>Copies</u>
<p>McDonnell Douglas Aircraft Company Santa Monica Division 3000 Ocean Park Boulevard Santa Monica, California 90406</p> <p>ATTN: J. L. Waisman</p>	1
<p>Monsanto Research Corporation Dayton Laboratory Station B, Box 8 Dayton, Ohio 45407</p> <p>ATTN: Library</p>	1
<p>North American Rockwell Corporation Space & Information Systems Division 12214 Lakewood Boulevard Downey, California 90242</p> <p>ATTN: Technical Information Center, D/096-722 (AJ01)</p>	1
<p>Northrop Corporate Laboratories Hawthorne, California 90250</p> <p>ATTN: Library</p>	1
<p>Rocket Research Corporation 520 South Portland Street Seattle, Washington 08108</p>	1
<p>Rocketdyne, A Division of North American Rockwell Corporation 6633 Canoga Avenue Canoga Park, California 91304</p> <p>ATTN: Library, Dept. 596-306</p>	1
<p>Sandia Corporation Livermore Laboratory P. O. Box 969 Livermore, California 94551</p> <p>ATTN: Technical Library (RPT)</p>	1
<p>United Aircraft Corporation United Aircraft Research Laboratories East Hartford, Connecticut 06118</p> <p>ATTN: D. A. Scola</p>	1

Copies

Aerospace Corporation
P. O. Box 95085
Los Angeles, California 90045

ATTN: Library-Documents 1

American Cyanamid Company
1937 West Main Street
Stamford, Connecticut 06902

ATTN: Security Officer 1

ARO, Incorporated
Arnold Engineering Development Center
Arnold Air Force Station, Tennessee 37389

ATTN: B. H. Goethert, Chief Scientist 1

AVCO Corporation
Space Systems Division
Lowell Industrial Park
Lowell, Massachusetts 01851

ATTN: Library 1

Battelle Memorial Institute
505 King Avenue
Columbus, Ohio 43201

ATTN: Report Library, Room 6A 1

The Boeing Company
Aero Space Division
P. O. Box 3707
Seattle, Washington 98124

ATTN: Ruth E. Peerenboom (1190) 1

Celanese Research Company
Morris Court
Summit, New Jersey

ATTN: J. R. Leal 1

Copies

United Aircraft Corporation
Pratt and Whitney Aircraft
East Hartford, Connecticut

ATTN: Library

1

United Aircraft Corporation
United Technology Center
P. O. Box 358
Sunnyvale, California 94088

ATTN: Library

1

Westinghouse Electric Corporation
Westinghouse Research Laboratories
Pittsburgh, Pennsylvania

ATTN: Library

1