

The contents of this report are not to be used for advertising, publication, or promotional purposes. Citation of trade names does not constitute an official endorsement or approval of the use of such commercial products.



DISCLAIMER NOTICE



THIS DOCUMENT IS BEST QUALITY AVAILABLE. THE COPY FURNISHED TO DTIC CONTAINED A SIGNIFICANT NUMBER OF PAGES WHICH DO NOT REPRODUCE LEGIBLY.

A Conceptual Design for Underwater Installation of Geomembrane Systems on Concrete Hydraulic Structures

by J. Chris Christensen, Matthew A. Marcy

Oceaneering Technologies, Inc.
501 Prince George's Boulevard
Upper Marlboro, MD 20772

Alberto M. Scuero, Gabriella L. Vaschetti

SIBELON U.S.A., Inc.
P. O. Box 22738
Lexington, KY 40522

Final report

Approved for public release; distribution is unlimited

Prepared for U.S. Army Corps of Engineers
Washington, DC 20314-1000

Under Contract No. DACW39-94-C-0034
Work Unit 32636

Monitored by U.S. Army Engineer Waterways Experiment Station
3909 Halls Ferry Road, Vicksburg, MS 39180-6199



**US Army Corps
of Engineers**
Waterways Experiment
Station

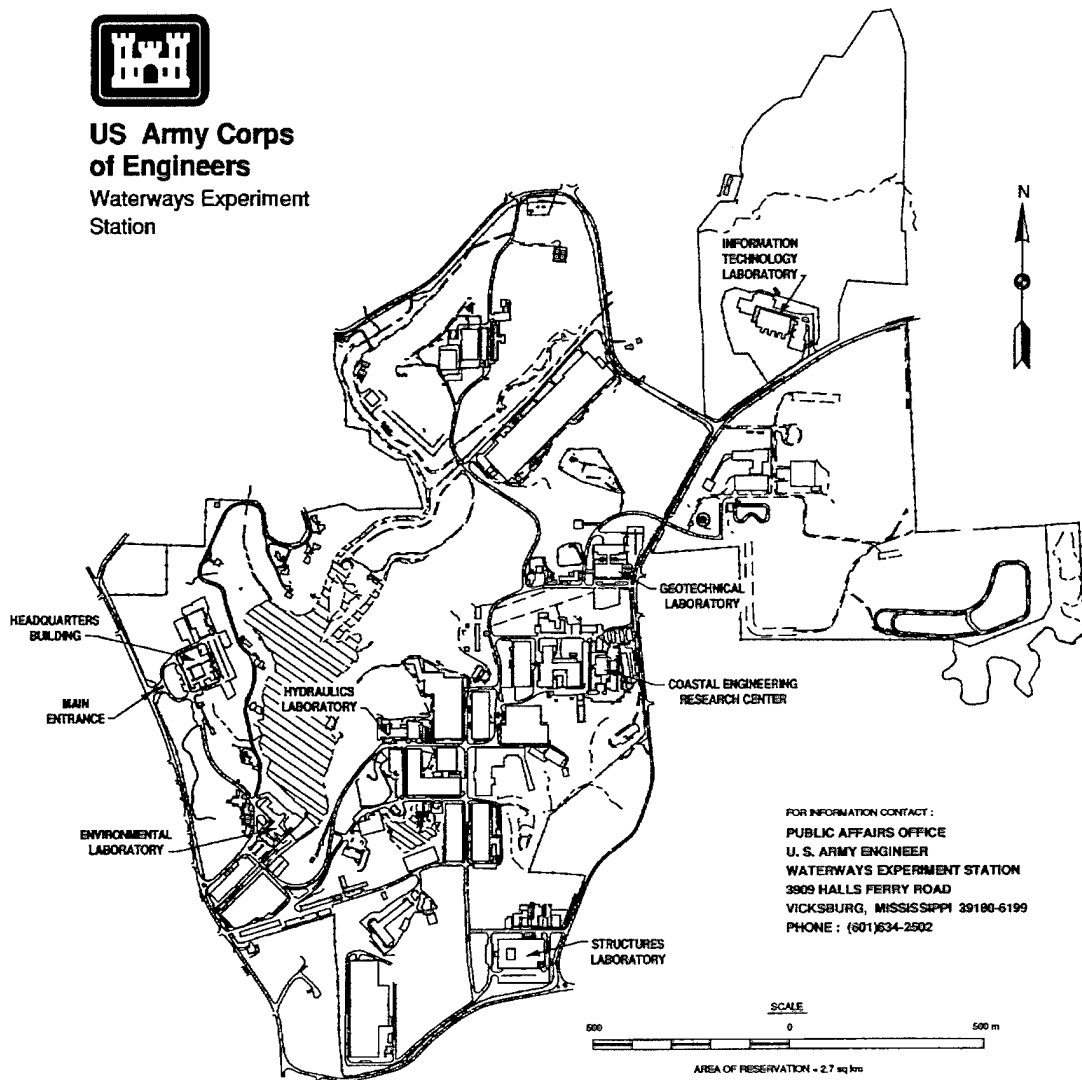

Waterways Experiment Station Cataloging-in-Publication Data

A conceptual design for underwater installation of geomembrane systems on concrete hydraulic structures / by J. Chris Christensen ... [et al.] ; prepared for U.S. Army Corps of Engineers ; monitored by U.S. Army Engineer Waterways Experiment Station.

102 p. : ill. ; 28 cm. — (Technical report ; REMR-CS-50)

Includes bibliographic references.

1. Geomembranes. 2. Concrete dams. 3. Hydraulic structures.

I. Christensen, J. Chris. II. United States. Army. Corps of Engineers.

III. U.S. Army Engineer Waterways Experiment Station. IV. Repair, Evaluation, Maintenance, and Rehabilitation Research Program.

V. Title. VI. Series: Technical report (U.S. Army Engineer Waterways Experiment Station) ; REMR-CS-50.

TA7 W34 no.REMR-CS-50

Contents

Preface	vii
Conversion Factors, Non-SI to SI Units of Measurement	viii
1—Introduction	1
Objective	3
Scope	3
2—Design Considerations	5
Underwater Working Environment	6
Scenarios	6
Scope of Design	7
General Selection Criteria	7
3—Description of Study and Analysis	9
Drainage and Discharge System	9
Drainage material selection	10
Drainage water collection	11
Drainage water discharge system	11
Testing	12
Membrane Material	14
Selection criteria	14
Survey	16
Testing	16
Multiaxial tests	18
Seismic test	36
Summary	38
Mechanical Fastening	38
Anchor bolts	38
Perimeter profiles and gaskets	45
Gasket and profile conformability test	47
Profile stiffness test	49
Gasket pressure test	51
Gasket compression test	52
Vertical splice joint profiles and seals	54
Concrete Surface Preparation	55

4—Discussion	57
Components	57
System	58
Installation Procedure	60
5—Conclusions and Recommendations	64
References	67
Bibliography	68
Appendix A: Glossary of Terms and Abbreviations	A1
Appendix B: SIBELON SYSTEMS Dams/CSE	B1
Appendix C: GeoSyntec Report	C1

List of Figures

Figure 1. Membrane installation with and without drainage	3
Figure 2. Typical drainage and collection scheme	10
Figure 3. Typical discharge systems	11
Figure 4. Drainage test apparatus	13
Figure 5. Influence of substrate conditions on the membrane	18
Figure 6. Puncture/burst test apparatus	19
Figure 7. Simulated substrate in the puncture/burst test	20
Figure 8. Puncture/burst test - PVC after 24-hr loading; no failure; conforms to substrate	22
Figure 9. Puncture/burst test - PVC-R after 24-hr loading; no failure; conforms to substrate	22
Figure 10. Puncture/burst test - CSPE-S after 24-hr loading; excessive permanent deformation at pyramids and cavity	23
Figure 11. Puncture/burst test - PP-R after 24-hr loading; excessive permanent deformation at pyramids	23
Figure 12. Puncture/burst test - EPDM after 24-hr loading; no failure; conforming fairly well to substrate	24
Figure 13. Puncture/burst test - HDPE after rupture at 0.3 MPa; poor conformability	24
Figure 14. Puncture/burst test - HDPE after rupture at 0.15 MPa; poor conformability	25

Figure 15.	Burst test apparatus	26
Figure 16.	PVC during loading in the burst test	27
Figure 17.	Burst test - PVC-R during loading	27
Figure 18.	Burst test - PVC-R after burst; failure mode indicates isotropy and homogeneity	28
Figure 19.	Burst test - CSPE-S during loading	29
Figure 20.	Burst test - CSPE-R during loading	29
Figure 21.	Burst test - PP-R during loading 32	30
Figure 22.	Burst test - EPDM during loading	30
Figure 23.	Burst test - HDPE at burst; off-center failure location indicates dishomogeneity	31
Figure 24.	Burst test - HDPE after burst	32
Figure 25.	Membrane material evaluation for underwater installation . .	36
Figure 26.	Seismic testing equipment	37
Figure 27.	Anchor-bolt pullout test equipment	40
Figure 28.	Steel fails before epoxy on encapsulated resin with epoxy filler anchor	43
Figure 29.	Pullout failure of encapsulated resin anchor	44
Figure 30.	Pullout failure of impact set anchor. The anchor displaced approximately 1/4 in. and then the steel failed in tension.	45
Figure 31.	Illustration of profiles and gaskets	46
Figure 32.	Concrete test slab details for profile/gasket conformability test	48
Figure 33.	Profile and gasket conformability test: 1-in.-thick open-cell neoprene gasket compressed by a stainless steel profile with 12-in. anchor-bolt spacing	49
Figure 34.	Stainless-steel profile, 1/4-in.-thick, compressing channel-shaped, open-cell neoprene gasket	50
Figure 35.	Stainless-steel profile, 1/8-in.-thick, compressing channel-shaped, open-cell neoprene gasket. Profile is too flexible to compress gasket evenly.	51
Figure 36.	Apparatus for gasket pressure test	52
Figure 37.	Pressure differential versus compression deflection in gasket pressure test	53
Figure 38.	Gasket compression device	53
Figure 39.	Results of gasket compression test	54

Figure 40.	Underwater application of concrete repair compound	56
Figure 41.	System general scheme	58
Figure 42.	Assembly detail A from general scheme (Figure 41)	59
Figure 43.	Perimeter seal	59
Figure 44.	Vertical splice	60
Figure 45.	Conceptual design of concrete structure for proposed feasibility demonstration	66

List of Tables

Table 1	Research Team	5
Table 2	Multiaxial Puncture Test Results Summary	21
Table 3	Multiaxial Tests Membrane Material Evaluation	33
Table 4	Membrane Material Evaluation for Underwater Installation	35
Table 5	Anchor Bolts Tested	40
Table 6	Anchor Bolt Test Results	43
Table 7	Performance Analysis	45
Table 8	Epoxy Comparison Results	56
Table 9	Applicability of System Configurations	65

Preface

The study reported herein was authorized by Headquarters, U.S. Army Corps of Engineers (HQUSACE), under Civil Works Research Work Unit 32636, "New Concepts in Maintenance and Repair of Concrete Structures," for which Mr. James E. McDonald, Structures Laboratory (SL), U.S. Army Engineer Waterways Experiment Station (WES), is the Principal Investigator. This work unit is part of the Concrete and Steel Structures Problem Area of the Repair, Evaluation, Maintenance, and Rehabilitation (REMR) Research Program.

The REMR Technical Monitor is Dr. Tony C. Liu, HQUSACE. Mr. William N. Rushing (CERD-C) is the REMR Coordinator at the Directorate of Research and Development, HQUSACE. Mr. James E. Crews (CECW-O) and Dr. Liu (CECW-EG) serve as the REMR Overview Committee. Mr. William F. McCleese, WES, is the REMR Program Manager. Mr. McDonald is the Problem Area Leader for Concrete and Steel Structures.

The study was performed by Oceaneering Technologies, Inc., and SIBELON, U.S.A., Inc., under contract to WES. The work was conducted under the general supervision at WES of Mr. Bryant Mather, Director, SL, and Mr. McCleese, Acting Chief, Concrete Technology Division (CTD), and under the direct supervision of Mr. McDonald. This report was prepared by Messrs. J. Chris Christensen and Matthew A. Marcy, Oceaneering Technologies, Inc., Upper Marlboro, MD, and Messrs. Alberto M. Scuero and Gabriella Vaschetti, SIBELON, U.S.A., Inc., Lexington, KY.

At the time of publication of this report, Director of WES was Dr. Robert W. Whalin. Commander was COL Bruce K. Howard, EN.

Conversion Factors, Non-SI to SI Units of Measurement

Non-SI units of measurement used in this report can be converted to SI units as follows:

Multiply	By	To Obtain
degrees (angle)	0.01745	radians
feet	0.3048	metres
foot pounds (force)	1.355818	joules
inches	25.4	millimetres
pounds (force)	4.448222	newtons
pounds (force) per square inch	0.006894757	megapascals
To obtain Celsius (C) temperature readings from Fahrenheit (F) readings, use the following formula: $C = (5/9)(F - 32)$. To obtain Kelvin (K) readings, use $K = (5/9)(F - 32) + 273.15$.		

1 Introduction

The U.S. Army Corps of Engineers operates and maintains a wide range of hydraulic structures, including concrete gravity dams, embankment and rockfill dams, roller-compacted concrete (RCC)¹ dams, mass concrete gravity navigation locks, U-framed reinforced-concrete navigation locks, mass concrete and reinforced concrete retaining walls, and concrete-lined canals. In addition, many of these structures have concrete appurtenances such as emergency spillways, intake towers, outlet works, conduits, and stilling basins. Located at over 600 project sites throughout the United States, these structures are exposed to a wide spectrum of environmental conditions which, in conjunction with their advancing ages (more than 40 percent are over 50 years old), increases the likelihood of damage resulting from concrete deterioration.

Concrete deterioration occurs for a variety of reasons, some related to the concrete itself and others due to the structure behavior or its external environment. Concrete shrinkage, poor consolidation during construction, improper execution of lifts or construction joints, and alkali-aggregate reaction are all related to the concrete itself. Structure behavior can lead to deterioration either at the foundation level (differential settlement, erosion, degradation of foundation, deterioration of drainage and grout curtains) or in the body of the structure (loss of strength through repeated actions, deformation, loss of bond between concrete structures and embankment). Finally, the environment may affect deterioration through chemical reactions, the influence of temperature changes, or poor resistance of the concrete to freezing and thawing cycles (International Commission on Large Dams (ICOLD) 1994).

In many cases, concrete deterioration leads to the formation of cracks. The resulting water seepage is undesirable not only because of water loss, but also because infiltration of water into the structure can have significant negative effects such as an increase in uplift pressures. When water seepage reaches unacceptable levels, repairs must be made either locally or over the entire surface of the structure. Repair procedures are designed to halt further

¹ For convenience, a glossary of terms and abbreviations is presented in Appendix A.

seepage and, if possible, to dehydrate the water infiltrated structure and restore the initial design conditions.

Local repairs generally consist of cementitious or chemical grouting of the cracks and defective joints. This type of repair will normally correct specific problems but affords no protection against further deterioration and may have little effect on water infiltration into the structure.

Repairs to the entire surface can be made either with traditional materials and techniques or with new synthetic organic materials. Traditional materials such as concrete, shotcrete, bituminous membranes, resins, and steel plates have been widely used in the rehabilitation of hydraulic structures. However, all of these methods have limitations, especially from the standpoint of an underwater installation.

Geomembranes and geocomposites have been used as impervious barriers in dams, particularly in Europe, for more than 30 years (ICOLD 1991). Geomembranes have been successfully used to rehabilitate concrete, masonry, rockfill, and gravity and concrete arch dams including multiple and double curvature arches. Geomembranes and geocomposites have also been used to line reservoirs, canals, and tunnels and to provide a water retention barrier on the upstream face of new dams constructed with RCC.

Geosynthetic liners can be installed with or without a drainage system (Figure 1). There are substantial differences between these two repair methods. Absence of drainage causes water to be "trapped" between the membrane and the structure surface. This can result in damage to the liner in the presence of severe temperature conditions (water between the membrane and structure surface turns to ice or vapor, thus exerting stresses on the back of the system and on the liner) and in further deterioration of the surface concrete (Cazzuffi 1987). In contrast, a drained system allows immediate and continuous discharge of seepage water, be it coming from the reservoir or from the structure body due to temperature variations, thus:

- a. Minimizing the potential for damage to the liner.
- b. Minimizing the extent of concrete saturation and subsequent deterioration through alkali-aggregate reaction, chemical reactions, and cycles of freezing and thawing.
- c. Providing a possible means for monitoring seepage.
- d. Providing a means of removing water which has infiltrated into the cracks, voids, and porous regions of the structure in the presence of wide thermal ranges.

Selected applications of geomembrane systems in repair of concrete hydraulic structures were summarized by McDonald (1993). The success of

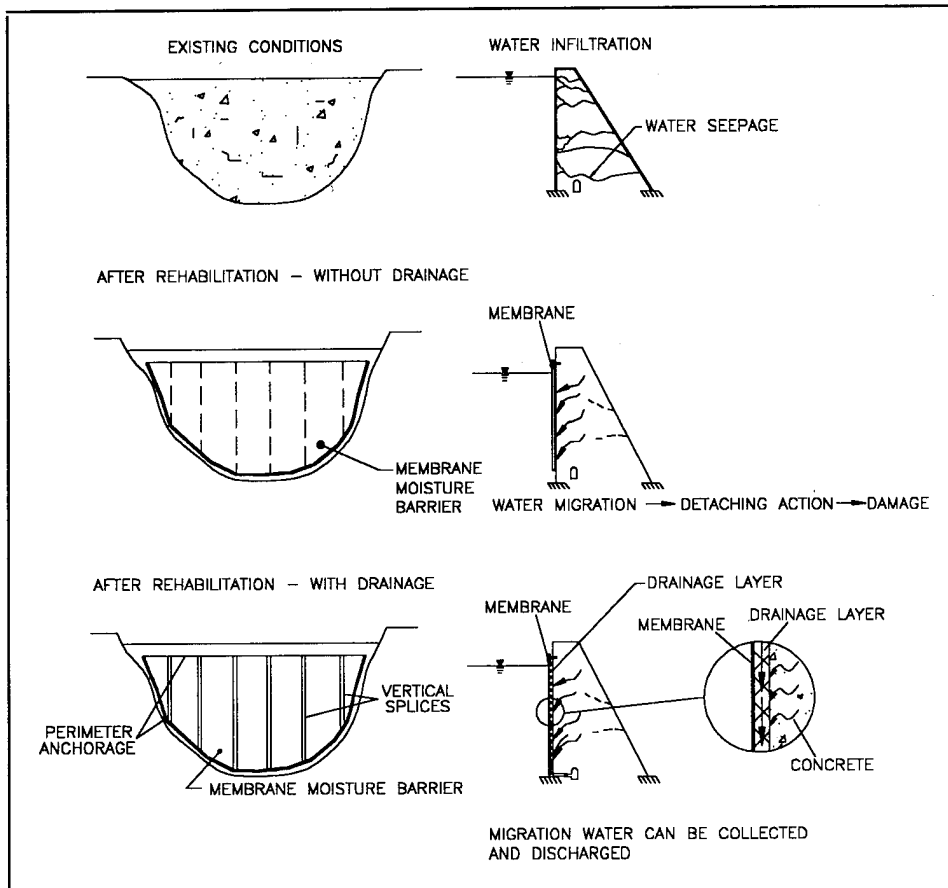

Figure 1. Membrane installation with and without drainage

these systems in controlling leakage and arresting concrete deterioration and the demonstrated durability of these materials are such that these systems are considered competitive with other repair alternatives. However, in nearly all cases, geomembrane installations to date have been accomplished in a dry environment by dewatering the structure on which the liner is to be installed. Dewatering of structures owned and operated by the Corps of Engineers can be extremely expensive and in many instances may not be possible because of project constraints. A geomembrane system that could be installed underwater would have significantly increased potential in repair of hydraulic structures.

Objective

The overall objective of this research program was to develop a membrane system that can be installed underwater to minimize or eliminate water intrusion through cracked or deteriorated concrete and defective joints.

Scope

Development of a reliable design and underwater installation procedure for a geomembrane repair system must include thorough analysis of the problem, conceptual exploration, system design, and validation. The study was designed to accomplish these tasks in three phases:

Phase I. Conduct research, material testing, and detailed evaluation of individual components and techniques resulting in the design of one or more complete systems for the proposed underwater installation.

Phase II. Demonstrate the feasibility of the systems designed in Phase I through the underwater installation of a membrane on a small-scale structure located in a test basin or other suitable controlled environment.

Phase III. Confirm the applicability of the selected system in the field through a full-scale underwater installation on an existing structure to be designated and provided by the U.S. Army Corps of Engineers.

This report covers Phase I of the study. The objective of this phase was to perform research, material testing, and evaluation of individual components and techniques required to facilitate successful underwater installation of membranes and to develop a procedure for underwater installation.

2 Design Considerations

The objective of the research program was pursued by the combined efforts of a multidisciplinary team consisting of the following individuals listed in Table 1:

Table 1 Research Team		
Team Member	Company	Area of Expertise
John S. Christensen	Oceaneering	Commercial diving/underwater construction
Matthew A. Marcy	Oceaneering	Civil engineering/commercial diving
Andrew Weysham	Oceaneering	Commercial diving/underwater construction
Alberto M. Scuero	SIBELON, U.S.A.	Hydraulic and civil structures construction and repair-Geosynthetics
Gabriella L. Vaschetti	SIBELON, U.S.A.	Geosynthetics application to hydraulic structures rehabilitation
Ezio L. Laveriotti	SIBELON, U.S.A.	Technical study and design for geosynthetic application
José L. Machado Do Vale	SIBELON, U.S.A.	Technical study and design for geosynthetic application
Paola A. Ravaldini	SIBELON, U.S.A.	Membrane testing

SIBELON SYSTEMS, a concrete rehabilitation method, has proven effective when installed in the dry. This drained membrane system consists of a flexible polyvinyl chloride (PVC) liner which is mechanically anchored to the surface of the structure with stainless steel profiles. Pertinent features of this system are summarized in Appendix B.

The material used is a special PVC geocomposite, consisting of a PVC geomembrane of a particular compound, plasticized and stabilized to Ultraviolet (UV) rays, and coupled during extrusion to a polyester geotextile. The liner has outstanding physical, mechanical, and chemical characteristics to guarantee reliable and long service life.

The liner is anchored along the perimeter with metal profiles. Profiles are the batten strips which provide linear anchorage of the membrane to the

upstream face of the dam. Anchorage is watertight wherever there is a possibility of water by-passing the impermeable barrier. Junctions between adjoining sheets are accomplished by means of vertical stainless steel profiles, whose coupling assures anchorage to the substrate and pretensioning of the sheets and provides a free-flow conduit for drainage water.

Linear anchorage of the sheets to the substrate allows drainage of seepage water behind the liner. Drained water is also conveyed by high-transmissivity layers to a collection point at the heel of the structure and then discharged.

To modify the design and procedures for an underwater installation, the peculiarities of the working environment were investigated. While the design function of the underwater application is the same as that of the system installed in the dry, certain design criteria changed.

Underwater Working Environment

The buoyancy of objects must be accounted for when working underwater. Buoyancy can often be used to assist the manipulation of objects underwater, but it can also hinder underwater efforts. Generally speaking, large objects must be negatively buoyant to allow efficient movement and positioning.

Labor efficiency is reduced underwater. Life support systems must be manned. For safety reasons, fewer laborers can be working on the repair at any given time. Most construction tasks are more time-consuming underwater because of decreased mobility. Visibility is decreased due to turbidity of the water. Certain tasks such as welding geosynthetics are not currently feasible on an industrial scale. Furthermore, the time each diver spends underwater must be limited to prevent decompression sickness. In summary, underwater labor, while reliable if conducted properly, is expensive. The design should include measures to minimize work required underwater.

Scenarios

Certain scenarios to be dealt with are unique to an underwater installation. Repairs in the dry nearly always involve rehabilitation of the entire surface of a structure, with factory-sized sheets, after a certain degree of substrate preparation, and installation of a drained membrane. This is not always the scenario for underwater installations. Size and location of the repair, substrate preparation, and the use of drainage will vary for underwater installations.

Since underwater labor is expensive, a cost/benefit analysis of conditions at a particular site may show that a small local repair is the only feasible option. For local repairs, the benefit of drainage is very small. Therefore, the design must allow for scenarios where a membrane patch is applied without drainage.

If a larger surface is being addressed and the width of the manufactured sheet is not sufficient, vertical junction of sheets are required. This entails designing an underwater junction method and construction of larger prefabricated sheets. Sheet width should be maximized while still allowing ease of transportation and handling of prefabricated sheets on site.

Substrate preparation will be limited underwater. Major substrate failures can cause considerable water flow through the structure and create a strong suction action on the membrane during installation. This makes the design criteria more strict.

Underwater installation may consider a drained and an undrained system, due to cost/benefits evaluation. A drained system offers substantial advantages, but it is more difficult to install and requires a very efficient perimeter seal.

Since there are cases where a drainage system may not be part of the remediation, the fluctuation of the reservoir water level becomes significant. Water-level fluctuations have little effect on systems with drainage. If drainage is omitted and the water level drops, there is a risk of the membrane sagging and becoming damaged.

Scope of Design

The scenarios the research team chose to investigate refer substantially to a rehabilitation of considerable size so as to require vertical junctions of preassembled impermeable sheets, with possibility of drainage behind the liner, and installation of the membrane on a surface with relevant irregularities due to substrate deformations (e.g., defect of formworks at concrete casting, rotation or differential settlements of slabs during service life, as sometimes observed in embankment dams with concrete upstream face, cracks and holes due to concrete deterioration, etc).

This report addresses only cases in which all of the installation is accomplished underwater, since this constitutes the most severe condition. Cases where part of the membrane will be exposed to the atmosphere require site specific considerations, combining dry installation techniques (which have already been developed) and underwater installation techniques (which are addressed in the present research).

General Selection Criteria

The research team, relying on the experience of their members, decided that selection criteria should be based on the following considerations:

- a. Application: To concrete water retention structures (dams and their appurtenances).

- b.* Objectives of the installation: The same as for installation in the dry (i.e., stop further water seepage and deterioration, restore impermeability of the deteriorated dam face, dehydrate the dam body of previously infiltrated water, and restore safety factor to original values).
- c.* General design: As similar as possible to what has already proven to be efficient and reliable in the dry, and such as to allow the repetition of a basic scheme as a submultiple which, duly repeated, can allow repair of large surfaces as well as small areas.
- d.* Assembly and anchorage techniques: As similar as possible to what has already been done in the dry, although taking into account problems connected with water turbidity, water currents, buoyancy of materials, safety of the working conditions (underwater welding of sheets will be discarded because it is not feasible using known available technology) and, necessary operating equipment (cranes and pontoons).
- e.* Materials: If possible, the same used in the dry, but taking into account that the importance of some fundamental properties of the system components may be weighted differently in underwater applications.
- f.* Costs: The design must provide a system whose installation cost is affordable.

3 Description of Study and Analysis

Research methods for this phase included developing design criteria, surveying available materials, conducting material testing, and evaluating materials and assembly techniques. Material testing was conducted, when applicable, in accordance with standardized tests. However, other even more valuable information was collected with nonstandardized tests, namely with multiaxial, large-scale tests, or tests which were intended to simulate conditions likely to be encountered during actual installation. Testing was conducted on drainage materials, membrane materials, anchorage profiles, gaskets, anchor bolts, and surface repair compounds.

Drainage and Discharge System

The patented membrane system that has been demonstrated by SIBELON in numerous dry installations is a drained system. Drainage provides a means of extracting infiltrated water, be it from the reservoir or from the dam body or foundations, and serves the function of dehydrating the concrete structure which reduces uplift pressures. Drainage also follows good practice guidelines to reduce unnecessary contact between moisture and concrete in an effort to reduce alkali-aggregate reactions (AAR). Additionally, drainage provides a means of monitoring the flow of water behind the membrane. This monitoring provides verification of sealing performance and immediately detects a compromise in the barrier. The research team believes that the substantial advantages offered by drainage can be maintained in an underwater installation for certain applications.

Drainage is accomplished by installing a highly transmissive material between the surface to be repaired and the geomembrane. The transmissive material provides a drainage layer where atmospheric pressure is maintained. Water travels through the transmissive material in a preselected direction to a perimeter collection system (Figure 2). The collection system transports the water to discharge points for removal from the system. Proper ventilation is required to prevent a vacuum effect in the standoff area.

The temperature differential between the concrete structure and the upstream face provides energy for the migration of water from the structure toward the surface. In an underwater installation, the temperature differential will be smaller. Consequently the dehydration process will be less efficient. However, if atmospheric pressure is maintained in the drainage area, the thermal inertia differential between concrete and water will promote dehydration.

Drainage system design must take into account factors which vary from site to site (e.g., drainage slope, repair surface area, type of structure, etc). Careful analysis of the situation must be conducted to ensure system integration of transmission, collection, and discharge.

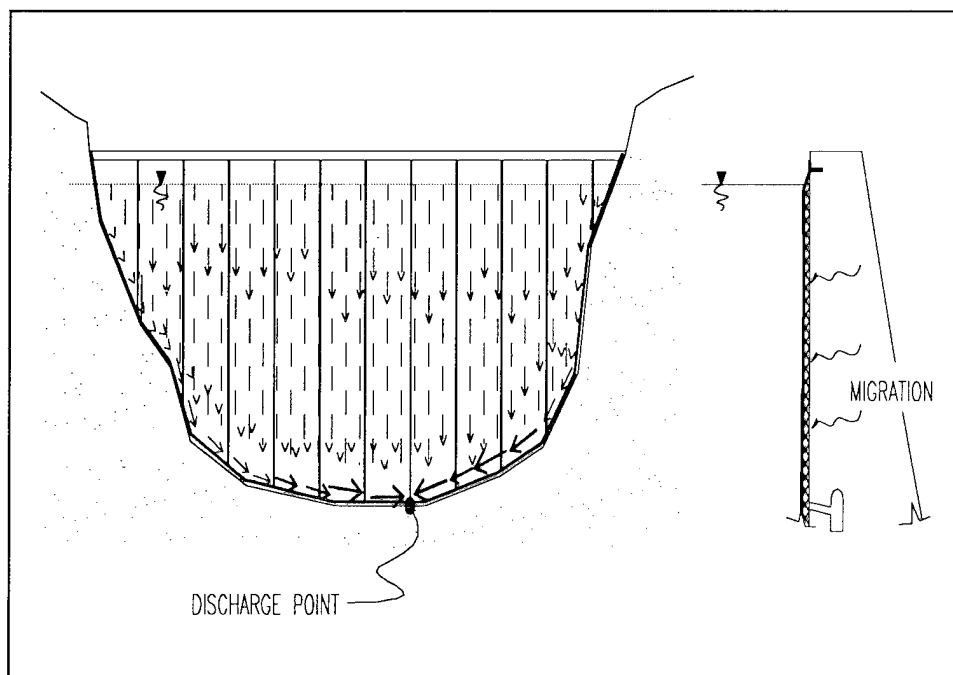

Figure 2. Typical drainage and collection scheme

Drainage material selection

Criteria for the selection of drainage material are transmissivity, durability, and conformability. Transmissivity is a measure of the efficiency by which water can flow through the material. Vertical transmissivity is preferred, but transmissivity in other directions can be acceptable depending on the collection and discharge system. Durability is the ability to withstand wear or decay over time. The material must be resistant to rotting. Conformability is the ability to take on the shape of the substrate. The drainage material must be able to conform without losing its transmissivity.

Drainage water collection

Water collection and conveyance along the bottom of the repair can be achieved by additional drainage layers such as geonets oriented so the flow is directed toward a discharge point. Several layers with suitable inclination can be installed, depending on the drainage capacity required. This can be easily installed underwater. If a higher drainage capacity is required, alternative solutions include the use of pipes or special profiles. Such appurtenances will be covered by the membrane and have suitable inclination to ensure sufficient water flow. Site-specific design details must address the junctions of pipes and/or profiles and the feasibility and ease of making the proper connections underwater.

Drainage water discharge system

Drainage water can be discharged as shown in Figure 3. Upstream discharge does not affect the structure and is in our opinion more feasible to install underwater. Upstream discharge can be accomplished by pumping drained water through a pipe installed through the membrane at the lowest point of the repair. Operations will include:

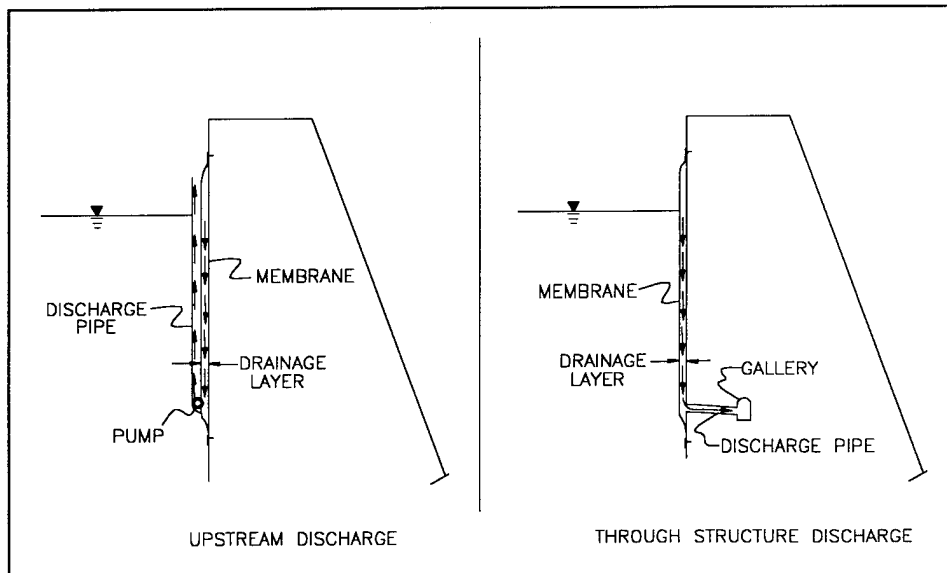

Figure 3. Typical discharge systems

- a. Installation of a drain pipe at the proper low point of the repair.
- b. Connection of a vertical discharge pipe to the drain pipe; impermeability will be guaranteed by a cover strip and watertight profile.
- c. Installation of a submersible pump.

- d.* If desired, installation of a monitoring device to measure drained water flow.

In some cases, it may be more feasible to drill through the structure to accomplish drainage. This would be possible where the structure at the drainage point is not excessively thick or the presence of a drainage or grouting gallery would allow the drilling to be accomplished without undue complications. The procedure will include:

- a.* Installation of a steel plate on the face of the structure at the location of the drainage hole.
- b.* Drilling through the dam body to the water discharge point.
- c.* Insertion of a discharge pipe in the drilled hole.
- d.* Plugging of the pipe at the downstream end.
- e.* Removal of the steel plate and connection of the through-pipe to the water collection system.

Whatever discharge system is adopted, ventilation is required to eliminate negative pressure which would inhibit discharge.

In the case of small repairs, the benefits obtained with drainage would be less significant. A membrane system without drainage is generally recommended for small repairs.

Detailed design of a drainage, collection, and discharge systems is site specific. Generally speaking, the design will provide for the direction of the drainage water coming from the repair surface toward a collection and discharge point and a method of discharge.

Testing

The geosynthetic industry supplied data concerning the drainage capacity of highly transmissive materials. The research team, however, believes efficiency of the entire system should be ascertained by testing. A test chamber was therefore designed and constructed purposely for this project to provide qualitative verification by visual means. See Figure 4 for an illustration of this apparatus.

The test chamber allows simulation of hydraulic heads up to 60 m. It consists of a fixed frame and a mobile frame, operated by a hydraulic cylinder capable of separating the two frames up to 700 mm to allow installation of the different elements to be tested.

The fixed frame consists of a sheet of transparent plastic mounted on a steel frame. The drainage material and membrane to be tested are mounted against this surface such that the efficiency of the drainage system can be observed visually through the transparent plastic during the test. Once the drainage material and membrane are installed on the fixed frame, the mobile and fixed frames are bolted together with a pressure-tight gasket between the two, creating a pressure chamber.

On top of the test chamber are air and water inlet valves, a pressure gauge, and a safety valve. The air valve on top of the mobile frame allows the tester to vary the air pressure in the pressure chamber during the test. The water valve and flow meter on top of the fixed frame supplies water to the drainage layer behind the membrane, and three valves on the bottom of the fixed frame allow evaluation of different water collection and conveyance systems.

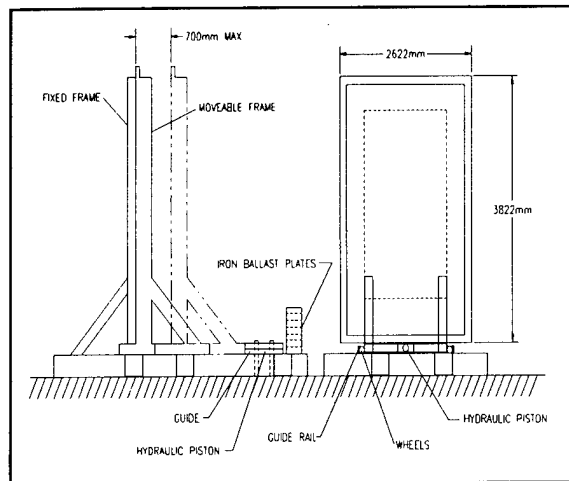

Figure 4. Drainage test apparatus

Once the drainage system selected for testing is installed and the frames are bolted together, the desired pressure is established in the pressure chamber and the gap between the membrane and the drainage system is filled with a measured amount of water. The air inlet is then either closed or left open, depending on whether atmospheric or negative pressure is desired. As discharge valves are opened, the equipment allows visual monitoring of the path of the drained water and measuring of the discharge time.

Tests were performed to verify behavior of two-dimensional and three-dimensional geonets. Results confirmed materials met manufacturers' specifications with respect to transmissivity. Comparison between drainage at atmospheric pressure and drainage at a pressure depression confirmed what the research team has already found in field experiments — negative pressure in the drainage system should be avoided to ensure efficient drainage.

Predicting the actual behavior of the system based on the results of small-scale tests is difficult. Further large-scale study and testing is recommended for major rehabilitation projects.

Material selection has to be evaluated with regard to transmissivity, puncture resistance, and constructability. Collection and discharge design is site specific. Performance of the various elements must be balanced. Testing

of the entire designed drainage system is always recommended, especially when drainage is an important issue of the project.

Membrane Material

The membrane material serves the function of a moisture barrier between the water and the structure. The synthetic membrane must perform adequately and guarantee a fairly long service life.

Selection criteria

A reliable material must have the following characteristics in order of decreasing importance.

- a.* Very low permeability.
- b.* High resistance to tensile stress, pressure, puncture.
- c.* Elastic behavior, with high-percentage elastic elongation.
- d.* High resistance to the service environment.
- e.* Ease of junctions to allow construction of large prefabricated sheets.
- f.* Satisfactory performances in previous applications.
- g.* Repairability.
- h.* Acceptable cost.
- i.* Availability.

Materials considered were those which have already proved to be suitable for application to hydraulic structures in the dry. Proof of suitability is determined by experience in the field or manufacturers' specification with sufficient support and credibility.

Some materials, although belonging to the same group, have highly different characteristics and performances. Others, although with different characteristics and costs, have similar performances. The research team's approach was to survey the products of several manufacturers for each material type, to evaluate different thicknesses for each material, and to rely on their experience for critical examination and evaluation.

As reinforcement generally enhances mechanical performance, the survey included a number of available reinforced membranes, either with scrim

reinforcement or with backing. A membrane with scrim reinforcement has reinforcement fibers within the membrane sheet, whereas a membrane with backed reinforcement has a geotextile bonded to one side of the membrane sheet.

The backed reinforcement is generally deemed superior over the scrim reinforcement. That is true especially for our application because it is stronger, is not subject to potential delamination of the layers coupled together (a problem with scrim reinforcement), and provides additional puncture resistance and a transition layer. Considering that best results have been so far provided by geocomposites with backing coupled during manufacturing, the research was focused mainly on these products. Due to manufacturer's recommendations, one scrim-reinforced geocomposite was also considered for thorough evaluation. Geocomposites chosen above others were therefore PVC/geotextile, polypropylene (PP)/geotextile, chlorosulphonated polyethylene (CSPE)/geotextile, or CSPE/scrim reinforcement.

Selection criteria had to be adapted to the specific environment. For underwater installation applications, characteristics which may not be of concern for installation in the dry can be of significant importance.

With respect to operational concerns, flexibility and seamability are desirable. When a membrane is flexible and easily seamed, larger factory joined sheets can be manufactured, rolled, and transported to the site. This reduces the number of required underwater junctions. If large sheets are deployed during installation, flexibility is required for ease of handling underwater. Density of the membrane is also relevant. It is very difficult for divers to manipulate a membrane that is buoyant. When working with geomembranes underwater, the higher the density, the better. Flexibility, seamability, and density can be combined in the category of constructability.

An underwater installation must also take into consideration the fact that extensive surface preparation can be very difficult, costly, and time consuming. Preparation of the substrate must be minimized. This presents the possibility of protruding points and other irregularities remaining on the structure facing which pose the hazard of puncturing or bursting the membrane. Additionally, the membrane must withstand stress incurred during installation. In summary, it is desirable to select a membrane with mechanical properties of high puncture resistance, high tear resistance, and high tensile strength.

Other parameters to be considered are durability and repairability. Durability is important due to the high installation costs that would be unreasonable for a short life material. As underwater repairs are more complicated than dry repairs, it is important to minimize maintenance requirements and to allow easy and quick repairs. Other properties such as UV resistance or resistance to a wide range of chemicals present a lesser concern underwater.

The research evaluation was qualitative, not quantitative. This evaluation allows for a comparison of available materials and provides a basis for recommending available materials but does not determine material specifications.

Survey

A survey was conducted to investigate membrane materials available on the market that have been widely and successfully used in hydraulic structure rehabilitation. This survey included gathering information from 30 U.S. and European manufacturers' published specifications.

The following materials were surveyed:

- a. Thermoplastic polymers: Polyvinyl chloride (PVC), polyethylene (HDPE, VLDPE), polypropylene (PP), chlorosulphonated polyethylene (CSPE).
- b. Elastomers (rubbers): Isoprene-isobutylene butyl (IIB), ethylene propylene diene monomer (EPDM), chloroprene (CR).

Some of the material candidates were discarded from further investigation due to lack of a suitable reputation or insufficient data as to their performance. For one material, VLDPE, the resin manufacturer has interrupted production and the material is no longer available. The remaining candidates were PVC, CSPE, EPDM, PP, and HDPE.

Testing

The research team performed a series of tests on the candidate materials to:

- a. Have a uniform testing procedure which could overcome the difficulty in comparing material properties determined in accordance with different standards.
- b. Ascertain mechanical resistance and flexibility characteristics of various membranes with the same testing procedure.
- c. Acquire more information on the membrane behavior by means of multiaxial testing.
- d. Ascertain influence of membrane thickness.
- e. Ascertain influence of membrane reinforcement.

A special mention goes to investigation on HDPE, a material commonly and widely used in the United States in the geosynthetic industry. HDPE did not seem to be a suitable material, due to its density, low flexibility, and

difficulty in junctions. Because of its widespread availability and reputation, testing was performed on it to verify our predictions.

The following specimens were tested:

- a. PVC.
- b. PVC-R with backed reinforcement (geotextile).
- c. CSPE-S with scrim reinforcement.
- d. CSPE-R with backed reinforcement (geotextile).
- e. PP.
- f. PP-R with backed reinforcement (geotextile).
- g. EPDM.
- h. HDPE.

PVC materials evaluated were manufactured in Europe, where PVC is treated with high quality additives to improve its performance with regard to strength, flexibility, and weathering.

Two types of tests were performed: standardized uniaxial tests on small-scale specimens, and large-scale, nonstandardized multiaxial tests.

Standardized tests were conducted in accordance with Ente Italiano di Unificazione (UNI 1988) and International Organization for Standardization (ISO 1977). These test methods were followed in lieu of American Society for Testing and Materials (ASTM) tests because of the team's familiarity with European tests. The following tests were performed:

- | | |
|--------------------------------|---------------------|
| a. Tensile stress | UNI 8202/8 |
| b. Tear resistance | UNI 8202/9 ISO 4674 |
| c. Puncture resistance-static | UNI 8202/11 |
| d. Puncture resistance-dynamic | UNI 8202/12 |

According to the most recent trends in geosynthetics, existing standardized tests are not considered to be reliable methods for determining the overall behavior of a membrane. The uniaxial tests are not representative of actual service loading conditions. On the contrary, large-scale multiaxial testing can better evaluate resistance and flexibility characteristics. The need for multiaxial testing is further justified by the fact that surface conditions in underwater installations are likely to be more irregular because of minimum

surface preparation. Protruding points could cause puncturing, and voids could cause bursting of the membrane (Figure 5). The research team therefore decided to evaluate conformability, puncturing, and bursting characteristics accordingly.

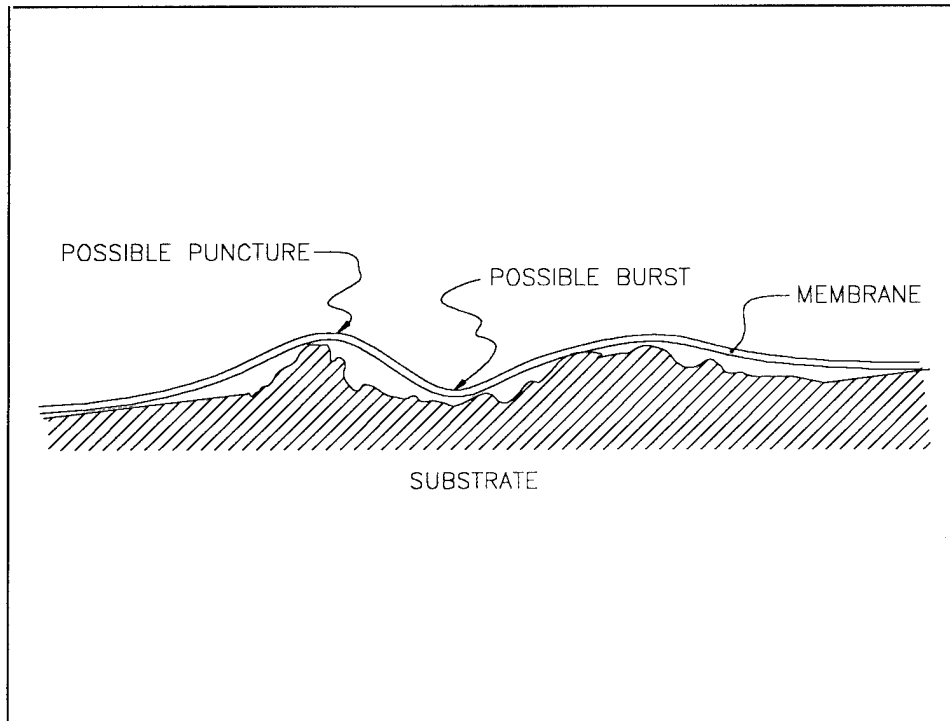

Figure 5. Influence of substrate conditions on the membrane

Multiaxial tests

Two multiaxial tests were performed; puncture/burst test and burst test.

Puncture/burst test. The purpose of this test was to ascertain the material conformability, puncture resistance, and burst resistance in the presence of a fairly rough substrate. With multiaxial loading, it is possible to ascertain the mechanism of deformation of the membrane in critical zones; that is, in correspondence with protrusions where the membrane is exposed to puncturing and in correspondence of voids where it is exposed to bursting.

The test was designed to compare geomembrane/geocomposite materials of various thicknesses under multiaxial loading conditions likely to occur during a material's service life on a concrete hydraulic structure. Testing was performed by using hydraulic pressure to press a membrane sample against a simulated substrate.

The simulated substrate consisted of a sand and gravel layer, on which pyramids with heights varying from 50 to 60 mm were placed. The apex of

the pyramids (70°) was sharp, and other severe irregularities were caused by sharp-edged gravel, with angles smaller than 70° . Photographs of the vessel and the substrate are found in Figures 6 and 7. Internal dimensions of the vessel allowed testing of a circular sample of membrane approximately 0.5 m in diameter.

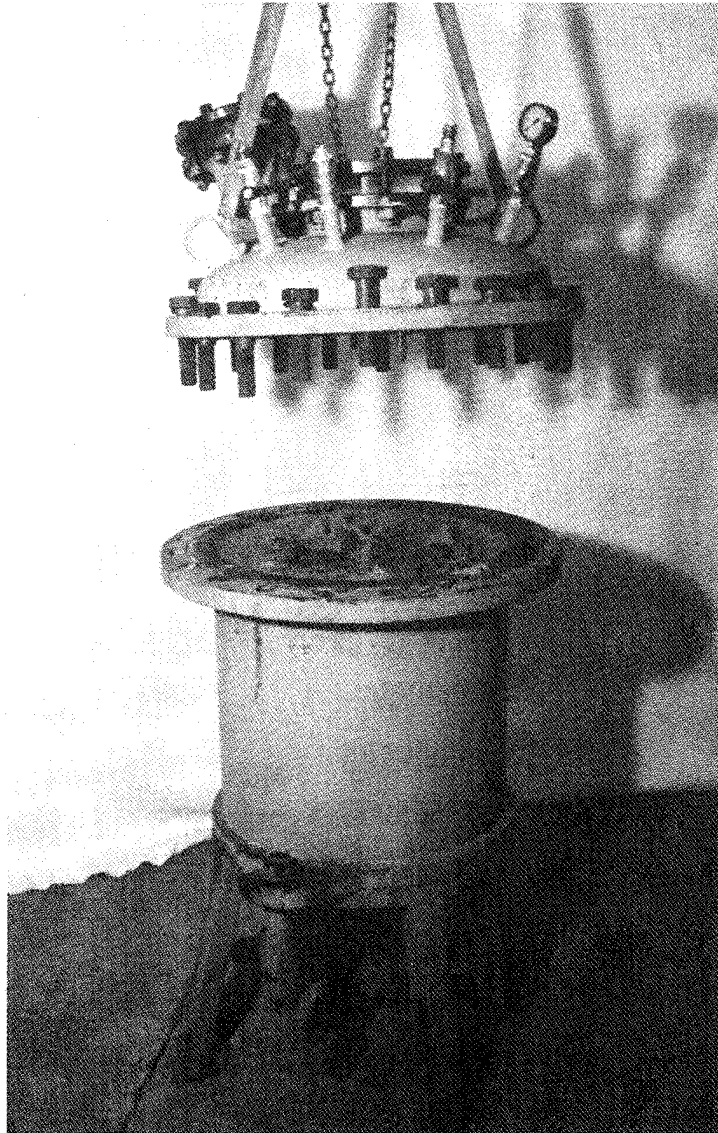

Figure 6. Puncture/burst test apparatus

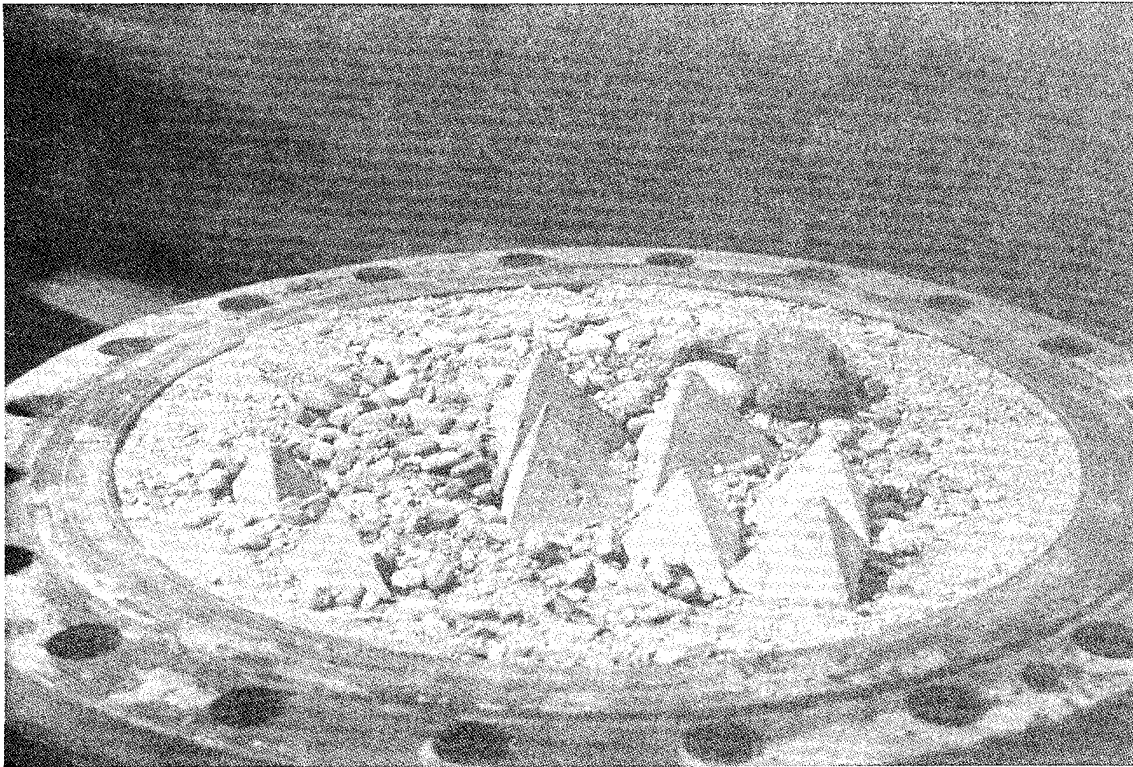

Figure 7. Simulated substrate in the puncture/burst test

The sample is placed in the pressure vessel and the vessel is sealed. The vessel is pressurized at a rate of 0.05 MPa/min until a maximum pressure of 1 Mpa is reached. If the sample has not ruptured, pressure is maintained for 24 hr. The specimen is then removed from the vessel.

The report includes presence and location of ruptures, observations of conformability to the substrate, and observation of deformation after 72 hr of recovery. Results of the puncture tests are summarized in Table 2. Typical results of the puncture test are shown in Figures 8 through 14.

Based on an analysis of puncture test procedures and results, the research team concluded that the simulated substrate represents the most extreme puncture conditions that can actually be encountered in the field. However, the voids do not simulate severe suction actions that can be caused by actual substrate failures. Therefore, bursting of the membrane will be a critical situation likely to be encountered which needs further investigation. Also, the puncture test does not give complete information on materials which ruptured before loading was completed.

Failure is defined as excessive permanent deformation and decrease in material thickness, without rupture.

Table 2
Multiaxial Puncture Test Results Summary

PVC 1 mm	Rupture at 0.6 MPa (between pyramids at cavity). Conforms to substrate - good elastic recovery.
PVC 1.5 mm	Rupture at 1 MPa after 6 hr (at sharp stone). Conforms to substrate - good elastic recovery.
PVC 2 mm	No failure - Conforms to substrate - Very good elastic recovery.
PVC 2.5 mm	No failure - Does not conform perfectly to substrate. Very good elastic recovery.
PVC-R PVC 1 mm + 200 g/m ² NW	Rupture at 1 MPa after 10 hr (between pyramids at cavity). Conforms to substrate - Elastic recovery superior to correspondent unreinforced PVC.
PVC-R PVC 1.5 mm + 200 g/m ² NW	Rupture at 1 MPa after 10 hr (at sharp stone). Conforms to substrate - Elastic recovery superior to correspondent unreinforced PVC.
PVC-R PVC 2 mm + 200 g/m ² NW	No failure - Conforms to substrate. Elastic recovery superior to correspondent unreinforced PVC.
PVC-R PVC 2.5 mm + 500 g/m ² NW	No failure - Conforms to substrate. Elastic recovery superior to correspondent unreinforced PVC.
CSPE-S 1 mm	Rupture at 1 MPa (at pyramids and cavity). Conforms to substrate. Poor elastic recovery.
CSPE-S 1.2 mm	Failure at 1 MPa (at pyramids and cavity). Conforms to substrate. Poor elastic recovery.
CSPE-S 1.4 mm	Failure at 1 MPa (at pyramids and cavity). Conforms to substrate. Poor elastic recovery.
CSPE-R CSPE 0.8 mm + 0.4mm	Rupture at 0.8 MPa (at sharp stone and cavity). Conforms to substrate. Poor elastic recovery.
CSPE-R CSPE 1 mm + 0.4 mm	Rupture at 0.8 MPa (at sharp stone and cavity). Conforms to substrate. Poor elastic recovery.
CSPE-R CSPE 1.2 mm + 0.4 mm	Rupture at 0.8 MPa (at sharp stone and cavity). Conforms to substrate. Poor elastic recovery.
PP 1.5 mm	Failure at 1 MPa (at pyramids and cavity). Conforms to substrate. Poor elastic recovery.
PP-R PP 1.5 mm + 300 g/m ² NW	Failure at 1 MPa (at pyramids). Conforms to substrate. Poor elastic recovery.
EPDM 2 mm	No failure. Conforms fairly well to substrate. Total elastic recovery.
EPDM 3 mm	No failure. Conforms fairly well to substrate. Total elastic recovery.
HDPE 1.5 mm	Rupture at all pyramids at 0.15 MPa. Does not conform to substrate. No elastic recovery.
HDPE 2 mm	Rupture at all pyramids at 0.3 MPa. Does not conform to substrate. No elastic recovery.
HDPE 2.5 mm	Rupture at all pyramids at 0.35 MPa. Does not conform to substrate. No elastic recovery.
Note: NW = Nonwoven	

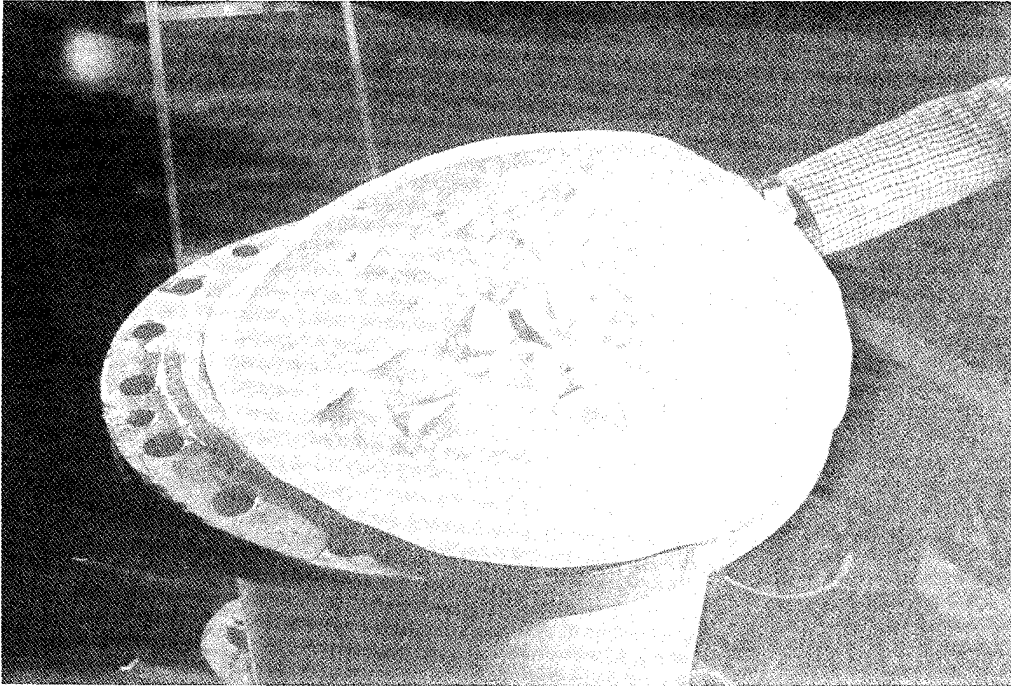

Figure 8. Puncture/burst test - PVC after 24-hr loading; no failure; conforms to substrate

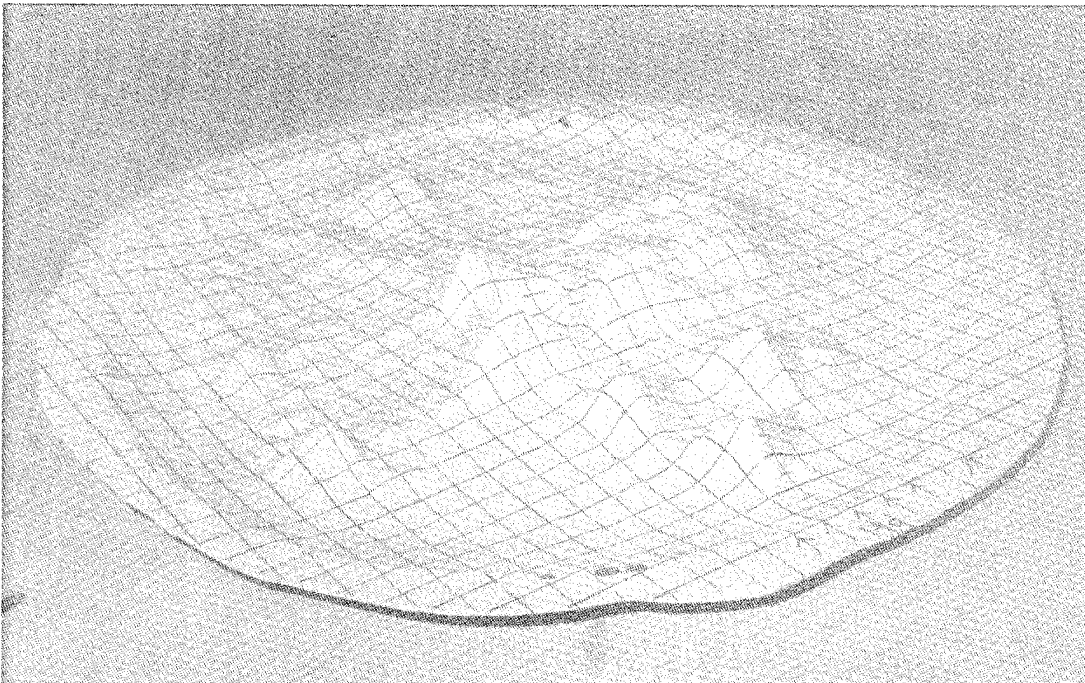

Figure 9. Puncture/burst test - PVC-R after 24-hr loading; no failure; conforms to substrate

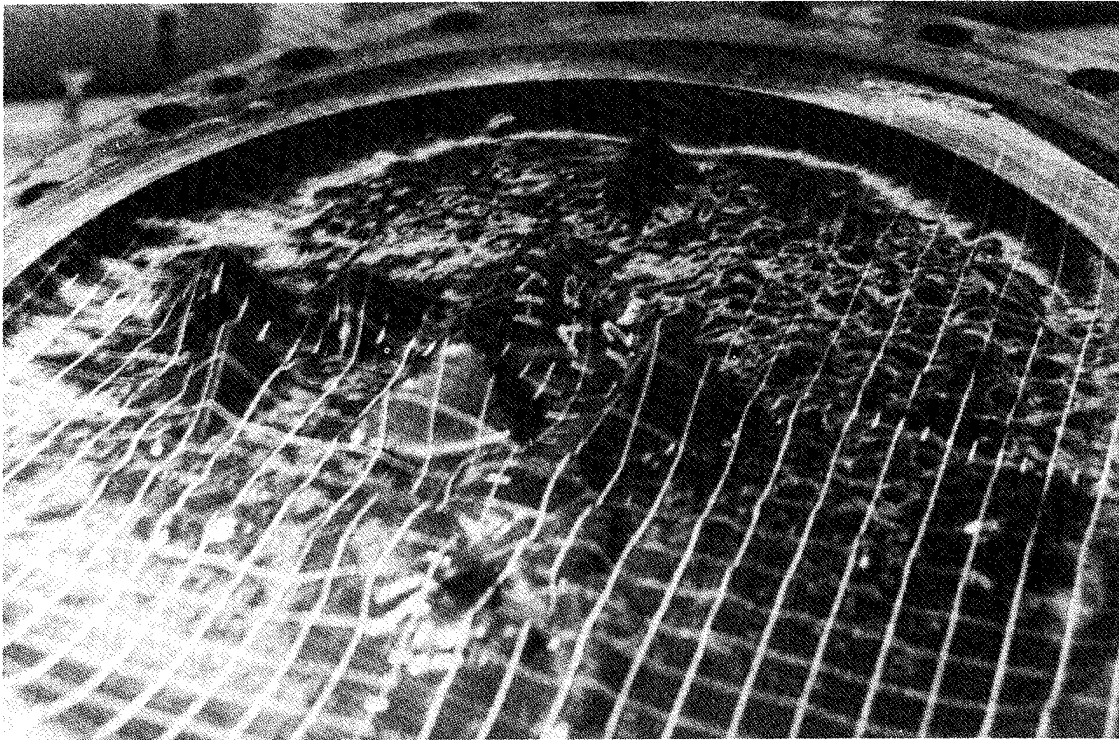

Figure 10. Puncture/burst test - CSPE-S after 24-hr loading; excessive permanent deformation at pyramids and cavity

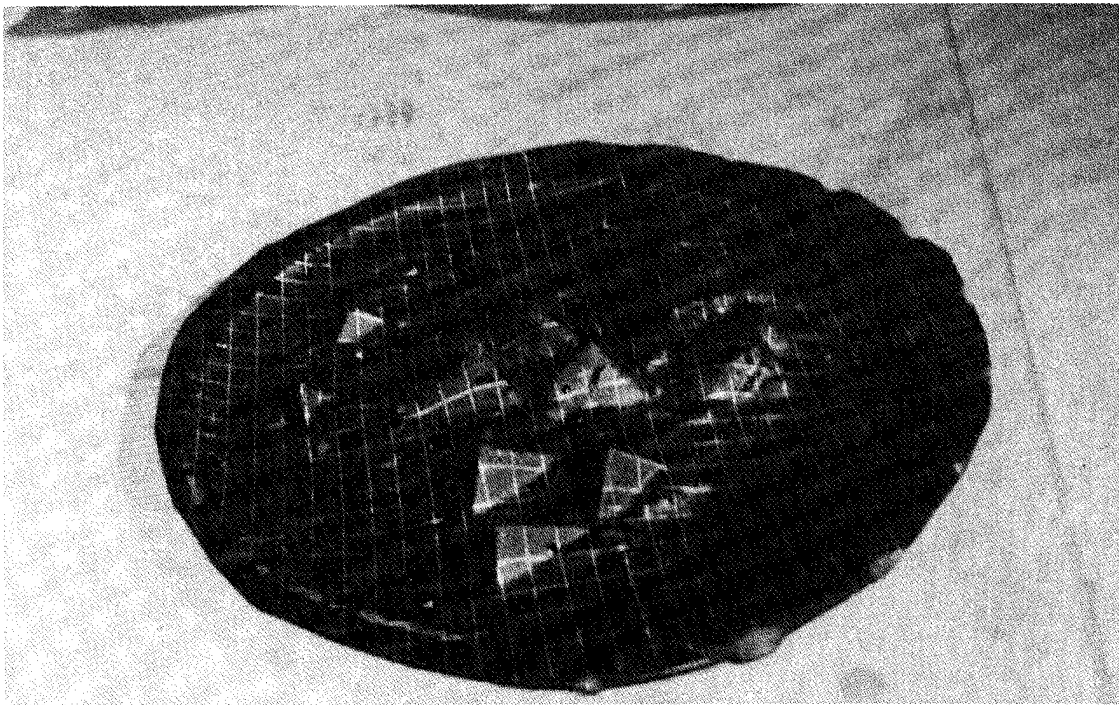

Figure 11. Puncture/burst test - PP-R after 24-hr loading; excessive permanent deformation at pyramids

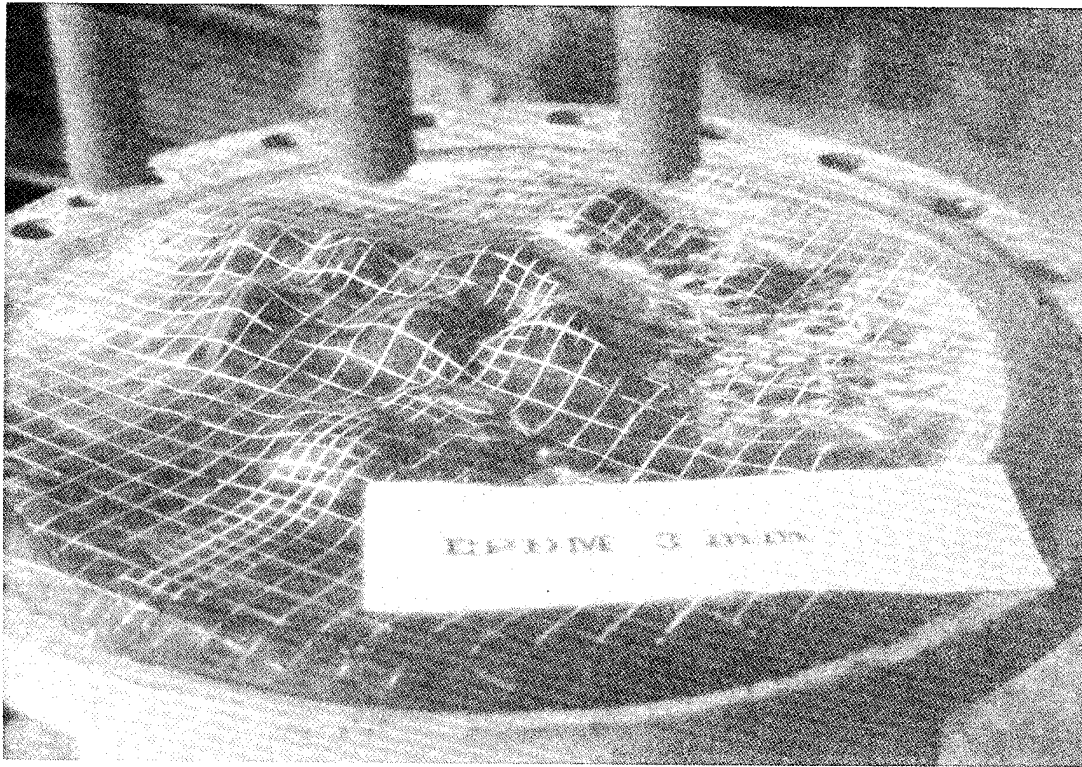

Figure 12. Puncture/burst test - EPDM after 24-hr loading; no failure; conforming fairly well to substrate

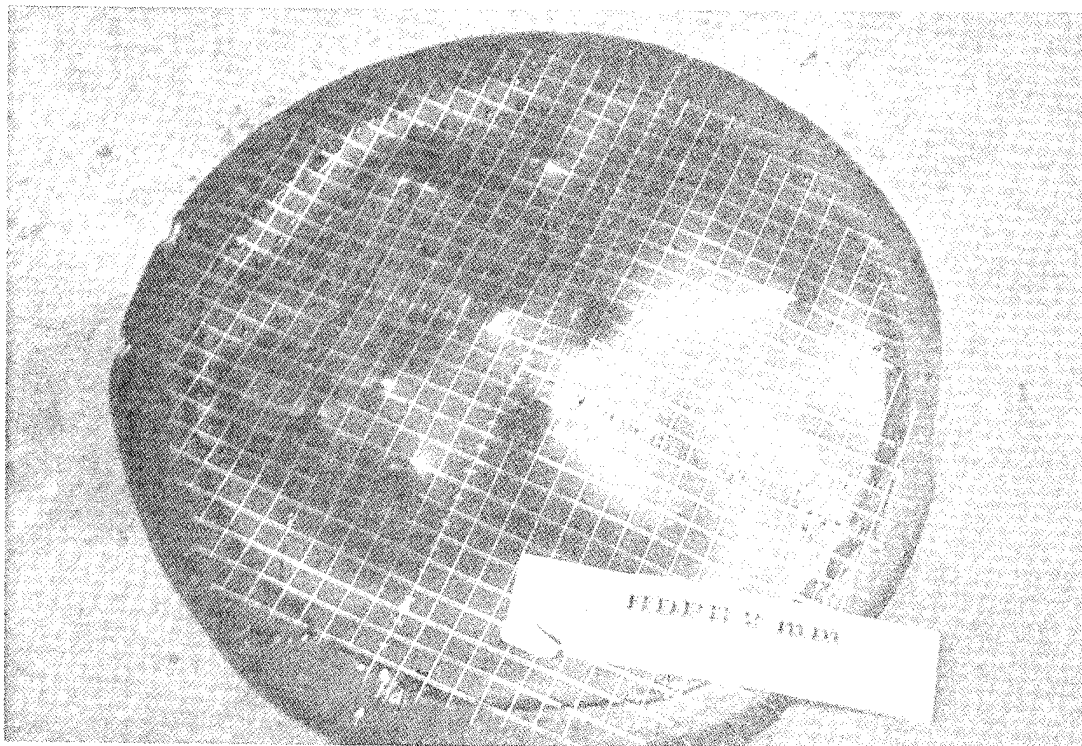

Figure 13. Puncture/burst test - HDPE after rupture at 0.3 MPa; poor conformability

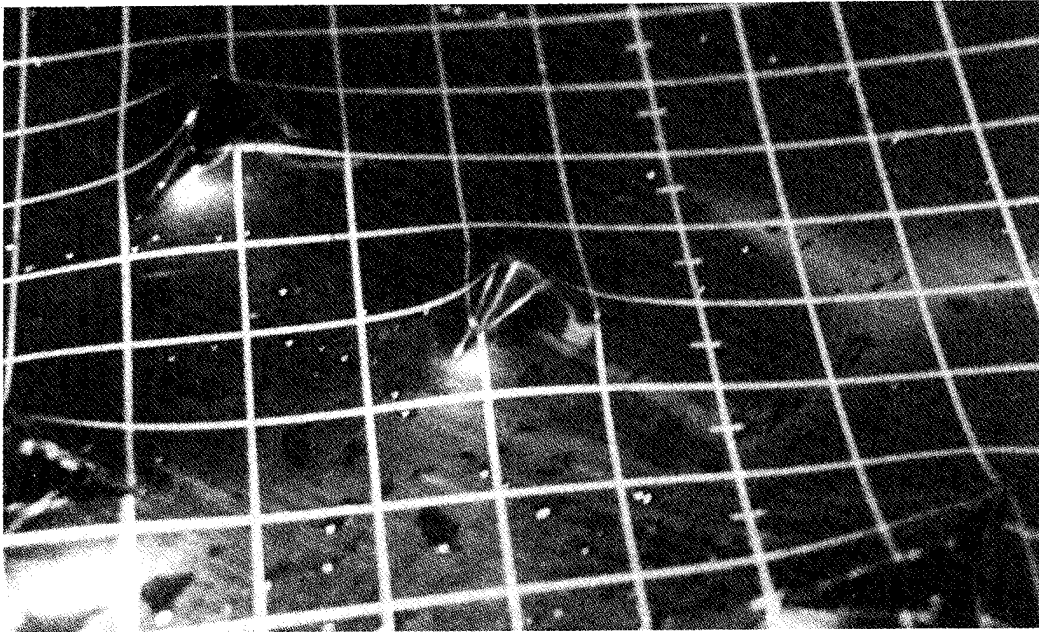

Figure 14. Puncture/burst test - HDPE after rupture at 0.15 MPa; poor conformability

Burst test. Additional multiaxial tests were conducted to investigate the behavior of membranes subjected to bursting pressures. The test was designed to compare performance characteristics of the candidate geomembrane/geocomposite materials with different thicknesses. Homogeneity, isotropy, and capability to deform were observed.

A device suitable for sealing a circular specimen and for regulating a hydrostatic pressure sufficient to burst the sample was constructed. A suitable instrument measures the distance from the center of the deformed membrane to its original plane. Figure 15 contains a photograph of the pressure vessel and measuring device.

Internal dimensions of the apparatus allowed testing of 0.5-m-diam samples of membrane. After the specimen is secured in the pressure apparatus, the deformation measuring device is positioned perpendicular to the specimen so that it butts against its center. Hydrostatic pressure is then increased at a rate of 0.01 MPa/min until the specimen bursts.

The report included observations concerning homogeneity, isotropy, and deformation of the material. Typical results of burst test are shown in Figures 16 through 24.

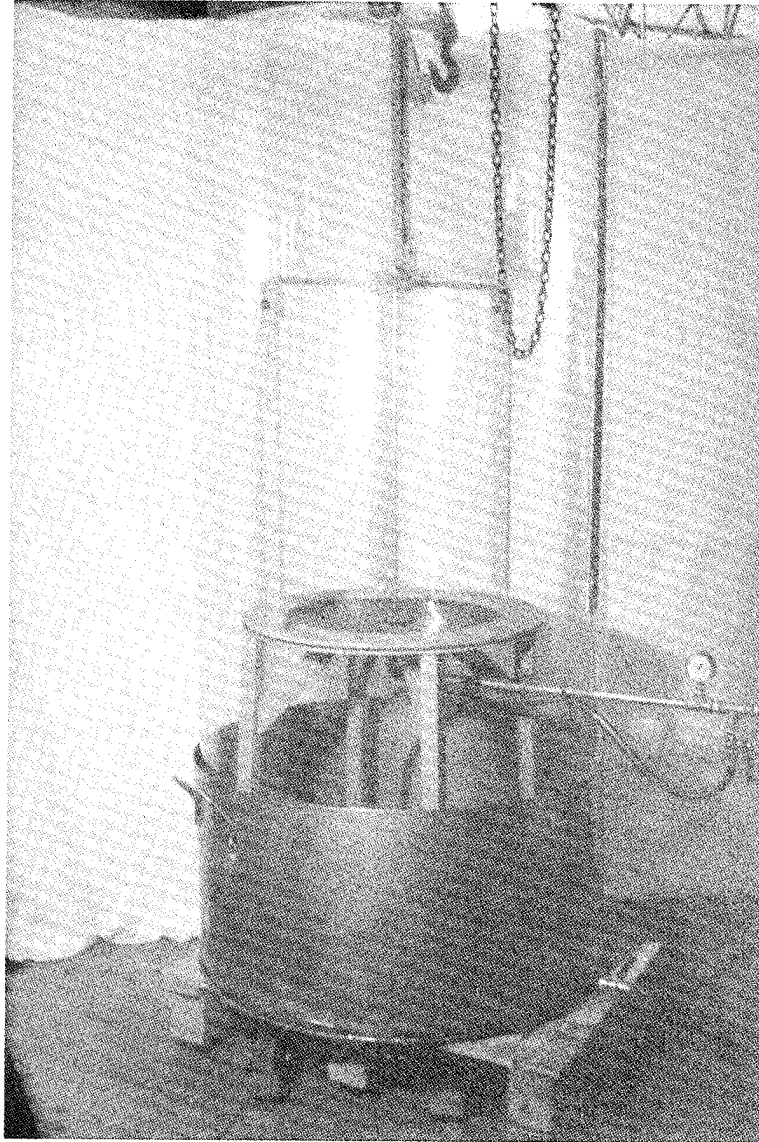

Figure 15. Burst test apparatus

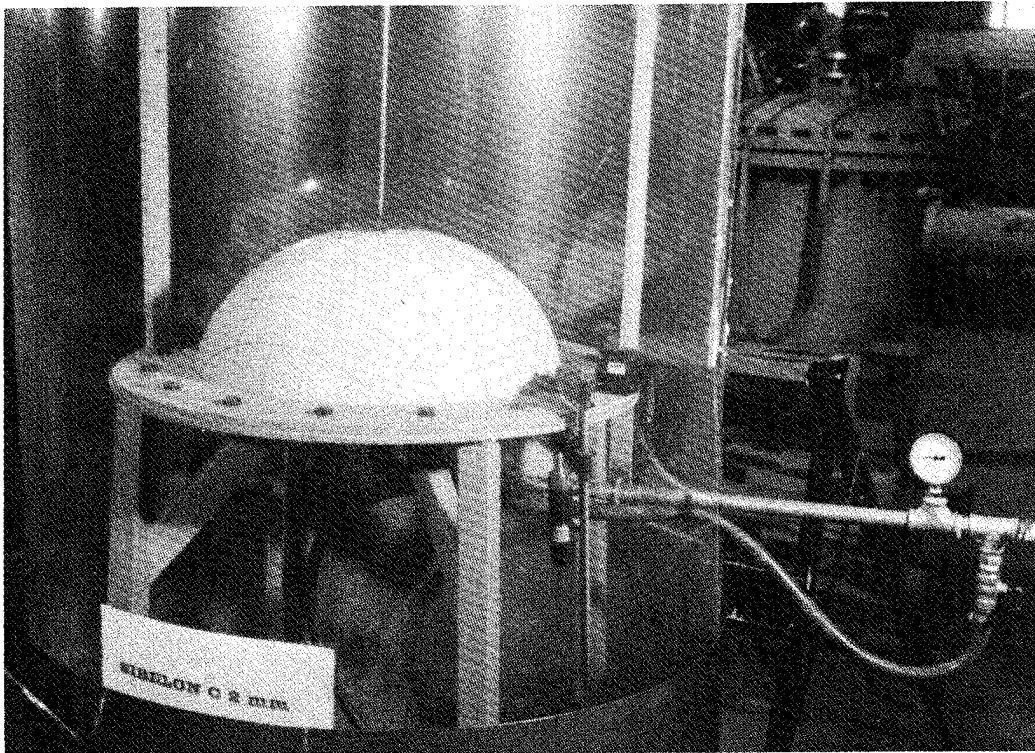

Figure 16. PVC during loading in the burst test

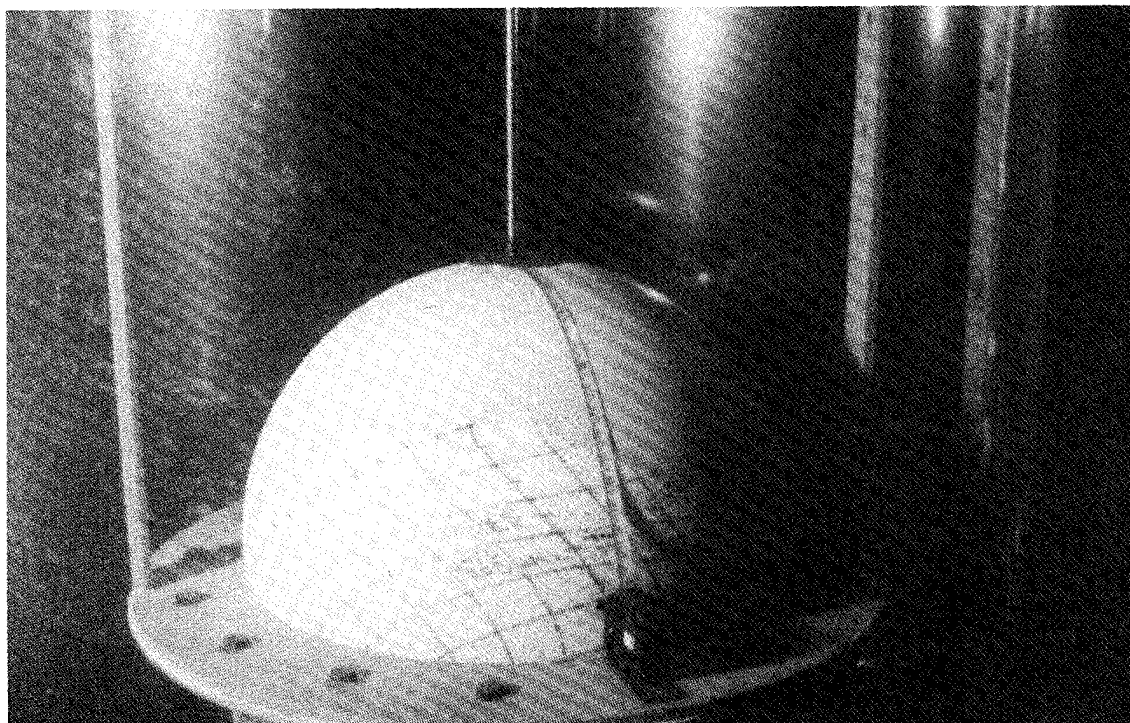

Figure 17. Burst test - PVC-R during loading

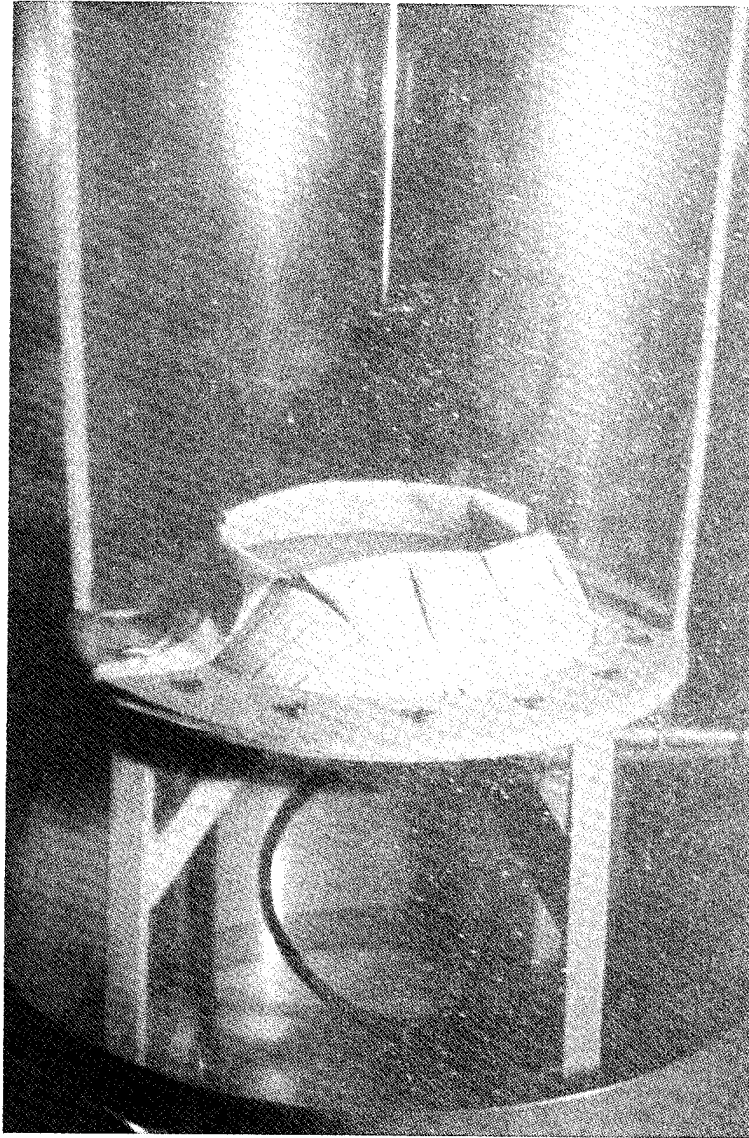

Figure 18. Burst test - PVC-R after burst; failure mode indicates isotropy and homogeneity

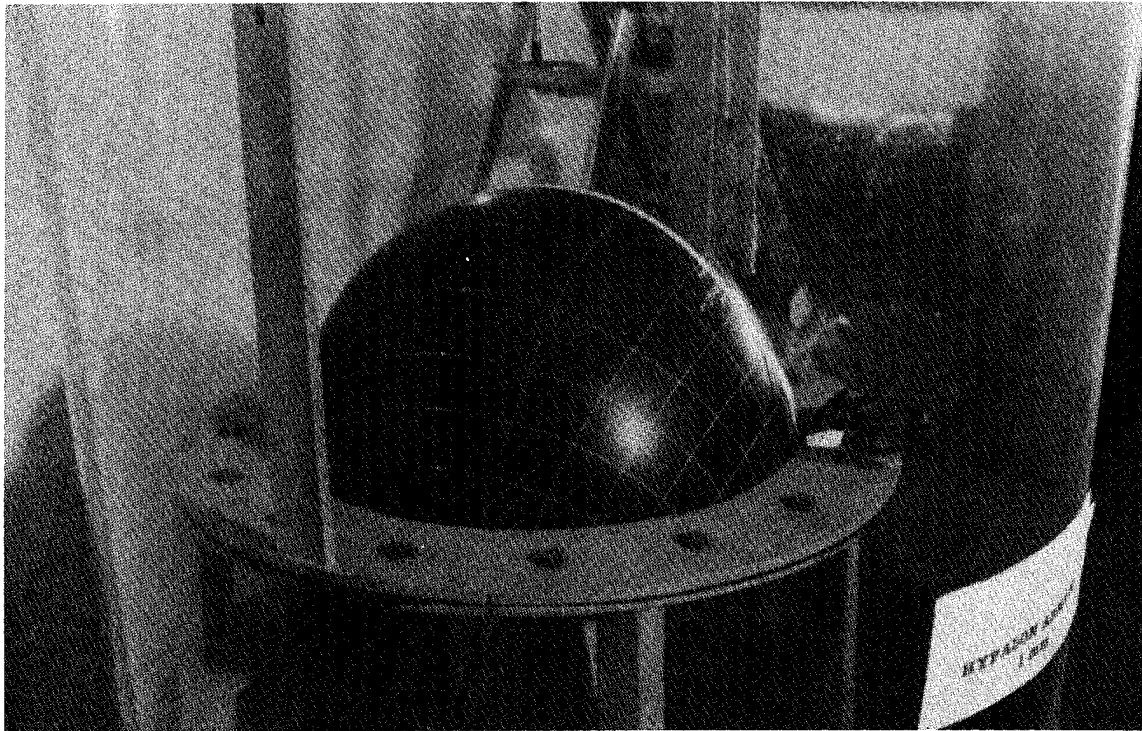

Figure 19. Burst test - CSPE-S during loading

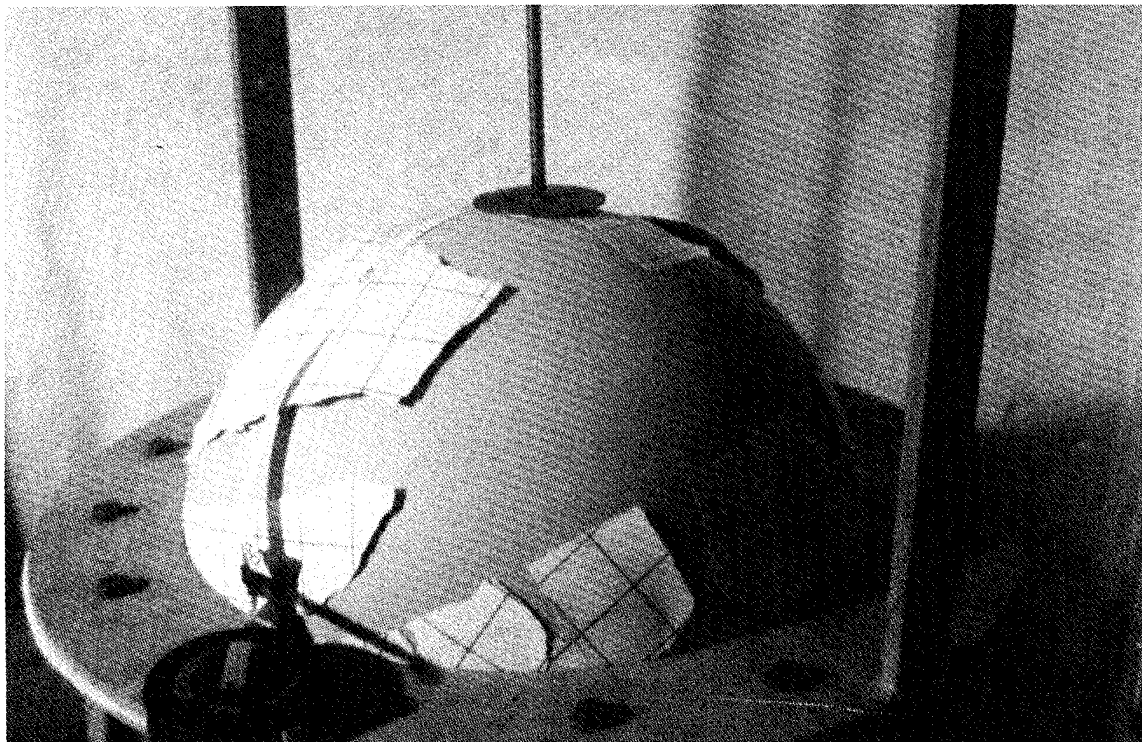

Figure 20. Burst test - CSPE-R during loading

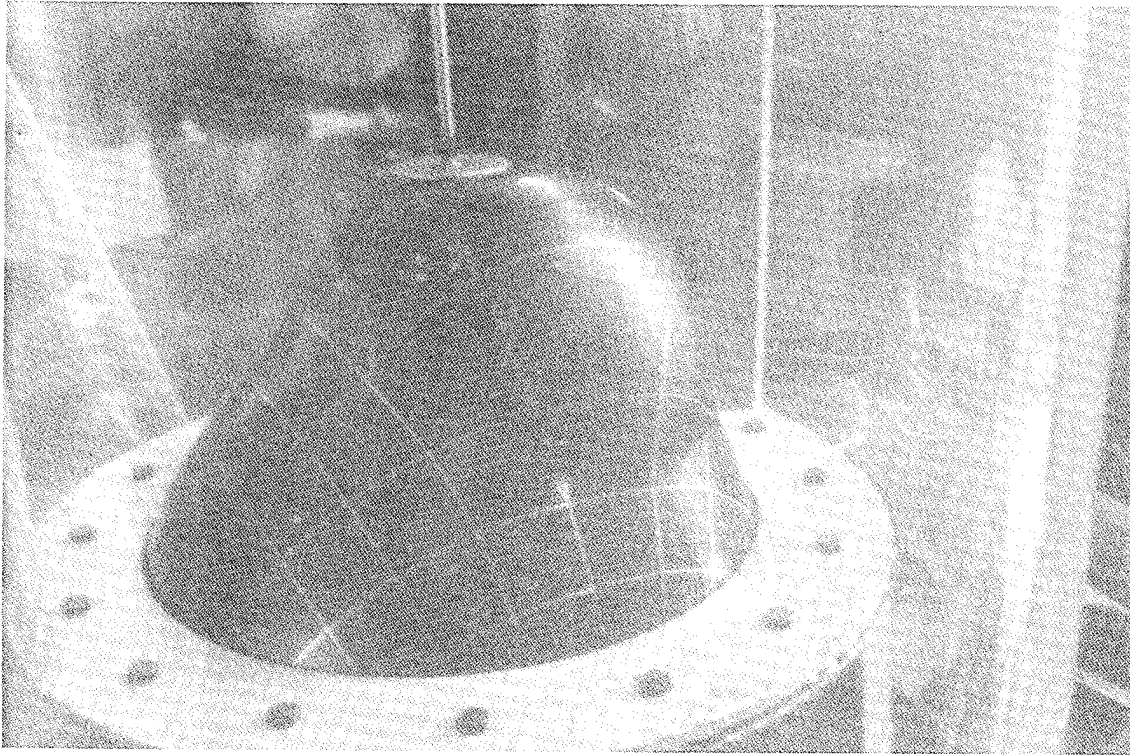

Figure 21. Burst test - PP-R during loading

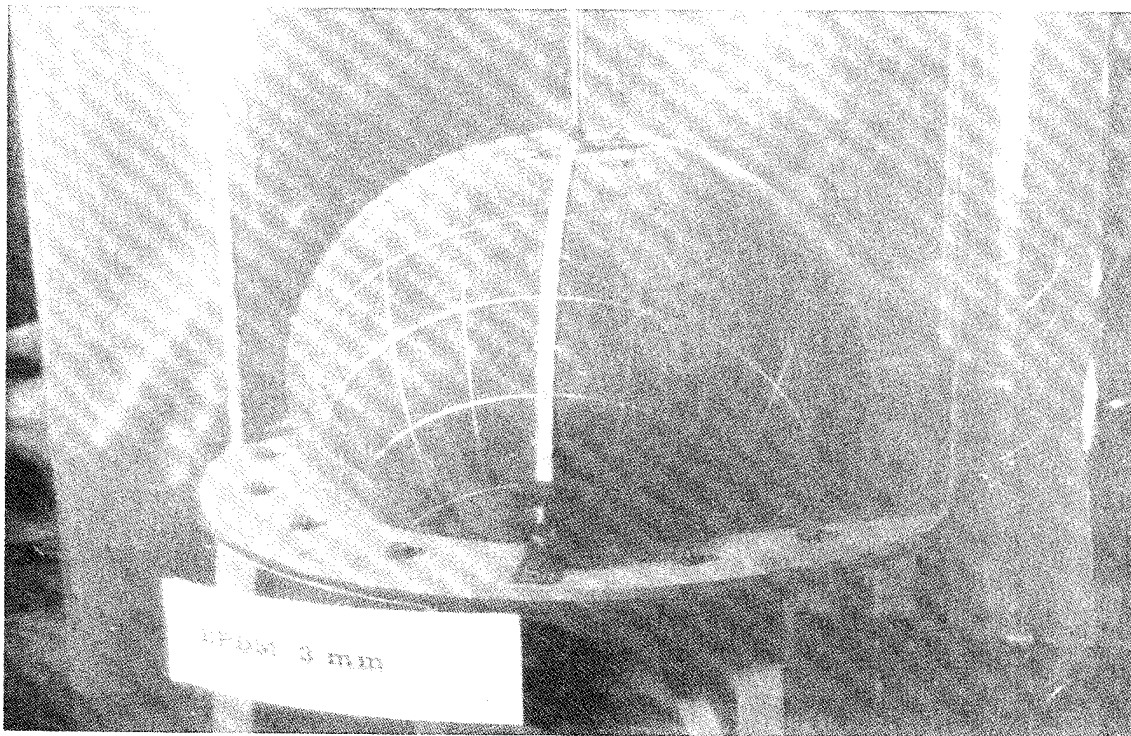

Figure 22. Burst test - EPDM during loading

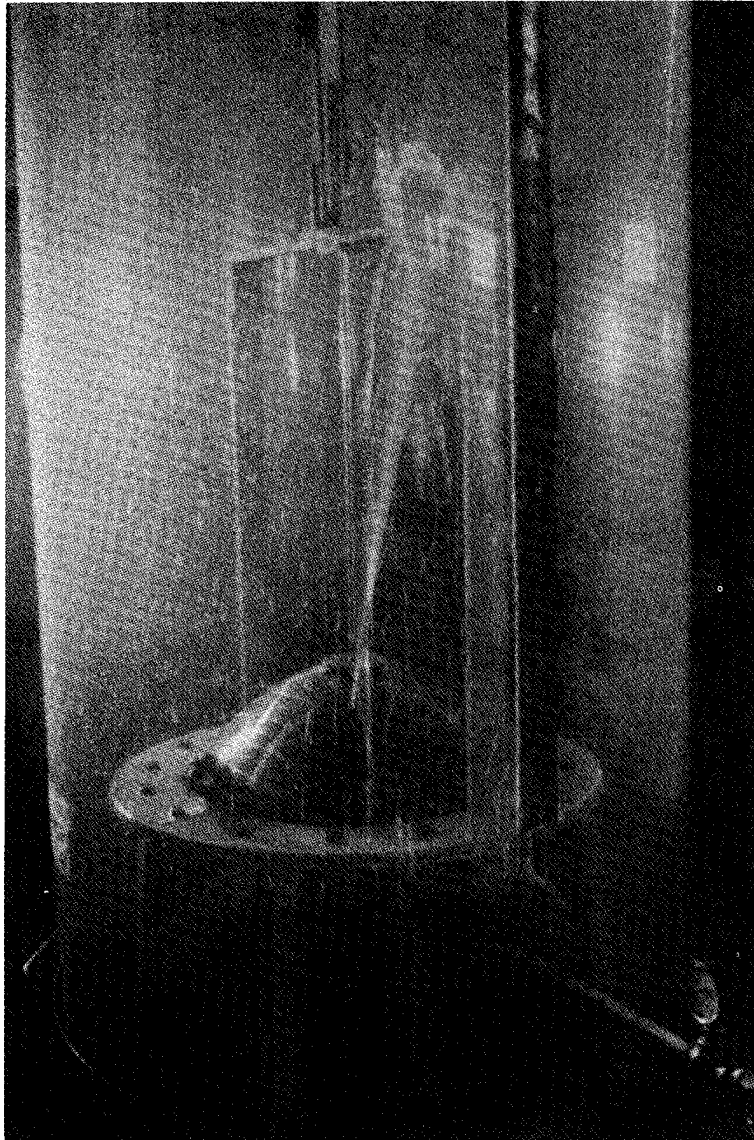

Figure 23. Burst test - HDPE at burst; off-center failure location indicates dishomogeneity

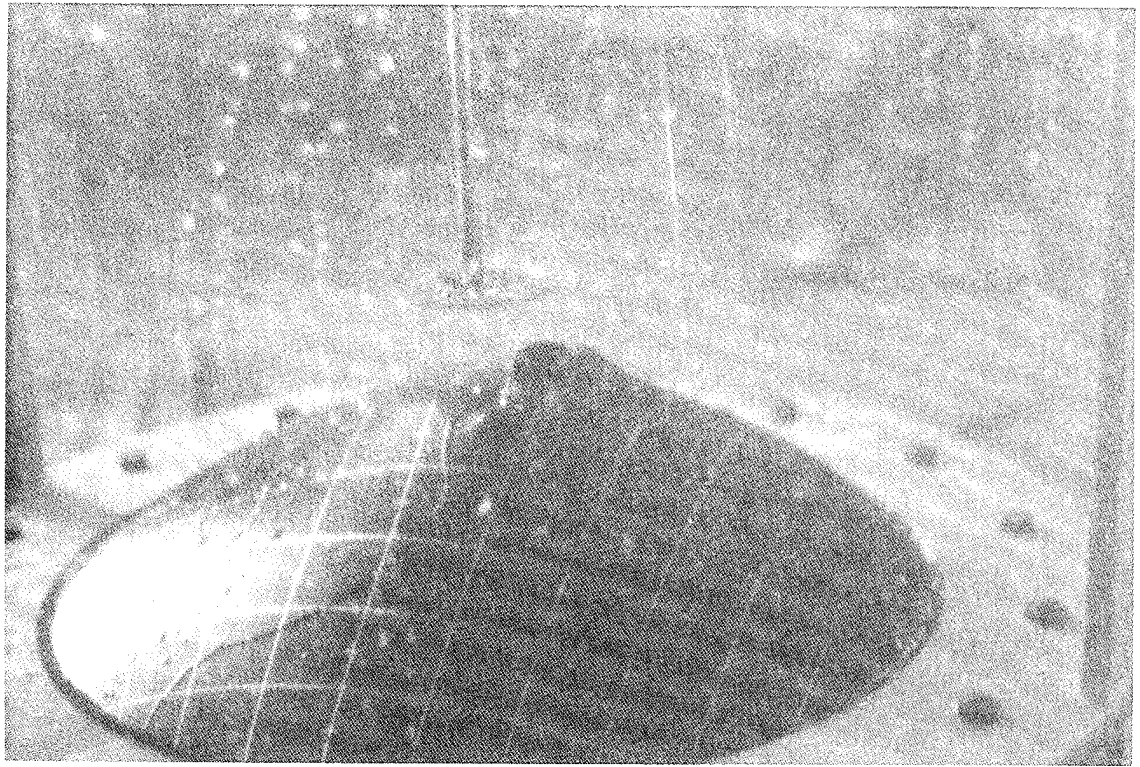

Figure 24. Burst test - HDPE after burst

Table 3 summarizes the evaluation of all multiaxial tests results. For each property, membranes have been assigned a rating varying from 1 to 5, with the following definitions for each rating.

- a.* 1 = unsatisfactory
- b.* 2 = poor
- c.* 3 = fair
- d.* 4 = good
- e.* 5 = excellent

Table 3 Multiaxial Tests Membrane Material Evaluation																					
Test 1 Multiaxial Puncture Test	PVC 1	PVC 1.5	PVC 2	PVC 2.5	PVC 1 + 200	PVC-R 1.5 + 200	PVC-R 2 + 200	PVC-R 2.5 + 500	CSPE-S 1	CSPE-S 1.2	CSPE-S 1.4	CSPE-R 0.8 + 0.4	CSPE-R 1 + 0.4	CSPE-R 1.2 + 0.4	PP-R 1.5 + 300	EPDM 2	EPDM 3	HDPE 1.5	HDPE 2	HDPE 2.5	
Conformability to substrate	5	5	5	4	5	5	5	5	5	5	5	4	4	4	5	4	4	1	1	1	
Failure at protrusions (puncture)	5	3	5	5	5	4	5	5	4	4	4	3	3	3	3	5	5	1	1	1	
Failure at depressions (burst)	3	5	5	5	4	5	5	5	3	4	4	2	2	2	4	5	5	n.a.	n.a.	n.a.	
Elastic recovery	3	3	4	5	3	4	5	5	3	3	3	1	1	1	1	5	5	n.a.	n.a.	n.a.	
Total Rating Test 1	16	16	19	19	17	18	20	20	15	16	16	10	10	10	11	13	19	19	2	2	2
Test 2																					
Burst Test																					
Homogeneity	4	5	5	5	5	5	5	5	4	4	4	1	1	1	2	4	4	1	1	1	
Isotropy	4	5	5	5	5	5	5	5	4	4	4	1	1	1	4	4	4	1	1	1	
Capability to deform	5	5	5	5	5	5	5	5	4	4	4	3	3	3	4	4	5	2	1	1	
Total Rating Test 2	13	15	15	15	15	15	15	15	12	12	12	5	5	5	10	9	13	13	4	3	3
Total Rating Tests 1 & 2	29	31	34	34	32	33	35	35	27	28	28	15	15	15	21	22	32	32	6	5	5

n.a. = not applicable due to extreme lack of conformability to substrate
Numbers indicate membrane thickness + reinforcement identification

The following observations can be made:

- a. From the point of view of puncture resistance, only one material, HDPE, did not perform well. All specimens of HDPE, notwithstanding thickness, failed. For all other materials, higher thickness provided higher resistance. Low thicknesses can therefore be critical when the subgrade is very rough.
- b. For all materials which can be reinforced, presence of reinforcement provided higher puncture resistance.
- c. Results of the burst tests correlated well with results of the puncture tests with respect to the influence of thickness and reinforcement.
- d. All materials except HDPE conformed well to substrate. Thickness of membrane appeared to have only a slight influence on conformability.
- e. Increasing the membrane thickness and adding reinforcement tended to improve elastic recovery.
- f. Some materials showed a lack of homogeneity regardless of thickness.
- g. Reinforcement generally improves not only resistance to puncture, but also improves bursting resistance and elastic recovery.

Manufacturers' data, results of standardized tests, and multiaxial test results were assembled and evaluated to provide a basis for selection of membrane materials. The information is shown in detail in Table 4 and summarized in Figure 25.

Table 4 is divided into two parts. Part A contains material properties which were mostly obtained through standardized testing, thus allowing for a quantitative comparison of materials. Part B is based primarily on qualitative multiaxial tests and experience. The relative importance of each property was assigned a weighting factor ranging from 1 to 5.

The assigned weights quantify the importance of the various membrane selection criteria for underwater installations. They usefully summarize the factors that are most important for this kind of application:

- a. Low permeability.
- b. Mechanical resistance.
- c. Flexibility, seamability, and specific gravity, i.e., constructability.
- d. References.
- e. Durability.

Table 4 Membrane Material Evaluation for Underwater Installation																	
Property	Weight	PVC		PVC-R		CSPE-S		CSPER		PP		PP-R		EPDM		HDPE	
		Rating	Score	Rating	Score	Rating	Score	Rating	Score	Rating	Score	Rating	Score	Rating	Score	Rating	Score
PART A																	
Impermeability	5	5	25	5	25	5	25	5	25	5	25	5	25	5	25	5	25
Tensile behavior	5	4	20	5	25	5	25	5	25	3	15	5	25	4	20	2	10
Tear resistance	5	3	15	5	25	5	25	5	25	3	15	4	20	5	25	4	20
Puncture resistance	5	4	20	5	25	3	15	3	15	3	15	4	20	4	20	2	10
Flexibility	5	5	25	5	25	5	25	3	15	5	25	4	20	5	25	2	10
Specific gravity	5	5	25	5	25	5	25	5	25	1	5	1	5	5	25	1	5
Seamability	4	5	20	5	20	3	12	3	12	4	16	4	16	3	12	2	8
Dimensional stability	1	4	4	5	5	5	5	4	4	4	4	4	5	4	4	3	3
Total Score A			154		175		157		146		120		136		156		91
PART B																	
Overall constructability	4	5	20	5	20	4	16	4	16	3	12	3	12	4	16	1	4
Previous applications	4	5	20	5	20	4	16	1	4	2	8	2	8	2	8	2	8
Durability	3	5	15	5	15	5	15	5	15	5	15	5	15	5	15	5	15
Availability	2	4	8	4	8	2	4	1	2	3	6	3	6	3	6	5	10
Repairability	2	5	10	5	10	4	8	4	8	3	6	3	6	3	6	1	2
Cost	2	4	8	4	8	2	4	2	4	3	6	3	6	1	2	5	10
Total Score B			81		81		63		49		53		53		53		89
Total Score A & B			235		256		220		195		173		189		209		140
Rank			2		1		3		5		7		6		4		8

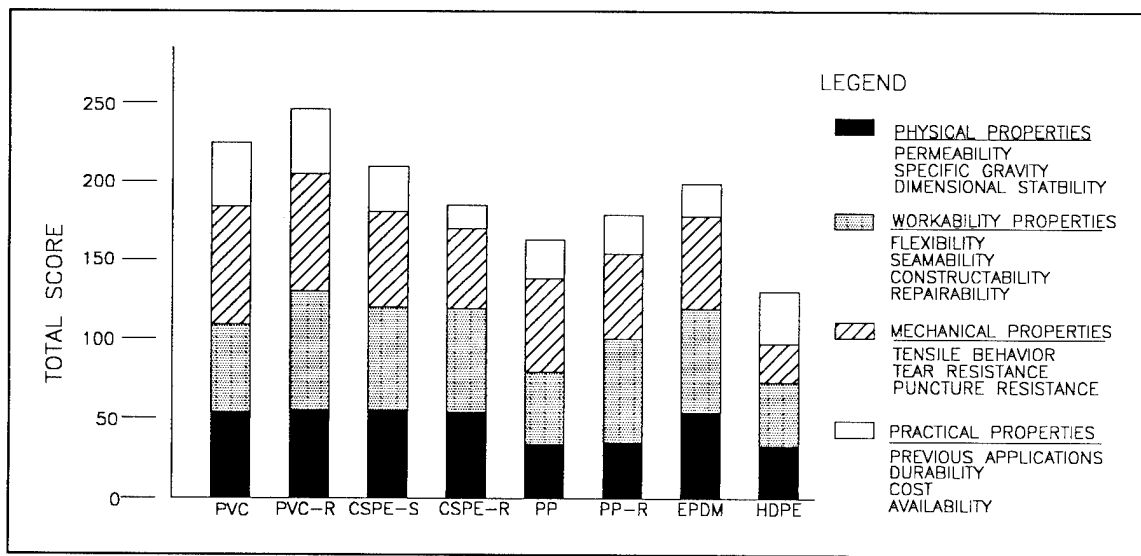

Figure 25. Membrane material evaluation for underwater installation

Results of all testing and evaluation of data summarized in Table 4 indicate reinforced PVC as the material of choice for this application. Extensive use of PVC in the field of reducing ingress of water into hydraulic structures confirm this finding, and experience shows that owners and geosynthetic applications designers feel more comfortable with more widely used materials.

Among all materials investigated, only HDPE was deemed unsuitable for this kind of application.

In an effort to validate this preliminary conclusion, the research team referred to an independent party for further analysis to determine if their results were consistent with current beliefs of recognized geosynthetic experts. In summary, the independent expert report (Appendix C) supported the findings of the research team.

The material recommended for underwater installations is a PVC geocomposite with a backing reinforcement of NW geotextile coupled to the PVC geomembrane during manufacturing. For installations with extremely severe service requirements, geocomposites with PVC thickness up to 4 mm are available.

Seismic test

The selected PVC geocomposite was subjected to large-scale seismic testing to verify reliability of the material in the case of a seismic event. The seismic test was designed to simulate instantaneous elongation of the test material similar to what would be expected of a crack suddenly opened in the concrete substrate. Behavior was recorded with respect to failure or capability of the geocomposite to withstand the elongation.

Since no standard test procedure is available, the apparatus was specially designed. The apparatus consists of a frame with a fixed and a movable part (Figure 26). The movable part is attached to the fixed part by means of a hinge. The hinge allows for rotation of the movable part to create an instantaneous gap between the two parts, thus simulating fairly well the sudden opening of an existing crack on the upstream face of a dam.

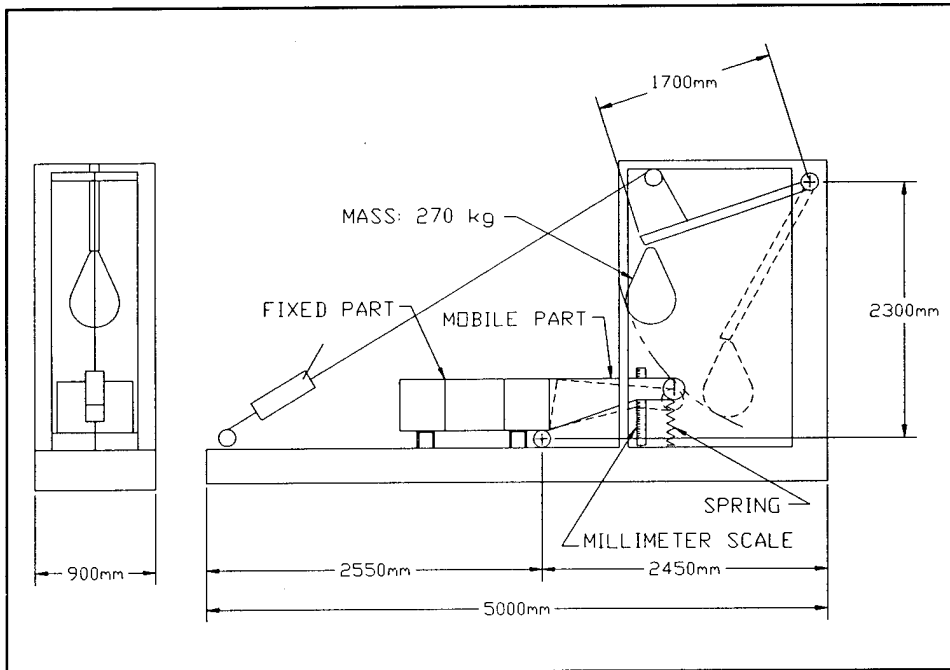

Figure 26. Seismic testing equipment

The movable part is kept in a horizontal position, next to the fixed one, by means of a return spring. The spring must restrict the opening of the “crack” during testing and return the movable part to its original position after testing. Pretensioning of the spring fixes the width of the opening.

Another essential feature of the equipment is a pendulum, consisting of a movable arm made with a rigid steel profile, hinged to the upper part of a portal connected to the fixed frame, and of a cast iron sphere, having a mass of 270 kg. The sphere can be raised by means of a small winch connected to a device for automatic release of the ball itself. When the sphere hits the rounded edge of the movable part of the system, its momentum creates the sudden opening of a “crack,” thus causing rapid elongation of the membrane. As this occurs very rapidly, measurements are made by recording the test with a camera which films the millimetre scale positioned near the movable section hit by the pendulum. Reviewing the recorded film in slow motion allows reading of the maximum downward motion of the movable part. A simple mathematical formula gives the corresponding rapid elongation on the tested sample.

The upper side of the equipment is 650 mm wide. The geomembrane is anchored laterally by metal profiles and bolts and pretensioned in the middle by the SIBELON SYSTEMS coupled profiles.

Testing was performed on a geocomposite consisting of a 2.5-mm PVC geomembrane, coupled during manufacturing to a pure polyester geotextile with a unit mass of 500 g/m². The purpose of the test was to determine if the geocomposite could withstand a sudden 15-mm elongation without failure. Testing simulated increasing openings up to 36 mm and no failure occurred.

Summary

The membrane material characteristics suitable for underwater installation must be carefully considered and evaluated. Large-scale testing is highly recommended to investigate actual behavior in service life. A membrane with backing reinforcement and with prior use is preferred. The material of choice at present is PVC with backing reinforcement.

Mechanical Fastening

Mechanical fastening components are those components which secure and seal the membrane to the surface of the hydraulic structure. Anchor bolts, profiles, and gaskets serve this function.

Anchor bolts

Anchor bolts secure the profiles to the surface of the structure. The selection criteria for anchor bolts are the ability to withstand tensile and torsional loading (i.e., mechanical performance) and the ease of installation. Ease of installation is a combination of the time and effort required for installation and the level of workmanship standards required for quality assurance.

A survey was conducted of available anchor bolts. Five types were selected for physical testing:

Two-part epoxy—A chemical anchor that embeds a threaded dowel in the hardened concrete. The epoxy hardens after a resin is mixed with a filler material.

Encapsulated resin and epoxy filler—An encapsulated resin anchor used in combination with an epoxy filler. The epoxy filler is used to help displace water from the anchor-bolt hole to improve the efficiency of the encapsulated resin.

Encapsulated resin—A chemical anchor with adhesive prepackaged in a glass capsule.

Impact set—A mechanical anchor which is secured by driving an expansion pin through the anchor bolt. The pin expands a portion of the anchor bolt, seating it in the concrete.

Torque set—A mechanical anchor which is secured by applying a specified torque to the anchor bolt nut. As the nut is tightened, a wedge action permanently seats the bolt in the concrete.

A test method was designed to provide a means of evaluating the pullout resistance and torque resistance of anchor bolts installed into concrete underwater. It allowed comparison of the mechanical performance characteristics of various available anchor bolts with respect to the underwater installation of a membrane.

The test method used a test specimen installed underwater into a flat concrete slab. A tensile load of up to 5,500 lb (force) was gradually applied to the anchor. The anchor bolt was observed visually for pullout failure. If no pullout was observed, the tensile load was removed and a washer and nut were installed. The torque load was applied until either the bond with the concrete was broken allowing the anchor to rotate or until the bolt failed in torsion.

A flat concrete slab with a minimum thickness of 10 in. and a minimum compressive strength of 4,000 psi was constructed. A loading device was used to apply and measure an accurate tensile load of up to 5,500 lb (force). Figure 27 illustrates this device. A hand torque wrench was used to apply to torque load of up to 200 lb (force).

Specimens were 1/2-in.-diam off-the-shelf anchor bolts which permitted 5-in. embedment depth. Three samples of 10 anchor bolts were tested. The bolts tested are outlined in Table 5.

The following procedures were followed to install the various anchor bolts:

Two-part epoxy

- a. Drill a 9/16-in.-diam hole 5 in. deep into the concrete.
- b. Clean hole three times by flooding diver's auxiliary air supply hose and injecting water into the hole.
- c. Insert plastic containment cover into hole.
- d. Insert epoxy gun nozzle into hole so end of nozzle touches bottom of drilled hole.

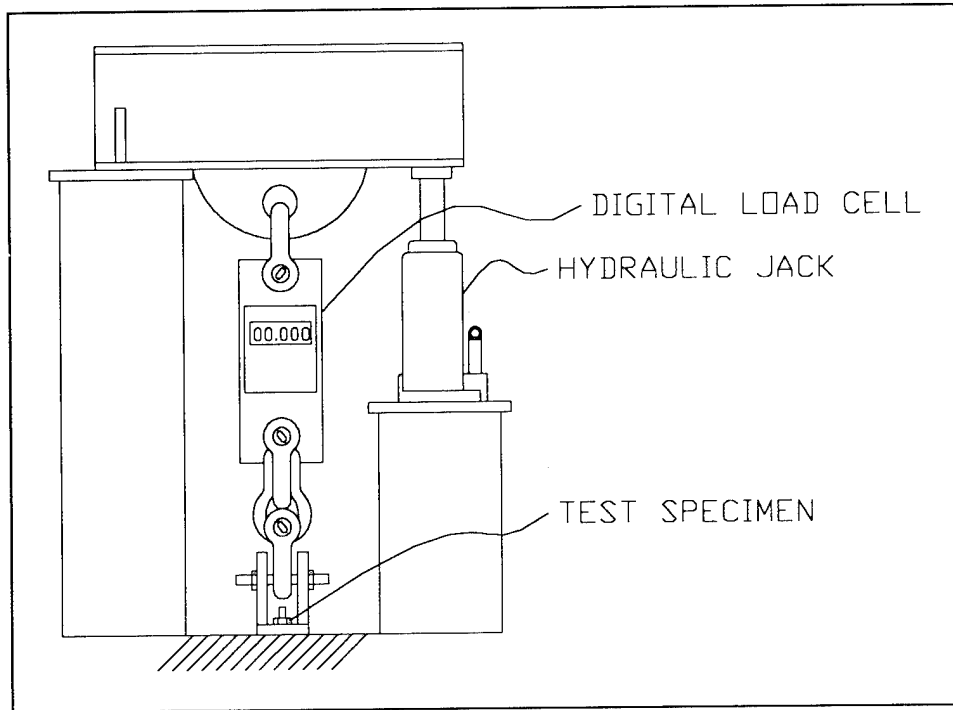

Figure 27. Anchor bolt pullout test equipment

Table 5 Anchor Bolts Tested			
Number	Type	Category	Product Brand
1	Two-part epoxy	Chemical	HILTI HIT C-100
2	Encapsulated resin & filler	Chemical	HILTI HEA capsule & HIT-100 filler
3	Encapsulated resin	Chemical	HILTI HEA
4	Two-part epoxy	Chemical	Ramset ceramic 6
5	Two-part epoxy	Chemical	Rawl foil fast (slow set)
6	Two-part epoxy	Chemical	Rawl foil fast (fast set)
7	Impact set	Mechanical	All-American
8	Torque set	Mechanical	ITW ramset/readhead
9	Torque set	Mechanical	HILTI-Kwik bolt II
10	Torque set	Mechanical	Rawl

- e. Inject epoxy into hole while slowly extracting nozzle. Fill hole up to plastic containment cap.

- f.* Push 1/2-in.-diam stainless steel threaded dowel into hole. Allow excess epoxy to flow from hole. After dowel is bottomed out in hole, clean off excess epoxy.
- g.* Keep specimen underwater for 48-hr cure time.

Encapsulated resin and filler

- a.* Drill a 9/16-in.-diam hole 5 in. deep into the concrete.
- b.* Clean hole three times by flooding diver's auxiliary air supply hose and injecting water into the hole.
- c.* Insert plastic containment cover into hole.
- d.* Insert filler gun nozzle into hole so end of nozzle touches bottom of drilled hole.
- e.* Inject filler into hole while slowly extracting nozzle. Fill hole to plastic containment cap.
- f.* Insert glass capsule into hole.
- g.* Insert stainless-steel threaded dowel into hole.
- h.* Screw two nuts on to the exposed end of the dowel (with a washer between the two nuts).
- i.* Crush glass capsule and drive dowel to bottom of hole using a rotary hammer drill.

Encapsulated resin

- a.* Drill a 9/16-in.-diam hole 5 in. deep into the concrete.
- b.* Clean hole three times by flooding diver's auxiliary air supply hose and injecting water into the hole.
- c.* Insert plastic containment cover into hole.
- d.* Insert glass capsule into hole.
- e.* Insert stainless-steel threaded dowel into hole.
- f.* Screw two nuts on to the exposed end of the dowel (with a washer between the two nuts).

- g.* Crush glass capsule and drive dowel to bottom of hole using a rotary hammer drill.

Impact set

- a.* Drill a 1/2-in.-diam hole 5 in. deep into the concrete.
- b.* Clean hole three times by flooding diver's auxiliary air supply hose and injecting water into the hole.
- c.* Insert anchor bolt into hole (tap into place with hammer if necessary).
- d.* Insert expansion pin and hammer until pin head is flush with end of anchor bolt.
- e.* Keep specimen underwater for 48-hr cure.

Torque set

- a.* Drill a 1/2-in.-diam hole 5 in. deep into the concrete.
- b.* Clean hole three times by flooding diver's auxiliary air supply hose and injecting water into the hole.
- c.* Insert anchor bolt into hole (tap into place with hammer if necessary).
- d.* Install washer and nut.
- e.* Apply specified torque to anchor bolt.

The anchor bolt test results are outlined in Table 6.

Testing revealed no substantial difference between different brands of the same type of anchor. Additionally, there was no substantial difference in pullout and torque resistance between torque-set anchors, two-part epoxy anchors, and encapsulated resin with epoxy filler (types 1, 3, and 5). Encapsulated resin and impact anchors scored lower. Experience acquired in the field and during this testing showed that mechanical performance of chemical anchors is very much dependent on installation procedures and workmanship. Chemical anchors can be installed underwater with similar effectiveness to those installed in the dry if specific precautions are taken. The water must be displaced from the hole to allow a homogeneous layer of resin to bond to the bolt and the concrete. Mechanical anchors can be easily and successfully installed underwater. Typical results of pullout tests are shown in Figures 28 through 30. The performance analysis of the various anchor bolts tested are summarized in Table 7.

Table 6 Anchor Bolt Test Results		
Bolt	Mean Pullout Resistance (pounds force)	Mean Torque Resistance (foot pounds force)
1	> 5,500	> 150
2	> 5,500	> 150 (steel failed)
3	4,300	120 (resin failed)
4	> 5,500	> 150
5	> 5,500	135 (steel failed)
6	> 5,500	135 (steel failed)
7	1,400	Not tested due to pullout failure
8	> 5,500 ¹	> 150
9	> 5,500 ¹	> 150
10	> 5,500 ¹	> 150

¹ Slight displacement (approximately 1/8 to 3/16 in.) during initial loading.



Figure 28. Steel fails before epoxy on encapsulated resin with epoxy filler anchor

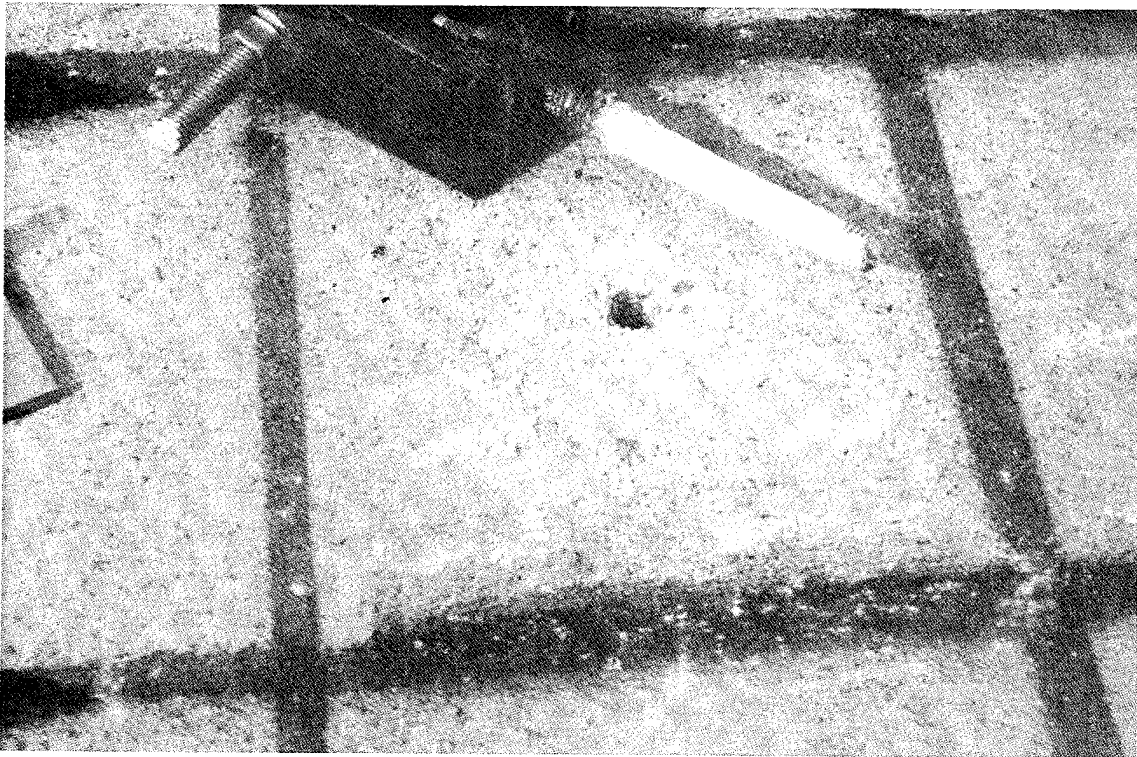

Figure 29. Pullout failure of encapsulated resin anchor



Figure 30. Pullout failure of impact set anchor. The anchor displaced approximately 1/4 in. and then the steel failed in tension

Table 7 Performance Analysis						
	Mechanical Performance Weight = 5		Ease on Installation Weight = 4		Total Score	Rank
	Rating	Score	Rating	Score		
Two-Part Epoxy	5	25	2	8	33	3
Encapsulated Resin with Epoxy Filler	5	25	3	12	37	2
Encapsulated Resin	3	15	4	16	31	4
Impact Set	2	10	3	12	22	5
Torque Set	5	25	5	20	45	1

Perimeter profiles and gaskets

The perimeter profiles secure the membrane to the structure along its perimeter. Steps to reduce ingress of water are accomplished by compressing the perimeter profile against a gasket which forms a seal between the membrane and the surface of the hydraulic structure.

The profile material must resist corrosion while submerged. Stainless steel has performed well in field applications. It may be necessary to specify a specific grade of stainless steel if there is an abnormal chemical content in the reservoir (e.g., high chloride content). The profile configuration must be such to guarantee a good balance between flexibility and stiffness. Flexibility is desirable to accommodate undulations and roughness, while stiffness is desirable to minimize the number of required anchor points. A flat bar configuration was chosen. Three thicknesses were selected for testing as detailed in Figure 31. Bars, 8 ft long, which were considered a reasonable length for underwater handling, were used in the testing.

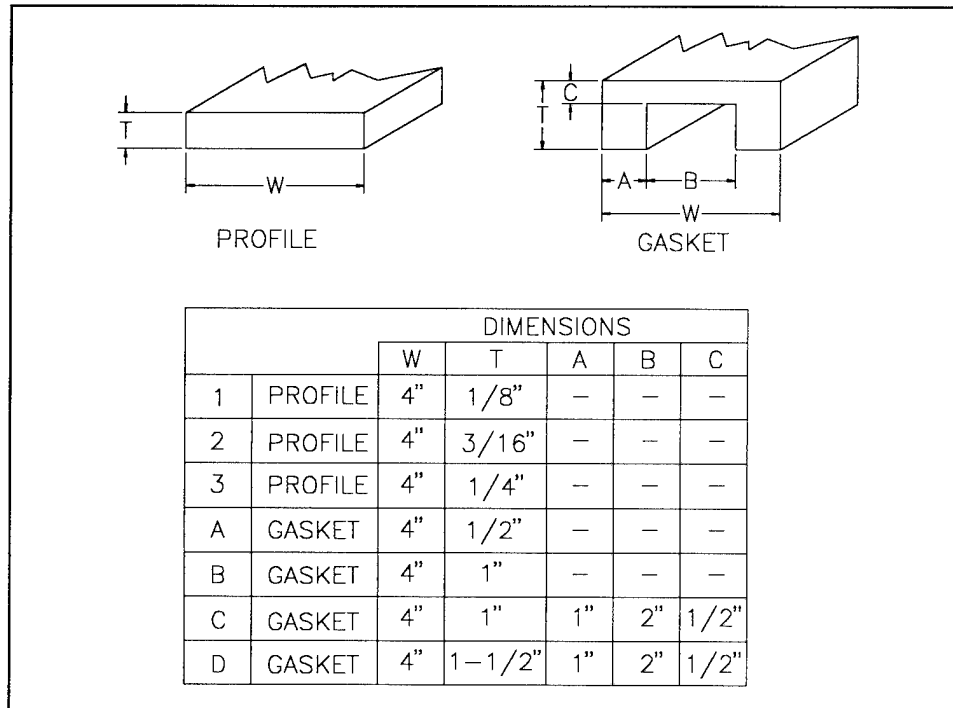

Figure 31. Illustration of profiles and gaskets

The gasket material must be durable and resistant to environmental conditions. It must be flexible and compressible. Furthermore, it must remain elastic under compression and must withstand a pressure differential. The magnitude of the required pressure differential capability is dependent on the maximum water depth of the repair and whether or not the repair is for a drained system. In the case of a drained system, the required pressure differential capability is a function of the water depth of the repair. This criterion will vary from site to site.

Solid rubber gaskets are probably the most commonly used gasket material for membrane perimeters. Compared to an expanded rubber, however, solid gaskets are less reliable in accommodating the surface roughness likely to be encountered during an underwater installation due to lower conformability.

Expanded rubber is available in two basic forms, closed cell and open cell. Closed-cell gaskets have good conformability in shallow water, but performance degrades under considerable hydrostatic head. Open-cell gasket material will not compact under hydrostatic pressure, thus remaining compressible and flexible so that it can conform to even a rough surface. This, and successful experience with the material, were the first reasons the research team believed that open-cell neoprene could be the material of choice. Additional considerations in favor of open-cell neoprene came from torque specifications required to seat torque-set anchors. Seating torque-set anchors will cause high levels of gasket compression.

High compression of a solid rubber gasket can cause the gasket to lose its resiliency and its ability to maintain an effective seal (Well 1993). The research team's experience with open-cell material has revealed its high resiliency properties. This experience, however, is primarily based on short-term applications (seals compressed for periods of several hours, not several years). Testing to determine the long-term effects of compressed open cell neoprene was deemed necessary.

Two basic gaskets were selected for testing; a flat strip and a channel-section strip.

The channel-section gasket candidates were designed with the intent that:

- a. A smaller force would be required to compress the flanges to a minimum required compression deflection, thereby allowing a more flexible profile or greater bolt spacing.
- b. Should the gasket be compressed excessively, the web will not see the full compression and will remain elastic under greater loads.

The second test of gaskets and profiles aimed to verify the effect of bolt spacing on the seal efficiency. Testing was performed by installing various profile and gasket configurations on a flat concrete slab and measuring the compression of the gasket on its entire length as bolt spacing was changed.

Gasket and profile conformability test

Testing was conducted to ascertain the ability of a gasket and profile combination to conform to an irregular substrate. The test was designed to compare various profile and gasket combinations secured to a concrete surface to provide rudimentary design optimization for perimeter anchorage and splice joints for underwater membrane installation.

Testing was accomplished by securing a candidate profile and gasket combination to a concrete slab with anchor bolts. The concrete slab was constructed with a surface simulating an undulation likely to be encountered underwater on a concrete hydraulic structure (Figure 32).

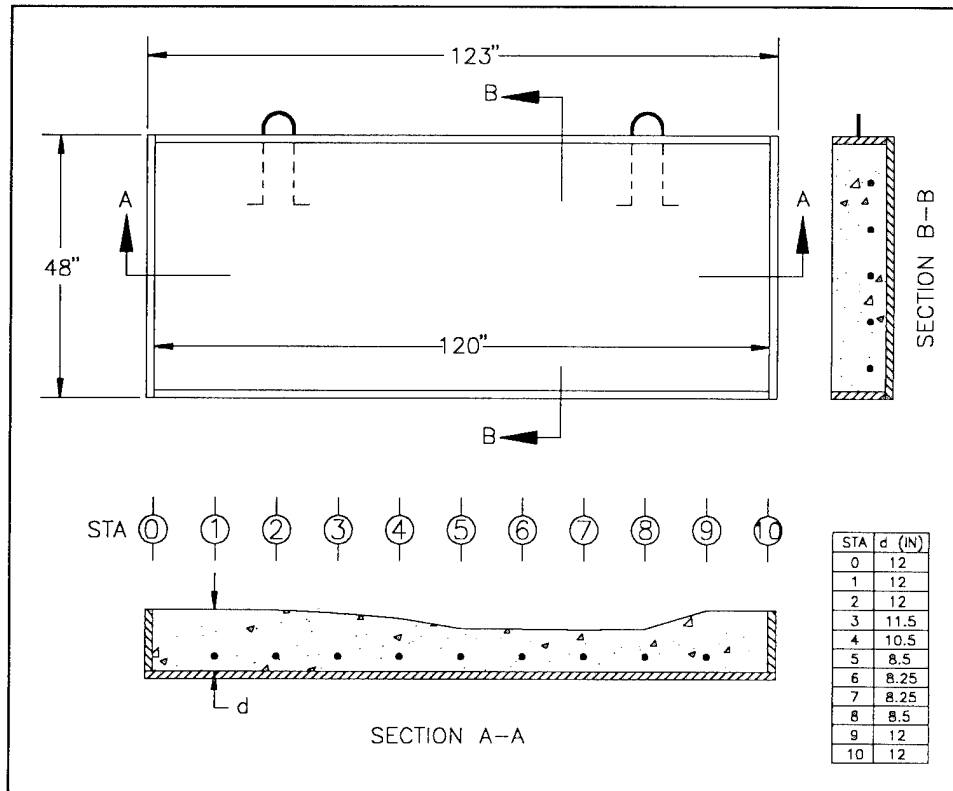

Figure 32. Concrete test slab details for profile/gasket conformability test

Profile and gasket test specimens were 4 in. wide and 8 in. long with 3/4-in. holes spaced every 12 in. along the length. All profiles were stainless steel, and all gaskets were medium hardness open-cell neoprene. Three profile candidates (1, 2, and 3 in Figure 31) were tested with four gasket candidates (A, B, C, and D in Figure 31) in all 12 possible combinations.

The test was conducted by placing the gasket and profile on the test slab. The end anchor-bolts and the anchor-bolt midspan of the depression were tightened to 60 ft-lbf. The gasket compression was measured along the length of the profile. If at any point the gasket compression was less than 50-percent compression deflection, additional anchor bolts were tightened.

Compression deflection was determined by applying the following formula:

$$C = \frac{(A_o - A_c)}{A_o} \times 100$$

where:

- C = Compression deflection, %
- A_o = Original thickness, in.
- A_c = Compressed thickness, in.

General notes on candidate combinations of profiles and gaskets were recorded. The testing revealed that the combinations with channel-section gaskets provided better conformability to the undulation. Performance of gasket candidates C and D was virtually identical with respect to conformance to the substrate. Gasket D, however, exhibited irregular deformation at the anchor-bolt locations. The testing also revealed that even the thickest profile was able to flex sufficiently to follow the general shape of the slab. Figure 33 is a photograph of a combination of profile 3 and gasket B.

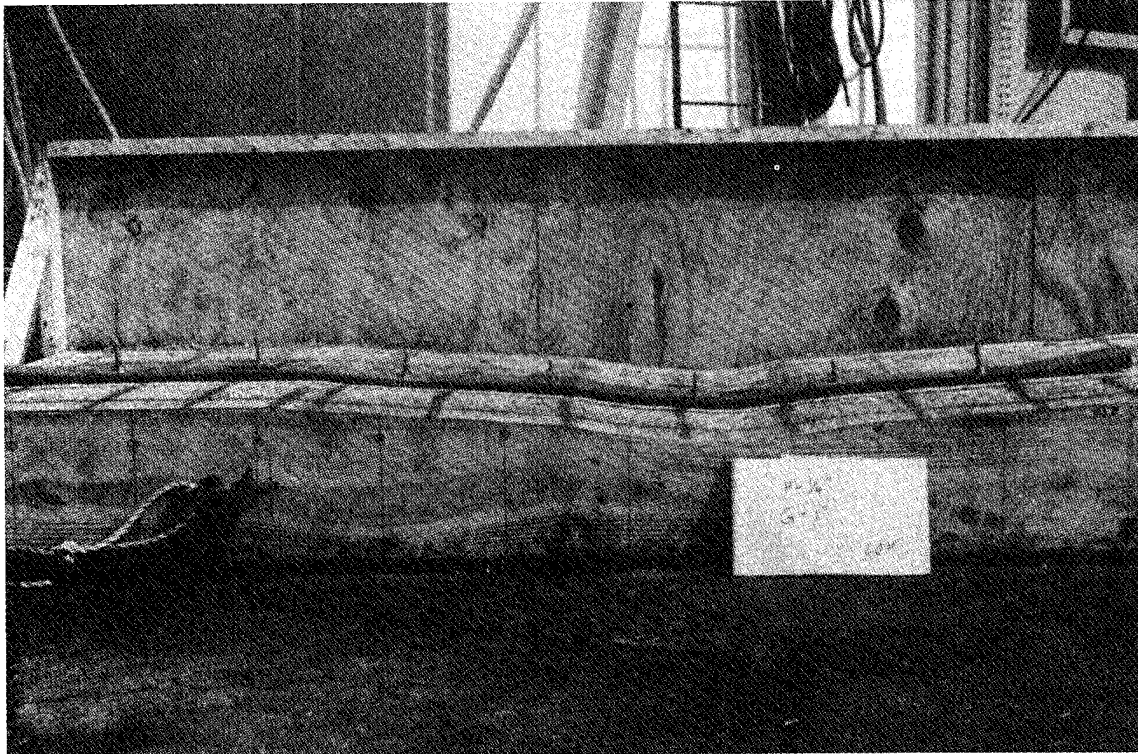

Figure 33. Profile and gasket conformability test: 1-in.-thick, open-cell neoprene gasket compressed by a 1/4-in.-thick stainless steel profile with 12-in. anchor-bolt spacing

Profile stiffness test

While profile flexibility is necessary to conform to the substrate, a certain amount of stiffness is required to ensure continuous gasket compression without an excessive number of anchor bolts. Testing was conducted to determine which profiles were suitable for installation with the selected gasket candidate.

Testing was accomplished with a candidate profile to compress the selected gasket against a flat concrete slab. Anchor-bolt spacing was varied to determine the effect on uniformity of gasket compression. The test specimens

were stainless steel profiles identical to the ones used for the gasket/profile conformability test.

Testing consisted of placing the candidate profile over the gasket on the concrete slab. Anchor bolts were tightened through the end holes of the profile to 60 ft-lbf. The gasket compression was measured along the length of the profile. If at any point the gasket compression was less than 50-percent compression deflection, anchor bolt spacing was reduced by tightening an additional anchor bolt through the hole closest to midspan. The process of adding anchor bolts was repeated until bolt spacing was reduced to 12 in.

Testing confirmed the importance of gasket stiffness. Using continuous 50-percent compression deflection as the acceptance criteria, profile candidates 1 and 2 performed satisfactorily with 24-in. anchor-bolt spacing. The photographs of the 1/4-in.-thick profile (Figure 34) and the 1/8-in.-thick profile (Figure 35) illustrate the difference in stiffness and the effect on gasket compression.

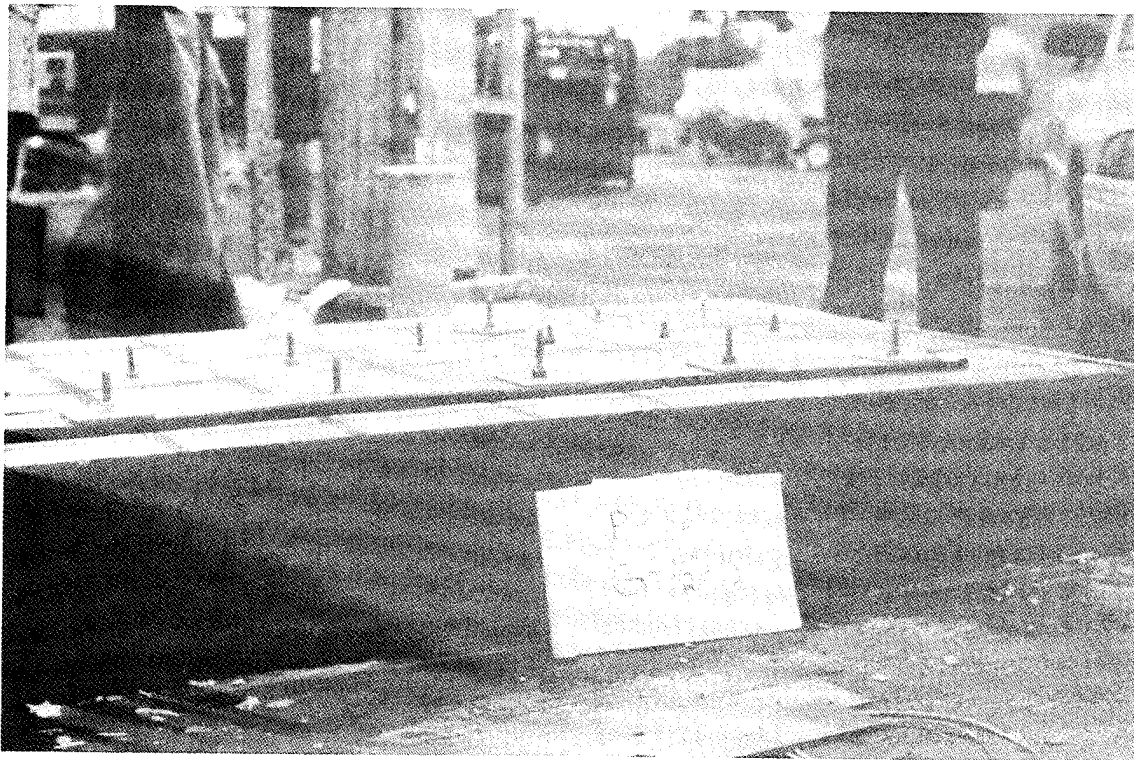

Figure 34. Stainless steel profile, 1/4-in.-thick, compressing channel-shaped, open-cell neoprene gasket

pressure differential across the specimen is created by regulating the flow of compressed air into a testing apparatus. Leakage is detected by applying a solution of soap and water and making visual observations.

A testing device was constructed for this purpose. The device consisted of a gasket compression device and a means of applying a pressure differential. A set of force application bolts and two parallel plates comprised the compression device. One plate had a fitting suitable to plumb compressed air through. A source of compressed air with a suitable regulator to control the pressure at a point between 0 and 100 psi was used to pressurize the specimen. Figure 36 contains an illustration of the testing apparatus.

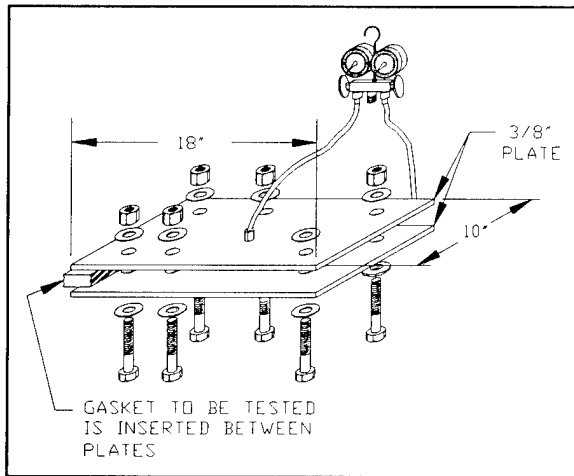

Figure 36. Apparatus for gasket pressure test

Testing was conducted by placing the gasket into the compression device. The gasket was laid flat around the perimeter of the bottom plate. Two lengths of gasket material were butted together at a bolt location to simulate the juncture of two lengths of gasket on the perimeter anchorage of a membrane. The force application bolts were tightened evenly until the compression deflection was achieved for the respective data point. The

compression deflection was varied from 20 to 80 percent at 10-percent intervals. A thin layer of the soap and water solution was sprayed on the exposed portions of the gasket and on the force application bolts. The apparatus was pressurized at a rate of approximately 1 psi/s until leakage was visually observed or until 100 psi was attained. A hydrostatic head of approximately 230 ft corresponds to 100 psi.

Testing revealed that failure first occurs where corners are made by simply squaring the end of one gasket piece against the edge of another. Custom designed corners could be designed to eliminate this occurrence. The graph shown in Figure 37 presents the results of the testing.

Gasket compression test

As mentioned earlier, it is important that a gasket retain its elastic properties to ensure long-term sealing efficiency. A test was designed to determine the suitability of the selected gasket with respect to elastic recovery by simulating the conditions of an actual underwater membrane installation.

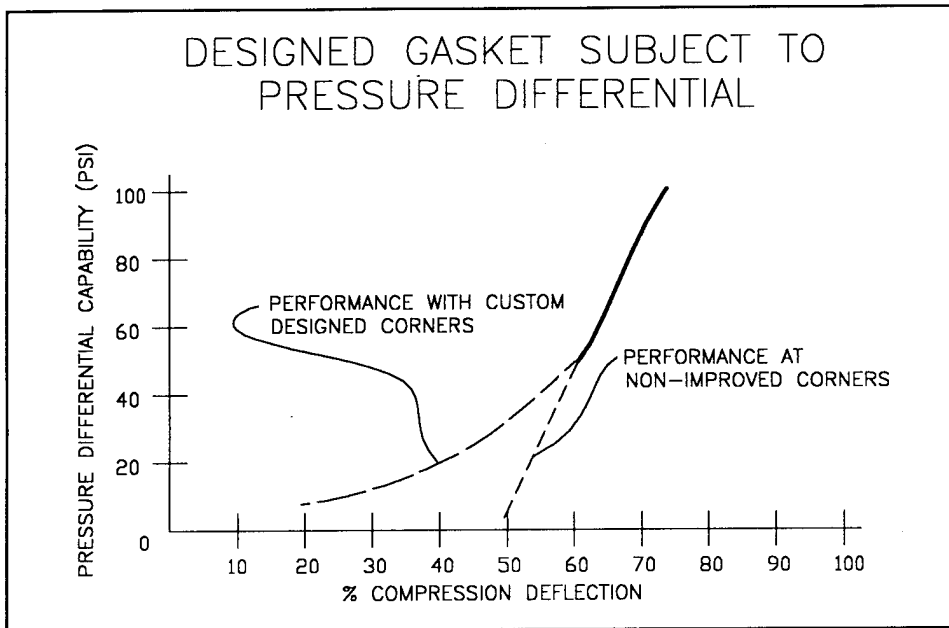

Figure 37. Pressure differential versus compression deflection in gasket pressure test

Specimens were submerged in water and compressed to a deflection of 80 percent which was the compression achieved by applying 60 ft-lbf during the profile stiffness test. The gasket specimens were kept under compression for a specified duration. The durations of compression loading were 7, 14, 28, 56, 112, and 224 days. At the end of the loading period, the compressive load was relieved and elastic recovery was measured after a 24-hr recovery period.

The compression device used for the test consisted of a force application bolt and two parallel plates. Figure 38 illustrates the apparatus.

The test specimens were 5-in. lengths of 4-in.-wide gasket. Testing was conducted by submerging the specimen in water and squeezing the gasket to facilitate water infiltration into the voids. The specimen was removed from the water and placed into the compression device. The compression application bolt was tightened until 80-percent compression deflection was achieved, and

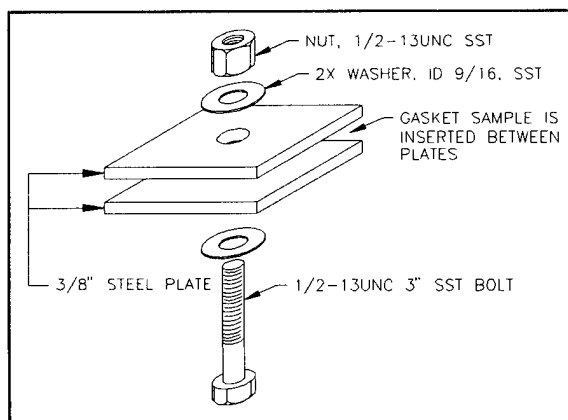

Figure 38. Gasket compression device

the test apparatus and specimen were submerged underwater. Each specimen remained submerged for its specified compression duration. At the end of loading period, the specimen was removed from the water and the compression was relieved. The thickness of the gasket was measured at the flange and at the web after a 24-hr recovery period.

Elastic recovery was determined by applying the following formula:

$$R = \left(1 - \frac{A_o - A_r}{A_o - A_c}\right) \times 100$$

where:

- R = Recovery, %
- A_o = Original thickness, in.
- A_c = Compressed thickness, in.
- A_r = Thickness after recovery period, in.

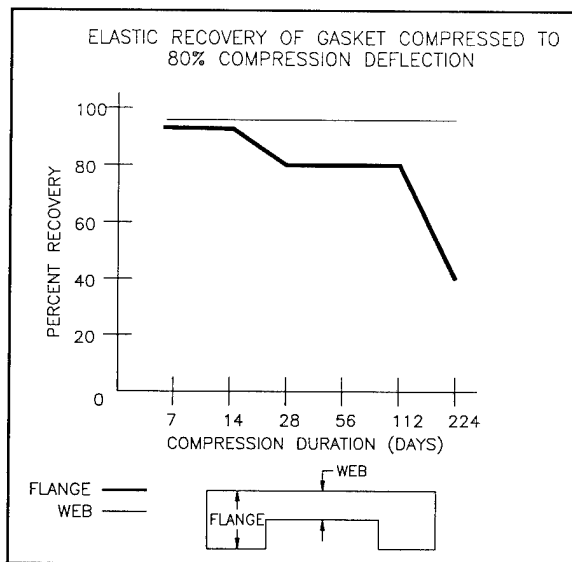

Figure 39. Results of gasket compression test

Testing to date confirms the elastic behavior of open-cell neoprene. Coupons to be relieved at 112 and 224 days are still under pressure. Data collected suggest there is some loss of elasticity in the flange area. Loss of elasticity in the web section is minimal. The graph shown in Figure 39 presents the results of the elastic recovery test.

Vertical splice joint profiles and seals

For large repairs, more than one sheet of membrane will be needed to cover the concrete surface, and therefore watertight junctions between sheets will be necessary. Presently, welding a membrane underwater is not deemed feasible on an industrial scale. Therefore, mechanical junctions are necessary.

In dry installations, mechanical junctions have been successfully achieved with special profiles designed by SIBELON that also provide pretensioning and drainage. This system can be adapted to underwater installation, or mechanical fastening can be achieved by means of two superimposed stainless

steel flat profiles compressing three open-cell neoprene gaskets and the overlapping membrane sheets.

Concrete Surface Preparation

Underwater installation should be accomplished with as little surface preparation as possible. However, preparation of the subgrade to some extent may be necessary. Alternatives are either surface preparation compounds or the installation of an additional geotextile.

Surface preparation compounds are materials that are meant to repair excessively damaged areas by adhering to the surface and forming a smoother layer. The problem with underwater installations is that the water inhibits adhesion and decreases workability.

A survey was conducted to identify available materials. Four underwater epoxy products were identified, and three of the products were tested underwater (one was not reputed to be reliable because it partly decomposed underwater).

Required characteristics for the surface repair compound are adherence to the surface, maintenance of integrity during application, workability, and pot life. Testing was conducted at the Oceaneering Morgan City facility and by SIBELON on an installation on a dam in Portugal. The various compounds were tested by applying the compounds with a spatula to spread the material on the concrete surface. Figure 40 is a photograph of a diver applying a repair compound to a concrete surface. An alternate method of spreading the compound on a polyethylene sheet on the surface, transporting the sheet underwater to the repair area, spreading the sheet against the repair surface, and working the epoxy into the defect was also evaluated. Individual observation accounted for results. The spatula method was determined to be superior.

Of the three products tested, Underwater Gel by Schull performed best and was chosen as the best epoxy. The following weighted table, Table 8, presents the data supporting this decision.

As an alternative to these compounds, additional antipuncturing layers are available on the market, and the geosynthetic industry has investigated which type and thicknesses are most suitable for any type of surface. Experience has shown that polyester or polypropylene, woven or nonwoven can be reliable materials. Choice of material type and thickness is site specific.

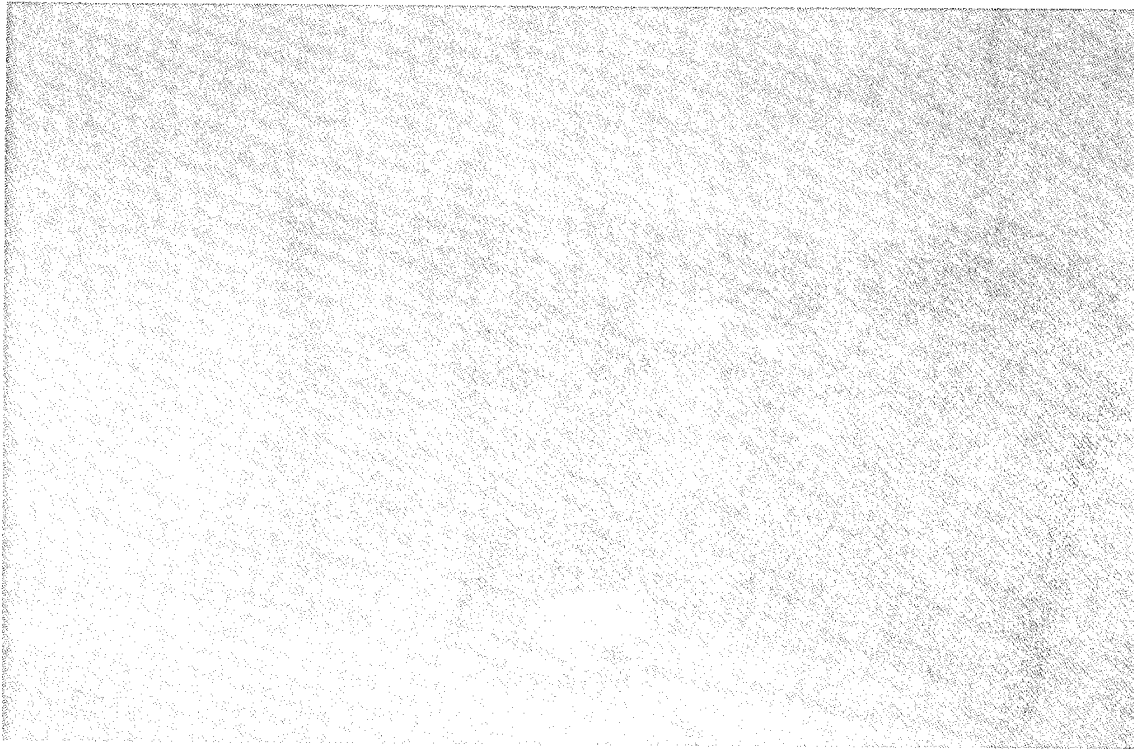

Figure 40. Underwater application of concrete repair compound

Table 8 Epoxy Comparison Results								
	Surface Adherence Weight = 5		Integrity Weight = 3		Pot Life Weight = 3		Score	Rank
	Rating	Score	Rating	Score	Rating	Score		
Devcon	3	15	3	9	3	9	33	2
Sikadur 36	2	10	1	3	2	6	19	3
Schull	4	20	4	12	3	9	41	1

Score: 1 - 5; 5 being most desirable
Weight: 1 - 5; 5 being most important

4 Discussion

A membrane system suitable for underwater installation is described in the following section.

Components

A PVC geocomposite consisting of a geomembrane backed with NW geotextile reinforcement was selected over the other available membrane materials because of its superior qualities with respect to constructability, mechanical performance, durability, and prior use. Thickness should be a site-specific design detail after careful evaluation of the surface conditions of the structure facing to be repaired. Generally, the following geocomposites will be suitable for underwater repairs on hydraulic structures. Thicker membranes will be required for more severe substrate irregularities.

<u>PVC</u>	<u>NW Geotextile</u>
2.0 mm	0.2 kg/m ²
2.5 mm	0.5 kg/m ²

HDPE geonet with preferential flow is a suitable drainage medium behind the membrane should a drained system be installed. HDPE geonet could also be specified, site specific, on an undrained system to offset the membrane from areas with excessive cracking to protect the membrane from being sucked into the cracks at installation. The drained water can be discharged downstream through the structure, or directly into the reservoir. Design of the discharge system must be based on specific site conditions.

Stainless steel anchor bolts will secure the perimeter profiles and vertical splice profiles to the concrete structure. Torque-set mechanical expansion anchors offer the best combination of functionality and installability. If bolt spacing is reduced to less than 12 in. because of site-specific concerns, chemical anchors may be required to avoid over stressing the concrete. If chemical anchors are used, installation procedures must include measures to ensure effective displacement of water from the anchor holes. Either a two-part epoxy or an epoxy/encapsulated resin compound should be used. For

both mechanical and chemical anchors, 1/2-in. anchor bolts with 5 in. of embedment are suitable for general conditions.

Stainless steel flat bar profile sections will be secured to the structure by the anchor bolts. The thickness of the profile and the configuration of the gasket should be reviewed and possibly modified on a site-by-site basis. As a general guideline, the profile should be at least 1/4 in. thick. Unless site-specific conditions dictate otherwise, the gasket should be open-cell neoprene, medium hardness, with a channel-shaped cross section.

Concerning surface preparation, the decision to use an epoxy compound or a thicker geotextile as a transition layer is site specific. Underwater Gel, manufactured by Schull, is a suitable underwater repair compound.

System

The membrane system would provide anchorage of the membrane to the substrate with a perimeter seal and with vertical splices. Such a system is shown in Figure 41.

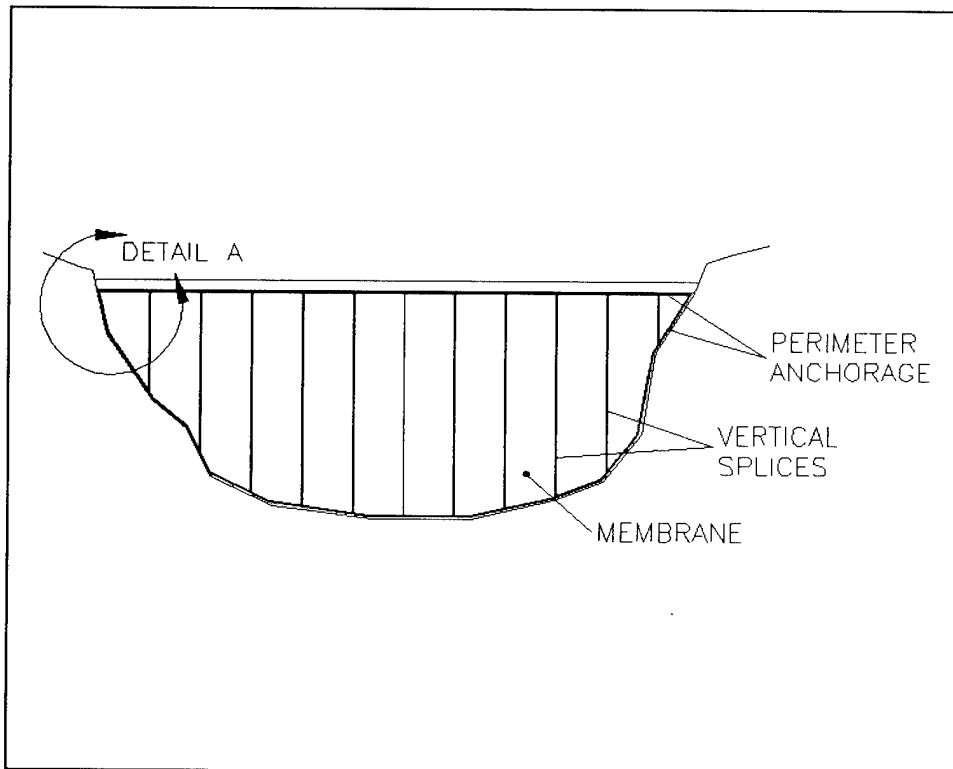

Figure 41. System general scheme

Assembly of the drainage layer and membrane and details of perimeter anchorage, are shown in Figure 42.

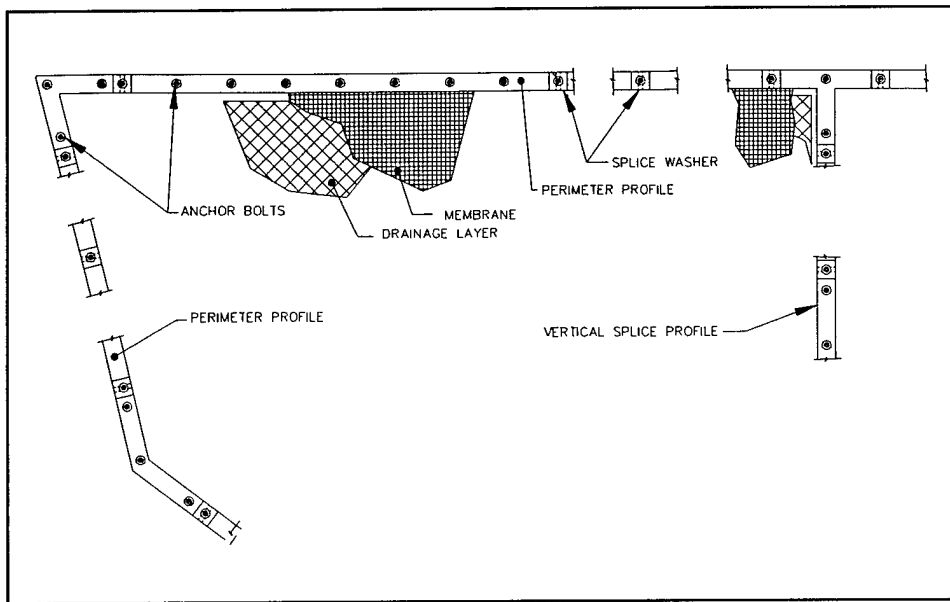

Figure 42. Assembly detail A from general scheme (Figure 41)

The perimeter seal must prevent water from penetrating the repair area. Details are shown in Figure 43.

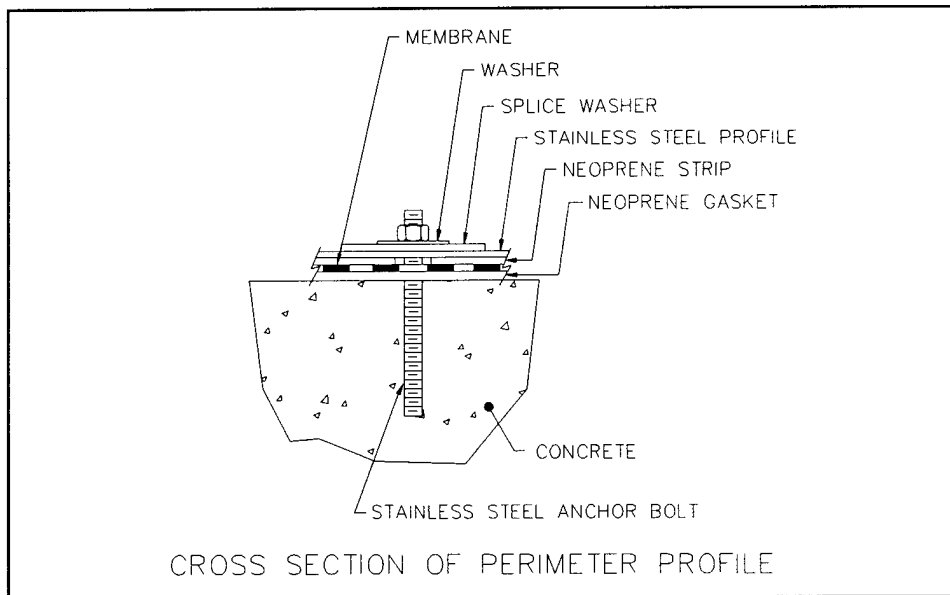

Figure 43. Perimeter seal

Vertical splices must connect membrane sheets, anchor them to the structure surface, and prevent water infiltration. A typical detail is shown in Figure 44.

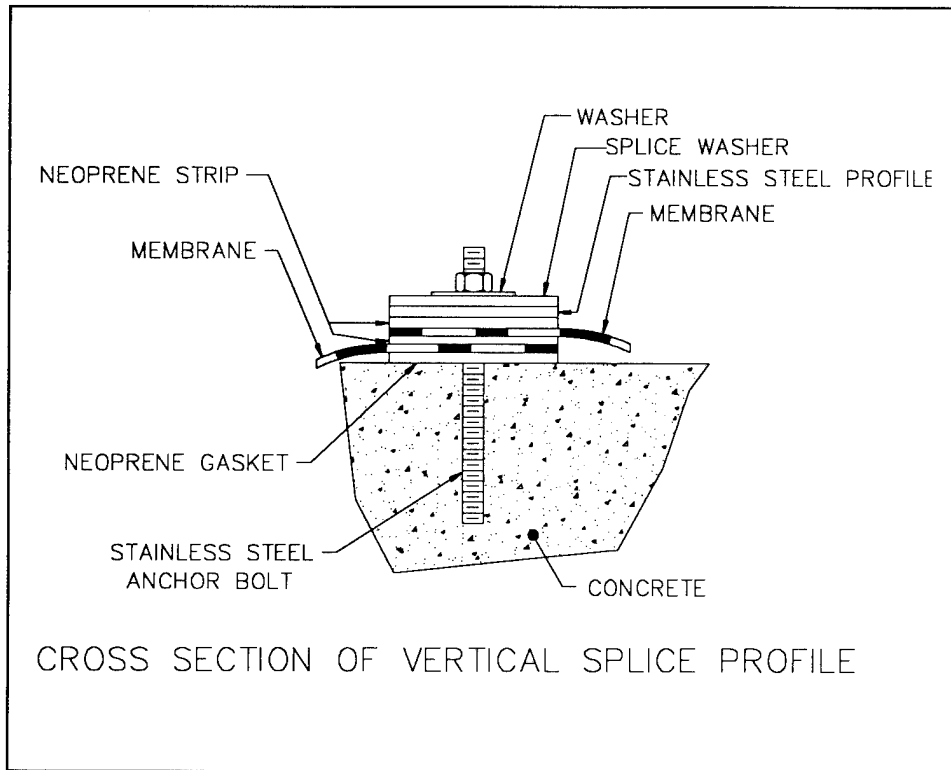

Figure 44. Vertical splice

Installation Procedure

General installation procedures were developed to support the conceptual design. These procedures are based on the research team's experience and are a preliminary approach to the issue. Procedures do not account for many of the details which must be addressed on a site-by-site basis such as the installation of a drainage collection and discharge system. Procedures are therefore likely to be refined, depending on results of further tests and applications. More detailed procedures should be developed on a project-specific basis while preparing the repair plans and specifications. General installation procedures are outlined in the following paragraphs.

Obtain and study available drawings of the structure. Gather additional information such as photographs and inspection reports from the project owners and operators.

Conduct site visit to make an initial assessment. Notes should be taken on the condition of concrete surfaces and the overall structure. The existence and efficiency of any existing drainage system must be ascertained. Confirm the location of all openings in the structure that could pose a suction hazard and establish an acceptable lockout/tagout procedure as required to ensure safety. Make a determination on the best method to conduct the detailed underwater inspection (remotely operated vehicle (ROV), divers, sonar, inspection trolley, or a combination). Determine the optimum location from which to conduct the inspection and installation work (barge, dam crest, abutment wall, etc).

Conduct a detailed above and underwater inspection of the area requiring rehabilitation to ascertain the extent and location of damaged areas. At a minimum, locate and document all leaking and badly damaged locations. Accurately define the limits of the proposed membrane installation using high-accuracy acoustics or precise physical measurements. Inspect and document overall concrete surface condition within the repair area and check for loose or delaminated concrete. Investigate the condition of the concrete to ascertain its ability to hold anchor bolts. Closely inspect and video document the proposed perimeter seal locations, again checking for loose or delaminated concrete (cleaning by brush or pressure washer may be required to adequately assess suitability for perimeter seal installation). Document the location and dimensions of any joints, cracks, or offsets that cross the perimeter seal locations.

Prepare a site-specific system design and installation procedure based on the data obtained during the detailed inspection and the project requirements. General design and procedures are presented in this report; site plans and specifications must account for details on a site-by-site basis. Plan the operation based on the developed plans and specifications, scheduling requirements and available resources.

After setting up the job site, begin installation by deploying the acoustic positioning array or other survey system as required. Position and anchor the bottom end of an alignment wire running vertically in close proximity and parallel to one side of the area to be covered by the membrane. The wire must be very accurately positioned since it establishes the baseline for the entire installation.

Pressure wash the concrete surface along the entire perimeter seal area of the first membrane section. Fill any cracks, joints, or surface irregularities as required in accordance with the site-specific system design. Deploy and position the geonet material if required by the site-specific system design. Secure the geonet to the concrete surface by driving impact anchors into predrilled holes. Position and install one anchor bolt adjacent to the alignment wire at the location established as the bottom corner of the first membrane section.

Lower the first roll of membrane to the diver with 20 to 25 ft of material already unrolled and the mandrel brakes set (lower the entire roll so the

membrane can be deployed from the bottom up). Align the bottom corner hole in the membrane with the previously installed anchor bolt by directing movement of the hoist rigging only and allowing the membrane to “hang free.” Install a nut and large washer to temporarily secure the corner of the membrane. Check the position of the edge of the membrane to ensure that it is parallel to the alignment wire. Check the roll to ensure that it will deploy flat against the concrete surface. Check the predeployed membrane for wrinkles or slack areas. Direct movement of the hoist rigging if necessary to carefully reposition the roll.

Beginning at the free corner of the membrane, commence installing the bottom horizontal sections of perimeter profiles and seals, ensuring that the membrane is pulled tight to remove all slack material before marking and drilling the anchor-bolt holes. Ensure that the butt joints at adjoining ends of the individual lengths of sealing gasket are tight against each other before commencing to tighten the anchors. Tighten each successive anchor bolt only enough to begin compressing the seal material. When all the bottom profile sections and anchors have been installed, inspect the membrane for slack material and wrinkles and tighten all anchor bolts to their specified torque.

Beginning at the bottom outboard corner, install the vertical perimeter profile and seal sections using the same procedure described for the horizontal profiles, ensuring that the edge of the membrane remains parallel to the alignment wire. As the profile installation progresses, deploy additional membrane from the roll in 20-ft increments by releasing the mandrel brake only enough to allow the roll to rotate while being hoisted but still maintaining slight tension on the deployed membrane. The mandrel brake must be reset during installation of the profiles and seals.

When the installation and tightening of the outboard vertical profiles has been completed, repeat the procedure on the upper horizontal perimeter seal. Tension is maintained on the membrane by topside personnel and softline rigging. With the three perimeter sides of the first section of membrane securely anchored and sealed against the concrete surface, begin work on the remaining vertical anchorage which will also form a membrane splice joint. Profile installation can begin from the top or bottom of the joint.

Drill holes and install all anchors in succession from one end of the joint. Place all joint materials over the anchors with the exception of the cap sections of profile to be installed later. Install a nut and large washer on every other anchor bolt to temporarily secure the materials.

Pressure wash the concrete surface along the entire perimeter seal area of the second membrane section. Repair and/or fill any cracks, joints, or surface irregularities as required in accordance with the site-specific system design. Deploy and position the geonet material if required by the site-specific system design. Secure the geonet to the concrete surface with impact anchors. Lower and position the material roll containing the second section of membrane in the same manner as the first section. Adjust the hoist rigging

until the holes in the 20- to 25-ft section of pre-deployed membrane are aligned with the anchor bolts in the splice joint profile.

Remove the temporary washers, place the second membrane over the anchor bolts, and install the cap profile sections of the joint seal beginning at the bottom bolt. Tighten the nuts only until the sealing gasket begins to compress. Continue until proper alignment of the membrane with the splice joint has been assured (estimate three full sections). Inspect the deployed membrane for slack material and wrinkles and proceed with installation of the bottom horizontal perimeter profiles and seals using the same procedure employed on the first membrane section.

When the bottom perimeter profile has been completed, continue with installation of the splice joint profiles employing the same procedure used on the vertical perimeter anchorage of the first membrane section. Install the top horizontal perimeter profiles using the same procedure as on the first membrane section. Installation of additional sections of membrane will be accomplished in a manner identical to that of the second membrane just completed.

Conduct a final inspection to ensure proper installation and document as-built conditions. Carefully inspect the entire perimeter and all splice joints for any indication of leakage. Inspect each anchor bolt for a visible indication of inadequate tightening. Document the final inspection.

5 Conclusions and Recommendations

The membrane system developed by SIBELON can be adapted for an underwater installation. Certain design details and procedures will have to be developed on a project specific basis.

The membrane system can be installed with or without the drainage system. The general system design and procedures support both configurations. Site-specific design details must also take into consideration the applicability of the various configurations. A drained system will be the system of choice required for most large repairs, while an undrained system can be suitable for small repairs.

While a repair system without drainage may reduce leakage as effectively as one with drainage, the system with drainage has advantages in that it is more durable and it better protects the structure. Since water is removed from the space between the membrane and the concrete, the system with drainage is less likely to become delaminated and damaged should the temperature drop below freezing or should the water level be drawn down below the top of the repair area than is the system without drainage. Furthermore, the system with drainage may reduce the potential for propagation of existing cracks by removing water from the cracks and other voids in the structure.

The size of the repair area and the amount of variance of the water level influence the decision to install a system with drainage or without and the decision of which type of vertical splice profiles to use. The basic system design can be adapted to a variety of exposure conditions. When deciding whether to install a system with or without drainage and discharge, the project owner must carefully weigh the requirements of the repair (i.e., to simply stop leakage or to protect the structure), the cost of the repair, and the applicability of the system. Table 9 describes the applicability of various configurations.

Table 9 Applicability of System Configurations		
System Configuration	Exposure Conditions	
	Always Totally Submerged	Sometimes Partially or Totally Unsubmerged
1) Full repair + drainage + pretension profiles	Green	Green
2) Drainage + simple profiles	Green	Yellow
3) No drainage + pretension profiles	Green	Red
4) No drainage + simple profiles	Green	Black
5) Small patch (no profiles)	Green	Red
Green = System is applicable Yellow = System is applicable, but will require special design details Red = System is applicable, but will require more extensive special design details Black = System may or may not be applicable; determination must be made on a site-by-site basis		

The research team recommends conducting a small-scale test to demonstrate the feasibility of the designed systems. Such a demonstration would consist of installation of the system on a small-scale structure which replicates situations likely to be encountered during an actual repair and testing of the system for watertight effectiveness. The installation should be performed underwater in a controlled environment. A conceptual design of the small-scale structure recommended for the demonstration is shown in Figure 45.

The simulated concrete structure will incorporate features replicating possible scenarios which could complicate the process of installing a membrane on a prototype structure. A portion of the structure will have an exposed aggregate surface to simulate deteriorated concrete. A portion of the structure will have concave and convex irregularities. Furthermore, the structure will have various convex and concave corners. A manifold will be built into the structure to allow a suction to be drawn behind the membrane. The manifold will have a discharge pipe with a means of monitoring any seepage through the perimeter or joint seals.

The structure will be submerged in a test tank to a depth of approximately 20 ft. Divers will install the designed system without drainage in accordance with the preliminary procedures described in Chapter 4. A suction will be drawn behind the membrane. The system will be evaluated by measuring the discharge to determine the extent of seepage bypassing the simulated repair. The entire process will be repeated using a system with drainage.

References

Cazzuffi, D. (1987). "The use of geomembranes in Italian dams," *Water Power and Dam Construction* 39(3), 17-21.

Ente Nazionale Italiano di Unificazione. (1988). "Edilizia, membrane per impermeabilizzazione (UNI 8202)," Genova.

International Commission on Large Dams. (1991). *Waterproofing geomembranes for dams - state of the art*, Bulletin No. 78, Paris.

_____. (1994). *Ageing of dams and appurtenant works*, Bulletin No. 93, Paris.

International Organization for Standardization. (1977). *Supports textiles revêtus de caoutchouc ou de plastique - Détermination de la résistance au déchirement (ISO 4674-A2)*.

McDonald, J.E. (1993). "Geomembranes for repair of concrete hydraulic structures," *The REMR Bulletin* 10(4), 1-6, U.S. Army Engineer Waterways Experiment Station, Vicksburg, MS.

Well, L.W. (1993). "Guidance for design of watertight geomembrane attachments to concrete surfaces." *Geosynthetics '93*, Vancouver.

Bibliography

- Akber, S. Z., Dascal, O., Rollin, A., and Lafleur, J. (1984). "Design of dam using geomembrane-geotextile sandwich, Robertson Lake Project, Lower Northshore-Quebec." *Proceedings of International Conference on Geomembranes*, Denver, CO.
- Bacchin, A., and Vallino, G. (1984). *Impiego di un manto impermeabile in polivinilcloruro semplice o armato come rivestimento di gallerie idrauliche in pressione*. Gallerie e grandi opere sotterranee.
- Baccini, S., Baia, P., and Giovagnoli, M. (1989). *Lineamenti progettuali della diga in calcestruzzo rullato di Concepcion in Honduras*. Associazione Idrotecnica Italiana, Comitato Nazionale Italiano delle Grandi Dighe, Technology of Rolled Concrete for Construction of Gravity Dams, Cagliari, Italy.
- Baccini, S., Carcamo, J., Ercoli, F., and Giovagnoli, M. (1991). *Roller compacted concrete dam of concepcion, Honduras*. Idrotecnica.
- Baldovin, G., Baldovin, E., and Fiamberti, A. (1994). "Rehabilitation and waterproofing of the upstream facing of Ceresole Reale Dam." *ICOLD 18th International Congress*. Durban, South Africa.
- Bister, D., Fayel, M., Garnier, G., and Guérinet, M. (1991). "French approach to thermo-mechanics in RCC dams experimental application to the Riou Dam." *International Symposium on RCC Dams*. Beijing, China.
- Bister, D., Bonnet, P., Charvoz, B., and De Beauchamp, T. (1994). *Maintenance des vieux barrages en béton à Electricité de France: techniques et coûts*. 4ème Colloque sur la réfection des infrastructures de béton en service, CRIB, Université de Sherbrooke, Québec.
- Bonanni, S., and Giovagnoli, M. (1992). *Diga di Concepcion in calcestruzzo rullato - Honduras*. Graziosi Quarry and Construction.

- Cancelli, A., and Cazzuffi, D. (1994). "Environmental aspects of geosynthetic application in landfills and dams." Keynote Lecture 2, *5th International Conference on Geotextiles, Geomembranes and Related Products*. Singapore.
- Cazzuffi, D., Monari, F., and Scuero, A.M. (1993). "Geomembrane waterproofing for rehabilitation of concrete and masonry dams - Lago Nero Dam, Italy." *International Society for Soil Mechanics and Foundation Engineering, Geosynthetics Case Histories*.
- De Beauchamp, T. (1994). *Concrete swelling and reinforcement measures at the Chambon Dam*. Hydropower and Dams.
- Degoutte, G., Antoine, F., Capra, R., et al. (1992). *Géomembranes et ouvrages hydrauliques*. Revue Générale des Routes et des Aerodromes.
- Dexter, Stephen C. (1985). *Handbook of oceanographic engineering materials*. Robert E. Krieger Publishing Company, Malabar, FL.
- Ercoli, F. and Giovagnoli, M. (1989). *Organizzazione di cantiere e metodi costruttivi per la realizzazione della diga in calcestruzzo rullato di Concepcion in Honduras*. Associazione Idrotecnica Italiana, Comitato Nazionale Italiano delle Grandi Dighe, Technology of Rolled Concrete for Construction of Gravity Dams, Cagliari, Italy.
- Ferratini, G., and Ripellino, P.G. (1989). *Barrage de Cignana: réparation du parement amont et mise en oeuvre d'une géomembrane d'étanchéité en PVC*. International Water Power and Dam Construction, Zurich.
- Garnier, G., and Guérinet, M. (1991). *Le Barrage du Riou (Hautes-Alpes): une approche des BCR rustiques*. Travaux (organe officiel de la Fédération Nationale des Travaux Publiques) n° 665.
- Giani, G.P., and Scuero, A.M. *Impermeabilizzazione del rivestimento di una galleria idraulica in pressione mediante messa in opera di un sistema di geomembrane drenate*.
- Giovagnoli, M., Ercoli, F., and Schrader, E. (1992). "Concepcion dam design and construction - problems and their solutions." *Proceedings of RCC III*. San Diego, CA.
- Giovagnoli, M., Schrader, E., and Ercoli, F. (1991). "Design and construction of concepcion dam." *International Symposium on RCC Dams*. Beijing, China.
- Giroud, J.P. (1989). *Are geosynthetics durable enough to be used in dams?*. Water Power and Dam Construction.

- Headquarters, Department of the Army. (1991). "Anchor embedment in hardened concrete," Engineer Technical Letter 1110-8-2(FR), Washington, DC.
- Koerner, R.M. (1986 and 1990). *Designing with geosynthetics*. Prentice Hall, Englewood Cliffs, NJ.
- Marulanda, A., Amaya, F., and Schrader, E. (1992). "Design of Miel II - A high RCC dam." *Proceedings of RCC III*. San Diego, CA.
- McDonald, J.E. (1990). "Anchor embedment in hardened concrete under submerged conditions," *The REMR Bulletin* 7(3), 4-7, U.S. Army Engineer Waterways Experiment Station, Vicksburg, MS.
- Monari, F. (1984). "Waterproof covering for the upstream of the Lago Nero Dam." *Proceedings of International Conference on Geomembranes*, Denver, CO.
- Monari, F., and Scuero, A.M. (1989). *Waterproofing of the upstream face of existing concrete dams with a PVC geomembrane*. International Water Power and Dam Construction. Zurich.
- Monari, F., and Scuero, A.M. (1991). "Ageing of concrete dams: the use of geocomposites for repair and future protection." *ICOLD 17th International Congress*. Vienna.
- Paolina, R., Terziani, A., Bianchini, A., Vielmo, I., Scuero, A.M., and D'Ancona, B. (1988). "Working group of the Italian National Committee on large dams." *Rinnovo dei paramenti di monte delle dighe in pietrame e malta e in calcestruzzo in Italia. Proceedings of BNCOLD Conference*. Manchester, UK.
- Ripellino, P.G. (1990). *Impermeabilizzazione del paramento di monte della diga di Cignana con geomembrana in PVC*. L'ingegnere.
- Rollin, A., and Rigo, J.M. (1991). *Geomembranes - Identification and Performance*. Chapman and Hall, Cambridge.
- Scuero, A.M. (1988). "RCC dams upstream face waterproofing." *Proceedings of ASCE Speciality Conference, Roller Compacted Concrete RCC 88*. San Diego, CA.
- Scuero, A.M. (1989). *La funzione di impermeabilità nelle dighe in RCC*. Associazione Idrotecnica Italiana, Comitato Nazionale Italiano delle Grandi Dighe, Technology of Rolled Concrete for Construction of Gravity Dams, Cagliari, Italy.

- Scuero, A.M. (1989). *Waterproof covering for the upstream face of existing concrete dams with a PVC geomembrane*. International Water Power and Dam Construction, Zurich.
- Scuero, A.M. (1989 and 1990). "Geosynthetic dans les barrages - Le barrage du Riou." *Geosynthetics in earth structures, Proceedings of the 3rd Italian Conference*, Bologna, Italy, and Agadir, Morocco.
- Scuero, A.M. (1990). "The use of geocomposites for the rehabilitation of concrete dams." *4th International Conference on Geotextiles and Geomembranes*. The Hague.
- Scuero, A.M. (1990). "Una barriera continua da cima a fondo nelle strutture idrauliche in terra." *Geosynthetics in Earth Structure, Proceedings of the 4th Italian Conference*, Bologna, Italy.
- Scuero, A.M. (1990). *Geocompositi per l'impermeabilità delle dighe in RCC: LA DIGA DI RIOU*. L'ingegnere.
- Scuero, A.M. (1993). "The use of geomembranes in the rehabilitation of free-flow canals and pressure tunnels." *International Water Power and Dam Construction*. Florence.
- Scuero, A.M., and Monari, F. (1989). "Waterproof covering for the upstream face of existing concrete dams with a PVC geomembrane - case histories: gravity dam (Piano Barbellino), multiple arches dam (Molato)." *Geosynthetics '89 Conference*. San Diego, CA.
- Scuero, A.M., Nuzzo, G., and Salvemini, A. (1990). "A continuous barrier from bottom to crown in hydraulic earthfill structures." *4th International Conference on Geotextiles and Geomembranes*. The Hague.
- Scuero, A.M., Sousa, Neves M., Silva, Matos D., Machado do Vale, J.L., and Camelo, A. (1994). "Waterproofing of the Pracana Dam." *5th International Conference on Geotextiles, Geomembranes and Related Products*. Singapore.
- Scuero, A.M., and Machado do Vale, J.L. (1994). "The use of geomembranes in the rehabilitation of free-flow canals and pressure tunnels." *2° Congresso da Agua*. Lisbon.
- Sembenelli, P. (1994). "Geosynthetics in embankment dams." *Geotechnical Engineering*. Oxford & IBH Publishing Co. PVT. LTD.
- Silva, Matos D., and Camelo, A. (1993). *La réparation du Barrage de Pracana*. Comptes rendus du Colloque Technique du Comité Français des Grands Barrages, Chambéry, France.

Silva, Matos D., and Liberal, A.O. (1993). "Pracana powerplant refurbishment and uprating: an uncommon and challenging project." International Water Power and Dam Construction, Florence.

Well, L.W. (1993). *Guidance for design of watertight geomembrane attachments to concrete surfaces*. CH2M Hill Inc., USA - Geosynthetics '93, Vancouver.

Zuccoli, G., Scalabrini, C., and Scuero, A.M. (1989). *The use of a geomembrane for an arch dam repair*. Water Power and Dam Construction.

Appendix A

Glossary of Terms and Abbreviations

geocomposite---a manufactured material using geotextiles, geogrids, geonets, and/or geomembranes in laminated or composite form; in this text, geocomposites referred to are geomembranes coupled with geotextiles.

geomembrane---a membrane with very low permeability used as a liquid or vapor barrier with foundation, soil, rock, earth, concrete, or any other geotechnical engineering-related material as an integral part of a human-made project, structure, or system.

geonet---a netlike polymeric material formed from intersecting ribs integrally joined at the junctions used for drainage with foundation, soil, rock, earth, concrete, or any other geotechnical-related material as an integral part of a human-made project, structure, or system.

geosynthetics---the generic term for materials used in geotechnical engineering applications; it includes geotextiles, geogrids, geonets, geomembranes, and geocomposites.

geotextile---any permeable textile used with foundation, soil, rock, earth, or any other geotechnical engineering-related material as an integral part of a human-made project, structure, or system.

membrane---general term to indicate a geomembrane or a geocomposite.

nonwoven---a planar and essentially random textile structure for geotextiles produced by bonding, interlocking of fibers, or both, accomplished by mechanical, chemical, thermal, or solvent means and combinations thereof.

neoprene---an elastomer, polychloroprene, formed by adding hydrogen chloride to monovinylacetylene.

profile---the batten strip used to provide linear anchorage of the membrane to the upstream face of the dam; profiles are often designed, based on site-specific conditions, to provide pretensioning during installation to remove wrinkles from the membrane and to provide a conduit for the water collection and drainage system.

transmissivity---the volumetric flow rate per unit thickness under laminar flow conditions within the plane direction of the geonet.

AAR Alkali-aggregate reaction

CSPE Chlorosulphonated polyethylene

CSPE-S Chlorosulphonated polyethylene with geotextile reinforcement

EPDM Ethylene propylene diene monomer

HDPE High-density polyethylene

IIB Isoprene-isobutylene butyl

NW Nonwoven

RCC Roller-compacted concrete

PP Polypropylene

PP-R Polypropylene with geotextile reinforcement

PVC Polyvinyl chloride

PVC-R Polyvinyl chloride with geotextile reinforcement

UV Ultra violet

VLDPE Very low-density polyethylene

Appendix B

SIBELON SYSTEMS Dams/CSE

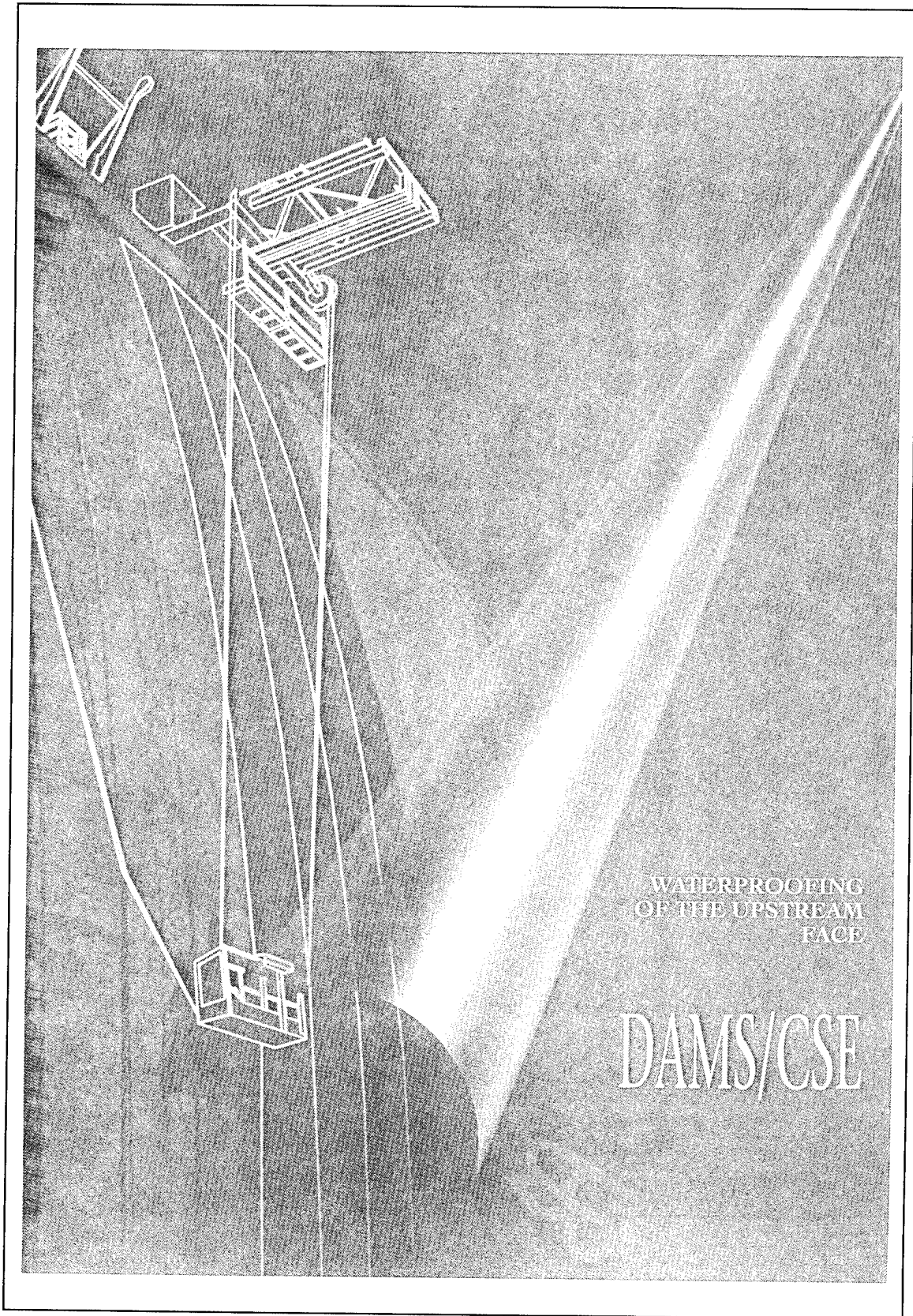

WATERPROOFING
OF THE UPSTREAM
FACE

DAMS/CSE

THE CONCEPT

SIBELON SYSTEMS DAMS/CSE is a patented system for waterproofing the upstream face of all types of dams and providing protection from the deterioration phenomena caused by seepage of reservoir water into the structure. Primary benefits include:

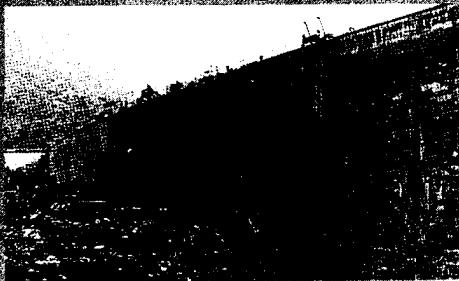

Cignana Dam before Intervention

- Stop further water seepage and deterioration
- Restore impermeability of the deteriorated dam face
- Dehydrate the dam body of previously infiltrated water
- Restore safety factor to original values

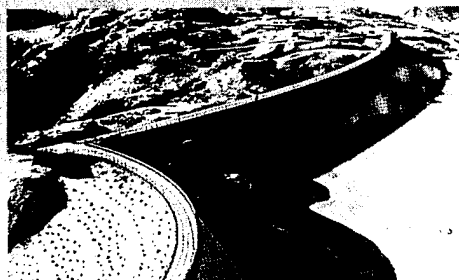

Cignana Dam after Intervention

The above benefits are achieved by installing a continuous impermeable barrier from the crest to the heel of the dam. The barrier is connected with the foundations and the grout curtain. A drainage system installed between the barrier and the dam face collects and discharges the water from seepage and dehydration.

The SIBELON SYSTEMS DAMS/CSE impermeable water barrier consists of a flexible polyvinyl chloride (PVC) geomembrane. Linear anchorage of the geomembrane to the upstream face of the dam is made by a couple of stainless steel vertical patented profiles. Perimeter watertight anchorage avoids by-passing of the barrier by the reservoir water.

Since the entire surface of the geomembrane is not attached to the dam face, the system allows drainage of the seepage water, and dehydration of the dam body from water which has already infiltrated it. A perimeter collection system at the heel of the dam allows discharge of the drained water.

The waterproofing system consists of the following primary components:

- a • Vertical anchorage and pre-tensioning profiles
- b • Drainage layer
- c • Waterproofing liner
- d • Perimeter anchorage and sealing profiles
- e • Drainage collection and discharge system
- f • Grouting

All components are manufactured in the controlled environment of a factory to ensure quality and uniformity. Operations on site are thereby limited to quick and easy assembly of prefabricated elements.

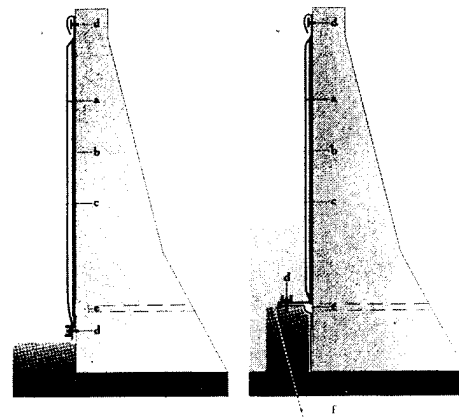

Waterproofing drained membrane

- b • The drainage layer (high transmissivity)
- c • The waterproofing liner
- g • Dam body (high permeability)

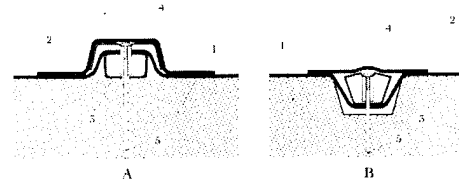
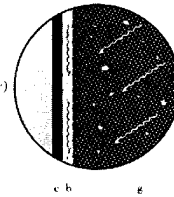

Horizontal Section through Steel Rib Fastening Systems

- A • Face-mounted rib (Lago Nero dam)
- B • Embedded rib (Cignana & Piano Barbellino dams)
- 1 • Concrete
- 2 • PVC geomembrane
- 3 • Two-part steel rib
- 4 • PVC cover strip over rib
- 5 • Rib anchor bolt

From "Watertight geomembranes for dams - State of the art" Bulletin N. 78 - CIGB - ICOLD - 1991

THE ELEMENTS

Vertical Anchorage and Pre-tensioning Profiles: the vertical profile assemblies provide linear anchorage of the waterproofing liner to the upstream face of the dam, and pre-tensioning during installation to eliminate wrinkles and slack areas. The vertical profiles also serve as free-flow conduits to the water collection and drainage system at the heel of the dam. All profiles and anchorage fittings are stainless steel.

Drainage Layer: it consists of a high transmissive synthetic material.

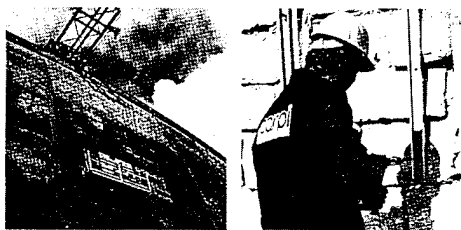

Waterproofing Liner: the waterproofing liner is a geocomposite, SIBELON CNT, consisting of a flexible, impermeable PVC based geomembrane which is coupled to a geotextile during the manufacturing process.

The PVC membrane is extruded in a homogeneous mass. The resin employed is PVC based and contains additives, plasticizers and UV stabilizers, which make it suitable for long term exposure to highly aggressive environments.

During the extrusion process the membrane is coupled to a non-woven geotextile, which provides for drainage and puncture resistance.

The waterproofing liner is manufactured in rolls, custom designed for each project to eliminate transversal splices and to allow easy installation and welding of adjoining sheets.

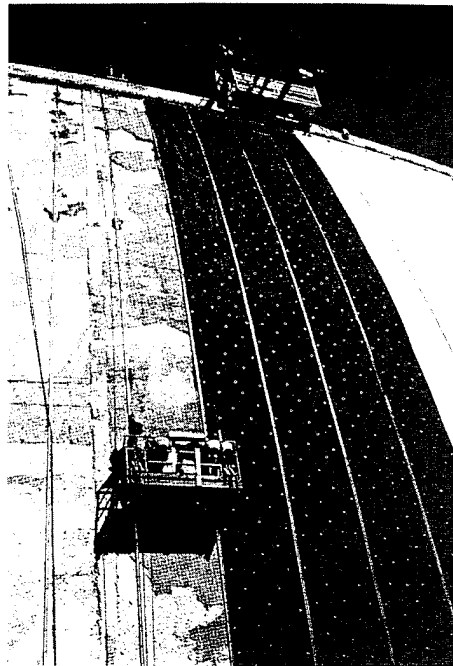
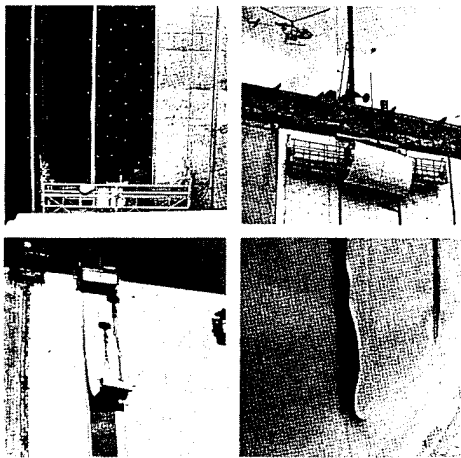

Perimeter Anchorage and Sealing Profiles: perimeter anchorage of the waterproofing liner must be watertight wherever there is a possibility of water by-passing from the reservoir, and therefore all along the lower perimeter of the dam, and in correspondance with spillways, outlet works, intake structures and protruding appurtenances from the upstream face.

The watertight seal is accomplished by compressing a suitable gasket with a steel profile. Perimeter profile design varies according to specific requirements of each project, such as type and conditions of the upstream face, and construction of a new foundation beam. All profiles and anchorage fittings are in stainless steel.

Drainage Collection and Discharge system: the SIBELON SYSTEMS solution, with an impermeable membrane and drainage layer attached to the upstream face, utilizes a water collection and discharge system to fully exploit the advantages offered by this solution. The collection and discharge system can be installed in a trench at the heel of the upstream face, in a new foundation beam, or as a specially designed drainage profile anchored on the upstream face.

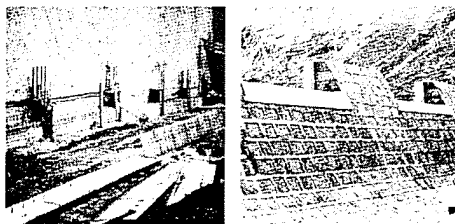

THE INTERVENTION

System Design: each SIBELON SYSTEMS DAMS/CSE intervention plan is specially designed for the specific project. Procedures and materials are selected relative to the type of dam, construction materials, degree of deterioration of the upstream face, the presence of extremely severe environmental conditions, the possibility of seismic events, and the desired end results.

Installation Procedure for a Standard Intervention.

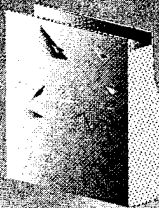

1 • The existing surface

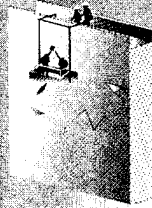

2 • Surface preparation

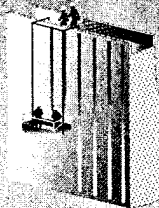

3 • Installation of vertical anchorage profiles

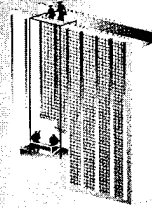

4 • Installation of the drainage layer

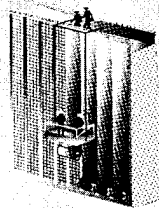

5 • Installation of the waterproofing liner

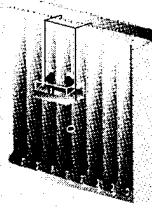

6 • Anchorage and tensioning of sheets

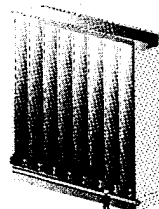

7 • Drainage collection and discharge system

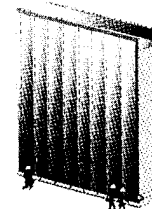

8 • Installation of the watertight perimeter anchorage

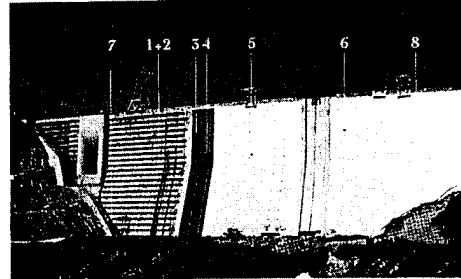

Pracana Dam - Installation general scheme

Surface Preparation

The intervention begins with preparation of the surface of the upstream face to ensure sufficient sound material exists to securely anchor and seal the profiles. Since the system can be installed on fairly rough surfaces, removal of all loose material and subsequent patching of the most severely damaged areas is usually sufficient. In the case of extremely rough surfaces, a thick geotextile can be installed against the dam face as additional anti-puncturing and transition layer.

Installation of Vertical Anchorage Profiles

The intervention continues with installation of the internal vertical profiles on the face of the dam. Profile locations are determined during the system design phase to eliminate conflicts with construction joints or other features of the dam. The profiles are fastened to the dam face by means of expansion and/or chemical anchors.

Installation of the Drainage Layer

When a higher drainage capacity is required, an additional layer of geosynthetic material (geonet, geotextile or other synthetic material with high transmissive properties) is installed against the upstream face of the dam. The material is anchored to the dam by impact anchors placed at predetermined locations.

Installation of the Waterproofing Liner

The liner is supplied in rolls. Each roll is first anchored at the crest, then deployed and aligned, then anchored and pre-tensioned from both edges using the external vertical profiles. Tensioning smooths the material and removes any wrinkles or sagging. The overlap of adjoining sheets is welded using the hot air method, followed by installation of the perimeter profiles. Finally, the external vertical anchorage profiles are covered with PVC strips hot air welded to the waterproofing liner.

Installation of the Perimeter Anchorage and Sealing Profiles

The installation of the watertight perimeter anchorage is one of the most critical features of the system. The greatest care is taken to ensure absolute watertight integrity especially at joints or fissured zones, where water could by-pass the system and infiltrate behind the liner.

Expansion and/or chemical anchors secure the perimeter profiles, which in turn compress the gasket material (for surface regularization and for distribution of the compressive stress) and waterproofing liner against the dam face.

Drainage Collection and Discharge system

The drainage collection system is installed above the watertight perimeter anchorage at the heel of the dam, between the waterproofing liner and the dam face. The system consists of a free-flowing collection pipe connected to transverse conduits which discharge into an inspection gallery or at the downstream face of the dam.

The system can be divided into sections to improve the accuracy of monitoring the source of discharged water. The system can be further improved with the addition of an electrical sensor system which facilitates very precise monitoring of the efficiency of the waterproofing liner.

P E R F O R M A N C E

Installation of SIBELON SYSTEMS waterproofing system on dams achieves the following:

- Waterproofing of the entire upstream dam face, including expansion and construction joints
- Protection from pure or sulphonated waters
- Protection of the dam body in case of alkali-aggregate reaction
- Protection from freeze/thaw cycles
- Reduction of uplifts
- Dehydration of the dam body
- An intervention which does not alter the structure of the dam
- A new surface drainage system

DURABILITY

All elements of the system have been designed to guarantee very long service life. The materials used in the manufacture of the geosynthetics, anchoring profiles and hardware, all have outstanding physical and chemical resistance characteristics, suitable to the environment they must face.

The performance and longevity of the overall system has been closely evaluated on a wide variety of installations dating as far back as 1970 and found to be excellent in all cases. The service life of the waterproofing liner and anchorage system installed on a dam is estimated to be several decades. Accelerated ageing tests in the laboratory showed SIBELON CNT to have a service life measured in hundreds of years. Those results were further confirmed by laboratory testing conducted on samples of liners which had been in actual service for years.

REFERENCES

To date, SIBELON SYSTEMS DAMS/CSE has been successfully installed on thirty dams in Italy, France, Portugal, Honduras. The system flexibility has allowed intervention on all types of dams at widely varied altitudes and latitudes. Ask for our updated list of references.

The ICOLD Bulletin N. 78 "Waterproofing geomembranes for dams", discusses a series of installations made by C.A.R.P.I. of the SIBELON SYSTEMS DAMS/CSE system as an example of functional rehabilitation of the upstream face of dams. Numerous other technical papers, magazine articles and presentations at various international specialty conferences also refer to the SIBELON SYSTEMS. Please feel free to ask for our updated list of literature.

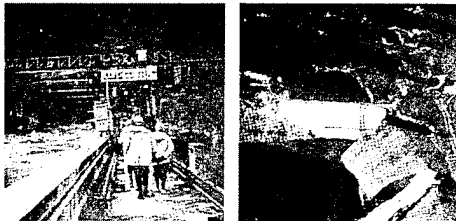

SIBELON is constantly striving to develop new and innovative intervention techniques. Currently in the experimental phase is a feasibility study for the underwater installation of SIBELON SYSTEMS DAMS/CSE, which would permit waterproofing intervention without the need to dewater.

SIBELON SYSTEMS DAMS/CSE

Thanks to its efficiency and durability, to its ease and speed of installation, to its adaptability to installation on heavily damaged surfaces and in severe environmental conditions which would be unthinkable with other methods, SIBELON SYSTEMS DAMS/CSE has become a well-known, highly respected and reliable method for the rehabilitation and protection of dams. Between 1970 and mid-1994, thirty dams have been waterproofed and protected with our proven impermeable geomembranes. Intervention projects have varied from simple installations on dams of medium height to a more challenging installation on a dam 174 meters high, from cold alpine climates with heavy ice formation to the equator, with extreme heat and long periods of exposure to direct sunlight. Owners, designers and contractors have appreciated SIBELON SYSTEMS DAMS/CSE as a dependable, cost effective solution to the need of a long term waterproofing protection.

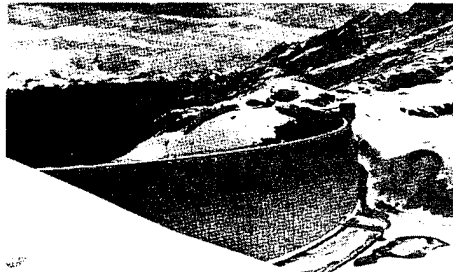

Peltre Dam - Italy



Concepcion Dam - Honduras

SIBELON SYSTEMS FOR CIVIL WORKS

Besides waterproofing and dehydration of the upstream face of dams, SIBELON SYSTEMS can offer a solution for waterproofing and protection of canals, hydraulic tunnels, reservoirs, highway tunnels, and for construction of landfills.

Ask for specific literature and references.

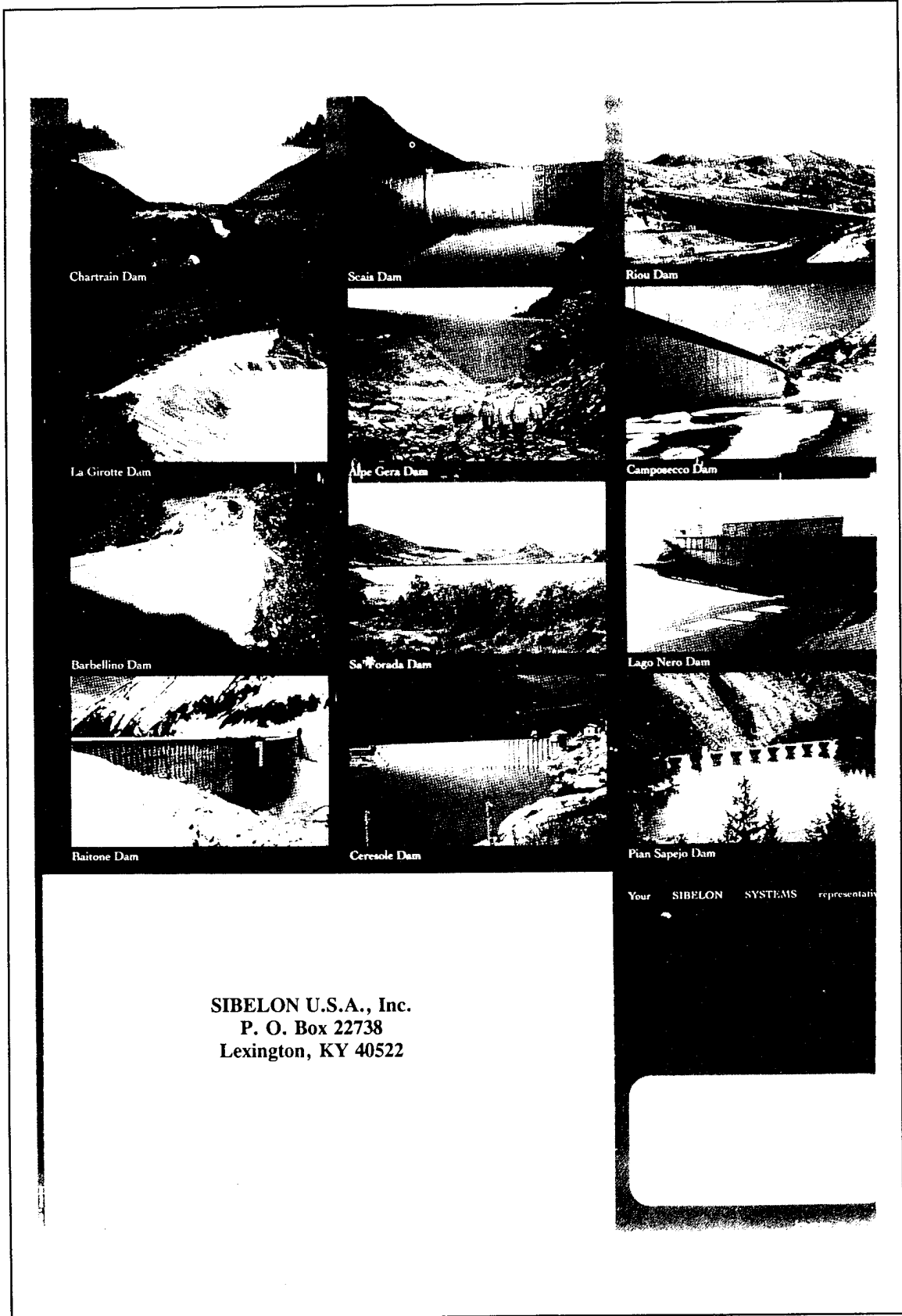

Chartrain Dam

Scais Dam

Riou Dam

La Girotte Dam

Alpe Gera Dam

Camposecco Dam

Barbellino Dam

Sa Forada Dam

Lago Nero Dam

Raitone Dam

Ceresole Dam

Pian Sapejo Dam

Your SIBELON SYSTEMS representative

SIBELON U.S.A., Inc.
 P. O. Box 22738
 Lexington, KY 40522

Appendix C GeoSyntec Report

Geomembrane Selection for Underwater Repair of Concrete Hydraulic Structures

TABLE OF CONTENTS

1. INTRODUCTION
 - 1.1 Terms of Reference
 - 1.2 Background
 - 1.3 Scope and Organization of the Report
2. DESCRIPTION OF GEOMEMBRANE APPLICATION
3. REQUIRED GEOMEMBRANE PROPERTIES
 - 3.1 Primary Function: Hydraulic Barrier
 - 3.2 Properties Required for Installation
 - 3.3 Properties Required for Long-Term Performance
4. GEOMEMBRANE SELECTION
 - 4.1 Selection Criteria
 - 4.2 Geomembrane Ranking

1. INTRODUCTION

1.1 Terms of Reference

This report was prepared by Drs. J.P. Giroud and K.L. Soderman, P.Eng. and reviewed by Dr. Kwasi Badu-Tweneboah, P.E., GeoSyntec Consultants, Boca Raton, FL.

1.2 Background

Considerable experience has been gained since the early 1970's in the rehabilitation of concrete dams using geomembranes. In all cases so far, the dam reservoir was emptied prior to the placement of the geomembrane on the upstream face of the dam. In virtually all cases, a polyvinyl chloride (PVC) geomembrane has been used for this application. A similar technique is presently being developed for underwater repair of dams and other hydraulic structures (e.g., locks and canals). The purpose of this report is to present an independent evaluation of the selection of the geomembrane for this new application.

1.3 Scope and Organization of the Report

This document presents an evaluation of the geomembrane materials available for use in waterproofing areas of existing concrete structures which are permanently under water. The evaluation is organized in three parts as follows. First, a description of the geomembrane application is presented including the anticipated installation and service conditions. Second, the required geomembrane properties are presented based on the geomembrane application. The last part of the document includes a comparison of the properties of available geomembrane materials to the required geomembrane properties for this application, and concludes with a ranking of the available geomembrane materials based on their suitability for this application.

2. DESCRIPTION OF GEOMEMBRANE APPLICATION

The geomembrane application being considered in this evaluation is the use of geomembranes to waterproof areas of existing concrete hydraulic structures which are permanently under water. The installation of the geomembrane and, if necessary, the repair of the installed geomembrane will be carried out under water using mechanical fasteners to tightly connect geomembrane panels together and attach the geomembrane to the surface of the concrete structure. Mechanical fasteners will also be used to secure patches if required.

It is our understanding that conventional seaming of geomembrane panels using thermal or solvent bonding methods is not anticipated to be used as the normal underwater procedure to install the geomembrane or repair the

installed geomembrane. However, these conventional seaming methods may be used at the factory to create prefabricated panels which are wider than the geomembrane roll produced by the geomembrane manufacturer. For example, if a PVC geomembrane is used, it is anticipated that a geomembrane panel having a width of approximately 6.5 m (21 ft) will be fabricated using three 2.1 m (7 ft) wide rolls. Wider panels can also be envisaged.

A geonet drainage layer may or may not be provided between the concrete surface and the geomembrane. The concrete upon which the geomembrane is to be installed may be badly deteriorated. As a result, the surface of the concrete may be relatively rough and abrasive and include localized depressions and, perhaps, even significant cracks.

It is expected, that during and following installation, the geomembrane will be submerged in either fresh or sea water at depths ranging from 0 to 100 m (0 to 330 ft). The range in expected installation and service temperature is from 0 to +20°C (32 to 68°F) and the required service life for the geomembrane is on the order of 20 years or more.

3. REQUIRED GEOMEMBRANE PROPERTIES

3.1 Primary Function: Hydraulic Barrier

The primary function of the geomembrane in this application is a hydraulic barrier to water (i.e., waterproofing). To perform this function it is essential that the geomembrane material has a low permeability to water. In addition, the number and size of defects (i.e., holes) in the geomembrane must be minimized. Defects in the geomembrane can occur during the manufacturing process, during handling and installation, and/or during the service life. Conventional manufacturing quality control and independent manufacturing quality assurance are usually sufficient to assure that prior to handling and installation there are generally no defects in geomembranes.

Providing independent construction quality assurance of the geomembrane installation is also an important aspect of minimizing the number and size of defects that occur in the geomembrane during handling and installation. In usual geomembrane applications, defects during installation occur mostly at field seams. In this application, however, it is anticipated that there will be no field seams, as mentioned earlier in this report. However, there may be leaks at the periphery of the area being waterproofed, where the geomembrane is mechanically fastened. It is anticipated that a stiff geomembrane may be less easy to fasten mechanically than a flexible geomembrane. Therefore, leakage at mechanical fastenings is more likely to occur with stiff geomembranes than with flexible geomembranes.

Defects during installation that are likely to impair geomembrane integrity may also occur as a result of improper handling, tearing and/or puncturing the geomembrane. As discussed subsequently in Section 3.3, because of the

rough and abrasive nature of the concrete surface, it is considered essential that a nonwoven geotextile cushion be provided between the geomembrane and the concrete surface to protect the geomembrane from damage. The geotextile cushion can either be independent of the geomembrane or be bonded to it to form a composite material. The composite material has a higher grab, tear and puncture resistance than the geomembrane alone. As a result, the number and size of defects in the geomembrane which occur during installation are expected to be reduced if a composite material (geomembrane bonded to nonwoven geotextile) is used. Such defects (i.e., those defects due to grab, tear, and puncture) sometimes remain unnoticed on very large projects. However, in the type of application discussed herein (i.e., an application involving only a small area), these defects are likely to be detected during installation. Therefore, they affect more the constructibility than the permeability of the geomembrane liner.

3.2 Properties Required for Installation

To facilitate its underwater installation, the geomembrane must sink. Therefore, either the geomembrane must have a specific gravity greater than one, or ballast weights must be attached to the geomembrane, which is very cumbersome. For the same reason, the geotextile, particularly if it is installed independently from the geomembrane, should be made with filaments that have a specific gravity greater than one. The requirement on geotextile specific gravity is less important if the geotextile is bonded to a heavy geomembrane because the geotextile will tend to follow the geomembrane. A geomembrane is heavy compared to a geotextile if it has a mass per unit area significantly greater than that of the geotextile (this is usually only the case if the geomembrane has a specific gravity greater than 1 and is thicker than 1 mm (40 mils)). It should be noted that a geomembrane bonded to a geotextile will sink less easily than a geomembrane alone because of the propensity of the geotextile to entrap air bubbles. This effect is likely to be more marked in the case of a light geomembrane than in the case of a heavy geomembrane.

Because of its extremely low flexural rigidity and its tendency to float because of entrapped air particles, the nonwoven geotextile, if it were installed independently from the geomembrane, would be very difficult to handle and install under water. To facilitate underwater installation of the geotextile, it is considered necessary that the geomembrane and the geotextile be provided as a composite material (i.e., heatbonded together). The stiffer geomembrane component of the composite material will provide flexural support for the nonwoven geotextile making it easier to handle and install under water.

Some hydraulic structures, such as arch dams, are not flat and the geomembrane must be able to deform to follow the overall shape of the concrete structure. In this respect, a stiff geomembrane is less desirable than a flexible geomembrane. Also, as discussed in Section 3.1, a stiff geomembrane will be less easy to fasten mechanically than a flexible geomembrane.

Finally, as discussed in Section 3.1, the use of a geomembrane-geotextile composite is beneficial to installation because it reduces the risk of damage to the geomembrane compared to a geomembrane alone, thereby reducing additional installation work which may be required if a geomembrane panel is mechanically damaged and must be replaced.

3.3 Properties Required for Long-Term Performance

In the long term, the geomembrane must withstand the pressure exerted by the water and must be durable. The face of concrete structures being repaired typically contains depressed areas with, sometimes, sharp edges and protruding elements such as aggregates. When water pressure is applied, the geomembrane elongates over the depressed areas and is subjected to concentrated stresses at locations where there are sharp edges and protruding elements.

A detailed study would be required to evaluate the elongation of a geomembrane over a typical depressed area. Simple calculations, considering depressed area geometries based on photographs of dam faces, suggest a conservative value of five percent for the geomembrane elongation. However, greater values are possible at specific locations. Regarding resistance to damage by concentrated stresses, the use of a geotextile cushion is considered necessary. As mentioned earlier in this report, the geotextile cushion can be independent of the geomembrane or bonded to it to form a composite material. It is known that the composite material has a higher puncture resistance and a higher burst resistance than the geomembrane resting on an independent geotextile cushion of the same type. The higher burst resistance improves the ability of the geomembrane to bridge cracks in the concrete.

In this underwater application, the geomembrane is exposed to somewhat ideal conditions from the standpoint of durability: permanent exposure to water at a relatively constant temperature. However, it should be noted that if the water were to contain chemicals, the compatibility between the geomembrane and these chemicals should be taken into account.

4. GEOMEMBRANE SELECTION

4.1 Selection Criteria

Based on the required geomembrane properties for this application discussed in Section 3, the following selection criteria have been developed:

- *Permeability.* This criterion reflects the desire for the selected geomembrane to have a low permeability so that it can perform its primary function as a hydraulic barrier. Because of the extremely low permeability of geomembranes it is very difficult to accurately determine geomembrane permeability to water in a laboratory test.

Water vapor transmission rates for geomembranes are easier to determine in a laboratory test and are considered an indicator of permeability. For this reason, water vapor transmission rates are used to evaluate the performance of geomembranes with respect to the permeability criterion. However, in the field the leakage of water through geomembranes is governed by defects more than permeability of the geomembrane material. In underwater installation the main potential for defects is at the mechanical fasteners, and defects are deemed more likely to occur with stiff geomembranes than with flexible geomembranes.

- *Constructibility.* This criterion considers how difficult it will be to handle and install the particular geomembrane in this underwater application. Geomembrane stiffness and specific gravity are key parameters in this criterion, since it is desirable for the geomembrane to be relatively flexible so that it can conform to the concrete surface, and have a high specific gravity (greater than one) so that it will sink in water making it easier to install. In addition, ease of installing the geotextile cushion is also considered in this criterion. In this regard, the geomembrane composites will fare better since the installation of the geotextile cushion will be much easier if it is bonded to the geomembrane than if it is independent.
- *Mechanical Performance.* This criterion considers the resistance the geomembrane has to damage during installation and service which would result in the occurrence of defects in the geomembrane and reduce its ability to perform its primary function as a hydraulic barrier. From the installation standpoint, key parameters for this criterion are geomembrane tensile strength, tear resistance and puncture resistance, with higher values being more desirable than lower values. Key parameters from the standpoint of service are geomembrane tensile strength and elongation, puncture resistance, burst strength and elongation, with higher values being more desirable than lower values.
- *Durability.* This criterion considers the resistance the geomembrane has to the exposure it will be subjected to during its service life. In this application the geomembrane will be continuously exposed to fresh or sea water at temperatures ranging from 0 to 20°C (32 to 68°F). Physical and chemical compatibility of the geomembrane with fresh or sea water in the above temperature range will play a key role in the evaluation of a geomembrane's durability for this application. It is assumed herein that the water does not contain chemicals (e.g., solvents or hydrocarbons).

In addition to the above four criteria, which are based on the required geomembrane properties, a fifth criterion has been developed:

- *Experience.* In the case of selection between two geomembranes that are otherwise equal, it is desirable to select the geomembrane with successful experience in a similar application. Hence, this criterion has been developed to benefit those geomembranes that have been successfully used in applications similar to the proposed application.

It should be noted that cost has not been included as a criterion herein because in this application the installation is very labor intensive and, as a result, the cost of the geomembrane represents only a small portion of the total cost of the project.

4.2 Geomembrane Ranking

The following geomembrane materials were considered in the ranking process:

- Polyethylene (PE)
- PE composite (wherein the geomembrane is bonded to a polyester nonwoven geotextile cushion);
- Polyvinyl Chloride (PVC);
- PVC composite;
- Polypropylene (PP);
- PP composite;
- Polypropylene and Ethylene - Propylene Diene Monomer Alloy (PP - EPDMA);
- PP - EPDMA composite;
- Ethylene Interpolymer Alloy (EIA);
- EIA composite;
- Reinforced Chlorosulfonated Polyethylene (CSPE-R) (commonly called Hypalon);
- CSPE-R composite;
- Reinforced Polyurethane (PU-R);
- Polyester Elastomer (PETE); and
- Ethylene-Propylene Diene Monomer (EPDM).

It is considered that the above list of geomembranes is representative of those geomembranes presently available in the United States. For several of the geomembranes a composite material has not been considered because, to the best of GeoSyntec's knowledge, such a composite material is not presently available.

As part of the ranking process, each geomembrane has been assigned a rating in each of the five selection criteria presented in Section 4.1. The possible ratings varied from 1 to 5 with the following definitions for each rating:

- Rating 1 means that there is a deficiency so serious that the considered geomembrane should be eliminated irrespective of its other ratings and its ranking.
- Rating 2 means fair.
- Rating 3 means average.
- Rating 4 means good.
- Rating 5 means excellent.

The total rating for a geomembrane is the sum of the ratings for each of the five selection criteria. The only exception to this is in the event that a rating of 1 has been assigned for any of the selection criteria. In this case, the total rating for the geomembrane is assigned a zero value.

The results of the rating for the considered geomembranes are presented in Table 1. Table 1 also indicates the ranking of the geomembranes. Geomembranes with the same total rating are assigned the same ranking.

As shown in Table 1, the PVC composite geomembrane is ranked the highest.

* * * * *

Table 1. Rating and Ranking of Geomembrane Materials

Geomembrane Material	Selection Criteria							Total Rating	Ranking
	Permeability	Constructibility	Mechanical Performance	Durability	Experience				
PVC Composite	5	5	5	4	5		24	1	
PVC	5	3	3	4	5		20	2	
CSPE-R Composite	5	4	4	4	3		20	2	
EIA Composite	5	4	4	4	3		20	2	
PE Composite	5	2	3	5	3		18	5	
CSPE-R	5	3	2	4	3		17	6	
EIA	5	3	2	4	3		17	6	
PP-EPDMA Composite	5	4	2	4	2		17	6	
PU-R	5	3	2	4	3		17	6	
EPDM	5	3	2	4	3		17	6	
PP Composite	5	2	4	4	2		17	6	
PET Elastomer	5	3	2	3	3		16	12	
PP-EPDMA	5	3	2	4	2		16	12	
PE	5	1	1	5	3		15	0	
PP	5	1	2	4	2		14	0	

NOTE: This table should only be read in conjunction with the accompanying text.

REPORT DOCUMENTATION PAGE

Form Approved
OMB No. 0704-0188

Public reporting burden for this collection of information is estimated to average 1 hour per response, including the time for reviewing instructions, searching existing data sources, gathering and maintaining the data needed, and completing and reviewing the collection of information. Send comments regarding this burden estimate or any other aspect of this collection of information, including suggestions for reducing this burden, to Washington Headquarters Services, Directorate for Information Operations and Reports, 1215 Jefferson Davis Highway, Suite 1204, Arlington, VA 22202-4302, and to the Office of Management and Budget, Paperwork Reduction Project (0704-0188), Washington, DC 20503.

1. AGENCY USE ONLY (Leave blank)	2. REPORT DATE September 1995	3. REPORT TYPE AND DATES COVERED Final report	
4. TITLE AND SUBTITLE A Conceptual Design for Underwater Installation of Geomembrane Systems on Concrete Hydraulic Structures		5. FUNDING NUMBERS Civil Works Research Unit 32636	
6. AUTHOR(S) J. Chris Christensen, Matthew A. Marcy, Alberto M. Scuero, Gabiella L. Vaschetti		8. PERFORMING ORGANIZATION REPORT NUMBER	
7. PERFORMING ORGANIZATION NAME(S) AND ADDRESS(ES) Oceaneering Technologies, Inc. 501 Prince George's Boulevard Upper Marlboro, MD 20772 SIBELON U.S.A., Inc. P.O. Box 22738, Lexington, KY 40522		10. SPONSORING/MONITORING AGENCY REPORT NUMBER Technical Report REMR-CS-50	
9. SPONSORING/MONITORING AGENCY NAME(S) AND ADDRESS(ES) U.S. Army Corps of Engineers Washington, DC 20314-1000 U.S. Army Engineer Waterways Experiment Station 3909 Halls Ferry Road, Vicksburg, MS 39180-6199		11. SUPPLEMENTARY NOTES Available from National Technical Information Service, 5285 Port Royal Road, Springfield, VA 22161.	
12a. DISTRIBUTION/AVAILABILITY STATEMENT Approved for public release; distribution is unlimited.		12b. DISTRIBUTION CODE	
13. ABSTRACT (Maximum 200 words) Geomembrane systems have been installed successfully on the upstream face of more than 20 concrete and masonry dams during the past 25 years. The success of these systems in controlling leakage and arresting concrete deterioration and the demonstrated durability of these materials are such that these systems are considered competitive with other repair alternatives. With a few exceptions, geomembrane installations to date have been accomplished in a dry environment by dewatering the structure on which the geomembrane is to be installed. Dewatering, however, can be extremely expensive and in many cases may not be possible because of project constraints. Development of conceptual designs for underwater installation of a geomembrane system to minimize or eliminate water intrusion and leakage through cracked or deteriorated concrete and defective joints in concrete hydraulic structures is described herein. <div style="text-align: right;">(Continued)</div>			
14. SUBJECT TERMS Concrete structures Hydraulic structures Underwater repair Dams Leakage Geomembranes Repair		15. NUMBER OF PAGES 102	
17. SECURITY CLASSIFICATION OF REPORT UNCLASSIFIED		16. PRICE CODE	
18. SECURITY CLASSIFICATION OF THIS PAGE UNCLASSIFIED	19. SECURITY CLASSIFICATION OF ABSTRACT UNCLASSIFIED	20. LIMITATION OF ABSTRACT	

13. ABSTRACT (Concluded).

The drained geomembrane system designed for underwater installation on the upstream face of a dam consists of a HDPE geonet drainage layer and a PVC geomembrane backed with geotextile reinforcement, anchored, and sealed around the perimeter and along vertical splices. Plans for underwater constructibility demonstration on a small-scale structure are also included.