

**NAVAL POSTGRADUATE SCHOOL
MONTEREY, CALIFORNIA**



19960223 076

THESIS

**MODELING OF SPECIAL FORCE
OPERATIONS FOR STRATEGIC OBJECTIVES
IN THE JOINT WARFARE ANALYSIS
EXPERIMENTAL PROTOTYPE (JWAEP)**

by

Chong Kwon Lim

September 1995

Thesis Advisor:

Samuel H. Parry

Co-Advisor:

Mark A. Youngren

Approved for public release; distribution is unlimited.

DTIC QUALITY INSPECTED 3

REPORT DOCUMENTATION PAGE

Form Approved OMB No. 0704-0188

Public reporting burden for this collection of information is estimated to average 1 hour per response, including the time for reviewing instruction, searching existing data sources, gathering and maintaining the data needed, and completing and reviewing the collection of information. Send comments regarding this burden estimate or any other aspect of this collection of information, including suggestions for reducing this burden, to Washington Headquarters Services, Directorate for Information Operations and Reports, 1215 Jefferson Davis Highway, Suite 1204, Arlington, VA 22202-4302, and to the Office of Management and Budget, Paperwork Reduction Project (0704-0188) Washington DC 20503.

1. AGENCY USE ONLY (Leave blank)	2. REPORT DATE September, 1995	3. REPORT TYPE AND DATES COVERED Master's Thesis	
4. TITLE AND SUBTITLE MODELING OF SPECIAL FORCE OPERATIONS FOR STRATEGIC OBJECTIVES IN THE JOINT WARFARE ANALYSIS EXPERIMENTAL PROTOTYPE (JWAEP)		5. FUNDING NUMBERS	
6. AUTHOR(S) Chong Kwon Lim		8. PERFORMING ORGANIZATION REPORT NUMBER	
7. PERFORMING ORGANIZATION NAME(S) AND ADDRESS(ES) Naval Postgraduate School Monterey CA 93943-5000		10. SPONSORING/MONITORING AGENCY REPORT NUMBER	
9. SPONSORING/MONITORING AGENCY NAME(S) AND ADDRESS(ES)		11. SUPPLEMENTARY NOTES The views expressed in this thesis are those of the author and do not reflect the official policy or position of the Department of Defense or the U.S. Government.	
12a. DISTRIBUTION/AVAILABILITY STATEMENT Approved for public release; distribution is unlimited.		12b. DISTRIBUTION CODE	
13. ABSTRACT (maximum 200 words) This thesis outlines the process of Special Force Operations for strategic objectives in theater-level warfare. The thesis designs and develops three models of these operations that can be implemented in Joint Warfare Analysis Experimental Prototype model. The first model is the Target model which selects the Special Operations Force (SOF) targets and optimal routes into the target theater. The second model is the Ingress model which represents the spatial shift of a Special Operations Force to the target area based on probability theory. The third model, which is divided into two parts, infiltration and combat, represents the process of attrition at the target. These three models are used in series to represent the complete SOF operation. An example and initial test of the models is a possible Korean scenario. Finally, recommendations for future improvements to the SOF models and JWAEP are presented.			
14. SUBJECT TERMS Special Operations Force, Joint Warfare Experimental Prototype, Target Model, Attrition model, Ingress Model		15. NUMBER OF PAGES 89	
17. SECURITY CLASSIFICATION OF REPORT Unclassified		16. PRICE CODE	
18. SECURITY CLASSIFICATION OF THIS PAGE Unclassified	19. SECURITY CLASSIFICATION OF ABSTRACT Unclassified	20. LIMITATION OF ABSTRACT UL	

NSN 7540-01-280-5500

Standard Form 298 (Rev. 2-89)
Prescribed by ANSI Std. Z39-18 298-102

Approved for public release; distribution is unlimited

**MODELING OF SPECIAL FORCE OPERATIONS FOR STRATEGIC
OBJECTIVES IN THE JOINT WARFARE ANALYSIS EXPERIMENTAL
PROTOTYPE (JWAEP)**

Chong Kwon Lim
Major, Republic of Korea Army
B.A, Korea Military Academy, 1985

Submitted in partial fulfillment
of the requirements for the degree of

MASTER OF SCIENCE IN OPERATIONS RESEARCH

from the

NAVAL POSTGRADUATE SCHOOL

September 1995

Author:

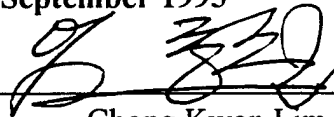

Chong Kwon Lim

Approved by:

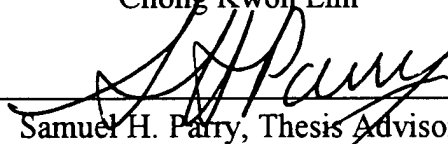

Samuel H. Parry, Thesis Advisor



Mark A. Youngren, Thesis Co-Advisor

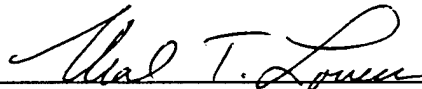

Neal Lovell, Second Reader

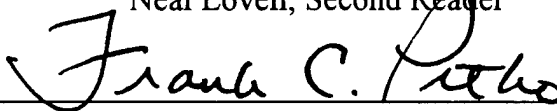

Frank Petho, Chairman

Department of Operations Research

ABSTRACT

This thesis outlines the process of Special Force Operations for strategic objectives in theater-level warfare. The thesis designs and develops three models of these operations that can be implemented in Joint Warfare Analysis Experimental Prototype model. The first model is the Target model which selects the Special Operations Force (SOF) targets and optimal routes into the target theater. The second model is the Ingress model which represents the spatial shift of a Special Operations Force to the target area based on probability theory. The third model, which is divided into two parts, infiltration and combat, represents the process of attrition at the target. These three models are used in series to represent the complete SOF operation. An example and initial test of the models is a possible Korean scenario. Finally, recommendations for future improvements to the SOF models and JWAEP are presented.

TABLE OF CONTENTS

I. INTRODUCTION	1
A. PURPOSE OF THESIS	1
B. BACKGROUND AND HISTORICAL PERSPECTIVE	1
C. PROBLEM STATEMENT	2
D. THESIS FORMAT	3
II. LITERATURE AND RELEVANT FACTORS	5
A. MOTIVATIONS	5
B. OVERVIEW OF SOF	9
C. REQUIREMENTS FOR MODERN ANALYTICAL APPROACH ..	11
D. STRUCTURE OF JOINT WARFARE ANALYSIS EXPERIMENT PROTOTYPE (JWAEP)	13
III. TARGETING MODEL	15
A. INTRODUCTION	15
B. TARGETING ANALYSIS	15
C. CONCEPT OF THE TARGETING MODEL	18
D. OPTIMAL ROUTING SELECTION	20
E. NETWORK RELATIONSHIP BETWEEN THE TARGETING MODEL AND JWAEP	21
IV. INGRESS MODEL	23
A. BACKGROUND	23
B. CONCEPTS OF THE INGRESS MODEL	23
C. PROBABILITY OF INGRESS	24

V. ATTRITION MODEL 29

 A. BACKGROUND 29

 B. CONCEPT OF THE ATTRITION MODEL 29

 C. INFILTRATION 31

 D. COMBAT ATTRITION 32

VI. MODEL APPLICATIONS AND ANALYSIS 35

 A. GENERAL 35

 B. RESULTS/ANALYSIS 35

VII. SUMMARY AND FUTURE RESEARCH 51

 A. SUMMARY 51

 B. FUTURE RESEARCH 51

 B. FUTURE RESEARCH 51

APPENDIX A. LIST OF NODES FOR SOF NETWORK 53

APPENDIX B. ARC ATTRIBUTES AND LIST 55

 A. ARC ATTRIBUTES 55

 B. LIST OF ARCS 56

APPENDIX C. NETWORK FOR SOF 61

APPENDIX D. TEST SCENARIO (FOR POSSIBLE KOREAN WAR) 63

 A. THE PURPOSE OF THE TEST SCENARIO 63

 B. GROUND ARC-NODE NETWORK 63

 C. TEST SCENARIO 64

LIST OF REFERENCES	69
INITIAL DISTRIBUTION LIST	71

LIST OF FIGURES

1. Operational Events in Korea Campaign	12
2. Joint Targeting Coordination Board (JTCB)	17
3. Decision Tree at each Node During Ingress	24
4. Decision Tree on Target	30
5. Posterior Comparison on Time to Target 1	43
6. Posterior Comparison on Time to Target 2	44
7. Posterior Comparison on Time of Target 3	44
8. Posterior Comparison on Time to Target 4	45
9. Posterior Comparison on Time to Target 5	45
10. Posterior Comparison on Time to Target 6	46
11. Posterior Comparison on Time to Target 7	46

LIST OF TABLES

1. Current Theater-level Models	8
2. Group of Possible Targets and Their Components	16
3. CARVER Value Rating Scale Matrix	19
4. Sample CARVER Matrix Application	20
5. The Representative Factors for Detection Rate	25
6. Detection Rate on Ingress Model	27
7. Two Aggregated Factors on Infiltration	31
8. Detection Rate for the Infiltration Process	32
9. Decision Logic and Main Issues on Modeling	36
10. CARVER Matrix for Objectives	38
11. Random Numbers Generated in Quattro-Pro	39
12. Target 1 Data	41
13. Target 2 Data	41
14. Target 3 Data	41
15. Target 4 Data	42
16. Target 5 Data	42
17. Target 6 Data	42
18. Target 7 Data	43

EXECUTIVE SUMMARY

The purpose of this research paper is to develop general methods to represent the use of Special Operations Forces (SOF) for strategic objectives, based on a stochastic wargame simulation, and to integrate the representation into the Joint Warfare Analysis Experimental Prototype (JWAEP) Model. This thesis applies some analytical models as an instrument to decide the cause and effect relationships 'before' and 'after' the Special Forces have been used. The relationships of interest include: how targets for SOF can be estimated; how much time is needed to infiltrate to the target; the probability of approach; the damage rate to the target; and the measures of effectiveness for those inputs.

The general approach requires the development of unique mathematical models for analysis in simulations.

The current JWAEP model does not represent the effect of Special Forces through any analytical model. However, in this new era of warfare, target-oriented means of attack such as nuclear weapons, chemical and bio-weapons, and special forces are increasing in importance. SOF can be very efficient in conducting surprise attack for operational and strategic objectives. Based on the Korean war scenario and JWAEP, this thesis addresses the following:

- What are the strategic and operational targets for SOF? What is the model for selection of targets for SOF?
- How can I model the events occurring during ingress of SOF to a target, with the associated probabilities of success?
- How can I model the probability that a SOF will succeed in its mission, given that it reached its target successfully?
- What are the effects on theater operations (as represented in JWAEP) of successful or unsuccessful missions?
- What is the optimal way to protect strategic targets against SOF?
- How can I detect enemy's SOF during ingress to their targets?

- What are the best locations for security units to protect SOF targets and to defeat the enemy as they approach?

The first model is the Target model which selects the Special Operations Force (SOF) targets and optimal routes into the target theater. The second model is the Ingress model which represents the spatial shift of a Special Operations Force to the target area based on probability theory. The third model, which is divided into two parts, infiltration and combat, represents the process of attrition at the target.

These three models are used in series to represent the complete SOF operation. An example and initial test of the models is a possible Korean scenario. Finally, recommendations for future improvements to the SOF models and JWAEP are presented.

I. INTRODUCTION

A. PURPOSE OF THESIS

The purpose of this research paper is to develop general methods to represent the use of Special Operations Forces (SOF) for strategic objectives, based on a stochastic wargame simulation, and to integrate the representation into the Joint Warfare Analysis Experimental Prototype (JWAEP) Model. This thesis applies some analytical models as an instrument to decide the cause and effect relationships 'before' and 'after' the Special Forces have been used. The relationships of interest include: how targets for SOF can be estimated; how much time is needed to infiltrate to the target; the probability of approach; the damage rate to the target; and the measures of effectiveness for those inputs.

The general approach requires the development of unique mathematical models for analysis in simulations.

B. BACKGROUND AND HISTORICAL PERSPECTIVE

As modern weapon systems develop very fast, they introduce the features of great lethality into war. For example, the invasion of Iraq and Kuwait illustrated the importance of the surprise attack by maneuver. Desert Storm showed a mix of air-land battle doctrine and high technology. Thus, modern warfare goes from attrition warfare to paralysis warfare, based on high technology and the surprise attack.

On the basis of these view-points, the Gulf War documented the emergence of a challenging new era for conventional warfare. The effect of high technology has revolutionized the nature of war.

Partly due to the reach and accuracy of modern deep-strike weapons, military thinkers have begun to argue that future battlefields will look very different from those of World War II. In the future, vast slow-moving military forces deployed along well-known front lines will be vulnerable to attacks by smart weapons launched from tens or even hundreds of miles away or dropped by attacking aircraft. As a result, modern armies are looking at concepts of non-linear warfare in which smaller, fast moving, more independent units maneuver around a

battlefield, coalesce to attack enemy formations, then melt away into a smaller component parts less vulnerable to smart weapons. As in war at sea, the focus will be not so much on seizing territory as on destroying enemy combat forces or paralyzing their function.

Thus, coalition forces in Desert Storm showed modern warfare by executing a deception before ground operations began, by the exploitation of space systems, the use of battle management system to coordinate the on-going battle, the use of aircraft for command and control, the use of special forces to disrupt an Iraq's rear area, the employment of airmobile troops to establish strong points well behind the front line, devastating armored thrusts conducted by all-arms maneuver groups, and by the achievement of air superiority and use of air strikes to neutralize enemy movements.

But there is another aspect to war. Although technology is a critical component in modern warfare, high technology weapons and military systems are useless in the abstract. A well-trained, professional military, capable of using technology and in service of an appropriate strategy, will continue to win wars. In other words, high technology weapons and systems can win wars only when deployed and operated in the proper context of military effort, trained people, and sound strategy. [Ref. 1]

In view of the two considerations, high technology and human factors, it is predicted that crucial, important objectives will be attacked by high-tech weapons, Tactical Air, SOF and their combination. Since high-tech weapons and air attack can be detected by the opponents' high-tech sensors, SOF is a very efficient weapon for a surprise attack.

C. PROBLEM STATEMENT

The current JWAEP model does not represent the effect of Special Forces through any analytical model. However, in this new era of warfare, target-oriented means of attack such as nuclear weapons, chemical and bio-weapons, and special forces are increasing in importance. SOF can be very efficient in conducting surprise attack for operational and strategic objectives. Based on the Korean war scenario and JWAEP:

- What are the strategic and operational targets for SOF? What is the model for selection of targets for SOF?

- How can I model the events occurring during ingress of SOF to a target, with the associated probabilities of success?
- How can I model the probability that a SOF will succeed in its mission, given that it reached its target successfully?
- What are the effects on theater operations (as represented in JWAEP) of successful or unsuccessful missions?
- What is the optimal way to protect strategic targets against SOF?
- How can I detect enemy's SOF during ingress to their targets?
- What are the best locations for security units to protect SOF targets and to defeat the enemy as they approach?

D. THESIS FORMAT

The purpose and historical background of this thesis are presented in Chapter I.

Chapter II discusses the motivation and overview of SOF, the structure of JWAEP and analysis factors of strategic and operational events.

Chapter III provides the SOF Target Model, and methodology for solving problems in target analysis. The problem is decomposed into target selection and optimal route selection. The CARVER model with six factors and Dijkstra's algorithm are used. Data are derived from the scenario of a possible Korean war based on a three phased Korean contingency.

Chapter IV treats the SOF Ingress Model. The basic concept of this model is an analytical process based on Binomial events.

The combat model is presented in Chapter V. It models the events on the target area between SOF and the target's security units. This is divided into two parts: infiltration and attrition. Lanchester's theory of attrition is used.

In Chapter VI, the three SOF models are applied to a Korean war scenario and analyzed. These results are the basic data for checking the effects of SOF in theater-level warfare.

Chapter VII provides the conclusion and recommendations for future research related to Korean situations.

II. LITERATURE AND RELEVANT FACTORS

A. MOTIVATIONS

1. Changes of World Order

When there were two superpower countries, the Soviet Union and the U.S.A., most third world countries were aligned with one power or the other. These alliances with one superpower or the other guaranteed the military security of a third world country from a threat posed by the other. However, after the disintegration of the Soviet Union, there is no axis of equilibrium in military power. The U.S.A. wants to preserve itself as the sole superpower country. Thus, countries with powerful economies, e.g., Japan, France, and Germany, have increased their initiatives on the international stage, and third world countries have declared their roles and interests. Thus, countries that had aligned themselves with the Soviets now have the tendency to employ their military power. This tendency increases the possibility of regional conflicts in Northeast Asia (containing North Korea).

2. Instability of Korean Peninsula

The Korean peninsula faces an increasing possibility of a second Korean war at the present time. The Korean peninsula is one of the most militarized areas in the world. Not only has North Korea fortified the Demilitarized Zone (DMZ) with extensive underground facilities, but also over 65 percent of its active ground forces are positioned between Pyongyang and the DMZ. Naval patrols and artillery provide heavy coastal protection. North Korea claims the coastal defense zone, and sometimes enforces this claim by capturing Japanese and South Korean fishing vessels. Military and military production facilities are well-protected, camouflaged, or underground. Aircraft, air-defense artillery, and surface-to-air missiles provide overlapping, in-depth air defense for forces and facilities. But, the most important point is that in addition to this preoccupation with defense, it is developing the capability to launch an independent surprise attack against South Korea. North Korea repeatedly proclaims its right and duty to 'liberate' South Korea. If Pyongyang perceives that the right conditions exist, it will use its forces to unify the peninsula. North Korea could

maximize its tactical advantage by launching a surprise attack supported by mobile forces. Drawing forces from four frontline corps supported by artillery and armored units, the initial attack will try to penetrate defense lines, cut off withdrawal routes and create an opening for mechanized and armored exploitation forces to press the attack. According to North Korea Army defectors, Pyongyang will try to neutralize the bulk of friendly troops positioned near the DMZ, derail the South's mobilization and American augmentation efforts, isolate Seoul, and begin negotiations, all within seven days. Any North Korean offensive will emphasize surprise, mobility, firepower, and possible chemical warfare. Especially before the main infantry attack, artillery groups would launch surface-to-surface missile and fire long-range guns along the front and Special Operations Forces would attack the strategic objectives of South Korea to frustrate their functions. In wartime, some of the nearly 60,000 military personnel assigned to the 22 Special Operations Forces brigades and seven Light Infantry Reconnaissance battalions would be available to open a second front in South Korea's rear area.

During offensive operations, corps reconnaissance units would conduct penetration missions to collect military intelligence and launch raids on military and civilian targets. Some units would infiltrate behind allied lines by land and sea, while others would cross into South Korea before the main attack through tunnels under the Demilitarized Zone. These units would penetrate at night to locate and destroy command posts, destroy lines of communication, create confusion in rear areas, interdict troop and supply convoys, attack military installations, and gain control of critical terrain. [Ref. 3]

3. Existing Models for High-Level Warfare

There are several theater models in existence today. The primary models in use are the Tactical Warfare model (TACWAR) [Ref. 4] and the Concepts Evaluation Model (CEM). Other theater-level models are JTLS, FORCEM, RSAS, and RESA. [Ref. 6] Table 1 depicts the development history and representation capabilities of these models.

a. JTLS (Joint Theater Level Simulation)

This model was first developed in 1983-84 for a group consisting of the Joint U. S. Readiness Command, the Army War College and the U. S. Army Concepts Analysis Agency. JTLS is a stochastic, real time player interactive simulation of Joint Theater combat. The basic ground maneuver unit in JTLS is a division or sometimes an independent brigade. Each division maintains a heterogeneous list of combatants by weapon system type. The air model basic entity is an air mission with a heterogeneous representation of the individual aircraft types involved and a detailed simulation of the progress of the mission against a specific target unit or location. Currently a means to depict the process of SOF combat is under development.

b. CEM (Concepts Evaluation Model)

This is a deterministic theater model of ground and air combat which has been upgraded through several versions since 1974 and is currently maintained by the U.S. Army Concepts Analysis Agency. This is an analytical model used primarily to analyze force effectiveness in theater-level warfare. It is designed to assess the effectiveness of different mixes of forces and resources and to estimate ammunition, equipment and personnel requirement.

c. RSAS (Rand Strategy Assessment System)

This model was developed in 1988 by RAND Corporation. RSAS provides a laboratory for the analysis of military strategy and operations in which alternative strategies and operations are evaluated in terms of the robustness of outcomes across the inherent range of uncertainty in scenarios, performance factors, and rules of war. It can also be used for training and other requirements.

d. TACWAR

This is a theater level combat model that examines the interaction of strategic and tactical forces in a conventional or chemical environment. It is intended to model the forces involved in a conflict at the brigade/regimental level or higher. The model allows an analytical group to examine alternative courses of action considered in the development of operational war plans and support an operational command group in the conduct of exercises

or prosecution of real world contingencies. TACWAR operates as a completely automated deterministic model and consists of a series of submodels covering air, ground and logistics operations, as well as operations in a chemical environment.

Model	Vintage	Proponent	Parts				Reference
			Ground	Air	Sea	SOF	
JTLS	1983's	CAA, USRC	o			Δ	Interactive Strategic includes Chemical
CEM	1970's	CAA	o	o			
RSAS	1988's	RAND	o				
TACWAR	1984's	Joint Staff (J-8)	o	o			
RESA	1982's	NOSC			o		

Legend: o = Represented in model
 Δ = Under development

Table 1. Current Theater-level Models

e. RESA (Research, Evaluation and Systems Analysis Facility)

This model is a research and evaluation tool for systems analysis and testing associated with naval command control and communications systems. It is also used for operation plan evaluation, command and control training support for senior officers, joint C³ interoperability assessment, warfare systems architecture analysis and wargaming support.

[Ref. 5]

4. Why SOF?

The activity of SOF is the same as that of common combat, but its results can affect theater-level operations. This is the reason SOF is referred to as a strategic or operational force.

At present, there are lots of theater-level models that treat the relationship between high-level units and campaign execution, but most of them treat the effects of conventional warfare without SOF activity.

Special Force Operations often are employable where high-profile conventional forces appear to be politically, militarily, or economically inappropriate. Small, self-reliant, readily deployable units that capitalize on speed, surprise, audacity, and deception may sometimes accomplish missions in ways that minimize the risks of escalation and concurrently maximize returns compared with orthodox applications of military power, which normally emphasize mass. Aircraft, artillery, or combat engineers, for example, might demolish a critical bridge at a particular time, but SOF could magnify the effects on the bridge while a train load of enemy dignitaries or ammunition was halfway across. Conventional land, sea, and air forces normally patrol specified sectors intermittently, whereas special reconnaissance troops may remain in hostile territory for weeks or months at a time collecting information that otherwise would be unobtainable. So, if an analytical model for SOF is designed and implemented in a current model, it will assist in the analysis of theater-level warfare. [Ref. 7]

B. OVERVIEW OF SOF

At the present, research for special operations connected with theater-level combat simulations cannot be found, so it is critical to study this area from the view-point of joint theater level warfare.

1. Definition of Special Force Operations

From the US dictionary for military terminology, special force operations is defined as:

Military operations conducted by specially trained, equipped, and organized DOD forces against strategic or tactical targets in pursuit of national military, political, economic, or psychological objectives. They may support conventional military operations, or they may be prosecuted independently when the use of conventional forces is either inappropriate or infeasible. Sensitive peacetime operations, except for training, are normally authorized by the National Command Authority (NCA) and conducted under the

direction of the NCA or designated commander. Special operations may include unconventional warfare, counter-terrorist operations, collective security and civil affairs measures.

2. Role of Special Operations Forces (SOF) in War

In a limited or general war, SOF can perform its missions at the strategic, operational, or tactical level to influence deep, close, or rear operations. However, the primary role of SOF is to conduct and support deep operations beyond the forward limits of conventional military forces. [Ref. 13]

SOF activities include the following:

- Strategic reconnaissance
- Unconventional warfare
- Direct action
- Counterterrorism
- Psychological operations

3. Structure and Ability of North Korea's SOF

North Korea's SOF are organized into 22 brigades and seven independent battalions. These forces have five missions: conducting reconnaissance, performing combat operations in concert with conventional operations, establishing a second front in the South Korea's rear area, countering South Korea's SOF in North Korea's rear areas, and maintaining internal security.

The Ministry of the People's Armed Forces has two primary commands that control special operations units - the Reconnaissance Bureau and the Light Infantry Training Guidance Bureau.

The North Korean Air force supports SOF with airborne infiltration and supply operations. The primary aircraft are 250 An-2/COLTs. The North Korean Navy support

amphibious operations and sea infiltrations. The principal vessel is the NAMPO personnel landing craft. Minisubmarines and semisubmersible insertion landing craft support agent missions.

North Korea SOFs have missions at the strategic, operational and tactical levels. The strategic mission ascertains the South's intentions, develops target information and attacks critical nodes, such as C³I facilities, storage facility air and air defense systems, in addition to kidnaping or interrogation of key personnel .

The operational mission is to support corps objectives, attacking weapon delivery systems, and attack major lines of communication.

The tactical mission is to support maneuver of division and brigade objectives. The size of SOF is usually from company to battalions. Its mission is to destroy command posts, air defense sites or force concentrations such as artillery positions, line of communication, or reserve troop areas. [Ref. 3]

C. REQUIREMENTS FOR A MODERN ANALYTICAL APPROACH

The analytical approach used should be appropriate for the time and situation. An analytical approach must reflect the significant differences between the theater-level and tactical level of warfare.

An example of this is found in military movement rates. An individual tank can run at 60 kilometers per hour (k/h) for an extended period of time. A tank company can move at about 25 k/h for most of a day. A tank division can move at most 5 or 7 k/h sustained over a day. This is an example of the discontinuity between levels of warfare. When we think about an analytical approach for theater level modeling, we need to consider four points. First, the aggregation of several factors is needed. Second, the analysis needs to focus on strategic and operational events, variations, and uncertainties. Simple linear scenarios that suggest a best estimate of the course of combat will almost always be wrong because they ignore the elements of surprise - a very important factor in modern doctrine. Third, the analysis needs to develop new procedures for presenting the uncertainties of combat to decision-makers and making these uncertainties more comprehensible. Special operations

forces and interdiction against logistics may be hard to model but may have important effects on battles and campaigns. Fourth, an analysis needs to adopt a new approach of developing simple but more comprehensive models; trade-offs between inputs and key assumptions can be adjusted to reflect the impact of the variations of the warfare [Ref. 9]. In view of these factors, the campaign in Korea, assuming a North Korean offensive, will be considered. Figure 1 shows a simplified series of operational events. These events can be divided into three parts [Appendix C].

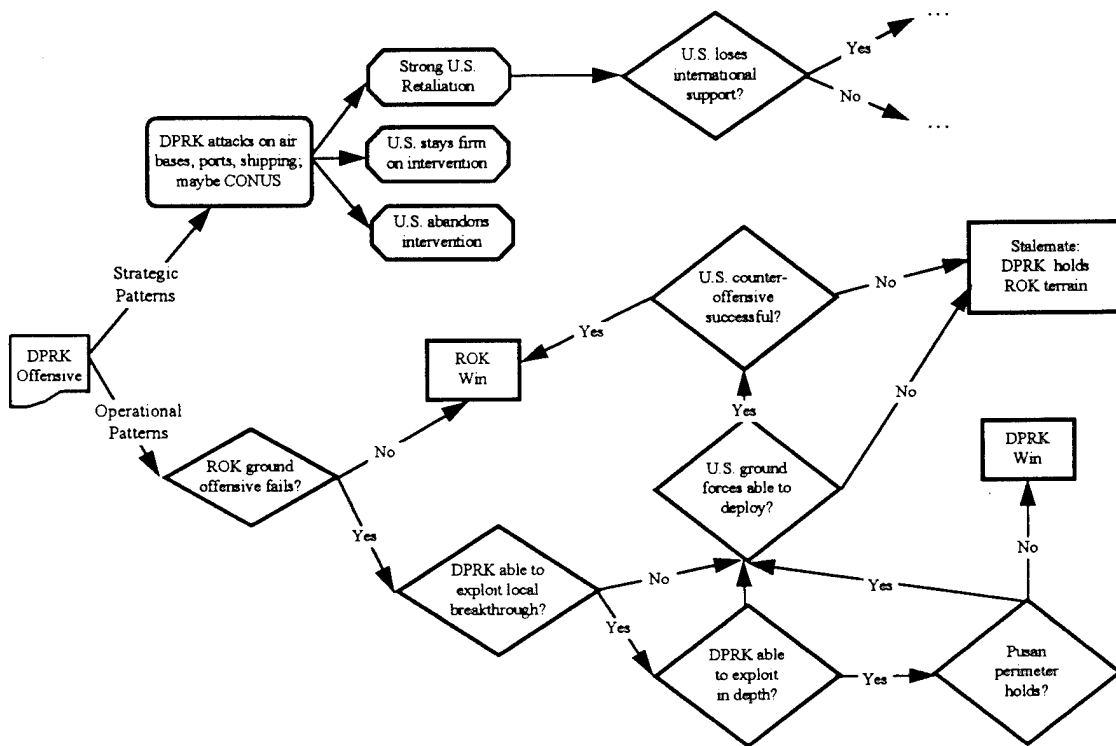

Figure 1. Operational Events in Korea Campaign

In this series of events, the most important event is the outcome of the first operational phase: whether the ROK forward ground defense fails or not. For this phase, North Korea will use artillery, tactical air and SOF. Among these methods, SOF is very efficient for destroying the functionality of strategic targets. Thus, the modeling of SOF is necessary, based on these requirements for an analytical approach.

D. STRUCTURE OF JOINT WARFARE ANALYSIS EXPERIMENT PROTOTYPE (JWAEP)

The JWAEP is a symbolic prototype model characterized by its aggregated, stochastic, information-intensive and dynamic nature. It is an interactive, two-sided, theater level combat model based on an arc-node representation of ground, air and littoral combat. The level of detail used in the model is appropriate for battalion to brigade-sized maneuver units, flight groups, and major combatant vessels. JWAEP is the software prototype developed by the Naval Postgraduate School for research and experimentation into stochastic and C³I centered approaches to modeling theater-level combat. A simulation solution method is suited for models in which relationships are expressed procedurally in the form of decision rules instead of algebraic formulas. A simulation of a symbolic model is obtained by sequentially acting out the processes and interactions of the model. [Ref. 10]

An analytic solution method uses an explicit mathematical formula for each output variable, which is itself a function of input variables. Analytical solution methods are desirable model designs because the input and output relationships are displayed in the explicit formula, which can be explained to gain a perspective about the model's performance and operations. Furthermore, sensitivity analysis that varies input parameters can be easily conducted on output variables. [Ref. 11]

1. Interactive Active Command & Control and Perception

The current JWAEP supports C³I through the presentation of a perception (derived from sensors) to a man-in-the-loop decision maker. The decisions can be stored in a data base to do non-interactive stochastic replications for analysis and "what - if" exploration. Decision rules are under development to permit complete non-interactive simulation. The key

to the model's C³I representation lies in the assignment of sensors to units, parts of the network, and footprints assigned to the terrain to develop separate stochastic perceptions of ground truth for Red and Blue players.

2. Ground Warfare

Ground warfare is executed upon a node-arc representation of key terrain, objectives, defensive points, and maneuver corridors. Units have full freedom to move anywhere on the network that they perceive at movement rates appropriate to the type and size of the unit and type of terrain. Thus, any type of maneuver warfare can be simulated on the network. Unit movement paths can be stated exactly or left to an automated path selection algorithm that chooses the "least cost path" where the cost function is also designated by the user.

3. Air Warfare

The air within a theater of operations is divided into a grid: each grid square represents the volume of air from ground up within the geographic area enclosed by a square. Air-to-air engagements are fought when aircraft encounter each other within a grid square; surface-to-air and air-to-surface engagements are fought between flights within an air grid and any ground targets or weapon systems on the terrain underlying the grid. Each grid square appears to the model as a node, with direct connectivity to eight adjacent squares (nodes); thus aircraft also choose a "least cost path" through a network to move to an engagement/target area and return.

4. Littoral Warfare

Littoral warfare is currently under development. A limited littoral warfare representation can be made by defining carriers as air bases on water nodes and Marine amphibious units as ground units that can move over water nodes and arcs that connect to the "dry land" ground network.

III. TARGETING MODEL

A. INTRODUCTION

Targeting is the process of selecting targets and matching the appropriate response to them, taking into account operational requirements and capabilities. Due to the combined nature of warfighting in some theaters, the targeting process varies from theater to theater. The method proposed in this thesis is generic, representing one way Special Operations Force (SOF) targeting can be executed. SOF targeting, like conventional targeting, combines intelligence and operations. It represents the integration of intelligence, threat information, the target system, and target characteristics with operational data on friendly force posture, capabilities, weapon effects, objectives, rules of engagement, and doctrine. Targeting matches objectives and guidance with inputs from intelligence and operations to identify the forces necessary to achieve the mission. Targeting support to SOF is unique because SO missions require detailed planning and are dependent upon precise intelligence.

B. TARGETING ANALYSIS

Targeting analysis is a unique subset of operational planning. Both activities focus on objectives but in different ways. In an abstract sense, the objective of operational planning is the aim or end of any actions; its substance is drawn from the mission statement of the supported commander. Target analysis concentrates on the focal points of the planned military action in an operation. Therefore, target analysis deals with objectives in the concrete sense (i.e., physical objects whose presence and location dominate the attention of the forces involved).

Target analysis is defined as the examination of potential targets to determine their military importance, priority of attack, scale of effort, and weapons required to obtain a desired level of damage or casualties. Analysis is performed to determine enemy vulnerabilities that can be exploited. It also determines what effects will likely be achieved against the target system and their activities. Table 2 shows the grouping of possible targets and their components.

Kind of Target	Sub-Target	Character	Suitable Attack Instruments			
			SOF	Missile	Artillery	Aircraft
Airbase	runways	large		Δ	Δ	○
	aircraft	movable	○			○
	shelter		○	○		○
	revetment			○	○	○
	maintenance facility	function important	○	○	○	○
	ammunition	explosive	○	○		○
	spares		○			○
	availability's		○			
	POL	explosive	○	○	○	○
C3 Facility	VAN	movable	○			Δ
	ANT	scattered	○			
Logistical Facility	Issue capacity	functional target	○			○
	supplies		○	○		○
Air-Defense	radar		○	Δ		
	TEL.		○			
Ground units	variable				○	○
Transshipment Points			○	○	○	○
Choke points		Time	○			
Supply Movement		Movable	○			
Strategic TGTs	variable		○	○	○	○

Legend: ○ = optimal Δ = acceptable

Table 2. Group of Possible Targets and Their Components

The functions and interactions between components and elements of the target system are essential to determine how the system works, focusing on what effects are likely to be achieved by attacking forces, where the system must be attacked, and how many forces should be sent.

In the United States, the focal point of target planning for conventional and SOF operations is the Joint Targeting Coordination Board (JTCB) of the theater CINC. Target analysis requires all-source intelligence with a high degree of topographic detail. This high-echelon, theater-level activity is appropriate to the task of orchestrating national, theater, and service intelligence production agencies and compelling all-source intelligence to support the targeting process. Figure 2 shows the target planning activities of the JTCB for US forces.

[Ref. 12]

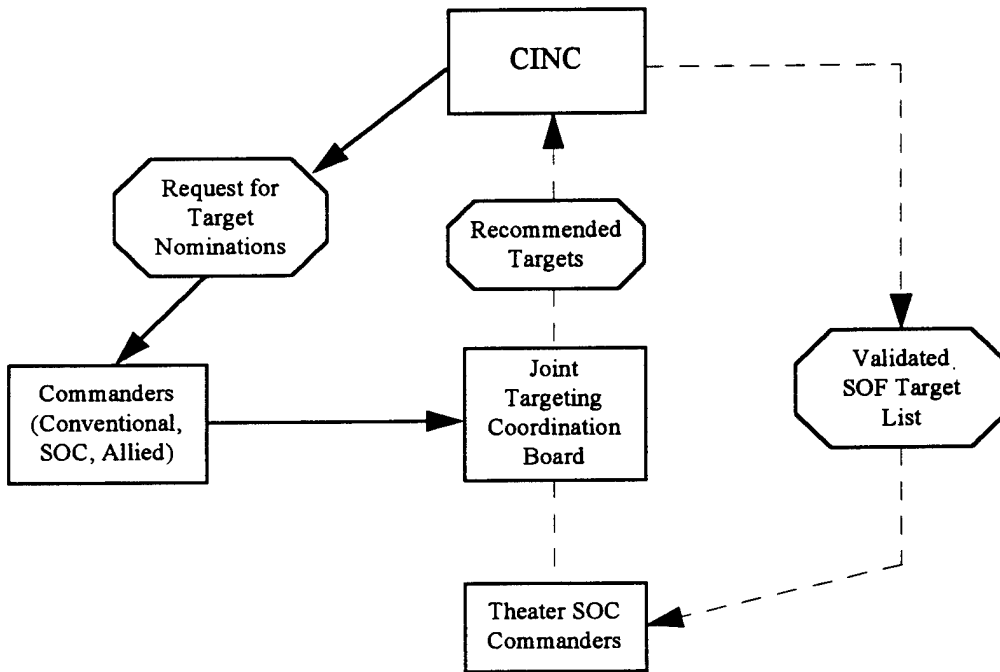

Figure 2. Joint Targeting Coordination Board (JTCB)

C. CONCEPT OF THE TARGETING MODEL

This model is divided into two parts: selecting targets and selecting optimal routes. Planners or commanders of special operations should sharpen their assessment of the suitability, feasibility, and acceptability of undertaking a special operation against a target by answering the following questions:

- Will destruction or neutralizations of the target contribute to the SOF mission or to the mission of the conventional commander?
- Is attack by SOF feasible?
- Is the target vulnerable to the level of destructive force that the SOF can apply?
- Is the expected damage to the target commensurate with the level of risk to SOF?
- Are other means of attack available?
- What is the possibility of compromise of conventional operational plans?
- What coordination will be required between SOF and the conventional force commander?

Therefore, the six factors to be considered are: criticality, accessibility, recuperability, vulnerability, effect, and recognizability (CARVER). In order to evaluate and assign a numerical value to the relative attractiveness of striking a target under consideration, a matrix is used in which the columns represent the individual headings of the acronym and the rows identify physical objectives such as individual targets or types of targets. A value of one to five is assigned for low to high attractiveness. [Ref. 12, pp. 54 - 59]

Table 3 shows the CARVER rating scale matrix. The definitions of the CARVER elements are:

C= Criticality: A target is critical when its destruction or damage will have a significant influence upon the enemy's ability to conduct or support its operations. Each target is considered in relation to other elements of the system or complex nominated or designated for attack. Criticality changes with the wartime situation.

A= Accessibility: A target is accessible when an action element can infiltrate the target area either by physical action or by direct or indirect fire weapons.

R= Recuperability: A target's recuperability is measured by time, i.e., how long it will take to replace, repair, or bypass the destruction or damage and return the system or complex to normal operational capacity.

V= Vulnerability: A target is vulnerable if the action element had the means and expertise to successfully attack and destroy the target.

E= Effect: An effective target will have significant political, economic, and sociological impact if attacked. Enemy reprisals against local citizens must be considered.

R= Recognizability: Can the target or target component be identified by the action element in all types of weather, day or night?

VALUE	C	A	R	V	E	R
5	Loss would be a mission stopper	Easily accessible. Away from security	Extremely difficult to replace. Long down time(>1yr)	SOF definitely has the means and expertise to attack	Favorable sociological impact. Impact on civilians OK	Easily recognized by all with no confusion.
4	Loss would reduce mission performance greatly	Easily accessible; outside	Difficult to replace with long down time(<1 yr)	SOF probably has the means and expertise	Favorable impact ; no adverse impact on civilians	Easily recognized by most, with little confusion
3	Loss would reduce mission performance	Accessible	Can be replaced in a relatively short time(months)	SOF may have the means and expertise to attack	Favorable impact; some adverse impact on civilians	Recognized with some training
2	Loss may reduce mission performance	Difficult to gain access	Easily replaced in a short time(weeks)	SOF probably has no impact. Adverse impacts on civilians	No impact. Adverse impact on civilians	Hard to recognize. Confusion probable
1	Loss would not affect mission performance	Very difficult to gain access	Easily replaced in a short time(days)	SOF does not have much capability to attack	Unfavorable impact. Assured adverse impact on civilians	Extremely difficult to recognize without extensive orientation

Table 3. CARVER Value Rating Scale Matrix

We can apply the CARVER matrix (Table 3) this to possible targets, as shown in Table 4.

TARGETS	C	A	R	V	E	R	TOTAL
POWER PYLONS	4	5	3	5	3	5	25
RUNWAYS	5	4	1	3	4	5	22
CABLE SYSTEM	5	4	4	4	5	4	26
UNDERGROUND CABLES	4	5	4	5	5	4	27
OBSERVATIONS TOWERS	3	3	3	5	4	5	23
COMMAND POST BLDG	5	3	3	4	5	4	24
SHIPS AT PIER	4	4	5	5	5	2	25
WAREHOUSES	2	5	3	5	5	4	24
ROAD & BRIDGE	3	4	2	5	3	5	22
MOBILE SAM SITE	3	1	3	3	5	2	17
FIXED SAM SITE	3	2	3	3	5	2	18
ANTENNA FARM	4	5	3	5	5	4	26
PERSONNEL	3	1	2	1	4	1	12

Table 4. Sample CARVER Matrix Application

In Table 4, we compare the total value of each target and choose the higher values, which become possible targets for SOF or other attack instruments. After this process, we determine the optimal route to these targets.

D. OPTIMAL ROUTING SELECTION

The basic concept of this process is the shortest path algorithm. The length of an arc (distance) is the basis of SOF's route to a target and can be counted as the value of the arc.

SOF will also use important features and topographical points as landmarks for keeping its direction; they may be included in a SOF path.

Thus, in a directed network $G = (N, A)$ with an arc length X_{ij} associated with each arc (i, j) that belongs to A , the network has a node S , which is the starting point for a SO force. The length of a directed path is defined as the sum of the lengths of arcs in the path.

The shortest path algorithm determines the shortest length directed path from node S to node i , at which a SOF target is located.

E. NETWORK RELATIONSHIP BETWEEN THE TARGETING MODEL AND JWAEP

The current ground network in JWAEP has physical nodes and arcs. The physical nodes are primarily located at intersections of avenues of approach and lines of communication. Other physical nodes are located at geographic points of interest, possible key terrain, airbases, logistical bases, probable and actual defensive battle positions, and terrain oriented objectives. [Ref. 15]

The arcs which connect the physical nodes are assigned the attributes of the corresponding terrain that lie between the nodal locations. One attribute is that of distance between nodes, measured along the contours of the terrain rather than the straight line distance. Other attributes are the road classification and width of the mobility corridor that the arc runs along, and the terrain classification along the arc.

In a SOF model network, the nodes and arcs should be specific to the SOF movement. At present, JWAEP's arcs are too long and the nodes are too large (they are resolved only to the level necessary to represent brigade/regimental movement). In a Korean contingency, possible strategic objectives and key terrain areas should be designated as nodes for SOF. In this SOF targeting model, the South Korean area is divided into three parts by the phase of the conventional warfare campaign. Phase I consists of 65 nodes for key terrain and objectives. The arcs in this model are the possible routes for SOF ingress. They closely follow an existing JWAEP arc but are more resolved. The arcs between nodes contain the attributes of distance, contours of the terrain, the level of forestation and the classification of

road and width of the mobility corridor. This special network for SOF movement is included in the example in Appendix C.

IV. INGRESS MODEL

A. BACKGROUND

In the real world, ingress represents the spatial shift of combat power, which includes the ground, air, sea and possibly combined operations, in accordance with decisions and plans. Traditionally, ingress is considered as the shift of modeled units from one set of coordinates to another. In this thesis, ingress considers the interactions between moving units and their environment (e.g., the effects of terrain, weather, security level, etc). In addition, this ingress model will contain various decisions that units make endogenous to the model, based on events or interactions that may take place during ingress. The movement is based on the SOF network, part of the arc-node representation in the JWAEP simulation system.

For SOF, ingress represents the spatial shift of combat power without the enemy's notice. This supports the intent of special force operations (surprise attack). Therefore, a decision will occur at every physical node, whether the SOF operation continues or not, based on whether detection has occurred or may occur. This makes it possible to model the "Go/No Go" decision and to estimate the possibility of successful shift of combat power using probability theory.

B. CONCEPTS OF THE INGRESS MODEL

Special Operations planners and executers are both concerned with the target priority, anticipated security level, terrain and weather during a mission. In the targeting model, the CARVER matrix can provide the target selection and network theory can solve for the optimal route to the target. In the ingress model, the possibility of a shift of combat power to the target is determined by using an exponential distribution for detection within a Monte Carlo simulation. [Ref. 17] When deciding upon the target, the SOF commander should consider the possibility of detection by the enemy, the condition of the terrain, the size of mission team, the weather, the type of mission area, possible reactions to SOF detection by inhabitants, and required time. However, the sheer number of combatants and weapons

system makes it impossible to maintain individual item resolution in the model. Models at the operational level have to sacrifice detail for scope by aggregating small units into larger units. This process of aggregation keeps the Ingress model within the limits of computer size and execution. The shift of combat power is simulated based on the assumption that events on ingress can be represented stochastically.

As shown in Figure 3, decisions will occur at every node. If the SOF team is detected, it returns to its base with 20% attrition of its combat power¹, using the same amount of time as needed during ingress to that point. If not detected, it will proceed with its mission to the next node.

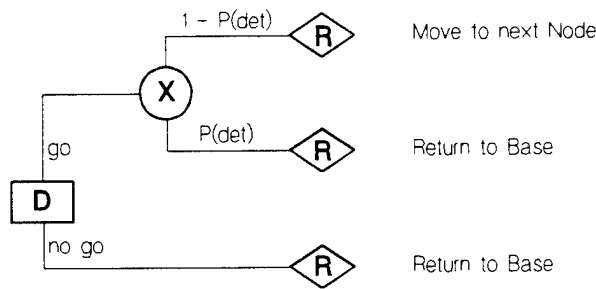

Figure 3. Decision Tree at each Node During Ingress [Ref. 18]

C. PROBABILITY OF INGRESS

As a unit moves between physical nodes, it is subject to detection by enemy sensors. The detection of a unit triggers a series of events that may identify unit size, its course of action (COA), etc. A possible detection can be thought of as originating from some type of

¹ It is assumed here that the SOF team can break up and successfully exfiltrate without contact after detection. The 20% attrition figure is arbitrary; a possible model extension may consider explicit modeling of attrition to a detected force.

sensor, such as a satellite overflights that dispatch other sensors (e.g., reconnaissance sorties, long range patrols, or cavalry scouts).

Detections are dependent upon several factors. These factors include the amount of cover and concealment available, the duration of time a unit is exposed to an opponent's sensor, and random chance. Therefore, it can be expressed as:

$$\text{Detection Rate} = f \{ g(\text{SO factors}), h(\text{enemy factors}), k(\text{environment factors}) \}$$

The relationship of the factors described above can be estimated from a high resolution simulation. For this model, each factor is considered at several levels as shown in Table 5.

SO size	Terrain Code	Security Level
A(small)	F(forest)	L(low)
B(middle)	M(mountain)	H(high)
C(large)	O(open)	

Table 5. The Representative Factors for Detection Rate

Example values for detection rates used to demonstrate the methodology are given in Table 6.

The variables used to determine detections within the ingress model are defined as:

T_{ij} : Transit time for a unit going from node i to node j.

D_{ij} : Time to detect at least one unit going from node i to node j.

U_{ij} : Number of units transiting from node i to node j.

λ_{ij} : Detection rate for a single unit transiting from node i to node j.

R : Random number drawn from an Exponential distribution with mean equal to one.

T_{ij} is modeled within JWAEP as a normally distributed random variable with the following parameters:

$$\text{Mean Time}(M_{ij}) = (\text{Arc Distance}) / (\text{Unit Movement speed})$$

Standard Deviation = 0.10 M_{ij} (a user input)

D_{ij} is computed as follows [Ref . 19]:

$$D_{ij} = (U_{ij} * \lambda_{ij})^{-1} * R \quad (1)$$

Note that D_{ij} is an exponential random variable because it is a multiplicative factor of an exponential random variable. In equation (1), the result comes from the detection rate, which is dependent upon the number of sensors (security size), the size of SOF, and the terrain. The detection process can be represented by the following sequence of events:

- A unit leaves node i for node j .
- T_{ij} is drawn from a Normal distribution as described above.
- D_{ij} , an Exponential random variable, is calculated.
- If D_{ij} is less than or equal to T_{ij} , then a detection occurs. If D_{ij} is greater than T_{ij} , then the transiting unit completes its movement undetected by the enemy.

Using this method, it is possible for a unit to evade detection even under conditions favorable to the enemy. Conversely, it is possible for a unit to attempt ingress during darkness, or through other forms of concealment, and still be detected by the searching force. This reflects the potential events faced by the commander in the field and is a realistic factor of combat. Using this method, the probability of detection at every node in an optimal route to the target can be determined.

Situation	detection Rate	Situation	Detection Rate
(A ,F, L)	.1054	(B, M, H)	.5108
(A, F, H)	.2877	(B, O, L)	.4308
(A, M, L)	.2231	(B, O, H)	.5978
(A, M, H)	.3567	(C, F, L)	.5108
(A, O, L)	.3567	(C, F, H)	.6931
(A, O, H)	.4308	(C, M, L)	.5978
(B, F, L)	.2877	(C ,M, H)	.7985
(B, F, H)	.4308	(C, O, L)	.6931
(B, M, L)	.3567	(C, O, H)	.9163

Table 6. Detection Rate on Ingress Model

V. ATTRITION MODEL

A. BACKGROUND

This model is composed of two parts: infiltration and combat based on a Lanchester attrition process. Aggregated attrition models describe the results of engagements among aggregated combat units. Since individual combatants are not represented in these units, details of one-on-one engagements are not simulated; instead the attrition process model considers average results.

Individual combatants are aggregated into combat units ranging in size from platoons to divisions. The contributions of the individuals are averaged together over weapon system classes within the unit. Discrete activities such as fire allocation, target acquisition, and lethality assessment are aggregated into a single process called attrition. Attrition is also averaged over periods of time from seconds to hours. The time unit in this model is one minute. [Ref. 6]

The attrition model in this section is a homogeneous model. In a homogeneous attrition model, combat attrition is assessed against a scalar measure of the unit's combat power. This scalar measure can be defined as "personnel"; in other cases it is a more abstract combat power measure. Most homogeneous attrition models determine the amount of attrition by computing attacker-to-defender force ratios.

B. CONCEPT OF THE ATTRITION MODEL

The attrition process in a large scale aggregated simulation is used to compute combat outcomes involving small parts of the total force. The attrition process is responsible for determining what fraction of weapon systems in the engaged units are within range of enemy targets, what fraction of the systems acquire enemy targets, and thus what fraction of the systems in a unit actually participate in the battle.

In this model, the outcomes depend on the characteristics of the target. Special forces are used to support the destruction of the enemy's function in warfare and contribute to the

conventional warfare strategy. As a result, the target of SOF depends on the main attack directions for conventional warfare and the commander's intent following the current phase of war. The security level in the target area also changes the outcome of combat. Security level is distributed from VL (very low) to VH (very high), affecting the engagement and termination criteria. Simulated battles continue until the SOF can withdraw or the level of security combat power in the target area reaches a specified threshold.

Figure 4 shows the event process in the target area. If the SOF arrives at the target without being detected, it can continue infiltrating to destroy the functionality of the strategic target. In this process, the mission of the SOF team is completely achieved if the SOF team is not detected (the target strength is reduced to zero), thus impacting on the outcome of the conventional war. If the SOF team is detected while infiltrating, the combat will proceed to some level, producing one of two results: SOF partial success or withdrawal.

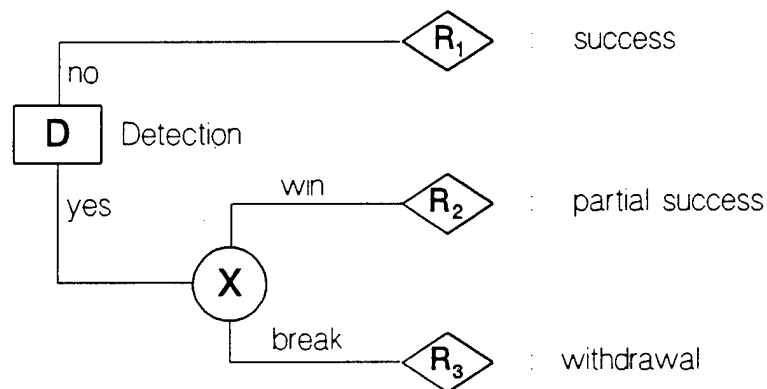

Figure 4. Decision Tree on Target

C. INFILTRATION

In the Ingress Model, the detection rate is related to aggregated factors. Different factors determine whether or not the SOF is detected and engaged in the target area. Therefore, we model:

$$\text{Pr (Detect on infiltration)} = 1 - \exp(-\lambda T) \quad [1]$$

where λ : detection rate

T : infiltration time

In this model, the time unit is different from that of the Ingress Model, and the detection rate is determined from another aggregated function as follows:

$$\lambda = G\{ f(\text{SOF size}), g(\text{Security size}), h(\text{Equipment level}) \dots \}$$

The detection conditions are aggregated into two factors shown in Table 7. Example detection rate values for these two major factors are given in Table 8.

SOF Size	Security Level
A(small)	VL (very low)
B(middle)	L (low)
C(large)	M (middle)
	H (high)
	VH (very high)

Table 7. Two Aggregated Factors on Infiltration

Situation	Detection Rate	Situation	Detection Rate
(A , VL)	.21	(B , M)	1.12
(A , L)	.33	(B , H)	1.47
(A , M)	.45	(B , VH)	1.83
(A , H)	.57	(C , VL)	1.02
(A , VH)	.71	(C , L)	1.38
(B , VL)	.58	(C , M)	1.85
(B , L)	.86	(C , H)	2.40
		(C , VH)	3.22

Table 8. Detection Rates for the Infiltration Process

D. COMBAT ATTRITION

The development of the attrition model used in this model is based on the work done by Lanchester. Lanchester - type attrition models refer to the set of differential equations that describes the change over time in the force levels of combatants and other significant variables that describe the combat process. [Ref. 20, p. 28] The results of combat depend on what fraction of the target is within range of the SOF's attack, how well organized the C² (command & control) of the target is, and what fraction of security units actually participate in the combat. Simulated combat continues until the SOF's withdrawal or achievement of partial success, based on the SOF's attrition threshold and remaining effectiveness due to casualties and logistics.

The Lanchester model expresses casualties in terms of force size. Lanchester differential equation models have gained importance through their ability to provide insight into the dynamics of combat and their applicability to the entire hierarchy of combat operations. Further, these differential equation models provide a basis for developing quantitative insights into combat dynamics. [Ref. 2]

The concepts are based on the following:

- Force size is a function of time, and the continuous real time variables $x(t)$ and $y(t)$ are approximations to the discrete combat units in a real force. So

$$\frac{dX}{dt} = f(x,y) \qquad \frac{dY}{dt} = g(x,y)$$

$X(t)$ = size of SOF the time t

$Y(t)$ = size of defense unit at time t

- Attrition of a force is a function of force size and the other possible parameters, thus,

$$\text{casualty rate} = f(\text{force size, other possible parameters})$$

Considering the nature of modern weapons and how the concentration of fires could be achieved, two cases are estimated: aimed fire and area fire. In this model, the SOF is assumed to know the location of target elements; thus, it uses aimed fire. But even if the security unit detects the SOF, every element of the securing force does not know the exact position of all SOF personnel; therefore, area fire is applied. The result is a mixed law for combat. [Ref. 20, pp. 167-170]

$$\frac{dX}{dt} = -\alpha XY \qquad \frac{dY}{dt} = -\beta X \qquad [2]$$

where X_0 = initial size of X (SOF) force
 Y_0 = initial size of Y (security) force

(α, β) depend on the characteristics of weapons and personnel for the SOF and the security unit.

To determine the possible damage to the target if a SOF force is detected before completing its mission, the objectives for each force are considered. The security force, defending its base, may be expected to fight until annihilated (or they reach a breakpoint). The SOF force,

on the other hand, will seek to withdraw if the level of personnel and equipment remaining falls below the level at which it can accomplish its mission. The following assumptions are made:

- The amount of target damaged is inversely proportional to the SOF size remaining, if it wins the engagement. For example, if the SOF has 70% of the force survive an engagement with the security force, 30% of the intended damage to the target is accomplished.
- The engagement between the security force and the SOF will continue until the security force or the SOF reaches their respective breakpoints.
- If the SOF force breaks first, no damage to the target is achieved.

From this process, the following Measure of Effectiveness (MOE) can be compared to breakpoint thresholds. [Ref: 2]

$$\text{Security force remaining} = \frac{\text{Combat power after the engagement}}{\text{Combat power before the engagement}} \geq a$$

$$\text{SO force remaining} = \frac{\text{Combat power after the engagement}}{\text{Combat power before the engagement}} \geq b \quad [3]$$

$$\begin{aligned} \text{Target damage}^1 &= 1 - \text{SO force remaining} && \text{if SOF greater than } a \\ &= 0 && \text{otherwise} \end{aligned}$$

where **a**: the threshold for the security unit (may be zero)

b: the threshold for the Special Operations Force

VI. MODEL APPLICATIONS AND ANALYSIS

A. GENERAL

The methodology is applied using three models. First, the target-selection process generates the optimal target from among the possible targets and the best route to each target. The second model considers the possibility of ingress. On the way to the target, the conditions along each arc are assumed independent, so the probability of detection is counted independently at each node, using the factors shown in Table 6. From this detection rate, the time required to be detected is computed. The difference between transit time and the detection time realized is used to make the "Go/No Go" decision.

Finally, the Attrition Model consists of the infiltration and combat processes. Upon arriving at a target, the SOF team infiltrates and executes its mission but the probability of detection is changed. The detection rate at the target is generally higher than the rate on ingress. In the combat process, the remaining functionality is estimated by the ratio of attrited strength to original strength. The results show the effect of SOF in Joint warfare. The decision logic and issues related to the three models are given in Table 9.

B. RESULTS/ANALYSIS

The three models described in the previous chapter were tested using a notional Korean war scenario. The results were obtained from the test scenario in Appendix C. The scenario provided a feasible theater-level conflict situation for the initial test of the models. The territory of Korea was selected as the basis of the test scenario although it was scaled down and edited to provide to a workable and unclassified test scenario.

MODEL	DECISION LOGIC	ISSUES & PROCESS
Target Model	 <pre> graph TD A{What is the SOF target?} --> B{Which target is best for this phase?} B --> C{What size of SOF for this target?} </pre>	<ul style="list-style-type: none"> • Kinds of possible target for strategic objective. • The number of components in these targets • Amount of weighted importance to each target. • CARVER matrix • Ability of SOF • Equipment of SOF for this target
Ingress Model	 <pre> graph TD D{How can SOF approach the target?} </pre>	<ul style="list-style-type: none"> • Ways to approach • SOF's velocity of advance • How to check SOF's advance (security units) • Factors to block the SOF (terrain, weather)
Attrition Model	 <pre> graph TD E{How can SOF's activity be assessed?} --> F{How does SOF attack the target component?} </pre>	<ul style="list-style-type: none"> • Engagement on Infiltration • The Ratio of Combat power • Distribution of SOF power • Damage to forces involved • Total damage estimate
JWAEP	 <pre> graph TD G[Effect in JWAEP] </pre>	<ul style="list-style-type: none"> • Analysis of SOF activities • Efficiency of theater-level SOF units

Table 9. Decision Logic and Main Issues on Modeling

1. Ground Network

Sixty-five nodes and 122 arcs were established for the middle part of the Korean peninsula. The nodes represent the important features, i.e., main cities on avenues of approach and significant terrain. Some nodes contain an air base, logistical facility, key terrain, security, and defense units around the Demilitarized Zone (DMZ). Arcs are based on roads that can be used as check-points for SOF routes. The arcs which connect the nodes are assigned the characteristics of the terrain. The arcs are the basis for distance between nodes, terrain, detection rate, and the time needed to move. The list of arcs and nodes associated with the 65 node Korean peninsula network is at Appendixes A and B.

2. Application for Target Model

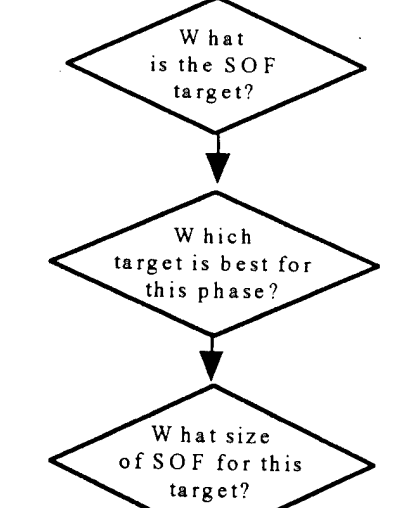
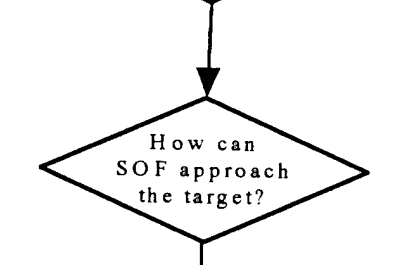
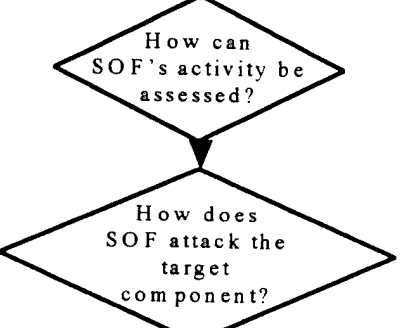
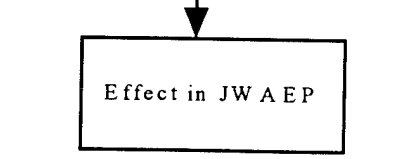
Based on the scenario, SOF goals and objectives in the initial battle were to:

- Destroy all significant power and communication facilities throughout the theater.
- Reduce the effectiveness of tactical airfields at Sown/Osan.
- Disrupt the C² (command & control) of the Field Army Command Post.
- Paralyze the function of command in possible tactical nuclear weapon -containing area of US installation in Korea.
- Disrupt off-loading operation at shipyards, airports in Kimpo.

These goals and possible targets for SOF take the Korean situation into consideration.

The results of the CARVER matrix used for this example are in Table 10. In this matrix, the target groups and their locations are given.

Kind of Target	TGT	Location (node)	C	A	R	V	E	R	Total	Selection	SOF size
Air Base	• OSAN (K55)	n53	5	5	5	4	3	5	27	✓	5
	• Pyongtaek CPX	n60	3	4	3	4	3	5	22		
	• KwangJu	n39	1	2	2	3	4	3	15		
	• Sowon	n48	4	5	4	4	5	4	26		
	• WonJu Air Sta.	n46	2	3	3	2	2	3	15		
Strategic TGTs	• Gwa Chen govnmnt bldg	n36	5	5	4	3	5	4	26	✓	8
	• Paldang Dam	n34	5	4	3	4	5	5	26	✓	1
	• Soyang Dam	n20	4	4	4	3	2	3	20		
	• Nuclear Warhd (Tobong San)	n30	3	2	3	3	3	3	17		
	• Nuclear Warhd	n60	3	2	2	3	2	1	13		
C ³ facility	• Army CP I	n46	4	3	5	5	4	4	25	✓	6
	• Army CP III	n58	4	3	4	5	4	3	23		
	• YangPeong Ant	n38	5	4	1	3	2	4	19		
	• Hongchen	n27	4	3	2	3	3	2	17		
Air-Defense	• Kimpo radar	n32	5	4	2	4	3	4	22	✓	1
	• Dongdu-Cheon	n13	5	3	4	3	4	5	24		
	• PyongTaek	n60	3	4	3	2	3	3	18		
	• OSAN ATOPCP	n53	5	4	5	3	3	4	24		
Logistical	• Dongducheon	n13	3	4	3	3	3	4	20	✓	2
	• Munition Stor.	n30	2	3	3	3	2	3	16		
	• POL terminal	n33	2	2	3	2	3	3	15		
	• Kimpo Int'l A/P	n32	3	5	4	4	5	4	25		
	• Incheon shipyrd	n37	1	4	2	3	3	5	18		

Table 10. CARVER Matrix for Objectives

As the result of this step, seven targets are initially acquired as the actual objectives for SOF. The location of available SOF units and the nodes in which each strategic target is located are the input data for Dijkstra's algorithm [Ref. 14], which provides an optimal route for SOF going to the target. The optimal route for attacking each target is:

- TGT 1 : n3 → n16 → n31 → n36 → n48 → n53
- TGT 2: n3 → n16 → n15 → n36
- TGT 3: n4 → n10 → n17 → n33 → n34
- TGT 4: n5 → n9 → n20 → n27 → n46
- TGT 5: n3 → n14 → n15 → n13
- TGT 6: n3 → n16 → n31 → n36 → n48 → n53
- TGT 7: n3 → n16 → n31 → n17 → n32

3. Application for Ingress Model

a. Results

A realization of this model was generated in a Quattro Pro spreadsheet using the @RAND uniform (0,1) random variable (see Table 11). These will be used to generate random times to detection.

TGT 1	TGT 2	TGT 3	TGT 4	TGT 5	TGT 6	TGT 7
.616242	.628517	.438637	.000705	.800862	.088452	.227944
.896274	.262704	.801132	.86741	.03031	.129744	.208652
.822213	.852173	.436588	.10950	.797058	.243018	.028634
.440744		.586867	.372901		.764904	.570498
.774021					.761593	

Table 11. Random Numbers Generated in Quattro-Pro

Two times are considered in the Ingress model: the transit time for a unit going from node i to node j and the simulated time to detect at least one unit going from i to j . The Ingress model determines detection from the three factors given in Table 5. The detection time, T_d , is compared to the arc travel time. If T_d is greater than the travel time, the SOF will not be detected. If shorter, it will be detected and returns to its base, using its original route with an assumed 20 percent reduction of its combat power.

The SOF team is assumed to move at night in the real world. The actual speed of movement depends on terrain type, SOF size and level of security. The Ingress model assumes that the SOF moves 32 km/day in open terrain, 24 km/day in mountain terrain, and 20 km/day in forest terrain. The detection rates are given in Table 6.

b. Analysis

In this model, every arc is independent of the other arcs. Thus, the condition of an arc that the SOF team previously passed has no effect on latter arcs in the optimal route. On each arc in the optimal route, the condition of terrain type, security level, and distance are different and the movement rate is based on these factors and the size of the team. The larger size team moves slower than the small team. Therefore, the results are based on a comparison using real time for movement from node i to node j and simulated detection time based on the Ingress model.

Tables 12 through 18 are the model results for the optimal routes to Target 1 through Target 7, respectively. If at each arc the Real Time is shorter than the detection (Sim) time, then the SOF team can traverse that arc without detection. But if it is longer, the SOF team will be detected and it must go back to its original base. The model assumes that because the SOF uses its ingress route and has accurate information about that route, it has only a 20 percent loss of combat power in egress, and the SOF can not be used for other missions during egress time. Thus, the Red force has a temporary decrease of SOF combat power during the egress period.

Arc (n3)	n16	n31	n36	n48	n53
Terrain Type	O	M	O	O	O
Security Level	H	H	L	L	L
Distance	40	15	38	22	18
Real Time	1.388	.735	1.25	.724	.592
Sim.Time	1.605	4.431	3.9	1.352	3.462

Table 12. Target 1 Data

Arc (n3)	n16	n31	n36
Terrain Type	O	M	O
Security Level	M	L	H
Distance	40	15	38
Real Time	1.56	.73	1.48
Sim.Time	1.08	.51	2.09

Table 13. Target 2 Data

Arc (n4)	n10	n17	n33	n34
Terrain Type	M	F	M	M
Security Level	H	L	H	L
Distance	43	35	38	18
Real Time	1.59	1.75	1.86	.789
Sim.Time	1.6	15.48	1.6	3.36

Table 14. Target 3 Data

Arc (n3)	n9	n20	n27	n46
Terrain Type	F	F	F	M
Security Level	H	H	L	L
Distance	38	29	31	47
Real Time	2.375	1.81	1.72	2.176
Sim. Time	.0614	2.92	.228	6.04

Table 15. Target 4 Data

Arc (n3)	n14	n15	n13
Terrain Type	O	M	M
Security Level	H	L	L
Distance	34	10	22
Real Time	1.03	.416	.816
Sim. Time	2.13	.141	.717

Table 16. Target 5 Data

Arc (n3)	n16	n31	n36	n48	n53
Terrain Type	O	M	O	O	O
Security Level	H	L	L	L	H
Distance	40	15	38	22	18
Real Time	1.47	.658	1.25	.724	.662
Sim. Time	.156	.390	.649	3.36	3.32

Table 17. Target 6 Data

Arc (n3)	n16	n31	n17	n32
Terrain Type	O	M	O	O
Security Level	H	L	H	L
Distance	40	15	17	23
Real Time	1.388	.625	.59	.718
Sim.Time	.60	.278	.068	1.96

Table 18. Target 7 Data

Figures 5 through 11 show the Posterior Comparison on Time to Targets 1 through 7, respectively.

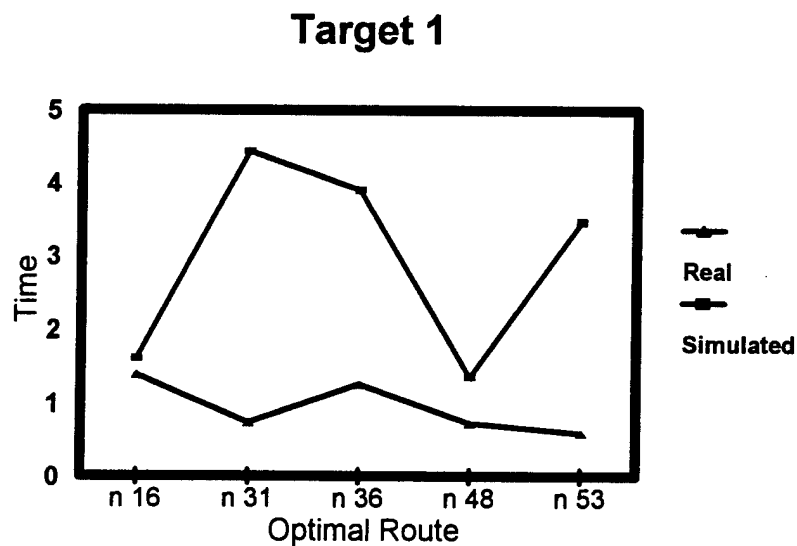

Figure 5. Posterior Comparison on Time to Target 1

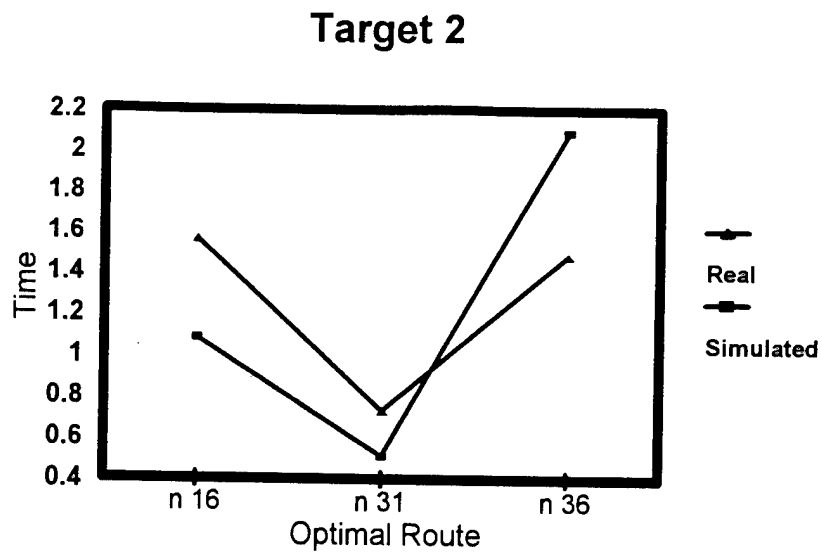

Figure 6. Posterior Comparison on Time to Target 2

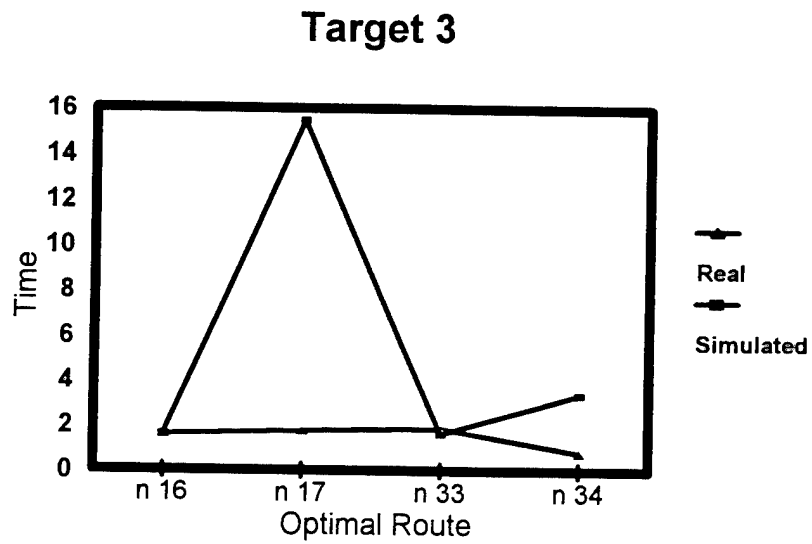

Figure 7. Posterior Comparison on Time of Target 3

Target 4

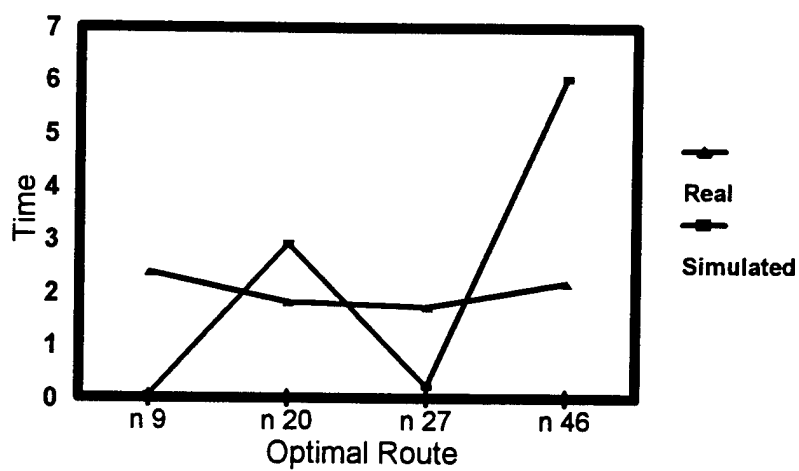

Figure 8. Posterior Comparison on Time to Target 4

Target 5

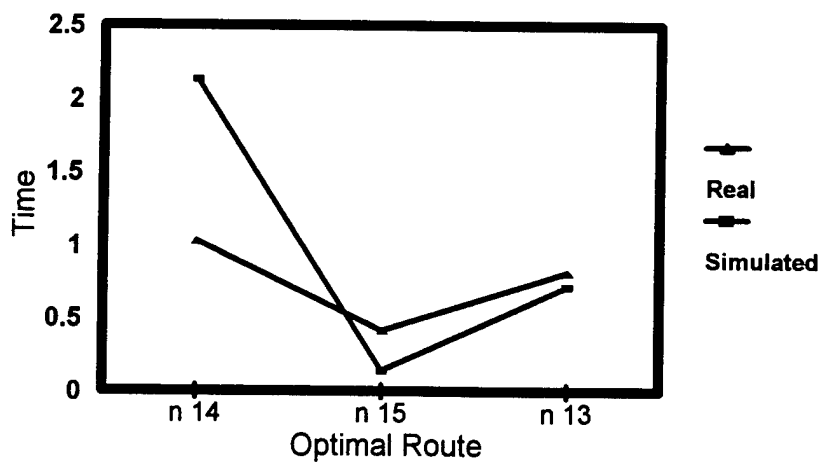

Figure 9. Posterior Comparison on Time to Target 5

Target 6

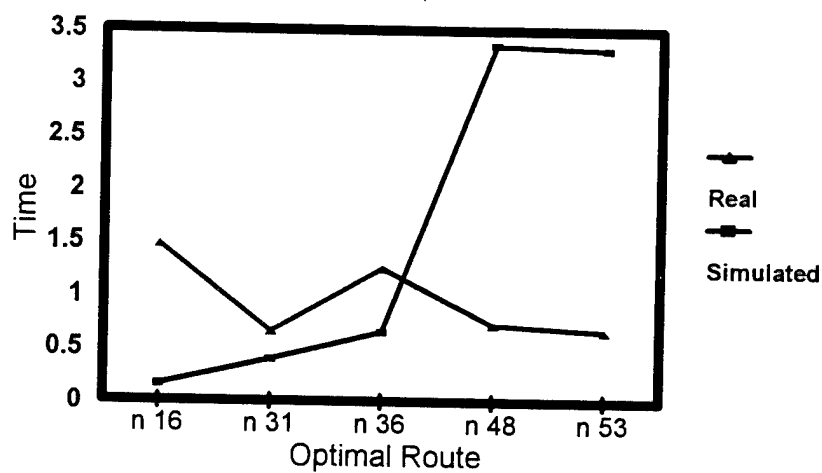

Figure 10. Posterior Comparison on Time to Target 6

Target 7

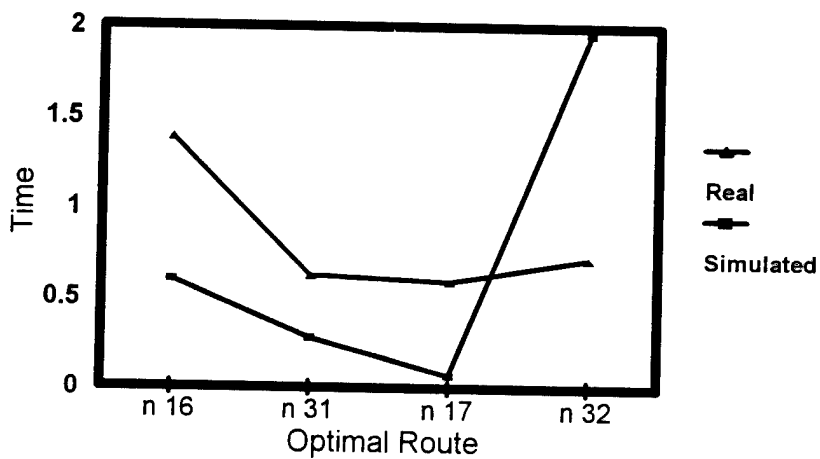

Figure 11. Posterior Comparison on Time to Target 7

Analysis for this replication:

- Target 1: This is an Air Base objective. The base is necessary for cooperation between the R.O.K. and the U.S. The optimal route to attack this target has 5 steps (arcs) from node 3 to node 53. At each arc, the real time of the SOF movement is always shorter than Sim-time. Thus, the SOF is not detected enroute to the objective.
- Target 2: This Target is an important government building at node 36, and requires a large size SOF. The optimal route has three steps. From Figure 6, the Sim-time is shorter than the real time at two nodes; therefore, it is detected and will return to base.
- Target 3: This is a dam for power and a reservoir for water. This mission can be done by a small size SOF. From Figure 7, even if the SOF is small, it will be detected on the first and third arcs; therefore, it will return to base.
- Target 4: This is the Command Post in a C³ facility and needs a large SOF for the destruction of its function. Figure 8 shows that the SOF cannot traverse its optimal route without detection.
- Target 5: This is an Air-defense Radar site, so it needs a small size SOF, but from Figure 9 and Table 5, it is likely to be detected by security force.

Target 6,7: These targets are an Air Force operational Command Post and the International Airport. From Figures 10 and 11, and Tables 17 and 18, the SOF Commander should adjust his mission and optimal route entirely if he wants to execute his mission without detection.

In actual application, this model would be run many times to estimate the probabilities of successful SOF ingress over the optimal routes.

4. Application of the Attrition Model

a. Result of the Infiltration Process

The current model applies the simple exponential distribution for the detection rate of the SOF by the target. This representation of the infiltration process is relatively simple and produces superficially realistic results. If a target is infiltrated successfully, the level of its functionality would go to zero because it is assumed that every undetected SOF team can accomplish its mission perfectly. If the SOF is detected by security units, the algorithm for combat is activated.

The results of the Ingress Model form the starting point for the infiltration model. From the example of the Korean War scenario and the Ingress Model results presented above, only target number 1 can be reached without detection. As a result, target number 1 is used in the infiltration model example to check the binary outcome: SOF mission success or security unit (combat) engagement.

Recall that

$$P[\text{det}] = 1 - e^{-\lambda T_s}$$
$$T_s = \frac{-\ln(1 - P[\text{det}])}{\lambda} \quad [4]$$

To evaluate $P[\text{det}]$, 0.68 is obtained using the @RAND function in Quattro-Pro. For target 1, the SOF used to attack the AFB is middle sized, and the security level is high.

Using these data for target number 1, the detection rate of 1.47 is obtained from Table 8. These values were estimated for purposes of this example in units of the total infiltration time; thus, the infiltration time T_i is 1.0. Using Equation 4 with $T_i = 1.0$ and $\lambda = 1.47$ yields a probability of detection of 0.77. Because 0.68 is less than 0.77, this SOF unit will be detected while infiltrating to the target and combat will result.

b. Results of the Combat Process

In Lanchester's model, the attrition rate is derived from high resolution combat interactions. Another NPS Master's Thesis is developing a high-resolution model for the combat between SOF and security forces. In this thesis, an aggregated rate is used based on the assumption that the SOF is well-trained for this mission, and the security unit is trained to be on a high alert for the protection of strategic targets. Normally the level of ability in personnel, information about the target and weapon systems are different between security units. In this case, the number of personnel in the SOF (1 team = 14 people) is 56 (4 teams); the security unit size is assumed to be proportional to the target size; in this case, 500 is assumed, as are the values for α and β .

$$\alpha = .001 \quad \beta = 1 \quad X_0 = 56 \quad Y_0 = 500$$

It is assumed that the SOF cannot accomplish its mission if it has less than one third of its original combat power; the security force will fight until it has only 25% survivors. In the proposed combat model, the mixed Lanchester model is applied:

$$\beta (X_0 - X_t) = \frac{\alpha}{2} (Y_0^2 - Y_t^2) \quad [5]$$

From this equation, if we assume that the SOF force breaks first,

$$X_t = 56/3 \quad Y_t = 418.7$$

If Y_t reaches a breakpoint before $X_t = \frac{1}{3}X_0$, then the SOF force will suffer less than 67 percent casualties. However, in this example, the SOF force breaks first, withdrawing from

the target area. If the SOF had won this combat, reducing the security force to its breakpoint, the SOF could have proceeded with its mission at its remaining capability level. But if the SOF team was defeated without unacceptable loss to security forces, the SOF's mission can be treated as a definitive failure. Therefore, at present, the loss to the SOF can be used to estimate the damage to the target. More detailed analysis of the damage affected by SOF is pending.

Finally, the damage level of each unit is:

MOE of Target damage = 0 %

MOE of SOF damage = $(56 - 56/3)/56 \times 100 = 66.7\%$

VII. SUMMARY AND FUTURE RESEARCH

A. SUMMARY

The purpose of this paper is to develop general methods to depict Special Force Operations in support of strategic objectives. Three models have been developed to provide an analytical approach to simulating SOF in theater-level models.

These models represent the initial research and implementation of special force operations in JWAEP. Although several parts of the model need more refinement and enhancement, and they are designed specifically for implementation of JWAEP, they still may be useful in a stand-alone mode or in connection with other models of joint warfare. This approach allows for more realistic investigations of special force operations in the new world order. It demonstrates priorities among possible targets and the process of selecting an optimal route in the Targeting model (Model I), the probability of successful SOF ingress in the Ingress model (Model II) and the probability of infiltration to target and analysis of potential combat attrition in the Attrition model (Model III). These models are capable of providing meaningful results in support of analysis of joint theater-level operations which account for uncertainty.

B. FUTURE RESEARCH

There are several parts in this area that need the additional research. Most of these parts are based on developing an aggregated model of high resolution events; but the high resolution representation is necessarily the cornerstone to aggregation.

1. Movements Rates for Each Size

The rate of movement at each unit is different. Generally, the smaller the size of SOF, the faster it goes. Because the data should be also updated by changes of weapons and SOF skill levels, the movement process needs more specific study based on a high resolution model.

2. Detection Over Multiple Arcs

The effect of security units was considered in the selection of arcs which the SOF used for its route. The security unit detection rate was aggregated and combined with other factors. As sensor systems develop, it may be possible for the sensors of a security unit to reach out over two or three arcs in the optimal route. This situation should be considered in a higher resolution model.

3. The Coefficient of Attrition Rate

This coefficient was estimated from historical data, based on the ability of SOF and security units and each weapon system; therefore, its value can be adjusted by new data. In this era of high technology, the capacity of SOF weapon systems increases, and the ability of a SOF team must be updated. The coefficient of attrition rate should be adjusted to incorporate the updated data.

4. Implementation of these Models into JWAEP

At present the network in JWAEP is limited to the arcs and nodes used by large units in aggregated combat. The initial model's network of 65 nodes and 132 arc for the Phase I in Korean War will need to be added to JWAEP. A larger SOF network is needed to represent the whole territory of Korea in JWAEP.

5. Damage to the Target

At present, the residual SOF force size is used as an estimator of partial SOF mission success. In reality, the damage to the target will be a random function based upon the size, equipment, training, etc. of the SOF and security forces; the time available to the SOF before detection, and the actual vulnerability of the target. Higher resolution models (under development elsewhere) may provide the necessary data to improve upon the target damage model outlined in this thesis.

APPENDIX A. LIST OF NODES FOR SOF NETWORK

node number	Key points	node number	Key points
1	Pyong Yang	34	Yang Seo - Ri
2	Ongjin	35	Seoul
3	Kaesong	36	Kwacheon
4	Pyonggang	37	Incheon
5	Mt. Kumkang	38	Yangpyong
6	Kansong	39	Kwang Ju
7	Mt. Daeam	40	Hajinbu
8	Mt. DaeSung	41	Mt. Balwang
9	Hwacheon	42	Mt. Karlwang
10	Chorwon	43	Saemal
11	Yeoncheon	44	Mt. Baedug
12	Hantan River	45	Mt. Chiock
13	Dongducheon	46	Won Ju
14	Munsan	47	Ansan
15	Bupwon Ri	48	Suwon
16	Kumcheon	49	Icheon
17	Rocheon	50	YeoJu
18	Kapyong	51	Nam Yang
19	Yanggu	52	Yongtn
20	Chuncheon	53	Osan
21	InJe	54	Samchuck
22	Sokcho	55	Sabook
23	Yangyang	56	Young Wae
24	Chumun Jin	57	Chechon
25	Mt. Ohdae	58	Kamgoek
26	Kangnung	59	Joam
27	Hongcheon	60	Songtan
28	Mt. Gyebang	61	Ansung
29	Castle Taegie	62	Yeopyongdo
30	Uijongbu	63	Dogjukdo
31	Koyang	64	Nacsan Sea
32	Kimpo	65	Samchuck Sea
33	Miegum		

APPENDIX B. ARC ATTRIBUTES AND LIST

A. ARC ATTRIBUTES

The route for SOF contains check-points for the force to maintain its route without error. Thus, the check-points are geographical features, which can be included as nodes. In this network for SOF, Arcs are drawn parallel to conventional mobility corridors, relative to mountains and cities, which are the nodes.

1. Distance

The distance of the arc between nodes is measured in kilometers, based on the contours of the terrain, the roads, and the arc direction.

2. Terrain

The attributes for terrain are classified into three categories: open, mountain, and forested area. This is based on the dominant factors in the area.

- open area * O
- mountain area . . . M
- Forest area F

*water is classified as open area.

B. LIST OF ARCS

<u>Arc Number</u>	<u>Arc</u>	<u>distance (km)</u>	<u>Terrain</u>	<u>Comment</u>
1	2 - 3	85		N. Korea area
2	2 - 63		O	sea route
3	2 - 64		O	sea route
4	3 - 14	33	O	DMZ
5	3 - 16	40	O	DMZ
6	4 - 8	39	M	DMZ
7	4 - 10	42	M	DMZ
8	4 - 11	41	M	DMZ
9	5 - 7	30	M	DMZ
10	5 - 9	35	F	DMZ

<u>Arc Number</u>	<u>Arc</u>	<u>distance (km)</u>	<u>Terrain</u>	<u>Security Unit</u>
11	6 - 22	30	O	R
12	6 - 64		O	
13	6 - 65		O	
14	7 - 19	21	M	D
15	7 - 21	17	M	R
16	8 - 9	26	M	R
17	8 - 10	30	O	
18	8 - 18	55	M	D
19	9 - 18	40	M	R
20	9 - 20	29	F	
21	10 - 17	35	F	R
22	11 - 12	16	M	BN
23	12 - 13	14	M	BN
24	12 - 14	36	M	
25	13 - 15	22	M	2BN
26	13 - 17	15	F	R
27	13 - 30	24	M	
28	14 - 15	10	M	R
29	14 - 16	11	O	BN

<u>Arc Number</u>	<u>Arc</u>	<u>distance (km)</u>	<u>Terrain</u>	<u>Security Unit</u>
30	15 - 16	15	M	R
31	15 - 30	25	F	R
32	16 - 31	15	M	2R
33	17 - 30	27	O	D
34	17 - 33	38	M	R
35	18 - 20	25	M	BN
36	18 - 33	40	O	
37	18 - 38	48	M	D
38	19 - 20	41	F	R
39	19 - 27	62	F	D
40	20 - 27	31	F	D
41	21 - 23	46	F	BN
42	21 - 27	62	M	D
43	21 - 28	60	M	R
44	22 - 23	19	O	
45	23 - 24	34	O	BN
46	23 - 25	40	M	R
47	24 - 25	32	M	BN
48	24 - 26	22	O	R
49	25 - 26	35	M	Co
50	25 - 28	12	F	
51	25 - 40	18	M	Co
52	26 - 40	38	M	BN
53	26 - 41	30	F	
54	26 - 54	51	M	R
55	27 - 28	67	F	
56	27 - 38	49	M	R
57	27 - 46	47	M	D
58	28 - 29	25	M	
59	28 - 40	19	O	
60	29 - 46	48	M	BN
61	30 - 31	22	M	D
62	30 - 33	21	O	BN

<u>Arc Number</u>	<u>Arc</u>	<u>distance (km)</u>	<u>Terrain</u>	<u>Security Unit</u>
63	30 - 35	24	O	Co
64	31 - 32	17	O	R
65	31 - 35	22	O,M	BN
66	31 - 36	38	O,F	Co
67	32 - 35	30	O,M	Co
68	32 - 37	23	O	PT
69	33 - 34	18	M	
70	33 - 35	25	O	Co
71	33 - 36	38	O,M	
72	34 - 38	20	O,M	R
73	34 - 39	20	O	
74	35 - 36	13	O	R
75	35 - 37	41	O	D
76	35 - 39	32	O	2R
77	36 - 39	30	O,M	Co
78	36 - 47	25	O	BN
79	36 - 48	22	O	R
80	37 - 47	30	O,M	BN
81	38 - 39	26	O	
82	38 - 46	52	M	R
83	38 - 50	30	M	BN
84	39 - 48	30	O	R
85	39 - 49	30	O	
86	39 - 52	24	O	R
87	40 - 41	17	M	
88	40 - 43	54	F,O	BN
89	41 - 42	21	F	
90	42 - 44	36	F	BN
91	42 - 55	43	F	
92	43 - 44	20	F	Co
93	43 - 46	14	O,M	R
94	44 - 45	22	M,F	BN
95	44 - 56	38	F	
96	45 - 46	4	O	BN

<u>Arc Number</u>	<u>Arc</u>	<u>distance (km)</u>	<u>Terrain</u>	<u>Security Unit</u>
97	46 - 50	35	M	BN
98	46 - 57	38	M,F	R
99	47 - 48	25	O	2R
100	47 - 51	18	O	
101	48 - 51	25	O	BN
102	48 - 52	20	O,M	
103	48 - 53	18	O	BN
104	49 - 50	20	O	
105	49 - 52	25	O,M	BN
106	49 - 58	25	O	R
107	50 - 58	18	O	
108	51 - 53	27	O,M	R
109	51 - 59	28	O	BN
110	52 - 53	17	O	BN
111	52 - 60	30	O,M	BN
112	52 - 61	31	O	Co
113	53 - 59	34	O	BN
114	53 - 60	15	O	
115	54 - 55	48	M	Co
116	55 - 56	38	M,F	BN
117	56 - 57	24	F	BN
118	57 - 58	65	F	R
119	58 - 61	39	O,M	R
120	59 - 60	30	O	BN
121	60 - 61	24	O,M	
122	62 - 32		sea-area	
123	62 - 37		sea-area	
124	62 - 47		sea area	
125	63 - 51		sea-area	
126	63 - 59		sea-area	
127	64 - 6		sea-area	

128	64 - 22	sea-area
129	64 - 23	sea-area
130	65 - 24	sea-area
131	65 - 24	sea-area
132	65 - 54	sea area

Legend

R:	Regiment	-2	
D:	Division	-1	
BN:	Battalion		-3
Co:	Company	-4	
PT:	Platoon	-5	

APPENDIX C. NETWORK FOR SOF

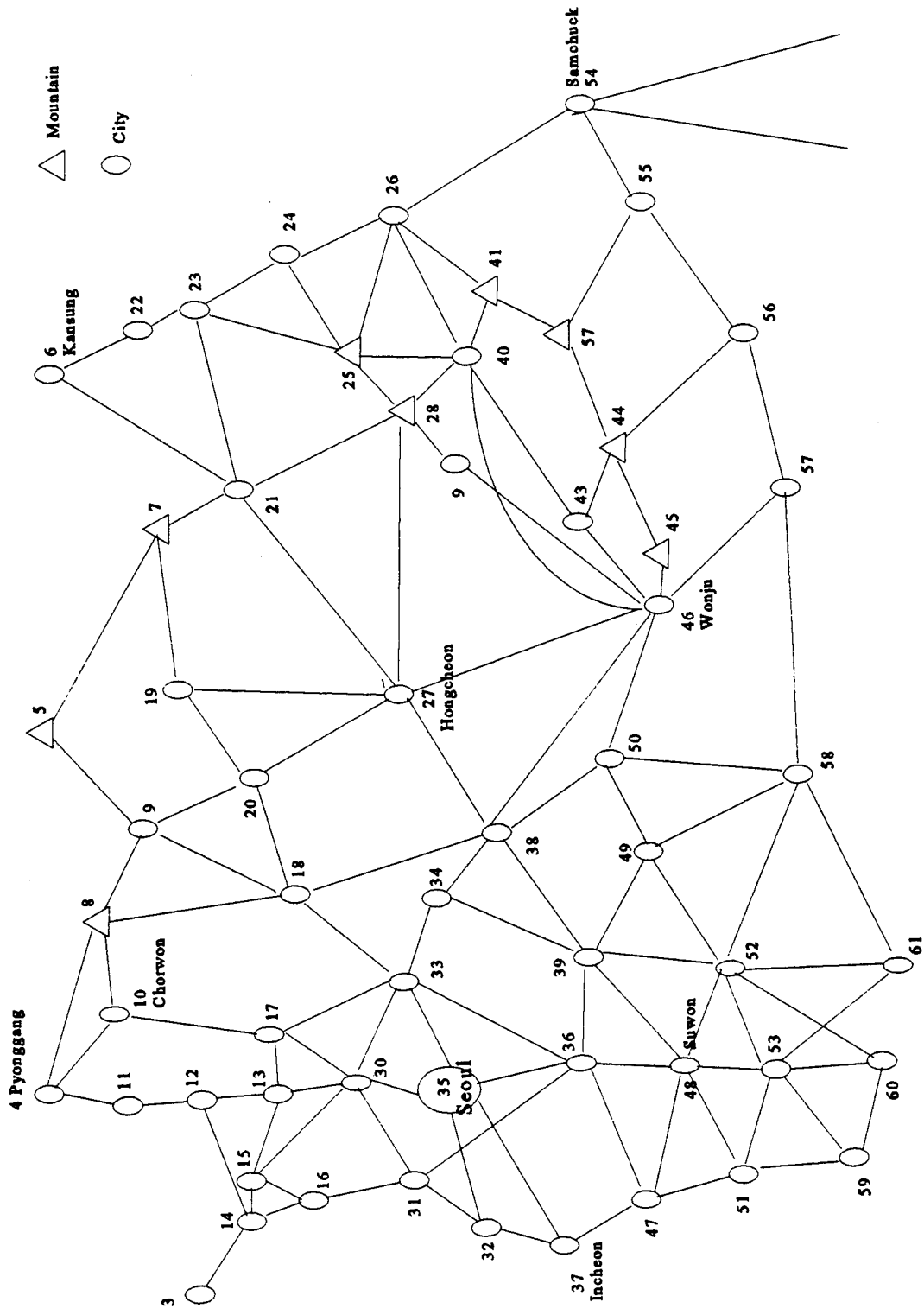

APPENDIX D. TEST SCENARIO (FOR POSSIBLE KOREAN WAR)

A. THE PURPOSE OF THE TEST SCENARIO

The purpose of the test scenario is to provide a feasible theater-level conflict scenario for the initial test of the three models. A Major Regional Contingency (MRC), recognized by military planners as a potential conflict, will be used in testing the model. The Korean MRC serves as the premise of the test scenario, though it was both scaled down and edited to provide a workable and unclassified test scenario.

Three possible attack courses of action (COA) that may be staged by the forces of North Korea, commonly termed the Democratic People's Republic of Korea (DPRK), were formulated. Three corresponding response COAs were designed for Allied forces. The purpose of designing three COAs is to ensure that targets are weighted by the COA being pursued and the commander's intent.

B. GROUND ARC-NODE NETWORK

The 65-node network for the Phase I of the Korean peninsula has 122 land arcs. The nodes primarily represent prominent cities located at intersection of avenues of approach, key terrains and lines of communication. Some nodes contain key terrain, air bases, logistical bases, defensive battle positions, assembly areas, and terrain oriented objectives. The network also extends into the adjacent bodies of water surrounding the peninsula to facilitate naval air and SOF needs. A complete list of nodes and their locations is found in Appendix A.

Chapter IV contains the complete discussion of attributes of the arcs (transit nodes) in the network. A list of the arcs associated with the 65-node Korean peninsula network and the key outlining the arc attributes are found in Appendix B.

C. TEST SCENARIO

1. Classification

The test scenario is based on events in the Korean theater of operations and is designed to be somewhat realistic. The force structures and operational plans for both sides of the conflict have been designed using force sizes, identifications, locations, plans, and missions that are plausible yet purposely incorrect, in order for this study to remain unclassified.

2. Terrain Description

The Korean peninsula is contiguous to both the former Soviet Union and China and stretches roughly 1000 kilometers south of the Asian continental land mass. Fifty-five percent of the 221,487 square kilometers is north of the Demilitarized Zone (DMZ). The DMZ is four kilometers wide and extends 241 kilometers from the Yellow Sea in the west to the Sea of Japan in the east.

The terrain of South Korea (ROK) is diverse with great mountain ranges in the east and many river basins in the west and central portions of the country. Two of the greatest mountain ranges are the Taebaek Range, running north-south along the eastern coast line, and the intersecting Sobaek Range, which runs roughly northeast-southwest in the central region of the land mass. These two mountain ranges, along with the Nangnimsan Range, divide the country's eastern and western sides. Running north from the vicinity of Masan along the southeast coast is the Naktong Basin which provides flat to rolling terrain. The entire western portion of the country is a succession of basins, with the exception of the Haryong Mountain Range, creating a large mobility corridor extending north-south.

As discussed above, the country is divided by the north-south mountain ranges. Along the eastern coast line is a very narrow mobility corridor that reaches the southern most point of the peninsula from the DMZ. The entire western region of South Korea is essentially a mobility corridor expanding south from the DMZ, through Seoul and Chonju, to Kwangju in the southwest.

Smaller noteworthy mobility corridors cross the specific terrain along the DMZ. In the east is the narrow corridor along the coast. In the west there are three notable corridors extending south into Seoul and the surrounding lowlands. First, to the far west is a path from Kaesong crossing the DMZ. Second, adjacent to the east, is a corridor through the North Korean town of Pyongyang stretching to Seoul, and third, in the center of the DMZ, is a mobility corridor through Kimhwa in the north extending into the vicinity of Seoul.

3. DPRK Force Structure

The DPRK ground forces are comprised of both conventional and special operations forces. The conventional forces are formed into four corps organizations, totaling 16 corps. The four different corps organizations are comprised of two versions of relatively balanced numbers of armored and mechanized infantry brigades and two versions of light infantry units. Twenty-one 1000 man battalions make up the entirety of the special operations forces (SOF).

The DPRK aviation assets are comprised of 50 MI-24 HIND helicopters and 25 regiments of combat fixed-wing aircraft. There are 12 fighter air attack regiments of 376 aircraft, one half of which are versions of the Soviet MIG. Ten fighter ground attack regiments have 346 aircraft, the majority of which are quite antiquated. Finally, there are three light bomber regiments with 80 aircraft.

The DPRK Naval assets are inconsequential relative to ours. The preponderance of naval forces will be used in support of DPRK SOF operations.

4. Allied Force Structure

The Allied forces are comprised of United States (US) and Republic of Korea (ROK) units. The US forces are organized by service and specific unit designation. There is an additional descriptor that categorizes the US units. The US contingent is broken down into Initial Forces (IF) and Reinforcing Forces (RF). Initial Forces are those that Allied planners deem necessary to conduct a successful defense of the Korean peninsula while Reinforcing Forces are those that make up the significant difference in the force structure

allowing for counter-offensive operations. The ROK Army will field ten divisions and 15 separate brigades. Two US mechanized brigades (stationed in South Korea) will join ten armor brigades and four mechanized brigades from among the 15 separate ROK brigades to form the ROK Corps responsible for counter-offensive operations.

The US Initial Forces are comprised of units from all four services with both conventional and special operations forces. Four divisions and an armored cavalry regiment make up the Army contingent while the Air Force furnishes 16 squadrons, six bomber and ten fighter. Two carrier battle groups (CVBG) from the Navy will join four Marine Expeditionary Brigades and a Marine Expeditionary Unit. Lastly, the Army, Navy and Air Force will provide special operations forces.

The US Reinforcing Forces have two Army divisions, 15 Air Force fighter squadrons, and two carrier battle groups. [Ref. 16]

5. Engagement Conventional Goals and Objectives for Complete Implementation of the Proposed Korean Scenario

a. Phase I

1. Envelopment and partial destruction of Seoul
2. Seize Objective (OBJ) Suwon-Osan (airfields)
3. Seize OBJ Kangnung
4. Destruction of forces north of Phase Line 1 (PL1)

b. Phase II

1. Seize OBJ Chungju (road junctions)
2. Seize OBJ Kongju-Taeju (road junctions)
3. Seize OBJ Kunsan (air/sea ports)
4. Seize OBJ Yeongdeog (road junctions)
5. Destruction of forces north of PL2

c. Phase III

1. Seize OBJ Kimchun-Taegu (road junctions)
2. Seize OBJ Kwangju (airport/C2/Logistics)
3. Seize OBJs Pusan and Pohang (sea ports)
4. Destruction of all Allied forces on the peninsula

6. SOF Goals and Objectives

a. Destroy all significant power and communication facilities throughout the theater.

b. Reduce effectiveness of airfields at Suwon and Osan.

c. Reduce effectiveness of airfields and sea ports at Kunsan.

d. Disrupt off-loading operations at ports in Pusan and Pohang.

LIST OF REFERENCES

1. J. Blackwell, M.J. Mazarr and D. M. Snider. "The Gulf War: Military Lessons Learned," The Center for Strategic and International Studies, Washington, D.C., July 1991.
2. Wilson, Greg, "Modeling and Evaluating U.S. Army Special Operations Forces Combat Attrition Using JANUS," Master's Thesis, Naval Postgraduate School, CA, September 1995.
3. Defense Intelligence Agency, "North Korea," June 1993.
4. TRAC-OAC, TACWAR-Ground Analyst Guide, Version 4.0B, Fort Leavenworth, KS, February 1994.
5. Louisiana Maneuvers Task Force, "Models, Simulations and Tools," HQ of Army, May 1993.
6. Hartman, J.K., S. H. Parry, W. J. Caldwell, "Airland Combat Models II Aggregated Combat Modeling, Naval Postgraduate School," Monterey, CA, December 1992.
7. Collins, John M., "Special Operations Forces," National Defense University Press, Washington, DC, April 1994.
8. Headquarters of Army, FM 101-5, "DOD Dictionary - Operational Terms and Symbols," Department of Army, DC, October 1985.
9. Bennett, B., S. Gardiner, D. Box and N. Witney, "Theater Analysis and Modeling in an Era of Uncertainty: The Present and Future of Warfare," RAND, 1994.
10. Hartman, J. K. S. H. Parry, W. J. Caldwell, "Airland Combat Models I: High Resolution Combat Modeling," Naval Postgraduate School, December 1992.
11. Youngren, Mark A., "The Joint Warfare Analysis Experimental Prototype (JWAEP) - User Documentation Draft (Ver. 1.0)," Naval Postgraduate School, November 1994.
12. USSOCOM, "Joint Special Operations Awareness Program (JSOAP) - Reference Manual," Kapos Associates, Inc., July 1994.
13. Headquarters, Department of Army, FM 31-20, "Doctrine for Special Forces Operations," Special Warfare Center and School, Ft Brag, NC, April 1990.

14. Ahuja, Magranti, Orlin, "Network Flows, Theory, Algorithm and Applications," Prentice Hall, Eaglewood Cliffs, NJ, 1993.
15. Youngren, Mark A., "Physical Presentation, Arc-Node Network," CFAD, J-8, The Joint Staff, July 1992.
16. Schmidt, Karl M., "Design Methodology for Future Theater Level Model (FTLM)," Master's Thesis, Naval Postgraduate School, CA, September 1993.
17. Rubinstein, Reuven Y., "Monte Carlo Optimization, Simulation and Sensitivity of Queueing Networks," John Wiley and Sons, Inc., New York, 1986.
18. Marshall, K. T., R. M. Oliver, "Decision Making and Forecasting with Emphasis on Model Building and Policy Analysis," McGraw-Hill, Inc., New York, 1995.
19. Fulkerson, M.B., Jr., "Integration of Naval Forces into the Early Entry Theater Level Model (EETLM)," Master's Thesis, Naval Postgraduate School, CA, September 1994.
20. Taylor, James G., "Lanchester Models of Warfare," Vol 1, Naval Postgraduate School, March 1983.
21. Perla, Peter, "The Art of Wargaming," Naval Institute Press, Annapolis, Maryland, 1990.
22. Law, A. M., W. D. Kelton, "Simulation Modeling and Analysis," McGraw-Hill, Inc., NY, 1991.
23. Ministry of Defense of Republic of Korea, "Defense White Paper," Seoul, 1995.

INITIAL DISTRIBUTION LIST

	No. Copies
1. Defense Technical Information Center Cameron Station Alexandria, Virginia 22304-6145	2
2. Library, Code 52 Naval Postgraduate School Monterey, California 93943-5002	2
3. Professor Sam Parry (Code OR/Py) Naval Postgraduate School Monterey, CA 93943-5000	5
4. Professor Mark Youngren (Code OR/Ym) Naval Postgraduate School Monterey, CA 93943-5000	10
5. Professor So-Young, Sohn Department of Decision Science and Engineering Systems Rensselaer Polytechnic Institute Troy, NY 12180-3590	1
6. Woodang Library Nowon-Gu, Gongneung-Dong P.O. Box 77 Korea Military Academy Seoul, Korea 139-799	1
7. Lt. Col. Park Bong Suk Department of Personnel Education Nonsam-Kun, Dooma-myun, Boonamri, P.O.B. 4 Republic of Korea 320-919	1

8. Lim, Chong Kwon
Sansung-Dong 74-1
Kong Ju-Shi, Chung cheong Nam-Do
Republic of Korea 310-30

2