

NAVAL POSTGRADUATE SCHOOL MONTEREY, CALIFORNIA



THESIS

**INTEGRATION OF SYSTEMS MANAGEMENT
DEPARTMENTS 0TR, 4TR AND 8TR TOKEN
RING LOCAL AREA NETWORKS**

by

Patrick J. McGillvray

September, 1995

Thesis Advisor:

Norman Schneidewind

Approved for public release; distribution is unlimited

19960226 133

REPORT DOCUMENTATION PAGE

Form Approved OMB No. 0704-0188

Public reporting burden for this collection of information is estimated to average 1 hour per response, including the time for reviewing instruction, searching existing data sources, gathering and maintaining the data needed, and completing and reviewing the collection of information. Send comments regarding this burden estimate or any other aspect of this collection of information, including suggestions for reducing this burden, to Washington Headquarters Services, Directorate for Information Operations and Reports, 1215 Jefferson Davis Highway, Suite 1204, Arlington, VA 22202-4302, and to the Office of Management and Budget, Paperwork Reduction Project (0704-0188) Washington DC 20503.

| | | | |
|---|--|---|----------------------------------|
| 1. AGENCY USE ONLY <i>(Leave blank)</i> | 2. REPORT DATE September 1995 | 3. REPORT TYPE AND DATES COVERED Master's Thesis | |
| 4. TITLE AND SUBTITLE INTEGRATION OF SYSTEMS MANAGEMENT DEPARTMENTS 0TR, 4T4, AND 8TR TOKEN RING LOCAL AREA NETWORKS | | 5. FUNDING NUMBERS | |
| 6. AUTHOR(S) McGillvray, Patrick John | | 8. PERFORMING ORGANIZATION REPORT NUMBER | |
| 7. PERFORMING ORGANIZATION NAME(S) AND ADDRESS(ES) Naval Postgraduate School Monterey CA 93943-5000 | | 10. SPONSORING/MONITORING AGENCY REPORT NUMBER | |
| 9. SPONSORING/MONITORING AGENCY NAME(S) AND ADDRESS(ES) | | 11. SUPPLEMENTARY NOTES The views expressed in this thesis are those of the author and do not reflect the official policy or position of the Department of Defense or the U.S. Government. | |
| 12a. DISTRIBUTION/AVAILABILITY STATEMENT Approved for public release; distribution is unlimited. | | 12b. DISTRIBUTION CODE *A | |
| 13. ABSTRACT <i>(maximum 200 words)</i> There are few more significant topic in todays IT world than the integration of disparate, application specific, physically seperated networks into integrated systems. These "islands of auotmation" networks are unable to share data or resources, thereby promoting duplication of both. This duplication wastes man-hours and money. In today's climate of downsizing and streamlining in government and the military, this is unacceptable. This study will plan and implement the integration of three such networks of the Systems Management Department of the Naval Postgraduate School. Integrating the LAN laboratoies will provide for improved utilization of resources, increased reliability and uniform access to all network resources regardless of the users physical location. Moreover this study will provide an "in the trenches' perspective of LAN integration. | | | |
| 14. SUBJECT TERMS Local Area Network; Token Ring Architecture; Network Integration; | | 15. NUMBER OF PAGES 92 | 16. PRICE CODE |
| 17. SECURITY CLASSIFICATION OF REPORT Unclassified | 18. SECURITY CLASSIFICATION OF THIS PAGE Unclassified | 19. SECURITY CLASSIFICATION OF ABSTRACT Unclassified | 20. LIMITATION OF ABSTRACT UL |

NSN 7540-01-280-5500

Standard Form 298 (Rev. 2-89)
Prescribed by ANSI Std. Z39-18 298-102

Approved for public release; distribution is unlimited.

**INTEGRATION OF SYSTEMS MANAGEMENT
DEPARTMENTS 0TR, 4TR, AND 8TR
TOKEN RING LOCAL AREA NETWORKS**

Patrick J. McGillvray
Lieutenant, United States Coast Guard
B.S., Capitol College, 1985

Submitted in partial fulfillment
of the requirements for the degree of

**MASTER OF SCIENCE IN INFORMATION TECHNOLOGY
MANAGEMENT**

from the

**NAVAL POSTGRADUATE SCHOOL
September 1995**

Author:

Patrick J. McGillvray

Approved by:

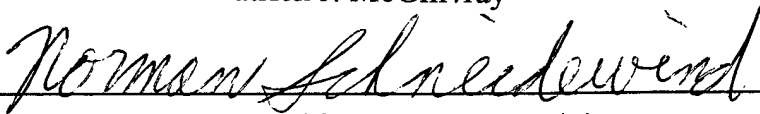

Norman Schneidewind, Thesis Advisor

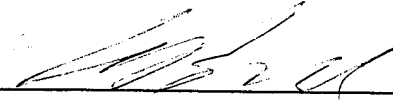

Rex Buddenberg, Second Reader

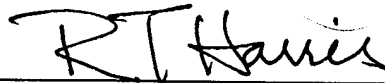

Reuben T. Harris, Chairman
Department of Systems Management

ABSTRACT

There are few more significant topic in todays IT world than the integration of disparate, application specific, physically separated networks into integrated systems. These "islands of automation" networks are unable to share data or resources, thereby resulting in the duplication of both. This duplication wastes man-hours and money. In today's climate of downsizing and streamlining in government and the military, this is unacceptable.

This study will plan and implement the integration of three such networks of the Systems Management Department of the Naval Postgraduate School. Integrating the LAN laboratories will provide for improved utilization of resources, increased reliability and uniform access to all network resources regardless of the users physical location. Moreover this study will provide an "in the trenches' perspective of LAN integration.

TABLE OF CONTENTS

| | |
|-------------------------------------|----|
| I. INTRODUCTION | 1 |
| A. OBJECTIVES | 1 |
| B. RESEARCH QUESTIONS | 1 |
| C. METHODOLOGY | 2 |
| 1. Literature Review | 2 |
| 2. System Planning | 3 |
| 3. Hands-on Experience | 3 |
| D. CHAPTER SUMMARY | 3 |
| II. BACKGROUND | 5 |
| A. DEFINITION OF TERMS | 5 |
| 1. Networks | 5 |
| 2. Network Nodes | 5 |
| 3. Network Hardware | 6 |
| 4. Network Software | 7 |
| B. HISTORY | 7 |
| 1. I-224 Networks Lab | 7 |
| 2. I-250 Decision Support Lab | 7 |
| 3. I-158 Software Metrics Lab | 8 |
| C. EVOLUTION | 8 |
| D. PRESENT CONFIGURATION | 8 |
| 1. Topology | 9 |
| 2. Physical Separation | 9 |
| 3. Hardware | 10 |
| 4. Software | 10 |
| E. HUMAN RESOURCES | 10 |
| F. REQUIREMENTS | 11 |

| | | |
|------|-----------------------------------|----|
| 1. | User Requirements | 11 |
| 2. | SM Department Network Plans | 11 |
| 3. | SM LAN Administration Goals | 12 |
| G. | CHAPTER SUMMARY | 12 |
| | | |
| III. | INTEGRATION PLANNING | 13 |
| A. | APPLICATION SOFTWARE ASSESSMENT | 13 |
| 1. | Software Location | 13 |
| 2. | Hard Disk Storage Requirements | 15 |
| B. | HARDWARE ASSESSMENT | 15 |
| 1. | Pentium Servers | 15 |
| 2. | Print Servers | 16 |
| C. | DRIVE MAPPING | 16 |
| 1. | Software Migration Strategy | 17 |
| 2. | Directory Tree Pruning | 17 |
| 3. | Integrated Network Directory Maps | 18 |
| D. | SYSTEM FILE REVISION | 19 |
| 1. | Memory Management | 19 |
| 2. | CONFIG.SYS (Server) | 20 |
| a. | File Modifications | 22 |
| 3. | CONFIG.SYS (User Computer) | 22 |
| 4. | AUTOEXEC.BAT (Server) | 23 |
| a. | File Modifications | 25 |
| 5. | AUTOEXEC.BAT (User Computer) | 25 |
| a. | File Modifications | 26 |
| 6. | START.BAT | 26 |
| a. | File Modifications | 29 |
| E. | PHYSICAL CONNECTION | 29 |
| F. | TESTING | 29 |

| | |
|--|----|
| 1. 8TR Test-bed | 29 |
| 2. Integrated LAN Testing | 30 |
| G. CHAPTER SUMMARY | 32 |
| | |
| IV. RESULTS, CONCLUSIONS AND RECOMMENDATIONS | 33 |
| A. RESULTS | 33 |
| 1. Physical Connection | 33 |
| 2. Logical Connection | 34 |
| 3. Hardware | 35 |
| 4. Application Software | 36 |
| B. CONCLUSIONS | 36 |
| C. RECOMMENDATIONS | 37 |
| 1. Hardware | 37 |
| 2. Software | 38 |
| 3. Personnel | 38 |
| 4. Life Cycle Support | 39 |
| D. SUMMARY | 40 |
| | |
| INITIAL DISTRIBUTION LIST | 79 |
| APPENDIX A. LAN DIAGRAMS | 41 |
| APPENDIX B. HARDWARE TABLES | 43 |
| APPENDIX C. EXISTING SERVER DIRECTORY MAPS | 47 |
| APPENDIX D. PENTIUM SERVER DIRECTORY MAPS | 55 |
| APPENDIX E. UPDATED SYSTEM FILES | 61 |
| APPENDIX F. LAN CABLING MAP | 69 |
| APPENDIX G. INTEGRATED LAN DIAGRAM | 73 |
| LIST OF REFERENCES | 75 |
| INITIAL DISTRIBUTION LIST | 77 |

LIST OF FIGURES

| | |
|---|----|
| 1. Token Ring Example | 9 |
| 2. Network Logical Drive | 17 |
| 3. CONFIG.SYS file for PN3 | 21 |
| 4. CONFIG.SYS file for User Computer TN32 | 23 |
| 5. AUTOEXEC.BAT file for PN3 | 24 |
| 6. AUTOEXEC.BAT file for User Computer TN32 | 25 |
| 7. START.BAT file for User Computer | 27 |
| 8. RENAME Batch Files | 31 |

LIST OF TABLES

| | |
|---------------------------------|----|
| 1. Installed Software | 14 |
| 2. Five Year Support Plan | 39 |

I. INTRODUCTION

There are few more significant topics in organizations today than the importance of information systems and the means to combine disparate, application specific, physically separated networks into an integrated system. These "islands of automation" networks are unable to share data or resources, thereby resulting in duplication of both. This duplication wastes man-hours and money. In today's climate of downsizing and streamlining in government and the military, this is unacceptable.

This study will provide an analysis of local area network (LAN) integration, the purpose being to plan and implement the integration of three such networks in the Systems Management Department of the Naval Postgraduate School (NPS).

A. OBJECTIVES

This study will plan and implement the *physical* and *logical* integration of the three Systems Management Departments LAN laboratories in I-158, I-250 and I-224. *Physical* integration is accomplished by physically connecting the three networks together. How the actual physical connection is made is dependent on a number of factors; that is, media and signaling systems used in the individual networks, distance separating the networks and network traffic loading factors. A more detailed discussion of physical connection methods will be discussed in Chapter IV. *Logical* integration is accomplished through software. Critical network files must be rewritten to allow the user access to all network resources: for example, servers, printers, data and applications, independent of the users' physical location.

B. RESEARCH QUESTIONS

To attain the objective of this thesis, and prior to implementing any change in an organization's network structure, [Katzan] observes it is essential to establish three criteria:

- What is the current position of the network? Current position is a determination of installed equipment, network topologies and use of the network.

- What are the goals of the network management? What new position are they striving for?
- What is the direction or plan to move from the current position? What are the alternatives and constraints to achieving those goals?

These criteria can be broken down into the following questions:

- What is the state of the existing networks? This would include installed hardware and software characteristics of the network, primary uses and shortcomings of the network and the workload of the network staff.
- What are the goals and constraints of the network management? These goals might be increased performance, functionality and reliability, while the constraints might be funding and staff.
- How will these goals affect the life cycle “costs of ownership” of the network?
- What are the alternatives to achieving managements goals? Can the goals be accomplished using some of the installed base of hardware and software, or will one or both have to be replaced?
- What future changes in the NPS organization’s strategic network plans would affect Systems Management LAN managements goals?

C. METHODOLOGY

1. Literature Review

Current trade magazines and professional journals provided insight into network integration and management issues in general. Prior to any integration effort, it is essential to become thoroughly familiar with the current hardware, software and architecture of the networks. Vendor documentation and third-party publications provided a thorough understanding of the installed hardware, network and application software, memory management and token-ring architecture.

2. System Planning

Analysis, design and implementation processes for the integrated network followed a conventional sequence proven successful for computer-based systems. [Abrahams] lists seven major steps as follows:

- Needs analysis
- Site planning
- Detailed system design
- Hardware installation and testing
- Software loading and validation
- System implementation and user training
- Post implementation audits and system training

3. Hands-on Experience

Hands-on work as LAN lab assistant during the integration effort provided valuable experience and insight on network management issues. Working with the LANs provided an accurate assessment of the present condition of the networks. Day-to-day interaction with users and management provided insights into the needs and goals of both parties.

D. CHAPTER SUMMARY

This thesis will plan and implement the physical and logical integration of the Systems Management LAN laboratories. It will also offer recommendations for continued improvements to the integrated LAN. Moreover it will provide a “nuts and bolts” look at the details of LAN integration.

The next chapter will provide a brief history of the evolution of the System Management LANs. It will review terms and concepts that lay the foundation for the following chapters. Subsequent chapters will address research questions as they apply generically to network integration and specifically to the integration of the Systems Management LANs.

II. BACKGROUND

This chapter reviews terms and concepts necessary for understanding discussions in subsequent chapters, provides a brief history of the evolution of the Systems Management Department's LANs and provides a description of topology, hardware and software of the LANs prior to the integration. Network maps depicting network configuration prior to integration are provided in Appendix A.

A. DEFINITION OF TERMS

This section reviews some terms and concepts necessary for understanding discussions in this, and subsequent chapters. It is not intended as a dictionary for all the LAN terms, but for those specific to the Systems Management Department's LANs. [Feibel] provides thorough descriptions of LAN terms and concepts for further reading.

1. Networks

- 0TR - Token Ring network in I-250
- 4TR - Token Ring network in I-224
- 8TR- Token Ring network in I-158

2. Network Nodes

- PN3 - Pentium Network server 3. Node designation for IBM Pentium server computer on the Token Ring network 0TR.
- PN6 - Pentium Network server 6. Node designation for IBM Pentium server computer on the Token Ring network 4TR.
- N3 - 486DX33 Network server 3. Node designation for BI-LINK PC server computer on the Token Ring network 0TR.
- N6 - 486DX33 Network file and printer server 6. Node designation for BI-LINK PC server computer on the Token Ring network 0TR.

- TN3 - 486DX33 Network server 3. Node designation for BI-LINK PC server computer on the Token Ring network 4TR.
- TN6M - 486DX33 Network file and printer server 6. Node designation for BI-LINK PC server computer on the Token Ring network 4TR.
- TN4 - 486DX266 Network server 3. Node designation for Data Store PC server computer on the Token Ring network 8TR.
- Nxx (i.e. N11) - Network node xx. Node designation for a user computer on the Token Ring network 0TR.
- TNxx (i.e. TN11) - Network node xx. Node designation for a user computer on the Token Ring network 4TR and 8TR.
- Primary Server - A server computer that is set up for day-to-day support of the network.
- Secondary Server - A server computer that is brought up on the network when a primary server fails.

3. Network Hardware

- Network Interface Card (NIC) -An NIC, or network adapter card, is installed in the user and server computers. It provides an interface from these nodes to the network.
- Multiple Access Unit (MAU) - A MAU is IBM's term for a wiring hub in its Token Ring architecture. This hub serves as the termination point for multiple nodes and can be connected to the network or to another MAU. [Feibel]
- Adapter Cable - Adapter Cable has an IBM data connector at one end and a nine-pin connector on the other. It is used to connect user computer and server NIC's to other network components that use IBM data connectors (i.e. MAUs).
- Patch Cable - Patch cables have IBM data connectors on both ends and are used to connect a PC to a MAU when the token ring adapter cable cannot reach the MAU. One end of the patch cable is connected to the adapter cable and the other end to the MAU. Patch cables come in standard lengths of 8, 30, 75, and 150 ft. Patch cables are also used to interconnect MAUs.

4. Network Software

- Disk Operating System (DOS) - Responsible for managing the PC's local resources (i.e. disk drives, monitors, keyboards and monitors).
- Network Operating System (NOS) - Responsible for processing requests from user computers, for maintaining the network and for controlling the services and devices available to the user.
- Network Basic Input Output System (NETBIOS) - Device drivers files that provide for sessions between applications and the network by name (e.g. between user NORM requesting an application program from server TN3). [Schneidewind1]
- Batch Files - Text files that contain DOS commands. When DOS executes a batch file, it executes the commands in the file in the order they appear. AUTOEXEC.BAT is an example.
- Windows - a graphical user interface (GUI) that runs on top of DOS in the user computers.
- Application Programs - Wordprocessors, spreadsheets and database programs.

B. HISTORY

In 1985, The Chief of Naval Operations (CNO) provided NPS with \$3.5M to build labs for student and faculty research. The Systems Management Department, (formerly the Administrative Science Department) obtained \$400K to install computer labs.

Historically, the three Systems Management Department's LANs in I-224, I-250 and I-158 were planned and implemented for different purposes. [Schneidewind2]

1. I-224 Networks Lab

The primary purpose of the Networks Lab was to provide multi-network technology to support the Information Technology Management (ITM) curriculum.

2. I-250 Decision Support Lab

The primary purpose of this lab was to provide a homogeneous network to support computer literacy for the Systems Management curriculum. Later, there was a shift in emphasis to decision support applications.

3. I-158 Software Metrics Lab

The primary purposes of the Software Metrics Lab is to support software measurement research and to serve as a test bed for new hardware and software prior to making them available to the I-250 and I-224 labs.

C. EVOLUTION

Over the past nine years the SM LAN hardware has evolved from Intel 8088 based IBM PCs and XT's, to 80286 AT's to the 80486 PCs installed today. In I-250 the architecture started out as Broadband Ethernet, and then to 4Mbs Token Ring and finally to 16Mbs Token Ring. In I-224 the architecture started out as 4Mb Token Ring and then to 16Mbs Token Ring. In addition, a Baseband Ethernet and an Apple network were installed in I-224. Subsequently the Apple network was removed from I-224, and an upgraded version was installed in I-158.

Software has also evolved through the years. Both the DOS and NOS have gone through various upgrades. User demand for GUI's has shifted the application software from primarily DOS based, to Windows based programs. These Windows applications have put tremendous strain on resources, both human and network. For example, WordPefect for Windows 6.1 consumes over 27Mb of storage and takes hours to install on the server and user computers.

D. PRESENT CONFIGURATION

Network configuration consists of the equipment, connections (physical and logical) and settings in effect for a network at a particular time. Equipment, can refer to both hardware (i.e., user computers, printers and cabling) as well as software (applications, DOS, Windows and NOS). The following subsections describe the configuration of the three SM LANs prior to integration.

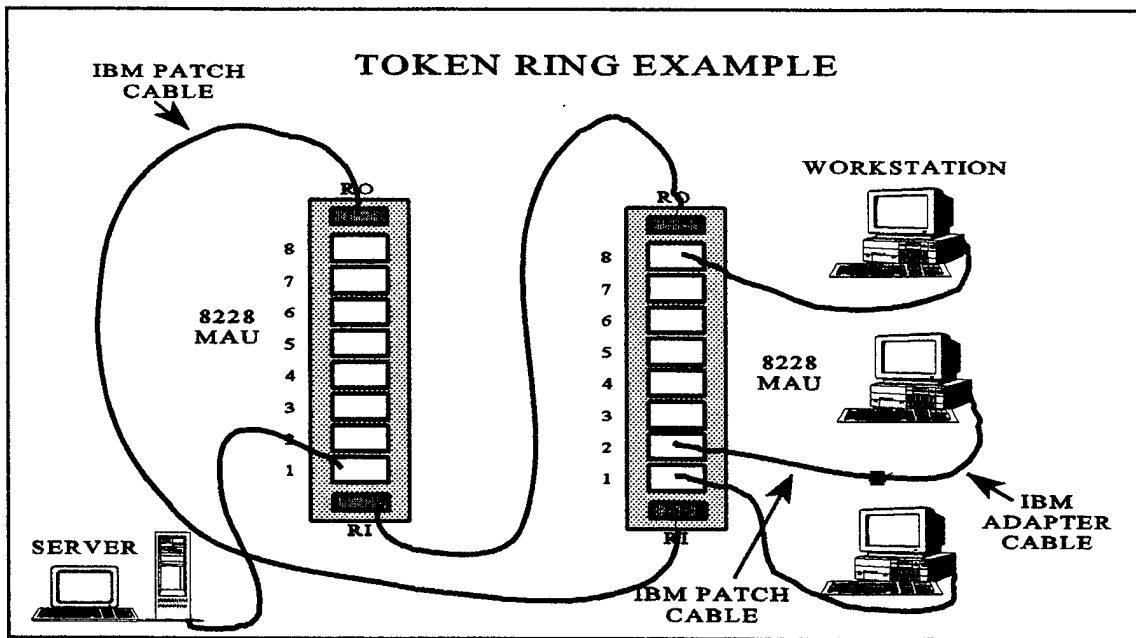

Figure 1. Token Ring Example

1. Topology

All three LANs are 16Mbs Token Ring networks that use a star-wired topology that follows the baseband signaling and token passing protocols of the IEEE 802.5 Standard. [Feibel] provides an excellent description of the IEEE 802.5 Standard.

User computers are connected to IBM 8228 MAUs using IBM shielded twisted-pair (STP) adapter cables and patch cables. MAUs are interconnected with patch cables. Fig 1. illustrates how user computers and MAUs are interconnected.

2. Physical Separation

The physical distance between the lab rooms is a critical factor in determining the method of interconnection. The distance between MAU's in a 16Mbs Token Ring Network is limited to 390 ft. If the distance between the labs is under 390 ft, a straightforward connection can be accomplished with IBM patch cables. If the ring length is over 390 ft, an IBM 8218 Copper Repeater must be attached at each end of the connection.

3. Hardware

With few exceptions, all of the server and user computers are 486DX33 PCS from a variety of vendors. Appendix B provides tables with specifications on all workstations and servers in the Systems Management Department's LANs.

4. Software

Many types of software systems come under the umbrella term "software", including but not limited to the NOS, DOS, Windows, application programs and batch files. Managing the interactions among these different software systems is one of the LAN administrators biggest challenges. For example, all of these programs compete for limited memory resources. If two programs try to use the same area of RAM, *insufficient memory* errors result. The following is installed in the Systems Management Department's LANs;

- NOS: IBM's PCLAN v1.21 and 1.33;
- DOS: MS-DOS v5.0 and MS-DOS v6.0;
- Windows 3.1: I-250 and I-158 only (planned for I-224);
- NETBIOS: IBM's LAN Support Program v1.21, 1.26 and 1.33;
- Applications: A wide variety of Windows and DOS applications are installed in the LANs. The next chapter will provide a more detailed discussion of the application software.

E. HUMAN RESOURCES

A network's reliability and performance is directly influenced by the number of people and man-hours that can be devoted to network maintenance. This network maintenance includes but is not limited to hardware, software, documentation and user assistance.

Increasing user demand for Windows applications has severely strained LAN administration resources. A typical Windows application like WordPerfect can take hours to install on a network. Not only must it be installed on the server, but individual user

computer installations must be performed as well. Installing these applications on three separate networks is motivation for integrating the three LANs in itself.

The three token-ring LANs, and three other small LANs in the same rooms, are supported by one full-time technician. These six LANs contain over 80 PCS, with backbone, mainframe and dialup connections.

F. REQUIREMENTS

Planning for the integration of the SM LANs must include an assessment of two important criteria;

- The present and future needs of the wide variety of users in the Systems Management Curriculum.
- The future changes in the Systems Management Department's network plans.

The goals of SM LAN administration must meet the requirements of the users, while dovetailing with the network plans of the department.

1. User Requirements

The Systems Management Department is the largest department at NPS, with over five hundred students. A wide variety of standard management curriculums (i.e., Transportation, Acquisition, Financial and Manpower) are offered, in addition to an Information Technology Management (ITM) curriculum.

Both the ITM and other Management curriculums have a requirement for LAN labs that offer standard Windows and DOS based office automation applications and curriculum specific software packages. However, the ITM curriculum requires the LANs also provide a variety of different LAN topologies and architectures for networks research and hands-on familiarization.

2. SM Department Network Plans

To support the variety of curriculums, the SM Departments future network plans include a utility high performance Windows environment lab to support all curriculums,

and improved support for software metrics research and a dedicated networks lab with a variety of topologies and architectures to support the requirements of the ITM curriculum.

While the different topologies and architectures exist in the three LANS, student hands-on training requires significantly more support personnel than is currently available, thus the emphasis has been placed on LAN utility, but with a degree of hands-on training in the ITM curriculum.

3. SM LAN Administration Goals

SM LAN Administration integration goals are driven by user needs, Department requirements, and LAN support personnel constraints. User demands for Windows application programs severely tasks the single support person. Integrating the three independent Token Ring LANs with their similar software applications would seem a logical step in decreasing staff workload. Overall, the SM LAN Administration goals, given their present constraints are summarized below:

- Decrease staff workload through integration of all three labs onto single set of file servers.
- Provide users access through a common Windows GUI to all network assets regardless of physical location within the three labs.
- Increase network performance and reliability.

G. CHAPTER SUMMARY

This chapter reviewed terms and concepts used throughout subsequent chapters, and provided background on the history, evolution, state of the LANs as they existed prior to the integration. It also looked at the requirements of the users, the SM Department, and the goals of the LAN Administration. The following chapters will detail the integration design, planning and implementation.

III. INTEGRATION PLANNING

This chapter discusses the different aspects of the design and planning involved in the integration of the SM LANs.

A. APPLICATION SOFTWARE ASSESSMENT

A starting point for an analysis of the needs of the integrated network is to do a complete inventory of the application software in the three LANs. Once an inventory is completed, a comparison of the inventory of each LANs will reveal which applications are duplicated. In addition, each application can be assessed against user requirements, and a decision made to migrate the application to the integrated network as is, upgrade the application, or discontinue the application.

Once the final list of applications is approved, storage requirements can be assessed and a software directory mapping plan formulated. The following subsections detail the software applications installed on the LANs.

1. Software Location

Within each LAN, application software is installed in one of three locations:

- On a server in a read only directory (APPS) is the normal and preferred method of installation.
- On a server in an unprotected directory (USER) is used for applications that require write capability to certain files and for applications that individual students or professors need to install on a temporary basis.
- On either the *C:* or *D:* partition of each individual user computer hard drive. This location is used for applications that are not network compatible and for individual user installations on a temporary basis. Programs that are not network compatible must be migrated to all user computers to get uniform access in the integrated network.

Table 1 summarizes the applications installed in the LANs, their location, size and whether they will be migrated to the integrated LAN.

| Application | Description | Size (Mb) | 0TR | 4TR | 8TR | Migrate |
|------------------------------|-------------------|--------------|------|------|------|---------|
| ACOL (DOS) | Pers Mgmt | 0.50 | y | n | n | y |
| AFAM (Windows) | Pers Mgmt | 1.80 | y | y | n | y |
| AFAMSUP (DOS) | Pers Mgmt | 12.50 | y | y | n | y |
| Criterion (Windows) | Decision Support | 0.70 | y | n | n | y |
| Crystal Ball (Windows) | Decision Support | 10.50 | y | n | n | y |
| Data (Windows) | Decision Support | 1.40 | y | n | n | y |
| Freelance Graphics (Windows) | Graphics | 15.20 | y | n | n | y |
| Logical Decisions (Windows) | Decision Support | 1.80 | y | n | n | y |
| Lotus 123 v4 (Windows) | Spreadsheet | 9.90 | y | n | n | n |
| Lotus 123 v5 (Windows) | Spreadsheet | 25.00 | y | n | n | y |
| Minitab (Windows) | Statistics | 17.60 | y | n | n | y |
| Paradox v3.5 (DOS) | Database | 5.80 | n | y | n | n |
| Paradox v4.5 (Windows) | Database | 15.70 | y | n | n | n |
| Paradox v5.0 (Windows) | Database | 18.00 | y | n | n | y |
| SIMPC v6.0 (DOS) | Dial-up Comms | 1.00 | y | y | n | y |
| Smerfs (DOS) | Reliability Model | 0.60 | y | y | y | y |
| Statgraphics (DOS) | Statistics | 10.40 | user | user | user | user |
| Storyboard (DOS) | Drawing | 1.30 | y | y | n | n |
| TCP/IP (DOS) | Internet Comms | 4.40 | y | y | y | y |
| WordPerfect v5.1 (DOS) | Word Processing | 3.70 | y | y | y | y |
| WordPerfect v6.0 (DOS) | Word Processing | 18.40 | y | n | n | n |
| WordPerfect v6.0a (Windows) | Word Processing | 24.20 | y | n | n | n |
| WordPerfect v6.1 (Windows) | Word Porcessing | 27.00 | y | n | n | y |

Table 1. Installed Software.

2. Hard Disk Storage Requirements

Once the application programs to be migrated have been finalized, an accurate assessment of the minimum hard disk storage requirements can be established. At present, the minimum total storage requirements of the application programs, DOS and NOS is approximately 250Mb. To compensate for expected future growth in Windows applications, a future NOS upgrade, and some built in redundancy for reliability, a total storage capacity of 2Gb for the integrated network is recommended.

B. HARDWARE ASSESSMENT

As detailed in Appendix B, the present servers in the SM LANs are primarily 486DX33 computers with 8MB of RAM and a 200Mb hard disk. While these machines have proven more than adequate for DOS based application programs, some Windows applications perform marginally. In addition, the large size of Windows applications has rapidly outgrown the 200Mb hard drives of the server computers.

The following subsections detail the planning for improving and integrating the hardware for the SM LANs.

1. Pentium Servers

Three IBM Model 950 computers were procured to replace the existing file servers N3 and TN3 in 0TR and 4TR. These computers (designated PN3, PN6 and PN9) are 90Mhz Pentium based machines with 8Mb RAM and a 540Mb hard disk installed. An additional 32Mb of RAM, a 540Mb hard disk and an IBM 16/4 Adapter II Token Ring NIC were procured for each computer as well.

The second hard disks on PN3 and PN6 will provide increased reliability to the network through duplication of the application programs on PN3 C: drive onto PN6 D: drive, and the application programs on PN6 C: drive onto PN3 D: drive. A more detailed discussion of how this is accomplished is presented later in this chapter.

PN9 will be used for a planned Windows NT Server v3.51 installation. The use of this server is not covered in this thesis.

2. Print Servers

Existing file servers TN6M, N6 and TN4 will continue as print servers for each lab. The N6 200Mb hard disk will also serve as the integrated LAN K: drive. TN6M and N6 will also serve as alternate print servers in the event that any one of the three fail.

C. DRIVE MAPPING

In order to understand the drive mapping scheme between the user computers and servers, it is necessary to understand the concept of, and difference between *physical*, *logical* and *virtual* drives as they relate to PCs. These drives are storage locations and are defined as follows;

- Physical - floppy disk drives, hard disk drives, tape drives or CD ROM drives.
- Logical - hard disk partitions, (i.e., a physical 200Mb hard drive partitioned into two 100Mb logical drives) or directories or volumes on the network physical drives that are shared as logical network drives from the user computers perspective.
- Virtual - RAM disks or virtual disks. These use physical resources to mimic physical drives, but their contents disappear when the computer is turned off.

In DOS, drives are referred to by letters. On a PC, A: and B: commonly refer to the floppy disk drives, C: through E: commonly refer to other local drives on the user computer. F: through Z: are logical network drives.

Drive mapping is the process of assigning a hard disk volume or directory to a logical disk drive. For example, the APPS directory (and all its subdirectories) on the C: volume of N3 is assigned the logical drive I: from the user computers perspective as shown in Figure 2. This assignment is performed when the START.BAT files of the user computers are executed. These files will be discussed in more detail later in this chapter.

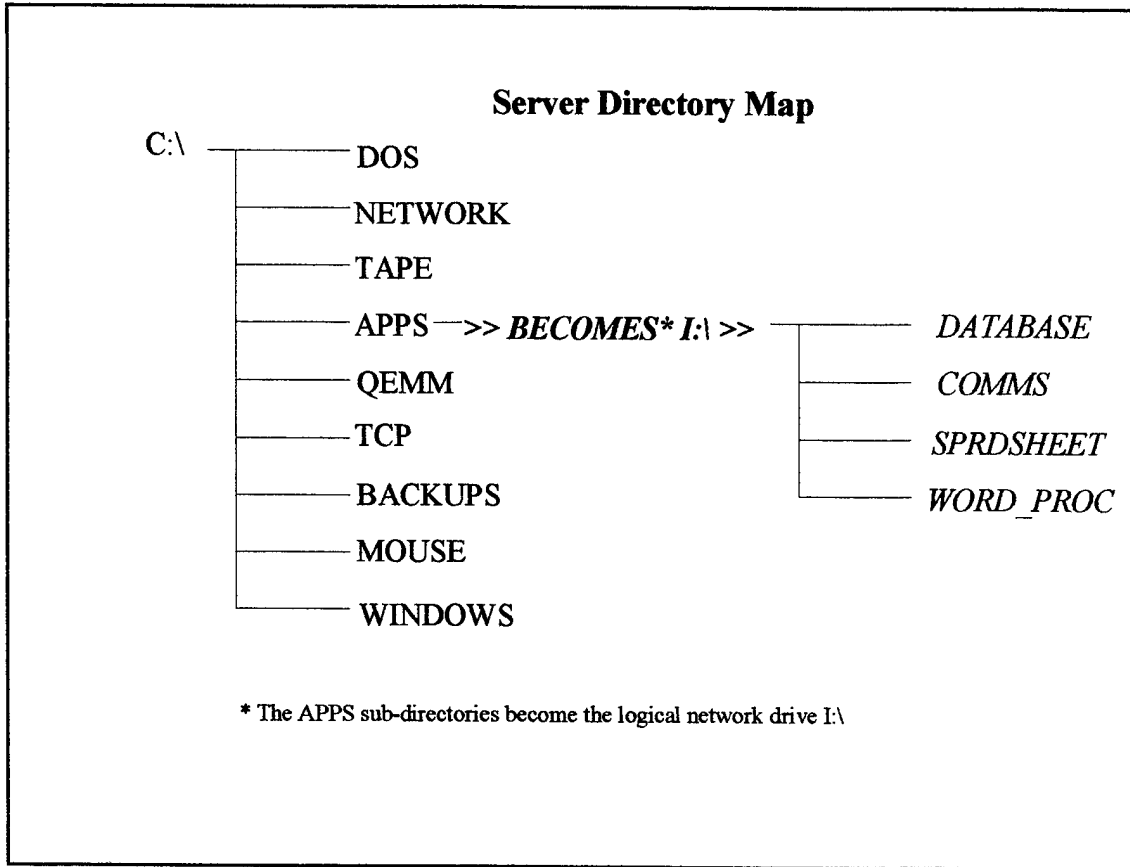

Figure 2. Network Logical Drive

1. Software Migration Strategy

Rather than load all the system software and application software directly onto the new servers from diskette, it was determined that it might be faster and more efficient to connect the new servers to the network, and then download the required files directly from the old servers. Also, over time computer hard disks become cluttered with directories and files of unknown origin created by the users. The SM LANs are no exception, and the integration provides an excellent opportunity to assess the directories and files of the existing servers.

2. Directory Tree Pruning

Using the DOS TREE command, directory maps were made of the existing servers in all three labs. A copy of these directory maps is provided in Appendix C.

In order to build directory maps for the new servers, it was decided to first “prune” away any directories on the existing server maps that fell into any of the following categories;

- All excess directories (i.e., a WP51 directory for WordPerfect 5.1) was in all three labs.
- All directories for software that would not be considered for migration, (i.e., Paradox v3.5, 4.5 and 5.0) were all installed on at least one network, but only 5.0 would be migrated.
- All directories that could not be matched up to software currently being used in any of the labs, (i.e., old backups of user computers, software no longer used etc.).

Once these excess directories were pruned away, directory maps for the new servers could be developed from those directories that were left.

3. Integrated Network Directory Maps

The existing servers in the three labs were all set up in a similar fashion with the network application software files residing in the APPS directory of the servers. Similarly, these APPS directories were used as network drives I:\ and J:\ in both 0TR and 4TR. For example, a user computer in 0TR would access WordPerfect 5.1 (WP51) from network drive I:\ on server N3, while a user computer in 4TR would access WP51 from a network drive I:\ on server TN3. The application software batch file that contained the path and instructions to start WP51 in 0TR was identical to the same file in 4TR.

In order to avoid rewriting application software batch files, it was decided to keep a similar directory/drive structure in the integrated LAN. PN3 APPS directory would be used as I:/ , and PN6 APPS directory would be used as J:/. All application software that resided in an I:/ network drive in the old LANs, would be migrated to an I:/ network drive on the integrated LANs. A copy of the directory maps for PN3 and PN6 is provided in Appendix D.

D. SYSTEM FILE REVISION

While the physical connection of the LAN's is done with hardware, i.e., cable and MAUs, the logical connection is done with software. Software files in both the server and user computers set the environment of the network, direct the sharing and using of network resources, and manage the server and user computers precious memory resources.

This section will provide a discussion of the importance of memory management in a network environment, and how network resources and memory are controlled by the following three files:

- CONFIG.SYS
- AUOTEXEC.BAT
- START.BAT

1. Memory Management

In a DOS environment, one of the most important system resources is memory. Memory affects which programs you can run, how fast these programs will run and how many programs can run concurrently.

While an entire thesis could be written on memory management alone, it is not the topic of this thesis, so I will limit the discussion to four types of memory, and how and why, we need to manage them effectively in a network environment. [Goodman] provides an exhaustive discussion of memory management for further reading.

Management of the following types of memory are critical to efficient operation in a network environment:

- Conventional - conventional memory is the first 640K of RAM on DOS based computers. DOS, NOS, some device drivers and many commands listed in the CONFIG.SYS and AUTOEXEC.BAT files all use some conventional memory. What is left over is available for other application programs. Freeing up the maximum amount of conventional memory possible is the primary goal of memory management.

- Upper- The 384K immediately adjacent to the 640K of conventional memory is called upper-memory. This area of memory is normally reserved for system hardware, such as the monitor or NIC. Through use of a memory manager program, blocks of upper memory (UMBs) can be used by DOS, device drivers and other programs that would normally use conventional memory. This frees up conventional memory for application and NOS software.
- Extended- One definition of extended memory is all memory above 640K (including upper memory), up to whatever amount is physically installed. For example, the user computers in the SM LANs have 8Mb of RAM, which includes 640K of conventional and 7384K of extended (384K upper). Some authors define extended as that memory above 1Mb. Additionally, the first 64K above 1Mb can be used to store DOS buffers. This area is called the High Memory Area. Use of extended memory also requires a memory manager program.
- Expanded- The memory manager, in conjunction with applications that are written to take advantage of expanded memory, pages segments of programs and files from extended memory into a page frame in upper memory. These programs and files that would normally be paged from disk, can be accessed much faster from memory.

While freeing up conventional memory is desirable for the stand-alone DOS computer, it is mandatory for network servers and user computers. The DOS and NOS programs, combined with the LAN Support Program device drivers will consume conventional memory to the point where there is no room for application programs. Therefore it is crucial that these programs be moved to upper memory if possible. This is accomplished through use of an extended memory manager, and commands in the CONFIG.SYS and AUTOEXEC.BAT files.

2. CONFIG.SYS (Server)

The CONFIG.SYS file is located in the root directory of the computer and is the first file looked at by DOS during the computer boot-up. This file contains information about various types of configuration and driver settings. For example, it includes information about drivers and memory managers, and how and where they are loaded into memory. Figure 3 contains the CONFIG.SYS file for PN3. Comments that normally

```

rem  SERVER PN3 CONFIG.SYS FOR INTEG TOKEN RING NETWORK
rem  VERSION: 1.0 dtd 21 Jun 1995

DEVICE=C:\QEMM\QEMM386.SYS RAM ARAM=D800-DBFF AROM=CC00-CDFE
DOS=HIGH
DEVICE=C:\QEMMLOADHI.SYS /H C:\NETWORK\DXMA0MOD.SYS 001
DEVICE=C:\QEMMLOADHI.SYS /H C:\NETWORK\DXMC0MOD.SYS
DEVICE=C:\QEMMLOADHI.SYS /H C:\NETWORK\DXMT0MOD.SYS ST=57 S=63 C=19 ES=1
DEVICE=C:\QEMMLOADHI.SYS /H C:\MOUSE\MMOUSE.SYS
DEVICE=C:\QEMMLOADHI.SYS /H C:\DOS\SETVER.EXE
DEVICE=C:\QEMMLOADHI.SYS /H C:\DOS\RAMDRIVE.SYS 512/E
DEVICE=C:\QEMMLOADHI.SYS /H C:\DOS\RAMDRIVE.SYS 196/E
DEVICE=C:\DOS\SMARTDRV.EXE 6144
LASTDRIVE=G
BUFFERS=20
FILES=255
FCBS=1

```

Figure 3. CONFIG.SYS file for PN3

describe parts of the program have been omitted in Figures 3-7 to ensure the program fits on one page. Appendix E contains the updated system files (with comments) for the server and user computers of the integrated network.

Figure 3 sections in *bold italics* signify changes that were made to the previous servers CONFIG.SYS file to facilitate the integration. A discussion of these changes will be provided at the end of this subsection.

Many of the commands in the CONFIG.SYS file in Figure 3 are fairly common, and detailed descriptions of them can be found in [Microsoft]. However, a brief description of the commands in Figure 3 that are unique to this particular network is provided:

- **DEVICE=C:\QEMM\QEMM.386.....**: This command loads the memory manager program. The AROM and ARAM switches designate memory addresses in upper memory that are reserved for the NIC. The memory manager will then avoid loading any programs into those addresses.
- **DOS=HIGH**: Loads DOS in the High Memory Area.
- **DEVICE=C:\QEMMLOADHI.SYS/H...NETWORK...**: Loads the network LAN Support Program device drivers into upper memory. ST, S and C define maximum station, session parameters and command parameters in the network. The ES parameter allows the TCP/IP protocols to operate compatibly with the NOS. [IBM] provides a more detailed description of these parameters.

- **DEVICE=C:\QEMMLOADHI.SYS/H...RAMDRIVE....**: These commands create a 512K and a 196K RAM drive in extended memory. NOS files and application software batch files will be copied into these RAM drives during execution of the AUTOEXEC.BAT file. Storing these files in a RAM drive decreases the time it takes to access them thus improving network performance.

a. File Modifications

The changes to the CONFIG.SYS file for the server computers in the integrated network were relatively minor. Due to the increase in the number of user computers that a server would communicate with in the integrated network, the following parameters in the LAN Support Program drivers had to be increased:

- **STATIONS (ST)** - Indicates the maximum number of NETBIOS interface link stations that you may define, i.e., maximum number of user computers that can use this server
- **SESSIONS (S)** - Indicates the maximum number of NETBIOS sessions that you may define, i.e., maximum number of active sessions of user computers with server
- **COMMANDS (C)** - Indicates the maximum number of NETBIOS interface commands that may be outstanding at one time.

3. CONFIG.SYS (User Computer)

There are very minor differences between the CONFIG.SYS file in the servers and user computers. For example, the user computers do not have RAM drives, but they might have a CD-ROM reader; therefore, some of the device driver commands will be different. The LAN Support Program driver parameters are also smaller due to the user computer interfacing with only a few servers, vice a server interfacing with all the user computers.

Figure 4 is the CONFIG.SYS file for a typical user computer (TN5). No changes to the user computer CONFIG.SYS files were required for the integration.

```

rem  USER (TN32) CONFIG.SYS FOR INTEGRATED TOKEN-RING NETWORK
rem  VERSION: 1.0 dtd 21 Jun 1995

SHELL=C:\COMMAND.COM/P/E:512
DEVICE=C:\QEMM\QEMM386.SYS RAM ARAM=D800-DBFF AROM=CC00-CDFF
DOS=HIGH
DEVICE=C:\QEMMLOADHI.SYS /H C:\NETWORK\DXMA0MOD.SYS 001
DEVICE=C:\QEMMLOADHI.SYS /H C:\NETWORK\DXMC0MOD.SYS
rem  21 Jun 1995, pjm. DXMT0MOD.SYS parameters derived as follows;
rem  ST=max NETBIOS interface links for user computer = # of Servers+1 =6
rem  S=SES setting in NET START command in start.bat = 25
rem  C=CMD setting in NET START command in start.bat = 8
rem  ES=additional SAPs requested by NETBIOS driver when it opens adapter = 1
DEVICE=C:\QEMMLOADHI.SYS /H C:\NETWORK\DXMT0MOD.SYS ST=6 S=25 C=8 ES=1
DEVICE=C:\QEMMLOADHI.SYS /H C:\MOUSE\MMOUSE.SYS
DEVICE=C:\QEMMLOADHI.SYS /H C:\APPS\DOS\SETVER.EXE
DEVICE=C:\QEMMLOADHI.SYS /H C:\APPS\DOS\ANSI.SYS
LASTDRIVE=E
BUFFERS=20
FILES=30
FCBS=1

```

Figure 4. CONFIG.SYS for User Computer TN32

4. AUTOEXEC.BAT (Server)

The AUTOEXEC.BAT file is the final step in the booting process of a Server PC. It provides the final chance to customize the working environment of the PC for the session automatically. For example, it may load device drivers, set the command line prompt, set environmental variables and load the network operating system. For a server computer, the AUTOEXEC.BAT is where the commands to share its resources with the network are located.

Figure 5 contains the AUTOEXEC.BAT file for the Pentium server PN3. Many of the commands in this file are fairly common, and detailed discussions of them can be found in [Goodman]. Commands in *bold italics* are modifications that will be discussed at the end of the subsection. A brief description of some of the commands in Figure 5 is provided below:

```

::***SERVER PN3 AUTOEXEC.BAT FOR SM TOKEN RING NETWORK
:: VERSION 1.0 dtd 21 Jun 1995

PATH E:\C:\DOS;C:\QEMM;C:\C:\BAT;C:\NETWORK;C:\PCTCP;D:\D:\DOS
LOADHI /H FCBS=8
LOADHI /H C:\DOS\FASTOPEN.EXE C:=-200/X
SET TEMP=C:\TEMP
SET DIRCMD=/O/P
LOADHI /H C:\DOS\DOSKEY
LOADHI /H C:\NETWORK\SHARE.EXE

XCOPY C:\NETWORK\*. * E:
ATTRIB +R E:\*. *
LABEL E:NETFILES
XCOPY C:\DIRPLUS\DIRPLUS.EXE F:
XCOPY C:\BAT\*.BAT F:
ATTRIB +R F:\*. *
LABEL F:BATCHDIR

NET START SRV PN3 /SHR:15 /RQB:16K /PRB:16K /RDR:57 /CMD:19 /SES:63 /REQ:3 /TSI:00
NET SHARE APPS=C:\APPS /R
NET SHARE BATFILES=F: /RW
NET SHARE LOTSHARE=C:\LICENSES.DIR\LOTSHARE /RWC
NET SHARE APPS1=D:\APPS /R

C:
PROMPT $PSG
SET PCTCP=C:\PCTCP\PCTCP.INI
IBMTR

```

Figure 5. AUTOEXEC.BAT file for PN3

- The first block of commands are fairly common commands that set the path for the computer, load more drivers and commands into upper memory and set the environment parameters.
- In the second block the XCOPY command copies files from the C:\NETWORK and BAT directories to the RAM drives E: and F:. The ATTRIB +R command sets the files in the RAM drives as read only. The LABEL command assigns the labels NETFILES and BATCHDIR to the RAM drives.
- In the third block, the NET START command starts PN3 as a server on the network. [IBM] provides a more detailed explanation of the parameters in this command. The NET SHARE commands allow the network to share different directories of server PN3. For example, NET SHARE APPS=C:\APPS/R shares directory "APPS" (and its subdirectories) as read only.
- In the fourth block, the path is set to the root directory, the DOS prompt is reset and TCP/IP software is started.

a. File Modifications

There were two modifications to the server AUTOEXEC.BAT files. The parameters RDR, SES and CMD of the NET START command were increased to match the S, ST and C parameters in the server CONFIG.SYS files LAN Support Program driver parameters. NET SHARE APPS1=D:\APPS/R was added. This provides a backup for the "APPS" directory of PN6 in the event PN6 fails.

5. AUTOEXEC.BAT (User Computer)

The AUTOEXEC.BAT file for the user computers in the network is primarily used to provide environment settings and load additional drivers and files into upper memory. Only minor changes were required to this file for the integration. They are described at the end of this subsection. Figure 6 contains the AUTOEXEC.BAT file for a typical user computer. A brief description of the commands is provided below;

- The SET command in the first group of commands is setting the environment variables. These variables control the behavior of batch files and programs in the DOS environment. For example, the SET MODEM=N and SET EMULATION=N tell DOS that there is no modem or 3270 emulation board

```

:: AUTOEXEC.BAT (TN32) FOR OTR TOKEN RING NETWORK
:: VERSION: 1.0 dtd 21 Jun 1995

cls
@ECHO OFF
SET 1DIRPLUS=C:\1DIRPLUS
SET MONITOR=VGA
SET MATH=Y
SET MODEM=N
SET EMULATION=N
SET PR TSRVR=TN6M
SET ALTPR TSRVR=N6
SET P=C:\NETWORK;C:\WINDOWS;C:\APPS\DOS;C:\;C:\1DIRPLUS;C:\PCTCP;C:\QEMM
PATH %P%
LOADHI /H C:\APPS\DOS\FASTOPEN.EXE C:=50 /X
LOADHI /H FILES+20
LOADHI /H FCBS=8
LOADHI /H LASTDRIV=M
LOADHI /H C:\WINDOWS\SMARTDRV.EXE
SET COMSPEC=C:\COMMAND.COM
PROMPT $P$G
VSHIELD /M /CHKHI /LOCK /CONTACT "CONTACT THE LAB STAFF OR THE DEPARTMENT SECRETARY" /SWAP
NEWUSER
SHARE
```

Figure 6. AUTOEXEC.BAT for User Computer TN32

installed in this computer. This allows batch files to test these settings prior to looking for a modem or 3270 board, and generate an error message if the test indicates that none are installed.

- The remaining commands load various drivers and programs into high memory and installs antivirus software. The SHARE command loads code that supports file-sharing and locking in a network environment.
- NEWUSER displays a message to the user with instructions on starting and using the SM LAN.

a. File Modifications

To facilitate the use of a backup print server, the SET ALTPRTSRVR command was added to all user computer AUTOEXEC.BAT files. How this is accomplished will be covered in more detail in the next section.

6. START.BAT

The START.BAT file is an important member of the network batch files. This file provides a customized start-up procedure for the user computers onto the network. It is initiated by typing the command "Start", followed by a variable, for example, "Start TN6" or "Start Norm".

This file contains commands that direct the use of network resources such as server directories and printers. This file also provides for system redundancy within the network, through use of "branch on error" routines available in the DOS batch file language.

Figure 7 contains the START.BAT file for a typical user computer on the integrated network. All user computer START.BAT files are alike. Any variations between computers, such as, computers in different labs using different print servers, are taken care of when the environment variables are set by the AUTOEXEC.BAT file.

```

:: 4TR USER START.BAT FOR SM INTEGRATED NETWORK
:: VERSION: 1.0 dtd 21 JUN 1995

@ECHO OFF
CLS
STRMSG

NET START RDR %1 /SRV:5 /ASG:7 /PB1:15K /PB2:1K /CMD:8 /SES:25
IF ERRORLEVEL 1 GOTO NOTICE
NET USE I: \PN3\APPS
IF ERRORLEVEL 1 GOTO PN3_FAIL
NET USE F: \PN3\BATFILES
NET USE J: \PN6\APPS
IF ERRORLEVEL 1 GOTO PN6_FAIL
GOTO PRINTER_SETUP

:PN3_FAIL
SRVFAIL
PAUSE
NET USE F: \PN6\BATFILES
IF ERRORLEVEL 1 GOTO BOTH_FAIL
NET USE I: \PN6\APPS1
GOTO PRINTER_SETUP

:PN6_FAIL
SRVFAIL
PAUSE
NET USE J: \PN3\APPS1
GOTO PRINTER_SETUP

:BOTH_FAIL
NETFAIL
PAUSE
GOTO EXIT

:PRINTER_SETUP
NET USE LPT1 \\%PRTSRVR%\PRINT
NET USE K: \\ALTPRTSRVR%\USER
IF ERRORLEVEL 1 GOTO PRINT_FAIL
GOTO END

:PRINT_FAIL
ECHO THE PRINT SERVER HAS FAILED, "NOTIFY LAB STAFF". IF YOU ELECT TO PRINT
ECHO YOUR PRINT JOBS WILL BE PRINTED IN THE OTHER SM LAB. (250 OR 224)
PAUSE
NET USE LPT1 \\ALTPRTSRVR%\PRINT
IF ERRORLEVEL 1 GOTO PRN_FAIL2
GOTO END

:PRN_FAIL2
ECHO BOTH PRINT SERVERS HAVE FAILED, "NOTIFY LAB STAFF"
PAUSE
GOTO END

:NOTICE
USERFAIL
PAUSE
GOTO EXIT
:END
SET PCTCP=C:\PCTCP\PCTCP.INI
IBMTR
f

:EXIT
1DIRPLUS

```

Figure 7. START.BAT file for user computer

An explanation of some of the representative commands and logic in the START.BAT file is provided below:

- **NET START RDR %1** - Starts the computer on the network as a user computer or redirector (RDR), of variable %1. %1 is a placeholder that will assume the value of whatever was typed in after 'START', i.e., TN5 or NORM.
- **IF ERRORLEVEL 1 GOTO** - A branch on error command. If the preceding command in the file does not execute correctly for whatever reason, DOS will set an error flag. If DOS tests the flag and it is 1, the batch file will jump or 'GOTO' a line in the file that matches the word after GOTO. For example, if the NET START command does not execute successfully, the program will jump to the line that starts with the word NOTICE near the bottom of the file, display a message from an executable file called USERFAIL, PAUSE and then GOTO EXIT, which then executes the DOS utility program 1DIRPLUS.
- **NET USE I: \\PN3\APPS** - Assigns virtual drive I: (from user computers perspective) to the APPS directory (and all its subdirectories) of server PN3.
- **NET USE LPT1 \\%PRTSRVR%\PRINT** - Assigns user computer LPT1 to network printer PRINT, on server that was set by the SET PRTSRVR= command in the user computer AUTOEXEC.BAT.

The rest of the batch file is made up of similar commands that NET USE various network resources, test for error levels, continue to the next command if there is no error present, or branch to a set of commands that will assign backup drives or printers to the user if an error is detected.

It must be made clear that these backup devices will not come on line automatically during normal user operation. If a server fails at some point after the user has started on the network, the user must reboot the computer, and log on. This will allow the START.BAT file to find the error and redirect the flow of the program to the backup devices.

a. File Modifications

This file was completely modified from its original version. There was no redundancy built in to the previous networks. The only command tested with a branch on error routine was the NET START command. A copy of the previous START.BAT file is provided in Appendix E.

E. PHYSICAL CONNECTION

All three SM LAN labs are located in Ingersoll Hall on the NPS campus. 0TR and 4TR are located at opposite ends of the 2nd floor in rooms 250 and 224 respectively. 8TR is located approximately between 0TR and 8TR one floor below, in room 158. The distance between any two labs is less than the 390 ft constraint described in the previous chapter, therefore a straight forward connection with IBM patch cables was deemed feasible. A building map with the proposed route of the interconnecting cable runs is provided in Appendix F.

F. TESTING

One cannot over emphasize the importance of testing "in the small" prior to implementation "in the large", especially if the changes are to be implemented into a working environment like the SM LANs. All hardware, software and media must be tested thoroughly prior to implementing any changeover strategies.

1. 8TR Test-bed

The 8TR network in I-158 would provide a test-bed "in the small" for the integrated network. A simple design/test plan was conceived along the following lines:

1. Complete the physical connection of the three LANs. This would be accomplished by either public works or by LAN staff.
2. Assess the application software and perform the directory pruning
3. Once server hardware arrived, install hard drives, RAM and NIC's. Connect PN3 and PN6 into two open slots in the MAU in 8TR.

4. Install NOS, LAN Support Program drivers, modified CONFIG.SYS and AUTOEXEC.BAT on PN3 and PN6. Ensure the servers are connected logically to the network and can be brought up on the network as servers. Tune the CONFIG.SYS and AUTOEXEC.BAT files to ensure use of conventional memory is minimized.
5. Download the application software and application software batch files from the existing servers onto PN3 and PN6. Modify application software batch files if required, to ensure the new paths are correct.
6. Set up two user computers in 8TR with the modified user computer CONFIG.SYS, AUTOEXEC.BAT and START.BAT files. Tune CONFIG.SYS and AUTOEXEC.BAT files to ensure use of conventional memory is minimized.
7. Boot up two user computers in 8TR from Pentium servers. Test branch on error conditions in START.BAT files to ensure system redundancy capabilities are working.
8. Install Windows 3.1 and any 'workstation' copies of Windows applications on the two user computers in 8TR. Ensure all Windows application icons and their paths are correct.
9. Test all application software, both Windows and DOS, on each of the two user computers separately, and then concurrently.

Once satisfied that all software is functioning correctly in the test bed, the modified CONFIG.SYS, AUTOEXEC.BAT and START.BAT (the three critical files) can be installed (on a temporary basis) on the remaining user computers in the three LANs and testing "in the large" can begin.

2. Integrated LAN Testing

Testing of the entire integrated LAN must be accomplished while the LANs are expected to conduct business as usual. Therefore it is imperative to minimize disruptions and possible problems. Any changes made to the existing LAN for testing must be able to be reversed when the test is completed.

The following plan was designed to test the integration plan "in the large";

1. Install the three critical files in each user computer. Use a different file extension so the existing files are not overwritten. Modify the new files as required to conform to each individual user computers peripheral devices, i.e., modems, printer, etc.
2. To test each user computer on the integrated network, the critical files must be temporarily replaced by the new modified files. When the test is completed, the old system files must be restored. The new files are renamed permanently, once the integrated network becomes fully operational. This can be accomplished easily with the two batch files in Figure 8. These two batch files would be installed in the root directory of each user computer

```
PENTIUM.BAT  
  
RENAME CONFIG.SYS CONFIG.33  
RENAME AUTOEXEC.BAT AUTOEXEC.33  
RENAME START.BAT START.33  
  
RENAME CONFIG.PEN CONFIG.SYS  
RENAME AUTOEXEC.PEN AUTOEXEC.BAT  
RENAME START.PEN START.BAT  
  
DX33.BAT  
  
RENAME CONFIG.SYS CONFIG.PEN  
RENAME AUTOEXEC.BAT AUTOEXEC.PEN  
RENAME START.BAT START.PEN  
  
RENAME CONFIG.33 CONFIG.SYS  
RENAME AUTOEXEC.33 AUTOEXEC.BAT  
RENAME START.33 START.BAT
```

Figure 8. RENAME Batch Files

3. To test a user computer on the integrated network, type "Pentium" at the C:\ prompt. Once the file has successfully executed, reset the computer and log on normally. The test plan that was used on the test-bed user computers in I-158 can now be used on each user computer (This will include installing Windows 3.1 on all computers in I-224). Once any testing is completed, path back to C:\ and type "DX33". This will restore the original system files and the computer will boot from its normal location when rebooted.
4. Once each user computer has been individually tested successfully on the integrated network, each LAN, and then all three LANS can be tested.

5. Once successful testing of all three LANs on the new servers is completed, N3 and TN3 can be removed from the network, and PN3 and PN6 can be installed in their place.

Once the transition is complete and the integrated network becomes the normal mode of operation, the LAN administrator must observe everything carefully and talk to users to get as much information as possible about bugs in the system, inefficiency and user problems.

G. CHAPTER SUMMARY

This chapter described the methodology of the design, planning and testing of the integrated SM LANs. As of this writing, a majority of the work is complete and the effort is ongoing. The final chapter discusses the results of the integration effort as it stands today, problems encountered, and recommendations for further improvements to the SM LANs.

IV. RESULTS, CONCLUSIONS AND RECOMMENDATIONS

This chapter discusses the implementation of the integration plan put forward in the previous chapter. Although the integration is not fully complete, the primary elements of the effort, the physical and logical connections, have been implemented and tested successfully.

Before discussing the results of the overall integration effort, it is important to refocus on the two primary objectives of this thesis, the physical and logical connection of the three SM LANs. The tasks required to complete the two primary objectives are summarized:

- **Physical Connection** - Install the necessary cabling (and repeaters if required) to make the physical connection between all three token-ring SM LANs.
- **Logical Connection** - Centralize all application software on common servers and rewrite server and user computer batch files to allow universal access to all network resources, regardless of location.

The following sections discuss the results and some of the problems encountered during the different phases of the implementation. Conclusions and recommendations for further improvements to the LANs are provided.

A. RESULTS

The results of the integration are summarized in the following subsections. The summarizations discuss results of the primary objectives; the physical and logical connection of the LANs, and the secondary objectives; the installation of new server hardware and upgrading and standardization of application software.

1. Physical Connection

Installation of the cabling between the three LANS went smoothly. In 1994, two connections between 4TR and 0TR were installed by the LAN administrator using a combination of 150 ft and 75 ft patch cables. A site survey conducted by the LAN

administrator and the author determined that 8TR could be included in the integrated LAN without the use of repeaters. One cable connection between 0TR and 4TR was opened and 150 ft patch cable were connected to each end. The two patch cables were then run through a cable way in I-282, to the computer room in I-135. From there the cables were run to I-158 and connected to the ring-in and ring-out ports in the MAU in 8TR. The LAN administrator and the author installed the cabling in approximately eight hours, over two afternoons. A map of the cable run is provided in Appendix F. A map of the connected LANs is provided in Appendix G.

2. Logical Connection

The logical connection was accomplished by centralizing all application software on servers PN3 and PN6, and modifying the critical system start-up files in the server and all user computers. This part of the integration went smoothly, with a few minor problems:

- The IBM servers came loaded with PC DOS 6.3. When trying to execute some of the network commands, such as NET START or NET SHARE in the server AUTOEXEC.BAT files, the error message *incorrect DOS version* was returned. This is caused by the program file not being in the *DOS version table*, or a mismatch between the *DOS version table*, and the version of DOS that a program file such as NET.COM was designed to run. The *version table* lists names of programs and the DOS version, that (in this case PC DOS 6.3), reports to the specified program file when it's run. In this case, NET.COM 5.00 did not exist in the table. This table can be updated with the SETVER command. [Microsoft] provides a more detailed explanation of the *version table* and use of the SETVER command. In any case, due to the significant time span between the release dates of PCLAN v1.2 NOS and PC DOS 6.3, there were a considerable number of mismatches and missing commands in the version table. Once these were updated, the start-up files ran correctly.
- PN3 and PN6 would not logically connect to the token-ring when initially brought up after they were physically connected to the MAU. This connection occurs when the network drivers of the LAN Support Program are loaded by the CONFIG.SYS file. Further investigation revealed that the new 16/4 Adapter II NICs installed in the servers require LAN Support Program v1.3 or later. Version 1.21 was installed, and a later version was not available,

therefore, the new cards were removed and replaced with spare 16/4 Adapter NICs. This corrected the problem and the servers came up normally.

- The PCLAN NOS v1.2 would not support over twenty-nine stations on a LAN. This had not been a problem as none of the LANs were that large. The integrated LAN required support for at least sixty. This was corrected by upgrading the servers to v1.3 which supports up to 256 stations.
- PN3 and PN6 could not run the TCP/IP program due to insufficient conventional memory. Typically the conventional memory on the servers in SM LANS is almost all used. This is usually not critical because no applications programs are run from the server and once the AUTOEXEC.BAT file has executed, the conventional memory requirements for the session will not change. In this case, extra commands in the revised AUTOEXEC.BAT file took just enough more conventional memory, that the last command executed, (the TCP/IP program) did not have enough conventional memory to load. Because there were no commands that could be eliminated, the only recourse was to try to load additional programs and or drivers into upper memory. At first glance, there were no remaining upper memory blocks (UMBs) large enough to load any of the remaining drivers or programs running in conventional memory. In addition, many programs require more initial memory to load, than they do to run, so programs that look like they might be able to fit into a certain size UMB will not. In cases like these, a memory manager program with a good set of utilities is essential. Using the Quarterdeck memory manager, we were able to observe the memory requirements of all the drivers and programs while they were loading versus while they were running. We then tuned the execution sequence in the CONFIG.SYS and AUTOEXEC.BAT for maximum free conventional memory, and were able to get the TCP/IP program to load. [QUARTERDECK] provides additional information on maximizing conventional memory.

3. Hardware

With the exception of the 16/4 Adapter II NICs not being compatible, which was more of a software problem than hardware, both new servers worked well. Initially, PN6 would not boot up correctly after the additional hard drive was installed, however, this was caused by an incorrect dip switch setting on the hard drive. As of this writing, the additional hard disk for PN3 has not arrived, therefore, the redundancy capability of the servers is not fully available.

One of the reasons for purchasing the Pentium servers was to increase the LAN performance. However, the test-bed results showed no noticeable increase in the network response time for tasks such as booting up on the network or loading a Windows application. This was to be expected because network performance is governed by the weakest component in a network. Currently, this component is the user computer. With the planned upgrade of the 486/33Mhz (8Mb RAM) user to Pentium 90 MHz computers with 16Mb RAM, a noticeable improvement in performance should be observed. Also, the planned installation of faster network boards should help. However, the fact that the drivers for these boards must be loaded into conventional memory detracts from this approach.

4. Application Software

The application software section of the integration has not been completed as of this writing. This part of the process has proven the most time consuming and difficult part of the integration. Although DOS applications were fairly straightforward, Windows applications were another matter, with the following problems encountered:

- Initial errors in loading some Windows applications on the original servers in OTR were not discovered until after these applications had been migrated to the new servers. These applications were downloaded to the new servers using the DOS XCOPY command. This method was considered substantially faster than installing from diskettes, and in fact was. However, the time, saved in loading, has been lost debugging two sets of servers! As of this writing, debugging of the problem Windows applications is ongoing in OTR. As the errors are found, the problems are corrected in both OTR and the test-bed system.
- Windows 3.1 has been installed in 4TR, however, installation of Windows applications (workstation copies) in 4TR has been halted until the problems in OTR are corrected.

B. CONCLUSIONS

When completed, the integration of the SM LANS will provide considerable improvements for both the user and LAN administrator. Centralizing the software on a

single set of servers will reduce the workload of the LAN administrator and provide the user with uniform access to all network resources regardless of location.

Increasing demand from students and faculty for the latest software applications puts tremendous strain on the single support person. The average user looks at software installation from the "standalone paradigm" of his home computer, and does not understand the tremendous amount of time required to successfully install and test an application on a server with sixty user computers. A delicate balance must be struck by the LAN Administrator between appearing nonresponsive to valid user requirements, and installing or allowing the user to install anything at any time.

In the end, the user is the customer and the customer is the reason the LAN exists. Therefore, it is imperative that steps be taken to continue to improve and upgrade both network performance and application software.

C. RECOMMENDATIONS

To obtain the improvements discussed above, this study recommends several areas that specific changes be considered.

1. Hardware

Increasingly complex Windows applications demand more powerful computers to run them. Upgrade and or replace user computers and NIC as follows:

- ! User Computers - At a minimum, upgrade the DX33 user computers to DX4 or Pentium and increase the RAM to 16Mb. Existing monitors are adequate.
- ! NIC - Replace the present 8 bit IBM 16/4 Adapter NICs with 16 bit NIC with onboard DMA processing such as the IBM 16/4 Adapter II. However, the NOS must be upgraded before this can be accomplished.

As of this writing, procurements are in process for the partial replacement of these two items.

In order to determine the most cost effective solution, implement different combinations of the above solutions to determine the solution that provides the most improvement, for the least cost.

2. Software

Software improvements must not be limited to applications and NOS, but an overall department policy concerning software installation should be developed as well. Some recommendations are:

- Upgrade the NOS as soon as possible. This seems to be the only solution to the present printing problem. A modern NOS would probably increase LAN performance, and provide the ITM students with exposure to a NOS that is state-of-the-art and in common use in both DOD and the private sector. Candidates for a new NOS are being evaluated currently.
- Install an office automation suite. Applications in these suites are designed to interface more efficiently together. Many users have suites on their home computers and will expect them on the LAN.
- Get the jump on the inevitable user demand for more advanced windows software by installing it in conjunction with the new NOS.
- The Systems Management Department must set a policy for the installation of application software and stick to it. A student or faculty member's personal preference is not a reason to subject the single LAN administrator to the installation of a new database or spreadsheet program on a sixty computer LAN, when a comparable program is already installed.

3. Personnel

At a minimum, at least two more support personnel for the labs are required: One as an application consultant and the second to support the proposed dedicated network lab in I-224.

Upgrades in hardware and software must be extensively tested before being made available to the users. This testing will require a significant amount of time from the single support person. More support staff will be required to transition the SM LANs to the next plateau, while still providing the day-to-day end user support.

4. Life Cycle Support

The above recommended solutions will provide for significant improvements to the SM LANs. However, they are only “interim” solutions to the problem of keeping up with “exponential” advances in hardware and software. Rather than wait for sporadic funding for the “LAN upgrade” every few years, a philosophy of life cycle, “cradle-to-grave” cost of ownership must be adopted. In other words, a “sustainable” solution must be developed that will provide consistent year-to-year funding, for support personnel, hardware and software upgrades, maintenance and repair, and eventual equipment replacement. Table 2 provides a sample five-year life-cycle support plan for the SM LANs. All dollar amounts are in thousands, a four percent growth rate is included. Description of the line items are provided below:

- Support Personnel: Three people at @75K/yr.
- Software Upgrades: Software upgrades and site licenses for applications programs and NOS.
- Hardware Upgrades: Periodic upgrades of monitors, hard disks, etc.
- Maintenance & Repair: Repair as needed for lab equipment.
- Equipment Replacement: Replacement of workstations and peripherals.

| Line Item | FY96 | FY97 | FY98 | FY99 | FY00 |
|------------------------------|------|------|------|------|------|
| Support Personnel 3 @ 75K/yr | 225 | 234 | 243 | 253 | 263 |
| Software Upgrades | 20 | 21 | 22 | 23 | 24 |
| Hardware Upgrades | 10 | 10 | 11 | 11 | 12 |
| Maintenance & Repair | 5 | 5 | 5 | 6 | 6 |
| Equipment Replacement | 65 | 68 | 71 | 74 | 77 |
| Total | 325 | 338 | 352 | 367 | 382 |

Table 2. Five Year Support Plan.

D. SUMMARY

The integration of the SM LANS is an important technical achievement. It provides location-independent computing, a campus-wide computing policy, and reduces costs through consolidation of network resources. Initiatives have been undertaken to transistion the networks to a modern NOS.

APPENDIX A. LAN DIAGRAMS

I-250 Token Ring LAN (0TR)

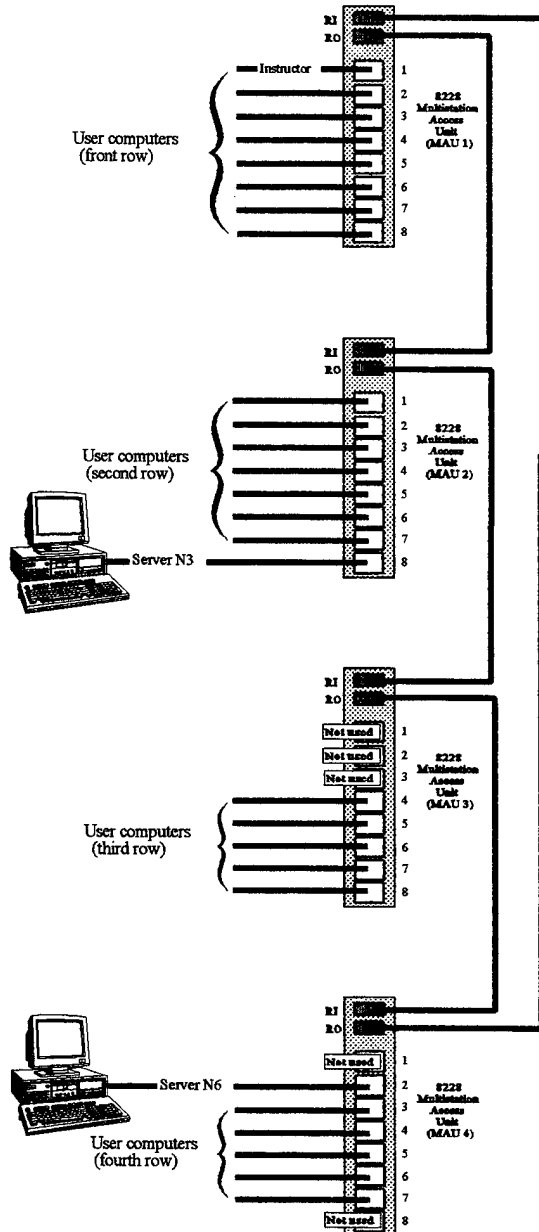

I-224 Token Ring LAN (4TR)

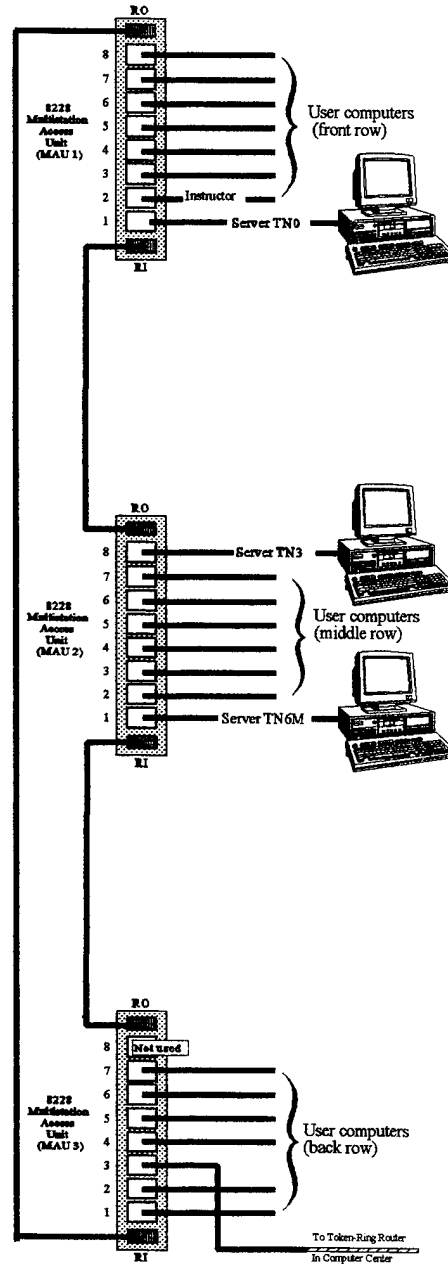

I- 158 Token Ring LAN (8TR)

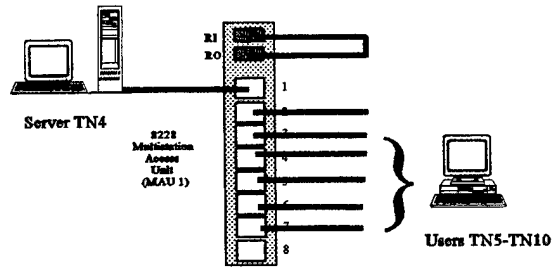

APPENDIX B. NETWORK HARDWARE TABLES

**I-250
OTR
Decision Support Lab**

| <i>Node</i> | <i>Vendor</i> | <i>Processor</i> | <i>RAM</i> | <i>Hard-Disk</i> | <i>Modem</i> | <i>Monitor</i> |
|----------------|---------------|------------------|------------|-------------------------------|--------------|----------------|
| N3 (server) | Bi Link | 486DX33 | 8Mb | 200Mb | | SVGA |
| N6 (server) | Bi Link | 486DX33 | 8Mb | 200Mb & 100Mb Hard Card | | SVGA |
| N9 | Bi Link | 486DX33 | 8Mb | 200Mb | y | SVGA |
| N10 | Bi Link | 486DX266 | 8Mb | 200Mb | y | SVGA |
| N11 | Bi Link | 486DX33 | 8Mb | 200Mb | y | SVGA |
| N12 | Bi Link | 486DX33 | 8Mb | 200Mb | y | SVGA |
| N13 | Bi Link | 486DX33 | 8Mb | 200Mb | y | SVGA |
| N14 | Bi Link | 486DX33 | 8Mb | 200Mb | y | SVGA |
| N15 | Bi Link | 486DX33 | 8Mb | 200Mb | y | SVGA |
| N16 | Bi Link | 486DX33 | 8Mb | 200Mb | | SVGA |
| N17 | Bi Link | 486DX33 | 8Mb | 200Mb | | SVGA |
| N18 | Bi Link | 486DX33 | 8Mb | 200Mb | | SVGA |
| N19 | Bi Link | 486DX33 | 8Mb | 200Mb | | SVGA |
| N20 | Bi Link | 486DX33 | 8Mb | 200Mb | | SVGA |
| N21 | Bi Link | 486DX33 | 8Mb | 200Mb | | SVGA |
| N22 | Bi Link | 486DX33 | 8Mb | 200Mb | | SVGA |
| N23 | Bi Link | 486DX33 | 8Mb | 200Mb | | SVGA |
| N24 | Bi Link | 486DX33 | 8Mb | 200Mb | | SVGA |
| N25 | Bi Link | 486DX33 | 8Mb | 200Mb | | SVGA |
| N26 | Bi Link | 486DX33 | 8Mb | 200Mb | | SVGA |
| N27 | Bi Link | 486DX33 | 8Mb | 200Mb | | SVGA |
| N28 | Bi Link | 486DX33 | 8Mb | 200Mb | | SVGA |
| N29 | Bi Link | 486DX33 | 8Mb | 200Mb | | SVGA |
| N30 | Bi Link | 486DX33 | 8Mb | 200Mb | | SVGA |
| N31 | Bi Link | 486DX33 | 8Mb | 200Mb | | SVGA |
| N32 | Bi Link | 486DX33 | 8Mb | 200Mb | | SVGA |

**I-224
4TR
Networks Lab**

| <i>Node</i> | <i>Vendor</i> | <i>Processor</i> | <i>RAM</i> | <i>Hard-Disk</i> | <i>Modem</i> | <i>Monitor</i> | <i>3270</i> | <i>Misc</i> |
|------------------------------------|---------------|------------------|------------|------------------|--------------|----------------|-------------|---------------|
| TN0 3270 Gateway (server) | IBM | 80286 | 1Mb | 30Mb | | Mono | | |
| TN1 3270 Gateway (server) | STANDARD | 80286 | 1Mb | 20Mb | | Mono | | |
| TN3 (Server) | BSM | 486DX33 | 8Mb | 200Mb | | SVGA | | 250Mb Tape |
| TN6M (Server) | BSM | 486DX33 | 8Mb | 200Mb | | SVGA | | Printer |
| TN18 | BSM | 486DX33 | 8Mb | 200Mb | y | SVGA | y | |
| TN20 | BSM | 486DX33 | 8Mb | 200Mb | y | SVGA | y | |
| TN21 | BSM | 486DX33 | 8Mb | 200Mb | y | SVGA | y | |
| TN22 | BSM | 486DX33 | 8Mb | 200Mb | y | SVGA | y | |
| TN23 | BSM | 486DX33 | 8Mb | 200Mb | | SVGA | y | |
| TN24 | BSM | 486DX33 | 8Mb | 200Mb | y | SVGA | y | |
| TN25 | BSM | 486DX33 | 8Mb | 200Mb | y | SVGA | y | Scanner |
| TN26 | BSM | 486DX33 | 8Mb | 200Mb | | SVGA | y | |
| TN27 | BSM | 486DX33 | 8Mb | 200Mb | | SVGA | y | |
| TN28 | Bi Link | 486DX33 | 8Mb | 200Mb | | SVGA | | |
| TN29 | Bi Link | 486DX33 | 8Mb | 200Mb | | SVGA | | |
| TN30 | Bi Link | 486DX33 | 8Mb | 200Mb | | SVGA | | |
| TN31 | Bi Link | 486DX33 | 8Mb | 200Mb | | SVGA | | |
| TN32 | Bi Link | 486DX33 | 8Mb | 200Mb | | SVGA | | |
| TN33 | Bi Link | 486DX33 | 8Mb | 200Mb | | SVGA | | |
| TN34 | Bi Link | 486DX33 | 8Mb | 200Mb | | SVGA | | |
| TN35 | Bi Link | 486DX33 | 8Mb | 200Mb | | SVGA | | |
| TN36 | Bi Link | 486DX33 | 8Mb | 200Mb | | SVGA | | CD ROM |
| TN37 | Bi Link | 486DX33 | 8Mb | 200Mb | | SVGA | | |

I-158
8TR
Software Metrics Lab

| <i>Node</i> | <i>Vendor</i> | <i>Processor</i> | <i>RAM</i> | <i>Hard-Disk</i> | <i>Monitor</i> | <i>Misc</i> |
|-----------------|---------------|------------------|------------|------------------|----------------|-------------|
| TN4 (Server) | Data Store | 486DX266 | 8Mb | 500Mb | SVGA | Printer |
| TN5 | BSM | 486DX33 | 8Mb | 600Mb | SVGA | Printer |
| TN6 | BSM | 486DX33 | 8Mb | 200Mb | SVGA | |
| TN7 | BSM | 486DX33 | 8Mb | 200Mb | SVGA | |
| TN8 | BSM | 486DX266 | 8Mb | 200Mb | SVGA | |
| TN9 | Data Store | 486DX266 | 8Mb | 200Mb | SVGA | |
| TN10 | Data Store | 486DX266 | 8Mb | 200Mb | SVGA | |
| TN11 | BSM | 486DX266 | 8Mb | 200Mb | SVGA | |

APPENDIX C. EXISTING SERVER DIRECTORY MAPS

Directory PATH listing for Volume SERVER N3

C:
-DOS
-QEMMOLD
-TAPE
-NETWORK
-MOUSE
-WINDOWS
-SYSTEM
-TVGAUTIL
-UTILITY
-CONTENT
-ACAD
-ACAD386
-VCADP
-LOTUS
-WP51
-WORD
-WORD55
-QPRO
-MSOFFICE
-QEMM
-SIMPC60
-QLII
-SAVEBATT
-APPS
-DOS
-DATABASE
-DBASE4
-SQLHOME
-SAMPLES
-PDOX35
-SAMPLE
-SAMPAPP
-PPROG
-VIDEO
-TOOLKIT
-UTIL
-PROTECT
-TOOLS
-VIRUS
-DBNETCTL.300
-COMM
-SIMPC60
-SPREDSHT
-LOTUS
-LOTUS23
-WYSIWYG
-TUTOR
-WYSYGO
-WPC20
-TRUETYPE
-QFINDEX
-AFAM
-AFAMSUP
-AFAMEXEC
-AFAMTUTR
-AFAMPHAS
-PHASE0
-PHASE1
-PHASE2
-PHASE3
-PHASE4
-PHASE5
-AFAMXTRA
-AFAMLOCL
-LOCAL0
-LOCAL1
-LOCAL2
-LOCAL3
-LOCAL4
-LOCAL5
-WINDOWS
-WINUSER.SET
-WPWIN60
-TEMPLATE
-MACROS
-LEARN

- GRAPHICS
- WPDRAW
- WPCNET
- DECISION
- CRITERUM
- STRAD
- TUTOR
- DEMOS
- LDW
- MESSGES
- LOTUS
- FLW
- MASTERS
- TUTORIAL
- 123R5W
- PROGRAMS
- SHEETICO
- TRANSICO
- PREVICO
- GRAPHICO
- DRAWICO
- DQAICO
- ADDINS
- CB
- EXAMPLES
- MAPDATA
- LIBRARY
- TOUR
- 123WXMAC
- MASTERS
- SAMPLE
- MAPS
- TUTORIAL
- SOLVER
- VERSMGR
- DBASE
- LOTUSAPP
- DIALOGED
- MULTIMED
- SPELL
- HELP
- FILTERS
- DATALENS
- EXCELFLT
- UNS
- WINSYS
- WIN
- LICENSER
- USER.SET
- 123R5W
- MASTERS
- SAMPLE
- VERSMGR
- DBASE
- SOLVER
- PROGRAMS
- SHEETICO
- DRAWICO
- DQAICO
- GRAPHICO
- PREVICO
- TRANSICO
- ADDINS
- WORK
- FLW
- SUITE
- OLDBAT
- LICENSES.DIR
- LOTSHARE
- 123.V23
- 123W.V50
- SUITE
- FLW.V10
- SPARE.LIC
- IDIRPLUS
- BAT
- TCP
- PCTCP

Directory PATH listing for Volume SERVER N6

```
C:
├──DOS
├──NETWORK
├──TAPE
├──APPS
├──DOS
├──SH40
├──DATABASE
│   ├──PDOXWIN
│   │   ├──DIVEPLAN
│   │   ├──EXAMPLES
│   │   ├──WORKING
│   │   ├──PRIVATE
│   │   ├──SAMPLE
│   │   └──PDOX35SA
│   │       ├──SAMPLE
│   │       ├──SAMPAPP
│   │       ├──PPROG
│   │       ├──VIDEO
│   │       ├──PROTECT
│   │       ├──TOOLKIT
│   │       └──UTIL
│   ├──WORDPROC
│   │   ├──WP60
│   │   │   ├──LEARN
│   │   │   ├──MACROS
│   │   │   └──GRAPHICS
│   │   ├──WP51
│   │   ├──WPC60DOS
│   │   ├──OFFICE
│   │   │   ├──SHARED
│   │   │   └──TEXTART
│   │   ├──WPC20
│   │   │   ├──TRUETYPE
│   │   │   └──OLE2
│   │   └──WPCNET
│   ├──ACOL
│   ├──GRAPHICS
│   │   └──STORYBRD
│   ├──BTFONTS
│   ├──PSFONTS
│   ├──ODAPI
│   ├──WINDOWS
│   ├──DATAWIN
│   ├──STATISTS
│   │   └──MTBWIN
│   │       ├──DATA
│   │       ├──MACROS
│   │       ├──STUDENT1
│   │       ├──STUDENT8
│   │       ├──DATA
│   │       ├──EXPLORE
│   │       ├──GETSTART
│   │       ├──TUT1
│   │       ├──TUT2
│   │       ├──TUT3
│   │       ├──TUT4
│   │       ├──TUT5
│   │       ├──TUT6
│   │       ├──TUT7
│   │       ├──TUT8
│   │       ├──TUT9
│   │       ├──TUT10
│   │       ├──TUT11
│   │       ├──TUT12
│   │       ├──TUT13
│   │       ├──TUT14
│   │       └──STUDENT9
│   ├──POFFICE
│   │   ├──WPWIN61
│   │   │   ├──TEMPLATE
│   │   │   ├──BUSINESS
│   │   │   ├──CALENDAR
│   │   │   ├──ENVELOPE
│   │   │   └──FAX
```

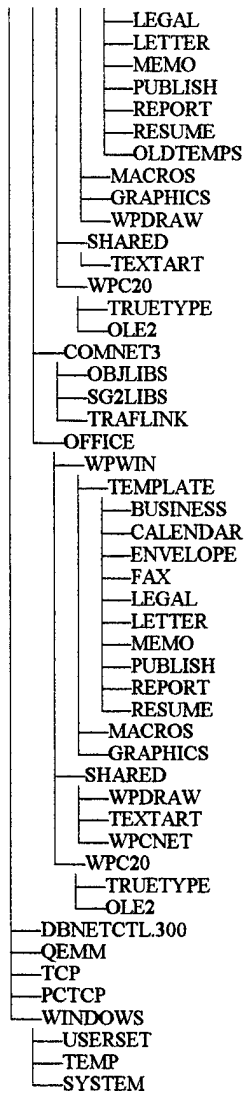

Directory PATH listing for Volume TN6M SYS

```
C:
├──DOS
├──TN36BKUP
├──NETWORK
├──QEMM
├──APPS
│   ├──DOS
│   ├──SGPLUS
│   └──DRIVERS
│       └──DATA
├──1DIRPLUS
├──SIMPC60
├──SCSIOLD
├──WA
│   └──SCRWOR
├──CDMENU
├──EE
├──TIMEMAG
├──TCP
├──MAINFRAM
├──SCSI
├──JOPESCAI
├──TN18BKUP.C
│   ├──APPS
│   ├──DOS
│   ├──COMM
│   │   └──SIMPC60
│   ├──SGPLUS
│   └──DRIVERS
│       └──DATA
├──QEMM
├──TCPIP
├──DATA
├──MAINFRAM
├──SIMPC60
├──MOUSE
├──NETWORK
├──1DIRPLUS
├──PCTCP
├──MAIL
├──USER
├──NETWORK
├──TAPE
├──APPS
│   ├──DOS
│   ├──TOOLS
│   ├──ISTAR
│   ├──VIRUS
│   ├──DATABASE
│   ├──WORDPROC
│   │   └──WP51
│   ├──ACOL
│   ├──GRAPHICS
│   │   └──STORYBRD
│   ├──STATG
│   │   ├──DATA
│   │   └──DRIVERS
│   ├──AFAMSUP
│   ├──SPLUSOLD
│   │   ├──DRIVERS
│   │   └──DATA
│   ├──AFAMEXEC
│   │   └──AFAMTUTR
│   ├──AFAMPHAS
│   │   ├──PHASE0
│   │   ├──PHASE1
│   │   ├──PHASE2
│   │   ├──PHASE3
│   │   ├──PHASE4
│   │   └──PHASE5
│   └──AFAMLOCL
│       ├──LOCAL0
│       ├──LOCAL1
│       └──LOCAL2
```

- LOCAL3
- LOCAL4
- LOCAL5
- AFAMXTRA
- TCPIP
- DBNETCTL.300
- QEMM
- TN18BKUP.D
 - APPS
 - DATABASE
 - PDOX35
 - SAMPLE
 - SAMPAPP
 - PPROG
 - VIDEO
 - PROTECT
 - TOOLKIT
 - UTIL
- JOPECAI
- PDOXDATA
- BATCH
- TN37BKUP
 - MOUSE
 - SCSI
 - AFDISK
 - TAPE
 - APPS
 - DOS
 - SGPLUS
 - DRIVERS
 - DATA
- 1DIRPLUS
- NETWORK
- QEMM
- MAINFRAM
- TCP
- TCP
- HJ2
- PCTCP

Directory PATH listing for Volume TN3 SYS

```

C:
├── APPS
│   ├── DOS
│   ├── DATABASE
│   │   └── PDOX40
│   │       ├── WORKSHOP
│   │       ├── SAMPAPP
│   │       ├── SAMPLE
│   │       ├── VIDEO
│   │       └── CFG
│   ├── TOOLS
│   ├── VIRUS
│   ├── COMM
│   ├── SIMPC60
│   ├── SPREDSHT
│   │   ├── LOTUS
│   │   └── LOTUS23
│   │       ├── WYSIWYG
│   │       ├── TUTOR
│   │       └── WYSYGO
│   ├── MESSAGES
│   ├── RELIABIL
│   │   └── SMERFS
│   ├── WINDOWS
│   ├── SGTEMP
│   │   ├── DRIVERS
│   │   └── DATA
│   ├── SGPLUS
│   │   ├── DRIVERS
│   │   └── DATA
│   ├── TCP
│   ├── OLDBAT
│   ├── LICENSES.DIR
│   │   ├── LOTSHARE
│   │   └── 123.V23
│   └── LICENSES.SPR
├── TAPE
├── BAT
├── QAPLUS
├── NETWORK
├── DOS
├── QEMM
├── MOUSE
├── 1DIRPLUS
├── PCTCP
│   └── MAIL
│       ├── SPOOL
│       └── USER
├── TN20BKUP.C
│   ├── APPS
│   │   ├── DOS
│   │   ├── COMM
│   │   │   └── SIMPC60
│   │   ├── SGPLUS
│   │   │   ├── DRIVERS
│   │   │   └── DATA
│   ├── MAINFRAM
│   ├── QEMM
│   ├── MOUSE
│   ├── 1DIRPLUS
│   ├── SIMPC60
│   ├── NETWORK
│   ├── PCTCP
│   │   └── MAIL
│   │       └── USER
│   ├── TEMP
│   ├── MAIL
│   └── TCPIP
├── TN29BKUP.D
│   ├── JOPESCAI
│   │   └── PA
│   │       ├── COMM.DIR
│   │       ├── DRIVERS
│   │       └── MOH-2

```

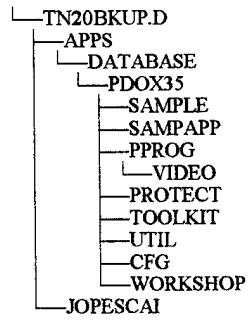

APPENDIX D. PENTIUM SERVER DIRECTORY MAPS

Directory PATH listing for Volume PN3 SERVER

C:
-APPS
-COMM
-SIMPC60
-WPOFFICE
-WPWIN
-TEMPLATE
-BUSINESS
-CALENDAR
-ENVELOPE
-FAX
-LEGAL
-LETTER
-MEMO
-PUBLISH
-REPORT
-RESUME
-MACROS
-GRAPHICS
-SHARED
-WPDRAW
-TEXTART
-WPCNET
-WPC20
-TRUETYPE
-OLE2
-AFAM
-AFAMSUP
-AFAMEXEC
-AFAMTUTR
-AFAMPHAS
-PHASE0
-PHASE1
-PHASE2
-PHASE3
-PHASE4
-PHASE5
-AFAMXTRA
-DECISION
-CRITERUM
-STRAD
-TUTOR
-DEMOS
-LDW
-MESSAGES
-LOTUS
-FLW
-MASTERS
-TUTORIAL
-123R5W
-PROGRAMS
-SHEETICO
-TRANSICO
-PREVICO
-GRAPHICO
-DRAWICO
-DQAICO
-ADDINS
-CB
-EXAMPLES
-MAPDATA
-LIBRARY
-TOUR
-123WXMAC
-MASTERS
-SAMPLE
-MAPS
-TUTORIAL
-SOLVER
-VERSMGR
-DBASE
-LOTUSAPP
-DIALOGED
-MULTIMED
-SPELL
-HELP
-FILTERS

- DATALENS
- EXCELFLT
- UNS
- WINSYS
- WIN
- LICENSER
- USER.SET
- 123R5W
 - MASTERS
 - SAMPLE
 - VERSMGR
 - DBASE
 - SOLVER
 - PROGRAMS
 - SHEETICO
 - DRAWICO
 - DQAICO
 - GRAPHICO
 - PREVICO
 - TRANSICO
- FLW
- SPREDSHT
 - LOTUS
 - LOTUS23
 - WYSIWYG
 - TUTOR
 - WYSYGO
- RELIABIL
 - SMERFS
- SGPLUS
- DRIVERS
- DATA
- DOS
 - DATA
 - SYSTEM
 - EPP
- WINDOWS
 - SYSTEM
 - WIN32S
 - DRIVERS
 - ICONS
 - OPTIONS
- WELCOME
- BITMAPS
- BOOKS
- FLC
- IBMTOOLS
 - WINRESET
- MOUSE
- AVPRO
- READIBMW
- WNETFIN
- QAPLUSP
- QAPLUSVP
- CSW
- FACTORY
- MONOLOGW
- PROMO
- PROVW20
- VOICEMGR
 - BIN
 - DOC
 - MAP
 - MODEL
 - US_ENG
 - MEDIUM
 - RULES
- VOYETRA
 - SONGS
 - SOUNDS
 - WINAPPS
- WIN32APP
 - FREECELL
- NETWORK
- LICENSES.DIR
 - LOTSHARE
 - 123.V23
 - 123W.V50
 - FLW.V10
 - SPARE.LIC
- QEMM
- 1DIRPLUS
- BAT
- TCP

- PCTCP
- NETWORK.134
- NETWORK.133
- NETWORK.120
- TEMP
- SYSTEM
- TEMPLATE

Directory PATH listing for Volume PN6 SERVER

```
C:
├──PCDOS
│   ├──DATA
│   ├──SYSTEM
│   └──EPP
├──WINDOWS
│   ├──SYSTEM
│   │   ├──WIN32S
│   │   ├──DRIVERS
│   │   ├──ICONS
│   │   └──OPTIONS
│   ├──WELCOME
│   └──BITMAPS
├──BOOKS
├──FLC
├──IBMTOOLS
│   └──WINRESET
├──MOUSE
├──AVPRO
├──READIBMW
├──WNETFIN
├──QAPLUSP
├──QAPLUSVP
├──CSW
├──FACTORY
├──MONOLOGW
├──PROMO
├──PROVW20
├──VOICEMGR
│   ├──BIN
│   ├──DOC
│   ├──MAP
│   ├──MODEL
│   └──US_ENG
│       └──MEDIUM
│           └──RULES
├──VOYETRA
│   ├──SONGS
│   ├──SOUNDS
│   └──WINAPPS
├──WIN32APP
│   └──FREECELL
├──NETWORK.120
├──APPS
│   ├──TOOLS
│   │   ├──ISTAR
│   │   ├──VIRUS
│   │   └──QAPLUS
│   ├──ACOL
│   ├──AFAMSUP
│   ├──SH40
│   ├──DATABASE
│   └──PDOXWIN
│       ├──WORKGRP
│       ├──EXAMPLE5
│       ├──DIVEPLAN
│       ├──EXAMPLES
│       ├──WORKING
│       ├──SAMPLE
│       ├──PRIVATE
│       ├──SAMPLE5
│       ├──CONNECT
│       ├──EXPERTS
│       ├──TSAMPLE
│       └──PDOXDATA
├──WORDPROC
│   ├──WP60
│   │   ├──LEARN
│   │   ├──MACROS
│   │   └──GRAPHICS
│   ├──WP51
│   ├──WPC60DOS
│   ├──OFFICE
│   │   ├──SHARED
│   │   └──TEXTART
│   ├──WPC20
│   │   ├──TRUETYPE
│   │   └──OLE2
│   └──WPCNET
├──BTFONTS
└──PSFONTS
```

- ODAPI
- DATAWIN
- STATISTS
- MTBWIN
 - DATA
 - MACROS
 - STUDENT1
 - STUDENT8
 - DATA
 - EXPLORE
 - GETSTART
 - TUT1
 - TUT2
 - TUT3
 - TUT4
 - TUT5
 - TUT6
 - TUT7
 - TUT8
 - TUT9
 - TUT10
 - TUT11
 - TUT12
 - TUT13
 - TUT14
- STUDENT9
- OFFICE
 - WPWIN
 - TEMPLATE
 - BUSINESS
 - CALENDAR
 - ENVELOPE
 - FAX
 - LEGAL
 - LETTER
 - MEMO
 - PUBLISH
 - REPORT
 - RESUME
 - MACROS
 - GRAPHICS
 - SHARED
 - WPDRAW
 - TEXTART
 - WPCNET
- PARADOX5
- IDAPI
- OBEX
 - BIN
 - OBJSTORE
- QEMM
- BACKUPS
 - ROOTFYLS
 - TN6
 - TN5
- TCP
- PCTCP
- DOS
- NETWORK
- TEMP

- WELCOME
 - BITMAPS
- BOOKS
- FLC
- IBMTOOLS
 - WINRESET
- MOUSE
- AVPRO
- READIBMW
- WNETFIN
- QAPLUSP
- QAPLUSVP
- CSW
- FACTORY
- MONOLOGW
- PROMO
- PROVW20
- VOICEMGR
 - BIN
 - DOC
 - MAP
 - MODEL

- ├──US_ENG
- │ ├──MEDIUM
- │ └──RULES
- ├──VOYETRA
- ├──SONGS
- ├──SOUNDS
- ├──WINAPPS
- ├──WIN32APP
- │ └──FREECELL
- ├──NETWORK
- ├──LICENSES.DIR
- │ ├──LOTSHARE
- │ │ ├──123.V23
- │ │ ├──123W.V50
- │ │ └──FLW.V10
- │ └──SPARE.LIC
- ├──QEMM
- ├──1DIRPLUS
- ├──BAT
- ├──TCP
- ├──PCTCP
- ├──NETWORK.134
- ├──NETWORK.133
- ├──NETWORK.120
- ├──TEMP
- ├──SYSTEM
- └──TEMPLATE

APPENDIX E. UPDATED SYSTEM FILES

```
rem  SERVER PN3 CONFIG.SYS FOR INTEGRATED TOKEN RING NETWORK
rem  VERSION: 1.0 dtd 21 Jun 1995
rem  PREVIOUS VERSION: None, but this version was developed from a similar
rem  file on Server 0TRN3 (VERSION: 250TR1.31 dtd 5 Jan 1995).
rem  21 Jun 1995, lrs. Environment size changed from 512KB to 256KB to
rem  recover unused memory space.
SHELL=C:\COMMAND.COM/P/E:256
DEVICE=C:\QEMM\QEMM386.SYS RAM ARAM=D800-DBFF AROM=CC00-CDFF
DOS=HIGH
DEVICE=C:\QEMM\LOADHI.SYS /H C:\NETWORK\DXMA0MOD.SYS 001
DEVICE=C:\QEMM\LOADHI.SYS /H C:\NETWORK\DXMC0MOD.SYS
DEVICE=C:\QEMM\LOADHI.SYS /H C:\NETWORK\DXMT0MOD.SYS ST=57 S=63 C=19
ES=1
DEVICE=C:\QEMM\LOADHI.SYS /H C:\MOUSE\MMOUSE.SYS
DEVICE=C:\QEMM\LOADHI.SYS /H C:\DOS\SETVER.EXE
rem  21 Jun 1995, lrs. The following device command creates a temporary
rem  place holder for this server's second hard disk, which is on order.
DEVICE=C:\QEMM\LOADHI.SYS /H C:\DOS\RAMDRIVE.SYS 128/E
rem  21 Jun 1995, lrs. The following device commands create the NETWORK
rem  and BATCH FILE RAMDISKS (respectively) which are used in the normal
rem  operation of the network.
DEVICE=C:\QEMM\LOADHI.SYS /H C:\DOS\RAMDRIVE.SYS 512/E
DEVICE=C:\QEMM\LOADHI.SYS /H C:\DOS\RAMDRIVE.SYS 196/E
DEVICE=C:\DOS\SMARTDRV.EXE 6144
LASTDRIVE=G
BUFFERS=20
rem  21 Jun 1995, lrs. Experience with Caryl's classes using MS Windows
rem  applications shows that the number of file handles on a server should
rem  be set to the maximum possible value (255).
FILES=255
FCBS=1
```

```

::***SERVER PN3 AUTOEXEC.BAT FOR SM TOKEN RING NETWORK
:: VERSION 1.0 dtd 21 Jun 1995
PATH E:\;C:\DOS;C:\QEMM;C:\;C:\BAT;C:\NETWORK;C:\PCTCP;D:\;D:\DOS
LOADHI /H FCBS=8
LOADHI /H C:\DOS\FASTOPEN.EXE C:=200/X
SET TEMP=C:\TEMP
SET DIRCMD=/O/P
LOADHI /H C:\DOS\DOSKEY
LOADHI /H C:\NETWORK\SHARE.EXE
XCOPY C:\NETWORK\*.* E:
:: 28 Jul 1995, lrs. Command XCOPY C:\DOS\COMMAND.COM E: removed (not
:: needed). There are no references to this file in the NETWORK
:: directory by any user files.
ATTRIB +R E:\*.*
:: 28 Jul 1995, lrs. Command SET COMSPEC =E:\COMMAND.COM removed (not
:: needed). There are no references to this file in the NETWORK
:: directory by any user files.
LABEL E:NETFILES
XCOPY C:\DIRPLUS\1DIRPLUS.EXE F:
XCOPY C:\BAT\*.* F:
ATTRIB +R F:\*.*
LABEL F:BATCHDIR
NET START SRV PN3 /SHR:15/RQB:16K/PRB:16K/RDR:57/CMD:19/SES:63/REQ:3/TSI:00
NET SHARE APPS=C:\APPS /R
NET SHARE BATFILES=F: /RW
NET SHARE LOTSHARE=C:\LICENSES.DIR\LOTSHARE /RWC
:: THE FOLLOWING NET SHARE COMMAND IS A BACKUP FOR PN6
::NET SHARE APPS1=D:\APPS /R
C:
::VSHIELD /ACCESS /M
::c:\IBMTOOLS\ibmpfile.exe
PROMPT $P$G
SET PCTCP=C:\PCTCP\PCTCP.INI
IBMTR

```

```
rem USER (TN32) CONFIG.SYS FOR INTEGRATED TOKEN-RING NETWORK
rem VERSION: 1.0 dtd 21 Jun 1995
rem PREVIOUS VERSION: None, but this version developed
rem from a similar file (Version 250TR1.2 dtd 3 Jan 1995).
rem 21 Jun 1995, lrs. Enviornment size changed from 512KB to 256KB to
rem recover unused memory space.
SHELL=C:\COMMAND.COM/P/E:256
DEVICE=C:\QEMM\QEMM386.SYS RAM ARAM=D800-DBFF AROM=CC00-CDFF
DOS=HIGH
DEVICE=C:\QEMMLOADHI.SYS /H C:\NETWORK\DXMA0MOD.SYS 001
DEVICE=C:\QEMMLOADHI.SYS /H C:\NETWORK\DXMC0MOD.SYS
rem 21 Jun 1995, pjm. DXMT0MOD.SYS parameters derived as follows;
rem ST=max NETBIOS interface links for user computer = # of Servers+1 =6
rem S=SES setting in NET START command in start.bat = 25
rem C=CMD setting in NET START command in start.bat = 8
rem ES=additional SAPs requested by NETBIOS driver when it opens adapter = 1
DEVICE=C:\QEMMLOADHI.SYS /H C:\NETWORK\DXMT0MOD.SYS ST=6 S=25 C=8
ES=1
DEVICE=C:\QEMMLOADHI.SYS /H C:\MOUSE\MMOUSE.SYS
DEVICE=C:\QEMMLOADHI.SYS /H C:\APPS\DOS\SETVER.EXE
DEVICE=C:\QEMMLOADHI.SYS /H C:\APPS\DOS\ANSI.SYS
LASTDRIVE=E
BUFFERS=20
FILES=30
FCBS=1
```

```
:: AUTOEXEC.BAT (TN32) FOR 224 TOKEN RING NETWORK
:: VERSION: 1.0 dtd 21 Jun 1995
:: PREVIOUS VERSION
:: ENVIORNMENT: DOS: MS-DOS v.5.0, NOS: IBM PC LAN Program V. 1.21
:: OBJECTIVE: Configure user computer defaults and files for network
:: INPUT/INITIAL CONDITIONS:None/Executes after CONFIG.SYS to complete
:: system configuration for network user operation
:: OUTPUT/RESULTS:
:: WHERE STORED: In root of user TN32 Drive C:
:: CALLS: The IBM PC LAN START command
:: CALLED BY: The Disk Operating System during system startup.
:: COMMENTS
```

cls

@ECHO OFF

SET 1DIRPLUS=C:\1DIRPLUS

SET MONITOR=VGA

SET MATH=Y

SET MODEM=N

SET EMULATION=N

SET PRTSRVR=TN6M

SET ALTPRTSRVR=N6

SET P=C:\NETWORK;C:\WINDOWS;C:\APPS\DOS;C:\;C:\1DIRPLUS;C:\PCTCP;C:\QEMM
PATH %P%

LOADHI /H C:\APPS\DOS\FASTOPEN.EXE C:=50 /X

LOADHI /H FILES+20

LOADHI /H FCBS=8

LOADHI /H LASTDRIV=M

LOADHI /H C:\WINDOWS\SMARTDRV.EXE

SET COMSPEC=C:\COMMAND.COM

PROMPT \$P\$G

VSHIELD /M /CHKHI /LOCK /CONTACT "CONTACT THE LAB STAFF OR THE
DEPARTMENT SECRETARY" /SWAP

NEWUSER

SHARE

```

:: 4TR USER START.BAT FOR SM INTEGRATED NETWORK
:: VERSION: 1.0 dtd 21 JUN 1995
:: PREVIOUS VERSION:None
:: ENVIORNMENT: DOS: MS-DOS v.6.0, NOS: IBM PC LAN Program v.1.33
:: OBJECTIVE: Use network resources
:: INPUT/INIAL CONDITIONS: None/Executes when user executes START command
:: at workstation
:: OUTPUT/RESULTS: Directs user computer to use resources shared by servers PN3, PN6
:: and TN6M.
:: WHERE STORED: In root of User TNXX Drive C:.
:: CALLS: The IBM PC LAN START command
:: CALLED BY: User command
:: COMMENTS:

```

```
@ECHO OFF
```

```
CLS
```

```
STRMSG
```

```

:: 21 Jun 1995, pjm. Command NET START parameters computed from Prof
:: Schneidewinds IS-3105 notes as follows;
:: SRV= max # of servers user computer can use = 5
:: ASG= max # of server resources user computer can use = # of NET USE
:: commands in this batch file = 7
:: PB1= PBX<=PRB = 15K (PRB=16K)
:: PB2= (PB1 +PB2) <= 16K therefore PB2 = 1K
:: CMD= max # of net commands issued by user computer in this batch file
:: (plus 4 if user computer uses 3270 Emulation) = 8 (8 net commands, no 3270)
:: SES= max # active sessions of user computer with servers: Estimate 5*SRV
:: (plus 2 if user computer uses 3270 Emulation) = 5*5 = 25 (no 3270)

```

```
NET START RDR %1 /SRV:5 /ASG:7 /PB1:15K /PB2:1K /CMD:8 /SES:25
```

```
IF ERRORLEVEL 1 GOTO NOTICE
```

```
NET USE I: \\PN3\APPS
```

```
IF ERRORLEVEL 1 GOTO PN3_FAIL
```

```
NET USE F: \\PN3\BATFILES
```

```
NET USE J: \\PN6\APPS
```

```
IF ERRORLEVEL 1 GOTO PN6_FAIL
```

```
GOTO PRINTER_SETUP
```

```

:: 21 Jun 1995, pjm. The following module swithes the user to the D: hard disk on PN6
:: in the event of a failure of PN3. The "F" and "I" drives on PN6 are
:: are identical to those on PN3.

```

```
:PN3_FAIL
```

```
SRVRFail
```

```
PAUSE
```

```
NET USE F: \\PN6\BATFILES
IF ERRORLEVEL 1 GOTO BOTH_FAIL
NET USE I: \\PN6\APPS1
GOTO PRINTER_SETUP
```

```
:: 21 Jun 1995, pjw. The following module switches the user to the D: hard disk on PN3
:: in the event of a failure on PN6. The "J" drive on PN3 is identical
:: to that on PN6. NET USE J: IS COMMENTED OUT UNTIL NEW HARD DISK
ARRIVES
```

```
:PN6_FAIL
SRVRFAIL
PAUSE
::NET USE J: \\PN3\APPS1
GOTO PRINTER_SETUP
```

```
:: 21 Jun 1995, pjw. The following module displays a message and exits the program
:: in the event both servers fail.
```

```
::
:BOTH_FAIL
NETFAIL
PAUSE
GOTO EXIT
```

```
:: 21 Jun 1995, pjw. The following module allows use of the resident printer server, and
:: a K drive.
```

```
:PRINTER_SETUP
NET USE LPT1 \\%PRTSRVR%\PRINT
NET USE K: \\%ALTPRTSRVR%\USER
IF ERRORLEVEL 1 GOTO PRINT_FAIL
GOTO END
```

```
:: 21 Jun 1995, pjw. The following module allows use of the alternate printer server in
:: the event that the resident printer server fails.
```

```
:PRINT_FAIL
ECHO THE PRINT SERVER HAS FAILED, "NOTIFY LAB STAFF". IF YOU ELECT TO
PRINT
ECHO YOUR PRINT JOBS WILL BE PRINTED IN THE OTHER SM LAB. (250 OR 224)
PAUSE
NET USE LPT1 \\%ALTPRTSRVR%\PRINT
IF ERRORLEVEL 1 GOTO PRN_FAIL2
```

GOTO END

:: 21 Jun 1995, pjw. The following module displays a message in the event of both print
:: servers failing.

:PRN_FAIL2
ECHO BOTH PRINT SERVERS HAVE FAILED, "NOTIFY LAB STAFF"
PAUSE
GOTO END

:NOTICE
USERFAIL
PAUSE
GOTO EXIT

:END
SET PCTCP=C:\PCTCP\PCTCP.INI
IBMTR
f

:EXIT
1DIRPLUS

APPENDIX F. LAN CABLING MAP

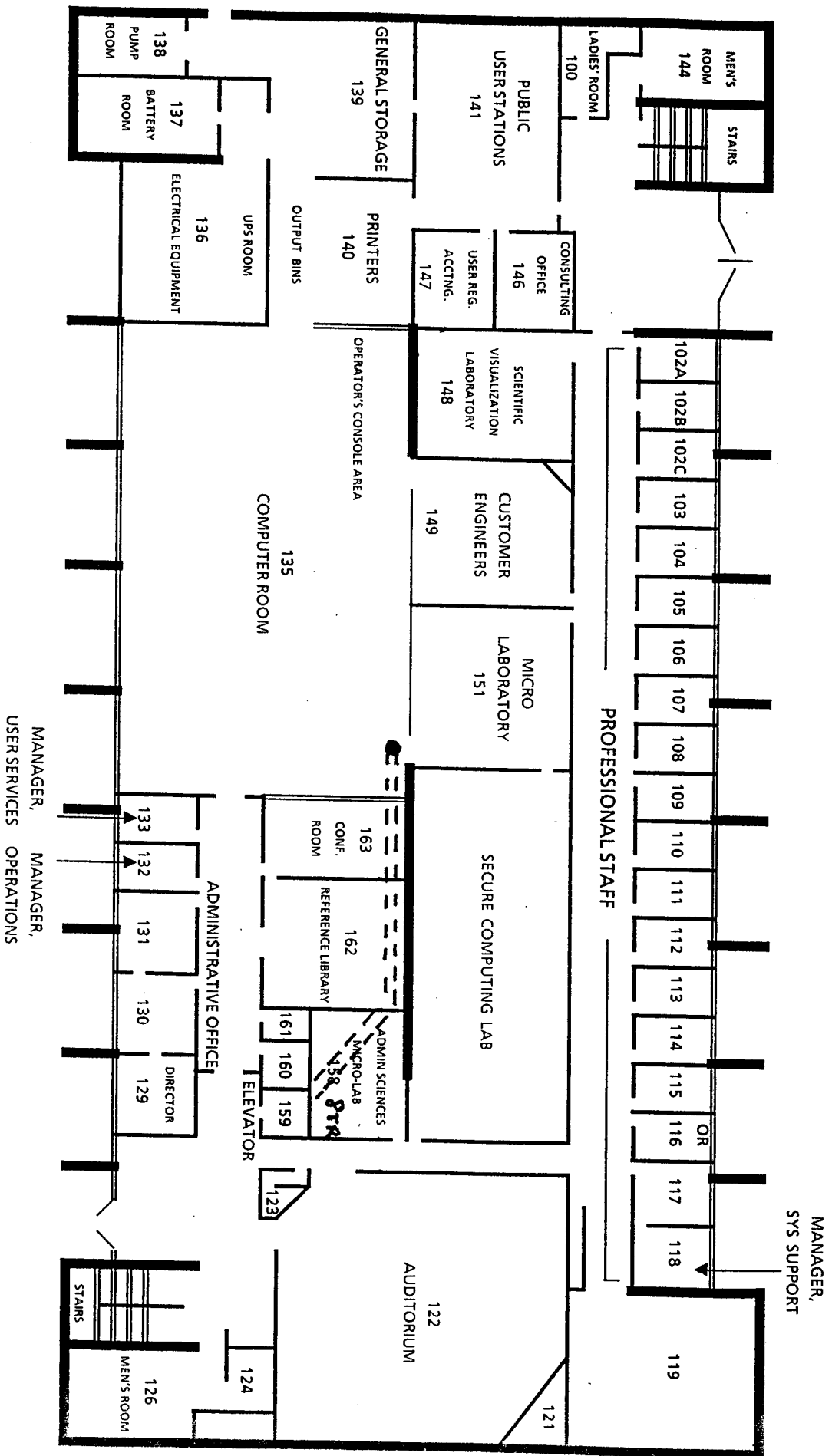

**APPENDIX G.
INTEGRATED LAN DIAGRAM**

**I- 250
Token Ring LAN
(0TR)**

**I- 224
Token Ring LAN
(4TR)**

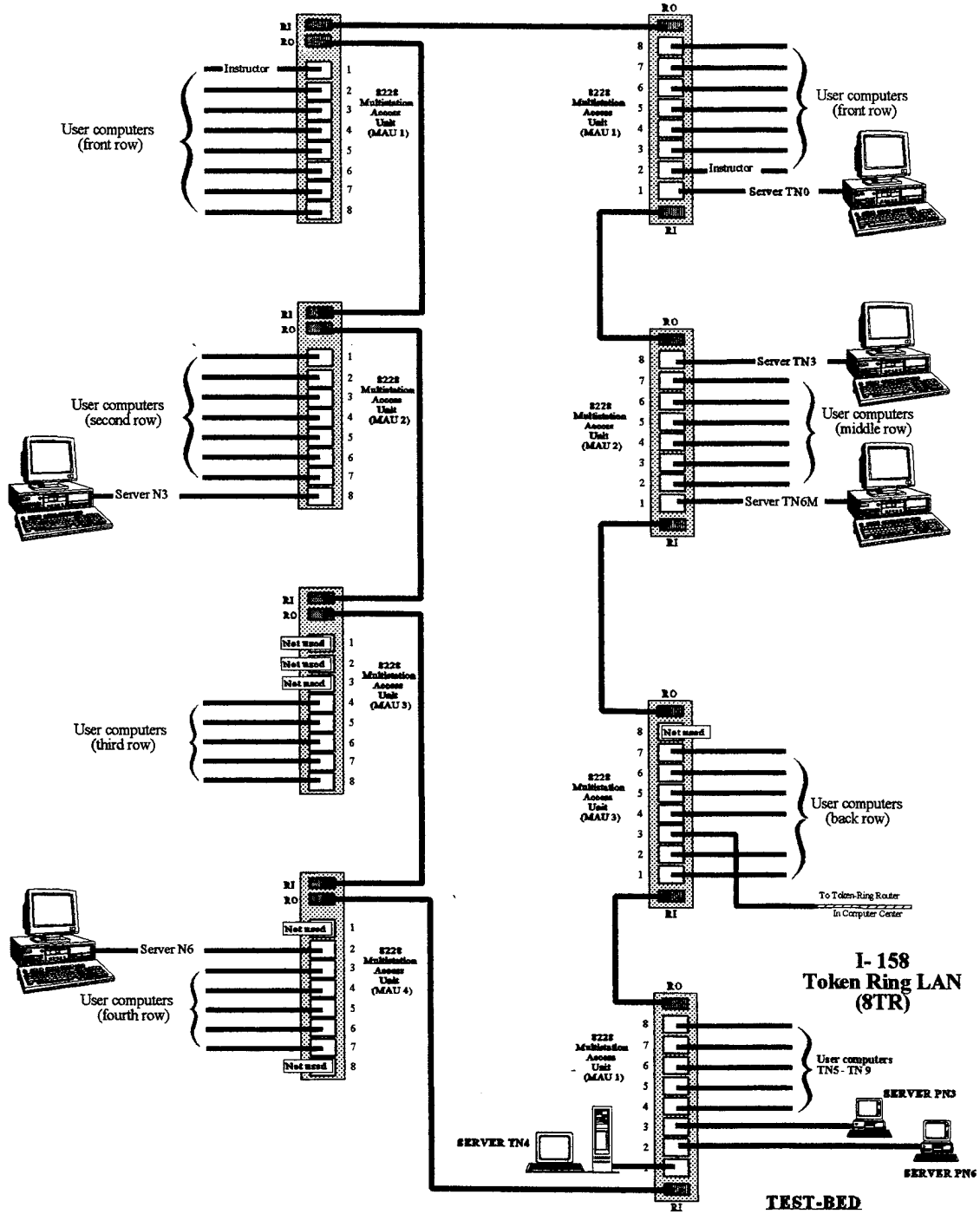

LIST OF REFERENCES

- [Abrahams] John, R., *Token Ring Networks: Design, Implementation and Management*, NCC Blackwell Limited, 1991
- [Feibel] Werner, *Novells Complete Encyclopedia of Networking*, Sybex Inc., 1995
- [Goodman] John M., *Memory Management For All of Us*, SAMS, Prentice Hall Publishing, 1992
- [IBM] IBM PC Local Area Network Program, International Business Machine, 1986
- [Katzan] Harry Jr., *Local aea Networks: A Managers Guide*, Carnegie Press, Inc., 1983
- [Microsoft] Microsoft MS-DOS Operating System Version 5.0, Users Guide and Reference, Unitron Computer U.S.A. Inc., 1992
- [Quarterdeck] Quarterdeck Epaned Memory Manager, Quarterdeck Office Systems, 1991
- [Schneidewind 1] Schneidewind, Norman, Naval Postgraduate School, IS-3502 Classroom Handout, 1995
- [Schneidewind 2] Schneidewind, Norman, Naval Postgraduate School, Interview with the Author, July 10, 1995

INITIAL DISTRIBUTION LIST

| | No. Copies |
|--|------------|
| 1. Defense Technical Information Center Cameron Station Alexandria, Virginia 22304-6145 | 2 |
| 2. Library, Code 52 Naval Postgraduate School Monterey, California 93943-5101 | 2 |
| 3. Professor Norman Schneidewind Department Of Systems Management, Code SM/Ss Naval Postgraduate School Monterey, CA 93943-5103 | 1 |
| 4. Professor Rex Buddenberg Department Of Systems Management, Code SM/Bu Naval Postgraduate School Monterey, CA 93943-5103 | 1 |
| 5. Commandant (G-L) U.S. Coast Guard 2100 2nd St., S.W. Washington DC 20593-0001 | 1 |
| 6. Commandant (G-TP-2) U.S. Coast Guard 2100 2nd St., S.W. Washington, DC 20593-0001 | 1 |
| 7. LT Patrick McGillvray 4725 Harlequin Way Chesapeake, VA 23321 | 1 |