

te technical note techn

Operational Test and Evaluation (OT&E) Operational Test Plan for Type V/VI Fixed Ground Antenna Radome (FGAR)

Leonard H. Baker

DISTRIBUTION STATEMENT A

Approved for public release
Distribution Unlimited

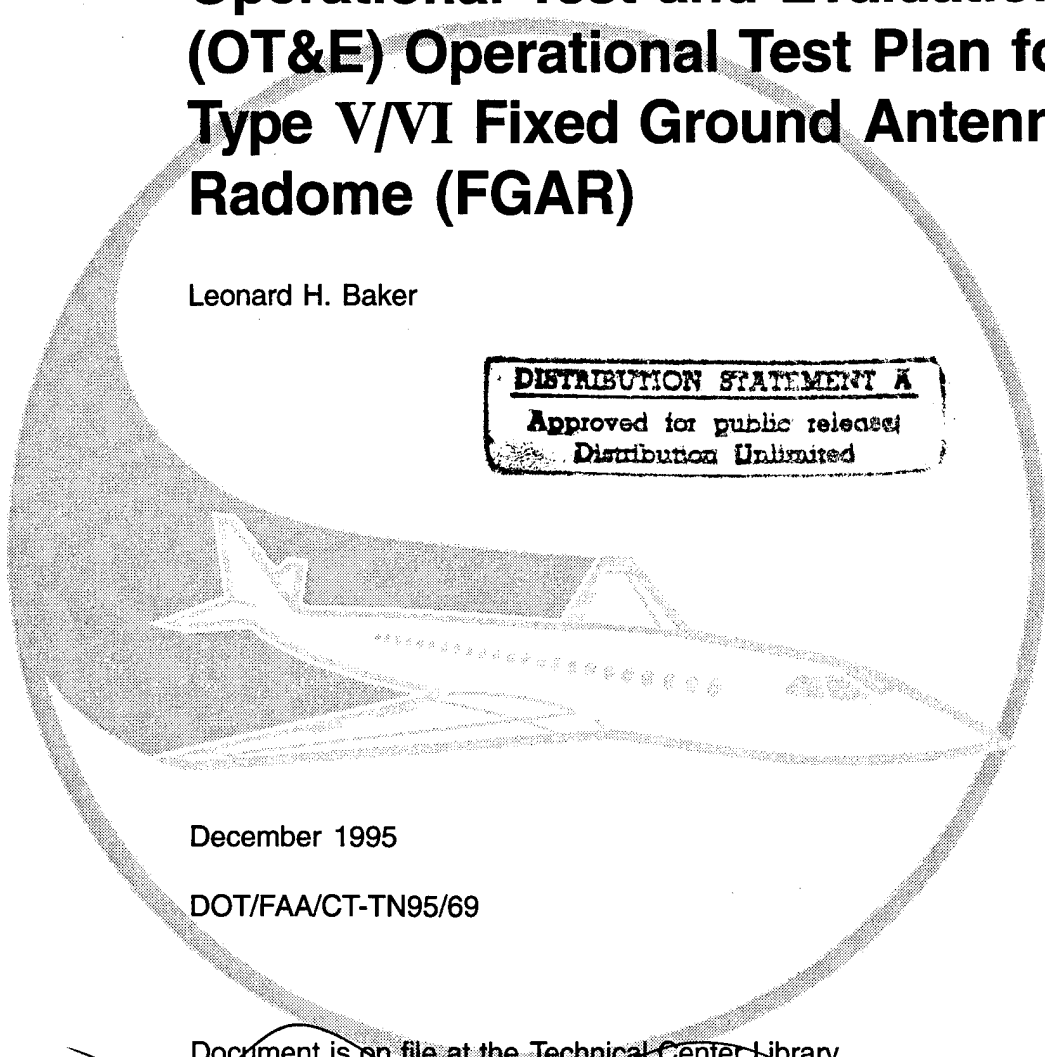

December 1995

DOT/FAA/CT-TN95/69

Document is on file at the Technical Center Library,
Atlantic City International Airport, NJ 08405



U.S. Department of Transportation
Federal Aviation Administration

Technical Center
Atlantic City Airport, NJ 08405

DIG QUALITY INSPECTED 1

19960228 056

NOTICE

This document is disseminated under the sponsorship of the U.S. Department of Transportation in the interest of information exchange. The United States Government assumes no liability for the contents or use thereof.

The United States Government does not endorse products or manufacturers. Trade or manufacturers' names appear herein solely because they are considered essential to the objective of this report.

1. Report No. DOT/FAA/CT-TN95/69		2. Government Accession No.		3. Recipient's Catalog No.	
4. Title and Subtitle OPERATIONAL TEST AND EVALUATION (OT&E) OPERATIONAL TEST PLAN FOR TYPE V/VI FIXED GROUND ANTENNA RADOME (FGAR)				5. Report Date December 1995	
				6. Performing Organization Code	
7. Author(s) Leonard H. Baker, ACT-310B; Harold G. Sedgwick, Raytheon				8. Performing Organization Report No. DOT/FAA/CT-TN95/69	
				10. Work Unit No. (TRAIS)	
9. Performing Organization Name and Address U.S. Department of Transportation Federal Aviation Administration Technical Center Atlantic City International Airport, NJ 08405				11. Contract or Grant No.	
				13. Type of Report and Period Covered Technical Note	
12. Sponsoring Agency Name and Address U.S. Department of Transportation Federal Aviation Administration Technical Center Atlantic City International Airport, NJ 08405				14. Sponsoring Agency Code	
				15. Supplementary Notes	
16. Abstract <p>The Federal Aviation Administration (FAA) Operational Test and Evaluation (OT&E) Operational Test Plan for Type V/VI Fixed Ground Antenna Radome (FGAR) is prepared by the Associate Program Manager for Test (APMT). It defines the overall planning, test activities, and coordination associated with OT&E Operational testing required to ensure the project meets the requirements of the specification, and the system and subsystem requirements allocated to the project.</p> <p>The purpose of the FGAR project is to provide new, larger radomes for en route surveillance radars and for Beacon Only Sites (BOS) that require Mode Select Beacon System (Mode S) installations. The FGARs will provide an environmental enclosure for a variety of single or dual-faced monopulse beacon phased array and en route surveillance radar antennas.</p> <p>The Type V/VI FGAR is specially designed to be mounted on an Air Route Surveillance Radar (ARSR)-3 antenna tower. The first Type V/VI FGAR will be installed at the Newport, Attala County, Mississippi (MS) ARSR-3 En Route Radar Facility.</p>					
17. Key Words Fixed Ground Antenna Radome (FGAR) Test and Evaluation (T&E) Operational Test and Evaluation (OT&E)			18. Distribution Statement Document is on file at the Technical Center Library, Atlantic City International Airport, NJ 08405		
19. Security Classif. (of this report) Unclassified		20. Security Classif. (of this page) Unclassified		21. No. of Pages 39	22. Price

TABLE OF CONTENTS

	Page
EXECUTIVE SUMMARY	v
1. INTRODUCTION	1
1.1 Background	1
1.2 Purpose	2
1.3 Scope	2
2. REFERENCE DOCUMENTS	2
2.1 FAA Orders	2
2.2 FAA Standards	2
2.3 FAA Specifications	2
2.4 NAS Documents	3
2.5 Other FAA Documents	3
3. SYSTEM DESCRIPTION	5
3.1 System Overview	5
3.2 Interfaces Overview	5
4. TEST PROGRAM DESCRIPTION	8
4.1 Approach and Concept	8
4.2 Test Environment	9
4.3 Test and Analysis Tools	9
4.4 Test and/or Evaluation Descriptions	9
5. TEST MANAGEMENT	9
5.1 Test Management Organization	9
5.2 Training	11
5.3 System Configuration Management	11
5.4 Test Readiness Criteria	11
5.5 Test Execution	11
5.6 Test Completion Criteria	12
5.7 Test Reports	12
5.8 Test Discrepancy Reports (TDR)	15
5.9 Test Schedule	15
5.10 Personnel Resource Requirements	15
6. ACRONYMS	17
APPENDIX A	Test Descriptions
APPENDIX B	Data Analysis Programs
APPENDIX C	Test Verification Requirements Traceability Matrix (TVRTM)

LIST OF ILLUSTRATIONS

Figure		Page
2-1	Reference Documents	4
3.2.2-1	Type V/VI FGAR Interfaces Block Diagram	7
5.7-1	Test Document and Report Flow	13
5.9-1	Type V/VI FGAR OT&E Operational Test Schedule	16

LIST OF TABLES

Table		Page
5.7-1	Test Report Matrix	14

EXECUTIVE SUMMARY

This test plan describes the Type V/VI Fixed Ground Antenna Radome (FGAR) Operational Test and Evaluation (OT&E) Operational testing required by Order 1810.4B, FAA National Airspace System (NAS) Policy. This plan provides the details not identified in the Federal Aviation Administration (FAA) Test and Evaluation Master Plan (TEMP) for Fixed Ground Antenna Radome (FGAR), report DOT/FAA/CT-TN93/17. There are no NAS requirements for the FGAR defined in either the NAS-SS-1000 or the NAS-DD-1000E. The plan is designed to determine the effect, if any, on the Air Route Surveillance Radar (ARSR)-3 primary and secondary (beacon) radar antenna patterns.

There are three distinct types of FGARs being procured: they are Types I/III, II, and V/VI, which vary principally in size. Extensive OT&E Integration and OT&E Operational testing has been performed at the first two Type I/III FGAR First Article sites. OT&E Operational testing was performed on the Type II FGAR at three sites, each with a different system/antenna configuration. This test plan covers follow-on testing of the Type V/VI FGAR.

The First Article Type V/VI radome will be installed at the Newport, Attala County, Mississippi (MS) ARSR-3 En Radar Facility (QNM) in February 1996. Electromagnetic performance test data will be collected at the Memphis (ZME) and Houston (ZHU) Air Route Traffic Control Centers (ARTCC) by their HOST Computer Systems (HCS). Airway Facilities (AF) specialists at the Memphis (ZME) and Houston (ZHU) ARTCCs will use the Quick Analysis of Radar Sites (QARS); Beacon False Target Analysis (BFTA); Range, Azimuth, Radar Reinforced Evaluator (RARRE); and Common Digitizer Data Reduction (COMDIG) programs to analyze the data. (The Houston ARTCC [ZHU] does not receive data from the Newport ARSR-3 En Route Radar Facility [QNM] at the present time.)

Baseline data will be collected with the original radome installed. Similar data will be collected after the FGAR is installed. The data will be analyzed to determine if the ARSR-3 primary and secondary (beacon) radar antenna patterns have changed.

1. INTRODUCTION.

1.1 BACKGROUND.

The Federal Aviation Administration's (FAA) program to implement the En Route Mode Select Beacon System (Mode S) project resulted in a requirement to replace existing radomes and to install them at sites without a radome. The existing radomes are not physically large enough to accommodate the new Mode S monopulse back-to-back antennas. Facilities that will receive the Fixed Ground Antenna Radomes (FGAR) include: FAA Air Route Surveillance Radar (ARSR) sites, military type long-range surveillance (AN/FPS) radar sites, and Beacon Only Sites (BOS). FGARs will also be procured for Mode S en route facilities presently without radomes. There are three distinct types of FGARs being procured: they are Types I/III, II, and V/VI.

The FAA awarded the FGAR contract to the Electronic Space Systems Corporation (ESSCO) September 30, 1993. FAA-E-2773b, Specification for Fixed Ground Antenna Radome (Mode S Compatible), establishes the requirements for performance, design, production, and acceptance of a state-of-the-art radome which provides environmental protection for sophisticated L-band antenna systems. The contract provides for a turnkey installation. There are no FGAR National Airspace System (NAS) requirements defined in NAS-SS-1000, NAS System Specification, or NAS-DD-1000E, National Air Space Level I Design Document.

The contractor shall conduct a Test and Evaluation (T&E) program in accordance with FAA-E-2773b and the Statement Of Work (SOW). First Article testing will be conducted by the contractor and witnessed by the FAA. The contractor shall conduct factory acceptance testing. The contractor will deliver and install the first three Type I/III, and the first Type II and Type V/VI production FGARs as First Articles. The contractor shall complete First Article testing at the site to verify those contract requirements not verifiable at the factory. The contractor shall conduct Site Acceptance Tests (SAT). The Contract Acceptance Inspection (CAI) shall occur after the contractor successfully completes the SAT. The CAI is the final acceptance of the turnkey installation by the Government from the contractor.

The FAA Technical Center's Communications/Navigation/Surveillance Engineering and Test Division, ACT-300, has conducted extensive Operational Test and Evaluation (OT&E) Integration and Operational testing on the first two Type I FGARs: at the FAA Technical Center's Elwood, New Jersey (NJ) En Route Beacon Test Facility (ERBTF) and the Northwest Mountain Region's Trinidad En Route Radar Facility (TAD), Colorado (CO). In addition, OT&E Operational testing was performed on the First Article Type II FGAR and at two additional sites with different system/antenna configurations. OT&E Integration and Operational testing is designed to ensure the FGAR meets the design requirements. The purpose of the OT&E program is to ensure the operational effectiveness and suitability of the FGAR will meet the user's requirements.

Type V/VI OT&E Operational First Article testing will be performed at the Newport, Attala County, Mississippi (MS) ARSR-3 En Route Radar Facility (QNM) testing will involve collecting electromagnetic performance data at the Memphis (ZME) and Houston (ZHU) Air Route Traffic Control Centers (ARTCC). (The Houston ARTCC [ZHU] is not presently receiving data from the Newport ARSR-3 En Route Radar Facility [QNM].)

1.2 PURPOSE.

The purpose of this document is to define the overall planning, testing activities, and coordination associated with OT&E Operational testing of the Type V/VI FGAR. The testing will be performed in accordance with Order 1810.4B, FAA NAS Test and Evaluation Policy, and NAS-MD-110, Test and Evaluation (T&E) Terms and Definitions for the National Airspace System.

OT&E Operational testing will ensure the Type V/VI FGAR meets the requirements defined in Order 1810.4B. It will focus on determining to what degree the FGAR meets, exceeds, or degrades the operational characteristics of the enclosed ARSR-3 primary and secondary (beacon) radar antenna patterns.

1.3 SCOPE.

This test plan defines the:

- a. Requirements to be verified.
- b. Test objectives.
- c. Criteria for the successful completion of each test.
- d. Configuration(s) to be used during testing.
- e. Scope of the testing to be accomplished.
- f. Resources and activities to be coordinated in preparation for, and in support of the testing.
- g. Development of detailed test procedures to perform the testing.

2. REFERENCE DOCUMENTS.

A list of applicable documentation and reference materials that relate to the contents of this plan are provided in the following paragraphs. The hierarchical dependency of the documents used in developing this test plan are shown in figure 2-1.

2.1 FAA ORDERS.

Order 1810.4B	FAA NAS Test and Evaluation Policy
Order 6100.1C	Maintenance of NAS En Route Stage A Air Traffic Control System
Order 6300.12	Project Implementation Plan (PIP) Fixed Ground Antenna Radome (FGAR) Including Tower Retrofit Modification

2.2 FAA STANDARDS.

FAA-STD-024b	Content and Format Requirements for the Preparation of Test and Evaluation Documentation
--------------	------------------------------------------------------------------------------------------

2.3 FAA SPECIFICATIONS.

FAA-E-2773b	Specification for Fixed Ground Antenna Radome (Mode S Compatible)
-------------	-------------------------------------------------------------------

2.4 NAS DOCUMENTS.

NAS-MD-110 Test and Evaluation (T&E) Terms and Definitions for the
National Airspace System

2.5 OTHER FAA DOCUMENTS.

DTFA01-93-C-00075 Fixed Ground Antenna Radome (FGAR) Contract

DOT/FAA/CT-TN93/17 Fixed Ground Antenna Radome (FGAR) Master Test and
Evaluation Plan (TEMP)

DOT/FAA/CT-TN95/23 Fixed Ground Antenna Radome (FGAR) Type I/III OT&E
Integration and OT&E Operational Final Test Report

FAA-4306B-8H User's Manual - Common Digitizer Data Reduction (COMDIG)
Program

FAA-4306F-3H User's Manual - Common Digitizer Record (CD RECORD)
Program

FAA-4306M-6H User's Manual - Range, Azimuth, Radar Reinforced
Evaluator (RARRE) Program

FAA-4306N-6H User's Manual - Quick Analysis of Radar Sites (QARS)
Program

FAA-4306P-9H User's Manual - Beacon False Target Analysis (BFTA)
Program

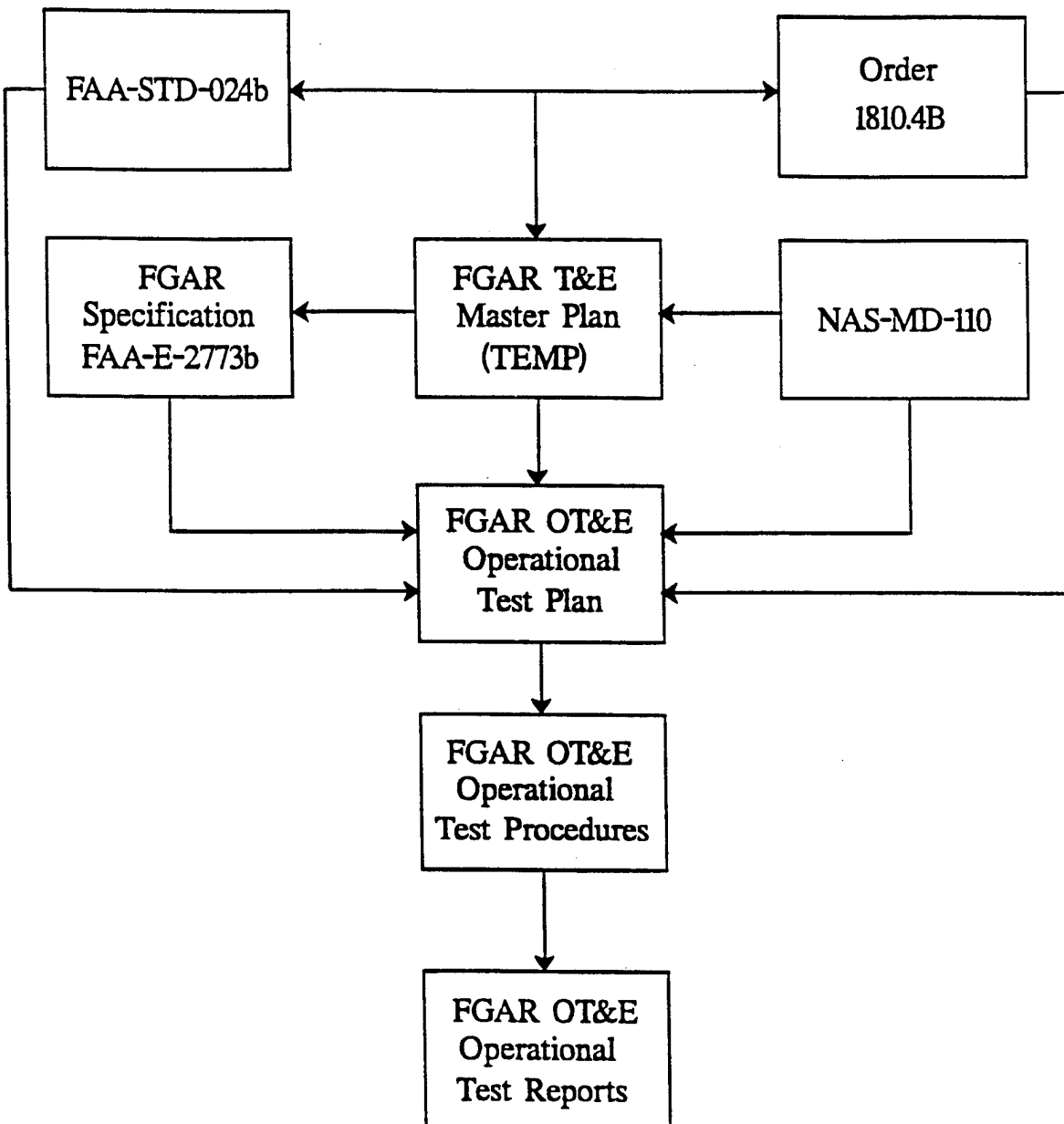

FIGURE 2-1. REFERENCE DOCUMENTS

3. SYSTEM DESCRIPTION.

3.1 SYSTEM OVERVIEW.

The FGAR supplies optimal protection of the antenna(s) from the outside environment while providing minimal degradation to the electromagnetic performance characteristics of the enclosed antenna(s). The hardware required for installation, i.e., cables, wiring, support equipment, radome mounted/ supported equipment, radome base ring (Type II only), and spare parts are part of the FGAR procurement. There are five types of radomes (no Type IV radomes are being procured). They are the following:

a. Type I Radome.

This type of radome will provide an environmental enclosure for a collocated L-band surveillance radar reflector and top-mounted dual-faced L-band beacon phased array antenna. The radome will be capable of withstanding wind velocities of 150 miles per hour (MPH). They will have an inside diameter of 59 feet at their widest point, and will fit a base-ring diameter equal to the present CW-396A radome. The enclosed antennas will rotate at a speed of either 5 or 6 revolutions per minute (RPM).

b. Type II Radome.

This type of radome will provide an environmental enclosure for a dual-faced L-band beacon phased array antenna consisting of two identical rectangular back-to-back antennas approximately 6 feet high by 27 feet wide, rotating at speeds up to 5 RPM. The radome will be capable of withstanding wind velocities of 150 MPH and have an inside diameter of 35 feet at its widest point. It will fit the standard beacon-only antenna platform.

c. Type III Radome.

This type of radome will be identical to the Type I in all respects, except that it will be capable of withstanding wind velocities of 100 MPH maximum.

d. Type V Radome.

This type of radome will provide an environmental enclosure for a collocated L-band surveillance radar reflector and top-mounted dual-faced L-band beacon phased array antenna. The radome will be capable of withstanding wind velocities of 150 MPH. They will have an inside diameter of 57.5 feet at their widest point, and will fit a base-ring diameter equal to the present ARSR-3 radome.

e. Type VI Radome.

This type of radome will be identical to the Type V in all respects, except that it will be capable of withstanding wind velocities of 100 MPH maximum.

3.2 INTERFACES OVERVIEW.

3.2.1 Mechanical Interface.

a. The Type I/III and V/VI FGARs interface mechanically with the existing antenna tower radome base ring.

b. The Type II FGAR radome base ring is part of the procurement and interfaces with the antenna tower.

3.2.2 Electrical Interface.

The FGAR interfaces electrically with the following facility systems:

- a. Electrical system.
- b. Lightning protection system.
- c. Remote Maintenance Monitoring System (RMMS)/Environmental Remote Monitoring Subsystem (ERMS).
- d. Transient protection.

These interfaces will be verified during the contractor's SAT and will not be repeated during the FAA's OT&E.

A block diagram of the Type V/VI interfaces are shown in figure 3.2.2-1.

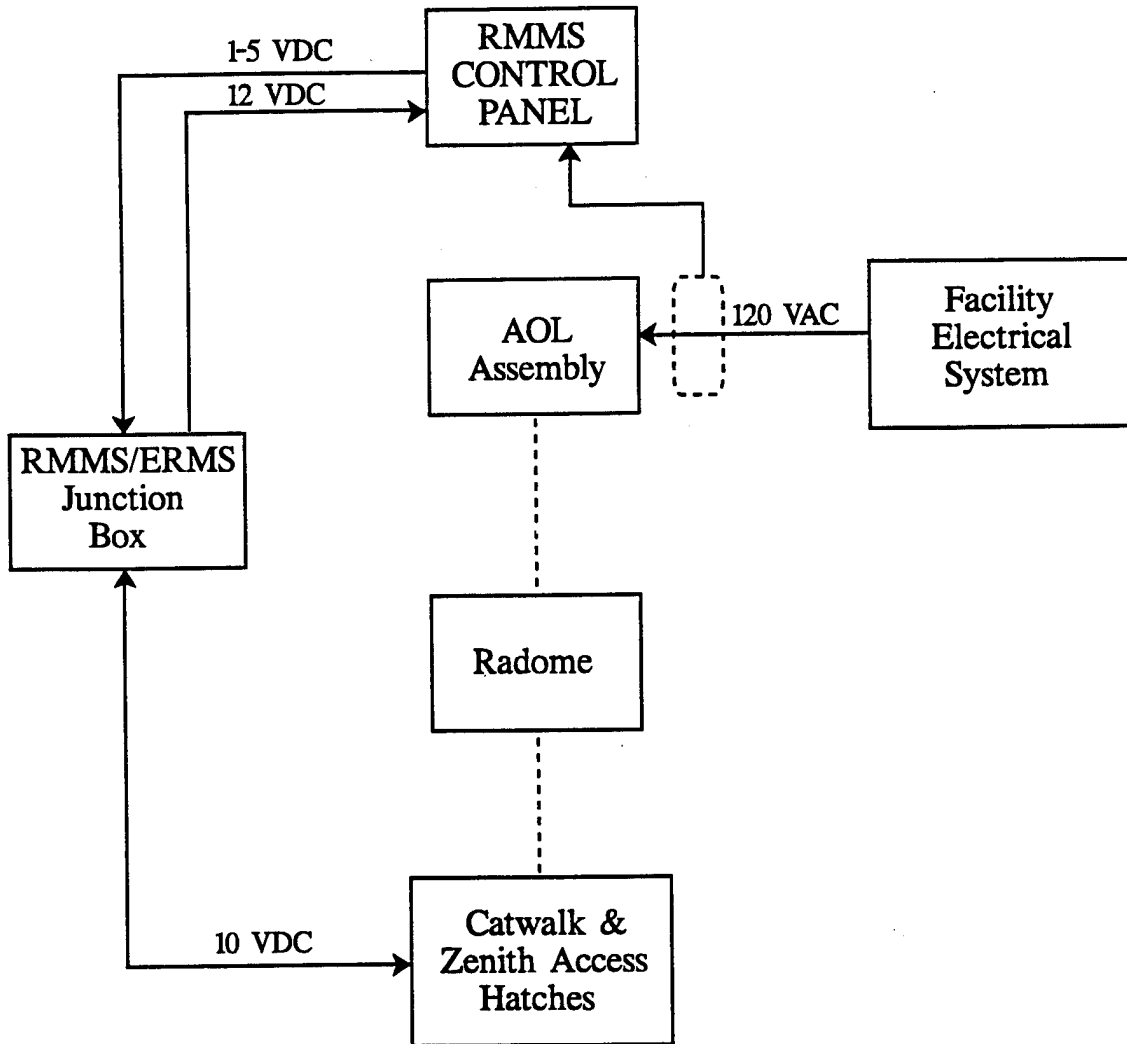

LEGEND

- Mechanical
- Electrical
- () Inductive Coupling

FIGURE 3.2.2-1. TYPE V/VI FGAR INTERFACES BLOCK DIAGRAM

4. TEST PROGRAM DESCRIPTION.

4.1 APPROACH AND CONCEPT.

OT&E Operational testing will be accomplished at the Newport ARSR-3 En Route Radar Facility (QNM), which is the Type V/VI FGAR First Article site. The OT&E Operational testing will be limited to electromagnetic performance testing using "live" aircraft (targets of opportunity) reply data collected at the Memphis (ZME) and Houston (ZHU) ARTCCs. The ARTCCs will collect and analyze primary and secondary (beacon) radar data received from the Newport ARSR-3 En Route Radar Facility (QNM) using their HOST Computer System (HCS) and the QARS, BFTA, COMDIG, and RARRE programs.

4.1.1 Evaluation Approach.

The OT&E Operational testing approach is to verify the FGAR's Measures of Effectiveness (MOE) and Measures of Suitability (MOS) separately.

a. Primary and secondary (beacon) radar data will be collected using "live" aircraft (targets of opportunity) to determine the electromagnetic performance MOE and MOS.

b. The TEMPs Test Verification Requirements Traceability Matrix (TVRTM) defines the verification methods.

4.1.2 Critical Operational Issues (COI)/Test Requirements Summary.

The COI is: there is no degradation to the primary or secondary (beacon) radar aircraft positional accuracy.

4.1.3 Minimum Acceptable Operational Requirements (MAOR).

The MAOR are:

a. There is no degradation in the electromagnetic performance of the primary or secondary (beacon) radar antenna patterns.

b. There is no degradation in the azimuth pointing accuracy.

4.1.4 Activities Leading to Test.

The electromagnetic performance tests are divided into two phases. Phase 1 will be completed with the original radome installed. Phase 2 will be completed after the contractor has:

a. Completed the installation of the FGAR.

b. Removed any scaffolding, cranes, etc., required for its installation.

c. Completed the First Article Design Qualification Test (DQT).

d. Completed the SAT.

e. Completed the CAI.

4.2 TEST ENVIRONMENT.

OT&E Operational testing will be accomplished using primary and secondary (beacon) radar data from the Newport ARSR-3 En Route Radar Facility (QNM). The Newport ARSR-3 En Route Radar Facility (QNM) is an operational facility, supplying data to the Memphis (ZME) and Houston (ZHU) ARTCCs. (The Houston ARTCC [ZHU] is not presently receiving data from the Newport ARSR-3 En Route Radar Facility [QNM].)

4.2.1 Test Locations.

OT&E Operational testing will be accomplished at the Memphis (ZME) and Houston (ZHU) ARTCCs. They will use their HCS and the QARS, BFTA, COMDIG, and RARRE programs to analyze the electromagnetic performance of the primary and secondary (beacon) radar data received from the Newport ARSR-3 En Route Radar Facility (QNM).

4.3 TEST AND ANALYSIS TOOLS.

4.3.1 Data Collection.

Data will be collected by the Memphis (ZME) ARTCC using their HCS and the CD RECORD and QARS programs.

4.3.2 Data Analysis.

The QARS program will provide statistical "live" aircraft tracking data that will be analyzed to determine if any degradation of NAS has occurred due to the installation of the FGAR.

The BFTA, COMDIG, and RARRE programs will provide detailed information about the "live" aircraft tracking data.

4.4 TEST AND/OR EVALUATION DESCRIPTIONS.

The tests to be conducted are contained in appendix A. Each test is uniquely identified by a test number and contains sufficient information to plan for the test activity.

5. TEST MANAGEMENT.

5.1 TEST MANAGEMENT ORGANIZATION.

The FGAR test management team is responsible for ensuring all requirements are verified during OT&E Operational testing. The test management team is composed of representatives from AND-440 and ACT-310.

The FGAR test management team has the responsibility to direct, control, and monitor all activities relative to FGAR OT&E Operational testing. Specifically these responsibilities include:

- a. Implementing a test program that is consistent with the requirements of Order 1810.4B.
- b. Reviewing and providing concurrence/nonconcurrency with all test plans, procedures, and related T&E documentation.
- c. Distribution of T&E activity related documents to all participating organizations for review.

d. Assigning roles and responsibilities to the OT&E Operational test support group.

e. Directing and conducting OT&E Operational testing.

5.1.1 Roles and Responsibilities.

The FGAR test management team consists of personnel who are knowledgeable in the specific technical areas. The role of this team is to develop test requirements, plans, procedures, and other support tools. The composition and duties of the team are listed below.

<u>Organization</u>	<u>Primary Roles/Functions</u>
AND-440	<u>Program Manager (PM)</u> Provides ultimate authority and direction for test operations.
AND-440	<u>Associate Program Manager for Engineering (APME)</u> Provides engineering support to the PM.
ACT-310B	<u>Associate Program Manager for Test (APMT)</u> Appointed by the Technical Center. Manages test program for the PM, prepares the OT&E Operational Test Plan and Procedures, conducts OT&E Operational testing, prepares test reports, coordinates all test activities, determines test requirements, and provides coordination and direction for implementing the OT&E Operational Test Plan.

5.1.2 Other Participating Organizations.

The FGAR test support team will be supplemented by members of the following organizations:

<u>Organization</u>	<u>Primary Roles/Functions</u>
Houston ARTCC (ZHU), Gulf Coast Systems Management Office (SMO)	Provides the computers, software, and trained personnel to run the QARS, BFTA, COMDIG, and RARRE programs, on data received from the Newport ARSR-3 En Route Radar Facility (QNM), and to analyze the results.
Memphis ARTCC (ZME), Memphis SMO	Provides the computers, software, and trained personnel to run the QARS, BFTA, COMDIG, and RARRE programs, on data received from the Newport ARSR-3 En Route Radar Facility (QNM), and to analyze the results.

5.1.3 Test Conduct Team.

A Test Director (TD) will be assigned for the Type V/VI FGAR OT&E Operational test program.

5.2 TRAINING.

The test team members do not require any special training to conduct the tests. Personnel who are fully qualified in their present positions, e.g., electronic engineers and technicians, computer operators, etc., will be used for conducting the tests. The analysis of data recorded at the Memphis ARTCC (ZME) will be performed by Technical Support Staff (TSS) personnel, who are familiar with the interpretation of the statistical outputs provided by the software analysis programs.

5.3 SYSTEM CONFIGURATION MANAGEMENT.

System Configuration Management (SCM) is the responsibility of the Newport ARSR-3 En Radar Facility (QNM) manager.

5.3.1 Testbed Configuration.

The Newport ARSR-3 En Route Radar Facility (QNM) has the following systems installed:

- a. ARSR-3
- b. Air Traffic Control Beacon Interrogator (ATCBI)-5

5.4 TEST READINESS CRITERIA.

The electromagnetic performance testing is divided into two phases and will be performed in conjunction with the FGAR installation. This testing will ensure the FGAR does not degrade the electromagnetic performance of the ARSR-3 primary or secondary (beacon) radar antenna patterns. The phases are:

a. Phase 1.

With the original radome installed.

b. Phase 2.

After the installation of the FGAR is completed and the contractor has:

1. Removed any scaffolding, cranes, etc., required for its installation.
2. Completed First Article DQT.
3. Completed the SAT.
4. Completed the CAI.

5.5 TEST EXECUTION.

The testing will be performed at the Memphis (ZME) and Houston (ZHU) ARTCCs. The following sections describe the pretest and post-test reviews.

5.5.1 Pretest Review.

The test will be performed at a time determined by the individual facilities. Therefore, no formal pretest review will be conducted.

5.5.2 Post-Test Review.

The test will be performed at a time determined by the individual facilities. Therefore, no formal post-test review will be conducted.

5.6 TEST COMPLETION CRITERIA.

The individual test completion criteria are contained in the test descriptions (see appendix A).

5.7 TEST REPORTS.

A description of the reports required for reporting the OT&E Operational test activities are presented in the following paragraphs. Figure 5.7-1 illustrates the sequence in which the test documents and reports are prepared. A description of the reports and when they are prepared is shown in table 5.7-1.

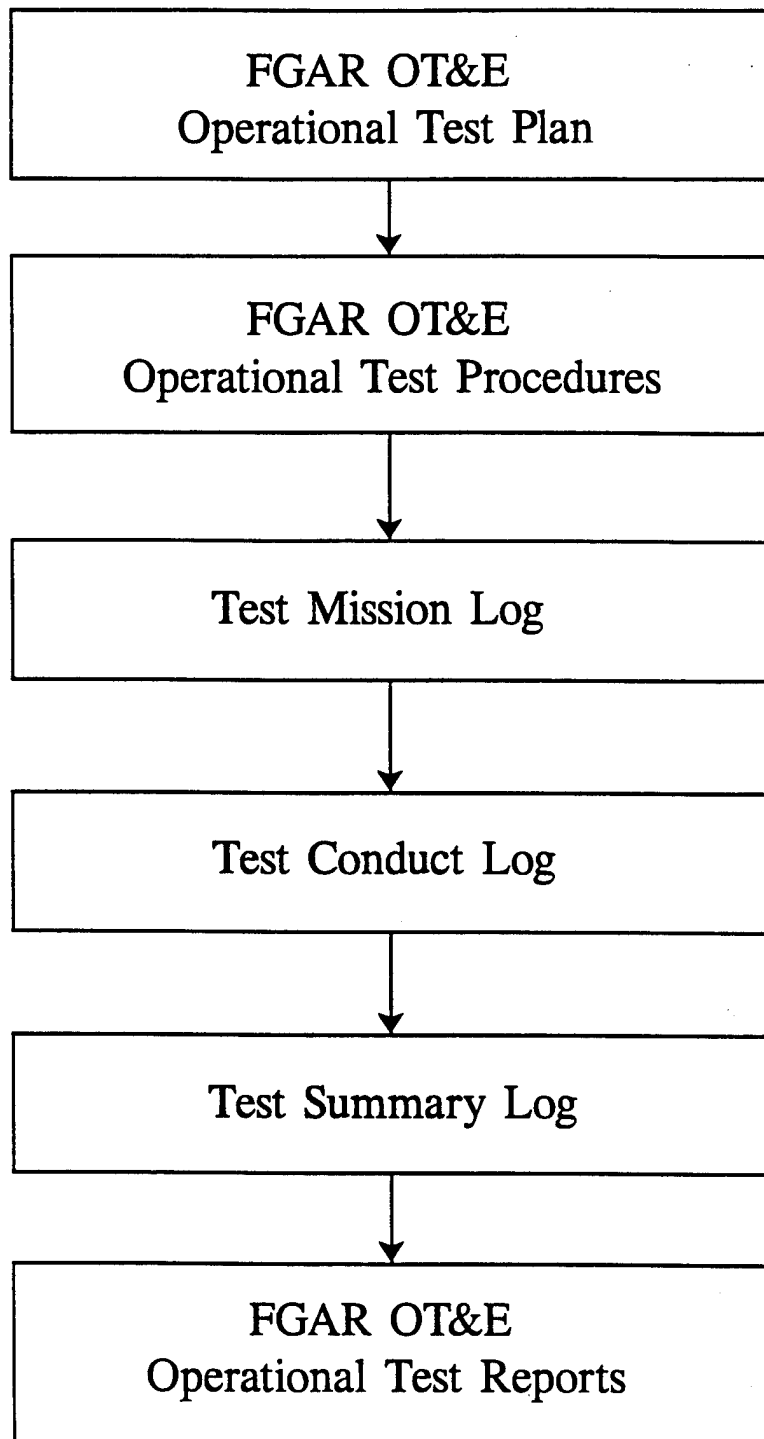

FIGURE 5.7-1. TEST DOCUMENT AND REPORT FLOW

TABLE 5.7-1 TEST REPORT MATRIX

Report	Required Completion
Test Mission Log	Prepared by TD
Test Conduct Log	Prepared by TD
Test Summary Log	Prepared by TD
Test Discrepancy Report (TDR)	Prepared by the TD, if required
OT&E Operational Test Reports:	
1. Quick Look Report	Fifteen calendar days after completion of OT&E Operational testing
2. Preliminary OT&E Operational Test Report	Thirty calendar days after the Quick Look Report
3. Final OT&E Operational Test Report	Thirty calendar days after the Preliminary OT&E Operational Test Report is submitted

5.7.1 Test Mission Log.

The Test Mission Log is completed by the TD, based on information received from the facility personnel. The log will contain any open items, e.g., deviations from the test procedures, required regression testing, etc.; test objectives; hardware configuration(s); and a list of the test team members and their assignments.

5.7.2 Test Conduct Log.

The Test Conduct Log is completed by the TD, based on information received from the facility personnel. The log contains a record of specific events, measurements, etc., problems encountered, anomalies, etc.

5.7.3 Test Summary Log.

The Test Summary Log is completed by the TD, based on information received from the facility personnel. The log contains a summary of the test conduct and a preliminary assessment of the results.

5.7.4 Test Reports.

The test reports trace the test results to relevant issues and the operational test requirements. The reports describe anomalous test results, highlight any outstanding or unresolved problems, and identify options for their resolution. There are three test reports:

- a. Quick Look Report
- b. Preliminary OT&E Operational Test Report
- c. Final OT&E Operational Test Report

5.8 TEST DISCREPANCY REPORTS (TDR).

TDRs are prepared, if required, by the TD. These reports document any anomalies or deficiencies encountered during the conduct of a test. They describe in detail problems, failures, etc., encountered during the test.

5.9 TEST SCHEDULE.

The FGAR OT&E test schedule flows from the FGAR contract and TEMP requirements. The operational testing timeframes are based on the delivery and acceptance dates. The Type V/VI FGAR schedule is shown in figure 5.9-1.

5.9.1 Planning Considerations and Limitations.

If there is a slippage in the Type V/VI FGAR schedule, the test dates will be adjusted accordingly.

5.10 PERSONNEL RESOURCE REQUIREMENTS.

The personnel required for testing are described below.

- a. Memphis ARTCC (ZME), Memphis SMO, TSS personnel, and HCS operators.
- b. Houston ARTCC (ZHU), Gulf Coast SMO, TSS personnel, and HCS operators.

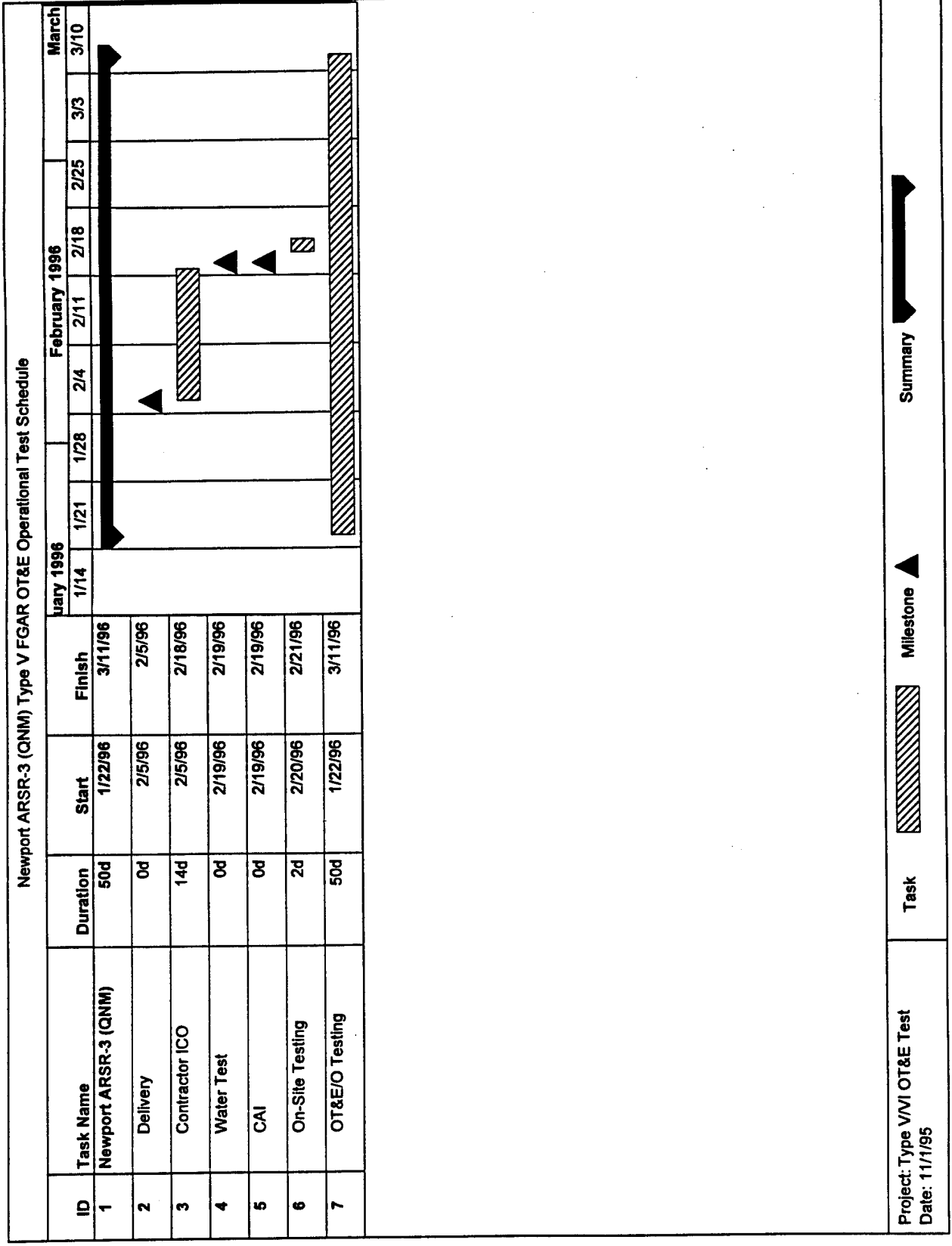

FIGURE 5.9-1. TYPE V/VI FGAR OT&E OPERATIONAL TEST SCHEDULE

6. ACRONYMS.

ACP	Azimuth Change Pulse (QARS program)
AF	Airway Facilities
ALT	Altitude (QARS program)
AN/FPS	Army-Navy/Fixed Ground Radar Search (military designation)
AOL	Aircraft Obstruction Light(s)
APME	Associate Program Manager for Engineering
APMT	Associate Program Manager for Test
ARSR	Air Route Surveillance Radar
ARTCC	Air Route Traffic Control Center
ASPLT	Azimuth Split (QARS program)
ATCBI	Air Traffic Control Beacon Interrogator
ATCRBS	Air Traffic Control Radar Beacon System
AZ	Azimuth (QARS program)
BCN	Beacon (QARS program)
BFTA	Beacon False Target Analysis (computer program)
BLIP	Blip/Scan Ratio (QARS program)
BOS	Beacon Only Site
C	Critical
CAI	Contract Acceptance Inspection
CD	Common Digitizer
CD RECORD	Common Digitizer Record (computer program)
CO	Colorado
COI	Critical Operational Issues
COLL	Collimation (QARS program)
COMDIG	Common Digitizer Data Reduction (computer program)
CW	Radomes (military designation)
DEV	Deviation (QARS program)
DQT	Design Qualification Test
DRG	Data Receiver Group
ERBTF	En Route Beacon Test Facility

ERMS	Environmental Remote Monitoring Subsystem
ESSCO	Electronic Space Systems Corporation (company name)
FAA	Federal Aviation Administration
FALSE-BCN	False Beacon (QARS program)
FGAR	Fixed Ground Antenna Radome
HCS	HOST Computer System
HOST	Air Traffic Control HOST Computer System (not an acronym)
I	Integration
ICO	Installation and Checkout
ID	Identification
M3REL	Mode 3/A Reliability (QARS program)
M3VAL	Mode 3/A Validity (QARS program)
MAOR	Minimum Acceptable Operational Requirements
MCREL	Mode C Reliability (QARS program)
MCVAL	Mode C Validity (QARS program)
MS	Mississippi
Mode S	Mode Select Beacon System
MOE	Measures Of Effectiveness
MOS	Measurers Of Suitability
MPH	Miles Per Hour
MTI	Moving Target Indicator (QARS program)
NAS	National Airspace System
NC	Noncritical
NJ	New Jersey
NML	Normal (QARS program)
NO.	Number
O	Operational
OT&E	Operational Test and Evaluation
OT&E/O	Operational Test and Evaluation/Operational
PE	Permanent Echo (QARS program)
PIP	Project Implementation Plan

PM	Program Manager
QARS	Quick Analysis of Radar Sites (computer program)
QNM	Newport ARSR-3 En Route Radar Facility (identifier)
R/R	Radar Reinforced (QARS program)
RAR	Ring-A-Round (QARS program)
RARRE	Range, Azimuth, Radar Reenforced Evaluator (computer program)
REF	Reference
REF	Reflection (QARS program)
RMMS	Remote Maintenance Monitoring System
RPM	Revolutions Per Minute
RSPLT	Range Split (QARS program)
SAT	Site Acceptance Test
SCAN	Blip/Scan Ratio (QARS program)
SCH	Combined MTI and Normal Video (QARS program)
SCM	System Configuration Management
SMO	Systems Management Office
SOW	Statement of Work
T&E	Test and Evaluation
TAD	Trinidad En Route Radar Facility (identifier)
TD	Test Director
TDR	Test Discrepancy Report
TEMP	Test and Evaluation Master Plan
TSS	Technical Support Staff
TVRTM	Test Verification Requirements Traceability Matrix
VAC	Volts Alternating Current
VDC	Volts Direct Current
ZER	Code Zero Percentage (QARS program)
ZHU	Houston Air Route Traffic Control Center (identifier)
ZME	Memphis Air Route Traffic Control Center (identifier)

APPENDIX A
TEST DESCRIPTIONS

TEST DESCRIPTIONS

1. TEST TITLE.

NPME-1 Memphis ARTCC (ZME)/Newport ARSR-3 (QNM) Quick Analysis of Radar Sites (QARS) Program Test (3.2.1.1)

1.1 TEST OBJECTIVES.

The objective is to determine if there are any differences in the performance characteristics of the Newport ARSR-3 En Route Radar Facility (QNM) primary and secondary (beacon) radar data being received by the ARTCC, after the FGAR is installed.

1.2 TEST CRITERIA.

The performance characteristics of the Newport ARSR-3 En Route Radar Facility (QNM) primary and secondary (beacon) radar data being received by the ARTCC are not degraded by the FGAR. The performance characteristics are those described in appendix B.

1.3 TEST APPROACH.

The Memphis ARTCC (ZME) will run the QARS program on their HCS using primary and secondary (beacon) radar data from the Newport ARSR-3 En Route Radar Facility (QNM). The ARTCCs Airway Facilities (AF) TSS personnel will analyze the data.

Test NPME-1 will be accomplished by test and analysis.

1.4 TEST CONDUCT.

The test will be divided into two phases.

- a. Phase 1 - With the original radome installed.
- b. Phase 2 - After installation of the FGAR is complete and the contractor has completed the:
 1. First Article DQT.
 2. SAT.
 3. CAI.

During both phases, the HCS operators will run the QARS program using the Newport ARSR-3 En Route Radar Facility (QNM) primary and secondary (beacon) radar data and provide a printout of the results to the AF TSS personnel. The TSS personnel will analyze the data and prepare a report.

1.5 EXECUTION TIME.

The test will take approximately 2 hours each time it is run.

2. TEST TITLE.

NPME-2 Memphis ARTCC (ZME)/Newport ARSR-3 (QNM) Beacon False Target Analysis (BFTA) Program Test (3.2.1.1)

2.1 TEST OBJECTIVES.

The objective is to determine if there are any differences in the number and/or types of beacon false targets, i.e., splits, ring-around, reflections, etc., in the Newport ARSR-3 En Route Radar Facility (QNM) beacon data being received by the ARTCC, after the FGAR is installed.

2.2 TEST CRITERIA.

The number and/or types of beacon false targets contained in the Newport ARSR-3 En Route Radar Facility (QNM) beacon data received by the ARTCC did not increase, after installation of the FGAR.

2.3 TEST APPROACH.

The Memphis ARTCC (ZME) will run the BFTA program on their HCS using beacon data from the Newport ARSR-3 En Route Radar Facility (QNM). The ARTCC's AF TSS personnel will analyze the data.

Test NPME-2 will be accomplished by test and analysis.

2.4 TEST CONDUCT.

The test will be divided into two phases.

- a. Phase 1 - With the original radome installed.
- b. Phase 2 - After installation of the FGAR is complete and the contractor has completed the:
 1. First Article DQT.
 2. SAT.
 3. CAI.

During both phases, the HCS operators will run the BFTA program using the Newport ARSR-3 En Route Radar Facility (QNM) beacon data. The TSS personnel will analyze the data and prepare a report.

2.5 EXECUTION TIME.

The test will take approximately 2 hours each time it is run.

3. TEST TITLE.

NPME-3 Memphis ARTCC (ZME)/Newport ARSR-3 (QNM) Common Digitizer Data
Reduction (COMDIG) Program Test (3.2.1.1)

3.1 TEST OBJECTIVES.

The objective is to determine if there are any changes in the position of the primary radar permanent echoes (PE) and/or beacon "parrot(s)," in the Newport ARSR-3 En Route Radar Facility (QNM) data being received by the ARTCC, after the FGAR is installed.

3.2 TEST CRITERIA.

There is no change in the position of the Newport ARSR-3 En Route Radar Facility (QNM) primary radar PEs and/or beacon "parrot(s)" in the data being received by the ARTCC, after the FGAR is installed.

3.3 TEST APPROACH.

The Memphis ARTCC (ZME) will run the COMDIG program on their HCS using primary and secondary (beacon) radar data from the Newport ARSR-3 En Route Radar Facility (QNM). The ARTCC's AF TSS personnel will analyze the data.

Test NPME-3 will be accomplished by test and analysis.

3.4 TEST CONDUCT.

The test will be divided into two phases.

- a. Phase 1 - With the original radome installed.
- b. Phase 2 - After installation of the FGAR is complete and the contractor has completed the:
 1. First Article DQT.
 2. SAT.
 3. CAI.

During both phases, the HCS operators will run the COMDIG program using the Newport ARSR-3 En Route Radar Facility (QNM) primary and secondary (beacon) radar data. The TSS personnel will analyze the data and prepare a report.

3.5 EXECUTION TIME.

The test will take approximately 2 hours each time it is run.

4. TEST TITLE.

NPME-4 Memphis ARTCC (ZME)/Newport ARSR-3 (QNM) Range, Azimuth, Radar
Reinforced Evaluator (RARRE) Program Test (3.2.1.1)

4.1 TEST OBJECTIVE.

The objective is to determine if there are any differences in the overall radar reenforcement percentage, altitude coverage, and/or range coverage in the Newport ARSR-3 En Route Radar Facility (QNM) primary and secondary (beacon) radar data being received by the ARTCC, after the FGAR is installed.

4.2 TEST CRITERIA.

The radar reenforcement percentage, altitude coverage, and range coverage did not decrease, after installation of the FGAR.

4.3 TEST APPROACH.

The Memphis ARTCC (ZME) will run the RARRE program on their HCS using primary and secondary (beacon) radar data from the Newport ARSR-3 En Route Radar Facility (QNM). The ARTCC's AF TSS personnel will analyze the data.

Test NPME-4 will be accomplished by test and analysis.

4.4 TEST CONDUCT.

The test will be divided into two phases.

- a. Phase 1 - With the original radome installed.
- b. Phase 2 - After installation of the FGAR is complete and the contractor has completed the:
 1. First Article DQT.
 2. SAT.
 3. CAI.

During both phases, the HCS operators will run the RARRE program using the Newport ARSR-3 En Route Radar facility (QNM) primary and secondary (beacon) radar data. The TSS personnel will analyze the data and prepare a report.

4.5 EXECUTION TIME.

The test will take approximately 2 hours each time it is run.

5. TEST TITLE.

NPHU-1 Houston ARTCC (ZHU)/Newport ARSR-3 (QNM) Quick Analysis of Radar Sites (QARS) Program Test (3.2.1.1)

5.1 TEST OBJECTIVES.

The objective is to determine if there are any differences in the performance characteristics of the Newport ARSR-3 En Route Radar Facility (QNM) primary and secondary (beacon) radar data being received by the ARTCC, after the FGAR is installed.

5.2 TEST CRITERIA.

The performance characteristics of the Newport ARSR-3 En Route Radar Facility (QNM) primary and secondary (beacon) radar data being received by the ARTCC are not degraded by the FGAR. The performance characteristics are those described in appendix B.

5.3 TEST APPROACH.

The Houston ARTCC (ZHU) will run the QARS program on their HCS using primary and secondary (beacon) radar data from the Newport ARSR-3 En Route Radar Facility (QNM). The ARTCCs AF TSS personnel will analyze the data.

Test NPHU-1 will be accomplished by test and analysis.

5.4 TEST CONDUCT.

The test will be divided into two phases.

- a. Phase 1 - With the original radome installed.
- b. Phase 2 - After installation of the FGAR is complete and the contractor has completed the:
 1. First Article DQT.
 2. SAT.
 3. CAI.

During both phases, the HCS operators will run the QARS program using the Newport ARSR-3 En Route Radar Facility (QNM) primary and secondary (beacon) radar data and provide a printout of the results to the AF TSS personnel. The TSS personnel will analyze the data and prepare a report.

5.5 EXECUTION TIME.

The test will take approximately 2 hours each time it is run.

6. TEST TITLE.

NPHU-2 Houston ARTCC (ZHU)/Newport ARSR-3 (QNM) Beacon False Target Analysis (BFTA) Program Test (3.2.1.1)

6.1 TEST OBJECTIVES.

The objective is to determine if there are any differences in the number and/or types of beacon false targets, i.e., splits, ring-around, reflections, etc., in the Newport ARSR-3 En Route Radar Facility (QNM) beacon data being received by the ARTCC, after the FGAR is installed.

6.2 TEST CRITERIA.

The number and/or types of beacon false targets contained in the Newport ARSR-3 En Route Radar Facility (QNM) beacon data received by the ARTCC did not increase, after installation of the FGAR.

6.3 TEST APPROACH.

The Houston ARTCC (ZHU) will run the BFTA program on their HCS using beacon data from the Newport ARSR-3 En Route Radar Facility (QNM). The ARTCC's AF TSS personnel will analyze the data.

Test NPHU-2 will be accomplished by test and analysis.

6.4 TEST CONDUCT.

The test will be divided into two phases.

- a. Phase 1 - With the original radome installed.
- b. Phase 2 - After installation of the FGAR is complete and the contractor has completed the:
 1. First Article DQT.
 2. SAT.
 3. CAI.

During both phases, the HCS operators will run the BFTA program using the Newport ARSR-3 En Route Radar Facility (QNM) beacon data. The TSS personnel will analyze the data and prepare a report.

6.5 EXECUTION TIME.

The test will take approximately 2 hours each time it is run.

7. TEST TITLE.

NPHU-3 Houston ARTCC (ZHU)/Newport ARSR-3 (QNM) Common Digitizer Data Reduction (COMDIG) Program Test (3.2.1.1)

7.1 TEST OBJECTIVES.

The objective is to determine if there are any changes in the position of the primary radar PEs and/or beacon "parrot(s)," in the Newport ARSR-3 En Route Radar Facility (QNM) data being received by the ARTCC, after the FGAR is installed.

7.2 TEST CRITERIA.

There is no change in the position of the Newport ARSR-3 En Route Radar Facility (QNM) primary radar PEs and/or beacon "parrot(s)" in the data being received by the ARTCC, after the FGAR is installed.

7.3 TEST APPROACH.

The Houston ARTCC (ZHU) will run the COMDIG program on their HCS using primary and secondary (beacon) radar data from the Newport ARSR-3 En Route Radar Facility (QNM). The ARTCC's AF TSS personnel will analyze the data.

Test NPHU-3 will be accomplished by test and analysis.

7.4 TEST CONDUCT.

The test will be divided into two phases.

- a. Phase 1 - With the original radome installed.
- b. Phase 2 - After installation of the FGAR is complete and the contractor has completed the:
 1. First Article DQT.
 2. SAT.
 3. CAI.

During both phases, the HCS operators will run the COMDIG program using the Newport ARSR-3 En Route Radar Facility (QNM) primary and secondary (beacon) radar data. The TSS personnel will analyze the data and prepare a report.

7.5 EXECUTION TIME.

The test will take approximately 2 hours each time it is run.

8. TEST TITLE.

NPHU-4 Houston ARTCC (ZHU)/Newport ARSR-3 (QNM) Range, Azimuth, Radar Reenforced Evaluator (RARRE) Program Test (3.2.1.1)

8.1 TEST OBJECTIVE.

The objective is to determine if there are any differences in the overall radar reenforcement percentage, altitude coverage, and/or range coverage in the Newport ARSR-3 En Route Radar Facility (QNM) primary and secondary (beacon) radar data being received by the ARTCC, after the FGAR is installed.

8.2 TEST CRITERIA.

The radar reenforcement percentage, altitude coverage, and range coverage did not decrease, after installation of the FGAR.

8.3 TEST APPROACH.

The Houston ARTCC (ZHU) will run the RARRE program on their HCS using primary and secondary (beacon) radar data from the Newport ARSR-3 En Route Radar Facility (QNM). The ARTCC's AF TSS personnel will analyze the data.

Test NPHU-4 will be accomplished by test and analysis.

8.4 TEST CONDUCT.

The test will be divided into two phases.

- a. Phase 1 - With the original radome installed.
- b. Phase 2 - After installation of the FGAR is complete and the contractor has completed the:
 1. First Article DQT.
 2. SAT.
 3. CAI.

During both phases, the HCS operators will run the RARRE program using the Newport ARSR-3 En Route Radar facility (QNM) primary and secondary (beacon) radar data. The TSS personnel will analyze the data and prepare a report.

8.5 EXECUTION TIME.

The test will take approximately 2 hours each time it is run.

9. LIST OF TEST TITLES.

NPHU-1 Houston ARTCC (ZHU)/Newport ARSR-3 (QNM) Quick Analysis of Radar Sites (QARS) Program Test

NPHU-2 Houston ARTCC (ZHU)/Newport ARSR-3 (QNM) Beacon False Target Analysis (BFTA) Program Test

NPHU-3 Houston ARTCC (ZHU)/Newport ARSR-3 (QNM) Common Digitizer Data Reduction (COMDIG) Program Test

NPHU-4 Houston ARTCC (ZHU)/Newport ARSR-3 (QNM) Range, Azimuth, Radar Reenforced Evaluator (RARRE) Program Test

NPME-1 Memphis ARTCC (ZME)/Newport ARSR-3 (QNM) Quick Analysis of Radar Sites (QARS) Program Test

NPME-2 Memphis ARTCC (ZME)/Newport ARSR-3 (QNM) Beacon False Target Analysis (BFTA) Program Test

NPME-3 Memphis ARTCC (ZME)/Newport ARSR-3 (QNM) Common Digitizer Data Reduction (COMDIG) Program Test

NPME-4 Memphis ARTCC (ZME)/Newport ARSR-3 (QNM) Range, Azimuth, Radar Reenforced Evaluator (RARRE) Program Test

APPENDIX B
DATA ANALYSIS PROGRAMS

DATA ANALYSIS PROGRAMS

The programs that will be used to analyze the electromagnetic performance of the primary and secondary (beacon) radar data are described below.

1. Beacon False Target Analysis (BFTA) Program.

The BFTA program provides a tool to investigate and evaluate false target problems associated with the Air Traffic Control Radar Beacon System (ATCRBS). The BFTA program retrieves and processes beacon target information relative to all Mode 3/A beacon equipped aircraft detected during one job cycle of the program.

2. Common Digitizer Data Reduction (COMDIG) Program.

The COMDIG program extracts selected types of data from a Common Digitizer Record (CD RECORD) program tape containing various mixtures of six different CD message types received by the HCS and prints the data in prescribed formats.

3. Common Digitizer Record (CD RECORD).

The CD RECORD program provides the capability to record on magnetic tape, Common Digitizer (CD) data as received over the Data Receiver Group (DRG)/HCS interface. The CD RECORD program is run on the HCS.

4. Quick Analysis of Radar Sites (QARS) Program.

The QARS programs is divided into two sections: (1) verification of the radar system interface, and (2) Radar Data Analysis Summary routine which analyzes the primary and secondary (beacon) radar tracks.

a. Radar System Interface Verification.

The following applicable parameters are supplied:

1. Site identification.
2. Beacon percentages.
 - (a) Mode 3/A validation percentage
 - (b) Mode C validation percentage
 - (c) Mode 2 validation percentage
3. Status summary - provides the status of the secondary radar and the CD.

b. Radar Data Analysis Summary.

The following parameters are supplied:

1. Adapted radar site name.
2. Video - The beacon receiver video used for the CD input.
 - (a) Beacon (BCN)
 - (b) Moving Target Indicator (MTI) [primary radar]

- (c) Normal (NML) [primary radar]
- (d) Combined MTI and Normal video (SCH) [primary radar]
- 3. Scans -
 - (a) Beacon - total number of antenna revolutions for the period of time the beacon return was tracked.
 - (b) Surveillance - will vary according to a target's range and elevation (primary radar).
- 4. Blip/Scan - The percentage ratio of the number of times a target was detected (BLIP) to the number of times a target could have been detected (SCAN).
- 5. Radar Reinforced (R/R) - Ratio of number of beacon messages with the reinforced bit set to the total number of beacon messages received.
- 6. Collimation (COLL) - The collimation percentage for NML and MTI video (primary radar).
- 7. Beacon split -
 - (a) Azimuth Split (ASPLT)
 - (b) Range Split (RSPLT)
- 8. False Beacon (FALSE-BCN) -
 - (a) Ring-A-Round (RAR)
 - (b) Reflections (REF)
 - (c) Code Zero Percentage (ZER)
- 9. Code reliability -
 - (a) Mode 3/A reliability percentage (M3REL)
 - (b) Mode 3/A validity (M3VAL)
 - (c) Mode C reliability percentage (MCREL)
 - (d) Mode C validity (MCVAL)
- 10. Range - Beacon track start and stop histories.
- 11. Azimuth (AZ) - Beacon track start and stop histories.
- 12. Altitude (ALT) - Beacon track start and stop histories.
- 13. Deviation (DEV) - Mean difference of the predicted versus the actual position of a track.
- 14. Collimation Distribution - Variations of the closest surveillance return relative to the beacon return that was being tracked (primary radar).

15. Permanent Echo (PE) Verification - Range of the adapted PE in whole and eighths of a mile, together with the mean error in whole and tenths of Azimuth Change Pulses (ACP).

16. The mean predicted versus actual position of all the tracks for the site.

5. Range, Azimuth, Radar Reenforced Evaluator (RARRE) Program.

The RARRE program provides the capability to retrieve, sort, and print target primary and secondary (beacon) radar information pertaining to all Mode 3/A beacon equipped aircraft detected by any number of radar sites. The data are received from a CD RECORD format tape and run on the HCS.

APPENDIX C
TEST VERIFICATION REQUIREMENTS TRACEABILITY
MATRIX (TVRTM)

Paragraph No.	Test		Test Location	C/NC	Support Organizations	Test Designation	TEMP Ref
	I	O					
1) 3.2.1.1 Electrical Performance Requirements	X		ZHU ZME	C	ZHU ZME QNM	NPHU NPME	7.5
2) 3.2.1.1.1 Antenna Main Lobe Beam Width Error	X		ZHU ZME	C	ZHU ZME QNM	NPHU NPME	7.5
3) 3.2.1.1.2 Boresight Error	X		ZHU ZME	C	ZHU ZME QNM	NPHU NPME	7.5
4) 3.2.1.1.5 Sidelobe Level Error	X		ZHU ZME	C	ZHU ZME QNM	NPHU NPME	7.5

LEGEND:

C Critical
 I Integrational
 NC Noncritical
 O Operational
 QNM Newport ARSR-3
 REF Reference
 ZHU Houston ARTCC
 ZME Memphis ARTCC