

te technical note tech

# Operational Test and Evaluation (OT&E) Operational Test Procedures for Type V/VI Fixed Ground Antenna Radome (FGAR)

Leonard H. Baker

DISTRIBUTION STATEMENT A

Approved for public release;  
Distribution Unlimited

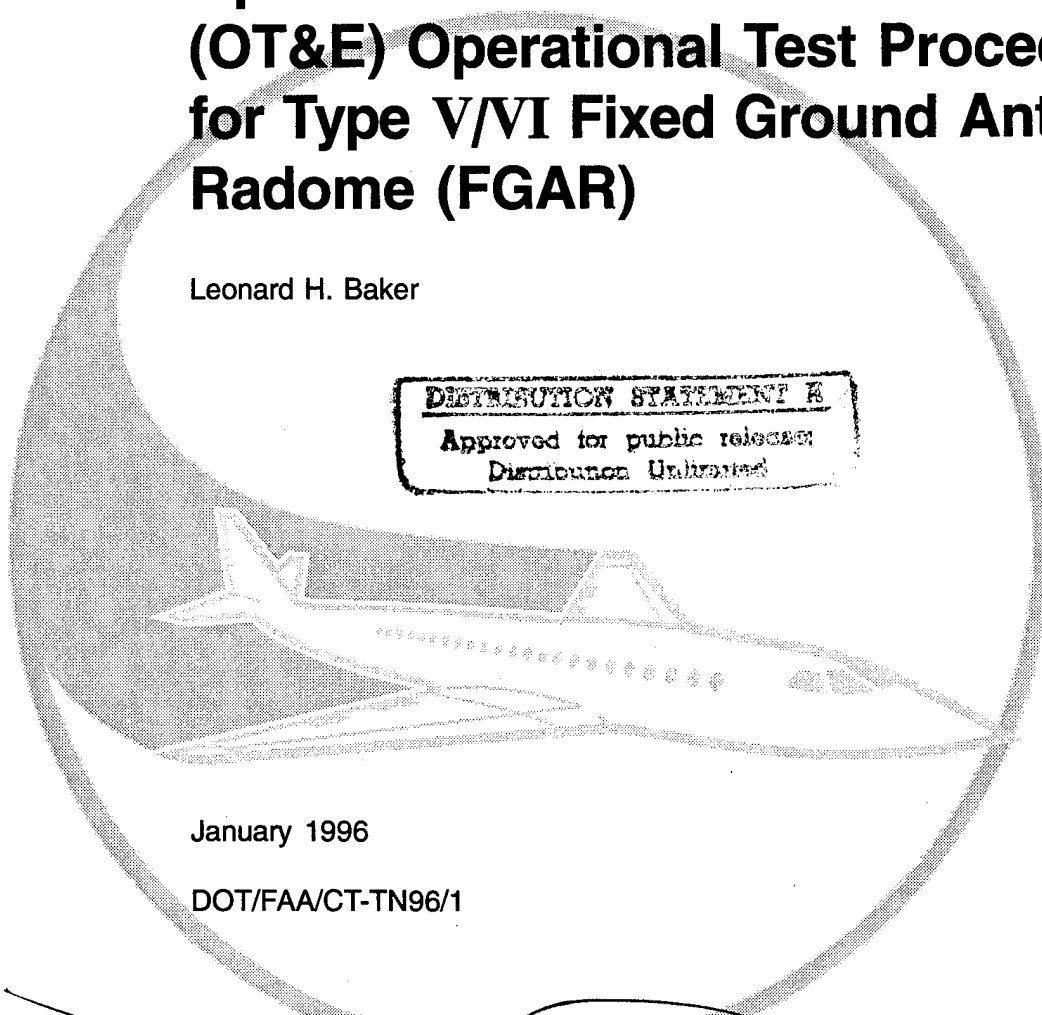

January 1996

DOT/FAA/CT-TN96/1

Document is on file at the Technical Center Library,  
Atlantic City International Airport, NJ 08405

19960228 085



U.S. Department of Transportation  
Federal Aviation Administration

Technical Center  
Atlantic City Airport, NJ 08405

#### **NOTICE**

This document is disseminated under the sponsorship of the U.S. Department of Transportation in the interest of information exchange. The United States Government assumes no liability for the contents or use thereof.

The United States Government does not endorse products or manufacturers. Trade or manufacturers' names appear herein solely because they are considered essential to the objective of this report.

1. Report No. DOT/FAA/CT-TN96/1	2. Government Accession No.	3. Recipient's Catalog No.	
4. Title and Subtitle OPERATIONAL TEST AND EVALUATION (OT&E) OPERATIONAL TEST PROCEDURES FOR TYPE V/VI FIXED GROUND ANTENNA RADOME (FGAR)		5. Report Date January 1996	6. Performing Organization Code
7. Author(s) Leonard H. Baker,ACT-310B;Harold G. Sedgwick,Raytheon		8. Performing Organization Report No. DOT/FAA/CT-TN96/1	
9. Performing Organization Name and Address U.S. Department of Transportation Federal Aviation Administration Technical Center Atlantic City International Airport, NJ 08405		10. Work Unit No. (TRAIS)	11. Contract or Grant No.
12. Sponsoring Agency Name and Address U.S. Department of Transportation Federal Aviation Administration Technical Center Atlantic City International Airport, NJ 08405		13. Type of Report and Period Covered Technical Note	
15. Supplementary Notes		14. Sponsoring Agency Code	
16. Abstract  This document defines the Type V/VI Fixed Ground Antenna Radome (FGAR) Operational Test and Evaluation (OT&E) operational test procedures that will be performed at Federal Aviation Administration (FAA) field facilities. These test procedures will be performed following the Contractor's Acceptance Inspection (CAI) and the facilities have been returned to operational service. The OT&E testing will be limited to electromagnetic performance evaluation.  The Type V/VI FGAR is specially designed to be mounted on a standard Air Route Surveillance Radar (ARSR)-3 tower. The present ARSR-3 radome is not large enough to accommodate the Mode Select Beacon System (Mode S) back-to-back antenna.			
17. Key Words Fixed Ground Antenna Radome (FGAR) Operational Test and Evaluation (OT&E). Operational		18. Distribution Statement Document is on file at the Technical Center Library, Atlantic City International Airport, NJ 08405	
19. Security Classif. (of this report) Unclassified	20. Security Classif. (of this page) Unclassified	21. No. of Pages 39	22. Price

## TABLE OF CONTENTS

	Page
1. INTRODUCTION	1
2. REFERENCE DOCUMENTS	1
2.1 Federal Aviation Administration (FAA) Orders	1
2.2 FAA Standards	1
2.3 FAA Specifications	1
2.4 Other FAA Documents	1
3. SYSTEM DESCRIPTION	2
3.1 System Overview	2
3.2 Interfaces Overview	3
4. TEST MANAGEMENT	5
4.1 Test Director	5
4.2 Coordination	5
4.3 Deviations	5
4.4 Data Elements	5
4.5 Data Base Design and Structure	5
4.6 Initial Setup/Configuration	5
4.7 Test Personnel Requirements	5
4.8 Test Support Hardware, Software, and Documentation	5
4.9 Data Collection, Recording, and Reduction	6
4.10 Analysis Methods	6
5. ACRONYMS	7
APPENDIX A            Test Procedures	
APPENDIX B            Data Analysis Programs	
APPENDIX C            Test Forms	

## LIST OF ILLUSTRATIONS

Figure		Page
3.2.2-1	Type V/VI FGAR Interfaces Block Diagram	4

## 1. INTRODUCTION.

The objectives of Operational Test and Evaluation (OT&E) testing are to verify the Fixed Ground Antenna Radome (FGAR) does not degrade the electromagnetic performance of the Air Route Surveillance Radar (ARSR)-3 and Air Traffic Control Radar Beacon System (ATCRBS) antenna patterns, and that it meets the other criteria specified in the OT&E Test Plan and the Test and Evaluation (T&E) Master Plan (TEMP) Test Verification Requirements Traceability Matrix (TVRTM).

The first Type V/VI FGAR will be installed at the Newport, Attala County, Mississippi (MS) ARSR-3 En Route Radar Facility (QNM) and is considered a First Article. The OT&E Operational testing will be limited to electromagnetic performance testing using "live" primary (ARSR-3) and secondary (beacon) aircraft (targets of opportunity) radar data. These data will be collected and analyzed by the Memphis (ZME) and Houston (ZHU) Air Route Traffic Control Centers (ARTCC). (The Houston ARTCC [ZHU] is not presently receiving data from the Newport ARSR-3 En Route Radar Facility [QNM].)

## 2. REFERENCE DOCUMENTS.

### 2.1 FEDERAL AVIATION ADMINISTRATION (FAA) ORDERS.

Order 1814.4B	FAA NAS Test and Evaluation Policy
Order 6100.1C	Maintenance of NAS En Route Stage A Air Traffic Control System

### 2.2 FAA STANDARDS.

FAA-STD-024b	Content and Format Requirements for the Preparation of Test and Evaluation Documentation
--------------	--

### 2.3 FAA SPECIFICATIONS.

FAA-E-2773b	Specification for Fixed Ground Antenna Radome (Mode S Compatible)
-------------	---

### 2.4 OTHER FAA DOCUMENTS.

DTFA01-93-C-00075	Fixed Ground Antenna Radome (FGAR) Contract
DOT/FAA/CT-TN93/17	Fixed Ground Antenna Radome (FGAR) Master Test and Evaluation Plan (TEMP)
DOT/FAA/CT-TN95/23	Fixed Ground Antenna Radome (FGAR) Type I/III OT&E Integration and OT&E Operational Final Test Report
DOT/FAA/CT-TN95/69	Operational Test and Evaluation (OT&E) Operational Test Plan for Type V/VI Fixed Ground Antenna Radome (FGAR)
FAA-4306B-8H	User's Manual - Common Digitizer Data Reduction (COMDIG) Program
FAA-4306F-3H	User's Manual - Common Digitizer Record (CD RECORD) Program

FAA-4306M-6H	User's Manual - Range, Azimuth, Radar Reinforced Evaluator (RARRE) Program
FAA-4306N-6H	User's Manual - Quick Analysis of Radar Sites (QARS) Program
FAA-4306P-9H	User's Manual - Beacon False Target Analysis (BFTA) Program

### 3. SYSTEM DESCRIPTION.

#### 3.1 SYSTEM OVERVIEW.

The FGAR supplies optimal protection from the outside environment while providing minimal degradation to the electromagnetic performance characteristics of the enclosed antenna(s). The hardware required for installation, i.e., cables, wiring, support equipment, radome mounted/ supported equipment, radome base ring (Type II only), and spare parts are part of the FGAR procurement. There are five types of radomes (no Type IV radomes are being procured). They are the following:

a. Type I Radome.

This type of radome will provide an environmental enclosure for a collocated L-band surveillance radar parabolic reflector and top-mounted dual-faced L-band beacon phased array antenna. The radome will be capable of withstanding wind velocities of 150 miles per hour (MPH). They will have an inside diameter of 59 feet at their widest point, and will fit a base-ring diameter equal to the present CW-396A radome. The enclosed antennas will rotate at a speed of either 5 or 6 revolutions per minute (RPM).

b. Type II Radome.

This type of radome will provide an environmental enclosure for a dual-faced L-band beacon phased array antenna consisting of two identical rectangular back-to-back antennas approximately 6 feet high by 27 feet wide, rotating at speeds up to 5 RPM. The radome will be capable of withstanding wind velocities of 150 MPH and have an inside diameter of 35 feet at its widest point. It will fit the standard beacon-only antenna platform.

c. Type III Radome.

This type of radome will be identical to the Type I in all respects, except that it will be capable of withstanding wind velocities of 100 MPH maximum.

d. Type V Radome.

This type of radome will provide an environmental enclosure for a collocated L-band radar reflector and top-mounted dual-faced L-band beacon phased array antenna. The radome will be capable of withstanding wind velocities of 150 MPH. They will have an inside diameter of 57.5 feet at their widest point, and will fit a base-ring diameter equal to the present ARSR-3 radome.

e. Type VI Radome.

This type of radome will be identical to the Type V in all respects, except that it will be capable of withstanding wind velocities of 100 MPH maximum.

3.2 INTERFACES OVERVIEW.

3.2.1 Mechanical Interface.

a. The Type I/III and V/VI FGARs interface mechanically with the existing antenna tower radome base ring.

b. The Type II FGAR radome base ring is part of the procurement and interfaces with the antenna tower.

3.2.2 Electrical Interface.

All types of FGARs interface electrically with the following facility systems:

- a. Electrical system.
- b. Lightning protection system.
- c. Remote Maintenance Monitoring System (RMMS)/Environmental Remote Monitoring Subsystem (ERMS).
- d. Transient protection.

A block diagram of the Type V/VI interfaces are shown in figure 3.2.2-1.

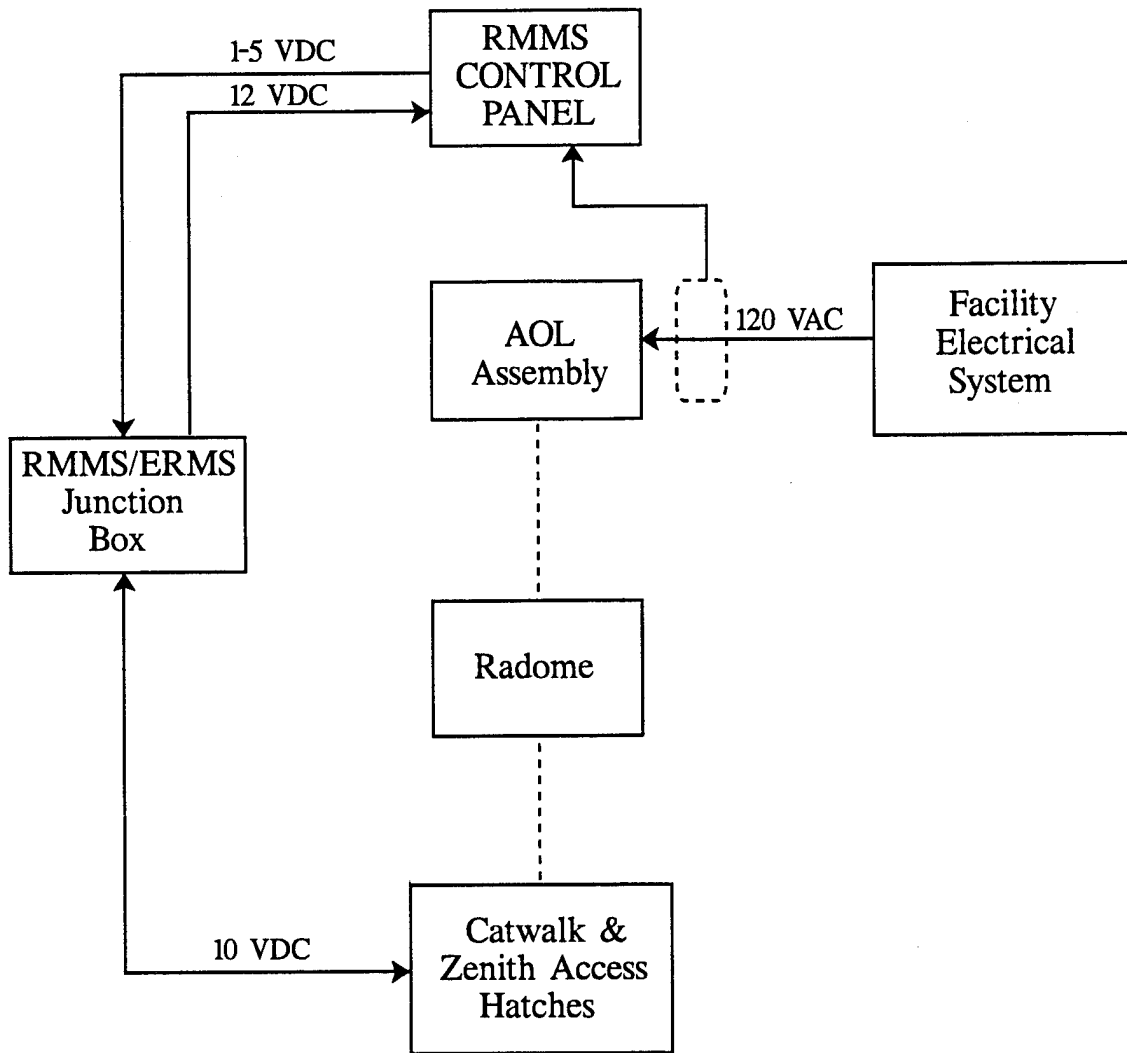

LEGEND

- Mechanical
- Electrical
- ( ) Inductive Coupling

FIGURE 3.2.2-1. TYPE V/VI FGAR INTERFACES BLOCK DIAGRAM

#### 4. TEST MANAGEMENT.

##### 4.1 TEST DIRECTOR.

A Test Director (TD) will be appointed to supervise the testing. The TD's duties include:

- a. Scheduling the required test facilities (see appendix A).
- b. Collection of test data, e.g., computer printouts, etc.
- c. Analysis of test data and documentation.

##### 4.2 COORDINATION.

The TD will be responsible for coordinating activities of the Newport ARSR-3 En Route Radar Facility (QNM) and the Memphis (ZME) and Houston (ZHU) ARTCCs.

##### 4.3 DEVIATIONS.

Not applicable.

##### 4.4 DATA ELEMENTS.

Not applicable.

##### 4.5 DATA BASE DESIGN AND STRUCTURE.

Not applicable.

##### 4.6 INITIAL SETUP/CONFIGURATION.

Prior to commencing OT&E Operational testing, the contractor must have:

- a. Completed the installation of the FGAR.
- b. Removed any scaffolding, cranes, etc., required for its installation.
- c. Completed the First Article Design Qualification Test (DQT).
- d. Completed the Site Acceptance Test (SAT).
- e. Completed the Contractor Acceptance Inspection (CAI).

##### 4.7 TEST PERSONNEL REQUIREMENTS.

The Technical Support Staff (TSS) and HOST Computer System (HCS) operators at the Memphis (ZME) and Houston (ZHU) ARTCCs will be required to support the testing.

##### 4.8 TEST SUPPORT HARDWARE, SOFTWARE, AND DOCUMENTATION.

The hardware and software required to support the testing are:

- a. Newport ARSR-3 En Route Radar Facility (QNM).
  1. ARSR-3
  2. Air Traffic Control Beacon Interrogator (ATCBI)-5
- b. Memphis (ZME) and Houston (ZHU) ARTCC HCSs.

- c. The QARS, BFTA, RARRE, COMDIG, and CD RECORD programs (see appendix B).

#### 4.9 DATA COLLECTION, RECORDING, AND REDUCTION.

The data collection, recording, and reduction will be accomplished by the Memphis (ZME) and Houston (ZHU) ARTCCs TSS personnel. They will run the QARS, BFTA, RARRE, and COMDIG programs on their HCS using primary (ARSR-3) and secondary (beacon) radar data from the Newport ARSR-3 En Route Radar Facility (QNM).

#### 4.10 ANALYSIS METHODS.

These data analysis will be accomplished at the Memphis (ZME) and Houston (ZHU) ARTCCs. TSS personnel supporting the test will analyze the radar data supplied by the QARS, BFTA, RARRE, and COMDIG programs. When the analysis has been completed, they will prepare a report and forward it to the TD.

5. ACRONYMS.

ACP Azimuth Change Pulse (QARS program)  
ALT Altitude (QARS program)  
AOL Aircraft Obstruction Light(s)  
ARSR Air Route Surveillance Radar  
ARTCC Air Route Traffic Control Center  
ASPLT Azimuth Split (QARS program)  
ATCBI Air Traffic Control Beacon Interrogator  
ATCRBS Air Traffic Control Radar Beacon System  
AZ Azimuth (QARS program)  
BCN Beacon (QARS program)  
BFTA Beacon False Target Analysis (computer program)  
BLIP Blip/Scan Ratio (QARS program)  
CAI Contract Acceptance Inspection  
CD Common Digitizer  
CDRECORD Common Digitizer Record (computer program)  
COLL Collimation (QARS program)  
COMDIG Common Digitizer Data Reduction (computer program)  
CW Radomes (military designation)  
DRG Data Receiver Group  
DEV Deviation (QARS program)  
DQT Design Qualification Test  
ERMS Environmental Remote Monitoring Subsystem  
FAA Federal Aviation Administration  
FALSE-BCN False Beacon (QARS program)  
FGAR Fixed Ground Antenna Radome  
HCS HOST Computer System  
HOST Air Traffic Control HOST Computer System (not an acronym)  
M3REL Mode 3/A Reliability Percentage (QARS program)  
M3VAL Mode 3/A Validity Percentage (QARS program)  
MCREL Mode C Reliability Percentage (QARS program)

MCVAL	Mode C Validity (QARS program)
Mode S	Mode Select Beacon System
MOE	Measures of Effectiveness
MOP	Measures of Performance
MPH	Miles Per Hour
MS	Mississippi
MTI	Moving Target Indicator (QARS program)
NAS	National Airspace System
NML	Normal (QARS program)
OT&E	Operational Test and Evaluation
PE	Permanent Echo
QARS	Quick Analysis of Radar Sites (computer program)
QNM	Newport ARSR-3 En Route Radar Facility (identifier)
R/R	Radar Reinforced (QARS program)
RAR	Ring-A-Round (QARS program)
RARRE	Range, Azimuth, Radar Reenforced Evaluator (computer program)
REF	Reflections (QARS program)
RMMS	Remote Maintenance Monitoring System
RPM	Revolutions Per Minute
RSPLT	Range Split (QARS program)
SAT	Site Acceptance Test
SCAN	Blip/Scan Ratio (QARS program)
SCH	Combined Moving Target Indicator and Normal Video (QARS program)
T&E	Test and Evaluation
TD	Test Director
TDR	Test Discrepancy Report
TEMP	Test and Evaluation Master Plan
TSS	Technical Support Staff
TVRTM	Test Verification Requirements Traceability Matrix
VAC	Volts Alternating Current
VDC	Volts Direct Current

ZHU Houston Air Route Traffic Control Center (identifier)  
ZME Memphis Air Route Traffic Control Center (identifier)  
ZER Code Zero Percentage (QARS program)

APPENDIX A  
TEST PROCEDURES

## TEST PROCEDURES

### 1. TEST TITLE.

NPME-1A/B Memphis ARTCC (ZME)/Newport ARSR-3 (QNM) Quick Analysis of Radar Sites (QARS) Program Test

#### 1.1 TEST OBJECTIVE.

The objective is to determine if there are any differences in the performance characteristics of the primary (ARSR-3) and/or secondary (beacon) radar data received from the Newport ARSR-3 En Route Radar Facility (QNM).

#### 1.2 MEASURES OF EFFECTIVENESS (MOE).

The FGAR does not affect the accuracy of the primary (ARSR-3) or secondary (beacon) radar data received from the Newport ARSR-3 En Route Radar Facility (QNM).

#### 1.3 MEASURES OF PERFORMANCE (MOP).

The accuracy of the primary (ARSR-3) and secondary (beacon) radar data being received by the ARTCC is the same, before and after the FGAR is installed.

#### 1.4 EVALUATION CRITERIA.

There is no change in the accuracy of the primary (ARSR-3) or secondary (beacon) radar data received from the Newport ARSR-3 En Route Radar Facility (QNM), between the original radome and the FGAR.

#### 1.5 PROCEDURES.

- a. NPME-1A, Original Radome Installed - Memphis ARTCC (ZME)/Newport ARSR-3 (QNM) QARS Program Test.
  1. The ARTCC HCS operators will run the QARS program on primary (ARSR-3) and secondary (beacon) radar data received from the Newport ARSR-3 En Route Radar Facility (QNM).
  2. The QARS program printouts will be given to the TSS personnel for analysis.
- b. NPME-1B, FGAR Installed - Memphis ARTCC (ZME)/Newport ARSR-3 (QNM) QARS Program Test.
  1. The ARTCC HCS operators will run the QARS program on primary (ARSR-3) and secondary (beacon) radar data received from the Newport ARSR-3 En Route Radar Facility (QNM), after the contractor has:
    - (a) Installed the FGAR and removed any scaffolding, cranes, etc., required for its installation.
    - (b) Completed the First Article DQT.
    - (c) Completed the SAT.
    - (d) Completed the CAI.

2. The QARS program printouts will be given to the TSS personnel for analysis.

c. Data Analysis.

When the QARS program has been run on primary (ARSR-3) and secondary (beacon) radar data with the original radome and again after the FGAR has been installed, the TSS personnel will compare these data to determine if there are any changes in the accuracy or any other anomalies. Upon completion of the analysis, the TSS personnel will submit a report to the TD.

## 2. TEST TITLE.

NPME-2A/B Memphis ARTCC (ZME)/Newport ARSR-3 (QNM) Beacon False Target Analysis (BFTA) Program Test

### 2.1 TEST OBJECTIVE.

The objective is to determine if there are any differences in the number and/or types of beacon false targets, i.e., splits, ring-around, reflections, etc., in the beacon data received from the Newport ARSR-3 En Route Radar Facility (QNM).

### 2.2 MOE.

The FGAR does not increase the number of beacon false targets included in the beacon data received by the ARTCC.

### 2.3 MOP.

The number of beacon false targets are the same or less, after the FGAR is installed.

### 2.4 EVALUATION CRITERIA.

The number of beacon false targets in the beacon data received by the ARTCC is either the same or less than the number received before the FGAR was installed.

### 2.5 PROCEDURES.

a. NPME-2A, Original Radome Installed - Memphis ARTCC (ZME)/Newport ARSR-3 (QNM) BFTA Program Test.

1. The ARTCC HCS operators will run the BFTA program on beacon data received from the Newport ARSR-3 En Route Radar Facility (QNM).
2. The BFTA program printouts will be given to the TSS personnel for analysis.

b. NPME-2B, FGAR Installed - Memphis ARTCC (ZME)/Newport ARSR-3 (QNM) BFTA Program Test.

1. The ARTCC HCS operators will run the BFTA program on beacon data received from the Newport ARSR-3 En Route Radar Facility (QNM), after the contractor has:
  - (a) Installed the FGAR and removed any scaffolding, cranes, etc., required for its installation.
  - (b) Completed the First Article DQT.
  - (c) Completed the SAT.
  - (d) Completed the CAI.
2. The BFTA program printouts will be given to the TSS personnel for analysis.

c. Data Analysis.

When the BFTA program has been run on beacon data with the original radome and again after the FGAR is installed, the TSS personnel will compare these data to determine if there are any changes in the number and/or types of beacon false targets. Upon completion of the analysis, the TSS personnel will submit a report to the TD.

### 3. TEST TITLE.

NPME-3A/B Memphis ARTCC (ZME)/Newport ARSR-3 (QNM) Common Digitizer Data Reduction (COMDIG) Program Test

#### 3.1 TEST OBJECTIVE.

The objective is to determine if there are any changes in the position of the primary (ARSR-3) Permanent Echoes (PE) and/or secondary (beacon) "parrot(s)," in the radar data received from the Newport ARSR-3 En Route Radar Facility (QNM).

#### 3.2 MOE.

The FGAR does not change the position of the primary (ARSR-3) PEs or secondary (beacon) "parrot(s)," in the radar data received by the ARTCC.

#### 3.3 MOP.

The position of the primary (ARSR-3) and secondary (beacon) "parrot(s)" are the same.

#### 3.4 EVALUATION CRITERIA.

The primary (ARSR-3) and secondary (beacon) "parrot(s)" positions are the same, before and after the FGAR is installed.

#### 3.5 PROCEDURES.

- a. NPME-3A, Original Radome Installed - Memphis ARTCC (ZME)/Newport ARSR-3 (QNM) COMDIG Program Test.
  1. The ARTCC HCS operators will run the COMDIG program on primary (ARSR-3) and secondary (beacon) radar data received from the Newport ARSR-3 En Route Radar Facility (QNM).
  2. The COMDIG program printouts will be given to the TSS personnel for analysis.
- b. NPME-3B, FGAR Installed - Memphis ARTCC (ZME)/Newport ARSR-3 (QNM) COMDIG Program Test.
  1. The ARTCC HCS operators will run the COMDIG program on primary (ARSR-3) and secondary (beacon) radar data received from the Newport ARSR-3 En Route Radar Facility (QNM), after the contractor has:
    - (a) Installed the FGAR and removed any scaffolding, cranes, etc., required for its installation.
    - (b) Completed the First Article DQT.
    - (c) Completed the SAT.
    - (d) Completed the CAI.
  2. The COMDIG program printouts will be given to the TSS personnel for analysis.

c. Data Analysis.

When the COMDIG program has been run on primary (ARSR-3) and secondary (beacon) radar data with the original radome and again after the FGAR is installed, the TSS personnel will compare these data to determine if there are any changes in the position of the primary (ARSR-3) PEs or secondary (beacon) "parrot(s)." Upon completion of the analysis, the TSS personnel will submit a report to the TD.

#### 4. TEST TITLE.

NPME-4A/B Memphis ARTCC (ZME)/Newport ARSR-3 (QNM) Range, Azimuth, Radar Reinforced Evaluator (RARRE) Program Test

#### 4.1 TEST OBJECTIVE.

The objective is to determine if there are any changes in the overall radar reinforcement percentage, altitude coverage, and/or range coverage in the Newport ARSR-3 En Route Radar Facility (QNM) primary (ARSR-3) and secondary (beacon) radar data received by the ARTCC, after the FGAR is installed.

#### 4.2 MOE.

The FGAR does not change the primary (ARSR-3) or secondary (beacon) overall radar reinforcement percentage, altitude coverage, or range coverage.

#### 4.3 MOP.

The overall radar reinforcement percentage, altitude coverage, and range coverage are the same or greater, after the FGAR is installed.

#### 4.4 EVALUATION CRITERIA.

The overall radar reinforcement percentage, altitude coverage, or range coverage do not decrease, after the FGAR is installed.

#### 4.5 PROCEDURES.

- a. NPME-4A, Original Radome Installed - Memphis ARTCC (ZME)/Newport ARSR-3 (QNM) RARRE Program Test.
  1. The ARTCC HCS operators will run the RARRE program on primary (ARSR-3) and secondary (beacon) radar data received from the Newport ARSR-3 En Route Radar Facility (QNM).
  2. The RARRE program printouts will be given to the TSS personnel for analysis.
- b. NPME-4B, FGAR Installed - Memphis ARTCC (ZME)/Newport ARSR-3 (QNM) RARRE Program Test.
  1. The ARTCC HCS operators will run the RARRE program on primary (ARSR-3) and secondary (beacon) radar data received from the Newport ARSR-3 En Route Radar Facility (QNM), after the contractor has:
    - (a) Installed the FGAR and removed any scaffolding, cranes, etc., required for its installation.
    - (b) Completed the First Article DQT.
    - (c) Completed the SAT.
    - (d) Completed the CAI.
  2. The RARRE program printouts will be given to the TSS personnel for analysis.

c. Data Analysis.

When the RARRE program has been run on primary (ARSR-3) and secondary (beacon) radar data with the original radome and again after the FGAR is installed, the TSS personnel will compare these data to determine if there are any changes in the overall radar reenforcement percentage, altitude coverage, or range coverage. Upon completion of the analysis, the TSS personnel will submit a report to the TD.

5. TEST TITLE.

NPHU-1A/B Houston ARTCC (ZHU)/Newport ARSR-3 (QNM) Quick Analysis of Radar Sites (QARS) Program Test

5.1 TEST OBJECTIVE.

The objective is to determine if there are any differences in the performance characteristics of the primary (ARSR-3) and/or secondary (beacon) radar data received from the Newport ARSR-3 En Route Radar Facility (QNM).

5.2 MOE.

The FGAR does not affect the accuracy of the primary (ARSR-3) or secondary (beacon) radar data received from the Newport ARSR-3 En Route Radar Facility (QNM).

5.3 MOP.

The accuracy of the primary (ARSR-3) and secondary (beacon) radar data being received by the ARTCC is the same, before and after the FGAR is installed.

5.4 EVALUATION CRITERIA.

There is no change in the accuracy of the primary (ARSR-3) or secondary (beacon) radar data received from the Newport ARSR-3 En Route Radar Facility (QNM), between the original radome and the FGAR.

5.5 PROCEDURES.

- a. NPHU-1A, Original Radome Installed - Houston ARTCC (ZHU)/ Newport ARSR-3 (QNM) QARS Program Test.
  1. The ARTCC HCS operators will run the QARS program on primary (ARSR-3) and secondary (beacon) radar data received from the Newport ARSR-3 En Route Radar Facility (QNM).
  2. The QARS program printouts will be given to the TSS personnel for analysis.
- b. NPHU-1B, FGAR Installed - Houston ARTCC (ZHU)/Newport ARSR-3 (QNM) QARS Program Test.
  1. The ARTCC HCS operators will run the QARS program on primary (ARSR-3) and secondary (beacon) radar data received from the Newport ARSR-3 En Route Radar Facility (QNM), after the contractor has:
    - (a) Installed the FGAR and removed any scaffolding, cranes, etc., required for its installation.
    - (b) Completed the First Article DQT.
    - (c) Completed the SAT.
    - (d) Completed the CAI.
  2. The QARS program printouts will be given to the TSS personnel for analysis.

c. Data Analysis.

When the QARS program has been run on primary (ARSR-3) and secondary (beacon) radar data with the original radome and again after the FGAR has been installed, the TSS personnel will compare these data to determine if there are any changes in the accuracy or any other anomalies. Upon completion of the analysis, the TSS personnel will submit a report to the TD.

6. TEST TITLE.

NPHU-2A/B Houston ARTCC (ZHU)/Newport ARSR-3 (QNM) Beacon False Target Analysis (BFTA) Program Test

6.1 TEST OBJECTIVE.

The objective is to determine if there are any differences in the number and/or types of beacon false targets, i.e., splits, ring-around, reflections, etc., in the beacon data received from the Newport ARSR-3 En Route Radar Facility (QNM).

6.2 MOE.

The FGAR does not increase the number of beacon false targets included in the beacon data received by the ARTCC.

6.3 MOP.

The number of beacon false targets are the same or less, after the FGAR is installed.

6.4 EVALUATION CRITERIA.

The number of beacon false targets in the beacon data received by the ARTCC is either the same or less than the number received before the FGAR was installed.

6.5 PROCEDURES.

- a. NPHU-2A, Original Radome Installed - Houston ARTCC (ZHU)/Newport ARSR-3 (QNM) BFTA Program Test.
  1. The ARTCC HCS operators will run the BFTA program on beacon data received from the Newport ARSR-3 En Route Radar Facility (QNM).
  2. The BFTA program printouts will be given to the TSS personnel for analysis.
- b. NPHU-2B, FGAR Installed - Houston ARTCC (ZHU)/Newport ARSR-3 (QNM) BFTA Program Test.
  1. The ARTCC HCS operators will run the BFTA program on beacon data received from the Newport ARSR-3 En Route Radar Facility (QNM), after the contractor has:
    - (a) Installed the FGAR and removed any scaffolding, cranes, etc., required for its installation.
    - (b) Completed the First Article DQT.
    - (c) Completed the SAT.
    - (d) Completed the CAI.

c. Data Analysis.

When the BFTA program has been run on beacon data with the original radome and again after the FGAR has been installed, the TSS personnel will compare these data to determine if there are any changes in the number and/or types of beacon false targets. Upon completion of the analysis, the TSS personnel will submit a report to the TD.

## 7. TEST TITLE.

NPHU-3A/B Houston ARTCC (ZHU)/Newport ARSR-3 (QNM) Common Digitizer Data Reduction (COMDIG) Program Test

### 7.1 TEST OBJECTIVE.

The objective is to determine if there are any changes in the position of the primary (ARSR-3) PEs and/or secondary (beacon) "parrot(s)," in the radar data received from the Newport ARSR-3 En Route Radar Facility (QNM).

### 7.2 MOE.

The FGAR does not change the position of the primary (ARSR-3) PEs or secondary (beacon) "parrot(s)," in the radar data received by the ARTCC.

### 7.3 MOP.

The position of the primary (ARSR-3) and secondary (beacon) "parrot(s)" are the same.

### 7.4 EVALUATION CRITERIA.

The primary (ARSR-3) and secondary (beacon) "parrot(s)" positions are the same, before and after the FGAR is installed.

### 7.5 PROCEDURES.

- a. NPHU-3A, Original Radome Installed - Houston ARTCC (ZHU)/Newport ARSR-3 (QNM) COMDIG Program Test.
  1. The ARTCC HCS operators will run the COMDIG program on primary (ARSR-3) and secondary (beacon) radar data received from the Newport ARSR-3 En Route Radar Facility (QNM).
  2. The COMDIG program printouts will be given to the TSS personnel for analysis.
- b. NPHU-3B, FGAR Installed - Houston ARTCC (ZHU)/Newport ARSR-3 (QNM) COMDIG Program Test.
  1. The ARTCC HCS operators will run the COMDIG program on primary (ARSR-3) and secondary (beacon) radar data received from the Newport ARSR-3 En Route Radar Facility (QNM), after the contractor has:
    - (a) Installed the FGAR and removed any scaffolding, cranes, etc., required for its installation.
    - (b) Completed the First Article DQT.
    - (c) Completed the SAT.
    - (d) Completed the CAI.
  2. The COMDIG program printouts will be given to the TSS personnel for analysis.

c. Data Analysis.

When the COMDIG program has been run on primary (ARSR-3) and secondary (beacon) radar data with the original radome and again after the FGAR is installed, the TSS personnel will compare these data to determine if there are any changes in the position of the primary (ARSR-3) PEs and secondary (beacon) "parrot(s)." Upon completion of the analysis, the TSS personnel will submit a report to the TD.

8. TEST TITLE.

NPHU-4A/B Houston ARTCC (ZHU)/Newport ARSR-3 (QNM) Range, Azimuth, Radar Reinforced Evaluator (RARRE) Program Test

8.1 TEST OBJECTIVE.

The objective is to determine if there are any changes in the overall radar reinforcement percentage, altitude coverage, and/or range coverage in the Newport ARSR-3 En Route Radar Facility (QNM) primary (ARSR-3) and secondary (beacon) radar data received by the ARTCC, after the FGAR is installed.

8.2 MOE.

The FGAR does not change the primary (ARSR-3) or secondary (beacon) overall radar reinforcement percentage, altitude coverage, or range coverage.

8.3 MOP.

The overall radar reinforcement percentage, altitude coverage, and range coverage are the same or greater, after the FGAR is installed.

8.4 EVALUATION CRITERIA.

The overall radar reinforcement percentage, altitude coverage, or range coverage do not decrease, after the FGAR is installed.

8.5 PROCEDURES.

a. NPME-4A, Original Radome Installed - Houston ARTCC (ZHU)/Newport ARSR-3 (QNM) RARRE Program Test.

1. The ARTCC HCS operators will run the RARRE program on primary (ARSR-3) and secondary (beacon) radar data received from the Newport ARSR-3 En Route Radar Facility (QNM).
2. The RARRE program printouts will be given to the TSS personnel for analysis.

b. NPME-4B, FGAR Installed - Houston ARTCC (ZHU)/Newport ARSR-3 (QNM) RARRE Program Test.

1. The ARTCC HCS operators will run the RARRE program on primary (ARSR-3) and secondary (beacon) radar data received from the Newport ARSR-3 En Route Radar Facility (QNM), after the contractor has:
  - (a) Installed the FGAR and removed any scaffolding, cranes, etc., required for its installation.
  - (b) Completed the First Article DQT.
  - (c) Completed the SAT.
  - (d) Completed the CAI.
2. The RARRE program printouts will be given to the TSS personnel for analysis.

c. Data Analysis.

When the RARRE program has been run on primary (ARSR-3) and secondary (beacon) radar data with the original radome and again after the FGAR is installed, the TSS personnel will compare these data to determine if there are any changes in the overall radar reenforcement percentage, altitude coverage, or range coverage. Upon completion of the analysis, the TSS personnel will submit a report to the TD.

9. LIST OF TEST TITLES.

NPHU-1A Original Radome Installed - Houston ARTCC (ZHU)/Newport ARSR-3 (QNM) QARS Program Test

NPHU-1B FGAR Installed - Houston ARTCC (ZHU)/Newport ARSR-3 (QNM) QARS Program Test

NPHU-2A Original Radome Installed - Houston ARTCC (ZHU)/Newport ARSR-3 (QNM) BFTA Program Test

NPHU-2B FGAR Installed - Houston ARTCC (ZHU)/Newport ARSR-3 (QNM) BFTA Program Test

NPHU-3A Original Radome Installed - Houston ARTCC (ZHU)/Newport ARSR-3 (QNM) COMDIG Program Test

NPHU-3B FGAR Installed - Houston ARTCC (ZHU)/Newport ARSR-3 (QNM) COMDIG Program Test

NPHU-4A Original Radome Installed - Houston ARTCC (ZHU)/Newport ARSR-3 (QNM) RARRE Program Test

NPHU-4B FGAR Installed - Houston ARTCC (ZHU)/Newport ARSR-3 (QNM) RARRE Program Test

NPME-1A Original Radome Installed - Memphis ARTCC (ZME)/Newport ARSR-3 (QNM) QARS Program Test

NPME-1B FGAR Installed - Memphis ARTCC (ZME)/Newport ARSR-3 (QNM) QARS Program Test

NPME-2A Original Radome Installed - Memphis ARTCC (ZME)/Newport ARSR-3 (QNM) BFTA Program Test

NPME-2B FGAR Installed - Memphis ARTCC (ZME)/Newport ARSR-3 (QNM) BFTA Program Test

NPME-3A Original Radome Installed - Memphis ARTCC (ZME)/Newport ARSR-3 (QNM) COMDIG Program Test

NPME-3B FGAR Installed - Memphis ARTCC (ZME)/Newport ARSR-3 (QNM) COMDIG Program Test

NPME-4A Original Radome Installed - Memphis ARTCC (ZME)/Newport ARSR-3 (QNM) RARRE Program Test

NPME-4B FGAR Installed - Memphis ARTCC (ZME)/Newport ARSR-3 (QNM) RARRE Program Test

APPENDIX B  
DATA ANALYSIS PROGRAMS

## DATA ANALYSIS PROGRAMS

The programs that will be used to analyze the electromagnetic performance of the primary (ARSR-3) and secondary (beacon) radar data are described below.

1. Beacon False Target Analysis (BFTA) Program.

The BFTA program provides a tool to investigate and evaluate false target problems associated with the ATCRBS/Mode Select Beacon System (Mode S). The BFTA program retrieves and processes beacon target information relative to all Mode 3/A beacon equipped aircraft detected during one job cycle of the program.

2. Common Digitizer Data Reduction (COMDIG) Program.

The COMDIG program extracts selected types of data from a CDRECORD program tape, containing various mixtures of six difference Common Digitizer (CD) message types received by the HCS, and prints these data in prescribed formats.

3. Common Digitizer Record (CD RECORD).

The CD RECORD program provides the capability to record on magnetic tape, CD data as received over the Data Receiver Group (DRG)/HCS interface. The CD RECORD program is run on the HCS.

4. Quick Analysis of Radar Sites (QARS) Program.

The QARS programs is divided into two sections: (1) Radar System Interface Verification, and (2) Radar Data Analysis Summary routine which analyzes the beacon tracks.

a. Radar System Interface Verification.

The following applicable parameters are supplied:

1. Site identification.
2. Beacon percentages.
  - (a) Radar reinforced percentage
  - (b) Mode 3/A validation percentage
  - (c) Mode C validation percentage
  - (d) Mode 2 validation percentage
3. Status summary - provides the status of the primary and secondary radars, and the CD.

b. Radar Data Analysis Summary.

The following parameters are supplied:

1. Adapted radar site name.
2. Video - The receiver videos used for the CD input.
  - (a) Beacon (BCN)

- (b) Moving Target Indicator (MTI)
  - (c) Normal (NML)
  - (d) Combined MTI and Normal video (SCH)
3. Scans -
    - (a) Beacon - total number of antenna revolutions for the period of time the beacon return was tracked.
    - (b) Surveillance - will vary according to a target's range and elevation.
  4. Blip/Scan - The percentage ratio of the number of times a target was detected (BLIP) to the number of times it could have been detected (SCAN).
  5. Radar Reinforced (R/R) - Ratio of number of beacon messages with the reinforced bit set to the total number of beacon messages received.
  6. Collimation (COLL) - The collimation percentage for NML and MTI video.
  7. Beacon split -
    - (a) Azimuth Split (ASPLT)
    - (b) Range Split (RSPLT)
  8. False Beacon (FALSE-BCN) -
    - (a) Ring-a-round (RAR)
    - (b) Reflections (REF)
    - (c) Code zero percentage (ZER)
  9. Code Reliability -
    - (a) Mode 3/A reliability percentage (M3REL)
    - (b) Mode 3/A validity (M3VAL)
    - (c) Mode C reliability percentage (MCREL)
    - (d) Mode C validity (MCVAL)
  10. Range - Beacon track start and stop histories.
  11. Azimuth (AZ) - Beacon track start and stop histories.
  12. Altitude (ALT) - Beacon track start and stop histories.
  13. Deviation (DEV) - Mean difference of the predicted versus the actual position of a track.
  14. Collimation Distribution - Variations of the closest surveillance return relative to the beacon return that was being tracked.

15. Permanent Echo (PE) Verification - Range of the adapted PEs in whole and eighths of a mile, together with the mean error in whole and tenths of Azimuth Change Pulses (ACP).
16. The mean predicted versus actual position of all the tracks for the site.

5. Range, Azimuth, Radar Reinforced Evaluator (RARRE) Program.

The RARRE program provides the capability to retrieve, sort, and print target primary and secondary (beacon) radar information pertaining to all Mode 3/A beacon equipped aircraft detected by any number of radar sites. These data are received from a CD RECORD format tape and run on the HCS.

APPENDIX C  
TEST FORMS

TEST MISSION LOG  
TYPE V/VI  
FGAR OT&E OPERATIONAL TEST

Date: \_\_\_\_\_

Test Number: \_\_\_\_\_

Test Title: \_\_\_\_\_

Test Location: \_\_\_\_\_

Test Team Members/Participants: (Name/Organization/Phone Number)

\_\_\_\_\_  
\_\_\_\_\_  
\_\_\_\_\_  
\_\_\_\_\_

1. Are there any open items, e.g., deviations from the test procedures, required regression testing, etc.?

\_\_\_\_\_  
\_\_\_\_\_  
\_\_\_\_\_  
\_\_\_\_\_  
\_\_\_\_\_  
\_\_\_\_\_

(Use additional sheets, if necessary)

2. The test objective(s) are listed in the appropriate paragraph of Appendix A, of the Test Procedures document.
3. The equipment configuration is described in the appropriate paragraph of Appendix A, of the Test Procedures document.

\_\_\_\_\_  
Test Director (Name, Title, Organization)

FGAR-6/V





