

INVESTIGATION OF THE FEASIBILITY OF
DEVELOPING LOW PERMEABILITY POLYMERIC FILMS

by
J. T. Hoggatt

THE BOEING COMPANY
Aerospace Group
Seattle, Washington

Prepared for
NATIONAL AERONAUTICS AND SPACE ADMINISTRATION

NASA Lewis Research Center
Contract NAS 3-13326
R. F. Lark, Project Manager

19960223 039

DTIC QUALITY INSPECTED 1

DISTRIBUTION STATEMENT A

Approved for public release;
Distribution Unlimited

PLASTEC 17088

1. Report No. NASA CR-120892	2. Government Accession No.	3. Recipient's Catalog No.	
4. Title and Subtitle Investigation of the Feasibility of Developing Low-Permeability Polymeric Films		5. Report Date December 1971	
		6. Performing Organization Code ASG 2-5540	
7. Author(s) J. T. Hoggatt		8. Performing Organization Report No.	
		10. Work Unit No.	
9. Performing Organization Name and Address The Boeing Company Seattle, Washington		11. Contract or Grant No. NAS 3-13326	
		13. Type of Report and Period Covered Contractor Report	
12. Sponsoring Agency Name and Address National Aeronautics and Space Administration Washington, D.C. 20546		14. Sponsoring Agency Code	
		15. Supplementary Notes Project Manager, R. F. Lark, Materials and Structures Division, NASA Lewis Research Center Cleveland, Ohio	
16. Abstract The objective of this program was to determine the feasibility of reducing the gas permeability rate of Mylar and Kapton films without drastically effecting their flexibility characteristics at cryogenic temperatures. This feasibility was established using a concept of diffusion bonding two layers of metallized films together forming a film-metal-film sandwich laminate. The permeability of Kapton film to gaseous helium was reduced from a nominal 10^{-9} cc - mm/cm ² sec. cm Hg to 10^{-13} cc - mm/cm ² - sec. cm Hg with some values as low as 10^{-15} cc - mm/cm ² - sec - cm Hg being obtained. Similar reductions occurred in the liquid hydrogen permeability at -252°C (-423°F). In the course of the program the permeability, flexibility and bond strength of plain, metallized and diffusion bond film were determined at +25°C (+70°F), -195°C (-320°F) and -252°C (-423°F). The cryogenic flexibility of Kapton film was reduced slightly due to the metallization process but no additional loss in flexibility resulted from the diffusion bonding process.			
17. Key Words (Suggested by Author(s)) Cryogenics Permeability Polymeric Films Mylar Film Metallized Films Kapton Film Diffusion Bonding		18. Distribution Statement Unclassified - Unlimited	
19. Security Classif. (of this report) Unclassified	20. Security Classif. (of this page) Unclassified	21. No. of Pages 90	22. Price* \$3.00

* For sale by the National Technical Information Service, Springfield, Virginia 22151

FOREWORD

This report was prepared by The Boeing Company, Aerospace Group, under NASA Contract NAS 3-13326. "Investigation of the Feasibility of Developing Low-Permeability Polymeric Films". The work was sponsored and managed by the National Aeronautics and Space Administration, Lewis Research Center, Materials & Structures Division, Cleveland, Ohio, with Mr. R. F. Lark, Project Manager.

The technical performance period of this program was from April 1, 1970 to September 30, 1971. The report was submitted for approval and publication November 10, 1971.

Performance of this contract was under the direction of the Materials and Processes Organization, Aerospace Group, The Boeing Company. Mr. P. B. Kennedy was Program Manager, and Mr. J. T. Hoggatt, Program Technical Leader. Major participants in the program include:

Processing Studies	Dr. A. L. Schy
Characterization:	A. D. VonVolkli
Cryogenic Testing:	C. C. Mahnken
	G. E. Vermilion

Table of Contents

	Page
Foreword	i
Table of Contents	ii
List of Figures	iii
List of Tables	v
1.0 INTRODUCTION	1
2.0 SUMMARY	3
3.0 TECHNICAL PROGRAM	4
3.1 Film Characterization	4
3.1.1 Permeability Testing	4
3.1.2 Flexibility Tests	26
3.1.3 Bond Strength	31
3.1.4 Inter-ply Inflation Tests	41
3.2 Preliminary Coating Evaluation	47
3.2.1 Material Selection	47
3.2.2 Permeability Testing	54
3.2.3 Flexibility Tests	62
3.2.4 Bond Strength	67
3.3 Advanced Coating Evaluation	74
3.3.1 Material Selection	74
3.3.2 Permeability Testing	75
3.3.3 Flexibility Tests	79
3.3.4 Bond Strength	79
3.3.5 Inter-ply Inflation Tests	79
4.0 CONCLUSIONS AND RECOMMENDATIONS	83
5.0 REFERENCES	84
6.0 DISTRIBUTION LIST	85

LIST OF FIGURES

<u>Figure</u>	<u>Title</u>	<u>Page</u>
1	Permeability Fixture with Backing Plate	6
2	Permeability Test System	7
3	Gas Volume Measurement by Water Displacement	9
4	Test Set-up	10
5	Average Permeability - 0.25 Mil (0.00635 MM) Film	11
6	Average Permeability - 0.50 Mil (0.0127 MM) Film	12
7	Helium Permeability - 0.25 Mil (0.00635 MM) Unstressed Mylar	16
8	Helium Permeability - 0.25 Mil (0.00635 MM) Stressed Mylar	17
9	Helium Permeability - 0.50-Mil (0.0127 MM) Unstressed Mylar	18
10	Helium Permeability - 0.50 Mil (0.0127 MM) Stressed Mylar	19
11	Helium Permeability - 0.25 Mil (0.00635 MM) Unstressed Kapton	20
12	Helium Permeability - 0.25 Mil (0.00635 MM) Stressed Kapton	21
13	Helium Permeability - 0.50 Mil (0.0127 MM) Unstressed Kapton	22
14	Helium Permeability - 0.50 Mil (0.0127 MM) Stressed Kapton	23
15	Liquid Hydrogen Permeability - 0.25 Mil (0.00635 MM) Films	24
16	Liquid Hydrogen Permeability - 0.50 Mil (0.0127 MM) Films	25
17	Twist-Flex Action	28
18	Joint Concepts	32
19	Interply Inflation Specimen	42
20	Interply Inflation Specimen in Inflated Condition	45
21	Diffusion Bonded Laminate Process	49

LIST OF FIGURES

<u>Figure</u>	<u>Title</u>	<u>Page</u>
22	Vacuum Deposited Gold on Kapton Film - After Diffusion Bonding	51
23	Diffusion Bonded Gold-Kapton Film	52
24	Sputtered Gold Coating on 1/4 Mil Kapton Film - Cross-Section View (6000X)	53
25	Relationship of Film Thickness to Twist-Flex Cyclic Life at -320°F	68

LIST OF TABLES

<u>Table</u>	<u>Title</u>	<u>Page</u>
I	Average Specific Permeability Rates of Mylar and Kapton Film	13
II	Permeability Test Measurements	14
III	Twist-Flex Testing Results	29
IV	Bond Strength Tensile Tests - Butt Joint .25 Mil (.00635 mm) Kapton	33
V	Bond Strength Tensile Tests - Butt Joint .50 Mil (.0127 mm) Kapton	34
VI	Bond Strength Tensile Tests - Butt Joint .25 Mil (.00635 mm) Mylar	35
VII	Bond Strength Tensile Tests - Butt Joint .50 Mil (.0127 mm) Mylar	36
VIII	Bond Strength Tensile Tests - Lap Joint .25 Mil (.00635 mm) Kapton	37
IX	Bond Strength Tensile Tests - Lap Joint .50 Mil (.0127 mm) Kapton	38
X	Bond Strength Tensile Tests - Lap Joint .25 Mil (.00635 mm) Mylar	39
XI	Bond Strength Tensile Tests - Lap Joint .5 Mil (.0127 mm) Mylar	40
XII	Interply Inflation Tests at -320°F (-195°C)	43
XIII	Interply Inflation Tests at -423°F (-252°C)	44
XIV	Proposed Coatings	48
XV	Specific Permeability Rates of Plain and Metalized Films	55
XVI	Summary - Average Specific Permeability Rates at +70°F (21°C)	59
XVII	Twist-Flex Results at -320°F (-195°C)	63
XVIII	Bond Strength Tensile Tests - +70°F (21°C)	69
XIX	Specific Permeability Rates of Diffusion Bonded Kapton Film Laminates	76
XX	Twist-Flex Test Results @-423°F (-252°C)	80
XXI	Bond Strength Results at -423°F (-252°C) - Butt Joint	81
XXII	Bond Strength Results at -423°F (-252°C) - Lap Joint	82

1.0 INTRODUCTION AND BACKGROUND

This program was sponsored to investigate the feasibility of a new laminating and coating concept for reducing the gaseous permeability of select polymeric films for cryogenic service.

Polymeric films, namely Mylar and Kapton, have demonstrated good potential as expulsion bladder materials for cryogenic fluid containment (References 1, 2, 3 and 7). One parameter hindering the successful application of these materials in cryogenic bladders is the diffusion of hydrogen and helium through the film causing interply inflation of the bladder. An inflated bladder lowers both fill and expulsion efficiency and in extreme cases renders the bladder completely inoperative. Although interply inflation can result either from leakage or diffusion, permeability tests on unflexed 2-ply material samples have demonstrated interply inflation can occur as a result of diffusion alone.

Over the years Boeing and others have attempted to reduce the permeability of film by techniques such as vacuum deposition, chemical vapor deposition, electroless plating and laminating metallic foils to or between films. Each of these techniques has been successful to varying degrees in reducing the gaseous permeability, but generally the coating thickness required to provide low permeability resulted in poor flexibility at cryogenic temperatures.

In 1969 Boeing began development of a technique for obtaining low permeability film that retains good flexibility characteristics at cryogenic temperatures. The development approach taken at Boeing was to metallize two plies of polymer film and then to diffusion bond the two plies together at the metal-coated surfaces. The thin metallic coating, 5,000A to 10,000A, can be deposited using any convenient process (vacuum deposition, sputtering, electroless plating, etc.). The coating on the basic film may or may not be impermeable to gases, but when the two plies are diffusion bonded together, the resulting metal flow and the statistical distribution of holes in each film seals the pinholes forming a relatively impermeable film-metal-film laminate (Reference 4). The resulting metallic layer is very thin and flexible.

The diffusion bonded laminate concept has several unique advantages which are important in a cryogenic propellant system: (1) permeability is reduced as a result of both metal flow during the diffusion process and the fact that the pinhole in one metal film is covered by the other metal film; (2) the metal coating is at the neutral axis of the "sandwich" so that stressing of the metal in folds during flexing of a bladder will be reduced, thus prolonging integrity; (3) the metal coating will be protected from abrasion damage during subsequent bladder fabrication and assembly; and (4) the metal coating cannot peel or flake during stress, thereby preventing the propellant from becoming contaminated during expulsion. This latter point is an important factor in obtaining a reliable propulsion system. Due to the high processing temperature requirements imposed by the diffusion bonding process, the laminated concept could only be utilized with Kapton film. In the program, the laminated Kapton films were compared to conventional metallized Kapton and Mylar films to provide data control.

2.0 SUMMARY

The objective of this program was to determine the feasibility of reducing the gas permeability rate of Mylar and Kapton films without drastically affecting their flexibility characteristics at cryogenic temperatures. This feasibility was established using a concept of diffusion bonding two layers of metallized films together forming a film-metal-film sandwich laminate. The permeability of Kapton film to gaseous helium was reduced from a nominal 10^{-9} cc - mm/cm²-sec.-cm Hg to 10^{-13} cc - mm/cm² - sec.-cm Hg with some values as low as 10^{-15} cc - mm/cm² - sec - cm Hg being obtained. Similar reductions occurred in the liquid hydrogen permeability at -252°C (-423°F). In the course of the program the permeability, flexibility and bond strength of plain, metallized and diffusion bond film were determined at +25°C (+70°F), -195°C (-320°F) and -252°C (-423°F). The flexibility of Kapton film was reduced slightly due to the metallization process, but no additional loss in flexibility resulted from the diffusion bonding process.

Bond strengths of the diffusion bonded laminates were as good as those obtained with the plain Kapton film.

3.0 TEST PROGRAM

The technical phase of this program was divided into three principal tasks. Task I consisted of basic film characterization. Mylar and Kapton film were evaluated for permeability and flexibility to establish a base line for the studies which followed. In Task II ten metallized film concepts were characterized and the three most promising concepts selected for more extensive evaluation in Task III. The details of Task I, II and III are discussed in Sections 3.1, 3.2 and 3.3 respectively.

3.1 Film Characterization

The objective of this task was to characterize each lot of Mylar and Kapton film used in the program. The data then served as a basis for comparison in assessing the effects of metallizing and laminating on reducing permeability. The material selection was limited to two basic materials: type C Mylar film and Kapton polyimide film. Both materials were evaluated in 0.00635 mm (1/4 mil) and 0.0127 mm (1/2 mil) thicknesses. The film selection was limited to these materials since previous programs (References 1-3 and 7) have shown Mylar and Kapton to be the best materials for cryogenic expulsion bladders.

Film characterization consisted of measuring the permeability to helium gas at 21°C (+70°F), -195°C (-320°F) and -252°C (-423°) and to liquid hydrogen at -252°C (-423°F). Determinations were made in both the stressed and unstressed condition. In addition tests for film flexibility bond strength and interply inflation characteristics were made. Details on each of the characterization tests are given below.

3.1.1 Permeability Measurements

As stated above helium permeability determinations were made on each film at +21°C, -195°C and -252°C in both the unstressed and stressed (20% of ultimate strength) conditions. Measurements were also made on the liquid hydrogen permeability rate at -252°C under similar stressed and unstressed conditions.

The test specimen had an overall diameter of 24.13 cm (9.5 inches) with .953 cm (.375 inches) diameter holes on a 10.16 cm (4") radius for mounting bolts. The effective test area was 17.78 cm (7.0") in diameter for an area of 248.16 cm² (38.47 in²). The specimen was installed in the fixture shown in Figure 1 for test.

For the helium permeation tests in the unstressed condition the specimen was pressurized with gaseous helium to a pressure differential (ΔP) of 51.71 mm Hg (1 psi) across the sample. The sample was restrained with a porous backing plate (Figure 1) to maintain a state of zero stress. The cryostat was filled with the appropriate cryogenic (liquid nitrogen for the -195°C tests and liquid hydrogen for the -252°C tests) to maintain the sample at the desired temperature. The test gas passed through coils submerged in the cryostat prior to contacting the specimen to bring the gas to the desired test temperature (see Figure 2).

The entire system was allowed to come to equilibrium prior to making any measurements. This required about 30-45 minutes. The quantity of gas permeating the film sample was then measured with a helium mass spectrometer at standard conditions.

For the gas permeability determination of the film in the stressed condition (20%) the same procedures were utilized except the backing plate was removed from the permeability fixture and the Δp was increased to 103 mm/Hg (1.5 psi) for the 1/2 mil film and held at 51.71 mm Hg (1 psi) for the 1/2 mil film. This in effect stressed the film to 20% of ultimate in the center section. The quantity of pressure to apply to the film was determined by making a plot of material deflection versus pressure (at room temperature) and calculating the stress on the film.

$$\text{Stress} = \frac{(\text{Pressure, psi}) (\text{Radius of Curvature})}{(2) (\text{Film Thickness})}$$

The pressure at which the film stress was approximately 20% of ultimate was then determined by interpolation.

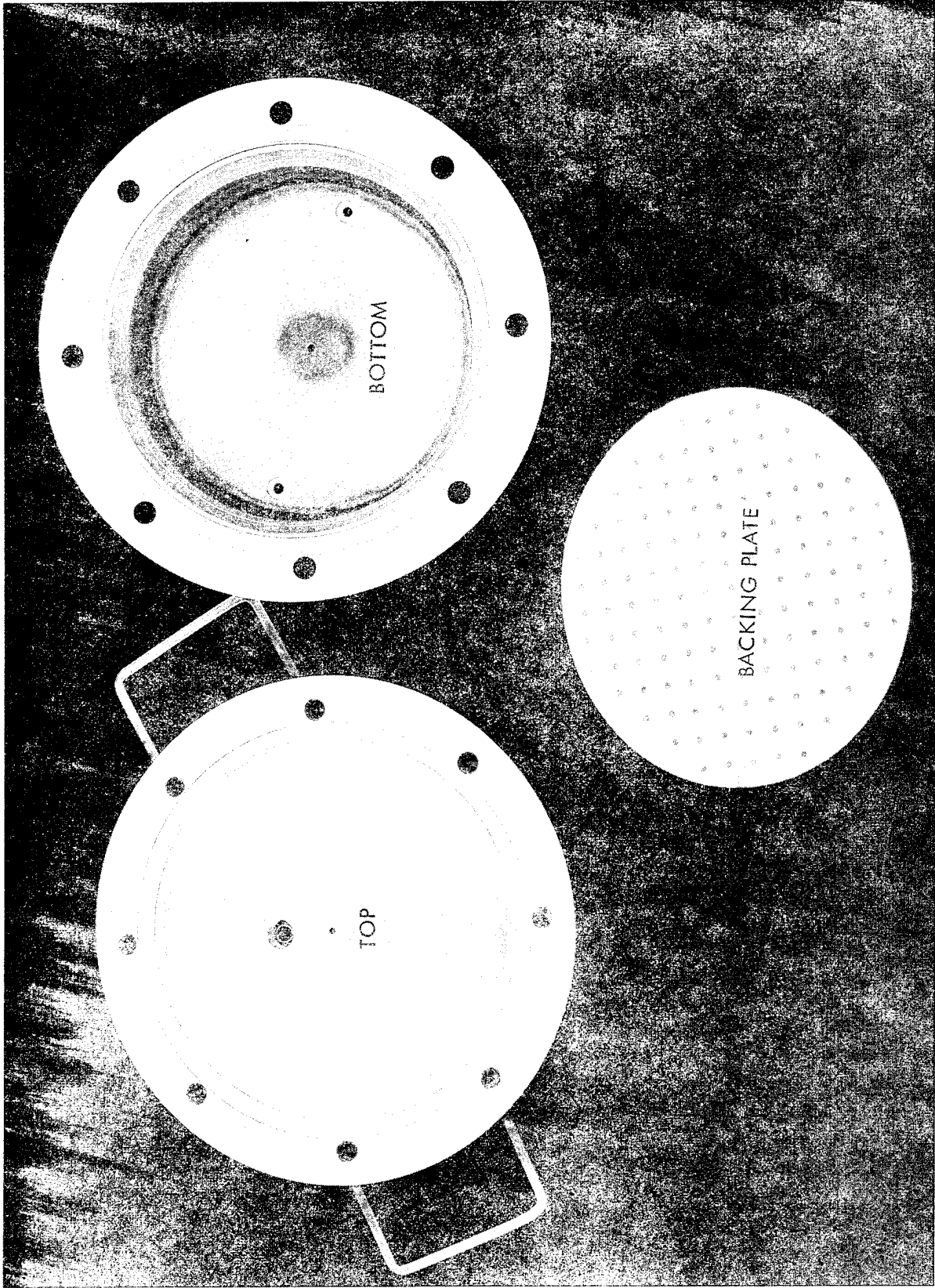

FIGURE 1 PERMEABILITY FIXTURE WITH BACKING PLATE

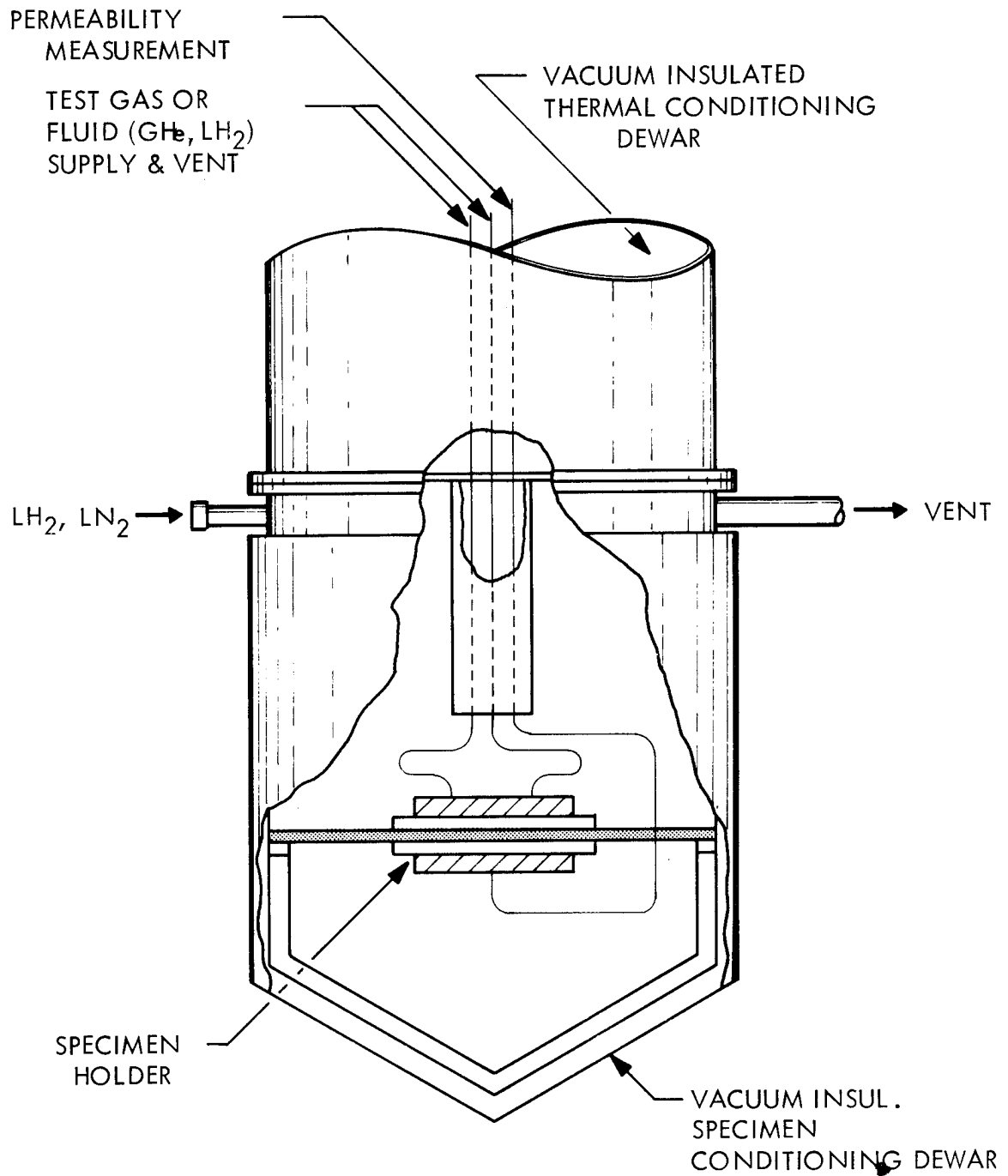

FIGURE 2 PERMEABILITY TEST SYSTEM

Liquid hydrogen permeability rate of the films was determined using the same basic equipment and procedures used for the helium tests. Liquid hydrogen was placed on the inlet side of the sample and in the cryostat. The quantity of hydrogen diffusing through sample was measured with a platinum foil hydrogen analyzer (Boeing built and patented).

As a general procedure to minimize data scatter and provide maximum data correlation, one sample was subjected to all four permeability tests (R. T., -195°C , -252°C , and LH_2) without removing it from the test fixture or making any other alterations which may influence the permeability readings. In a few instances, due to specimen leakage, a malfunction or a failure in the seal, a new specimen had to be run. In all cases the system was completely purged after each data point was obtained.

In a few instances the permeability rates exceeded 10^{-4} cc/sec, the capability of the detection equipment, flooding the system. When this occurred the permeability was measured by water displacement using the technique shown in Figure 3. The set-up shown eliminates any back pressure and influences due to water head.

Both the helium mass spectrometer and the hydrogen gauge were calibrated at regular intervals. The helium detector was calibrated with a standard leak (Veeco - Model SC-4) and the hydrogen gauge was calibrated with a Faraday cell. The complete test set-up is shown in Figure 4.

The averages of the permeability data are plotted in Figures 5 and 6 and Table I. Detailed data are contained in Table II and Figures 7 - 16. In Table I the average permeabilities have been converted to standard units. These data compare favorably with other data reported in the literature and with data reported by duPont in their film brochures.

Approximately twelve attempts were made to conduct permeability readings on stressed 1/4-mil Mylar film at cryogenic temperatures without success. The film ruptured with as little as 10 mm Hg (0.2 psi) pressure differential making it impossible to obtain a reading. By comparison the 1/4-mil Kapton

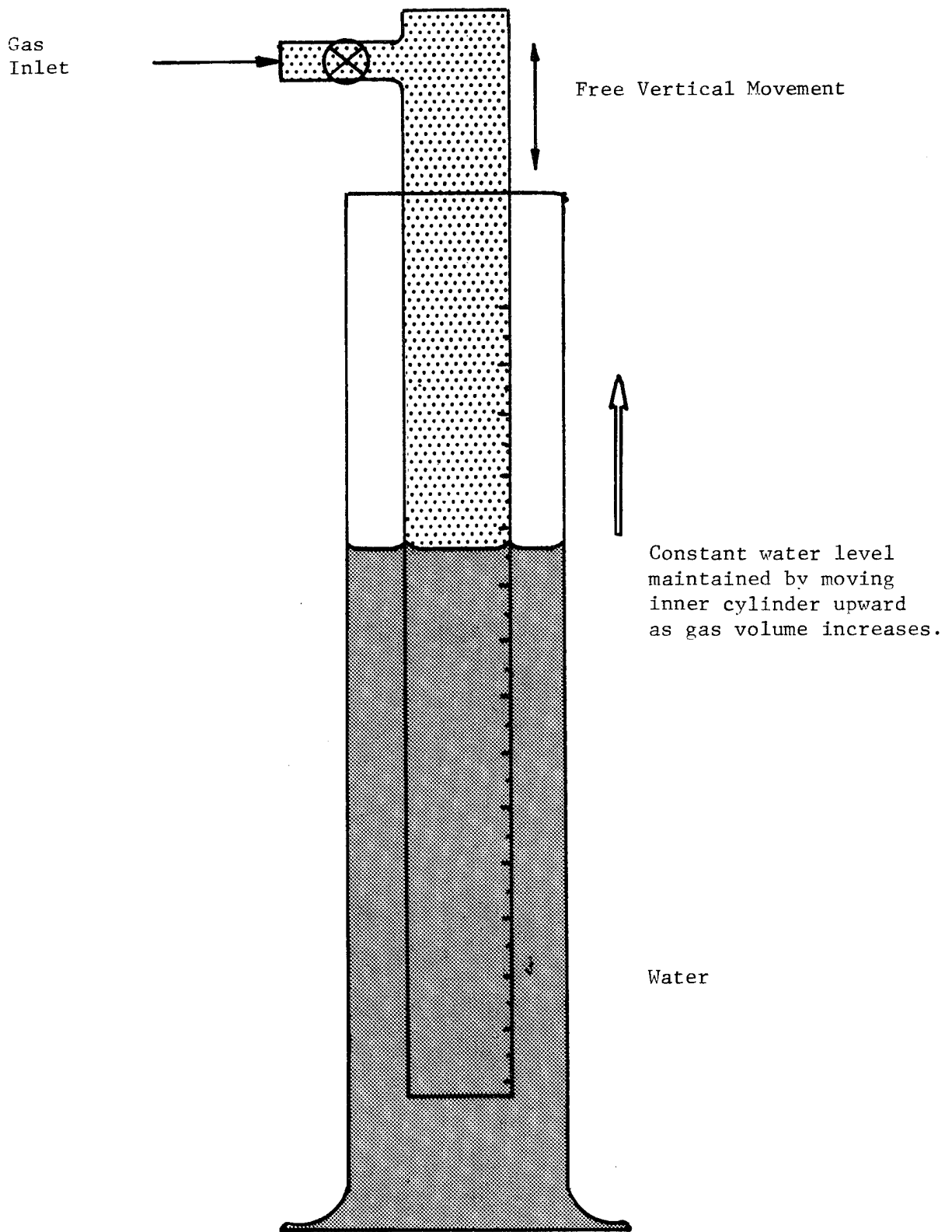

FIGURE 3 GAS VOLUME MEASUREMENT BY WATER DISPLACEMENT

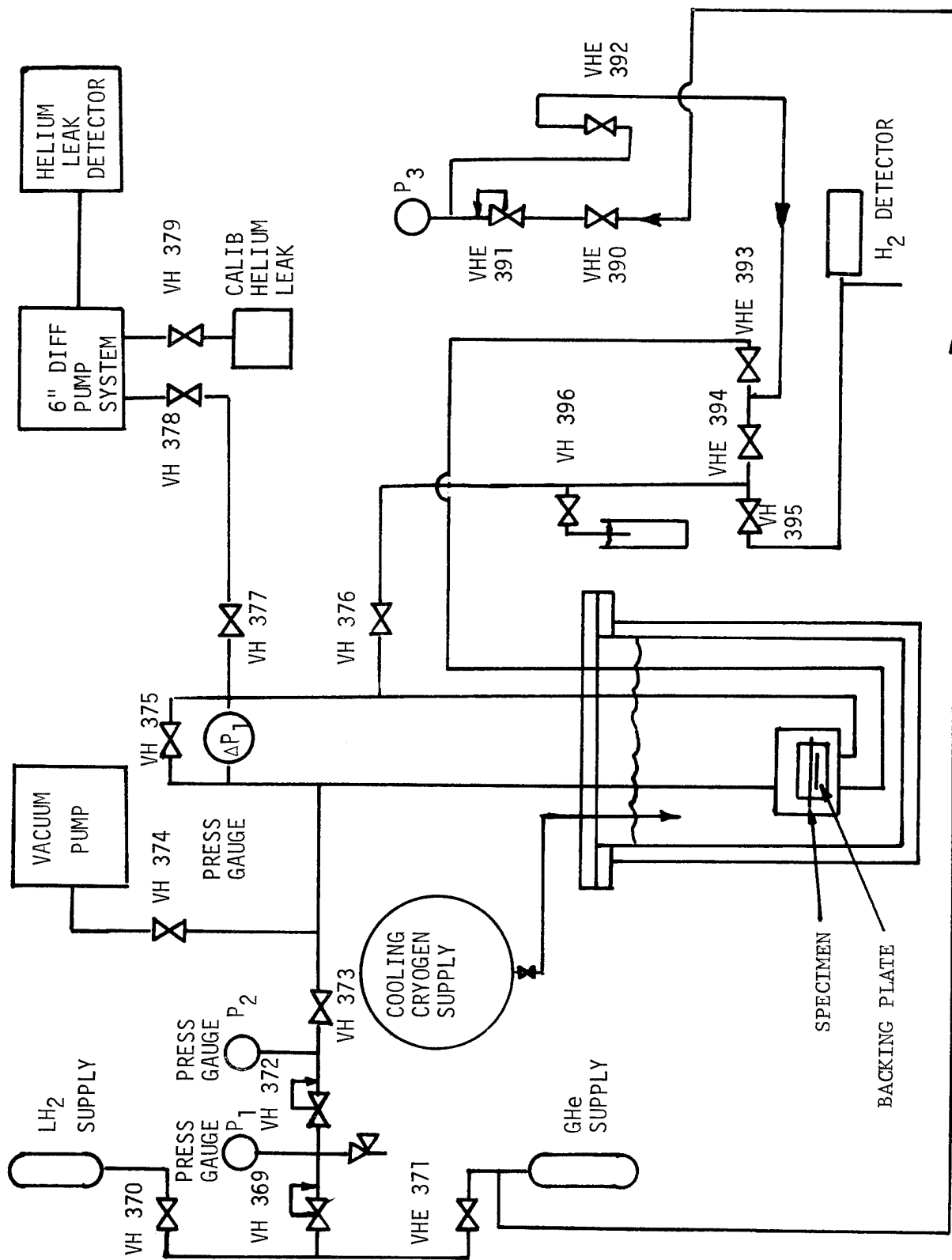

FIGURE 4 Schematic of Permeability Test Set-up

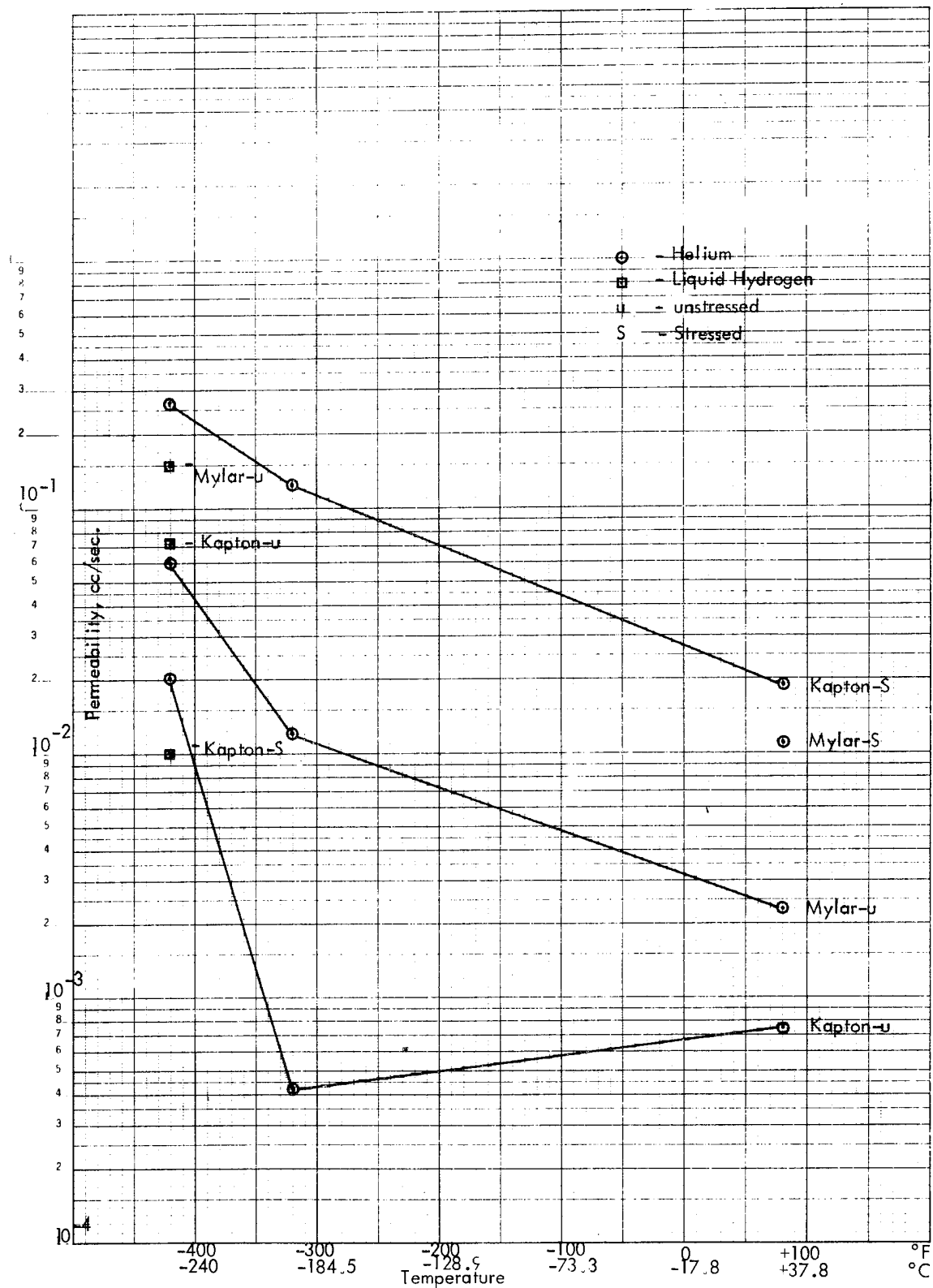

FIGURE 5 - AVERAGE PERMEABILITY - 0.25 MIL (0.00635 MM) FILMS

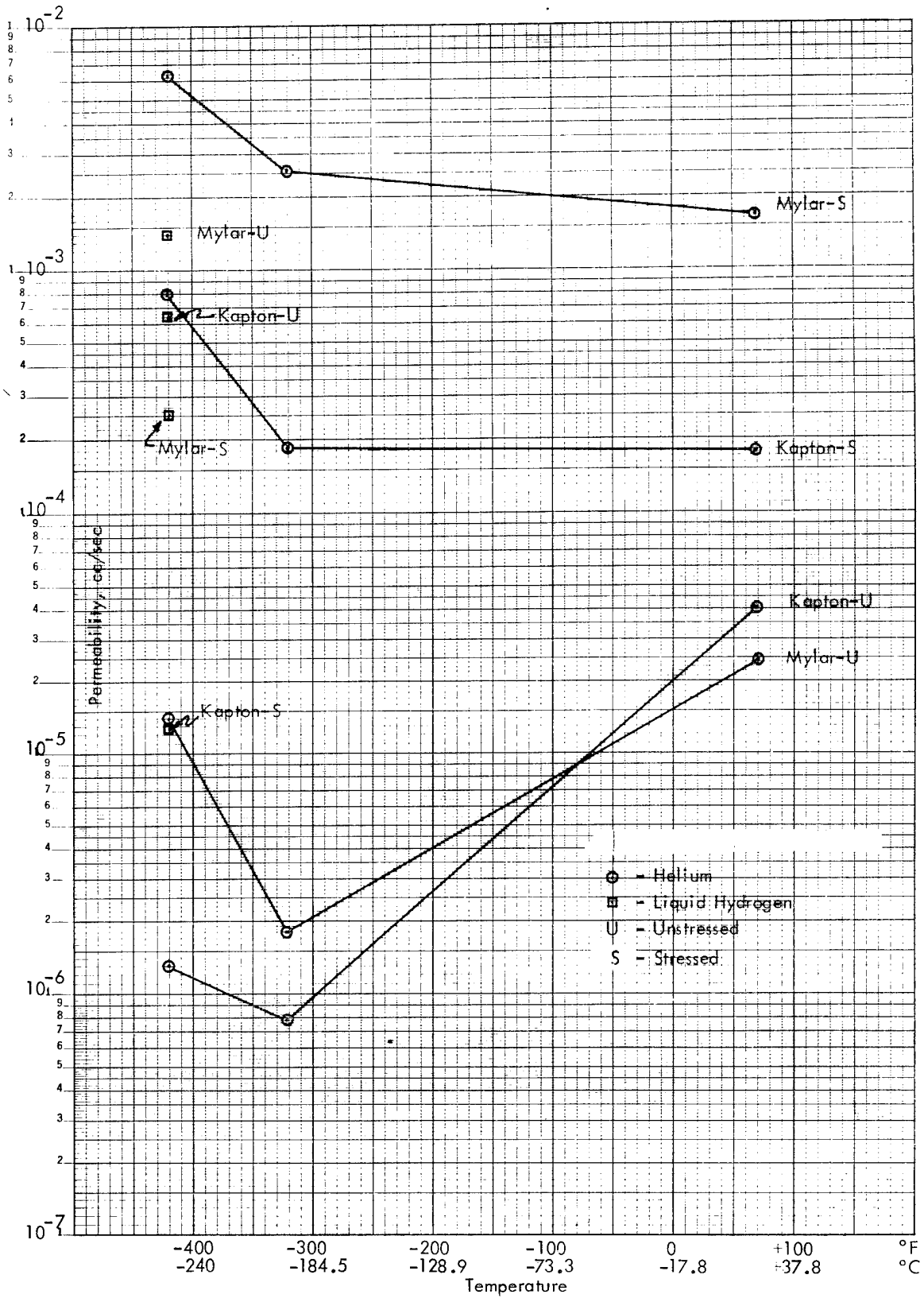

FIGURE 6- AVERAGE PERMEABILITY - 0.50 MIL (0.0127 MM) FILMS

TABLE I AVERAGE SPECIFIC PERMEABILITY RATES OF MYLAR AND KAPTON FILM

Material	Specific Permeability Rates									
	10^3 Std. cc-mil/100 in ² .24 hrs·Atm					10^{-9} Std. cc-mm/cm ² ·sec·cm Hg				
	+21°C	-195°C	GHe	GHe	LH ₂	-252°C	+21°C	-195°C	-252°C	-252°C
Fluid	GHe	GHe	GHe	GHe	LH ₂	LH ₂	GHe	LH ₂	LH ₂	LH ₂
1. Mylar, .25 mil (.00635 mm) Unstressed	1.91	10	49.8	125	11.4	60	54.8	298	750	
2. Mylar, .25 mil (.00635 mm) Stressed	9.13	-	-	-	0.238	-	-	-	-	-
3. Mylar, .5 mil (.0127 mm) Unstressed	0.0396	0.0033	0.0231	2.310	16.8	0.018	0.238	0.138	13.90	
4. Mylar, .5 mil (.0127 mm) Stressed	2.8	4.29	10.2	0.413	16.8	25.7	16.8	61	2.48	
5. Kapton, .25 mil (.00635 mm) Unstressed	0.622	0.349	16.5	58.0	3.73	2.09	3.73	99	324	
6. Kapton, .25 mil (.00635 mm) Stressed	15.8	104	216	8.3	95	624	95	1300	50	
7. Kapton, .5 mil (.0127 mm) Unstressed	0.066	0.00127	0.00215	1.060	0.396	0.00762	0.396	0.0129	6.35	
8. Kapton, .5 mil (.0127 mm) Stressed	0.289	0.305	1.32	0.0215	1.73	1.83	1.73	7.92	0.129	
9. DuPont Data - Mylar - 1 mil	0.167	-	-	-	1	-	-	-	-	-
10. DuPont Data - Kapton - 1 mil	0.415	-	-	-	2.49	-	2.49	-	-	-

TABLE II PERMEABILITY TEST MEASUREMENTS

Film	Thickness, mils (mm)	Specimen Number	Film Stress	ΔP psi (Kg/sq. cm)	Permeability - cc/sec				LH?
					Gaseous Helium		Helium		
					+70°F(+21°C)	-320°F(-195°C)	-423°F(-252°C)	-423°F(-252°C)	
Mylar	.25(.00635)	P1/4M	0	1.0 (.0703)	1.1 x 10 ⁻⁴	1.67 x 10 ⁻²	6.54 x 10 ⁻³	1.46 x 10 ⁻¹	3
		-1	X	→	2.5 x 10 ⁻⁴	2.25 x 10 ⁻²	1.22 x 10 ⁻¹	5.93 x 10 ⁻³	
		-2	X	→	2.11 x 10 ⁻⁴	9.5 x 10 ⁻⁴	2.96 x 10 ⁻³	2.2	
		-3	X	→	8.34 x 10 ⁻³	1.79 x 10 ⁻³	1.35 x 10 ⁻²	2.94 x 10 ⁻¹	
		-4	X	→	4.6 x 10 ⁻⁴	1.78 x 10 ⁻²	1.54 x 10 ⁻¹	→	
		-5	X	→	2.27 x 10 ⁻³	→	→	→	
		-6	X	→	6.33 x 10 ⁻²	→	→	→	
		-7	X	→	1.69 x 10 ⁻⁴	→	→	→	
		-8	X	→	1.26 x 10 ⁻⁴	→	→	→	
		-9	X	→	5.56 x 10 ⁻⁴	→	→	→	
Mylar	.50(.0127)	P1/2M	0	1.0 (.0703)	5.1 x 10 ⁻⁷	1.38 x 10 ⁻⁶	3.58 x 10 ⁻⁶	8.2 x 10 ⁻⁴	1
		-1	X	→	2.24 x 10 ⁻⁶	4.09 x 10 ⁻⁷	1.96 x 10 ⁻⁶	6.5 x 10 ⁻⁴	
		-2	X	→	7.0 x 10 ⁻⁵	2.91 x 10 ⁻⁶	7.95 x 10 ⁻⁵	→	
		-3	X	→	1.86 x 10 ⁻⁵	7.0 x 10 ⁻⁷	9.55 x 10 ⁻⁷	2.35 x 10 ⁻⁴	
		-4	X	→	5.59 x 10 ⁻⁵	1.85 x 10 ⁻⁶	1.35 x 10 ⁻⁶	4.0 x 10 ⁻³	
		-5	X	→	2.47 x 10 ⁻⁶	→	→	→	
		-6	X	→	3.76 x 10 ⁻⁵	→	→	→	
Mylar	.50(.0127)	P1/2M	0	1.0 (.0703)	2.07 x 10 ⁻⁵	2.32 x 10 ⁻⁶	1.04 x 10 ⁻⁶	→	1
		-1	X	→	9.55 x 10 ⁻⁶	8.1 x 10 ⁻⁷	1.52 x 10 ⁻⁶	1.25 x 10 ⁻⁴	
		-2	X	→	3.4 x 10 ⁻⁵	1.94 x 10 ⁻⁶	5.43 x 10 ⁻³	3.27 x 10 ⁻⁵	
		-3	X	→	4.62 x 10 ⁻³	2.36 x 10 ⁻³	→	→	
		-4	X	→	9.75 x 10 ⁻⁴	7.52 x 10 ⁻³	1.0 x 10 ⁻²	1.4 x 10 ⁻⁴	
		-5	X	→	7.0 x 10 ⁻⁴	1.67 x 10 ⁻³	→	→	
		-6	X	→	1.67 x 10 ⁻²	9.0 x 10 ⁻³	→	→	
		-7	X	→	2.42 x 10 ⁻³	1.21 x 10 ⁻³	→	→	
		-8	X	→	→	→	1.03 x 10 ⁻²	1.2 x 10 ⁻⁴	
		-9	X	→	→	→	→	→	

1 Samples tore - unable to obtain readings under stressed conditions.

2 Extra specimens.

3 Excessive leak in specimen.

TABLE II PERMEABILITY TEST MEASUREMENTS (Continued)

Film	Thickness, mils (mm)	Specimen Number	Film Stress		ΔP psi (Kg/sq. cm)	Permeability - cc/sec				LH ₂
			0	20%		Gaseous Helium			-423°F (-252°C)	
						+70°F (+21°C)	-320°F (-195°C)	-423°F (-252°C)		
Kapton	.25(.00635)	P1/4K			1.0 (.0703)	2.78 x 10 ⁻⁴	4.63 x 10 ⁻⁴	2.78 x 10 ⁻³	3.08 x 10 ⁻³	
		-1	X				1.6 x 10 ⁻⁴	3.8 x 10 ⁻⁶	-	
		-2	X				1.18 x 10 ⁻³	6.06 x 10 ⁻⁵	4.66 x 10 ⁻⁵	3.4 x 10 ⁻⁵
		-3	X				1.51 x 10 ⁻³	8.6 x 10 ⁻⁴	7.52 x 10 ⁻²	2.68 x 10 ⁻¹
		-4	X				6.32 x 10 ⁻⁴	1.74 x 10 ⁻⁴	4.65 x 10 ⁻³	5.45 x 10 ⁻³
		-5	X				1.19 x 10 ⁻²	6.7 x 10 ⁻¹	10.5	14.0
		-6		X		1.0 (.0703)	5.33 x 10 ⁻⁴	1.92 x 10 ⁻³	1.63 x 10 ⁻²	3.31 x 10 ⁻³
		-7		X			2.32 x 10 ⁻³	1.2 x 10 ⁻²	-	-
		-8		X			3.5 x 10 ⁻³	5.22 x 10 ⁻³	6.32 x 10 ⁻³	3.38 x 10 ⁻³
		-9		X			6.8 x 10 ⁻²	2.2 x 10 ⁻²	5.6 x 10 ⁻²	2.3 x 10 ⁻²
-10		X		1.0 (.0703)						
Kapton	.50(.0127)	P1/2K			1.0 (.0703)	5.72 x 10 ⁻⁵	7.82 x 10 ⁻⁷	3.35 x 10 ⁻⁷	4.2 x 10 ⁻⁴	
		-1	X			5.06 x 10 ⁻⁵	8.15 x 10 ⁻⁷	2.54 x 10 ⁻⁶	2.8 x 10 ⁻⁵	
		-2	X			3.62 x 10 ⁻⁵	6.2 x 10 ⁻⁷	1.35 x 10 ⁻⁶	1.3 x 10 ⁻³	
		-3	X			1.065 x 10 ⁻⁵	3.6 x 10 ⁻⁷	8.0 x 10 ⁻⁷	1.95 x 10 ⁻⁵	
		-4	X			4.5 x 10 ⁻⁵	1.29 x 10 ⁻⁶	1.48 x 10 ⁻⁶	1.3 x 10 ⁻³	
		-5	X			1.5 (.1055)	7.3 x 10 ⁻⁵	-	-	
		-6		X			3.82 x 10 ⁻⁵	2.58 x 10 ⁻⁶	5.17 x 10 ⁻⁶	3.6 x 10 ⁻⁶
		-7		X			6.5 x 10 ⁻⁵	9.2 x 10 ⁻²	2.0	Tore
		-8		X			1.57 x 10 ⁻⁵	-	-	-
		-9		X			9.81 x 10 ⁻⁵	2.57 x 10 ⁻⁶	>10	>10
		-10		X			1.27 x 10 ⁻³	1.04 x 10 ⁻³	3.65 x 10 ⁻³	5.2 x 10 ⁻⁵
		-11		X			1.39 x 10 ⁻⁴	1.13 x 10 ⁻⁵	2.76 x 10 ⁻⁶	4.0 x 10 ⁻⁶
		-12		X			-	-	1.0	>10
-13		X		1.5 (.1055)						

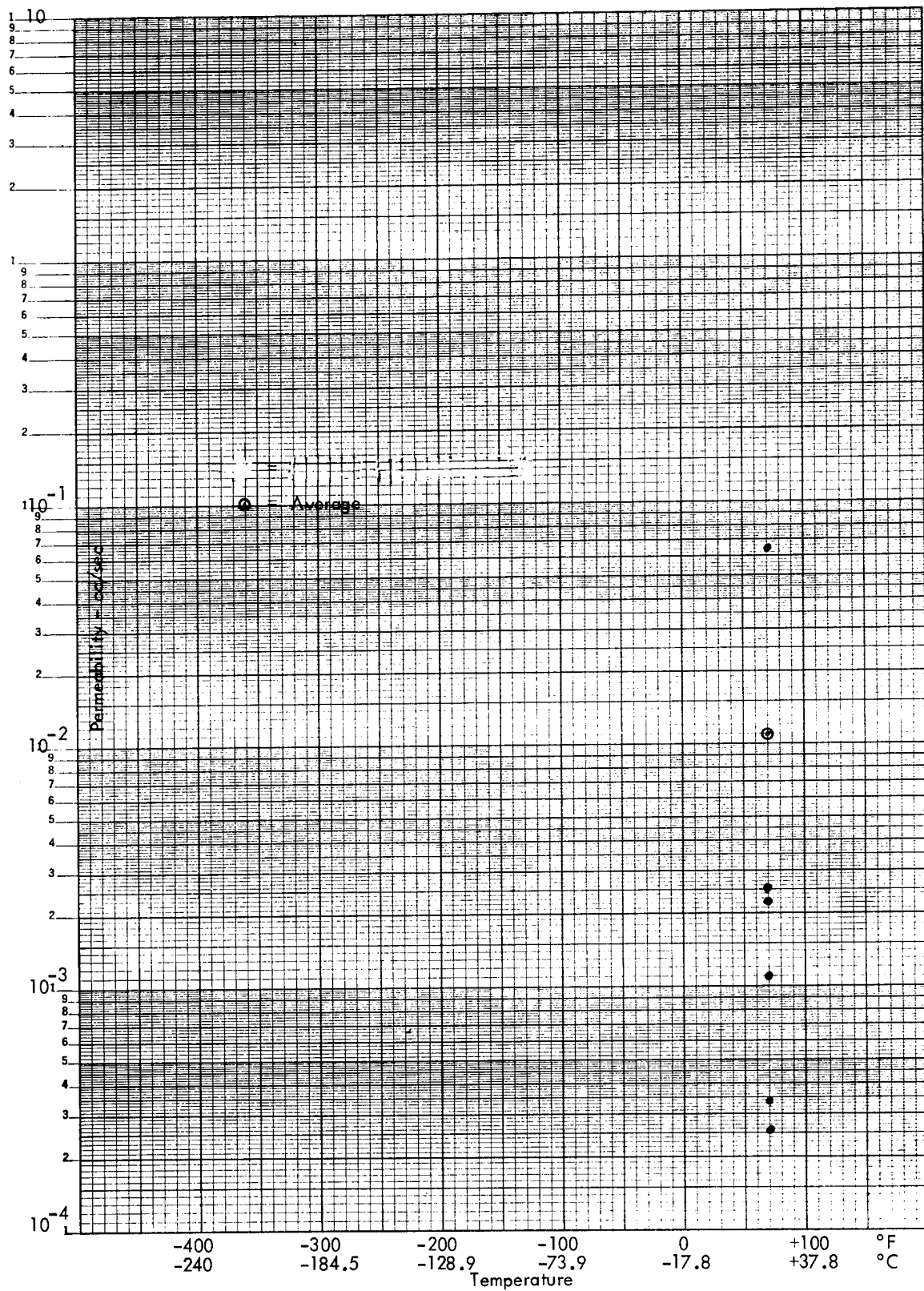

FIGURE 8 - HELIUM PERMEABILITY - 0.25-MIL (0.00635 MM) STRESSED MYLAR

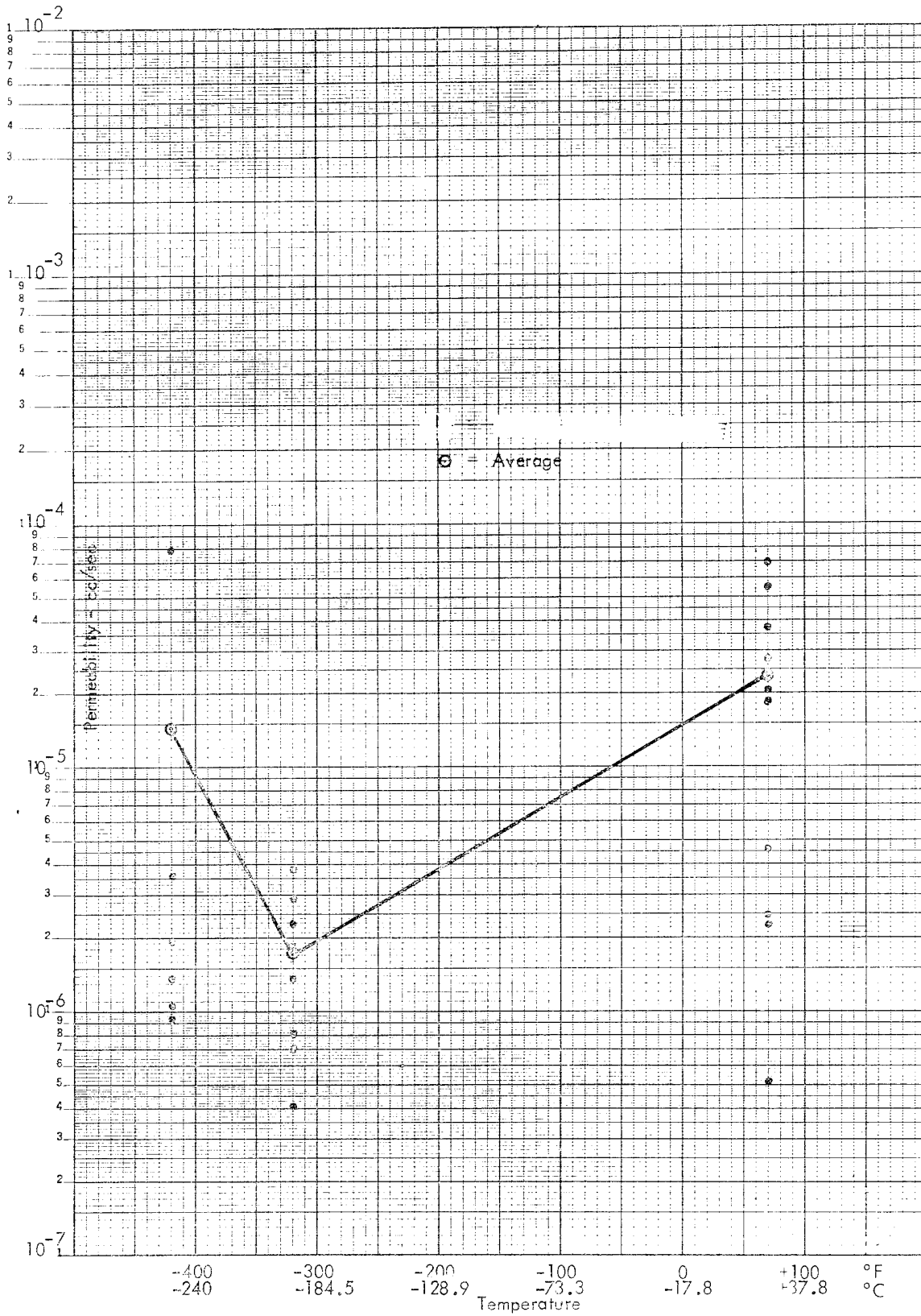

FIGURE 9 - HELIUM PERMEABILITY - 0.50-MIL (0.0127 MM) UNSTRESSED MYLAR

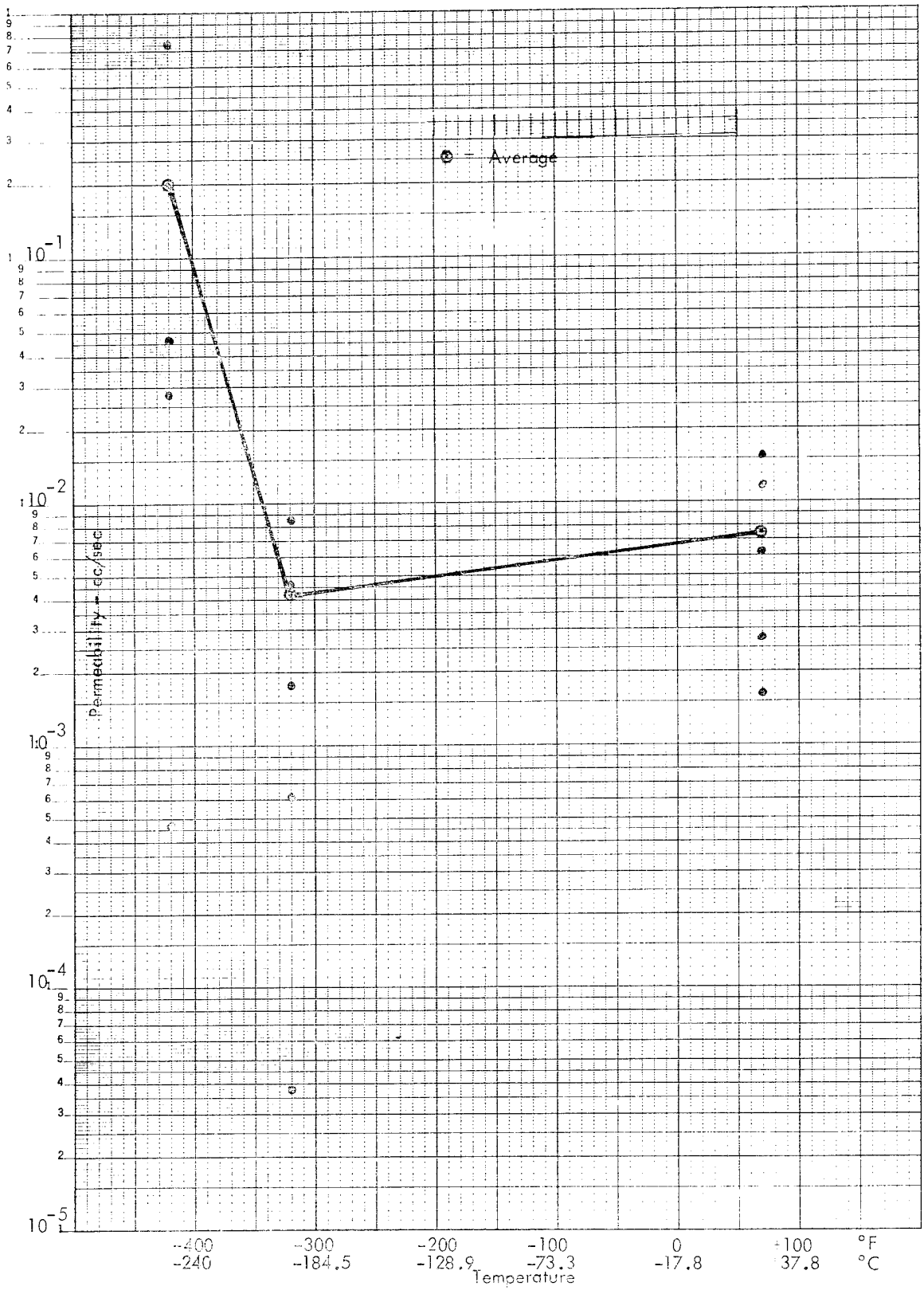

FIGURE 11 - HELIUM PERMEABILITY - 0.25-MIL (0.00635 MM) UNSTRESSED KAPTON

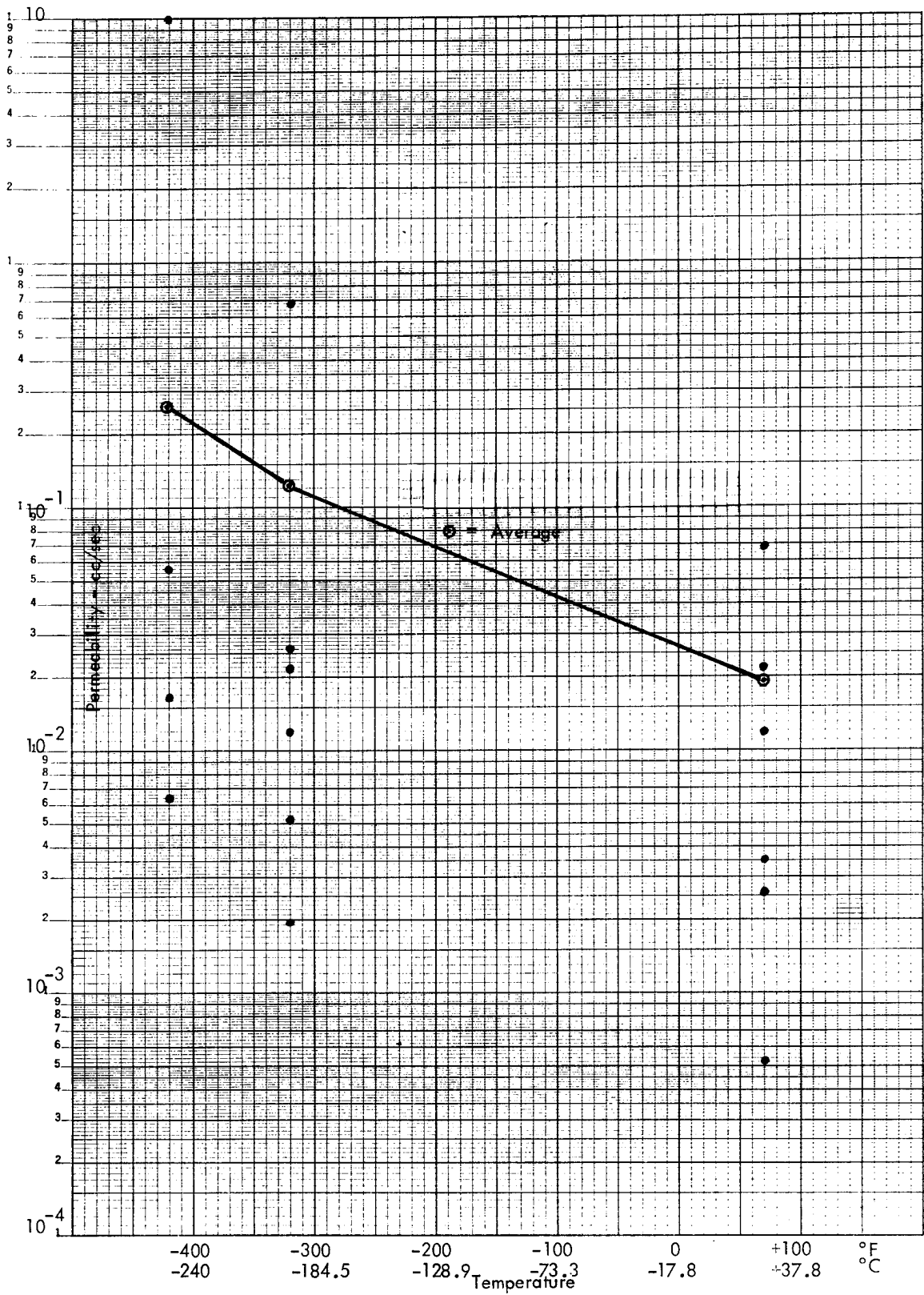



FIGURE 10. Comparison of the measured and calculated magnitudes of the seismic noise.

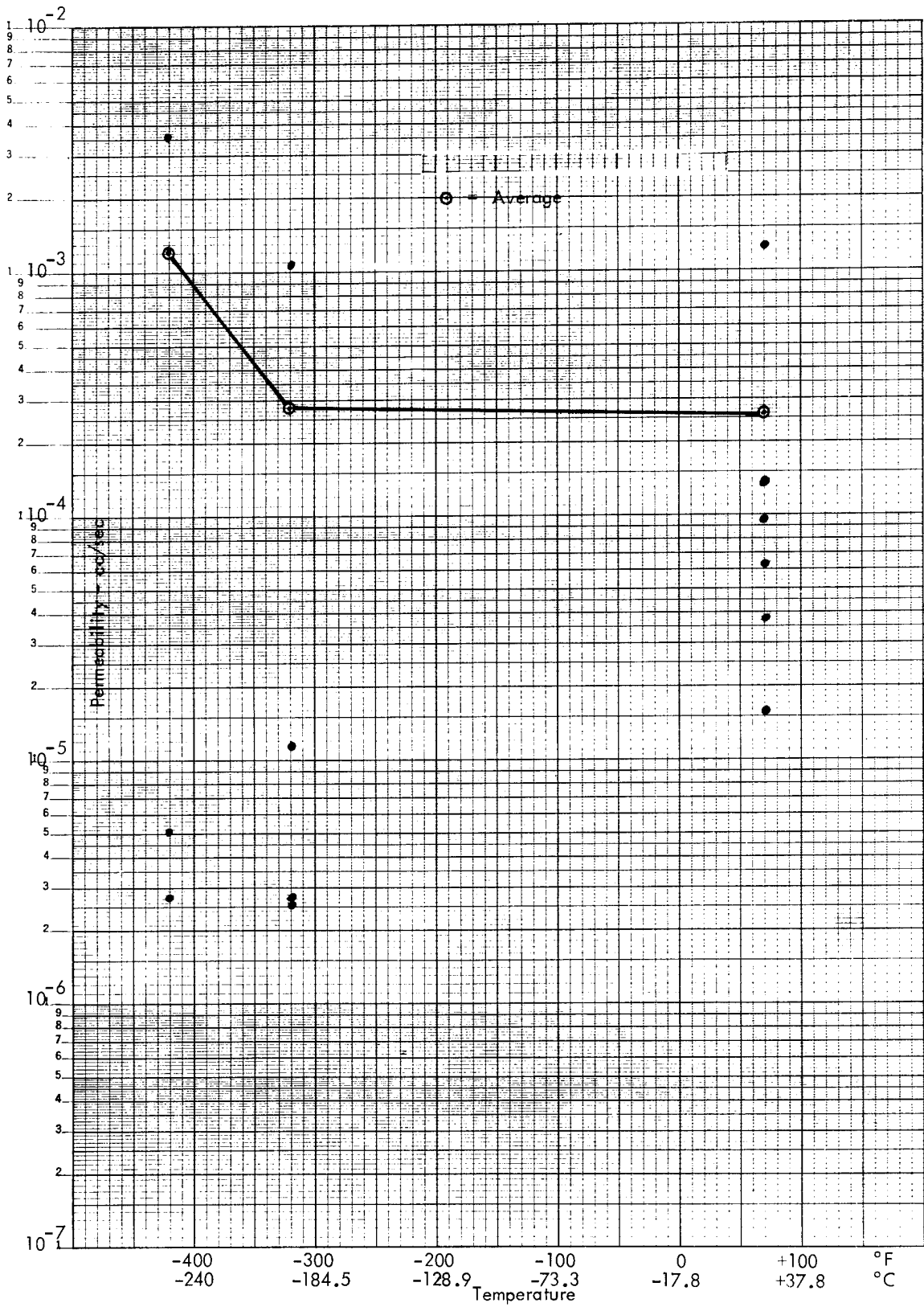

FIGURE 14 - HELIUM PERMEABILITY - 0.50-MIL (0.0127 MM) STRESSED KAPTON

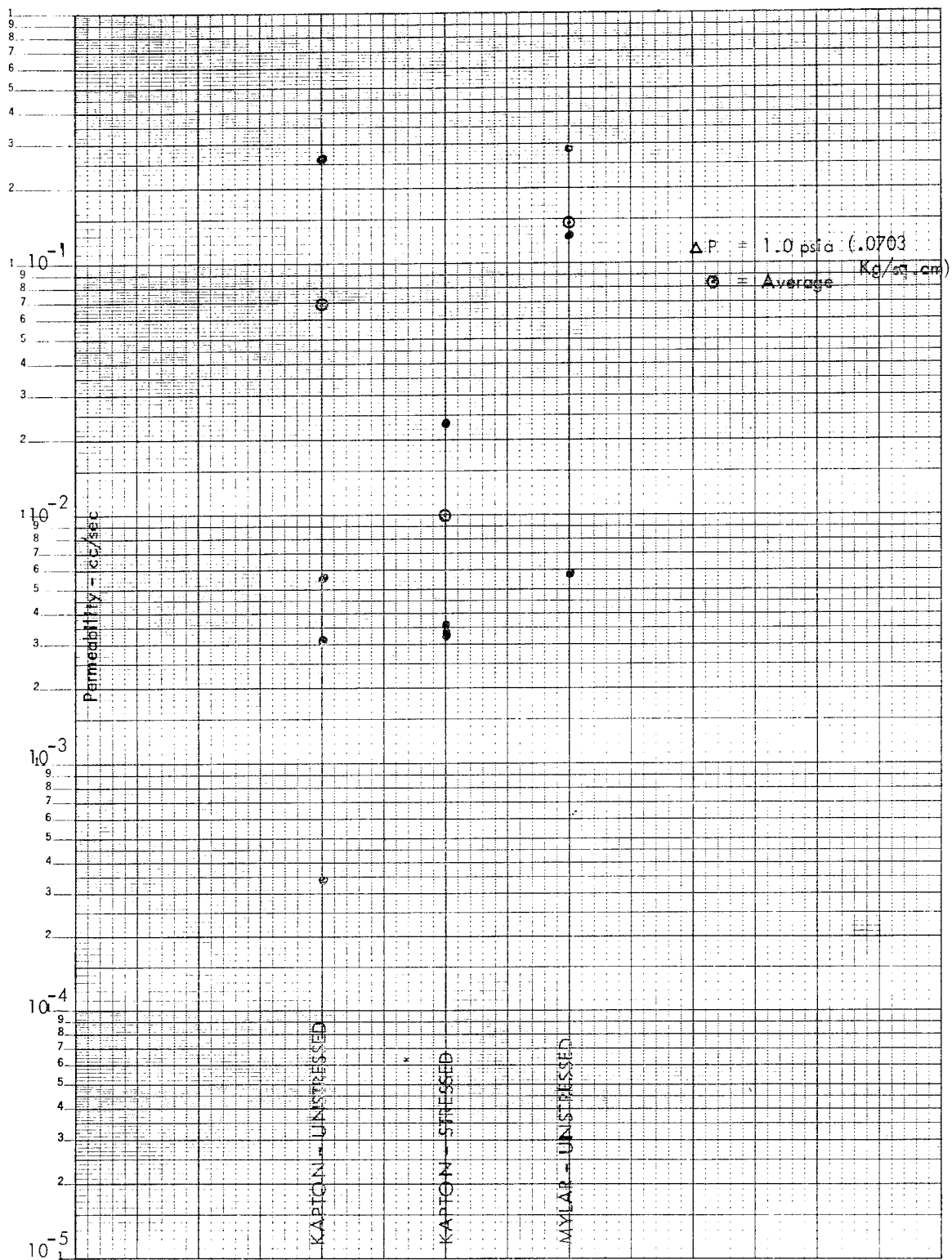

FIGURE 15 - LIQUID HYDROGEN PERMEABILITY - 0.25-MIL (0.00635 MM) FILMS

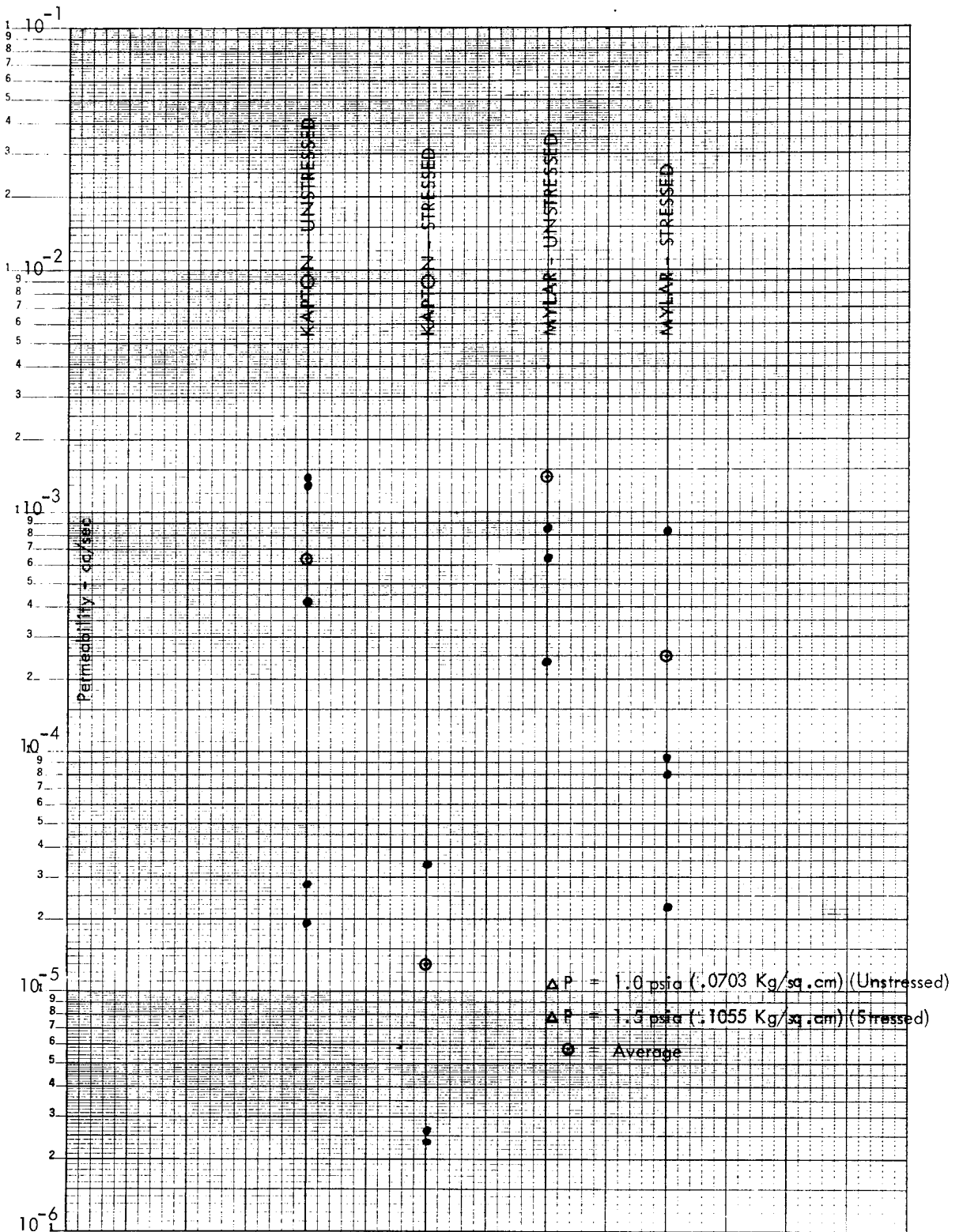

FIGURE 16 - LIQUID HYDROGEN PERMEABILITY - 0.50-MIL (0.0127 MM) FILMS

performed well with a 51.71 mm Hg (1 psi) ΔP . No further tests were performed on the 1/4-mil Mylar.

Under all conditions the Mylar and Kapton films exhibited almost identical permeability trends. The following analyses and conclusions therefore apply to both films unless otherwise noted.

Except for the unstressed 1/4-mil Kapton in which the -195°C (-320°F) permeability was about the same as that at room temperature, the helium permeability increased with a decrease in temperature in all the 1/4-mil films. The same was true of the 1/2-mil films between -195°C and -252°C . However, the 1/2-mil unstressed films showed a decrease in helium permeability with decreasing temperature to -195°C whereas the 1/2-mil stressed film helium permeabilities were about the same at room temperature and -195°C .

Stressing the films to 20% of ultimate strength increases the helium permeability 1 to 3 orders of magnitude while at the same time decreasing the film's permeability to liquid hydrogen at -252°C .

At -252°C both film thickness evaluated are more permeable to LH_2 than to GH_e . However, when stressed the inverse is true with the films being more permeable to the GH_e .

There was less data scatter and lower specific permeability in the 1/2-mil films than in the 1/4-mil films indicating better quality and uniformity. In general, the Kapton film appears to be of better quality regardless of temperature, stress, or thickness. This conclusion was also reflected in the results of the other tests (i.e., Twist-Flex, bond-strength, etc.) conducted in Task 1.

3.1.2 Film Flexibility

The flexibility of each film materials at cryogenic temperatures (-195°C and -252°C) was determined using the "Twist-Flex" method (References 1, 3 and 7).

The Twist-flex test apparatus is described and illustrated in detail in References 3 and 7, but briefly, the twist-flex tester rotates one of two 8.89 cm (3.5 in) diameter horizontal parallel circular plates centered on the same vertical axis. The test specimen is fastened to the plates and the system submerged in the test cryogen (liquid nitrogen or liquid hydrogen). During operation, the plates oscillate horizontally over a 90° angle while undergoing a simultaneous vertical oscillation of 3.33 cm (1.313 inches) causing a twist flexing motion as shown in Figure 17 .

The twist-flex sample is nominally 10.16 cm (4 inches) wide by 27.94 cm (11 inches) long. Around the periphery on each side of the specimens a 1.25 cm (0.5 inch) strip of GT-300 heat sensitive tape was bonded to prevent crack propagations from the cut edges. Prior to testing, each sample was leak tested for defects using the procedures specified in Reference 3. Any sample showing detectable leakage ($> 3 \times 10^{-3}$ cc/sec) was discarded.

The test specimens were each cycled for a predetermined number of cycles then removed and inspected. If a sample appeared intact then the number of cycles for the next sample was increased in an attempt to establish a threshold value . If the sample was visibly damaged then the number of cycles for the subsequent sample was reduced. After the testing was completed, the intact samples were rechecked for helium leakage and this value recorded.

The results of the Twist-Flex tests are shown in Table III. The 1/2-mil Mylar remained relatively intact up to 120 cycles at -195°C and 15 cycles at -252°C. The 1/4-mil Mylar went 200 cycles at -195°C and 20 cycles at -252°C. The Kapton films performed better than Mylar in each of the thicknesses tested. The 1/2-mil Kapton withstood 287 cycles at -195°C and 37 cycles at -252°C. The 1/4-mil Kapton was cycled 875 and 350 cycles at -195°C and -252°C respectively. The Twist-Flex test gave excellent reproducibility and even with only five samples the threshold was bracketed reasonably well. One factor that possibly helped to reduce the scatter was that no sample was Twist-Flex tested that revealed pinhole leakage ($> 10^{-3}$ cc/sec) when checked as indicated above.

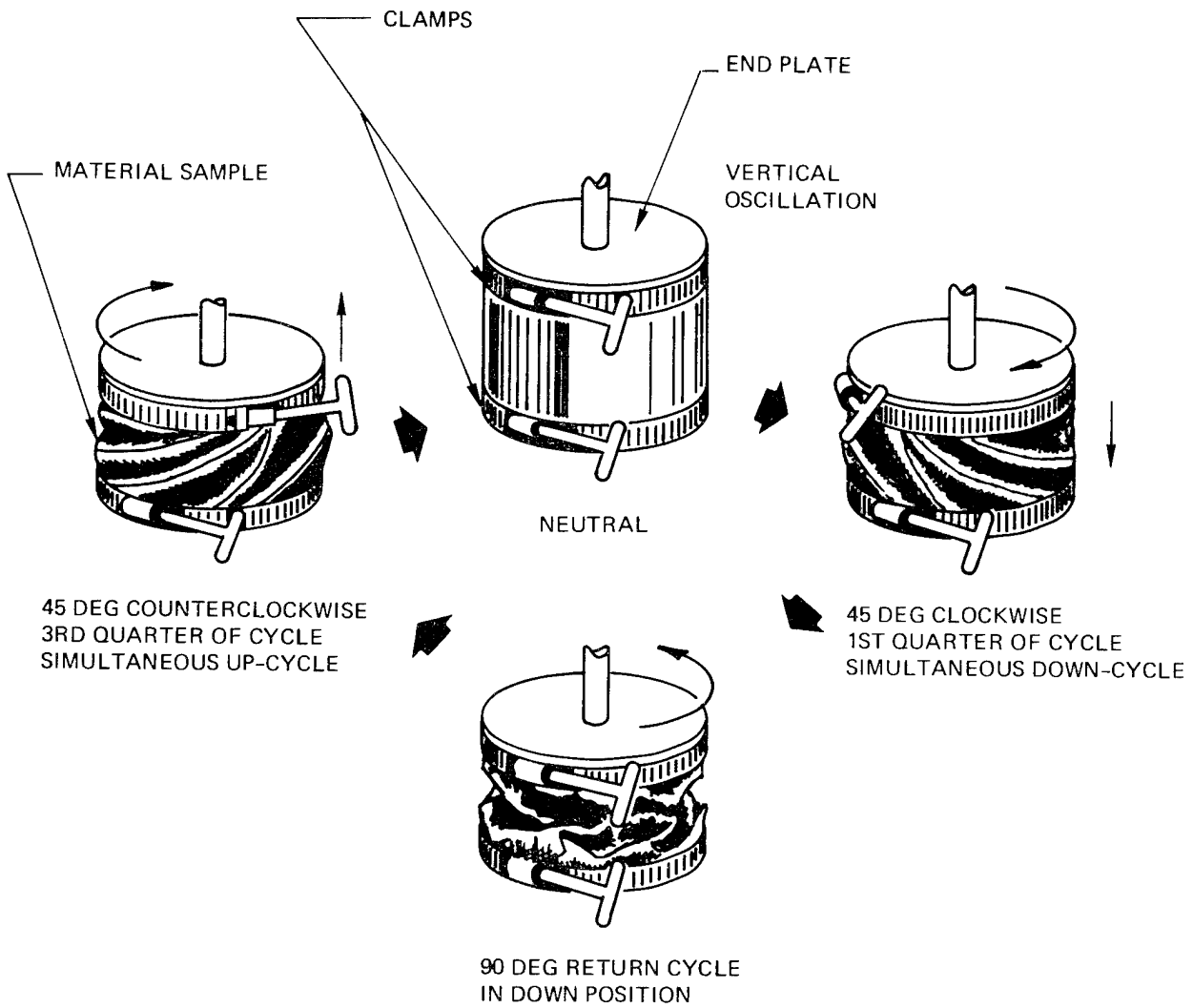

Figure 17 : TWIST-FLEX ACTION

TABLE III TWIST-FLEX TESTING RESULTS

Film	Spec. No.	Film Thickness mils (mm)	Test Temp. °F (°C)	Cycles	Results	Leak Rate After Test cc/sec
Mylar	T1/2M-1	.5 (0.127)	-423 (-252)	100	Torn	-
	-2	"	"	75	Torn	-
	-3	"	"	50	Torn	-
	-4	"	"	25	Torn	-
	-5	"	"	15	Intact	17
	-6	"	"	20	Torn	-
Mylar	T1/2M-7	.5 (.0127)	-320 (-195)	30	Intact	9.5
	-8	"	"	60	Intact	79
	-9	"	"	120	Intact	> 200
	-10	"	"	150	Torn	-
	-11	"	"	135	Torn	-
	Mylar	T1/4M-1	.25 (.00635)	-423 (-252)	15	Intact
-2		"	"	25	Torn	-
-3		"	"	20	Intact	0
-4		"	"	22	Torn	-
-5		"	"	21	Torn	-
-6		"	"	20	Intact	0.003
Mylar	T1/4M-7	.25 (.00635)	-320 (-195)	150	Intact	140
	-8	"	"	200	Intact	13.7
	-9	"	"	250	Torn	-
	-10	"	"	225	Torn	-
	-11	"	"	212	Torn	-
Kapton	T1/2K-1	.5 (.0127)	-423 (-252)	20	Intact	27.7
	-2	"	"	40	Torn	-
	-3	"	"	25	Intact	0
	-4	"	"	30	Intact	0.00033
	-5	"	"	35	Intact	No test
	-6	"	"	37	Intact	0.00133

TABLE III TWIST-FLEX TESTING RESULTS (Continued)

Film	Spec. No.	Film Thickness mils (mm)	Test Temp. °F (°C)	Cycles	Results	Leak Rate After Test cc/sec
Kapton	T1/2K-7	.5 (.0127)	-320 (-195)	300	Torn	-
	-8	↓	↓	250	Intact	0
	-9	↓	↓	300	Torn	-
	-10	↓	↓	275	Intact	0
	-11	↓	↓	287	Intact	0.0005
Kapton	T1/4K-1	.25 (.00635)	-423 (-252)	90	Intact	0.002
	-2	↓	↓	100	Intact	0.0423
	-3	↓	↓	200	Intact	0.066
	-4	↓	↓	300	Intact	0.0023
	-5	↓	↓	423	Torn	-
	-6	↓	↓	350	Intact	21.0
Kapton	T1/4K-7	.25 (.00635)	-320 (-195)	300	Intact	0.0233
	-8	↓	↓	400	Intact	0.155
	-9	↓	↓	500	Intact	0.0883
	-10	↓	↓	700	Intact	0.12
	-11	↓	↓	875	Intact	1.06

3.1.3 Bond Strength Tests

The purpose of these tests were to establish the baseline bond strength of Mylar and Kapton film utilizing either GT-100 or GT-300 adhesives (GT Schjeldahl Co.). GT-100 is an unbacked adhesive film 0.5 mils thick and GT-300 is a Mylar (0.5 mils) backed adhesive film also 0.5 mils thick. Both are heat bondable. Butt and lap joint configurations were studied with each film material and film thickness as shown in Figure 18. A hand held sealing iron set at $165^{\circ}\text{C} \pm 5^{\circ}\text{C}$ ($330^{\circ} \pm 10^{\circ}\text{F}$) was used to make the joints.

The results of the bond strength testing of the lap- and butt-type joints at R.T., -195°C , -252°C are tabulated in Tables IV to XI. The specimens were tested to failure in an Instron test machine using the load rate indicated in the tables.

Terminology used in describing the type of failures occurring in the bond specimens is explained below:

<u>FAILURE TERMINOLOGY</u>		
<u>FAILURE LOCATION</u>	<u>FAILURE TYPE</u>	
Grip	Film Tensile or Tear	Film failures in the specimen grips or within 3.18 mm (0.125") of grips.
Adjacent	Film Tensile or Tear	Film failures within 3.18 mm (0.125") of joint but not within the joint itself.
Film	Film Tensile or Tear	Single film failures 3.18 mm (0.125") from joint to 3.18 mm (0.125") from grip.
Bond	Bond Shear	Failures of the adhesive joint or film tears within the joint.

All joint results were considered satisfactory in that the joints appear as strong as or stronger than the film. The results also compare favorably with the results obtained under NASA Contract NAS3-7944 (Reference 5).

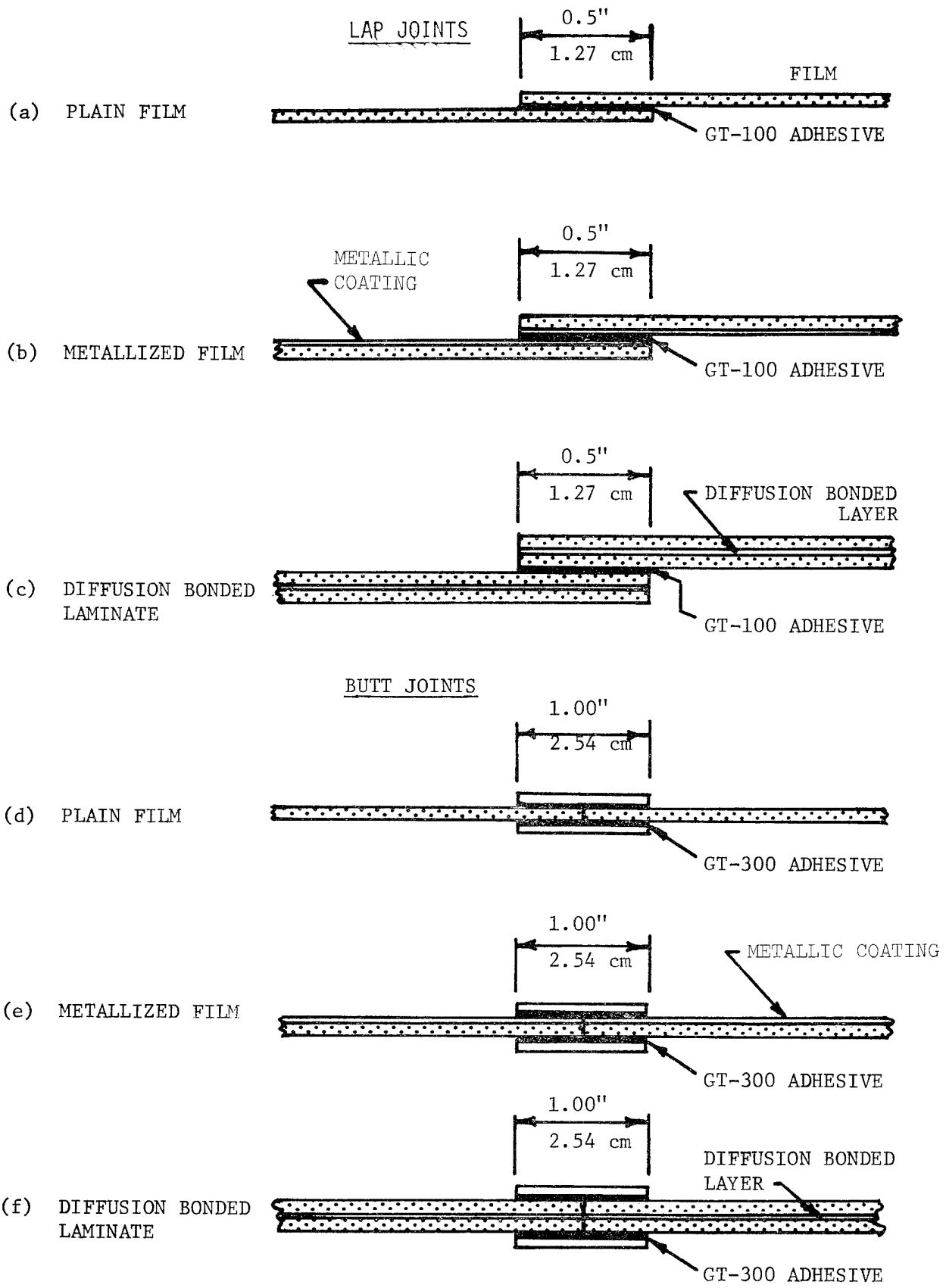







FIGURE 18 JOINT CONCEPTS

TABLE IV BOND STRENGTH TENSILE TESTS - BUTT JOINT
.25 MIL (.00635 mm) KAPTON

Specimen No.	Joint		Test Temp., °F (°C)	Load Lbs (Kg)	Film Stress Ksi (Kg/sq.cm)	Joint Stress Psi (Kg/sq.cm)	Failure Location	Comments
	Lap In. (cm)	Width In. (cm)						
B1/4K-7	.50 (1.27)	1.00(2.54)	RT	4.9 (2.22)	19.6 (1378.0)	4.9 (.34)	Film	  
-8				5.0 (2.27)	20.0 (1406.1)	5.0 (.35)	Film	
-9				5.6 (2.54)	22.4 (1574.9)	5.6 (.39)	Film	
-10				1.2 (0.54)	4.8 (337.5)	1.2 (.08)	Film	
-11				4.7 (2.13)	18.8 (1321.8)	4.7 (.33)	Film	
B1/4K-12			-320 (-195)	7.6 (3.45)	30.4 (2137.3)	7.6 (.53)	Grip	
-13				7.9 (3.58)	31.6 (2221.7)	7.9 (.55)	Adjacent	
-14				6.12 (2.78)	24.4 (1715.5)	6.1 (.43)	Adjacent	
-15				8.8 (3.99)	35.2 (2474.8)	8.8 (.62)	Film	
-16				7.91 (3.58)	31.6 (2221.7)	7.9 (.55)	Film	
B1/4K-1			-423 (-252)	10.5 (4.76)	42.0 (2952.9)	10.5 (.74)	Film	
-2				10.0 (4.54)	40.0 (2812.3)	10.0 (.70)	Adjacent	
-3				7.6 (3.45)	30.4 (2137.3)	7.6 (.53)	Grip	
-4				8.2 (3.71)	32.8 (2306.1)	8.2 (.57)	Grip	
-5				7.9 (3.58)	31.6 (2221.7)	7.9 (.55)	Film	
-6				7.9 (3.58)	31.6 (2221.7)	7.9 (.55)	Grip	

 Each side (overall) lap area = 1 sq. in. (6.45 sq. cm)

 Gage Length = 10.0 in. (25.4 cm); Load Rate = 0.5"/min (1.27 cm/min).









 Gage Length = 5.5 in (13.97 cm); Load Rate = 0.05"/min (.127 cm/min).

TABLE V BOND STRENGTH TENSILE TESTS - BUTT JOINT
.50 MIL (.0127 mm) KAPTON

Specimen No.	Joint		Test Temp., °F (°C)	Load Lbs (Kg)	Film Stress Ksi (Kg/sq.cm)	Joint Stress Psi (Kg/sq.cm)	Failure Location	Comments
	Lap in. (cm)	Width In. (cm)						
B1/2K-7	.5 (1.27)	1.00(2.54)	RT	9.7 (4.39)	19.4 (1363.9)	9.7 (.68)	Film	 
-8				8.3 (3.76)	16.6 (1167.1)	8.3 (.58)	Film	
-9				11.4 (5.17)	22.8 (1602.9)	11.4 (.80)	Film	
-10				10.6 (4.81)	21.2 (1490.5)	10.6 (.75)	Film	
-11				10.1 (4.58)	20.2 (1420.2)	10.1 (.70)	Film	
B1/2K-12			-320 (-195)	20.0 (9.07)	40.0 (2812.3)	20.0 (1.41)	Film	 
-13				14.6 (6.62)	29.2 (2053.0)	14.6 (1.03)	Adjacent	
-14				12.4 (5.62)	24.8 (1743.6)	12.4 (.87)	Grip	
-15				16.7 (7.57)	33.4 (2348.3)	16.7 (1.17)	Grip	
-16				20.0 (9.07)	40.0 (2812.3)	20.0 (1.41)	Bond	
B1/2K-1			-423 (-252)	22.7 (10.29)	45.4 (3192.0)	22.7 (1.59)	Bond	 
-2				19.9 (9.02)	39.8 (2798.2)	19.9 (1.40)	Adjacent	
-3				21.4 (9.70)	42.8 (3009.1)	21.4 (1.50)	Film	
-4				19.3 (8.75)	38.6 (2714.0)	19.3 (1.36)	Grip	
-5				21.1 (9.57)	42.2 (2967.0)	21.1 (1.48)	Film	
-6				8.6 (3.90)	17.2 (1209.3)	8.6 (.60)	Film	

 Each side (overall) lap area = 1 sq. in. (6.45 sq. cm)

 Gage Length = 10.0" (25.4 cm); Load Rate = 0.5"/min (1.27 cm/min)

 Gage Length = 5.5" (13.97 cm); Load Rate = 0.05"/min (0.127 cm/min).

TABLE VI BOND STRENGTH TENSILE TESTS - BUTT JOINT
 .25 MIL (.00635 mm) MYLAR



Specimen No.	Joint		Test Temp., °F (°C)	Load Lbs (Kg)	Film Stress Ksi (Kg/sq.cm)	Joint Stress Psi (Kg/sq.cm)	Failure Location	Comments
	Lap In. (cm)	Width In. (cm)						
B1/4M-7	.5 (1.27)	1.00(2.54)	RT	4.0 (1.81)	16.0 (1124.9)	4.0 (.28)	Film	
-8				3.8 (1.72)	15.2 (1068.6)	3.8 (.27)	Film	
-9				4.6 (2.09)	18.4 (1293.6)	4.6 (.32)	Film	
-10				3.8 (1.72)	16.2 (1138.9)	3.8 (.27)	Adjacent	
-11				4.3 (1.95)	17.2 (1209.3)	4.3 (.30)	Film	
B1/4M-12			-320 (-195)	6.1 (2.77)	2.4 (1715.5)	6.1 (.43)	Grip	
-13				7.2 (3.27)	28.8 (2024.8)	7.2 (.51)	Grip	
-14				8.8 (3.63)	35.2 (2474.8)	8.8 (.62)	Grip	
-15				7.6 (3.45)	30.4 (2137.3)	7.6 (.53)	Grip	
-16				8.6 (3.90)	34.4 (2418.6)	8.6 (.60)	Grip	
B1/4M-1			-423 (-252)	6.9 (3.13)	27.6 (1940.5)	6.9 (.48)	Grip	
-2				11.4 (5.17)	45.6 (3206.0)	11.4 (.80)	Grip	
-3				10.4 (4.72)	41.6 (2924.8)	10.4 (.73)	Film	
-4				9.4 (4.26)	37.6 (2643.5)	9.4 (.66)	Grip	
-5				1.8 (.82)	7.2 (506.2)	1.8 (.13)	Grip	

Each side (overall) lap area = 1 sq. in (6.45 sq. cm)

Gage Length = 10.0" (25.4 cm); Load Rate = 2.0"/min (5.08 cm/min).

Gage Length = 5.5" (13.97 cm); Load Rate = 0.05"/min (0.127 cm/min).

TABLE VII BOND STRENGTH TENSILE TESTS - BUTT JOINT
.50 MIL (.0127 mm) MYLAR

Specimen No.	Joint		Test Temp., °F (°C)	Load Lbs (Kg)	Film Stress Ksi (Kg/sq.cm)	Joint Stress Psi (Kg/sq.cm)	Failure Location	Comments
	Lap In. (cm)	Width In. (cm)						
B1/2M-7	.5 (1.27)	1.00(2.54)	RT	12.7 (5.76)	25.4 (1785.8)	12.7 (.89)	Film	  
-8				14.7 (6.67)	29.4 (2067.0)	14.7 (1.03)	Adjacent	
-9				15.5 (7.03)	31.0 (2179.5)	15.5 (1.09)	Adjacent	
-10				14.2 (6.44)	28.4 (1996.7)	14.2 (1.00)	Adjacent	
-11				11.9 (5.40)	23.8 (1673.3)	11.9 (.83)	Film	
B1/2M-12			-320 (-195)	18.5 (8.16)	37.0 (2601.4)	18.5 (1.30)	Adjacent	
-13				19.2 (8.71)	38.4 (2699.8)	19.2 (1.35)	Grip	
-14				17.3 (7.84)	34.6 (2432.6)	17.3 (1.22)	Grip	
-15				22.8 (10.34)	45.6 (3206.0)	22.8 (1.60)	Adjacent	
-16				25.0 (11.34)	50.0 (3515.4)	25.0 (1.76)	Adjacent	
B1/2M-1			-423 (-252)	18.5 (8.16)	39.0 (2742.0)	18.5 (1.30)	Grip	
-2				17.7 (8.03)	35.4 (2488.9)	17.7 (1.24)	Grip	
-3				17.7 (8.03)	35.4 (2488.9)	17.7 (1.24)	Grip	
-4				23.0 (10.43)	46.0 (3234.0)	23.0 (1.62)	Grip	
-5				9.2 (4.17)	18.4 (1265.5)	9.2 (.65)	Grip	
-6				24.4 (11.07)	48.8 (3431.0)	24.4 (1.72)	Adjacent	

 Each side (overall) lap area = 1 sq. in. (6.45 sq. cm).

 Gage Length = 10.0" (25.4 cm); Load Rate = 2.0"/min (5.08 cm/min).

 Gage Length = 5.5" (13.97 cm); Load Rate = 0.05"/min (0.127 cm/min).

TABLE VIII BOND STRENGTH TENSILE TESTS - LAP JOINT
 .25 MIL (.00635 mm) KAPTON

Specimen No.	Joint		Test Temp., °F (°C)	Load Lbs (Kg)	Film Stress Ksi (Kg/sq.cm)	Joint Stress Psi (Kg/sq.cm)	Failure Location	Comments
	Lap In. (cm)	Width In. (cm)						
L1/4K-7	.5 (1.27)	1.00(2.54)	RT	4.5 (.93)	18.0 (1265.5)	9.0 (.63)	Film	
-8				6.0 (2.72)	24.0 (1687.4)	12.0 (.84)	Film	
-9				6.5 (2.95)	26.0 (1828.0)	13.0 (.91)	Film	
-10				7.9 (3.58)	31.6 (2221.7)	15.8 (1.11)	Film	
-11				6.6 (2.99)	26.4 (1856.1)	13.2 (.93)	Film	
L1/4K-13			-320 (-195)	9.2 (4.17)	36.8 (2587.3)	18.4 (1.29)	Film	
-14				10.5 (4.76)	42.0 (2952.9)	21.0 (1.47)	Bond	
-15				10.2 (4.63)	40.8 (2868.5)	20.4 (1.41)	Adjacent	
-16				5.4 (2.45)	21.6 (1518.6)	10.8 (.76)	Film	
-17				9.7 (4.40)	38.8 (2727.9)	19.4 (1.36)	Adjacent	
L1/4K-1			-423 (-252)	8.8 (3.99)	35.6 (2502.9)	17.6 (1.24)	Grip	
-2				8.3 (3.76)	33.2 (2334.2)	16.6 (1.17)	Grip	
-3				4.0 (1.81)	16.0 (1124.9)	8.0 (.56)	Grip	
-4				10.9 (4.94)	43.6 (3065.3)	21.8 (1.53)	Grip	
-5				9.0 (4.08)	36.0 (2531.0)	18.0 (1.26)	Film	

Each side (overall) lap area = 1 sq. in. (6.45 sq. cm)

Gage Length = 10.0" (25.4 cm); Load Rate = 0.5"/min (1.27 cm/min).

Gage Length = 5.5" (13.97 cm); Load Rate = 0.05"/min (0.127 cm/min).

TABLE IX BOND STRENGTH TENSILE TESTS - LAP JOINT
 .50 MIL (.0127 mm) KAPTON

Specimen No.	Joint		Test Temp., °F (°C)	Load Lbs (Kg)	Film Stress Ksi (Kg/sq.cm)	Joint Stress Psi (Kg/sq.cm)	Failure Location	Comments
	Lap In. (cm)	Width In. (cm)						
L1/2K-18	.5 (1.27)	1.00 (2.54)	RT	11.5 (5.22)	23.0 (1617.1)	23.0 (1.62)	Adjacent Film	
-19			↓	12.7 (5.76)	25.4 (1785.8)	25.4 (1.79)	Film	
-20			↓	8.7 (3.95)	17.4 (1223.3)	17.4 (1.22)	Adjacent	
-21			↓	10.3 (4.67)	20.6 (1448.3)	20.6 (1.45)	Grip	
-22			↓	10.9 (4.94)	21.8 (1532.7)	21.8 (1.53)		
L1/2K-12			-320 (-195)	17.4 (7.89)	34.8 (2446.7)	34.8 (2.45)	Adjacent Bond	
-13			↓	16.6 (7.53)	33.2 (2348.3)	33.2 (2.35)	Bond	
-14			↓	16.7 (7.58)	33.4 (2348.2)	33.4 (2.35)	Film	
-15			↓	16.9 (7.67)	33.8 (2376.4)	33.8 (2.38)	Film	
-16			↓	16.1 (7.30)	32.2 (2263.9)	32.2 (2.27)	Grip	
L1/2K-1			-423 (-252)	16.1 (7.30)	32.2 (2263.9)	32.2 (2.27)	Bond	
-2			↓	15.4 (6.98)	30.8 (2165.5)	30.8 (2.17)	Bond	
-3			↓	16.6 (7.53)	33.2 (2348.3)	33.2 (2.35)	Bond	
-4			↓	12.8 (5.81)	25.6 (1799.9)	25.6 (1.80)	Film	
-5			↓	15.1 (6.85)	30.2 (2123.3)	30.2 (2.12)	Adjacent	

Each side (overall) lap area = 1 sq. in. (6.45 sq. cm)

Gage Length = 10.0" (25.4 cm); Load Rate = 0.5"/min (1.27 cm/min).

Gage Length = 5.5" (13.97 cm); Load Rate = 0.05"/min (0.127 cm/min).

TABLE X BOND STRENGTH TENSILE TESTS - LAP JOINT
 .25 MIL (.00635 mm) MYLAR



Specimen No.	Joint		Test Temp. °F (°C)	Load Lbs (Kg)	Film Stress Ksi (Kg/sq.cm)	Joint Stress Psi (Kg/sq.cm)	Failure Location	Comments
	Lap In. (cm)	Width In. (cm)						
L1/4M -7	.5 (1.27)	1.00(2.54)	RT	5.4 (2.45)	21.6 (1518.6)	10.8 (.76)	Grip	
-8				4.9 (2.22)	19.6 (1378.0)	9.8 (.69)	Film	
-9				5.6 (2.54)	22.4 (1576.9)	11.2 (.78)	Grip	
-10				4.4 (2.00)	17.6 (1237.4)	8.8 (.62)	Film	
-11				3.9 (1.77)	15.6 (1096.8)	7.8 (.55)	Film	
L1/4M -12			-320 (-195)	8.8 (3.99)	35.2 (2474.8)	17.6 (1.24)	Grip	
-13				8.5 (3.86)	34.0 (2390.4)	17.0 (1.20)	Grip	
-14				8.8 (3.99)	35.2 (2474.8)	17.6 (1.24)	Grip	
-15				5.2 (2.36)	20.8 (1462.4)	10.4 (.73)	Adjacent	
-16				8.5 (3.86)	34.0 (2390.4)	17.0 (1.20)	Film	
L1/4M -1			-423 (-252)	11.6 (5.26)	46.4 (3262.2)	23.2 (1.63)	Film	
-2				3.7 (1.68)	14.8 (1040.5)	7.4 (.52)	Film	
-3				10.7 (4.85)	42.8 (3009.2)	21.4 (1.50)	Grip	
-4				5.2 (2.36)	20.8 (1462.4)	10.4 (.73)	Film	
-5				9.2 (4.17)	36.8 (2587.3)	18.4 (1.29)	Film	

Each side (overall) lap area = 1 sq. in. (6.45 sq. cm).

Gage Length = 10.0" (25.4 cm); Load Rate = 2.0"/min (5.08 cm/min).

Gage Length = 5.5" (13.97 cm); Load Rate = .05"/min (.127 cm/min).

TABLE XI BOND STRENGTH TENSILE TESTS - LAP JOINT
 .5 MIL (.0127 mm) MYLAR

Specimen No.	Joint		Test Temp. °F (°C)	Load Lbs (Kg)	Film Stress Ksi (Kg/sq.cm)	Joint Stress Psi (Kg/sq.cm)	Failure Location	Comments
	Lap In. (cm)	Width In. (cm)						
L1/2M -7	.5 (1.27)	1.00(2.54)	RT	10.6 (1.81)	21.2 (1490.5)	21.2 (1.49)	Film	
-8			→	12.3 (5.44)	24.6 (1729.6)	24.6 (1.73)	Film	
-9				16.0 (7.26)	32.0 (2249.8)	32.0 (2.25)	Film	
-10				16.6 (7.53)	33.2 (2334.2)	33.2 (2.33)	Film	
-11			→	15.8 (7.17)	31.6 (2221.7)	31.6 (2.22)	Adjacent	
L1/2M -12			-320 (-195)	22.6 (10.25)	45.2 (3177.9)	45.2 (3.12)	Adjacent	
-13			→	14.8 (6.71)	29.6 (2081.1)	29.6 (2.08)	Grip	
-14				23.9 (10.18)	47.8 (3360.7)	47.8 (3.36)	Adjacent	
-15			→	18.7 (8.48)	34.4 (2629.5)	37.4 (2.63)	Grip	
-16				24.4 (11.07)	48.8 (3431.0)	48.8 (3.43)	Adjacent	
L1/2M -1			-423 (-252)	12.7 (5.76)	25.4 (1785.7)	25.4 (1.78)	Film	
-2			→	24.5 (11.11)	49.0 (3445.0)	49.0 (3.44)	Film	
-3				24.4 (11.07)	48.8 (3431.0)	48.8 (3.43)	Film	
-4			→	20.1 (9.12)	40.2 (2836.3)	40.2 (2.83)	Film	
-5				23.7 (10.75)	47.4 (3332.6)	47.4 (3.33)	Adjacent	

 Each side (overall) lap area = 1 sq. in. (6.45 sq. cm).

 Gage Length = 10.0" (25.4 cm); Load Rate = 2.0"/min (5.08 cm/min).

 Gage Length = 5.5" (13.97 cm); Load Rate = 0.05"/min (0.127 cm/min).

3.1.4 Interply Inflation Tests

The purpose of the interply inflation tests was to assess the quantity of gas and/or cryogen diffusing through the polymeric films at cryogenic temperatures. Tests under NASA Contract NAS3-6288 (Reference 3) indicated that in times as short as 5 minutes sufficient gas permeation occurred through the polymeric films at low temperatures to cause interply inflation of bladders during warm-up.

The test samples consisted of two plies of Mylar or Kapton, 10.16 cm x 27.9 cm (4" x 11") in size, bonded together around the edges with GT-100 and -300 adhesive as shown in Figure 19 to form an enclosed envelope. Each ply of film was inspected for leakage prior to assembling the specimen to insure integrity of the film. Films showing detectable leakage ($> 10^4$ cc/sec) were discarded. The thickness of the sample was then measured (in case air was trapped in the specimen during sealing) at room temperature. To measure that thickness the entrapped gas was forced to one end of the specimen and an average thickness reading obtained. However, as the data in Tables XII and XIII shows none of the samples contained initially entrapped air. Next the sample was submerged in either liquid nitrogen or liquid hydrogen, depending on the test temperature desired, for 5 minutes. After the time period was over, the sample was immediately withdrawn from the cryogen and permitted to warm up to room temperature. If any fluid (gas or liquid) permeated the film, the sample would expand as the temperature increased. As the data in Tables XII and XIII shows, no evidence of interply inflation was noted.

Since the results of the -195°C and -252°C interply inflation tests were contrary to results previously published for the Mylar and Kapton film (References 3 and 7), several additional tests were conducted to insure that the results were valid.

First the submersion time on selected samples was increased to 30 minutes in both liquid nitrogen and liquid hydrogen and again no inflation occurred. One Mylar and one Kapton specimen was then submerged for 24 hours in liquid nitrogen with no evidence of inflation. Finally, specimens of 1/4 mil Mylar

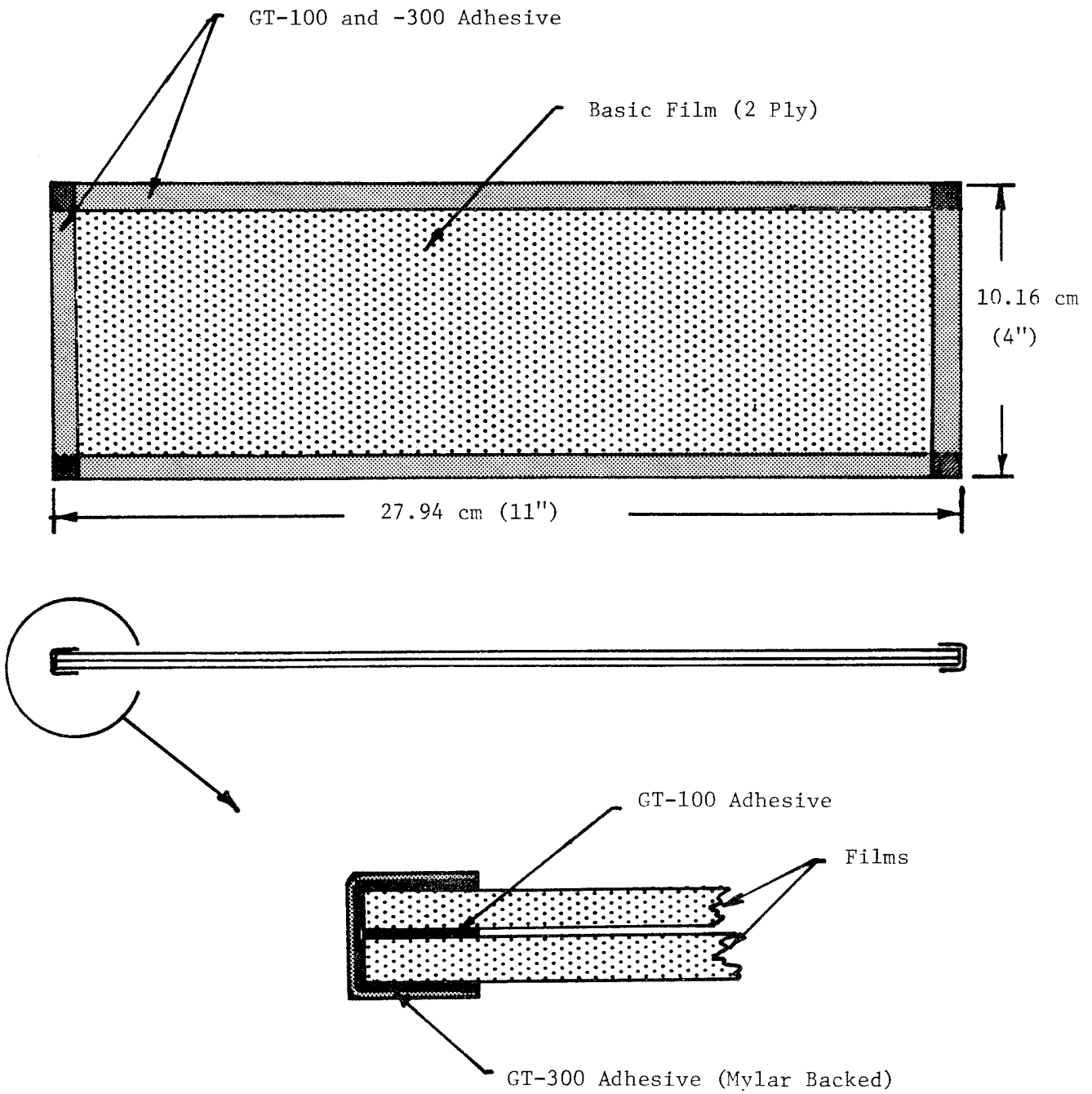

FIGURE 19 INTERPLY INFLATION SPECIMEN

TABLE XII INTERPLY INFLATION TESTS AT -320°F (-195°C)

Specimen No.	Material	Film Thickness mils (mm)	Coating	Initial Thickness	Exposure Time		
					5 Min.	30 Min.	24 Hrs.
					Inflation Thickness	Inflation Thickness	Inflation Thickness
1	Mylar	.25 (.00635)	None	0	NC	NC	NC
2					NC	NC	NC
3	Mylar	.25 (.00635)	None	0	-	-	-
4					-	-	-
5	Kapton	.50 (.0127)	None	0	NC	NC	NC
6					NC	NC	NC
7	Mylar	.50 (.0127)	None	0	-	-	-
8					-	-	-
9	Kapton	.25 (.00635)	None	0	NC	NC	NC
10					NC	NC	NC
11	Mylar	.25 (.00635)	None	0	NC	NC	NC
12					NC	NC	NC
13	Kapton	.25 (.00635)	None	0	-	-	-
14					-	-	-
15	Kapton	.50 (.0127)	None	0	NC	NC	NC
16					NC	NC	NC
17	Kapton	.50 (.0127)	None	0	-	-	-
18					-	-	-
19	Kapton	.50 (.0127)	None	0	NC	NC	NC
20					NC	NC	NC

NC = No Change

TABLE XIII INTERPLY INFLATION TESTS AT -423°F (-252°C)

Specimen No.	Material	Film Thickness mils (mm)	Coating	Thickness	Exposure Time																	
					5 Min.	30 Min.																
					Inflation Thickness	Inflation Thickness																
21	Mylar	.25 (.00635)	None	0	NC	NC																
22																						
23		.25 (.00635)					None	0	NC	NC												
24																						
25		.50 (.0127)									None	0	NC	NC								
26																						
27		.50 (.0127)													None	0	NC	NC				
28																						
29		.50 (.0127)																	None	0	NC	NC
30																						
31	Kapton	.25 (.00635)	None	0	NC	NC																
32																						
33		.25 (.00635)					None	0	NC	NC												
34																						
35		.50 (.0127)									None	0	NC	NC								
36																						
37		.50 (.0127)													None	0	NC	NC				
38																						
39		.50 (.0127)																	None	0	NC	NC
40																						

NC = No Change

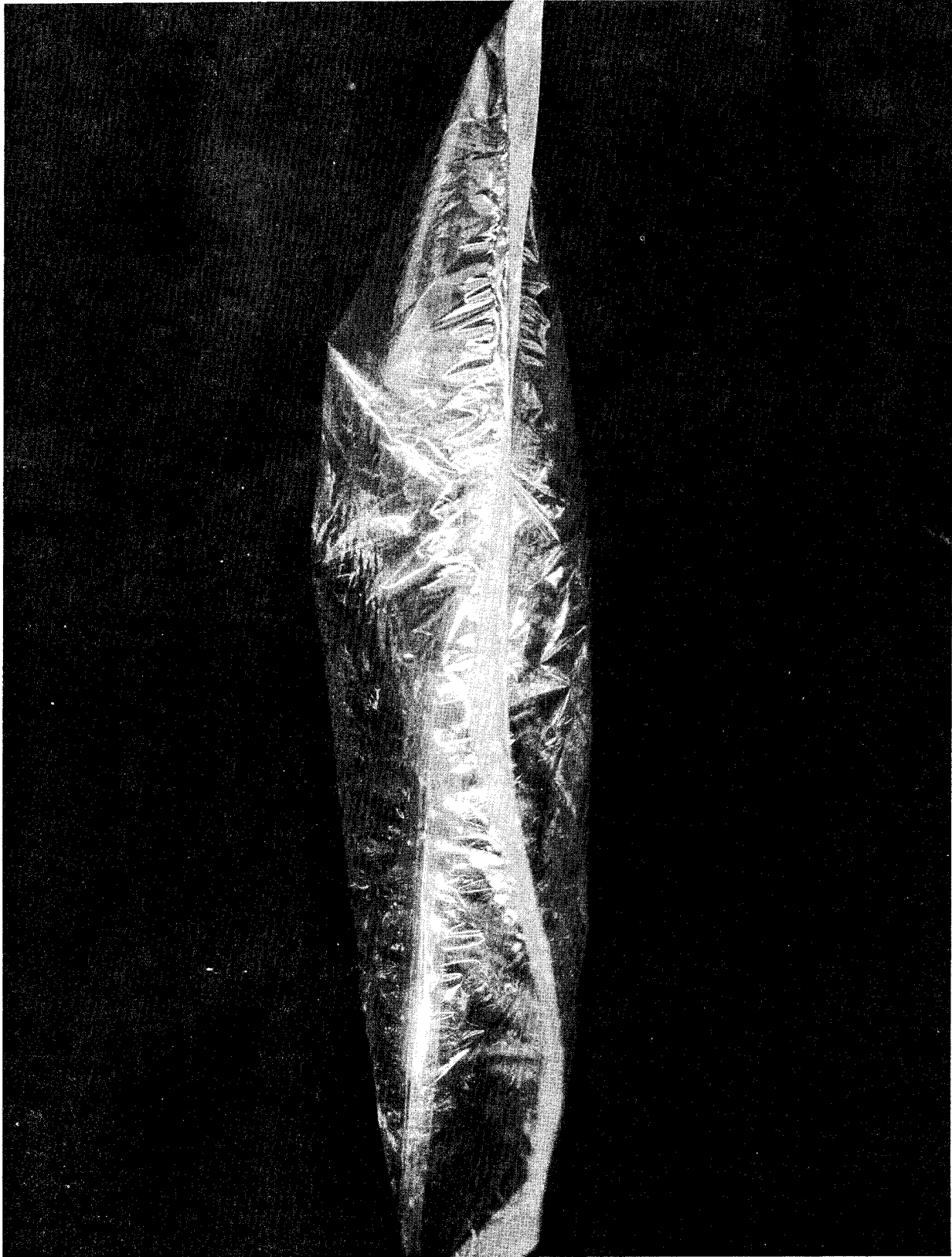

FIGURE 20 INTERPLY INFLATION SPECIMEN IN INFLATED CONDITION

and 1/4 mil Kapton were intentionally punctured with one very small pinhole and then submerged in liquid nitrogen for a period of 5 minutes. When the specimens were removed they immediately inflated to approximately 5.1 cm (2 inches) in depth, indicating inflation will occur rapidly if fluid is allowed to penetrate the film. The inflated specimen is shown in Figure 20.

From these tests it was concluded that careful screening of the film samples can minimize and possibly eliminate interply inflation. However, the slightest imperfection (pinhole, poor seam, thin spot, etc.) will permit inflation to occur. However, on a bladder of any substantial size it may be very difficult to eliminate all of these defects. It should be noted that several areas of the as-received films (both Mylar and Kapton in both thickness) had to be rejected due to pinholes and imperfections. If samples had been taken from these areas then interply inflation would have occurred in these tests.

3.2 Preliminary Coating Evaluation

The objective of this phase of the program was to select ten basic coating concepts and determine their effectiveness in reducing the permeability of either Mylar, Kapton or both. This work on preliminary coating evaluated constituted Task II of the program.

3.2.1 Coating Concepts

The coating concepts studied in this phase of the program are shown in Table XIV. Six of the concepts involved a laminate construction in which two layers of metallized Kapton film were diffusion bonded together. The remaining four concepts were metallized films (one side only).

The selection of a coating concept was based on achieving the maximum reduction in the permeability with the minimum effect on the ability of Mylar and Kapton films to perform satisfactorily in cryogenic bladder applications. The coating properties that had to be considered were: ductility, corrosion resistance, adhesion, fabricability and thickness.

It was desired that the coating be ductile and not work harden in order to provide maximum flex life. Corrosion resistance was desirable to preserve coating continuity during bladder fabrication and storage. The following metals potentially met these requirements; aluminum, copper, gold, and silver.

Good adhesion was necessary in order to maintain coating integrity, but adhesion is related to the application method as well as the coating metal and substrate.

The laminate concept (sandwich construction) indicated in Table XIV is illustrated in Fig. 21. With this concept, the Kapton film is metallized on one side by either sputtering or vacuum-deposition (other processes could be used), taking care to keep all surfaces clean. Two sheets of the metallized film are then stacked with the two metallized surfaces in contact with one another. Heat and pressure [300°C (575°F) and 84.4 Kg/cm^2 (1200 psi) for 5 minutes] are then

TABLE XIV PROPOSED COATINGS

Film Thickness, mils	1/4		1/2	
Coating Thickness, Å	5,000	10,000	5,000	10,000
KAPTON (for sandwich construction)				
Vacuum Deposited Gold		X		X
Sputtered Gold	X	X	X	X
KAPTON (metallized one side)				
Sputtered Aluminum	X			X
MYLAR (metallized one side)				
Sputtered Aluminum	X			X

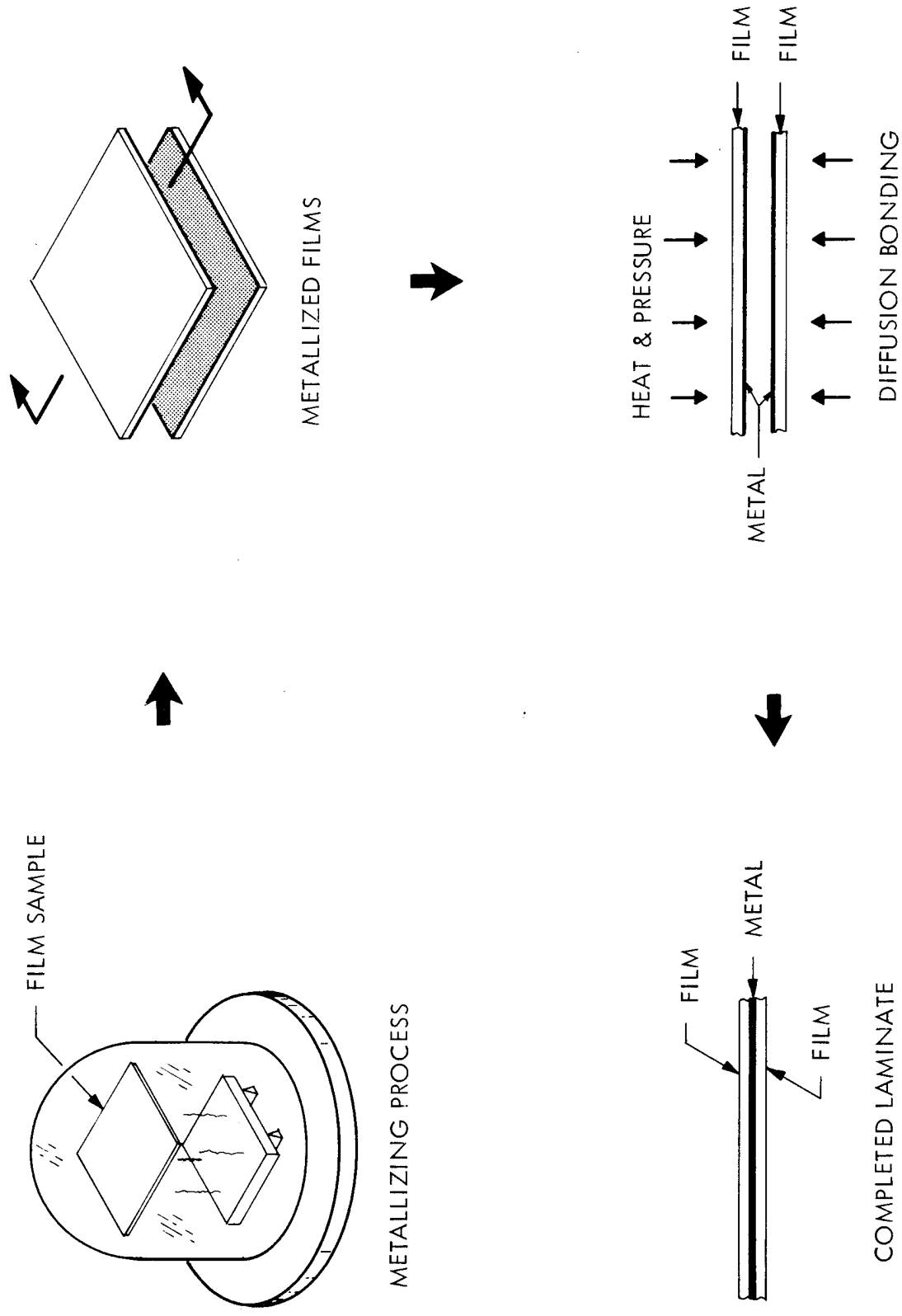

FIGURE 21 DIFFUSION BONDED LAMINATE PROCESS

applied to diffusion bond the two surfaces together. If the metallized surface is of high quality (low porosity), then the two surfaces tend to seal the pores in the other, thereby reducing the overall permeability of the film substantially. The principle is illustrated in Figure 22 with two plies of poorly metallized Kapton film. The individual metallized films have visible pores in the coating which are no longer visible in the diffusion bonded portion. Figure 23 shows the diffusion bonded interface of two layers of gold metallized Kapton.

Of the potentially useful metals for coating, gold best fulfilled the requirements of the sandwich concept. Gold is readily diffusion bonded at temperatures (and pressures) that can be withstood by the Kapton film. It is probable that processes could be developed for using aluminum, copper, or silver; however, techniques for preventing oxidation of the coatings prior to diffusion bonding would complicate processing. Therefore gold was used to evaluate this concept.

Application methods considered for applying the gold coating included sputtering, vacuum deposition, electroless plating, chemical vapor deposition, and ion beam. Sputtering and vacuum deposition were selected for this program. Sputtering has been shown to be capable of applying gold in a dense, uniform, adherent coating of controlled thickness. The method is generally sufficiently energetic to effect good adhesion between the relatively inert gold and Kapton, but for reliability a flash (500 Å) coating of chromium was initially applied to the Kapton, increasing the adherence of the metallization.

During sputtering, atoms of the coating material bombard the substrate at an extremely high velocity. Sputtered atoms have a very high energy (1-10 electron volts) as compared with other deposition techniques (typically 0.1 electron volt) so that a strong bond is made with the substrate and a dense, uniform, nonporous coating is formed. A sputtered coating is shown in Figure 24.

Vacuum deposition is a well established process resulting in uniform coatings. However, it is desirable to prepare the Kapton surface by an initial minimum deposition of an active metal, such as chromium, prior to depositing gold with the vacuum process in order to effect good adhesion. Since vacuum deposition

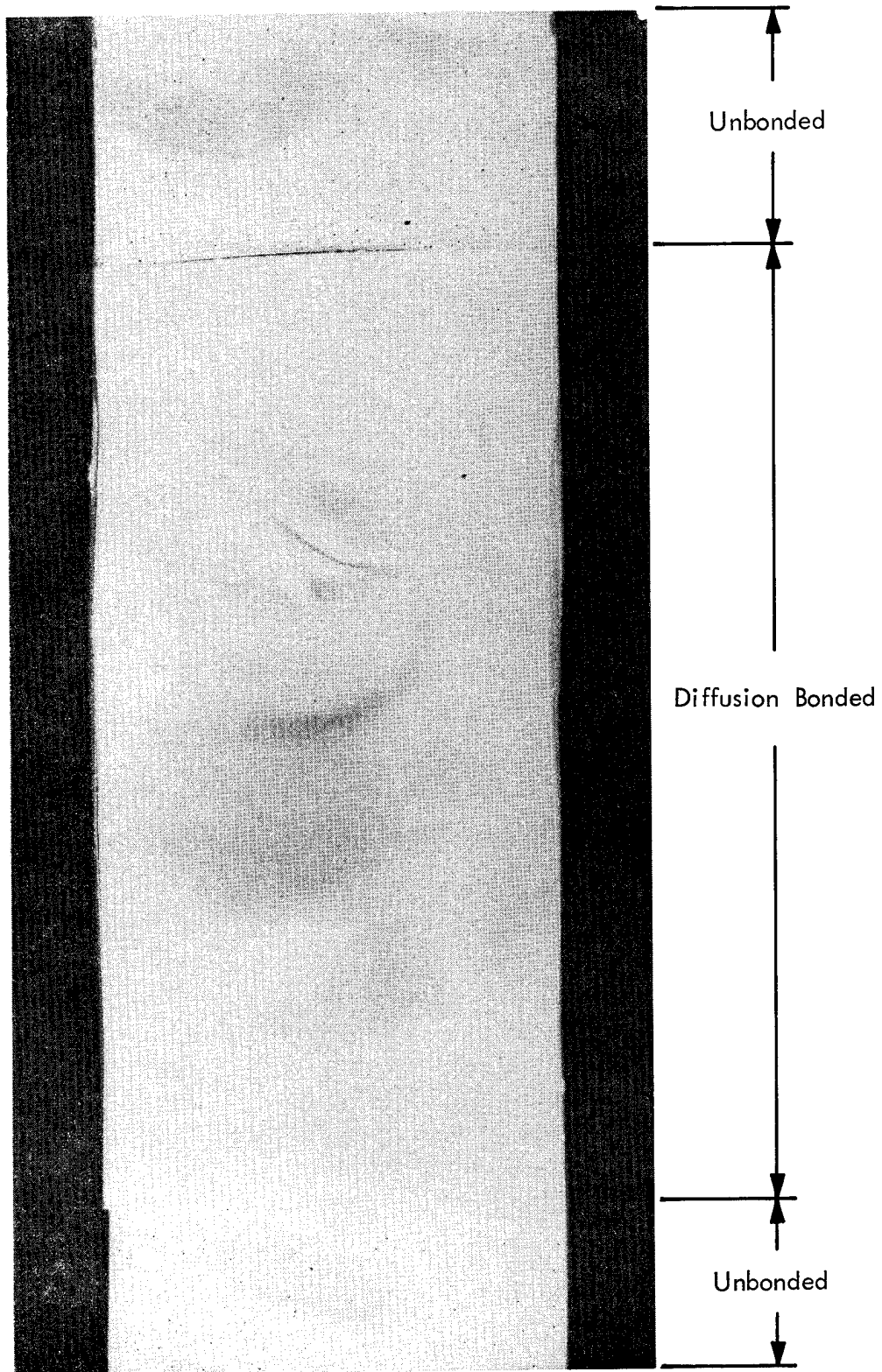

FIGURE 22 VACUUM DEPOSITED GOLD ON KAPTON FILM —
AFTER DIFFUSION BONDING

KAPTON/GOLD LAMINATE

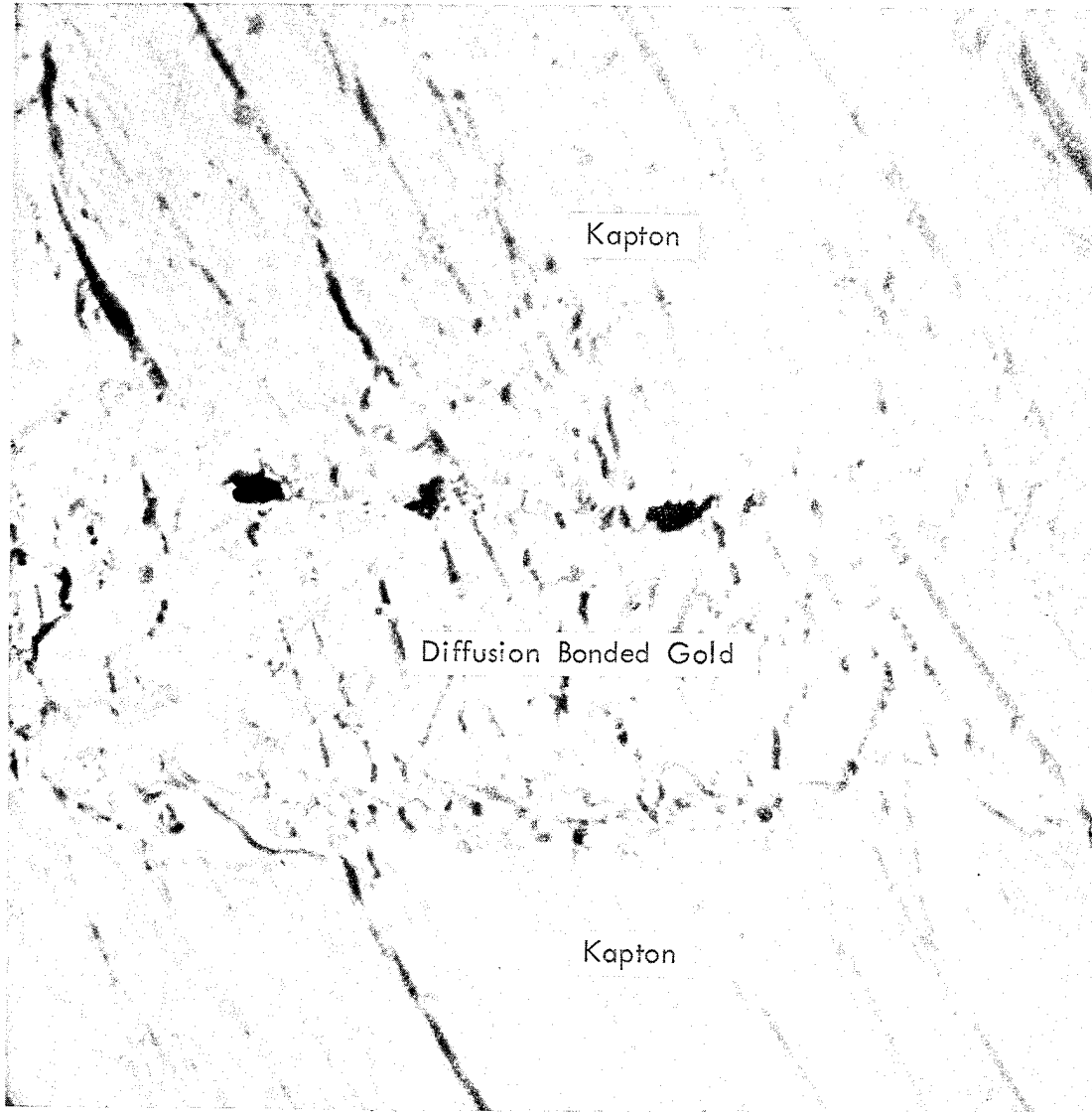

FIGURE 23 DIFFUSION BONDED GOLD-KAPTON FILM

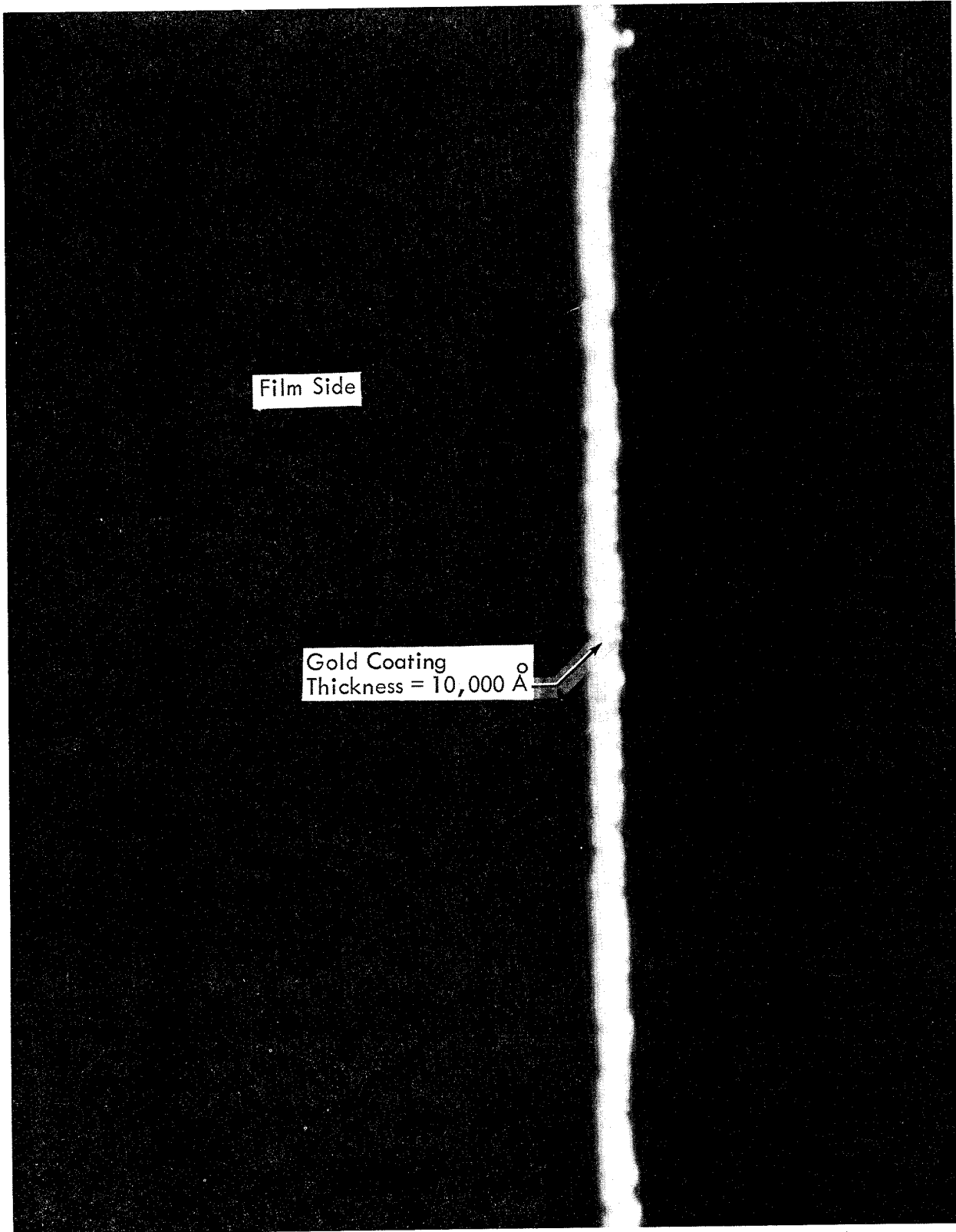

FIGURE 24 SPUTTERED GOLD COATING ON 1/4 MIL KAPTON FILM —
CROSS-SECTION VIEW (5000 X)

is a reliable coating process and widely used, it was desirable to compare it with a sputtered coating with the diffusion bonding concept as shown in Table XIV.

The "sandwich" concept is not applicable to Mylar because of the relatively high temperature required for diffusion bonding, and therefore the single ply concept as indicated in Table XIV was evaluated. Sputtering provides a very thin but dense coating that is not obtainable by the other plating techniques. Aluminum was selected since it is an active metal that adheres relatively well to both Kapton and Mylar. Sputtering of aluminum on Mylar is an established process. For comparison, aluminum was also sputtered on Kapton. Both coatings had a flash of chromium (500 \AA) applied to increase adherence. It appeared desirable to evaluate the performance of a single coating of aluminum on Mylar and Kapton since it represented the simplest practical approach using an available coating technique to meet the objectives of this program.

Selection of coating thickness was a compromise between a thin, flexible coating that may have, inherently, a relatively high permeability and a thick coating that would inhibit the cryogenic flexibility of the polymeric film. Based on handling, visual observations, and limited test data on coated films, a thickness of $10,000 \text{ \AA}$ appeared reasonable as a starting point for evaluating concept feasibility. This amount of metal deposition was acceptable from both the application and diffusion bonding standpoint for the sandwich concept, and has a significant thickness for reducing permeability, and does not affect the handling of the polymer film. In order to evaluate the effect of coating thickness on permeability and film performance, a second thickness of $5,000 \text{ \AA}$ was arbitrarily selected.

3.2.2 Permeability Testing

The permeability of the metallized film concepts to helium gas at $+25^{\circ}\text{C}$ was determined with the film in a state of zero and 20% stressed condition. The tests were made using the same apparatus and procedures used in the preliminary film characterization studies (Paragraph 3.1.1).

The results of the permeability tests are presented in Tables XV and XVI. Table XV shows the individual test values of the stressed and unstressed films while Table XVI presents the average specific permeability rates.

TABLE XV SPECIFIC PERMEABILITY RATES OF PLAIN AND METALLIZED FILMS

Concept	Film Stress		Material	Film Thickness mils (mm)	Coating		Total Laminate Thickness, mils (mm)	Helium (1) Leak Rate cc/sec	Specific Permeability cc-mm/cm ² sec·cm Hg
	0%	20%			Material	Thickness, A			
Plain Film (3)	X		Mylar	.25 (.00635)	-	-	.25 (.00635)	2.3×10^{-3}	1.14×10^{-8}
	X		Mylar	.50 (.0127)	-	-	.50 (.0127)	2.4×10^{-5}	2.38×10^{-10}
	X		Kapton	.25 (.00635)	-	-	.25 (.00635)	7.5×10^{-3}	3.73×10^{-9}
	X		Kapton	.50 (.0127)	-	-	.50 (.0127)	4.0×10^{-5}	3.96×10^{-10}
	X		Kapton	1.00 (.0254)	-	-	1.00 (.0254)	-	2.49×10^{-9}
		X	Mylar	.25 (.00635)	-	-	.25 (.00635)	1.1×10^{-2}	5.48×10^{-8}
		X	Mylar	.50 (.0127)	-	-	.50 (.0127)	1.70×10^{-3}	1.68×10^{-8}
		X	Kapton	.25 (.00635)	-	-	.25 (.00635)	1.9×10^{-2}	9.5×10^{-8}
		X	Kapton	.50 (.0127)	-	-	.50 (.0127)	1.75×10^{-4}	1.73×10^{-9}
	Metallized Films (2) (Sputtered one side only)	X		Kapton	.25 (.00635)	10,000	Gold	.25 (.00635)	5.91×10^{-7}
X			Kapton	.50 (.0127)	5,000	Gold	.50 (.0127)	9.1×10^{-6}	9.0×10^{-11}
X			Kapton		10,000	Gold		7.3×10^{-6}	7.2×10^{-11}
X			Kapton		10,000	Aluminum		1.92×10^{-6}	1.90×10^{-11}
X								2.75×10^{-6}	2.73×10^{-11}
X								8.98×10^{-6}	8.89×10^{-11}
X								2.23×10^{-6}	2.21×10^{-11}
X								2.06×10^{-6}	2.04×10^{-11}
X		X						1.70×10^{-6}	1.68×10^{-11}
X		X						5.72×10^{-6}	5.66×10^{-11}
	X						1.29×10^{-5}	1.28×10^{-10}	
	X						3.55×10^{-6}	3.51×10^{-11}	
	X		Kapton	.50 (.0127)	10,000	Aluminum	.50 (.0127)	4.51×10^{-6}	4.97×10^{-11}

TABLE XV SPECIFIC PERMEABILITY RATES OF PLAIN AND METALLIZED FILMS (Continued)

Concept	Film Stress		Material	Film Thickness mils (mm)	Coating		Total Laminate Thickness, mils (mm)	Helium (1) Leak Rate cc/sec	Specific Permeability cc-mm/cm ² ·sec·cm Hg
	0%	20%			Material	Thickness, Å			
Metallized Films (Sputtered one side only)	X		Mylar	.50 (.0127)	Aluminum	10,000	.50 (.0127)	1.08 x 10 ⁻⁵	1.07 x 10 ⁻¹⁰
	X							7.48 x 10 ⁻⁶	7.41 x 10 ⁻¹¹
	X							7.04 x 10 ⁻⁶	6.97 x 10 ⁻¹¹
	X							6.09 x 10 ⁻⁶	6.03 x 10 ⁻¹¹
	X							4.58 x 10 ⁻⁶	4.53 x 10 ⁻¹¹
		X	Mylar	.50 (.0127)	Aluminum	10,000	.50 (.0127)	1.14 x 10 ⁻⁵	1.13 x 10 ⁻¹⁰
		X						5.94 x 10 ⁻⁶	5.88 x 10 ⁻¹¹
		X						1.04 x 10 ⁻⁵	7.26 x 10 ⁻¹⁰
		X						6.09 x 10 ⁻⁶	6.03 x 10 ⁻¹¹
		X						5.64 x 10 ⁻⁶	5.58 x 10 ⁻¹¹
		X	Kapton	.25 (.00635)	Aluminum	5,000	.25 (.00635)	5.13 x 10 ⁻⁶	2.54 x 10 ⁻¹¹
		X						2.51 x 10 ⁻⁶	1.24 x 10 ⁻¹¹
		X						4.22 x 10 ⁻⁶	2.09 x 10 ⁻¹¹
		X						8.69 x 10 ⁻⁶	4.30 x 10 ⁻¹¹
		X						1.32 x 10 ⁻⁶	6.5 x 10 ⁻¹²
	X	Kapton	.25 (.00635)	Aluminum	5,000	.25 (.00635)	4.18 x 10 ⁻⁶	2.07 x 10 ⁻¹¹	
	X						7.55 x 10 ⁻⁶	3.74 x 10 ⁻¹¹	
	X						6.45 x 10 ⁻⁶	3.19 x 10 ⁻¹¹	
	X						3.00 x 10 ⁻⁶	1.49 x 10 ⁻¹¹	
	X						8.65 x 10 ⁻⁶	4.28 x 10 ⁻¹¹	
Laminated Films (2) (Diffusion Bonded)	X		Kapton	.25 (.00635)	Gold	5,000	.50 (.0127)	4.33 x 10 ⁻⁸	4.3 x 10 ⁻¹³
	X							5.25 x 10 ⁻⁸	5.2 x 10 ⁻¹³
	X		Kapton	.25 (.00635)	Gold	5,000	.50 (.0127)	5.10 x 10 ⁻⁶	5.05 x 10 ⁻¹¹
	X							1.04 x 10 ⁻⁸	1.03 x 10 ⁻¹³
X								3.84 x 10 ⁻¹³	

TABLE XV SPECIFIC PERMEABILITY RATES OF PLAIN AND METALLIZED FILMS (Continued)

Concept	Film Stress		Material	Film Thickness mils (mm)	Coating		Total Laminate Thickness, mils (mm)	Helium (1) Leak Rate cc/sec	Specific Permeability cc-mm/cm ² sec-cm Hg		
	0%	20%			Material	Thickness, Å					
Laminated Films (2) (Diffusion Bonded)		X	Kapton	.25 (.00635)	Gold	5,000	.50 (.0127)	1.87 x 10 ⁻⁶	1.85 x 10 ⁻¹¹		
		X						→	→	3.37 x 10 ⁻⁸	3.33 x 10 ⁻¹³
		X						→	→	6.01 x 10 ⁻⁶	5.95 x 10 ⁻¹¹
		X						→	→	1.17 x 10 ⁻⁵	1.16 x 10 ⁻¹⁰
		X						→	→	1.87 x 10 ⁻⁶	1.85 x 10 ⁻¹¹
		X						→	→	1.3 x 10 ⁻⁸	1.29 x 10 ⁻¹³
		X						→	→	5.7 x 10 ⁻¹⁰	5.65 x 10 ⁻¹⁵
		X						→	→	6.42 x 10 ⁻⁶	6.35 x 10 ⁻¹¹
		X						→	→	7.01 x 10 ⁻⁷	6.94 x 10 ⁻¹²
		X						→	→	2.07 x 10 ⁻⁸	2.05 x 10 ⁻¹³
		X						→	→	4.51 x 10 ⁻⁸	4.46 x 10 ⁻¹³
		X						→	→	2.16 x 10 ⁻⁸	2.14 x 10 ⁻¹³
		X						→	→	1.42 x 10 ⁻⁶	1.40 x 10 ⁻¹¹
		X						→	→	2.13 x 10 ⁻⁷	2.11 x 10 ⁻¹²
		X						→	→	5.39 x 10 ⁻⁶	5.33 x 10 ⁻¹¹
	X	X	Kapton	.25 (.00635)	Gold	5,000	1.00 (.0254)	8.04 x 10 ⁻⁹	1.59 x 10 ⁻¹³		
	X	X						→	→	3.02 x 10 ⁻¹⁰	5.95 x 10 ⁻¹⁵
	X	X						→	→	1.0 x 10 ⁻⁷	1.98 x 10 ⁻¹²
	X	X						→	→	9.8 x 10 ⁻¹⁰	1.94 x 10 ⁻¹⁴
	X	X						→	→	2.6 x 10 ⁻⁸	5.15 x 10 ⁻¹³
	X	X						→	→	1.0 x 10 ⁻⁵	1.98 x 10 ⁻¹⁰
	X	X						→	→	1.37 x 10 ⁻⁸	2.71 x 10 ⁻¹³
	X	X						→	→	5.0 x 10 ⁻⁹	9.90 x 10 ⁻¹⁴
	X	X						→	→	2.99 x 10 ⁻⁸	5.92 x 10 ⁻¹³
	X	X						→	→	2.43 x 10 ⁻⁸	4.81 x 10 ⁻¹³
	X	X						→	→	6.4 x 10 ⁻⁹	1.27 x 10 ⁻¹³
	X	X						→	→	2.4 x 10 ⁻⁹	4.75 x 10 ⁻¹⁴
	X	X						→	→	1.5 x 10 ⁻⁹	2.98 x 10 ⁻¹⁴
	X	X						→	→	1.4 x 10 ⁻⁹	2.78 x 10 ⁻¹⁴
	X	X						→	→	4.0 x 10 ⁻⁹	7.9 x 10 ⁻¹⁴
	X	X	→	→	9.46 x 10 ⁻⁹	1.87 x 10 ⁻¹³					
	X	X	→	→	4.66 x 10 ⁻¹⁰	9.2 x 10 ⁻¹⁵					

TABLE XV SPECIFIC PERMEABILITY RATES OF PLAIN AND METALLIZED FILMS (Continued)

Concept	Film Stress		Material	Film Thickness mils (mm)	Coating		Total Laminate Thickness, mils (mm)	Helium Leak Rate cc/sec	Specific Permeability cc-mm/cm ² -sec-cm Hg
	0%	20%			Material	Thickness, A			
Laminated Films (2) (Diffusion Bonded)		X	Kapton	.50 (.0127)	Gold	10,000	1.00 (.0254)	4.95 x 10 ⁻⁹	9.8 x 10 ⁻¹⁴
		X						7.37 x 10 ⁻⁹	1.46 x 10 ⁻¹³
		X						3.05 x 10 ⁻⁸	6.04 x 10 ⁻¹³
		X						4.71 x 10 ⁻⁹	9.33 x 10 ⁻¹⁴
		X		Kapton	.50 (.0127)	Gold	10,000	1.00 (.0254)	1.93 x 10 ⁻⁸
Laminated Film (4) (Vacuum Deposited- Diffusion Bonded)	X		Kapton	.25 (.00635)	Gold	10,000	.50 (.0127)	1.16 x 10 ⁻⁵	1.15 x 10 ⁻¹⁰
	X							2.17 x 10 ⁻⁵	2.15 x 10 ⁻¹⁰
	X							9.76 x 10 ⁻⁷	9.66 x 10 ⁻¹²
	X							3.74 x 10 ⁻⁸	3.70 x 10 ⁻¹³
	X							4.76 x 10 ⁻⁶	4.71 x 10 ⁻¹¹
		X						8.4 x 10 ⁻⁶	8.31 x 10 ⁻¹¹
		X						1.67 x 10 ⁻⁵	1.65 x 10 ⁻¹⁰
		X						1.41 x 10 ⁻⁵	1.40 x 10 ⁻¹⁰
		X						8.8 x 10 ⁻⁶	8.7 x 10 ⁻¹¹
		X		Kapton	.50 (.00635)	Gold	10,000	1.00 (.0254)	1.12 x 10 ⁻⁶
	X							3.02 x 10 ⁻⁶	5.98 x 10 ⁻¹¹
	X							3.33 x 10 ⁻⁶	6.59 x 10 ⁻¹¹
	X							2.76 x 10 ⁻⁶	5.46 x 10 ⁻¹¹
	X							1.94 x 10 ⁻⁶	3.84 x 10 ⁻¹¹
	X							7.01 x 10 ⁻⁶	1.39 x 10 ⁻¹⁰
		X						4.7 x 10 ⁻⁶	9.3 x 10 ⁻¹¹
		X						1.2 x 10 ⁻⁵	2.38 x 10 ⁻¹⁰
		X						8.21 x 10 ⁻⁶	1.63 x 10 ⁻¹⁰
		X						9.87 x 10 ⁻⁶	1.95 x 10 ⁻¹⁰
		X						7.67 x 10 ⁻⁶	1.52 x 10 ⁻¹⁰

(1) Based on a test area of 38.5 in² (248.3 cm²).

(2) Sputtered gold and aluminum coatings.

(3) Plain films; values are average readings taken from Task I.

(4) Vacuum deposited gold coatings.

TABLE XVI-SUMMARY - AVERAGE SPECIFIC PERMEABILITY RATES AT +70°F (21°C)

Concept	Material	Film Stress		Film Thickness, mils (mm)	Coating		Total Specimen Thickness mils (mm)	Specific Permeability of Helium (cc-mm/cm ² sec-cm Hg)
		0%	20%		Material	Thickness, Å		
Plain Film	Mylar	X	X	.25 (.00635)	-	-	.25 (.00635)	11.4 x 10 ⁻⁹
		X	X	.25 (.00635)	-	-	.25 (.00635)	54.8 x 10 ⁻⁹
		X	X	.50 (.0127)	-	-	.50 (.0127)	0.24 x 10 ⁻⁹
		X	X	.50 (.0127)	-	-	.50 (.0127)	16.8 x 10 ⁻⁹
		X	X	.25 (.00635)	-	-	.25 (.00635)	3.73 x 10 ⁻⁹
	Kapton	X	X	.25 (.00635)	-	-	.25 (.00635)	95.0 x 10 ⁻⁹
		X	X	.50 (.0127)	-	-	.50 (.0127)	0.40 x 10 ⁻⁹
		X	X	.50 (.0127)	-	-	.50 (.0127)	1.73 x 10 ⁻⁹
		X	X	1.00 (.0254)	-	-	1.00 (.0254)	2.49 x 10 ⁻⁹
		X	X	.25 (.00635)	Gold	10,000	.25 (.00635)	0.29 x 10 ⁻¹¹
Metallized (Sputtered One Side Only)	Kapton	X	X	.50 (.0127)	"	5,000	.50 (.0127)	9.0 x 10 ⁻¹¹
		X	X	.50 (.0127)	Gold	10,000	.50 (.0127)	7.2 x 10 ⁻¹¹
		X	X	.50 (.0127)	Aluminum	10,000	.50 (.0127)	3.55 x 10 ⁻¹¹
		X	X	.50 (.0127)	"	"	.50 (.0127)	5.72 x 10 ⁻¹¹
		X	X	.50 (.0127)	"	"	.50 (.0127)	7.13 x 10 ⁻¹¹
	Mylar	X	X	.50 (.0127)	"	"	.50 (.0127)	20.3 x 10 ⁻¹¹
		X	X	.25 (.00635)	"	10,000	.25 (.00635)	2.1 x 10 ⁻¹¹
		X	X	.25 (.00635)	Aluminum	5,000	.25 (.00635)	2.95 x 10 ⁻¹¹
		X	X	.25 (.00635)	Gold	5,000	.25 (.00635)	3.59 x 10 ⁻¹³
		X	X	.25 (.00635)	"	5,000	.25 (.00635)	426.0 x 10 ⁻¹³
Laminated Film (Sputtered Coating-Diffusion Bonded)	Kapton	X	X	.25 (.00635)	"	10,000	.50 (.0127)	1.68 x 10 ⁻¹³
		X	X	.25 (.00635)	"	10,000	.50 (.0127)	139.0 x 10 ⁻¹³
		X	X	.50 (.0127)	"	5,000	1.00 (.0254)	5.36 x 10 ⁻¹³
		X	X	.50 (.0127)	"	5,000	1.00 (.0254)	3.61 x 10 ⁻¹³
		X	X	.50 (.0127)	"	10,000	1.00 (.0254)	0.73 x 10 ⁻¹³
	Kapton	X	X	.50 (.0127)	Gold	10,000	1.00 (.0254)	2.65 x 10 ⁻¹³
		X	X	.25 (.00635)	Gold	10,000	.50 (.0127)	7.7 x 10 ⁻¹¹
		X	X	.25 (.00635)	"	10,000	.50 (.0127)	9.7 x 10 ⁻¹¹
		X	X	.50 (.0127)	"	10,000	1.00 (.0254)	7.15 x 10 ⁻¹¹
		X	X	.50 (.0127)	"	10,000	1.00 (.0254)	16.8 x 10 ⁻¹¹

(1) Single Values

The test specimens can be classified into four categories: (1) plain film, (2) film metallized one-side only, (3) sputtered coating followed by diffusion bonding, and (4) vacuum deposited coating followed by diffusion bonding. Each of these materials are discussed in the following paragraphs.

- a. Plain Film - The plain Mylar and Kapton films were tested primarily to serve as control with most of the data coming from Task I, Section 3.1. Restating some of the conclusions from Section 3.1: the Kapton film is less permeable to helium gas than the Mylar films of comparable thickness. In both types of films the 0.25 mil thick film is significantly more permeable and is less uniform than a 0.50 mil film. Stressing the plain film (20% biaxial) increases the helium permeability by 1 to 3 times over the non-stressed film.

- b. Metallized Film (one side only) - Samples of Mylar and Kapton were sputter-coated with gold and aluminum to assess the effectiveness of such a coating to reduce permeability. Tests have demonstrated (References 4 and 6) that vacuum metallizing alone is not an effective means of reducing the gas permeability rate through a thin polymeric film. Sputtering on the other hand, produces a more dense and uniform coating and it was anticipated that reduced permeability would be realized. The results show that a single sputtered coating does reduce the helium permeability by approximately 2 orders of magnitude over the plain film with no significant difference being noted between a gold or aluminum coating. In addition to reducing the permeability of the film, the difference in permeability rates between the stressed and non-stressed film was reduced slightly.

- c. Laminated Film (Sputtered Coating - Diffusion Bonded) - Diffusion bonding of sputtered coatings reduces the film helium permeability by at least four magnitudes over the plain film and appears independent of the thickness of the metallized coating.

As stated earlier, the plain 1/2 mil thick films have a slightly lower permeability rate than the 1/4 mil thick films due to improved uniformity and this is still evident in the metallized and diffusion bonded film specimens made from the two film thicknesses.

Applying a 20% biaxial stress to the films increases the helium permeability of each specimen type, whether plain, metallized or diffusion bonded. Stressing a diffusion bonded specimen does not delaminate or appear to deteriorate the diffusion bond but in some cases increased the helium permeability by two orders of magnitude over the unstressed film. Even so, the stressed diffusion bonded specimens had a lower permeability than the unstressed metallized film.

- d. Laminated Film (Vacuum Deposited Coating - Diffusion Bonded) - Diffusion bonding films having a vacuum deposited coating rather than a sputtered coating is not an effective method of reducing permeability. The helium permeability of a diffusion bonding of film with vacuum deposited coating is in the range of 10^{-11} cc-mm/cm²sec cm Hg, which is the same magnitude as the unbonded film with a sputtered coating on one side. Consequently, there is little advantage to diffusion bonding two films when the same results can be obtained by merely applying a sputtered coating rather than a vacuum deposited coating. However, one important trend should be noted from these results. A thin polymeric film with a vacuum deposited coating on one side has a helium permeability rate in the same range as that of plain film or 10^{-9} cc-mm/cm²sec. cm Hg. Diffusion bonding the vacuum metallized film reduces the permeability by 2 orders of magnitude or to 10^{-11} cc-mm/cm² sec. cm Hg. Similarly, diffusion bonding a film with a sputtered metallized coating reduces the permeability from 10^{-11} to 10^{-13} or 2 orders of magnitude. This demonstrates diffusion bonding two metallized films together is an effective method of reducing gas permeation but the degree of reduction is highly dependent upon the quality of the metallized coatings. Evidently the porosity of the vacuum deposited coating was sufficiently high that the pore could not be effectively sealed.

d. (cont.)

The thickness of the metallized coating, within the range tested, had no significant effect on the permeability. That is, the 5000Å coatings were just as effective as the 10,000Å coating, indicating that the break-off point is somewhat less than 5,000Å.

3.2.3 Film Flexibility

Twist-flex specimens were prepared from each of the 10 materials shown in Table XIV. In addition, several control samples were tested to provide data comparisons. The specimens and test procedures were the same as those described in Section 3.1.2. The data is presented in Table XVII. All testing was conducted at -320°F (-195°C).

The presence of a metallized surface on the polymeric films, either sputtered or vacuum deposited and whether or not it has been diffusion bonded into a laminate, reduces the Twist-flex life of the film. Diffusion bonding itself, however, does not appear to influence the Twist-flex life. For example, 1/4 mil Kapton laminate with 10,000Å of sputtered gold (total laminate thickness = 1/2 mil) had an endurance limit of 50-60 cycles, while an unlaminated sample of the same metallized film (total thickness = 1/4 mil) went less than 75 cycles. The diffusion bonded sample being thicker should have had a substantially lower threshold, but this was not the case. A similar comparison was obtained with the 1/2 mil Kapton film. A similar trend seemed to be present with the vacuum-metallized diffusion-bonded specimens, but the data scatter makes it difficult to assess.

The 1/4 mil film samples sputtered with aluminum had a lower threshold than the same film sputtered with gold. The 1/4 mil Kapton film sputtered with aluminum had a damage threshold at about 40 cycles compared to a threshold value of 75 cycles for sputtered gold on 1/4 mil Kapton. Comparing the results shown in Table XVII, it appears that both metallizing processes degrade the twist-flex life with the vacuum metallizing, causing more scatter than sputtering, although the latter process causes more degradation.

TABLE XVII-TWIST-FLEX RESULTS AT -320°F (-195°C)

Concept	Specimen No.	Film	Film Thickness mils (mm)	Coating		Total Specimen Thickness mils (mm)	Cycles	Results	Leak Rate After Test (cc/sec)	
				Material	Thickness A					
Plain Film	TIK-1	Kapton	1.0 (.0254)	-	-	1.0 (.0254)	80	Torn	-	
	-2		1.0 (.0254)	-	-	1.0 (.0254)	65	Torn	-	
	-3		1.0 (.0254)	-	-	1.0 (.0254)	60	Torn	-	
	-4		1.0 (.0254)	-	-	1.0 (.0254)	90	Intact	0.19	
	-5	Kapton	.5 (.0127)	-	-	.5 (.0127)	125 225	Intact Torn	- -	
Metallized Film ① (Sputtered one side only)	TIK-6	Kapton	.5 (.0127)	Gold	5,000	.5 (.0127)	5	Torn ②	-	
	-7		.25 (.00635)	Gold	10,000	.25 (.00635)	75	Torn	-	
	-8	Kapton	.5 (.0127)	Gold	2,000 ③	.5 (.0127)	120 140	Intact Torn	- -	
	T1/4K5KÄAL-1		Kapton	.25 (.00635)	Aluminum	5,000	.25 (.00635)	25	Intact	-
		-2						50	Torn	-
		-3						40	Intact	-
		-4						45	Small tear	5.4
		-5						45 40	" "	5.5 86.3
T1/2K10KÄAL-1			.25 (.00635)		5,000	.25 (.00635)	35	Small tear	130.0	
	-2						25	Torn	-	
	-3						10	Torn	-	
	-4						5	Torn	-	
	-5						5	Small tear	>200	
	-6	Kapton	.5 (.0127)	Aluminum	10,000	.5 (.0127)	3 5	Small tear Intact Small tear	- - 19.2	

TABLE XVII TWIST-FLEX RESULTS AT -320°F (-195°C) (Continued)

Concept	Specimen No.	Film	Film Thickness mils (mm)	Coating		Total Specimen Thickness mils (mm)	Cycles	Results	Leak Rate After Test (cc/sec)
				Material	Thickness Å				
Metallized Film ① (Sputtered one side only)	T1/4M5KAAAL-1	Mylar	.25 (.00635)	Aluminum	5,000	.25 (.00635)	15	Intact	-
	-2						25	Torn	-
	-3						15	Intact	-
	-4						25	Small tear	1.8
	-5	Mylar	.25 (.00635)	Aluminum	5,000	.25 (.00635)	40	Intact	-
	-6						50	Torn	86.0
Metallized Film ⑤ (Vacuum Deposited one side only)	T1/2M10KAAAL-1	Mylar	.50 (.0127)	Aluminum	10,000	.50 (.0127)	5	Intact	-
	-2						10	Torn	-
	-3						5	Torn	-
	-4						5	Small tear	18.8
	-5	Mylar	.50 (.0127)	Aluminum	10,000	.50 (.0127)	10	Intact	-
	-6						15	Small tear	15.3
Metallized Film ⑤ (Vacuum Deposited one side only)	T1/4KV10KAAu-1	Kapton	.25 (.00635)	Gold	10,000	.25 (.00635)	35	Intact	-
	-2	Kapton	.25 (.00635)	Gold	10,000	.25 (.00635)	45	Torn	> 300
							31	Torn	> 200
	T1/2KV10KAAu-1	Kapton	.50 (.0127)	Gold	10,000	.50 (.0127)	60	Intact	-
	-2	Kapton	.50 (.0127)	Gold	10,000	.50 (.0127)	80	Torn	-
							40	Torn	-

TABLE XVII TWIST-FLEX RESULTS AT -320°F (-195°C) (Continued)

Concept	Specimen No.	Film	Film Thickness mils (mm)	Coating		Total Specimen Thickness mils (mm)	Cycles	Results	Leak Rate After Test (cc/sec)
				Material	Thickness Å				
Laminated Films - (Sputtered Coating-Diffusion Bonded) ① ④	T1/4KSGS-1	Kapton	.25 (.00635)	Gold	5,000	.50 (.0127)	90	Torn	-
	-2						1	Torn ②	-
	-3						80	Torn	-
	-4				5,000		85	Intact	0.23
	-5				10,000		75	Intact (Inflation)	2.61
	T1/4K10GS-1						50	Torn ②	-
	-2						75	Torn	-
	-3						70	Small hole	200.0
	-4						60	Intact (Inflation)	15.0
	-5						65	Torn	-
	T1/2K5GS-1	Kapton	.25 (.00635)	Gold	10,000	.50 (.0127)	25	Torn	-
	-2						10	Small hole	65.0
	-3						5	Tear, one ply	2.1
	-4						6	Small tear	150.0
	-5						4	Intact	7.14 x 10 ⁻⁴
-6						4	Intact	6.4	
T1/2K10GS-1	Kapton	.50 (.0127)	Gold	10,000	1.00 (.0254)	10	3 tears	128.0	
-2						5	2 tears	59.2	
-3						6	Small tear	33.9	
-4						5	Small tear	42.3	
-5						10	Torn	-	
Laminated Films ⑤ (Vacuum Deposited-Diffusion Bonded) ④	T1/4K10GV-1	Kapton	.25 (.00635)	Gold	10,000	.50 (.0127)	15	Intact	-
	-2						25	Torn	-
	-3						5	Intact	-
	-4						10	Small tear	21.0
	-5						10	Small tear	5.6
						10	Intact	-	
						12	Intact	0.09	
						25	Intact	-	
						30	Intact	14.8	

TABLE XVII TWIST-FLEX RESULTS AT -320°F (-195°C) (Continued)

Concept	Specimen No.	Film	Film Thickness mils (mm)	Coating		Total Specimen Thickness mils (mm)	Cycles	Results	Leak Rate After Test (cc/sec)
				Material	Thickness Å				
Laminated Films ⑤ (Vacuum Deposited - Diffusion Bonded) ④ (Cont'd)	T1/2K10GV-1	Kapton	.50 (.0127)	Gold	10,000	1.00 (.0254)	30	Intact	-
	-2						40	Torn	-
	-3						10	Torn	-
	-4						10	Intact	-
	-5						20	Torn	-
							10	Intact	-
							15	Small tear	> 200
							10	Intact	-
							15	Torn	-

- ① Coating applied by sputtering.
- ② Bushing freeze-up causing shaft to bind causes tear from short side to long side or the shearing off of the taped edge.
- ③ 1000 Å gold both sides vacuum deposited.
- ④ Thickness of diffusion bonded specimens is twice the base film thickness.
- ⑤ Coating applied by vacuum deposition.

However, in applying the aluminum coating, a higher particle energy level was required in the sputtering operation to promote good adherence of the aluminum and could account for the greater degradation.

All the metallized films had a lower threshold value than the plain films which indicated that metallizing by either process (i.e. vacuum-deposition or sputtering) deteriorates the flexibility of the film. Therefore, in order to reduce film permeability it appears that a sacrifice in film flexibility will result. It is significant to note in Figure 25 that metallized diffusion bonded Kapton film, even though it is degraded by metallization has a twist-flex life which is as good as Mylar film of the same thickness.

3.2.4 Bond Strength Determination

Butt and lap joint specimens were prepared from each of the metallized and diffusion bonded film concepts using the basic joint configurations given in Section 3.1.3. GT-100 and GT-300 adhesives were again used. For the sputtered aluminum specimens, the lap joints were prepared by bonding the two metallized surfaces together with GT-100. These were the only samples in which the primary bond was between two metallized coatings. The butt joints on the metallized films had one GT-300 doubler bonded to the metallized surface and a second bonded to the plain film side. The joint concepts are shown in Figure 18.

The results of the bond tests are shown in Table XVIII. The predominant mode of failure in all samples, with the exception of the B1/2KSB10KAAu and L1/2KSB10KAAu series, was in the film itself. The mode of failure of the B1/2KSB10KAAu and L1/2KSB10KAAu series (diffusion bonded 10,000A gold on 1/2 mil Kapton) were termed joint failures since the films separated in the joint region at the diffusion bonded layer. The stresses in the joints of these specimens were considerably higher than that in other samples which accounts for the failure of the diffusion bond. The tests were conclusive in showing that very high stresses can be developed in the films prior to bond failure and that conventional bladder fabrication techniques would be applicable.

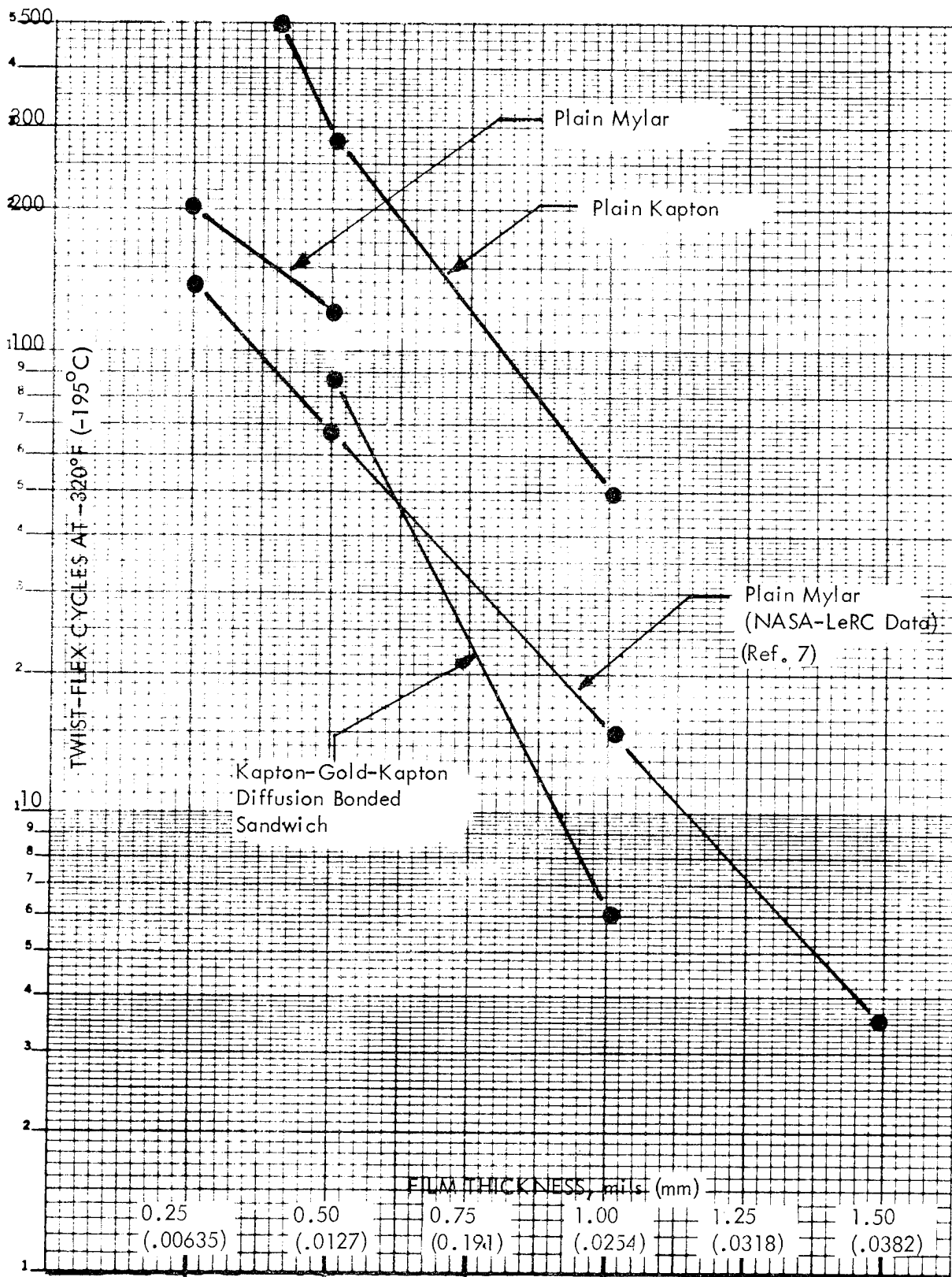

FIGURE 25 - RELATIONSHIP OF FILM THICKNESS TO TWIST-FLEX CYCLIC LIFE AT -320°F (-195°C)

TABLE XVIII BOND STRENGTH TENSILE TESTS - +70°F (21°C)

Specimen No.	Gage Length, in. (cm)	Load Rate, in/min(cm/min)	Lap, in. (cm)	Width, in. (cm)	Load, lbs (Kg)	Film Stress, Ksi (Kg/Sq. cm)	Lap Stress, Psi (Kg/Sq. cm)	Failure Location
.25 mil (.00635 mm) Kapton sputtered with 5000 Å Aluminum on one side.								
B1/4K5KAA ^o -1	10.0 (25.4)	2.0 (5.08)	1/2* (1.27)*	1.0 (2.54)	8.75 (3.99)	BUTT JOINT	8.25 (.58)	Film
-2	→	→	→	→	5.00 (2.27)	35.0 (2460.7)	5.00 (.35)	Film
-3	→	→	→	→	6.25 (1.29)	20.0 (1406.1)	6.25 (.44)	Adjacent
-4	→	→	→	→	3.25 (1.47)	25.0 (1757.6)	3.25 (.23)	Film
-5	→	→	→	→	6.25 (1.29)	13.0 (914.0)	6.25 (.44)	Film
L1/4K5KAA ^o -1	10.0 (25.4)	1.0 (2.54)	1/2 (1.27)	1.0 (2.54)	4.75 (2.15)	LAP JOINT	9.50 (.67)	Film
-2	→	→	→	→	5.50 (2.50)	19.0 (1335.9)	11.00 (.77)	Film
-3	→	→	→	→	6.25 (1.29)	22.0 (1546.7)	12.50 (.88)	Adjacent
-4	→	→	→	→	4.75 (2.15)	25.0 (1757.6)	9.50 (.67)	Film
-5	→	→	→	→	5.75 (2.61)	19.0 (1335.9)	11.50 (.81)	Film
.50 mil (.0127 mm) Kapton sputtered with 10,000 Å Aluminum on one side.								
B1/2K10KAA ^o -1	8.0 (20.3)	1.0 (2.54)	1/2* (1.27)*	1.0 (2.54)	11.00 (4.99)	BUTT JOINT	11.00 (.77)	Film
-2	→	→	→	→	10.75 (4.88)	22.0 (1546.7)	10.75 (.76)	Film
-3	→	→	→	→	11.75 (5.33)	21.5 (1511.6)	11.75 (.83)	Film
-4	→	→	→	→	9.75 (4.42)	23.5 (1652.2)	9.75 (.68)	Film
-5	→	→	→	→	10.75 (4.88)	19.5 (1371.0)	10.75 (.76)	Grip
L1/2K10KAA ^o -1	8.0 (20.3)	1.0 (2.54)	1/2 (1.27)	1.0 (2.54)	12.25 (5.56)	LAP JOINT	24.5 (1.68)	Film
-2	→	→	→	→	11.75 (5.33)	24.5 (1722.5)	23.5 (1.62)	Film
-3	→	→	→	→	14.00 (6.35)	23.5 (1652.2)	28.0 (1.97)	Film
-4	→	→	→	→	13.75 (6.24)	28.0 (1968.6)	27.5 (1.93)	Film
-5	→	→	→	→	11.50 (5.22)	27.5 (1933.4)	23.0 (1.61)	Film

*Each side (overall) lap area = 1 sq. in. (6.45 sq. cm)

TABLE XVIII BOND STRENGTH TENSILE TESTS - +70°F (21°C) (Continued)

Specimen No.	Gage Length, in. (cm)	Load Rate, in./min(cm/min)	Lap, In. (cm)	Width, in. (cm)	Load, lbs (Kg)	Film Stress, Ksi (Kg/Sq. cm)	Lap Stress, Psi (Kg/Sq. cm)	Failure Location
.25 mil (.00635 mm) Mylar sputtered with 5000 Å Aluminum on one side.								
B1/4M5KAA-1	8.0 (20.3)	1.0 (2.54)	1/2* (1.27)*	1.0 (2.54)	5.50 (2.50)	BUTT JOINT		
-2	↓	↓	↓	↓	5.25 (2.38)	22.0 (1546.7)	5.50 (.39)	Film
-3	↓	↓	↓	↓	5.25 (2.38)	21.0 (1476.5)	5.25 (.37)	Film
-4	↓	↓	↓	↓	4.50 (2.04)	21.0 (1476.5)	5.25 (.37)	Film
-5	↓	↓	↓	↓	5.00 (2.27)	18.0 (1265.5)	4.50 (.32)	Film
						20.0 (1406.1)	5.00 (.35)	Adjacent
LAP JOINT								
L1/4M5KAA-1	8.0 (20.3)	1.0 (2.54)	1/2 (1.27)	1.0 (2.54)	4.75 (2.15)	19.0 (1335.8)	9.50 (.67)	Grip
-2	↓	↓	↓	↓	5.25 (2.38)	21.0 (1476.5)	10.50 (.74)	Film
-3	↓	↓	↓	↓	5.25 (2.38)	21.0 (1476.5)	10.50 (.74)	Film
-4	↓	↓	↓	↓	5.50 (2.50)	22.0 (1546.7)	11.00 (.77)	Film
-5	↓	↓	↓	↓	5.50 (2.50)	22.0 (1546.7)	11.00 (.77)	Film
BUTT JOINT								
.50 mil (.0127 mm) Mylar sputtered with 10,000 Å Aluminum on one side.								
B1/2M10KAA-1	8.0 (20.3)	1.0 (2.54)	1/2* (1.27)*	1.0 (2.54)	13.25 (6.01)	26.5 (1863.1)	13.25 (.92)	Film
-2	↓	↓	↓	↓	13.00 (6.03)	26.6 (1870.2)	13.30 (.94)	Film
-3	↓	↓	↓	↓	12.25 (5.56)	24.5 (1722.5)	12.25 (.86)	Film
-4	↓	↓	↓	↓	12.00 (5.44)	24.0 (1687.4)	12.00 (.84)	Adjacent
-5	↓	↓	↓	↓	12.60 (5.72)	25.2 (1771.7)	12.60 (.89)	Film
BUTT JOINT								
LAP JOINT								
L1/2M10KAA-1	8.0 (20.3)	1.0 (2.54)	1/2 (1.27)	1.0 (2.54)	10.50 (4.77)	21.0 (1476.5)	21.0 (1.48)	Grip
-2	↓	↓	↓	↓	11.75 (5.33)	23.5 (1652.2)	23.5 (1.65)	Grip
-3	↓	↓	↓	↓	13.00 (5.90)	26.0 (1828.0)	26.0 (1.83)	Film
-4	↓	↓	↓	↓	10.30 (4.68)	20.6 (1448.3)	20.6 (1.45)	Film
-5	↓	↓	↓	↓	11.55 (5.24)	23.1 (1624.1)	23.1 (1.62)	Film

*Each side (overall) lap area = 1 sq. in. (6.45 sq. cm).

TABLE XVIII BOND STRENGTH TENSILE TESTS - +70°F (21°C) (Continued)

Specimen No.	Gage Length, in. (cm)	Load Rate, in/min (cm/min)	Lap, in. (cm)	Width, in. (cm)	Load, lbs (Kg)	Film Stress, Ksi (Kg/Sq. cm)	Lap Stress, Psi (Kg/Sq. cm)	Failure Location
.25 mil (.00635 mm) Kapton vacuum deposited with 10,000 Å Gold on one side and diffusion bonded. Total Film Thickness = .50 mil (.0127 mm)								
B1/4KVB10KAAu-1	5.5 (13.79)	1.0 (2.54)	1/2 (1.27)	1.0 (2.54)	12.5 (5.69)	BUTT JOINT		
-2	→	→	→	→	11.0 (4.99)	25.0 (1757.7)	12.5 (.88)	Film
-3	→	→	→	→	11.0 (4.99)	22.0 (1546.7)	11.0 (.77)	Film
-4	→	→	→	→	11.0 (4.99)	22.0 (1546.7)	11.0 (.77)	Film
-5	→	→	→	→	11.0 (4.99)	22.0 (1546.7)	11.0 (.77)	Film
					11.0 (4.99)	22.0 (1546.7)	11.0 (.77)	Film
LAP JOINT								
L1/4KVB10KAAu-1	5.5 (13.79)	1.0 (2.54)	1/2 (1.27)	1.0 (2.54)	12.0 (5.44)	24.0 (1687.4)	24.0 (1.69)	Film
-2	→	→	→	→	11.6 (5.26)	23.2 (1631.1)	23.2 (1.63)	Film
-3	→	→	→	→	11.4 (5.17)	22.8 (1603.0)	22.8 (1.60)	Film
-4	→	→	→	→	9.4 (4.26)	18.8 (1321.8)	18.8 (1.32)	Film
-5	→	→	→	→	13.5 (6.12)	27.0 (1898.3)	27.0 (1.90)	Film
BUTT JOINT								
.50 mil (.0127 mm) Kapton vacuum deposited with 10,000 Å Gold on one side and diffusion bonded. Total Film Thickness = .50 mil (.0127 mm)								
B1/2KVB10KAAu-1	5.5 (13.79)	1.0 (2.54)	1/2 (1.27)	1.0 (2.54)	19.8 (8.98)	19.8 (1392.1)	19.8 (1.39)	Film
-2	→	→	→	→	21.5 (9.75)	21.5 (1511.6)	21.5 (1.51)	Film
-3	→	→	→	→	20.2 (9.16)	20.2 (1420.2)	20.2 (1.42)	Film
-4	→	→	→	→	17.0 (7.71)	17.0 (1195.2)	17.0 (1.19)	Film
-5	→	→	→	→	24.0 (10.88)	24.0 (1687.4)	24.0 (1.69)	Joint
LAP JOINT								
L1/2KVB10KAAu-1	5.5 (13.79)	1.0 (2.54)	1/2 (1.27)	1.0 (2.54)	23.5 (10.66)	23.5 (1652.2)	47.0 (3.30)	Film
-2	→	→	→	→	22.0 (9.98)	22.0 (1546.7)	44.0 (3.09)	Joint
-3	→	→	→	→	19.3 (8.75)	19.3 (1356.9)	38.6 (2.71)	Adjacent
-4	→	→	→	→	22.7 (10.30)	22.7 (1596.0)	45.4 (3.19)	Film
-5	→	→	→	→	22.0 (9.98)	22.0 (1546.7)	44.0 (3.09)	Joint

TABLE XVIII BOND STRENGTH TENSILE TESTS - +70°F (21°C) (Continued)

Specimen No.	Gage Length, in. (cm)	Load Rate, in./min (cm./min)	Lap, in. (cm)	Width, in. (cm)	Load, lbs (Kg)	Film Stress, Ksi (Kg/Sq. cm)	Lap Stress, Psi (Kg/Sq. cm)	Failure Location
.50 (.0127 mm) Kapton sputtered with 5000 Å Gold on one side and diffusion bonded. Total Film Thickness = .50 mil (.0127 mm)								
B1/2KSB5KAAu-1	5.5 (13.79)	1.0 (2.54)	1/2*(1.27)*	1.0 (2.54)	25.0 (11.24)	BUTT JOINT	25.0 (1.75)	Joint
-2	→	→	→	→	25.0 (11.24)		25.0 (1.75)	Film
-3	→	→	→	→	25.7 (11.66)		25.7 (1.80)	Adjacent
-4	→	→	→	→	24.7 (11.20)		24.7 (1.73)	Joint
-5	→	→	→	→	22.5 (10.21)		22.5 (1.58)	Film
L1/2KSB5KAAu-1								
-1	5.5 (13.79)	1.0 (2.54)	1/2 (1.27)	1.0 (2.54)	17.0 (7.71)	LAP JOINT	34.0 (2.39)	Joint
-2	→	→	→	→	17.0 (7.71)		34.0 (2.39)	Film
-3	→	→	→	→	20.6 (9.34)		41.2 (2.88)	Joint
-4	→	→	→	→	21.6 (9.80)		43.2 (3.04)	Film
-5	→	→	→	→	19.2 (8.71)		38.4 (2.70)	Joint
.50 mil (.0127 mm) Kapton sputtered with 10,000 Å Gold on one side and diffusion bonded. Total Film Thickness = 1 mil (.0254 mm)								
B1/2KSB10KAAu-1	5.5 (13.79)	1.0 (2.54)	1/2*(1.27)*	1.0 (2.54)	23.50 (10.66)	BUTT JOINT	23.50 (1.65)	Film
-2	→	→	→	→	26.75 (12.13)		26.75 (1.87)	Joint
-3	→	→	→	→	15.25 (6.92)		15.25 (1.07)	Film
-4	→	→	→	→	26.75 (12.13)		26.75 (1.87)	Joint
-5	→	→	→	→	26.50 (12.02)		26.50 (1.86)	Joint
L1/2KSB10KAAu-1								
-1	5.5 (13.79)	1.0 (2.54)	1/2 (1.27)	1.0 (2.54)	15.50 (7.03)	LAP JOINT	31.00 (2.18)	Joint
-2	→	→	→	→	13.75 (6.24)		27.50 (1.93)	Joint
-3	→	→	→	→	19.50 (8.85)		39.00 (2.74)	Joint
-4	→	→	→	→	22.75 (10.32)		45.50 (3.20)	Joint
-5	→	→	→	→	22.50 (10.21)		45.00 (3.16)	Joint

*Each side (overall) lap area = 1 sq. in. (6.45 sq. cm).

TABLE XVIII BOND STRENGTH TENSILE TESTS - +70°F (21°C) (Continued)

Specimen No.	Gage Length, in. (cm)	Load Rate, in./min(cm/min)	Lap, in. (cm)	Width, in. (cm)	Load, lbs (Kg)	Film Stress, Ksi (Kg/Sq. cm)	Lap Stress, Psi (Kg/Sq. cm)	Failure Location
.25 mil (.00635 mm) Kapton sputtered with 5000 Å Gold on one side and diffusion bonded. Total Film Thickness = .50 mil (.0127 mm)								
B1/4KSB5KAAu-1	5.5 (13.97)	1.0 (2.54)	1/2* (1.27)*	1.0 (2.54)	15.75 (7.15)	31.5 (2214.7)	15.75 (1.11)	Adjacent
-2	→	→	→	→	12.50 (5.67)	25.0 (1757.7)	12.50 (.88)	Adjacent
-3	→	→	→	→	11.50 (5.22)	23.0 (1617.1)	11.50 (.81)	Film
-4	→	→	→	→	10.75 (4.88)	21.5 (1511.6)	10.75 (.76)	Grip
-5	→	→	→	→	12.75 (5.78)	25.5 (1792.8)	12.75 (.90)	Grip
LAP JOINT								
L1/4KSB5KAAu-1	5.5 (13.97)	1.0 (2.54)	1/2 (1.27)	1.0 (2.54)	12.75 (5.78)	25.5 (1792.8)	25.5 (1.79)	Film
-2	→	→	→	→	10.00 (4.53)	20.0 (1406.1)	20.0 (1.41)	Film
-3	→	→	→	→	11.25 (5.10)	22.5 (1581.9)	22.5 (1.58)	Film
-4	→	→	→	→	14.00 (6.35)	28.0 (1968.6)	28.0 (1.97)	Film
-5	→	→	→	→	12.75 (5.78)	25.5 (1792.8)	25.5 (1.79)	Film
BUTT JOINT								
.25 mil (.00635 mm) Kapton sputtered with 10,000 Å Gold on one side and diffusion bonded. Total Film Thickness = .50 mil (.0127 mm)								
B1/4KSB10KAAu-1	5.5 (13.97)	1.0 (2.54)	1/2* (1.27)*	1.0 (2.54)	16.50 (7.48)	33.0 (2320.1)	16.50 (1.16)	Film
-2	→	→	→	→	18.00 (8.16)	36.0 (2531.0)	18.00 (1.27)	Adjacent
-3	→	→	→	→	13.15 (5.96)	26.3 (1849.8)	13.15 (.92)	Film
-4	→	→	→	→	14.25 (6.46)	28.5 (2003.7)	14.25 (1.00)	Film
-5	→	→	→	→	16.00 (7.26)	32.0 (2249.8)	16.00 (1.12)	Film
LAP JOINT								
L1/4KSB10KAAu-1	5.5 (13.97)	1.0 (2.54)	1/2 (1.27)	1.0 (2.54)	16.50 (7.48)	33.0 (2320.1)	33.0 (2.32)	Adjacent
-2	→	→	→	→	15.35 (6.96)	30.7 (2158.4)	30.7 (2.16)	Film
-3	→	→	→	→	14.25 (6.46)	28.5 (2003.7)	28.5 (2.00)	Film
-4	→	→	→	→	12.75 (5.78)	25.5 (1792.8)	25.5 (1.79)	Joint
-5	→	→	→	→	15.00 (6.80)	30.0 (2109.2)	30.0 (2.11)	Film

*Each side overall total lap area = 1 sq. in. (6.45 sq. cm).

3.3 Advanced Coating Evaluation

The purpose of Task III, Advanced Coating Evaluation, was to select the three most promising metallizing concepts from Task II for more complete evaluation at cryogenic temperatures. Within this phase of the program, film permeability, flexibility, bond strength and interply inflation characteristics were assessed over a temperature range of +25° to -252°C.

3.3.1 Material Selection

Based on the results obtained in Task II (Section 3.2) the following three materials were chosen for more extensive evaluation.

1. 1/4 mil Kapton film, sputter coated with 3000A° gold and laminated (Diffusion bonded)
2. 1/4 mil Kapton film, sputter coated with 5000A° gold and laminated (Diffusion bonded)
3. 1/2 mil Kapton film, sputter coated with 3000A° gold and laminated (Diffusion bonded)

Vacuum deposited coatings were eliminated from the selection since they were not as effective in reducing permeability as sputter-coated films. Vacuum-deposited gold on Kapton diffusion bonded laminates had a helium permeability rate in the order of 10^{-11} cc-mm/cm²-sec-cm Hg which is the same level obtained by sputter coating one side of Kapton film. Consequently, there was little advantage to diffusion bonding two films when the same results can be obtained by merely applying a sputtered coating rather than a vacuum deposited coating.

Mylar film, either plain or metallized, was not as impermeable to helium as were the Kapton films of comparable thicknesses and were therefore deleted from the selection. Also, Mylar film is not amenable to the diffusion bonding process; a process which appears to be the most effective method of reducing permeability.

The 3000^oÅ coatings were evaluated in an attempt to increase film flexibility without sacrificing impermeability since it was determined in Task II that the thickness of the metallized coating had little effect on permeability. The selection was also made to aid in establishing the minimum thickness of gold that could be applied and still effectively reduce gaseous permeability. The 5000^oÅ material was selected to obtain data at cryogenic temperatures on the thicker coating.

3.3.2 Permeability Measurements

Permeability samples were prepared from each material and tested per the procedures stated in Section 3.1.1. Helium permeability rate determinations were made at +25°C, -195°C and -252°C and liquid hydrogen permeability rates were measured at -252°C. Four replicate samples were run for each data point. The results of the permeability testing for Task III are presented in Table XIX .

All three film materials in Task III had approximately the same order of magnitude of permeability but the 3000^oÅ gold on Kapton (laminated) appears to be slightly more permeable than the 5000^oÅ gold on Kapton (laminated) indicating that 5000^oÅ (10,000^oÅ when laminated) is about the minimum thickness of metallization that can be applied without affecting the gas transmission rate through the film.

The 1/4 mil Kapton with 5000^oÅ gold samples in this task of the program had a higher permeability to helium gas than did the comparable film in Task II (nominally 10^{-11} vs 10^{-13} cc-mm/cm² - sec - cm Hg). Examining the sputtered surfaces revealed that the quality of the metallization in this Task was not as good as that obtained in Task II, primarily because the sputtering energy was lowered slightly in Task III to minimize film heating. In reducing the sputter - energy the density of the coating was lowered. In Task II it was evident that sputtering damaged the Kapton film slightly due to localized heating. Therefore, this attempt was made to reduce this degradation and increase the flexibility of the film at cryogenic temperatures with little or no sacrifice in permeability. The result was, however, that the permeability dropped to the level obtained with a vacuum metallized coating. The flexibility was increased (see Paragraph 3.3.3).

TABLE XIX SPECIFIC PERMEABILITY RATES OF DIFFUSION BONDED KAPTON FILM LAMINATES

Concept	Film Stress		Film Thickness Mils (mm)	Permeating Gas	Test Temperature °F (°C)	Gold Coating Thickness Å	Total Laminate Thickness Mils (mm)	Leak Rate cc/sec	Specific Permeability 10^{-11} cc-mm/cm ² sec.cm Hg	
	0%	20%								
Laminated film (Diffusion Bonded)	x		.25 (.00635)	Helium	+70 (21)	3000	.5 (.0127)	6.85×10^{-6}	6.78	
	x							15.60×10^{-6}	15.44	
	x							6.16×10^{-6}	6.10	
	x							4.73×10^{-6}	4.68	
	x							12.20×10^{-6}	12.08	
		x						29.60×10^{-6}	29.3	
		x						4.23×10^{-6}	4.19	
		x						15.70×10^{-6}	15.54	
		x						1.21×10^{-6}	1.19	
		x		.25 (.00635)	Helium	-320 (+95)	3000	.5 (.0127)	11.90×10^{-6}	11.78
		x							13.30×10^{-6}	13.17
		x							6.11×10^{-6}	6.05
		x							5.38×10^{-6}	5.33
		x							11.70×10^{-6}	11.58
		x							11.80×10^{-6}	11.68
		x							1.74×10^{-6}	1.72
		x							12.90×10^{-6}	12.77
		x		.25 (.00635)	Helium	-423 (-252)	3000	.5 (.0127)	1.84×10^{-6}	1.80
		x							1.88×10^{-6}	1.86
		x							12.30×10^{-6}	12.12
	x							8.03×10^{-6}	7.95	
	x							5.20×10^{-6}	5.15	
	x							11.50×10^{-6}	11.38	
		x						5.12×10^{-6}	5.07	
		x						2.10×10^{-6}	2.07	
		x						11.1×10^{-6}	10.98	
		x	.25 (.00635)	Hydrogen	-423 (-252)	3000	.5 (.0127)	3.50×10^{-6}	3.46	
		x						1.50×10^{-4}	148	
		x						5.2×10^{-4}	515	
		x						6.1×10^{-4}	604	
		x						5.2×10^{-4}	515	
								1.8×10^{-4}	178	
		x						22.0×10^{-4}	2178	
		x						0.41×10^{-4}	40	
		x	.25 (.00635)		-423 (-252)		.5 (.0127)	0.17×10^{-4}	16	

TABLE XIX SPECIFIC PERMEABILITY RATES OF DIFFUSION BONDED KAPTON FILM LAMINATES (Continued)

Concept	Film Stress		Film Thickness Mils (mm)	Permeating Gas	Test Temperature °F (°C)	Gold Coating Thickness Å	Total Laminate Thickness Mils (mm)	Leak Rate cc/sec	Specific Permeability 10^{-11} cc-mm/cm ² sec:cm Hg	
	0%	20%								
Laminated Film (Diffusion Bonded)	x		.25 (.00635)	Helium	+70 (+21)	5000	.5 (.0127)	10.70×10^{-6}	10.59	
	x							12.60×10^{-6}	12.47	
	x							7.33×10^{-6}	7.26	
	x							13.50×10^{-6}	13.37	
		x						4.19×10^{-5}	41.5	
		x						1.08×10^{-5}	10.7	
		x						9.35×10^{-5}	92.6	
		x						1.47×10^{-5}	14.5	
		x		.25 (.00635)	Helium	-320 (-195)	5000	.5 (.0127)	10.90×10^{-6}	10.79
		x							11.70×10^{-6}	11.58
		x							2.42×10^{-6}	2.39
		x							7.86×10^{-6}	7.78
		x							13.40×10^{-6}	13.27
		x							6.78×10^{-6}	6.71
		x							2.65×10^{-6}	2.62
		x							3.11×10^{-6}	3.07
		x		.25 (.00635)	Helium	-423 (-252)	5000	.5 (.0127)	8.91×10^{-6}	8.82
	x							9.73×10^{-6}	9.63	
	x							2.27×10^{-6}	2.24	
	x							8.07×10^{-6}	7.98	
		x						14.00×10^{-6}	13.86	
		x						0.64×10^{-6}	0.63	
		x						16.10×10^{-6}	15.94	
		x						3.38×10^{-6}	3.35	
	x		.25 (.00635)	Hydrogen	-423 (-252)	5000	.5 (.0127)	2.9×10^{-5}	28.7	
	x							11.0×10^{-5}	108.9	
	x							16.0×10^{-5}	158.4	
	x							11.0×10^{-5}	108.9	
		x						3.5×10^{-4}	346	
		x						4.3×10^{-4}	425	
		x						3.0×10^{-4}	297	
		x	.25 (.00635)		-423 (-252)		.5 (.0127)	0.18×10^{-4}	17	

TABLE XIX SPECIFIC PERMEABILITY RATES OF DIFFUSION BONDED KAPTON FILM LAMINATES (Continued)

Concept	Film Stress		Film Thickness Mils (mm)	Permeating Gas	Test Temperature °F (°C)	Gold Coating Thickness Å	Total Laminate Thickness Mils (mm)	Leak Rate cc/sec	Specific Permeability 10^{-11} cc-mm/cm ² -sec-cm Hg
	0%	20%							
Laminated Film (Diffusion Bonded)	x		.5 (.0127)	Helium	+70 (+21)	3000	1.0 (.0254)	2.88 x 10 ⁻⁶	5.70
	x							8.84 x 10 ⁻⁶	17.50
	x							6.52 x 10 ⁻⁶	12.91
	x							2.92 x 10 ⁻⁶	5.78
		x		Helium	-320 (-195)	3000	1.0 (.0254)	9.75 x 10 ⁻⁶	19.31
		x						14.9 x 10 ⁻⁶	29.5
		x						15.30 x 10 ⁻⁶	30.29
		x						8.59 x 10 ⁻⁶	17.00
		x		Helium	-423 (-252)	3000	1.0 (.0254)	3.10 x 10 ⁻⁶	6.14
		x						7.77 x 10 ⁻⁶	15.38
		x						10.20 x 10 ⁻⁶	20.19
		x						3.37 x 10 ⁻⁶	6.67
		x	x	Helium	-423 (-252)	3000	1.0 (.0254)	10.20 x 10 ⁻⁶	20.19
		x	x					13.10 x 10 ⁻⁶	25.93
		x	x					14.40 x 10 ⁻⁶	28.51
		x	x					7.32 x 10 ⁻⁶	14.49
		x	x	Hydrogen	-423 (-252)	3000	1.0 (.0254)	1.24 x 10 ⁻⁶	2.46
		x	x					6.42 x 10 ⁻⁶	12.71
		x	x					10.70 x 10 ⁻⁶	21.18
		x	x					3.59 x 10 ⁻⁶	7.11
		x	Hydrogen	-423 (-252)	3000	1.0 (.0254)	10.10 x 10 ⁻⁶	19.99	
		x					7.07 x 10 ⁻⁶	13.99	
		x					11.80 x 10 ⁻⁶	23.36	
		x					12.20 x 10 ⁻⁶	24.15	
	x	x	Hydrogen	-423 (-252)	3000	1.0 (.0254)	1.30 x 10 ⁻⁵	25.7	
	x	x					0.96 x 10 ⁻⁵	19.00	
	x	x					4.7 x 10 ⁻⁵	93	
	x	x					1.40 x 10 ⁻⁵	27.7	
		x	Hydrogen	-423 (-252)	3000	1.0 (.0254)	1.80 x 10 ⁻⁵	35.6	
		x					2.20 x 10 ⁻⁵	43.5	
		x					1.50 x 10 ⁻⁵	29.7	
		x					2.8 x 10 ⁻⁵	55.4	

3.3.3 Film Flexibility

Twist-flex samples of each laminate material were tested at -252°C to determine their relative flexibilities (see paragraph 3.1.2 for procedures utilized), and the results are tabulated in Table XX . Comparing these results with those shown in Table XVII for Task II, reveals that the twist-flex life of the metallized film laminates, especially the 1/2 mil samples, improved. This increase is attributed to the lower sputtering energy utilized resulting in less film degradation.

3.3.4 Bond Strength Determinations

Tables XXI and XXII present the results of the butt- and lap-bond tests at -195°C and -252°C . As demonstrated throughout the program a very reliable joint can be made with the diffusion bonded laminates. The failures in this task were mostly in the film itself at stress levels comparable to that obtained with the plain Kapton film.

Configurations of the lap and butt joints are presented in Figure 18 .

3.3.5 Interply Inflation

Interply inflation specimens (see paragraph 3.1.4) were prepared and tested at -195°C and -252°C . No inflation was noted at either temperature for immersion times of 5 and 30 minutes.

TABLE XX - TWIST-FLEX TEST RESULTS @ -423°F (-252°C)

Material	Specimen No.	Total Film Thickness Mils (mm)	Cycles	Results	Leak Rate After Test cc/sec
Laminated .25 mil (.00635 mm) Kapton, 3000 A gold	1	.50 (.0127) ↓	25	Intact	0.46
	2		50	Torn	—
	3		35	Torn	17.5
	4		40	Torn	—
	5		30	Intact	1.9
Laminated .25 mil (.00635 mm) Kapton, 5000 A gold	1	.50 (.0127) ↓	35	Intact	3×10^{-2}
	2		55	"	6×10^{-4}
	3		75	"	1.7×10^{-2}
	4		150	Torn	—
	5		120	Torn	—
	6		107	Intact	0
	7		95	Intact	5×10^{-3}
Laminated .5 mil (.0127 mm) Kapton, 3000 A gold	1	1.0 (.0254) ↓	50	Torn	—
	2		25	Torn	—
	3		15	Intact	0
	4		20	Torn	—
	5		20	Intact	0

TABLE XXI - BOND STRENGTH RESULTS AT -423°F (-252°C)—BUTT JOINT

Material	Specimen No.	Joint		Load Lbs (Kg)	Film Stress Ksi (Kg/Sq. cm)	Joint Stress Psi (Kg/Sq. cm)	Failure Location
		Area Sq. In. (Sq. cm)	Width In. (cm)				
Laminated .25 mil (.00635 mm) Kapton, 3000 Å gold	1	1.00 (6.45)	1.00 (2.54)	25.5 (11.57)	51.0 (3585.3)	25.5 (1.77)	Film
	2	↓	↓	12.2 (5.53)	24.4 (1715.3)	12.2 (0.86)	Grip
	3	↓	↓	23.5 (10.66)	47.0 (3304.1)	23.5 (1.65)	Film
	4	↓	↓	21.8 (9.89)	43.6 (3065.1)	21.8 (1.53)	Film
	5	↓	↓	25.7 (11.66)	51.4 (3613.4)	25.7 (1.81)	Film
Laminated .25 mil (.00635 mm) Kapton, 5000 Å gold	1	1.00 (6.45)	1.00 (2.54)	21.25 (9.64)	42.5 (2987.7)	21.25 (1.49)	Film
	2	↓	↓	27.0 (12.25)	54.0 (3796.2)	27.0 (1.90)	Film
	3	↓	↓	24.0 (10.88)	48.0 (3374.4)	24.0 (1.69)	Film
	4	↓	↓	14.2 (6.44)	28.4 (1996.5)	14.2 (1.00)	Grip
	5	↓	↓	25.0 (11.34)	50.0 (3515.0)	25.0 (1.76)	Film
Laminated .5 mil (.0127 mm) Kapton, 3000 Å gold	1	1.00 (6.45)	1.00 (2.54)	31.1 (14.15)	31.1 (2186.3)	31.1 (2.18)	Film
	2	↓	↓	33.3 (15.10)	33.3 (2341.2)	33.3 (2.34)	Film
	3	↓	↓	32.8 (14.87)	32.8 (2306.0)	32.8 (2.31)	Film
	4	↓	↓	33.0 (14.97)	33.0 (2320.1)	33.0 (2.32)	Film
	5	↓	↓	31.8 (14.42)	31.8 (2235.8)	31.8 (2.24)	Film

TABLE XXII- BOND STRENGTH RESULTS AT -423°F (-252°C)—LAP JOINT

Material	Specimen No.	Joint		Load Lbs. (Kg)	Film Stress Ksi (Kg/Sq. cm)	Joint Stress Psi (Kg/Sq. cm)	Failure Location
		Area Sq. In. (Sq. cm)	Width In. (cm)				
Laminated .25 mil (.00635 mm) Kapton, 3000 Å gold	1	.5 (3.22)	1.00 (6.45)	16.6 (7.53)	33.2 (2334.2)	33.2 (15.06)	Film
	2			16.5 (7.48)	33.0 (2320.1)	33.0 (14.97)	"
	3			16.6 (7.53)	33.2 (2334.2)	33.2 (15.06)	"
	4			15.2 (6.89)	30.4 (2123.3)	30.4 (13.78)	"
	5			11.1 (5.03)	22.2 (1560.8)	22.2 (10.07)	Grip
Laminated .25 mil (.00635 mm) Kapton, 5000 Å gold	1	.5 (3.22)	1.00 (6.45)	19.5 (8.85)	39.0 (2742.0)	39.0 (17.69)	Film
	2			16.4 (7.44)	32.8 (2249.8)	32.8 (14.87)	"
	3			20.5 (9.30)	41.0 (2882.6)	41.0 (18.60)	"
	4			0.22 (1.00)	0.44 (30.9)	0.44 (0.20)	Grip
	5			23.0 (10.43)	46.0 (3234.1)	46.0 (20.86)	Film
Laminated .5 mil (.0127 mm) Kapton, 3000 Å gold	1	.5 (3.22)	1.00 (6.45)	20.8 (9.43)	20.8 (1462.7)	41.6 (18.87)	Film
	2			20.7 (9.38)	20.7 (1455.4)	41.4 (18.78)	"
	3			19.4 (8.79)	19.4 (1363.9)	38.8 (17.60)	"
	4			19.7 (8.94)	19.7 (1385.0)	39.4 (17.87)	"
	5			18.0 (8.16)	18.0 (1265.5)	36.0 (16.33)	"

4.0 CONCLUSIONS

- a. The objective of this program, to establish the feasibility of reducing the gas permeability of polymeric films, was accomplished. It was demonstrated that the diffusion-bonded laminate concept is capable of reducing the helium or liquid hydrogen permeability of Kapton and Mylar films by 3 to 4 orders of magnitude without drastically altering their flexibility at cryogenic temperatures. Permeability rates as low as 1×10^{-15} cc-mm/cm²-sec-cm Hg were obtained. The degree of impermeability obtained with this concept appears more dependent upon the quality of the applied coating than on its thickness. If the porosity of the applied coating is too high, the diffusion bonding process can not statistically seal a significant portion of the holes and a high permeability rate persists.
- b. The diffusion bonded laminate concept is suitable for bladder or component fabrication since it was demonstrated that strong reliable joints can be made without affecting the integrity of the film laminate. The joints made with the diffusion bonded laminates were as strong as those made with the plain Kapton film and the type of failure similar.
- c. Metallizing Mylar or Kapton by either vacuum deposition or sputtering reduces the film's cryogenic flexibility slightly. There was no evidence however, that the diffusion bonding process itself resulted in further reductions in film flexibility. However, considering the reduction in flexibility due to metallization, the twist-flex life of a Kapton laminate was still equal to that of plain Mylar of equal thickness.
- d. The laminate concept is applicable as a barrier ply for polymeric expulsion devices, cryogenic insulation systems, and as a space-stable bagging material where the combination of low permeability and flexibility is important over a wide temperature range.

5.0 REFERENCES

1. Contract NAS 3-7952, "Polymeric Expulsion Bladders for Liquid Oxygen Systems" NASA CR-72418, J. T. Hoggatt, June 1968.
2. Contract NAS 3-11192, "Liquid Hydrogen Positive Expulsion Bladders", NASA CR-72432, K. E. Wiedekamp, May 1968.
3. Contract NAS 3-6288, "Development of Cryogenic Positive Expulsion Bladders", NASA CR-72115, D. H. Pope and J. E. Penner, January 1968
4. Unpublished Boeing Data, J. T. Hoggatt, 1969.
5. Contract NAS3-7944 "Liners For Non-Metallic Tanks", NASA CR-SY868, J. T. Hoggatt and L. J. Workman, Jan. 1966.
6. R. P. Caren, et.al. "Low-Temperature Tensile, Thermal Contraction, and Gaseous Hydrogen Permeability Data on Hydrogen-Vapor Barrier Materials" Advances in Cryogenic Engineering, Plenum Press, New Yor, p. 171, Vol.10, 1964.
7. R. F. Lark, "Cryogenic Positive Expulsion Bladders" Journal Macromole-
cular Sci-Phys., BI(4), 623-637, December 1967.

FINAL REPORT DISTRIBUTION LIST FOR
NASA CR-120892
"Investigation of the Feasibility of Developing Low-
Permeability Polymeric Films"
NAS3 - 13326

	<u>Copies</u>		<u>Copies</u>
Natl. Aeronautics & Space Admin. Lewis Research Center 21000 Brookpark Road Cleveland, OH 44135		Natl. Aeronautics & Space Admin. George C. Marshall Space Flight Ctr. Huntsville, AL 35812	1
Attn: Contracting Officer, MS500-313	1	Attn: Library	1
Tech. Rpt. Control Off. MS5-5	1	K. Chandler	1
Tech. Utilization Off., MS3-16	1	James M. Stuckey, S&E-ASTN-MNM	1
AFSC Liaison Off., MS4-1	1		
Library, MS60-3	2	Natl. Aeronautics & Space Admin. Manned Spacecraft Center Houston, Texas 77001	
Off. Reliability & Quality Assurance, MS 500-111	1	Attn: Library	1
R. H. Kemp, MS 49-1	1	L. J. Leger, ES-5	1
T. T. Serafini, MS 49-1	1	R. E. Johnson, SMD-Materials Tech.	1
R. F. Lark, Project Manager MS 49-1	10		
T. J. Riley, MS 54-5	1	Natl. Aeronautics & Space Admin. Office of Tech. Utilization Washington, D. C. 20546	1
L. H. Thaller, MS 309-1	1		
J. Freche, MS 49-1	1	Natl. Aeronautics & Space Admin. Ames Research Center Moffett Field, CA 94035	
R. Hall, MS 105-1	1	Attn: Library	1
G. M. Ault, MS 3-13	1	Dr. J. Parker	1
R. H. Knoll, MS 501-2	1		
J. R. Barber, MS 500-209	1	Natl. Aeronautics & Space Admin. Flight Research Center P. O. Box 273 Edwards, CA 93523	
D. L. Nored, MS 500-209	1	Attn: Library	1
Natl. Aeronautics & Space Admin. Office of Advanced Res. & Tech. Washington, D. C. 20546			
Attn: G. C. Deutsch, Director Materials & Structures Div., Code RW	1	Natl. Aeronautics & Space Admin. Goddard Space Flight Center Greenbelt, MD 20771	
J. J. Gangler, Code RW	1	Attn: Library	1
B. Achhammer, Code RW	1		
A. O. Tischler, Director, Shuttle Technology Office	1	Natl. Aeronautics & Space Admin. Goddard Space Flight Center Greenbelt, MD 20771	
D. Ginter, Director, Technology Applications Office	1	Attn: Library	1
W. Woodward, Director Propulsion & Power Division	1		
Natl. Aeronautics & Space Admin. Langley Research Center Hampton, VA 23365		NASA Scientific & Tech. Infor. Facility, Box 33 College Park, MD 20740	
Attn: Library	1	Attn: NASA Representative	2
E. E. Mathauser, MS 188A	1		

	<u>Copies</u>		<u>Copies</u>
Natl. Tech. Information Service Springfield, VA 22151	6	U. S. Air Force Washington, D. C. Attn: Library	1
Jet Propulsion Laboratory 4800 Oak Grove Drive Pasadena, CA 91103 Attn: Library Warren Jensen		Col. C. K. Stambaugh, Code AFRST	1
Air Force Materials Laboratory Wright-Patterson Air Force Base, OH 45433 Attn: Library	1	Defense Metals Information Center	
H. S. Schwartz, (LN)	1	Battelle Memorial Institute Columbus Laboratories 505 King Ave. Columbus, OH 43201	1
R. T. Schwartz, (LN)	1		
Dr. W. L. Lehn	1	Defense Documentation Center	
G. P. Peterson (LC)	1	Cameron Station, Bldg. 5 5010 Duke St. Alexandria, VA 22314	
J. K. Sieron	1	Attn: TISIA	1
S. Litvak (LTF)	1	Office of the Director of Defense Research & Engineering Wash., DC 20301	
T. Reinhart (LAE)	1	Attn: Office of Asst. Dir. (Chem. Technology)	1
Air Force Flight Dynamics Lab. Wright-Patterson Air Force, Base OH 45433 Attn: Library	1	Arnold Engineering Development Center	
R. Quigley	1	Air Force Systems Command Tullahoma, Tenn. 37389	
Air Force Office of Scientific Research 1400 Wilson Boulevard Arlington, VA 22209 Attn: SIGL		Attn: Library AEOIM	1
Air Force Rocket Propulsion Lab. Edwards, CA 93523 Attn: J. Branigan	1	U. S. Army Missile Command Redstone Scientific Information Center Redstone Arsenal, AL 35808	
Air Force Office of Scientific Research Washington, DC 20333 Attn: SREP, Dr. J. F. Masi	1	Attn: Document Section	1
Space and Missile Systems Organization Air Force Unit Post Office Los Angeles, CA 90045 Attn: Technical Data Center		Advanced Research Projects Agency Washington, DC 20525 Attn: Library	1
	1	Department of The Army U. S. Army Material Command Washington, DC 20315	
		Attn: AMCRD-RC	1
	1	Department of The Army U. S. Army Aviation Matl. Lab. Fort Eustis, VA 23604	
		Attn: A. J. Gustafson R. Berrisford	1
			1

	<u>Copies</u>		<u>Copies</u>
Department of The Army U. S. Army Aviation Systems Command P. O. Box 209 St. Louis, MO 63166 Attn: R. Vollmer, AMSAV-A-UE	1	Commander Naval Ordnance Systems Command U. S. Navy Department Washington, DC 20360 Attn: ORD-033 (B. Drimmer) ORD-0333A (M. Kinna)	1 1
Department of The Army Watertown Arsenal Watertown, MA 02172 Attn: A. Thomas	1	Director Deep Submergence Systems Project 6900 Wisconsin Ave. Washington, DC 20015 Attn: DSSP-221 (H. Bernstein)	1
Department of The Army Watervliet Arsenal Watervliet, NY 12189 Attn: F. W. Schmiedershoff	1	Director Naval Research Laboratory Washington, DC 20390 Attn: Code 8430 Dr. I. Wolock, Code 8433	1 1
Department of The Army Picatinny Arsenal Dover, NJ 07801 Attn: H. E. Pebly, Jr. I. Forsten	1	Department of the Navy Office of Naval Research Washington, DC 20360 Attn: J. H. Shenk	1 1
Commander Natick Laboratories U. S. Army Natick, MA 01762 Attn: T. Ciavarini	1	Strategic Systems Projects Office Department of the Navy Washington, DC 20360 Attn: Director	1
U. S. Army Missile Command Redstone Arsenal Redstone Arsenal, AL 35809 Attn: W. S. Crownover, AMSMI-RKP	1	Commander U. S. Naval Missile Center Point Mugu, CA 93041 Attn: Technical Library	1
U. S. Army Materials & Mechanics Res. Center Watertown Arsenal Watertown, MA 02192 Attn: S. Arnold	1	Commander U. S. Naval Weapons Center China Lake, CA 93557 Attn: Library	1
Commander Naval Air-Systems Command U. S. Navy Department Washington, DC 20360 Attn: AIR-5203 (P. Goodwin) AIR-52032A (C. Bersch) AIR-52032D (M. Stander)	1 1 1	Department of The Navy Naval Ordnance Laboratory White Oak, Silver Spring, MD 20910 Attn: F. R. Barnet R. Simon	1 1

	<u>Copies</u>		<u>Copies</u>
Department of The Navy U. S. Naval Ship R&D Laboratory, Annapolis Annapolis, MD 21402 Attn: C. Hershner, Code 2724	1	Esso Research & Engineering Co. P. O. Box 45 Linden, NJ 07036 Attn: D. J. Angier	1
AVCO Corporation Applied Technology Division Lowell Industrial Park Lowell, MA 01851 Attn: Mr. Allan S. Bufferd	1	Fairchild Hiller Corporation Republic Aviation Division Farmingdale, NY 11735 Attn: Library	1
Aeronutronic Division of Philco Ford Corporation Ford Road Newport Beach, CA 92663 Attn: Technical Information Dept.	1	The Fiberite Corporation 512 W. Fourth Street Winona, MN 55987 Attn: S. P. Prosen	1
Battelle Memorial Institute Columbus Laboratories 505 King Ave. Columbus, OH 43201 Attn: F. Jelinek	1	FMC Corporation Chemical Research & Development Ctr. P. O. Box 8 Princeton, NJ 08540 Attn: Security Officer	1
Beech Aircraft Corporation Boulder Facility P. O. Box 631 Boulder, Colo. Attn: D. Pope	1	General Dynamics/Convair P. O. Box 1128 San Diego, CA 92112 Attn: J. L. Christian	1
Brunswick Corporation Defense Products Division P. O. Box 4594 43000 Industrial Avenue Lincoln, NB Attn: J. Carter	1	General Electric Company Flight Propulsion Lab. Dept. Cincinnati, OH 45201 Attn: Library	1
The Boeing Company Vertrol Division Morton, PA 19070 Attn: Library	1	General Electric Company Valley Forge Space Technology Ctr. P. O. Box 8555 Philadelphia, PA 19101 Attn: Library	1
Chemical Propulsion Information Agency Applied Physics Laboratory 8621 Georgia Ave. Silver Spring, MD 20910 Attn: Library T. Reedy	1	Grumman Aerospace Corporation Bethpage, Long Island, NY 11714 Attn: Library	1
	1	Goodyear Aerospace Corporation 1210 Massillon Road Akron, OH 44315 Attn: L. W. Toth	1
	1	General Dynamics P. O. Box 748 Fort Worth, TX 76100 Attn: Library	1

Copies

G. T. Schjeldahl Co.
Northfield, Minn.
Attn: Library 1

United Aircraft Corporation
400 Main Street
East Hartford, CT 06108
Attn: Corporation Library 1

United Aircraft Corporation
Research Laboratories
East Hartford, CT 06108
Attn: K. Kreider 1

United Aircraft Corporation
United Technology Center Division
P. O. Box 358
Sunnyvale, CA 94088
Attn: Library 1

Whittaker Corporation
3640 Aero Court
San Diego, CA 92123
Attn: V. Chase 1