

REPORT NO. NADC-77149-30

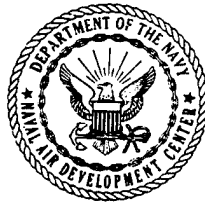

DESIGN AND TEST OF A LOW COST, SURVIVABLE COMPOSITE FUSELAGE

T.E. Hess, R.J. Richey, Jr., and S.L. Huang
Air Vehicle Technology Department
NAVAL AIR DEVELOPMENT CENTER
Warminster, Pennsylvania 18974

1 AUGUST 1977

FINAL REPORT
IED TASK NO. ZF61412001
Work Unit No. GC-313

*Checked
DPS no Acc. #*

APPROVED FOR PUBLIC RELEASE; DISTRIBUTION UNLIMITED

19960223 054

Prepared for
NAVAL AIR SYSTEMS COMMAND
Department of the Navy
Washington, D.C. 20361

DTIC QUALITY INSPECTED-1

PLASTEG 29421

NOTICES

REPORT NUMBERING SYSTEM - The numbering of technical project reports issued by the Naval Air Development Center is arranged for specific identification purposes. Each number consists of the Center acronym, the calendar year in which the number was assigned, the sequence number of the report within the specific calendar year, and the official 2-digit correspondence code of the Command Office or the Functional Department responsible for the report. For example: Report No. NADC-76015-40 indicates the fifteenth Center report for the year 1976, and prepared by the Crew Systems Department. The numerical codes are as follows:

CODE	OFFICE OR DEPARTMENT
00	Commander, Naval Air Development Center
01	Technical Director, Naval Air Development Center
02	Program and Financial Management Department
07	V/STOL Program Office
09	Technology Management Office
10	Naval Air Facility, Warminster
20	Aero Electronic Technology Department
30	Air Vehicle Technology Department
40	Crew Systems Department
50	Systems Department
60	Naval Navigation Laboratory
81	Technical Support Department
85	Computer Department

PRODUCT ENDORSEMENT - The discussion or instructions concerning commercial products herein do not constitute an endorsement by the Government nor do they convey or imply the license or right to use such products.

APPROVED BY:



P. M. STURM
Commander, USN
Deputy Director, AVTD

DATE:

1 August 1977

UNCLASSIFIED

SECURITY CLASSIFICATION OF THIS PAGE (When Data Entered)

REPORT DOCUMENTATION PAGE		READ INSTRUCTIONS BEFORE COMPLETING FORM
1. REPORT NUMBER NADC-77149-30	2. GOVT ACCESSION NO.	3. RECIPIENT'S CATALOG NUMBER
4. TITLE (and Subtitle) DESIGN AND TEST OF A LOW COST, SURVIVABLE COMPOSITE FUSELAGE		5. TYPE OF REPORT & PERIOD COVERED FINAL REPORT
		6. PERFORMING ORG. REPORT NUMBER
7. AUTHOR(s) T. E. HESS, R. J. RICHEY, JR., S. L. HUANG		8. CONTRACT OR GRANT NUMBER(s)
9. PERFORMING ORGANIZATION NAME AND ADDRESS AIR VEHICLE TECHNOLOGY DEPARTMENT NAVAL AIR DEVELOPMENT CENTER 35 WARMINSTER, PA 18974		10. PROGRAM ELEMENT, PROJECT, TASK AREA & WORK UNIT NUMBERS IED TASK NUMBER ZF61412001 WORK UNIT GC-313
11. CONTROLLING OFFICE NAME AND ADDRESS DIRECTOR, NAVAL RESEARCH LABORATORY Department of the Navy WASHINGTON, D.C. 20375		12. REPORT DATE 1 AUGUST 1977
		13. NUMBER OF PAGES 160
14. MONITORING AGENCY NAME & ADDRESS (if different from Controlling Office)		15. SECURITY CLASS. (of this report) UNCLASSIFIED
		15a. DECLASSIFICATION/DOWNGRADING SCHEDULE
16. DISTRIBUTION STATEMENT (of this Report) APPROVED FOR PUBLIC RELEASE; DISTRIBUTION UNLIMITED		
17. DISTRIBUTION STATEMENT (of the abstract entered in Block 20, if different from Report)		
18. SUPPLEMENTARY NOTES Appendices A, B		
19. KEY WORDS (Continue on reverse side if necessary and identify by block number) aircraft structures Epoxy 8501 hybrid composite Graphite AS primary structure Epoxy SP250 crack arresters Fiberglass S damage tolerance Luminite II/4		
20. ABSTRACT (Continue on reverse side if necessary and identify by block number) A damage tolerant hybrid composite fuselage section has been designed, fabricated and tested. One of the key features of this structure is the integral crack arresters which have been incorporated into the design to increase its tolerance to damage, either inherent flaws or battle induced damage. The ability of the design to withstand critical flight loads has been demonstrated by both analysis and test. The effectiveness of the crack arresters, which are designed to stop a propagating crack (damage) and still allow the structure to carry limit load, was proven in a series of tests where the		

DD FORM 1 JAN 73 1473

EDITION OF 1 NOV 65 IS OBSOLETE
S/N 0102-LF-014-6601

UNCLASSIFIED

SECURITY CLASSIFICATION OF THIS PAGE (When Data Entered)

UNCLASSIFIED

SECURITY CLASSIFICATION OF THIS PAGE (When Data Entered)

initial damage was of two types, a preformed crack cut with a saw blade and that resulting from projectiles fired into the shell. The design has been completely analyzed using finite element techniques and shown to save both weight and cost over its metal counterpart. Analysis and testing of composite panels has also been done to investigate failure modes and establish design criteria for crack arrester designs.

UNCLASSIFIED

SECURITY CLASSIFICATION OF THIS PAGE (When Data Entered)

DISCLAIMER NOTICE



THIS DOCUMENT IS BEST QUALITY AVAILABLE. THE COPY FURNISHED TO DTIC CONTAINED A SIGNIFICANT NUMBER OF PAGES WHICH DO NOT REPRODUCE LEGIBLY.

S U M M A R Y

A damage tolerant hybrid composite fuselage section has been designed, fabricated and tested. One of the key features of this structure is the integral crack arresters which have been incorporated into the design to increase its tolerance to damage, either inherent flaws or battle induced damage. The ability of the design to withstand critical flight loads has been demonstrated by both analysis and test. The effectiveness of the crack arresters, which are designed to stop a propagating crack (damage) and still allow the structure to carry limit load, was proven in a series of tests where the initial damage was of two types, a preformed crack cut with a saw blade and that resulting from projectiles fired into the shell. The design has been completely analyzed using finite element techniques and shown to save both weight and cost over its metal counterpart. Analysis and testing of composite panels has also been done to investigate failure modes and establish design criteria for crack arrester designs.

T A B L E O F C O N T E N T S

	<u>Page No.</u>
SUMMARY	1
1.0 INTRODUCTION	8
2.0 DESIGN CONDITIONS	11
3.0 STRUCTURE/MATERIAL SELECTION	11
4.0 MATERIAL CHARACTERIZATION	14
4.1 INTRODUCTION	14
4.2 SPECIMEN CONFIGURATION	14
4.3 RESULTS	14
5.0 FUSELAGE DESIGN AND ANALYSIS	26
5.1 INTRODUCTION	26
5.2 DESIGN DESCRIPTION	26
5.3 MATERIAL PROPERTIES	32
5.4 NASTRAN MODEL	32
5.5 BUCKLING DESIGN	49
5.6 STRENGTH AND MARGINS OF SAFETY	59
6.0 ELEMENT TESTS	63
7.0 SUBCOMPONENT DESIGN AND TESTING	63
7.1 DESIGN	63
7.2 TEST CONDITIONS AND FIXTURES	63
7.3 INSTRUMENTATION.	71
7.4 HYBRID COMPOSITE TESTING	71
8.0 FUSELAGE TESTING	78
8.1 INSTRUMENTATION	78
8.2 TEST METHODS AND EQUIPMENT	78
8.3 TEST LOAD CONDITIONS AND LOADING SEQUENCE	89

T A B L E O F C O N T E N T S (Cont'd)

	<u>Page No.</u>
8.4 FUSELAGE TESTING RECOVERY LOADS	89
8.5 FUSELAGE FAILURE ANALYSIS AND REPAIRS	100
8.6 RECOVERY LOADS TEST II, (AFTER REPAIR)	107
8.7 5G MANEUVER LOADS TEST	107
8.8 DAMAGE PROOF TEST	107
9.0 CONCLUSIONS	112
REFERENCES	113
APPENDIX A - NASTRAN BULK DATA.	A-1
APPENDIX B - NASTRAN ELEMENT STRESSES	B-1

L I S T O F T A B L E S

<u>Table No.</u>	<u>Title</u>	<u>Page No.</u>
4-1	Hybrid Panel A (Inner Face, 50% Glass), Longitudinal Tension Tests	16
4-2	Hybrid Panel A (Inner Face, 50% Glass), Transverse Tension Tests	17
4-3	Hybrid Panel A (Inner Face, 50% Glass), Compression Tests	18
4-4	Hybrid Panel A (Inner Face, 50% Glass), Shear Tests . .	19
4-5	Hybrid Panel A (Inner Face, 50% Glass), Poisson's Ratio	20
4-6	Hybrid Panel B (Outer Face, 2/3 Glass), Longitudinal Tension Tests	21
4-7	Hybrid Panel B (Outer Face, 2/3 Glass), Transverse Tension Tests	22
4-8	Hybrid Panel B (Outer Face, 2/3 Glass), Compression Tests	23
4-9	Hybrid Panel B (Outer Face, 2/3 Glass), Interlaminar Shear Tests	24
4-10	Hybrid Panel B (Outer Face, 2/3 Glass), Poisson's Ratio	25
5-1	Hybrid Composite Sandwich Materials	30
5-2	Material Properties Used for Design	38
5-3	Hybrid Composite Plate Element Properties	46, 47
5-4	Summary of Maximum Stresses - Recovery	53
5-5	Summary of Sandwich Panel Buckling Capability	60
6-1	Results of Close-out Section Tests	66
7-1	Strain Gage Locations	73
8-1	Applied Loads - Recovery Condition	92
8-2	Applied Loads - 5g Maneuver Condition	93

L I S T O F F I G U R E S

<u>Figure No.</u>	<u>Title</u>	<u>Page No.</u>
1-1	BQM-34E Point Design	9
1-2	Center Fuselage - Metal Design	9
1-3	Low Cost, Survivable Composite Fuselage	10
2-1	Ultimate Recovery Loads on Fuselage Section	12
2-2	Ultimate 5g Maneuver Loads on Fuselage Half Section . . .	12
2-3	Fuselage Cross Section Forward of Station 233.5	13
4-1	Test Specimen Configurations	15
5-1	Fuselage Honeycomb Sandwich Design	27
5-2	Closeout Section Design	28
5-3	Hybrid Sandwich Layup	29
5-4	Comparison of Metal and Composite Center Fuselage Designs	31
5-5	Right Side Fuselage Panel Design Drawing	33
5-6	Left Side Fuselage Panel Design Drawing	34
5-7	Fuel Access Door Design Drawing	35
5-8	Left Side Access Door Design Drawing	36
5-8a	Substructure Attachment Drawing	37
5-9	Fuselage Center Section Skin Model	39
5-10	Bulkhead 233.5 Model	40
5-11	Bulkhead 241.8 Model	41
5-12	Bulkhead 274.1 Model	42
5-13	Roof Structure Model	43
5-14	Strongback Model	44
5-15	Overwing Fairing Formers Model	45

L I S T O F F I G U R E S (Cont'd)

<u>Figure No.</u>	<u>Title</u>	<u>Page No.</u>
5-16	Wing Model	48
5-17	Outer Face Stresses - Recovery Condition	50
5-18	Inner Face Stresses - Recovery Condition	51
5-19	Access Door Stresses - Recovery Condition	52
5-20	Strength of Composite Fuselage Panels - Basic Section .	61
5-21	Strength of Composite Fuselage Panels - Reinforced Section	62
6-1	Closeout Specimen Configuration	64
6-2	Closeout Specimen Test Setup	65
6-3	Failed Closeout Specimens	67
7-1	Cylinder Subcomponent	68
7-2	Subcomponent Design (Drawing)	69
7-3	Cylinder Test Fixtures.	70
7-4	Cylinder Strain Gage Locations	72
7-5	Deflection Gage Locations	74
7-6	Cylinder Subcomponent Compression Test Setup	75
7-7	Cylinder Subcomponent Tension Test Setup	76
7-8	Propagated 2.54 cm Sawcut Crack	77
7-9	Crack Propagation from .95 cm Projectile Damage	79
7-10	Crack Propagation from 2.54 cm Projectile Damage	80
7-11	Propagated 1.59 cm Sawcut Crack	81
7-12	Cylinder After Testing	82
7-13	Summary of Crack Arrestment Tests	83
7-14	Hybrid Cylinder Crack Propagation Comparison to Theory	84

LIST OF FIGURES (Cont'd)

<u>Figure No.</u>	<u>Title</u>	<u>Page No.</u>
8-1	Right Fuselage Panel Strain Gage Locations	85
8-2	Left Fuselage Panel Strain Gage Locations	86
8-3	Access Door Strain Gage Locations	87
8-4a	Aluminum Band Loading Station	88
8-4b	Aluminum Strap Loading Station	88
8-5	Recovery Load Test Setup	90
8-6	5g Maneuver Load Test Setup	91
8-7	Frame Loading Stations	94
8-8	Fuselage Shear Diagram - Simulated Recovery Loads . . .	95
8-9	Fuselage Shear Diagram - Simulated 5g Maneuver Loads .	96
8-10	Fuselage Moment Diagram - Simulated Recovery Loads . .	97
8-11	Fuselage Moment Diagram - Simulated 5g Maneuver Loads .	98
8-12	Simulated Recovery Loads	99
8-13	Simulated 5g Maneuver Loads	99
8-14	Gage 4 Strains on 1st Run to DLL	101
8-15	Gage 10 Strains on 1st Run to DLL	102
8-16	Crack in Left Fuselage Panel	103
8-17	Crack in Right Fuselage Panel	103
8-18	Photograph of Crack in Left Fuselage Panel	104
8-19	Photograph of Crack in Right Fuselage Panel	105
8-20	Fuselage Repair Configuration	106
8-21	Installed Patch on Left Fuselage Panel	108
8-22	Installed Patch on Right Fuselage Panel	109
8-23	Location of Repair on Right Fuselage Panel	110
8-24	Location of Repair on Left Fuselage Panel	110
8-25	Induced Damage in Right Fuselage Panel	111

1.0

I N T R O D U C T I O N

Existing composite technology, based upon conservative metal-replacement philosophy and applied to individual secondary and small primary structures, has demonstrated significant structural advantages and has matured sufficiently to support a broader/total system application. Maximum composite payoff is recognized to be attainable through reconfiguration in the initial conceptual design. In-depth investigations to fully explore the potential cost and performance advantages of composites must exploit the tailorability and improved formability of composites. Cost reduction, weight reduction, and high tolerance to damage require design of the structural material system concurrently with the internal structural arrangement. An RPV provides a low risk/moderate cost opportunity to seek maximum utilization of composites at each level of design and manufacture.

The objectives of this program, therefore, are to develop a composite fuselage design which is low in cost compared to conventional metal design, affords increased survivability with respect to inherent flaws and hostile action and the resulting damage, and at the same time has reduced weight. The center fuselage section of the BQM-34E Remote Piloted Vehicle, Figure 1-1, was selected as the demonstration vehicle for this design/development. Although the technology presented here is directly applicable to manned aircraft, the RPV affords a basis for comparison between an inproduction, operational, metal counterpart and the redesigned composite version, and it provides an opportunity for near-term flight demonstration in both the subsonic and supersonic regimes. This same vehicle has been used as a test bed for an all graphite epoxy wing which was designed and fabricated at the Naval Air Development Center and which is currently flying on operational vehicles as part of the Navy's service evaluation program. This center fuselage section provides a practical design model since it contains access doors, wing attachment points, external fuel tank attachment and the recovery parachute line attachment.

The center fuselage section of the BQM-34E is 1.04m (41 inches) long, from station 233.5 to 274.1 and .63m (25 inches) in diameter. The metal design is aluminum sheet with reinforcing frames, a shear web which distributes parachute loads, a keel which reacts bending and external fuel tank loads, and a strongback which reacts parachute loads, Figure 1-2.

The through-wing is attached to this section in the upper portion of the cross section and an overwing structure covers the wing and closes out the circular shape. A large access door is at the bottom and runs the entire length of the section.

The overall procedure and work flow followed in this program is shown in Figure 1-3. The loads and criteria used were those of the BQM-34E. Studies were made from which material and type of construction were selected. Preliminary design and subcomponent testing were based on material properties determined analytically from micromechanics analysis of the selected material. At the same time fabrication processes were established and material coupons were fabricated and tested to characterize the material. Detailed design of the fuselage and a cylindrical test specimen were based on material properties from this characterization.

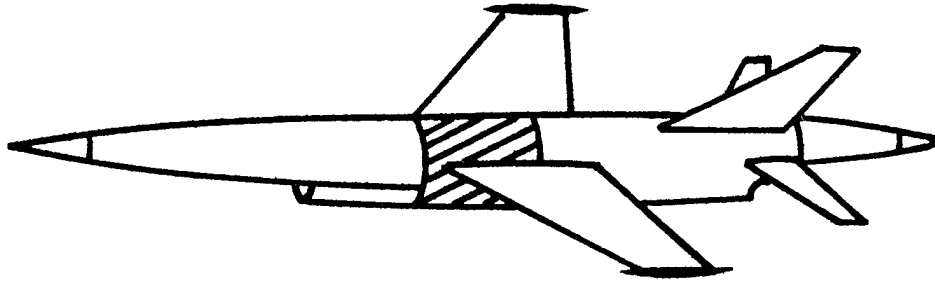

Figure 1-1. BQM-34E Point Design

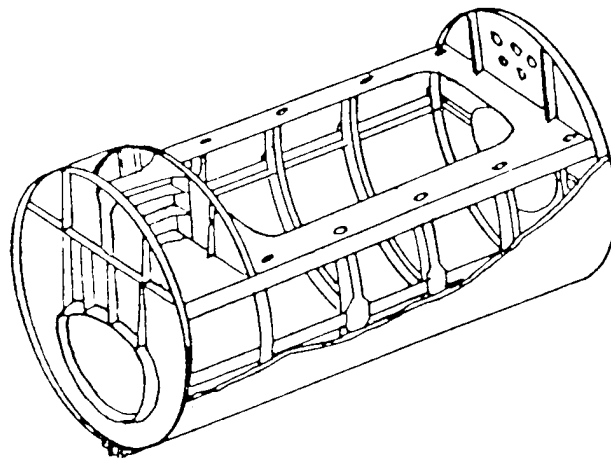

Figure 1-2. Center Fuselage - Metal Design

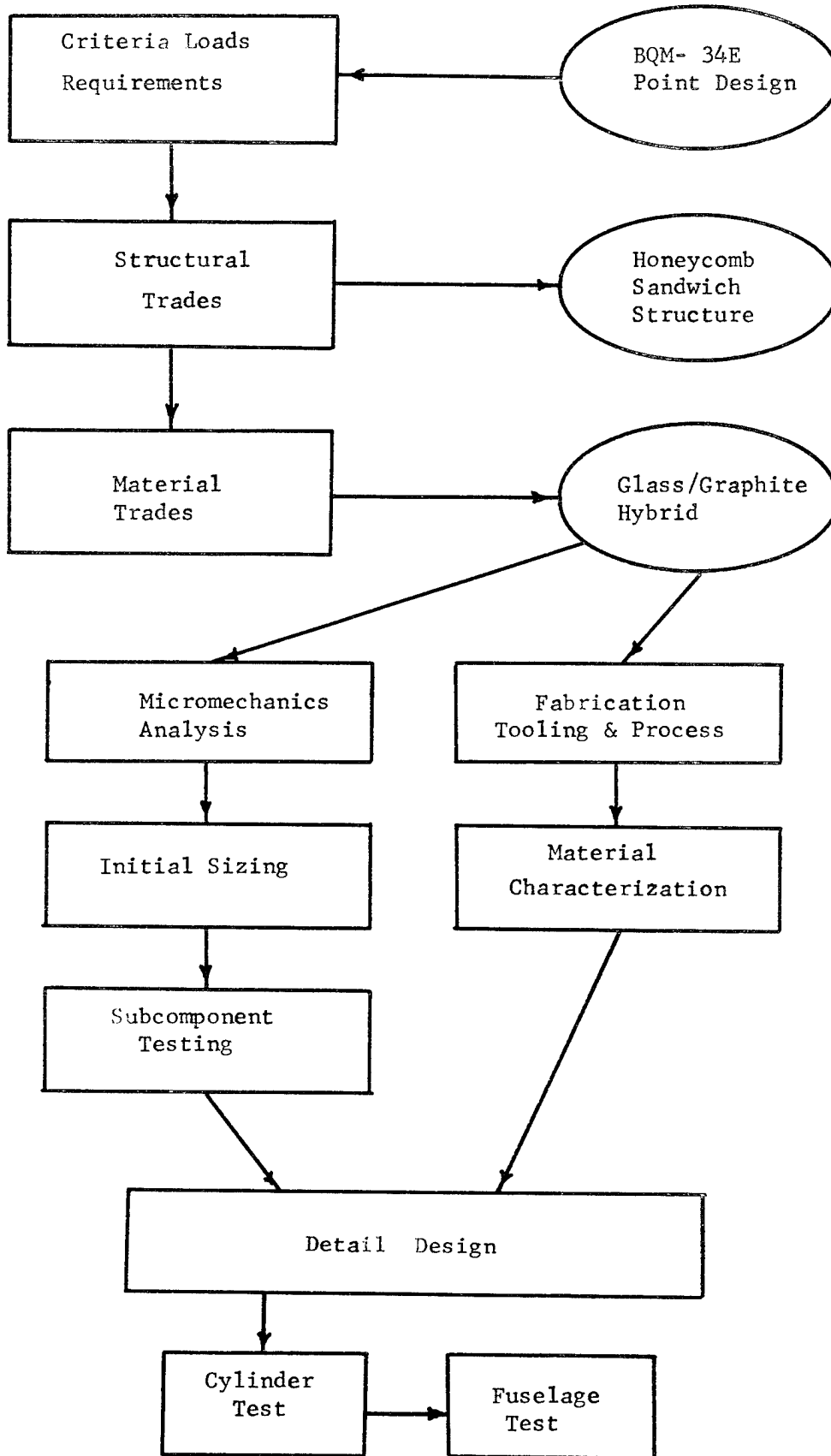

Figure 1-3. Low Cost, Survivable Composite Fuselage

2.0

DESIGN CONDITIONS

In designing the composite fuselage section, two design conditions were considered, based on a review of the metal design. These conditions are identified in references (1) and (2) as conditions 4PX02, recovery, and 2SD02, 5g maneuver. The first, and most important, condition is a recovery condition in which 7.4g is developed by a 66720 N (15,000 lb.) load on the parachute line which is attached at the top of the fuselage near the forward end of the center section. The inertia loading of that part of the fuselage forward of the center section produces a large bending moment, which is applied to the center fuselage section. It is this condition that sizes the center fuselage shell, Figure 2-1. The 5g maneuver in free flight produces maximum wing bending combined with concentrated loads on the keel from an external fuel tank, Figure 2-2. This condition induces local load in the fuselage in the circumferential direction, and the shell must be checked for its ability to react these loads.

It should be pointed out that the loading applied at the forward end of the center fuselage section, station 233.5, is not applied around the complete periphery of the fuselage. This is due to the geometric shape of the fuselage structure in the equipment compartment which is forward of this center section. Just forward of station 233.5, this structure extends just slightly over the upper semi-circle of the center fuselage shape, with longerons at the lower extremities, Figure 2-3. This results in some buildup of load opposite these longerons, but leaves the lower portion of the center fuselage at station 233.5 unloaded. This is important since it is at this point that maximum compressive stresses in the center fuselage occur.

3.0

STRUCTURE / MATERIAL SELECTION

At the outset it had to be recognized that three basic goals were influencing the selection of a material and type of construction for the fuselage. These, in order of importance, were low cost, improved survivability, and decreased weight.

The achievement of low cost depends on many factors such as design costs, raw material costs, manufacturing costs and if a cost comparison is to address total life cycle costs, considerations such as maintenance, replacement, repair and the like must be included. This study considers only the first, cost of designing and building the fuselage component.

One of the principle approaches used to reduce costs in designing with composite materials is to reduce total parts count. The existing metal fuselage is a semi-monocoque design, with frames and longerons. The skin is critical in buckling. In order to make a reduction in parts count and at the same time maintain a high resistance to buckling, honeycomb sandwich construction was chosen for this study. Reduction in parts count would be achieved by elimination of the intermediate frames and longerons.

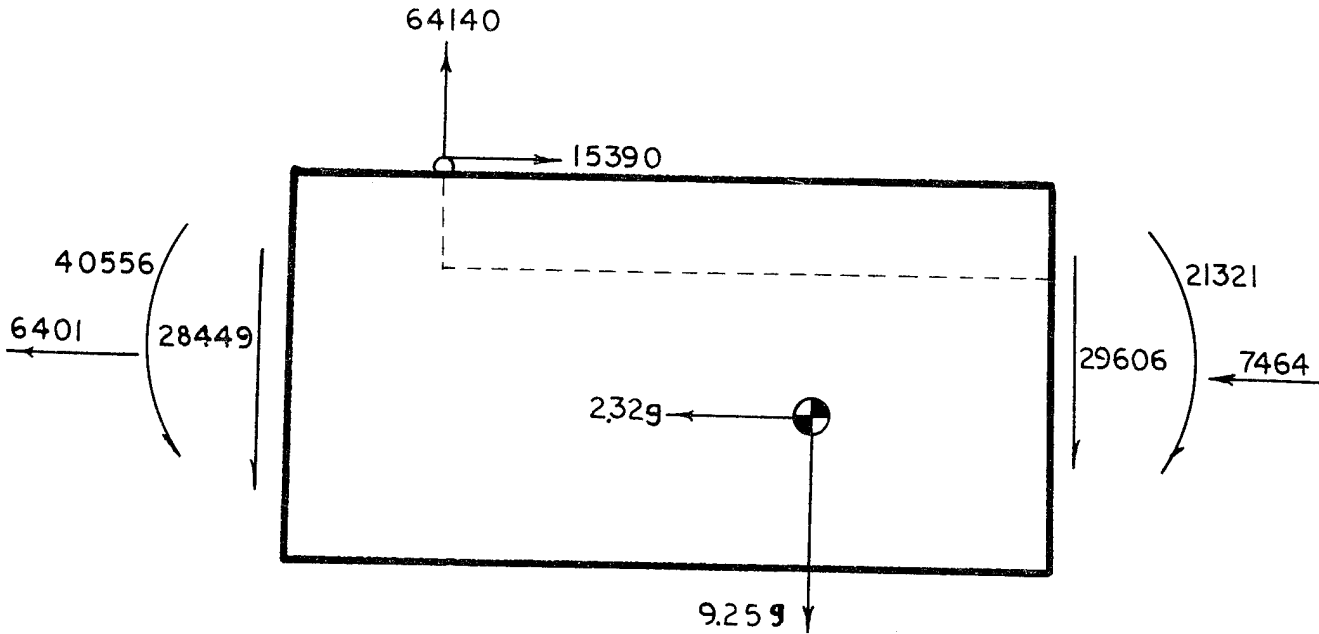
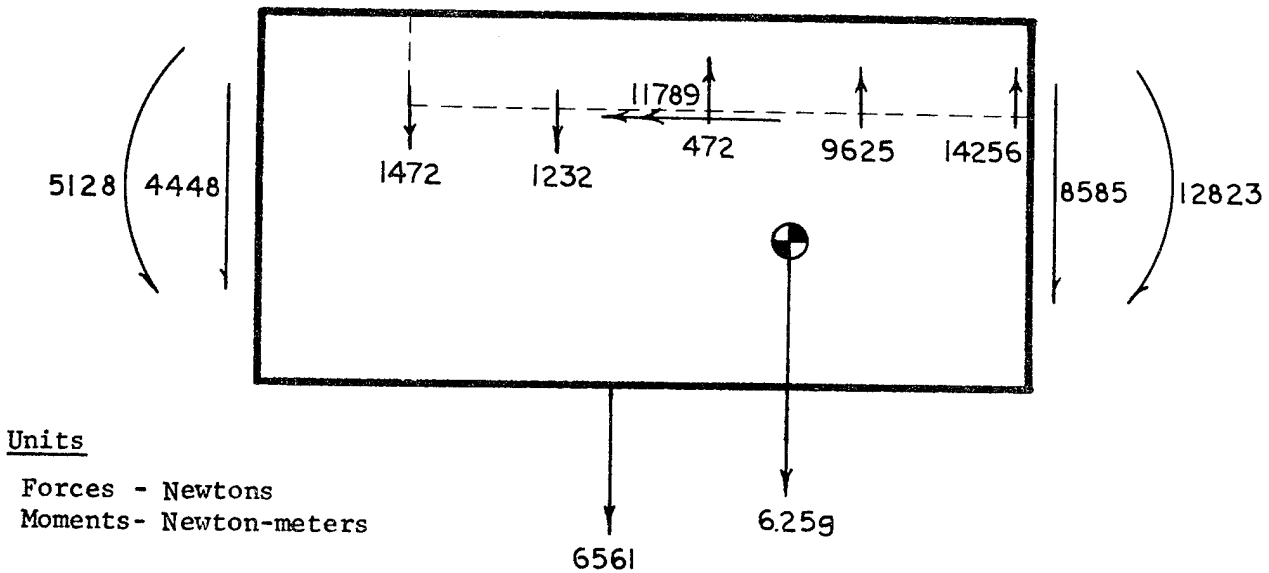

Figure 2-1. Ultimate Recovery Loads on Fuselage Section



Units

Forces - Newtons

Moments - Newton-meters

Figure 2-2. Ultimate 5g Maneuver Loads on Fuselage Half Section

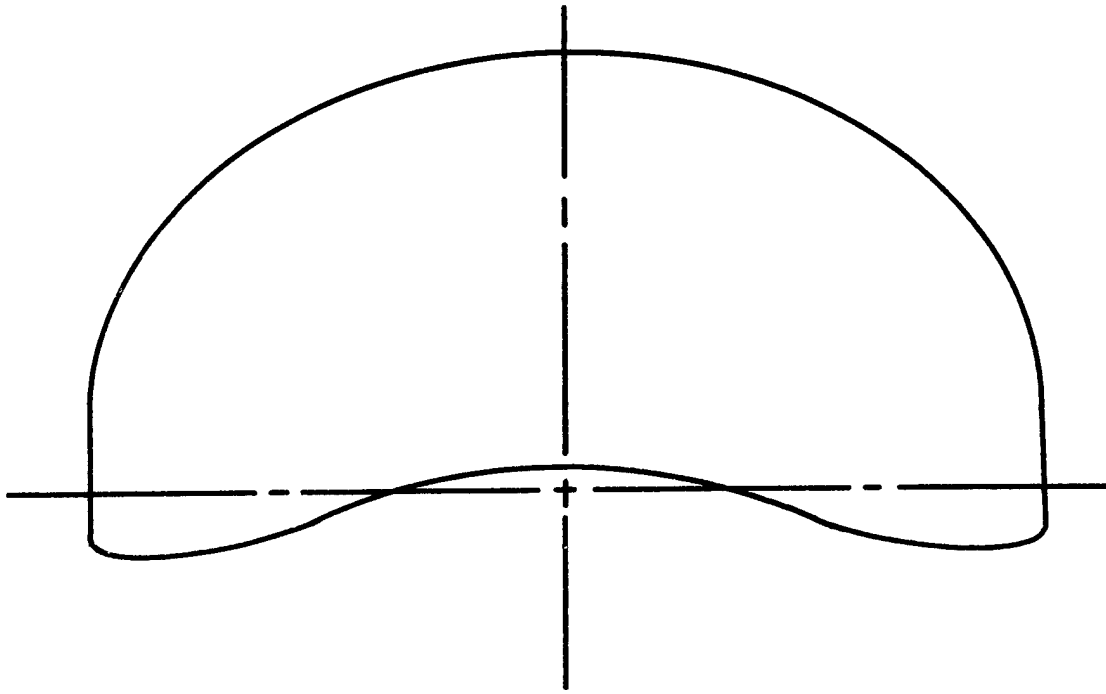

Figure 2-3. Fuselage Cross-Section Forward of Station 233.5

Candidate materials for this design were graphite-epoxy and glass-epoxy. Fuselage designs with each material in a 0° , $\pm 45^\circ$ configuration were analyzed for the critical conditions and small sandwich specimens of both were tested. As a result of this analysis and testing the use of glass-epoxy faces for the honeycomb sandwich was ruled out for the following reasons. First, the glass design is heavier than the graphite. It also appeared that it would be marginal with respect to weak direction (circumferential) strength. Its lower stiffness makes it less effective in buckling, and also forces more load into metal components which will not be replaced with composite material.

On the other hand, glass-epoxy is a tough and compliant material for fracture, and it is a good material for softening strips used for crack arrestment. In addition, successful experiments had been performed at this time using glass crack arrester strips to stop cracks in graphite-epoxy panels. Therefore, the decision was made to use a hybrid composite for the honeycomb face sheets, combining the strength and stiffness characteristics of the graphite with the toughness of the glass. The basic design is a two ply inner face with 0° graphite, $\pm 45^\circ$ glass fabric, and a 3-ply outer face also with 0° graphite but with two $\pm 45^\circ$ plies of glass fabric, the second glass ply being for added protection of the outer face against damage.

4.0 MATERIAL CHARACTERIZATION

4.1 INTRODUCTION

Material property characterization was performed on two basic hybrid material systems, one with 50% glass, representing the inner face, and one with 2/3 glass, representing the outer face. Both configurations consisted of unidirectional graphite in the 0° , or longitudinal direction, and woven glass fabric oriented in the $\pm 45^\circ$ direction. Information was desired for tension and compression in the longitudinal and transverse directions, interlaminar shear and in-plane shear.

The test specimens were fabricated using NARMCO 5209 unidirectional graphite prepreg and prepregged Hexcel F161 woven glass fabric. The materials were cured at 125°C (255°F) and 350 kPa (50 psi). For the outer face configuration, 12 plies were used, 8 glass and 4 graphite, and for the inner face configuration 8 plies were used, 4 glass and 4 graphite.

4.2 SPECIMEN CONFIGURATION

The four test specimen configurations are shown in Figure 4-1. All are basically flat laminates except for the tensile specimens which have end tabs bonded on for gripping.

4.3 RESULTS

The results of the material characterization tests are given in Tables 4-1 to 4-10. Tension and compression results in both the longitudinal and transverse directions are given, as well as in-plane and interlaminar shear, and Poisson's ratio.

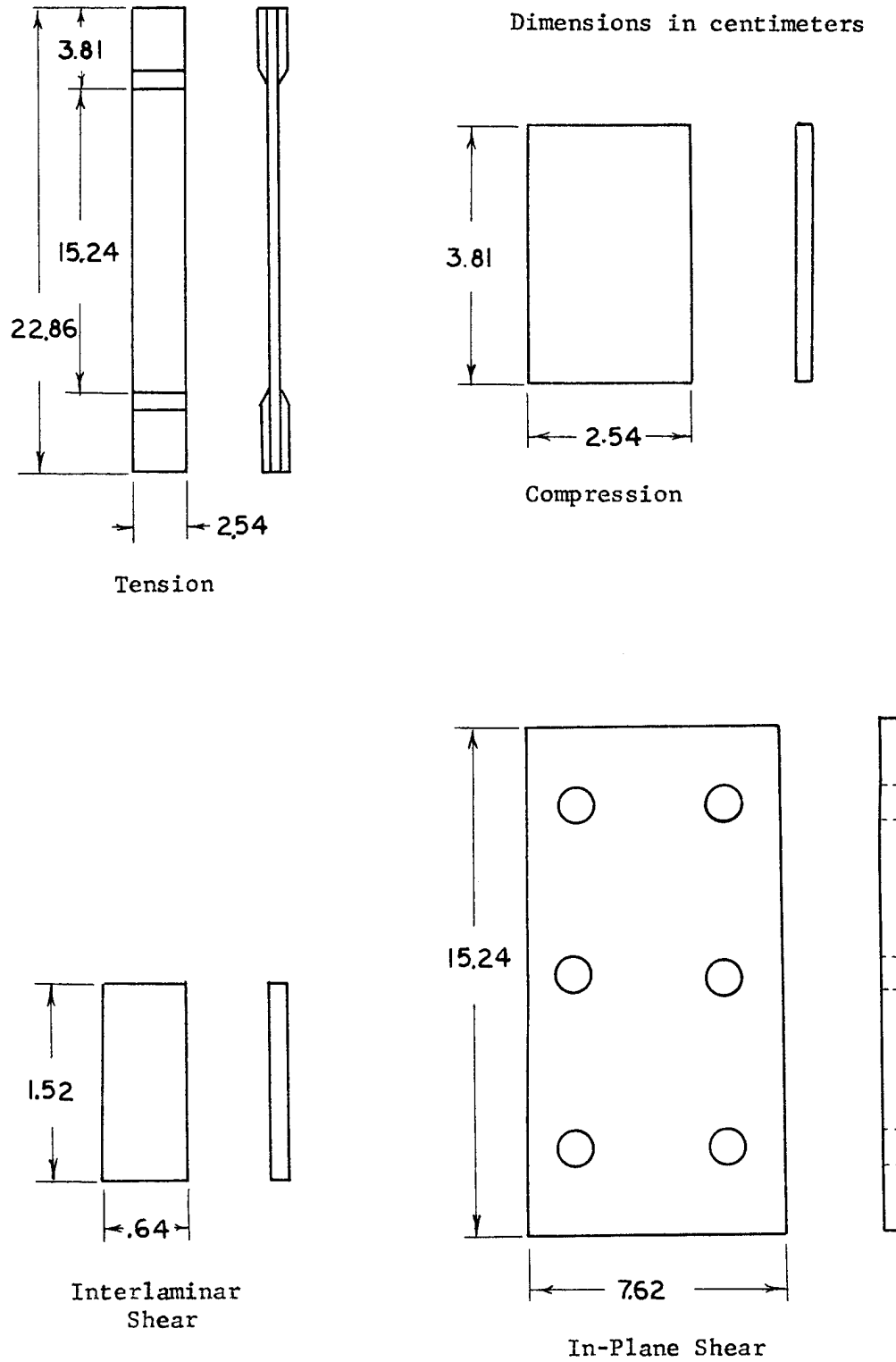

Figure 4-1. Test Specimen Configurations

TABLE 4-1HYBRID PANEL A (INNER FACE, 50% GLASS)LONGITUDINAL TENSION TESTS

<u>SPECIMEN</u>	<u>ULTIMATE STRENGTH</u>		<u>MODULUS</u>	
	<u>MPa</u>	<u>KSI</u>	<u>GPa</u>	<u>MSI</u>
1	705	102.3	72.4	10.5
2	659	95.6	69.6	10.1
3	642	93.1	-	-
4	683	99.1	69.6	10.1
5	694	100.7	-	-
6	<u>638</u>	<u>92.6</u>	<u>-</u>	<u>-</u>
Average	670	97.2	70.5	10.2
Standard Deviation	27.9	4.06	1.6	.22
Variance	779.7	16.48	2.6	.05

TABLE 4-2HYBRID PANEL A (INNER FACE, 50% GLASS)TRANSVERSE TENSION TESTS

<u>SPECIMEN</u>	<u>ULTIMATE STRENGTH</u>		<u>PRIMARY MODULUS</u>		<u>SECANT MODULUS</u>	
	<u>MPa</u>	<u>KSI</u>	<u>GPa</u>	<u>MSI</u>	<u>GPa</u>	<u>MSI</u>
1	148	21.4	-	-	-	-
2	149	21.6	14.4	2.09	8.8	1.27
3	145	21.0	14.0	2.03	9.7	1.40
4	141	20.4	12.9	1.87	9.9	1.44
5	154	22.3	-	-	-	-
6	156	22.6	-	-	-	-
Average	149	21.5	13.8	2.00	9.5	1.37
Standard Deviation	5.6	.81	.78	.114	.58	.089
Variance	31.0	.66	.60	.013	.34	.008

TABLE 4-3

HYBRID PANEL A (INNER FACE, 50% GLASS)

COMPRESSION TESTS

<u>SPECIMEN</u>	<u>LONGITUDINAL ULTIMATE STRENGTH</u>		<u>TRANSVERSE ULTIMATE STRENGTH</u>	
	<u>MPa</u>	<u>KSI</u>	<u>MPa</u>	<u>KSI</u>
1	524	76.0	221	32.1
2	-	-	206	29.9
3	530	76.9	207	30.0
4	-	-	234	34.0
5	543	78.7	216	31.4
6	548	79.5	226	32.8
Average	536	77.8	218	31.7
Standard Deviation	11.1	1.62	10.9	1.61
Variance	124.2	2.62	119.4	2.58

TABLE 4-4HYBRID PANEL A (INNER FACE, 50% GLASS)SHEAR TESTS

<u>SPECIMEN</u>	<u>INTERLAMINAR</u>		<u>STRENGTH</u>		<u>IN-PLANE</u>		<u>SECANT</u>	
	<u>STRENGTH</u>				<u>PRIMARY</u>		<u>MODULUS</u>	
	<u>MPa</u>	<u>KSI</u>	<u>MPa</u>	<u>KSI</u>	<u>GPa</u>	<u>MSI</u>	<u>GPa</u>	<u>KSI</u>
1	52	7.5	168	24.3	7.7	1.11	6.2	0.90
2	57	8.3	161	23.4	8.5	1.23	7.1	1.03
3	47	6.8	157	22.7	8.2	1.19	5.0	0.73
4	47	6.8	142	20.7	9.2	1.34	5.2	0.75
5	43	6.2	143	20.7	6.6	.96	5.6	0.81
6	52	7.6	<u>157</u>	<u>22.7</u>	<u>8.3</u>	<u>1.20</u>	<u>5.9</u>	<u>0.85</u>
7	54	7.9						
8	55	8.0						
9	55	8.0						
10	52	7.6						
11	<u>57</u>	<u>8.2</u>						
Average	52	7.5	155	22.4	8.1	1.17	8.1	0.84
Standard Deviation	4.5	.67	10.3	1.45	.88	.13	.76	.11
Variance	20.3	.45	105.1	2.09	.77	.02	.58	.01

TABLE 4-5

HYBRID PANEL A (INNER FACE, 50% GLASS)

POISSON'S RATIO

<u>SPECIMEN</u>	<u>V₁₂</u>	<u>V₂₁</u>
1	.615	-
2	.543	-
3	-	.09
4	<u>.616</u>	<u>.09</u>
Average	.591	.09
Standard Deviation	.042	0.0
Variance	.0018	0.0

TABLE 4-6HYBRID PANEL B (OUTER FACE, 2/3 GLASS)LONGITUDINAL TENSION TESTS

<u>SPECIMEN</u>	<u>ULTIMATE STRENGTH</u>		<u>MODULUS</u>	
	<u>MPa</u>	<u>KSI</u>	<u>GPa</u>	<u>MSI</u>
1	540	78.3	46.1	6.69
2	424	61.5	-	-
3	452	65.6	48.5	7.03
4	592	85.8	51.3	7.44
5	510	74.0	48.0	6.96
6	<u>442</u>	<u>71.3</u>	<u>47.0</u>	<u>6.81</u>
Average	502	72.8	48.2	6.99
Standard Deviation	60.5	8.75	1.97	.29
Variance	.3658	76.5	3.90	.08

TABLE 4-7HYBRID PANEL B (OUTER FACE, 2/3 GLASS)TRANSVERSE TENSION TESTS

<u>SPECIMEN</u>	<u>ULTIMATE STRENGTH</u>		<u>PRIMARY MODULUS</u>		<u>SECANT MODULUS</u>	
	<u>MPa</u>	<u>KSI</u>	<u>GPa</u>	<u>MSI</u>	<u>GPa</u>	<u>MSI</u>
1						
2	182	26.4	-	-	-	-
3	182	26.4	16.1	2.34	9.7	1.41
4	173	25.1	15.4	2.23	9.5	1.38
5	172	25.0	15.0	2.18	9.5	1.38
6	<u>172</u>	<u>25.0</u>	<u>14.6</u>	<u>2.11</u>	<u>9.9</u>	<u>1.43</u>
Average	176	25.6	15.3	2.22	9.7	1.40
Standard Deviation	5.3	.75	.64	.097	.19	.025
Variance	28.2	.56	.41	.009	.04	.0006

TABLE 4-8HYBRID PANEL B (OUTER FACE, 2/3 GLASS)COMPRESSION TESTS

<u>SPECIMEN</u>	<u>LONGITUDINAL ULTIMATE STRENGTH</u>		<u>TRANSVERSE ULTIMATE STRENGTH</u>	
	<u>MPa</u>	<u>KSI</u>	<u>MPa</u>	<u>KSI</u>
1	370.2	53.7	248	36.0
2	496	71.9	267	38.7
3	-	-	236	34.3
4	481	69.8	199	28.9
5	494	71.7	243	35.2
6	<u>418</u>	<u>60.6</u>	<u>-</u>	<u>-</u>
Average	472	65.5	239	34.6
Standard Deviation	36.8	8.08	24.9	3.36
Variance	1352	65.30	622.3	12.93

TABLE 4-9HYBRID PANEL B (OUTER FACE, 2/3 GLASS)INTERLAMINAR SHEAR TESTS

<u>SPECIMEN</u>	<u>ULTIMATE STRENGTH</u>	
	<u>MPa</u>	<u>KSI</u>
1	59	8.6
2	56	8.1
3	57	8.3
4	57	8.3
5	56	8.1
6	55	8.0
7	56	8.1
8	54	7.9
9	54	7.9
10	57	8.3
11	-	-
12	57	8.2
13	<u>58</u>	<u>8.4</u>
Average	56	8.2
Standrad Deviation	1.5	.22
Variance	2.2	.05

TABLE 4-10HYBRID PANEL B (OUTER FACE, 2/3 GLASS)POISSON'S RATIO

<u>SPECIMEN</u>	<u>ν_{12}</u>	<u>ν_{21}</u>
1	.625	-
2	-	-
3	.625	.134
4	-	-
5	-	.134
Average	.625	.134

5.0 FUSELAGE DESIGN AND ANALYSIS

5.1 INTRODUCTION

Previous sections of this report have described the point design vehicle, its critical flight conditions and the design concept and materials being used. Complete specification of the design details, and substantiation of the design was accomplished by the stress and stability analysis of the section, the testing of small subcomponents representing the edge closeout design, the fabrication and testing of a full-scale cylindrical shell of the same basic design as the fuselage section, and finally the fabrication and testing of the actual fuselage center section installed on the BQM-34E RPV and subjected to the critical flight conditions. These subjects will be covered in this and the remaining sections of this report, starting with the stress and stability analysis in this section.

5.2 DESIGN DESCRIPTION

The basic design for the composite fuselage is a honeycomb sandwich structure, Figure 5-1, consisting of a 6.4mm (1/4 in.) thick aluminum honeycomb core and two hybrid composite faces. The inner face is made up of one ply of glass fabric next to the core, with the fibers oriented at $\pm 45^\circ$ to the longitudinal direction, and one ply of unidirectional graphite oriented at 0° . The outer face is similar with a second layer of $\pm 45^\circ$ glass fabric on the outer surface for additional impact and damage resistance. All areas near bulkheads, doors and other attachments have additional plies for reinforcement and introduction of load into the sandwich. The general approach to this reinforcement was to make each face in the reinforced areas four plies thick, two plies of unidirectional graphite and two plies of glass fabric. The closeout area contained additional plies for load introduction and for riveting, with a total of 16 plies, 8 unidirectional graphite and 8 glass fabric, at the areas where the two faces come together, Figure 5-2.

Both faces contain integral crack arrester strips which run in the 0° , or fore/aft, direction of the fuselage. They are formed by replacing the 0° graphite epoxy with 0° glass epoxy, so that the arrester strip is all glass epoxy while the primary material is a hybrid of both graphite and glass epoxy. The entire layout is shown in Figure 5-3. Table 5-1 lists the materials used.

This composite design for the center fuselage is a replacement primarily for the metal skins of the existing production design. However, due to the stiffness of the sandwich construction, the intermediate frames and the two longerons on either side of the fuselage can also be eliminated. In order to make sure that no concentrated loading is applied to the section in the circumferential direction from the wing attachment bolts, the middle six bolts and attachment fittings are eliminated and the composite design is based on a four bolt wing attachment, rather than a ten bolt as exists on the metal design. Figure 5-4 shows a comparison of the metal and composite designs.

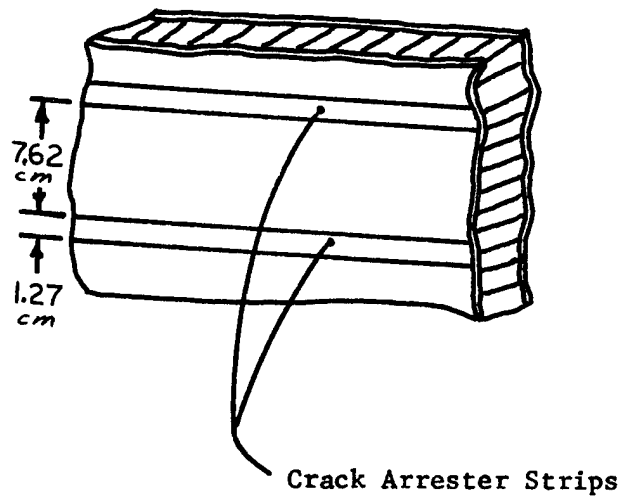
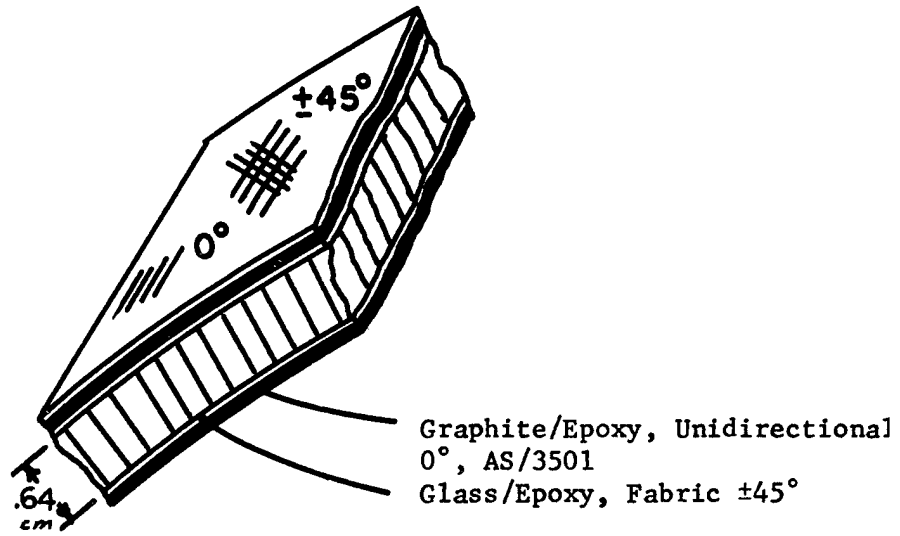

Figure 5-1. Fuselage Honeycomb Sandwich Design

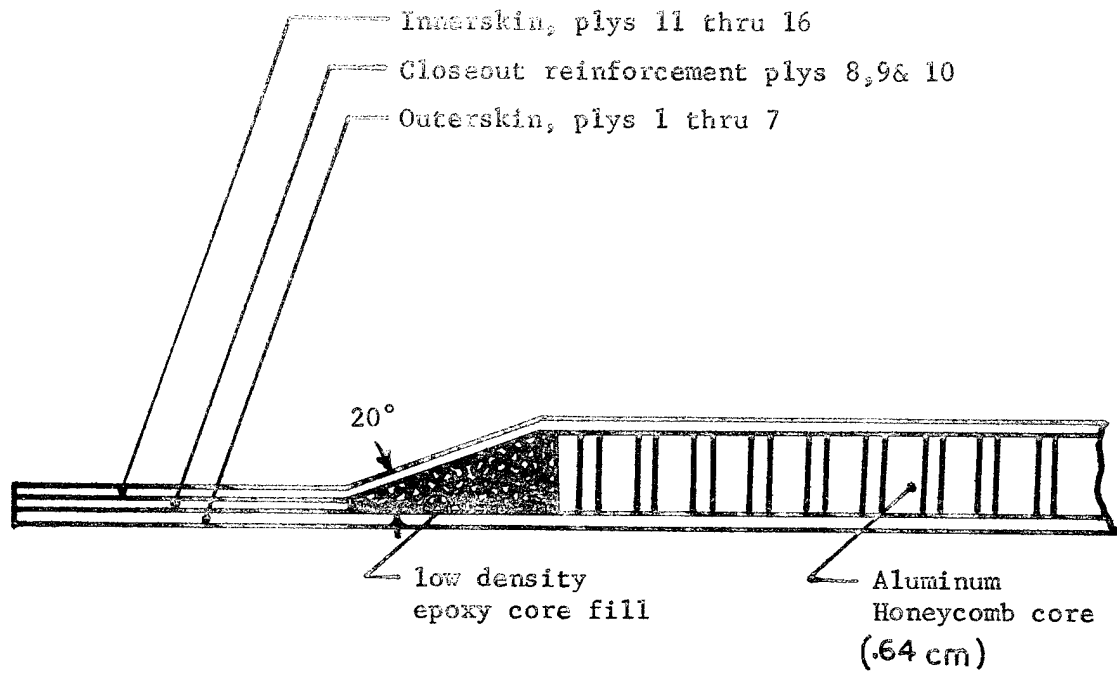

Figure 5-2. Closeout Section Design

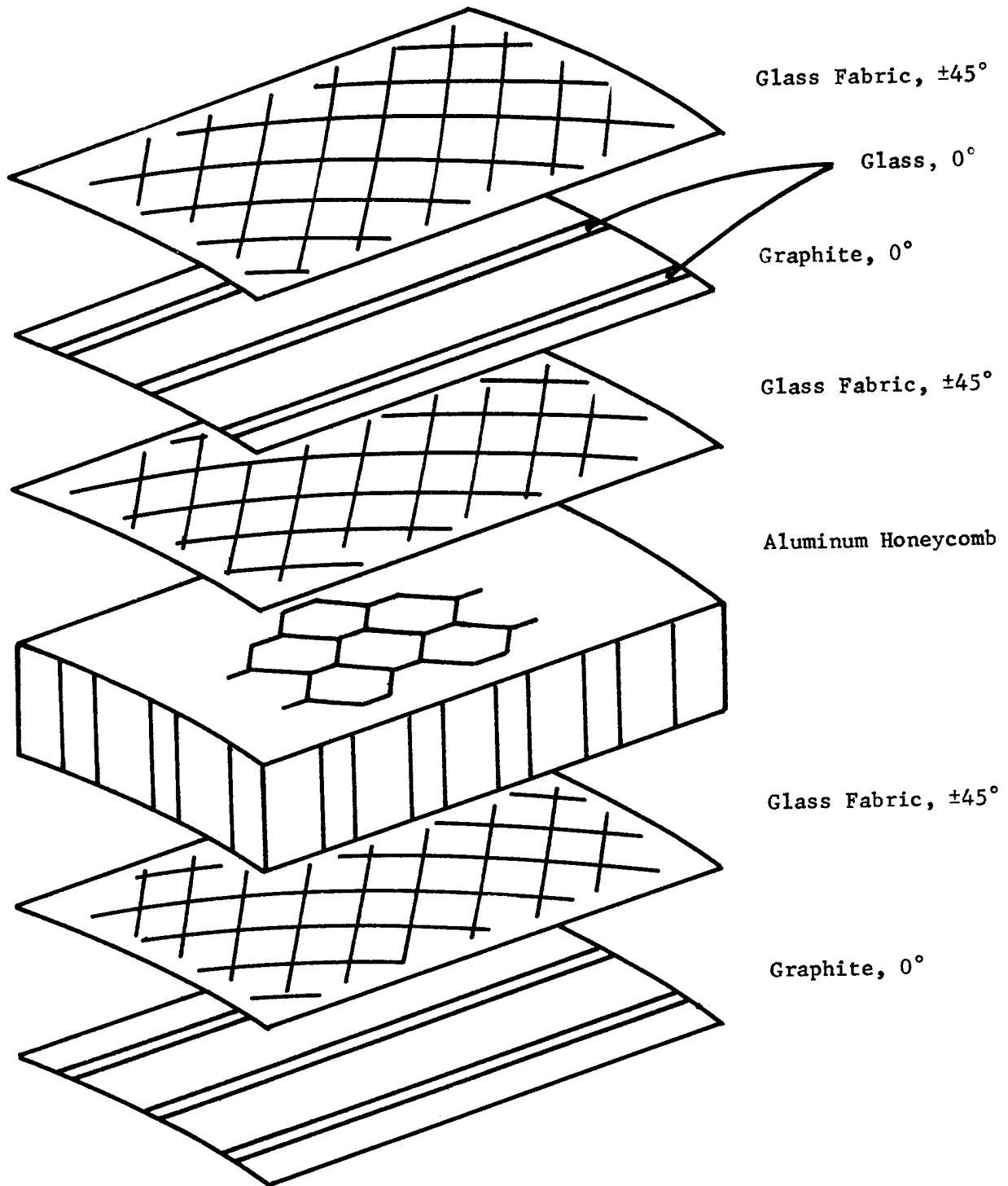

Figure 5-3. Hybrid Sandwich Layup

TABLE 5-1

HYBRID COMPOSITE SANDWICH MATERIALS

FACES

Hercules AS/3501 Unidirectional Graphite Epoxy

CORE

Hexcel 1/8 - 5056 - .0007 - 3.1 Aluminum

ADHESIVE

Fuselage - Narmco Metlbond 329-7

CORE FILLER

Furane Epocast 1310

ARRESTER STRIPS

3M Scotchply Glass SP-250-SF1

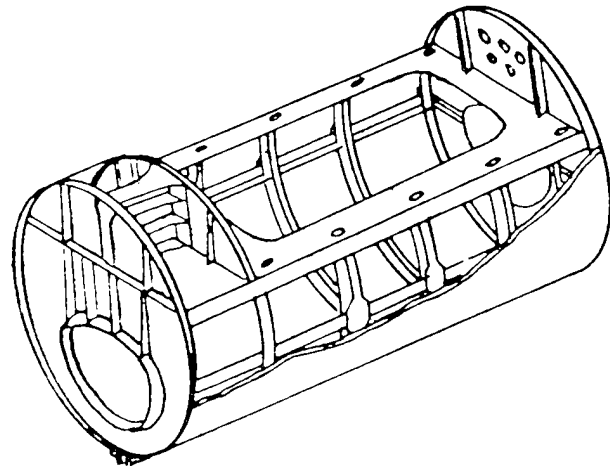

EXISTING METAL DESIGN

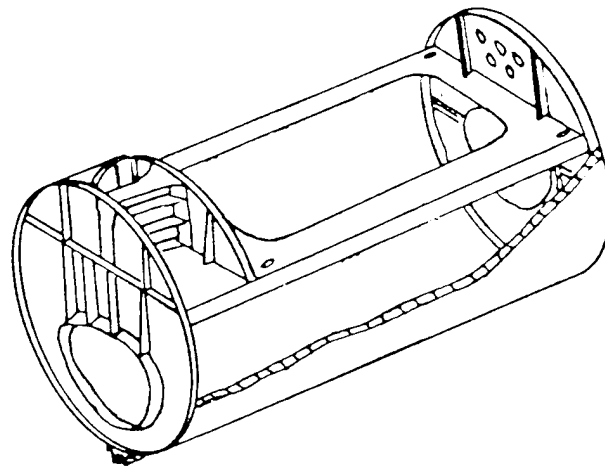

COMPOSITE DESIGN

Figure 5-4. Comparison of Metal and Composite Center Fuselage Designs

Complete details of the fuselage design are shown in Figures 5-5 to 5-8 which are the fabrication drawings for the left and right side panels, the left side access door and the bottom fuel tank access door. These four parts comprise the center section composite design. Aside from the parts which have been eliminated, as previously discussed, the rest of the center section remains metal. Figure 5-8a shows composite panel attachment to metal substructure.

5.3 MATERIAL PROPERTIES

Two sets of composite material properties were required for designing this structure; one set, called outer face properties, used for the 3 ply outer face of the sandwich, and the other set, called inner face properties, used for the 2 ply inner face, the 4 ply inner and outer faces in those areas where additional material was added for reinforcement and the 16 ply solid laminate sections. The properties are given in Table 5-2. The basis of these properties is as follows. Allowable strengths were determined by reducing the average values from the characterization tests by 30%. This allows for scatter in the data and provides a measure of conservatism. The modulus data from the tests were analytically modified to account for the fact that the material characterization specimens were made from .190 mm (.0075 in.) graphite fibers while the actual fuselage was to be made from .152 mm (.006 in.) fiber. This caused the longitudinal modulus to be reduced about 10% from the test values and the transverse and shear moduli to increase slightly.

5.4 NASTRAN MODEL

Figure 5-9 shows the modeling of the skin portion of this center section. In addition, the bulkheads at stations 233.5 and 274.1, the shear fitting between stations 233.5 and 241.8, the partial bulkhead at station 241.8, the strongback, the overwing fairing formers, and the roof structure were also modelled. These are shown in Figures 5-10 to 5-15. In all this modeling, advantage is taken of the left/right symmetry of the fuselage.

For the plate elements which make up the composite fuselage skin elements, general triangular plate elements (CTR1A1) were used for the sandwich elements, and CTR1R2 for the solid laminates. The first is useful for sandwich construction since it allows the specification of separate properties for membrane, bending and shear behavior. As previously mentioned, two sandwich configurations were used, the basic sandwich consisting of a 3 ply outer face and 2 ply inner face, and a reinforced section where both faces are 4 plies. Table 5-3 shows the properties for each configuration.

All the existing metal parts were modelled by taking dimensions from manufacturer's drawings for the BQM-34E vehicle. A complete set of the NASTRAN bulk data for the model is given in Appendix 1.

Only the center portion of the wing, from the bolt line to the centerline, was included in this model since only that part affected the fuselage structural behavior. That model is shown in Figure 5-16. The production BQM-34E utilizes 10 bolts, 5 per side, to attach the wing to the fuselage. In this

NADC-77149-30

DWG. NO. 667A107 "RIGHT SKIN PANEL" WILL BE FOUND IN THE
BACK OF THIS REPORT

NADC-77149--30

DWG. NO. 667A107 "LEFT SKIN PANEL" WILL BE FOUND IN THE
BACK OF THIS REPORT

NADC-77149-30

DWG. NO. 667A107 "FUEL TANK ACCESS DOOR" WILL BE FOUND
IN THE BACK OF THIS REPORT

NADC-77149--30

DWG. NO. 667A107 "ACCESS DOOR - BQM 34E CENTER FUSELAGE SECTION -
HYBRID COMPOSITE DESIGN" WILL BE FOUND IN THE BACK OF THIS REPORT

NADC-77149-30

DWG. NO. 667A109 "ATTACHMENTS" WILL BE FOUND IN THE BACK
OF THIS REPORT

TABLE 5-2MATERIAL PROPERTIES USED FOR DESIGN

	<u>Inner Face</u>		<u>Outer Face</u>	
	SI	English	SI	English
E_L	63.4 GPa	9.2×10^6 psi	43.4 GPa	6.3×10^6 psi
E_T	15.2 GPa	2.2×10^6 psi	15.2 GPa	2.2×10^6 psi
G	9.0 GPa	1.3×10^6 psi	8.3 GPa	1.2×10^6 psi
ν_{12}	.59	.59	.62	.62
ν_{21}	.09	.09	.13	.13
F_L^t	469 MPa	68.0 KSI	352 MPa	51.0 KSI
F_T^t	104 MPa	15.1 KSI	123 MPa	17.0 KSI
F_L^c	376 MPa	54.5 KSI	316 MPa	45.8 KSI
F_T^c	153 MPa	22.2 KSI	167 MPa	24.2 KSI
F_S	108 MPa	15.7 KSI	108 MPa	15.7 KSI
F_S^{11}	36 MPa	5.2 KSI	39 MPa	5.7 KSI

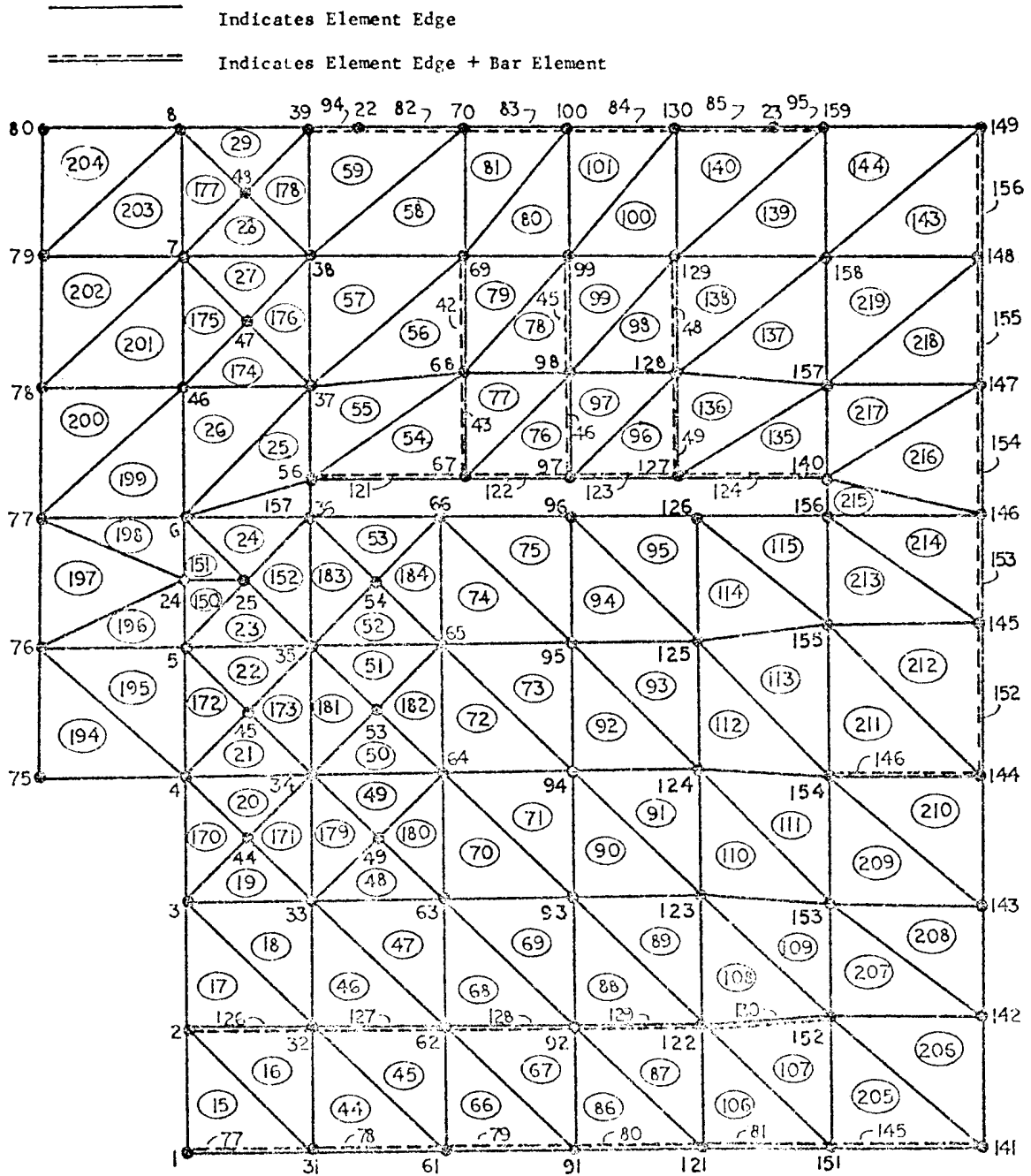

Figure 5-9. Fuselage Center Section Skin Model

- Indicates Element Edge
- Indicates Element Edge + Bar Element
- Indicates Bar Element

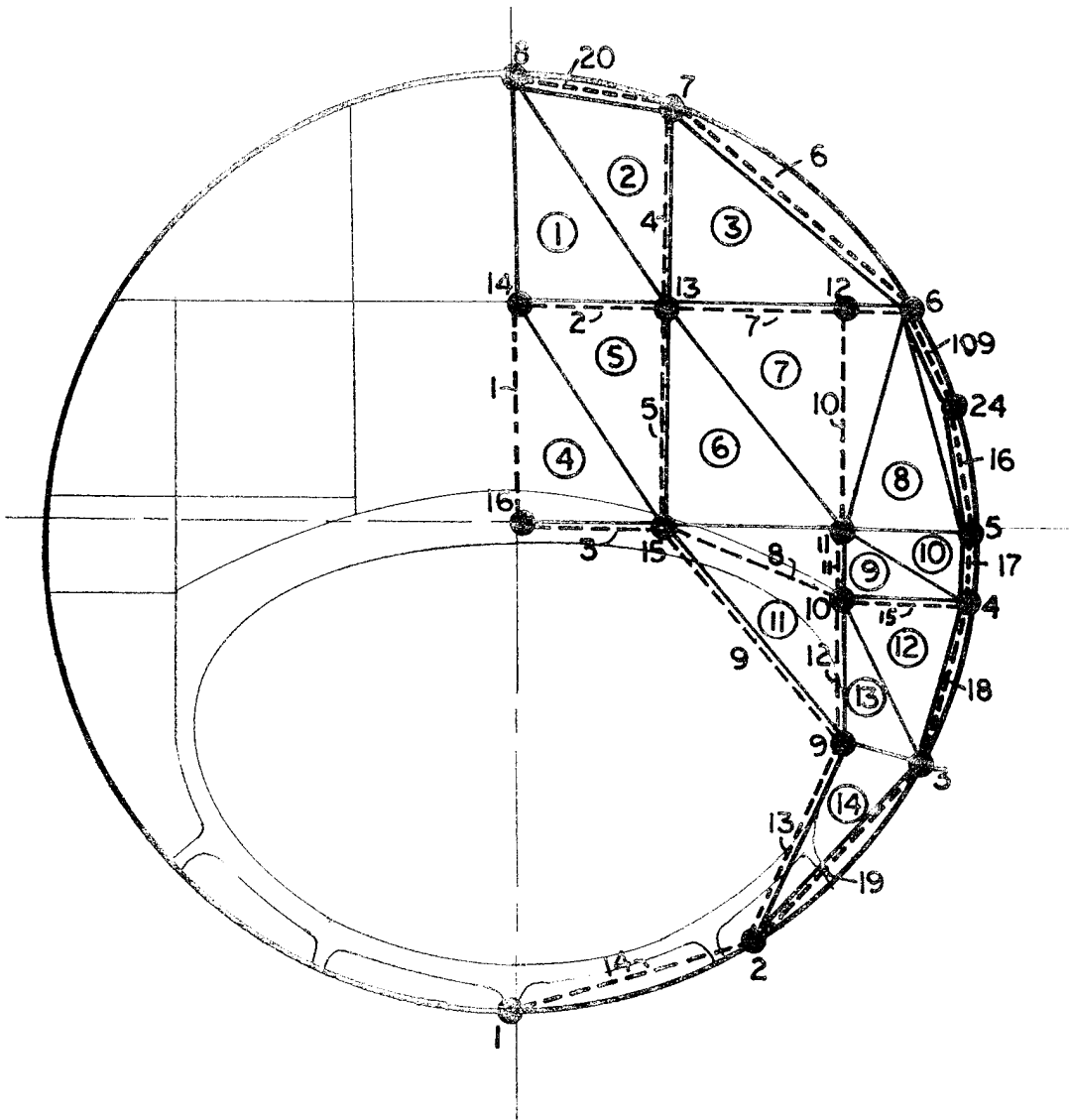
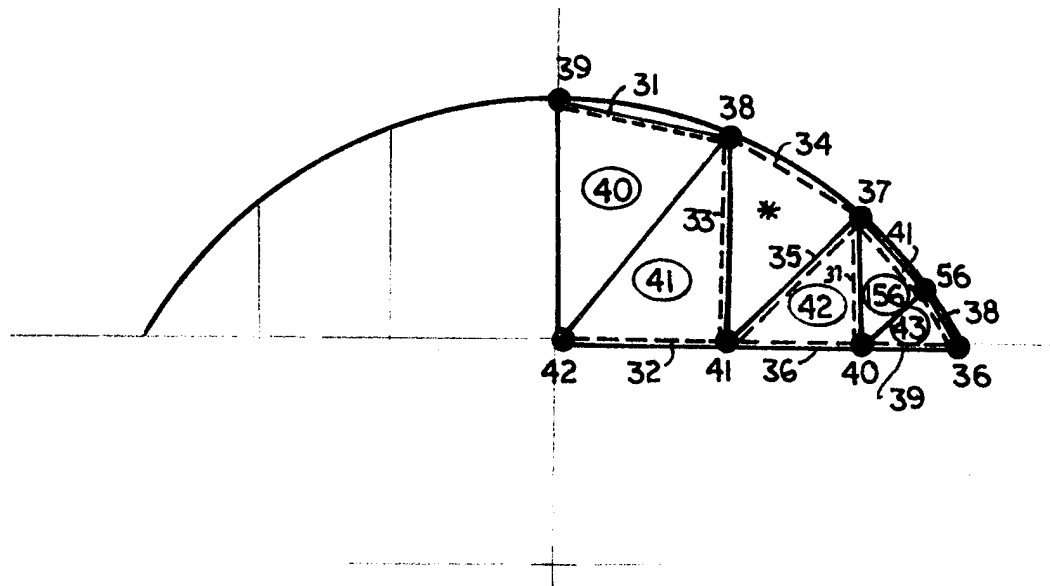

Figure 5-10. Bulkhead 233.5 Model

- Indicates Element Edge
- ===== Indicates Element Edge + Bar Element
- Indicates Bar Element



* NO ELEMENT

Figure 5-11. Bulkhead 241.8 Model

- Indicates Element Edge
- Indicates Element Edge & Bar Element
- - - - - Indicates Bar Element

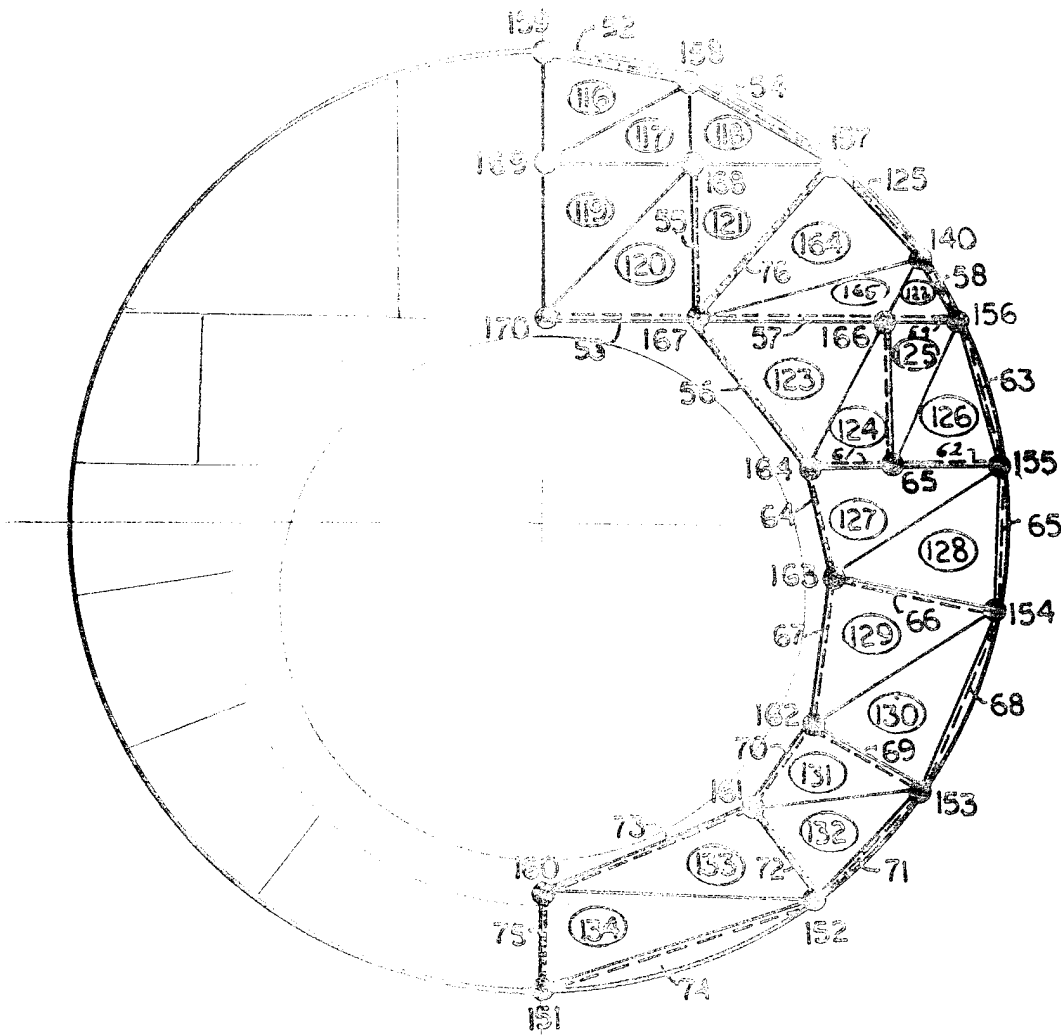

Figure 5-12. Bulkhead 274.1 Model

———— Indicates Element Edge

==== Indicates Element Edge + Bar Element

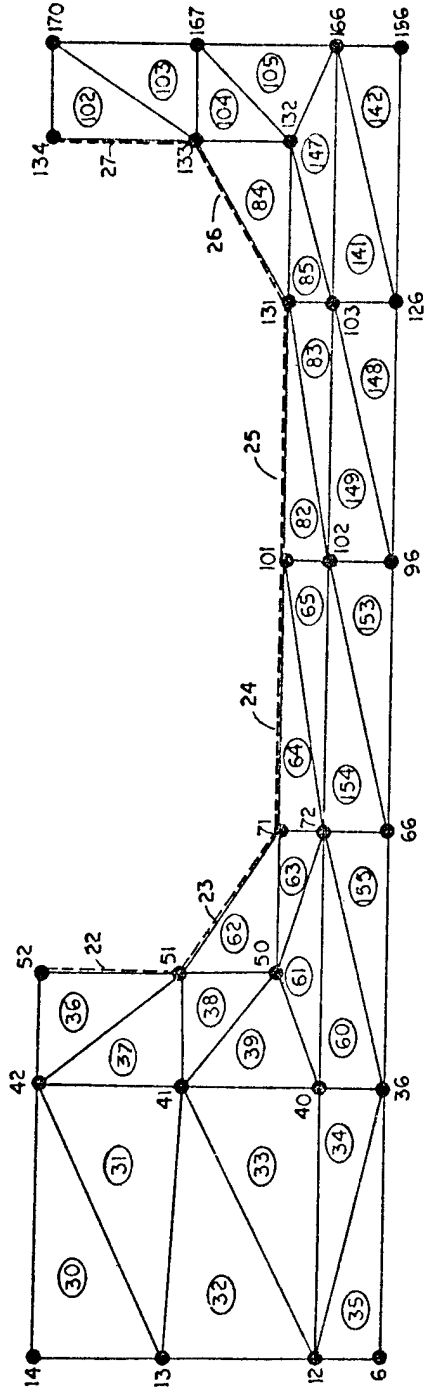

Figure 5-13. Roof Structure Model

Indicates Element Edge

Indicates Element Edge + Bar Element

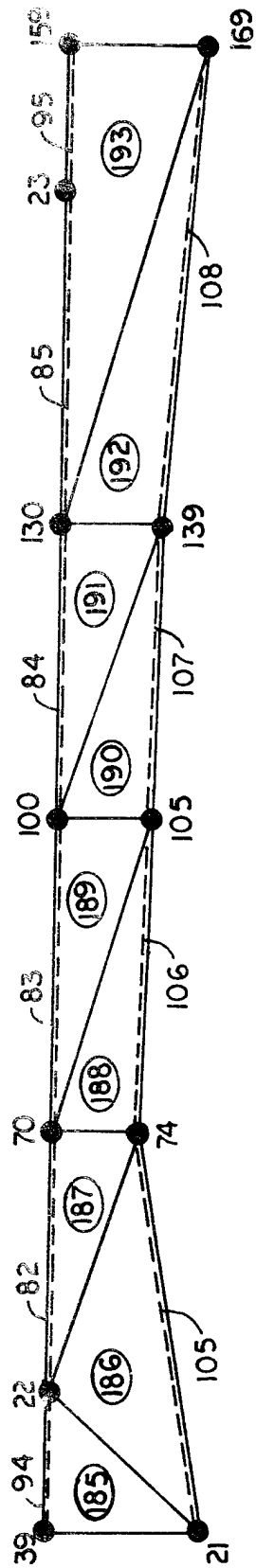

Figure 5-14. Strongback Model

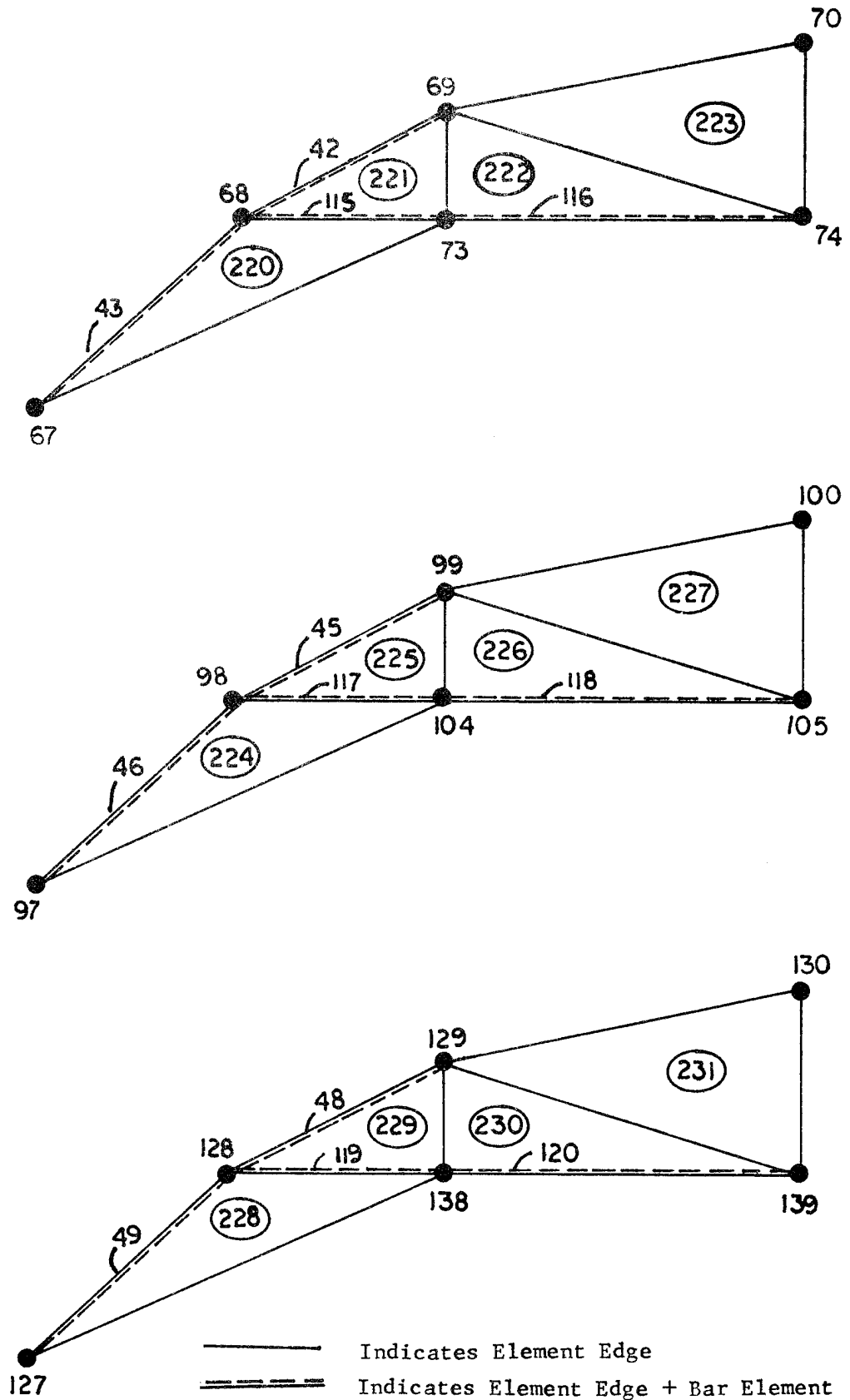

Figure 5-15. Overwing Fairing Formers Model

TABLE 5-3

HYBRID COMPOSITE PLATE ELEMENT PROPERTIES

<u>PROPERTY</u>	<u>BASIC SECTION</u>	<u>REINFORCED SECTION</u>	<u>SOLID LAMINATE</u>
<u>MEMBRANE PROPERTIES</u>			
Thickness	1.10 (.042)	1.63 (.064)	3.25 (.125)
G ₁₁	51.0 (7.4)	63.4 (9.2)	68.2 (9.9)
G ₁₂	6.2 (.90)	5.7 (.83)	6.1 (.89)
G ₂₂	14.5 (2.1)	15.2 (2.2)	15.8 (2.3)
G ₃₃	7.6 (1.1)	7.6 (1.1)	7.6 (1.1)
<u>BENDING PROPERTIES</u>			
Moment of Inertia	303.8 (.00073)	520.3 (.00125)	
G ₁₁	59.3 (8.6)	68.2 (9.9)	
G ₁₂	6.2 (.90)	6.1 (.89)	Only one set
G ₂₂	15.2 (2.2)	15.8 (2.3)	of properties
G ₃₃	7.6 (1.1)	7.6 (1.1)	required for
Z ₁	2.64 (.104)	3.58 (.141)	homogeneous
Z ₂	-4.24 (-.167)	-3.58 (-.141)	plate elements
<u>TRANSVERSE SHEAR PROPERTIES</u>			
Thickness	6.35 (.25)	6.35 (.25)	
E	.67 (.097)	.67 (.097)	
G	.22 (.0325)	.22 (.0325)	

Dimensions are given in mm. and (in.).
 Moduli are given in GPa and (10⁶ psi).
 Moment of inertia is given in mm⁴ and (in.⁴).

TABLE 5-3 (Cont'd)

G_{ij} is defined by:

$$\begin{Bmatrix} \sigma_1 \\ \sigma_2 \\ \sigma_{12} \end{Bmatrix} = \begin{bmatrix} G_{11} & G_{12} & G_{13} \\ G_{12} & G_{22} & G_{23} \\ G_{13} & G_{23} & G_{33} \end{bmatrix} \begin{Bmatrix} E_1 \\ E_2 \\ E_3 \end{Bmatrix}$$

$$G_{13} = G_{23} = 0$$

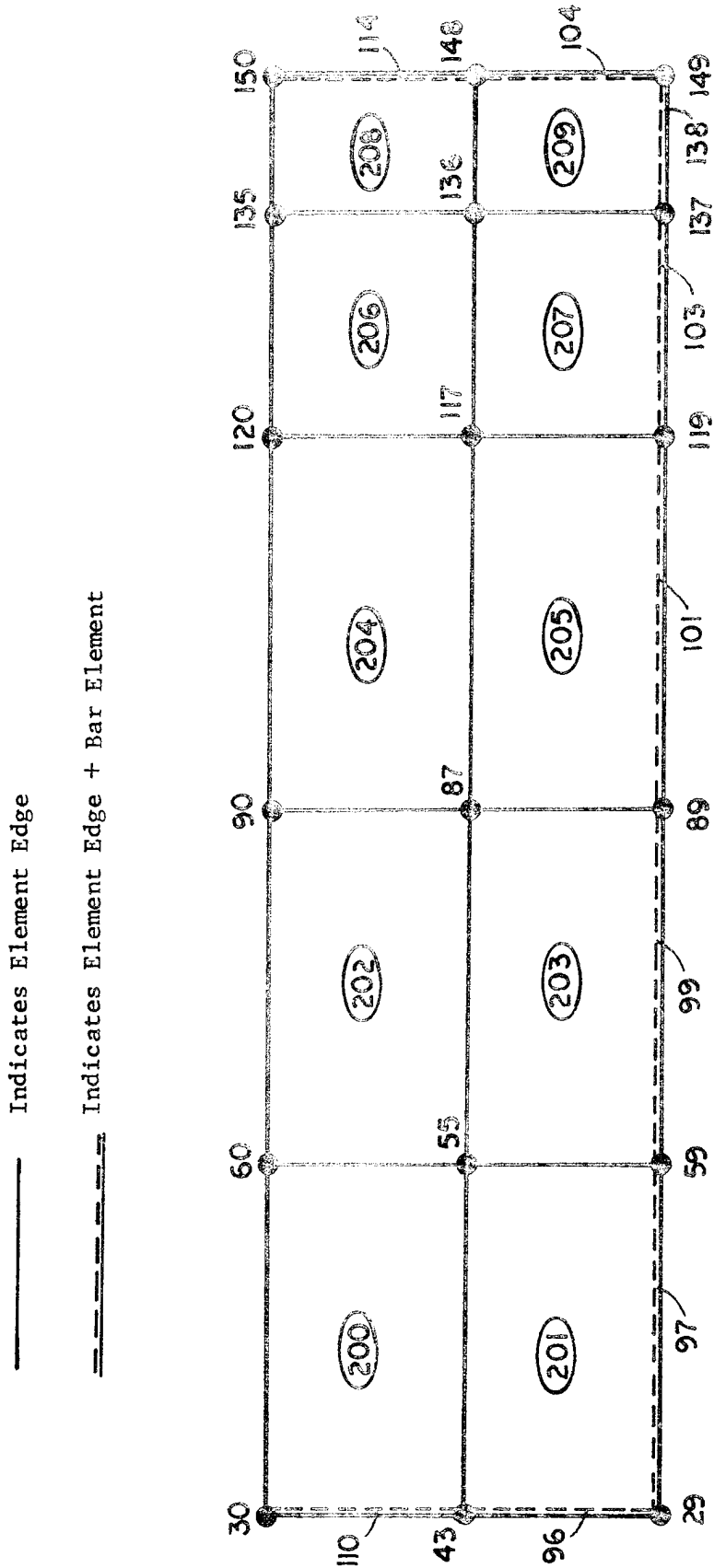

Figure 5-16. Wing Model

design of the composite fuselage the middle three on each side were removed and the design was based on a 4 point wing attachment. These bolts were modelled as scalar elements.

NASTRAN runs were made for the two critical loading conditions previously discussed. The main concern in these runs was the stresses developed in the composite material structure. The stresses in the metal parts were examined and no area of concern was found. Figures 5-17 to 5-19 give the stresses in the composite structure for the recovery condition. Table 5-4 gives a summary of the maximum stresses. In both cases the maximum stresses are compression in the forward part of the fuselage section at the point of discontinuity of the forward fuselage.

5.5 BUCKLING DESIGN

5.5.1 Methodology

The buckling analysis of this design was complicated by the fact that it is a sandwich structure, the faces are of unequal thickness, they are both orthotropic, the elastic properties of the two faces are different, and the sandwich section is not constant, that is, some areas have the additional plies in the faces for reinforcement. No one analytical method was found which pertained directly to this case, and so several techniques were investigated. These techniques are those given in references 4 to 9.

A comparison of all these methods was made for both a complete cylindrical shell and for cylindrical panels. The method of reference 4 was applied in two different ways, one with a sandwich whose faces were the thicker outer face and one where the sandwich faces were the inner face thickness and properties. The former method and the methods of references 5 and 6 all gave close to the same results, while the latter and the methods of references 7 to 9 all gave close to the same results. The first set of results, however, was approximately 70% higher, and so, in order to minimize risk, it was decided not to use these methods. The second set of methods were examined in more detail and the following were selected for analyzing the buckling of the fuselage panels, and the cylindrical shell test component which will be discussed in a later section of this report.

Cylinder:

Axial Buckling Load, N_x -

$$N_x = N_o \left(\frac{N_x}{N_o} \right) \quad \emptyset \quad (1)$$

where

$$\frac{N_x}{N_o} = f \left(\frac{N_x}{N_q} \right) \quad \text{from Figure 10 of reference 8.}$$

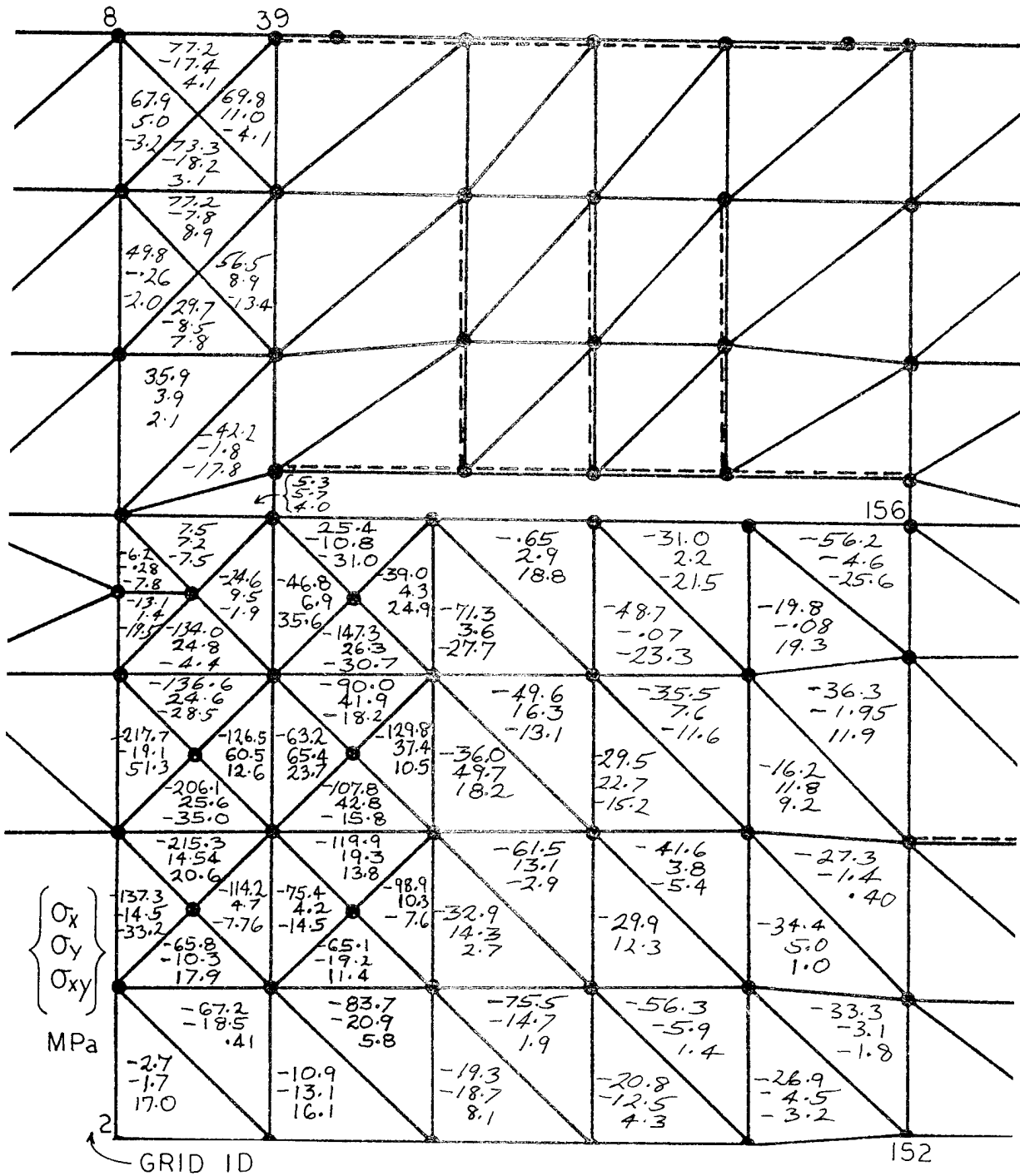

Figure 5-17. Outer Face Stresses - Recovery Condition

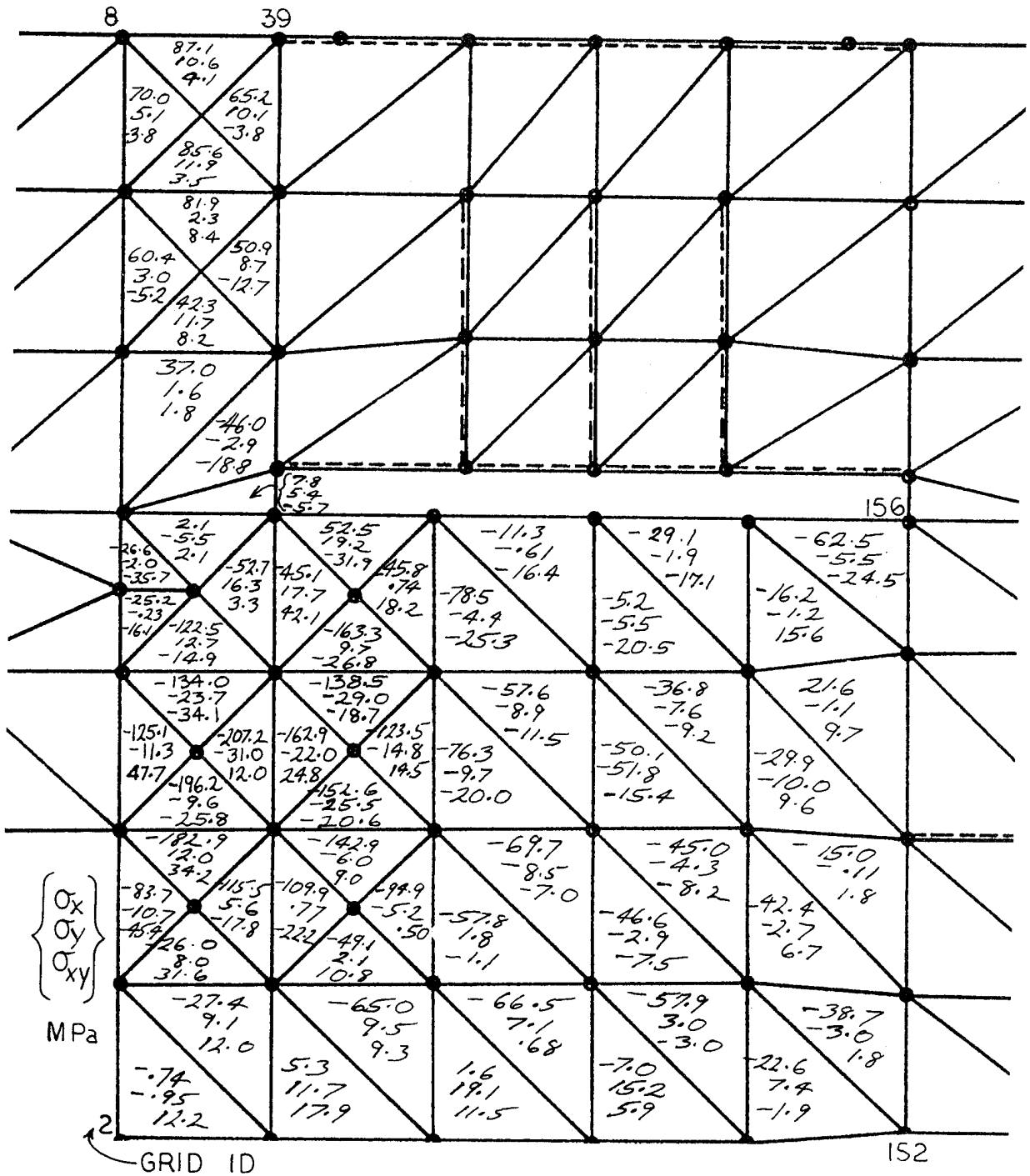
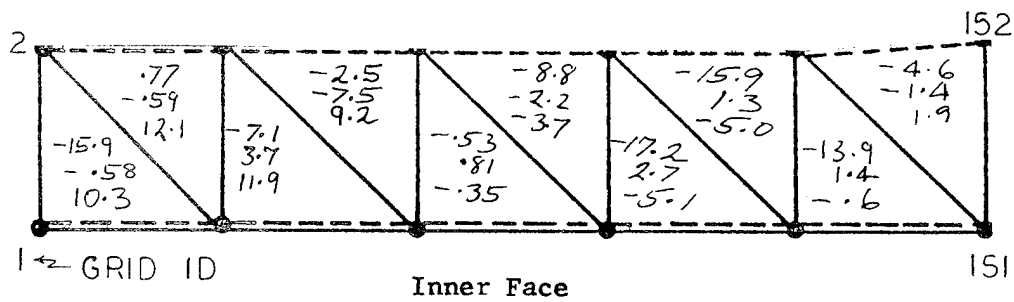
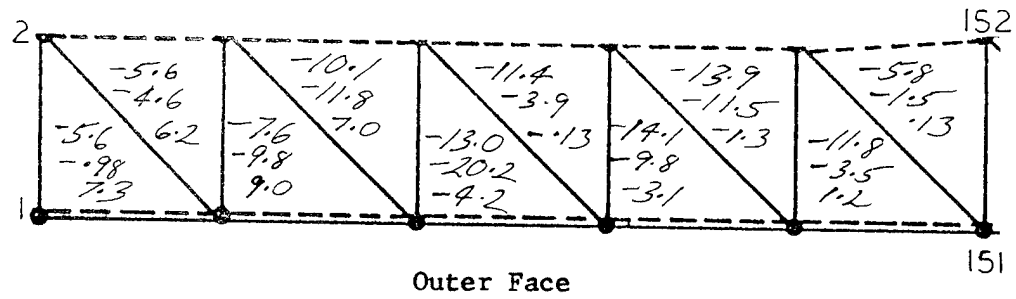

Figure 5-18. Inner Face Stresses - Recovery Condition



$$\left\{ \begin{array}{l} \sigma_x \\ \sigma_y \\ \sigma_{xy} \end{array} \right\}$$

MPa

Figure 5-19. Access Door Stresses - Recovery Condition

TABLE 5-4

SUMMARY OF MAXIMUM STRESSES

RECOVERY

	Outer Face (3 Ply)		Inner Face (2 Ply)	
	MPa	PSI	MPa	PSI
<u>AXIAL:</u>				
Tension	*	*	87.1	12635
Compression	162.8	23621	217.7	31589
<u>CIRCUMFERENTIAL:</u>				
Tension	2.1	301	65.4	9486
Compression	29.0	4205	31.0	4493
<u>SHEAR</u>	24.8	3594	51.3	7439

* NOTE - All axial stresses in outer face 3 ply elements were in compression

$$N_o = \frac{2\gamma \bar{E}}{\sqrt{1 - \nu_1 \nu_2}} \frac{h}{r} \sqrt{t_1 t_2}$$

$$\phi = \left\{ G_{LT} \left[1 + (\nu_{LT} + \nu_{TL})^{1/2} \right] / (E_L E_T)^{1/2} \right\}^{1/2} \quad (\text{reference 4})$$

$$D_q = G_{xz} \frac{h^2}{h - \frac{1}{2}(t_1 + t_2)}$$

ϕ is a face shear correction factor taken from reference 4, and γ is a correlation factor defined by Figure 11 of reference 8. D_q is a transverse shear stiffness parameter for the sandwich. The other quantities are defined as follows:

G_{xz} - shear modulus of core longitudinal-transverse plane

h - sandwich depth measured center to center of faces

t_1, t_2 - sandwich face thicknesses

r - radius of cylinder

G_{LT} - in-plane shear modulus of sandwich face

E_L - longitudinal modulus of sandwich face

E_T - circumferential modulus of sandwich face

ν_{LT}, ν_{TL} - Poisson's ratio of sandwich face

\bar{E} in the equation for N_o was determined as follows:

$$\bar{E} = \frac{\left(\sqrt{E_L E_T} \right)_{\text{outer face}} + \left(\sqrt{E_L E_T} \right)_{\text{inner face}}}{2}$$

The determination of an equivalent isotropic modulus by the square root technique used here was recommended in reference 10 and is also reflected in the equation for ϕ from reference 4.

Shear Buckling Load, N_{xy} -

$$N_{xy} = \frac{.34 (\gamma Z)^{3/4} \pi^2 D_1}{L^2} \quad (2)$$

where

$$Z = \frac{2L^2}{rh} \sqrt{1 - \nu_{LT} \nu_{TL}}$$

$$D_1 = \frac{(\sqrt{E_L E_T})_o t_o (\sqrt{E_L E_T})_i t_i h^2}{(1 - \gamma_{LT} \gamma_{TL}) [(\sqrt{E_L E_T})_o t_o + (\sqrt{E_L E_T})_i t_i]}$$

L = length of cylinder

$\gamma = .586$ (reference 8)

Subscript "o" refers to outer face

Subscript "i" refers to inner face

Equation (2) above may be used for rigid core where $\gamma D_1/L^2 D_q \approx 0$ and $\gamma Z > 170$. Otherwise, Figure 14 of reference 8 should be used to determine k_{xy} , and

$$N_{xy} = \frac{k_{xy} \pi^2 D_1}{L^2} \quad (3)$$

Cylindrical Panel:

Axial Buckling Load, N_x -

$$N_x = KN_o \left(\frac{N_x}{N_o} \right) \phi \quad (4)$$

Except for the K factor this is identical to equation (1) for a cylinder. Comparative calculations of cylinders and panels using the methods of reference 6 indicate that for a panel with simply-supported edges the buckling load is the same as for a cylinder and, therefore, for this case $\phi = 1$.

For the case of clamped edges, section 5 of reference 9 was used to determine the ratio of clamped buckling load to simply-supported buckling load. The procedure for this is as follows:

- a. Determine K_{mo} from Figure 5-22 (reference 9)
- b. Calculate K_F

$$K_F = \frac{[(\sqrt{E_L E_T})_o t_o^3 + (\sqrt{E_L E_T})_i t_i^3] [(\sqrt{E_L E_T})_o t_o + (\sqrt{E_L E_T})_i t_i] K_{MO}}{12 h^2 t_o t_i (\sqrt{E_L E_T})_o (\sqrt{E_L E_T})_i} \quad (5)$$

- c. Determine K_m from Figures 5-8 to 5-21 (reference 9),
- d. Calculate K

$$K = K_M + K_F$$

This procedure is used to obtain a K for clamped edges and a K for simply supported edges. There the factor ϕ to be used in equation (4) for clamped edges is

$$\phi = \frac{K_{\text{clamped}}}{K_{\text{simply supported}}}$$

Shear Buckling Load, N_{xy} -

$$N_{xy} = \bar{N}_{xy} + (N_{xy})_{\text{cyl}} \tag{6}$$

The shearing buckling load of the cylindrical panel is the sum of the cylinder shear buckling load and the shear buckling load of a flat panel, reference 10. Therefore, $(N_{xy})_{\text{cyl}}$ is calculated from equation (2). N_{xy} is calculated from section 6 of reference 9, as follows:

- a. Determine K_m and K_{m0} from Figures 6-7 to 6-14 (reference 9).
- b. Calculate K_F from equation (5)
- c. $K = K_F + K_m$
- d. $\bar{N}_{xy} = K \frac{\pi^2}{b^2} D_1$

where b is the length of the short edge. Linear interaction was assumed between shear and axial load buckling.

In addition to the general instability modes discussed above, the sandwich design must be able to resist local buckling in the form of intercell buckling and face wrinkling.

Intercell Buckling -

$$\bar{\sigma}_f = .764 \sqrt{E_L E_T} \left(\frac{t_f}{d} \right)^{3/2} \tag{7}$$

This is based on reference (11), and

- $\bar{\sigma}_f$ = face buckling stress
- d = cell diameter

Face Wrinkling -

For thin cores the following equations, taken from reference 12, account for initial waviness of the sandwich faces:

$$\sigma_{cr} = \gamma \left[.590 (E_L E_C t_c)^{1/2} + .386 G_{xz} t_c / t_f \right] \quad (8)$$

γ is the waviness correction factor and is defined as

$$\gamma = \frac{1}{1 + c\beta}$$

where

$$c = \frac{\pi G_{xz}}{\lambda_{cr}}$$

$$\lambda_{cr} = 1.670 t_f (E_L t_c / E_L t_f)^{1/4}$$

$$\beta = 6.3 \times 10^{-6}$$

and

t_c = core thickness

t_f = face thickness

E_c = core modulus in thickness direction

σ_{cr} = face wrinkling stress

Analysis

The configuration and design of the composite fuselage has been described previously. This design was analyzed for buckling using the methodology just presented. The key geometric parameters for this analysis are as follows:

Outer face thickness - .66 mm (.026")

Inner face thickness - .41 mm (.016")

Core thickness - 64 mm (1/4")

h = 6.88 mm (.27")

r = 31.75 cm (12.5")

Panel length, $L = 104.1 \text{ cm (41")}$

Panel width = 33.0 cm (13")

Material properties are given in Table 5-2. The core properties are as follows:

$$G_{XZ} = 310 \text{ GPa (45000 psi)}$$

$$G_{YZ} = 152 \text{ GPa (22000 psi)}$$

$$E_C = 531 \text{ GPa (77000 psi)}$$

From these values

$$\left(\sqrt{E_L E_T} \right)_o = 25.7 \text{ GPa (} 3.7 \times 10^6 \text{ psi)}$$

$$\left(\sqrt{E_L E_T} \right)_i = 31.0 \text{ GPa (} 4.5 \times 10^6 \text{ psi)}$$

$$\left(\sqrt{E_L E_T} \right)_o t_o = 16.96 \text{ MN/m (96200 \#/in.)}$$

$$\left(\sqrt{E_L E_T} \right)_i t_i = 12.61 \text{ MN/m (72000 \#/in.)}$$

$$D_l = 362.8 \text{ Nm (3211 in. lb.)}$$

$$D_q = 2.31 \text{ MN/m (13185\#/in.)}$$

and the critical buckling loads are

$$N_x = 350 \text{ kN/m (2000 \#/in.)} \quad \text{simply-supported edges}$$

$$N_{xy} = 271 \text{ kN/m (1550 \#/in.)}$$

$$N_x = 665 \text{ kN/m (3800 \#/in.)} \quad \text{clamped edges}$$

$$N_{xy} = 394 \text{ kN/m (2250 \#/in.)}$$

For conservatism, the simply supported results were used. The local buckling mode stresses are

$$\sigma_f = 1085 \text{ MPa (157.4 KSI)} \quad \text{inner face intercell buckling}$$

$$\sigma_f = 1849 \text{ MPa (268.2 KSI)} \quad \text{outer face intercell buckling}$$

and

$$\sigma_{cr} = 471 \text{ MPa (68.3 KSI)} \quad \text{inner face wrinkling}$$

$$\sigma_{cr} = 355.1 \text{ MPa (51.5 KSI)} \quad \text{outer face wrinkling}$$

The corresponding load on the sandwich to cause these wrinkling stresses in the faces are

$$\begin{aligned} N_x &= 406 \text{ kN/m (2320 \#/in.)} && \text{inner face} \\ N_x &= 441 \text{ kN/m (2520 \#/in.)} && \text{outer face} \end{aligned}$$

These results are shown in summary form in Table 5-5.

5.6 STRENGTH AND MARGINS OF SAFETY

The overall strength of the composite fuselage panels is based on the results of the NASTRAN finite element analysis, the buckling analysis and the material properties. NASTRAN stresses and material allowable stresses were converted into equivalent axial and shear loads per unit length, N_x and N_{xz} , by apportioning the load to the two faces according to the ratio of their stiffnesses. The outer face takes 53% of the in-plane compression and 60% of the in-plane shear, while the inner face takes the remainder. The stress to load conversions, therefore, are as follows:

	<u>SI</u>	<u>English</u>
$N_{x_{of}}$	$= 1.25 \sigma_{x_{of}}$	$= .049 \sigma_{x_{of}}$
$N_{x_{if}}$	$= .87 \sigma_{x_{if}}$	$= .034 \sigma_{x_{if}}$
$N_{xy_{of}}$	$= 1.10 \sigma_{xy_{of}}$	$= .043 \sigma_{xy_{of}}$
$N_{xy_{if}}$	$= 1.03 \sigma_{xy_{if}}$	$= .040 \sigma_{xy_{if}}$
	N - kN/m	N - #/in.
	σ - MPa	σ - psi

Stresses at critical points from the NASTRAN analysis were converted into loads and plotted as on applied load envelope, Figure 5-20. The buckling capability is shown as a straight line interaction between axial load and shear. In addition, the loads which would produce face wrinkling and compression and shear failure in the faces are shown. The resulting strength envelope is one which is dominated by buckling and facing shear strength capabilities, although the minimum margin region is in the area of the intersection of the buckling and inner face compression strengths. The margin of safety in this region is .4.

Figure 5-21, which shows a similar comparison of loads and strength for the reinforced sections where both faces are 4 plies thick, is included for reference without the detail calculations. The margins of safety for this are greater than for those represented by Figure 5-20, and so the thinner sandwich sections are more critical.

TABLE 5-5SUMMARY OF SANDWICH PANEL BUCKLING CAPABILITY

	N_x		N_{xy}	
	<u>KN/M</u>	<u>#/in.</u>	<u>KN/M</u>	<u>#/in.</u>
Simple Supports	350	2000	271	1550
Clamped	665	3800	394	2250
Face Wrinkling	406	2320		
Intercell Buckling		High		

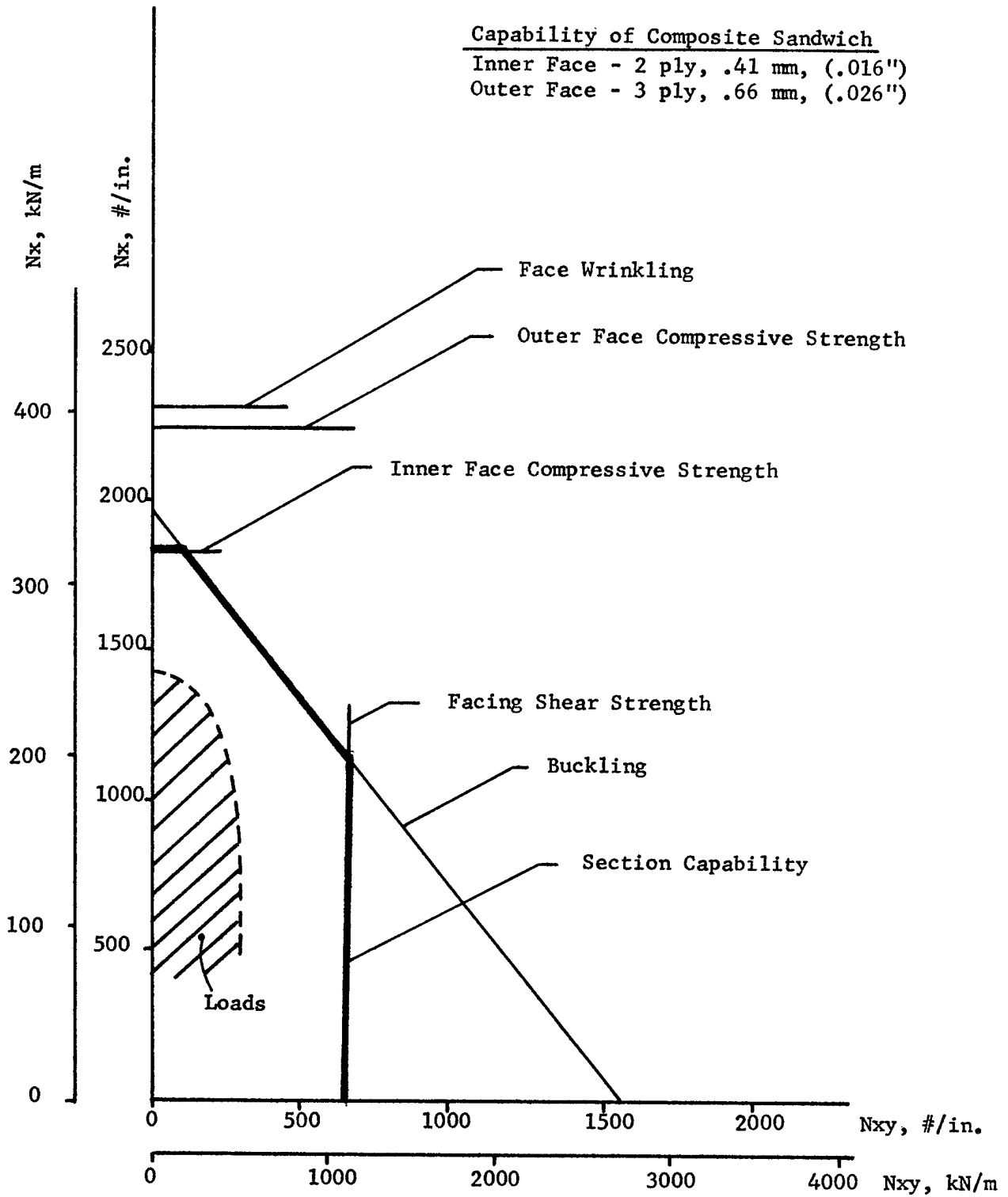

Figure 5-20. Strength of Composite Fuselage Panels, Basic Section

Capability of Composite Sandwich
Both Faces - 4 ply, .81 mm, (.032")

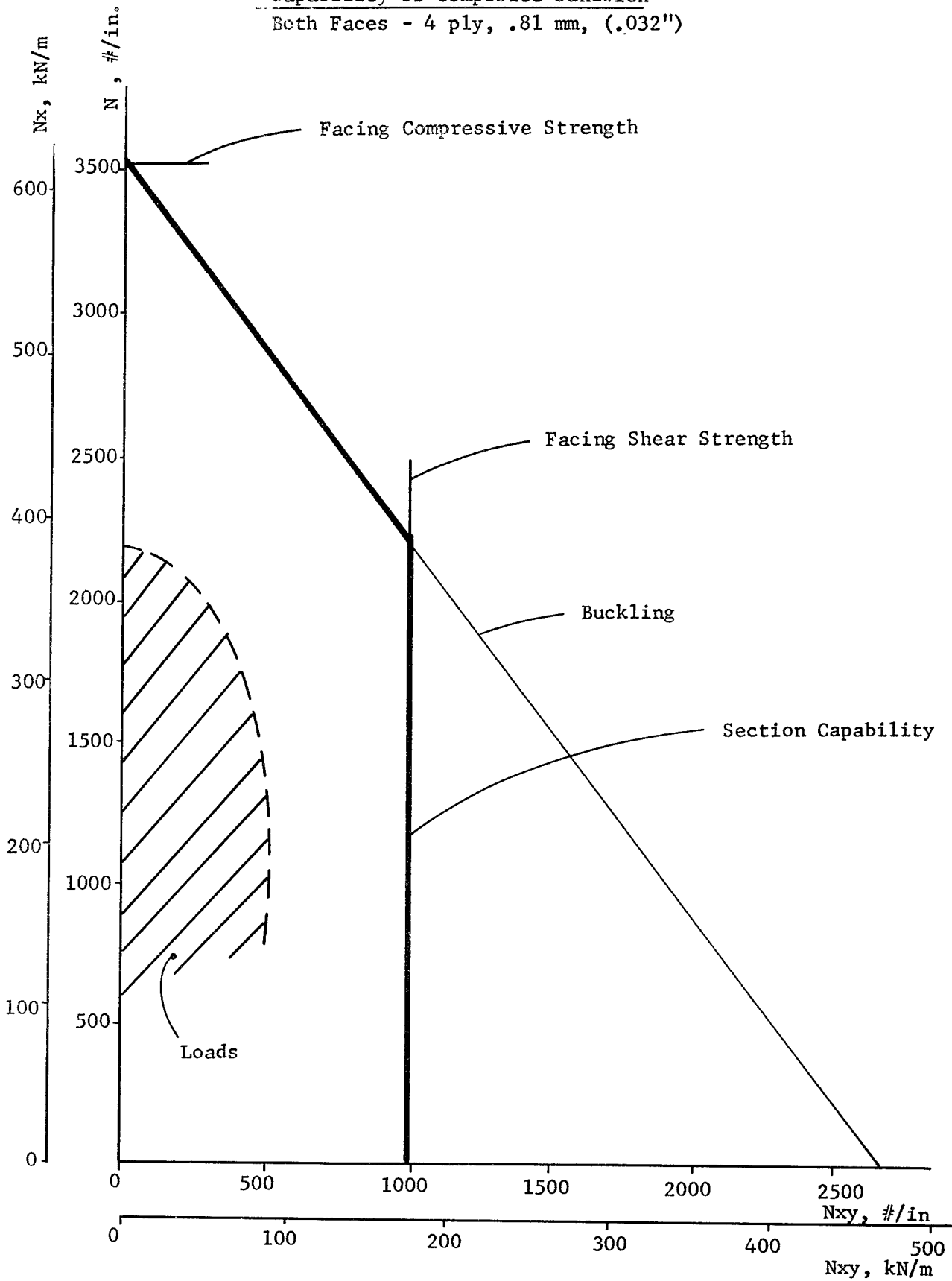

Figure 5-21. Strength of Composite Fuselage Panels - Reinforced Section

6.0

ELEMENT TESTS

One of the areas of concern early in the design phase was the strength of the closeout section of the fuselage panels. The closeout is formed by tapering the core and bringing the two faces together, with added plies for reinforcement. In order to evaluate this design, a set of specimens was tested under compressive loading. The configuration of these specimens is shown in Figure 6-1. The goal was to show that the closeout was at least as strong as the main panel area.

Four specimens were tested in the setup shown in Figure 6-3. A lateral support was used to simulate the support conditions in the cylindrical shell configuration. Results of these tests are given in Table 6-1. The failure loads are greater than the design loads, but more important than load magnitudes is the fact that none of the specimens failed in the closeout area. This gave assurance that the closeout design was adequate and would not cause premature failures in that area. A photograph of the failed specimens is given in Figure 6-3.

7.0 SUBCOMPONENT DESIGN AND TEST

7.1 DESIGN

In order to substantiate the basic fuselage panel design and its method of attachment to the existing metal bulkheads, a cylinder was designed and fabricated for testing. This shell had the same honeycomb sandwich design as the fuselage panels, and was the same radius and length. It was, however, a complete cylinder rather than a cylindrical panel, Figure 7-1. The complete cylinder is easier to test and, in many respects, easier to make than the panel, hence, its selection as a subcomponent test article. Figure 7-2 gives the design details of this cylinder.

The cylinder is 63.5 cm (25 in.) OD and 104.1 (41 in.) long. It was made in two halves and joined by two longitudinal splices. The splices are honeycomb sandwich plates bonded between the two faces of the main shell sandwich.

7.2 TEST CONDITIONS AND FIXTURES

Two sets of tests were performed on the cylinder to demonstrate the overall structural adequacy of the design to withstand critical flight loads. The first was a compression test to limit load, since the fuselage design is critical in compression. The second set of tests was a series of tension tests performed to demonstrate the ability of the crack arrester strips to stop a crack, and therefore, render the composite design fail-safe.

The test fixture configuration for testing the cylinder in compression and tension is schematically illustrated in Figure 7-3. Compressive and tensile loading was introduced into the cylinder through a pair of concentric aluminum end rings, the inner ring being both bonded (EA 9309) and bolted to

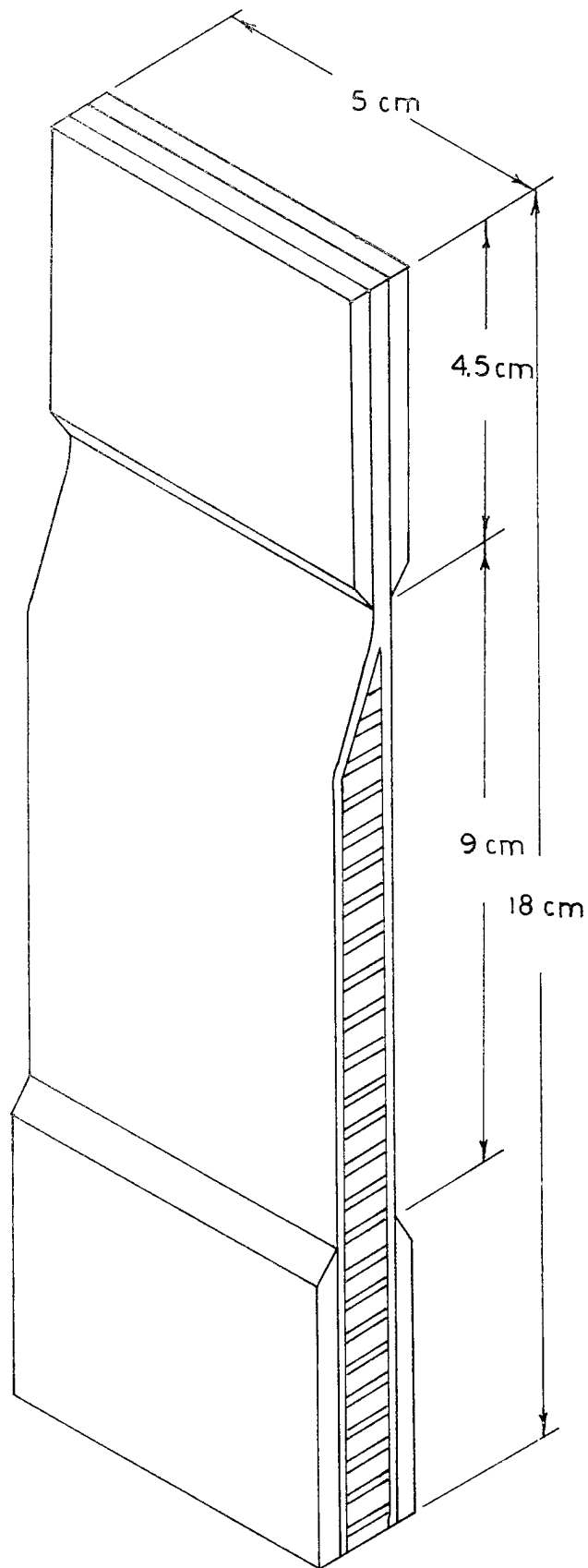

Figure 6-1. Closeout Specimen Configuration

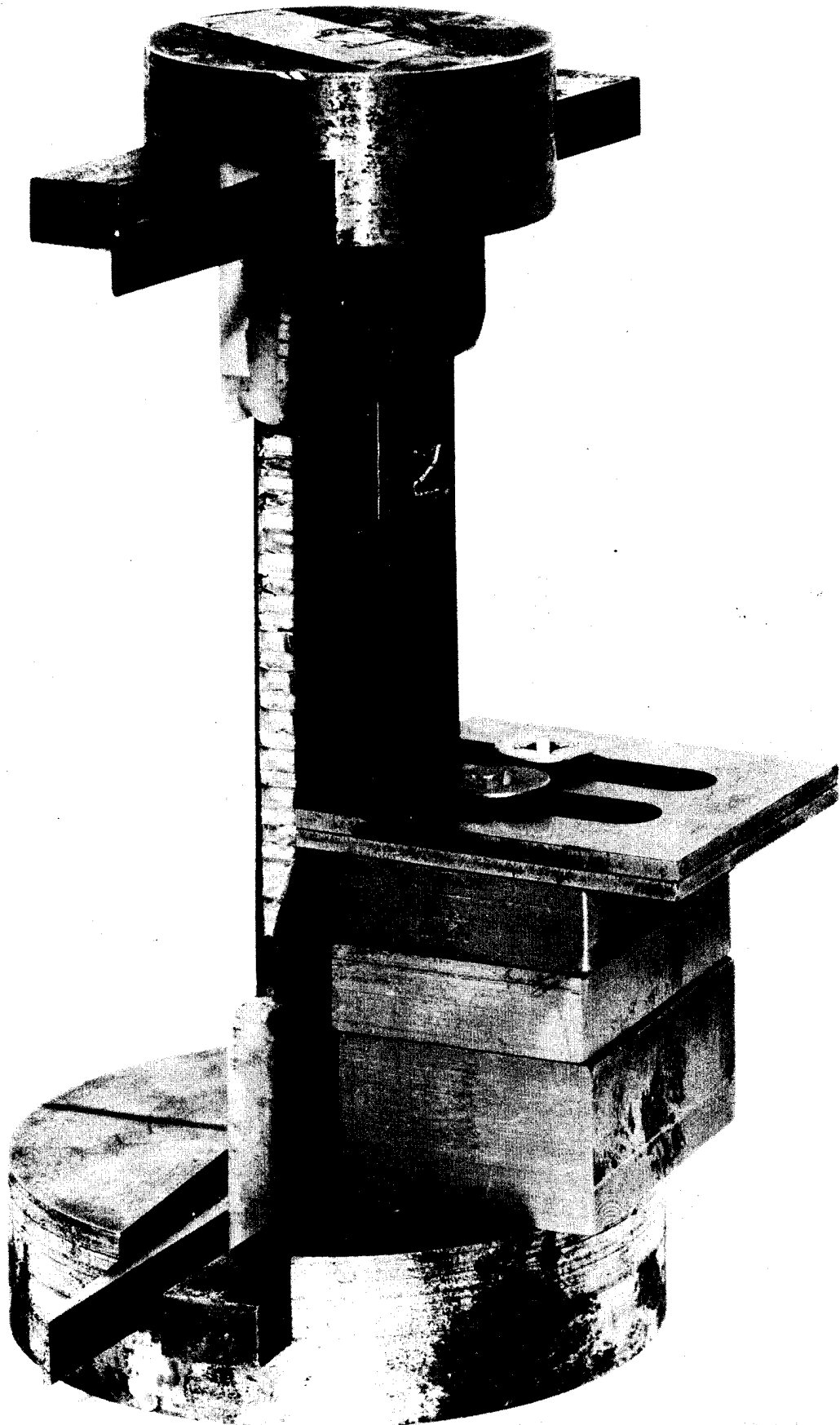

Figure 6-2. Closeout Specimen Test Setup

TABLE 6-1RESULTS OF CLOSE-OUT SECTION TESTS

<u>SPECIMEN</u>	<u>FAILURE LOAD</u>	<u>FAILURE MODE</u>
1	13678 N(3075#)	Inner Face Crimping-Near Tab
2	13388 N(3010#)	Excessive Lateral Deflection
3	12343 N(2775#)	Gross Section Shear
4	11609 N(2610#)	Gross Section Shear

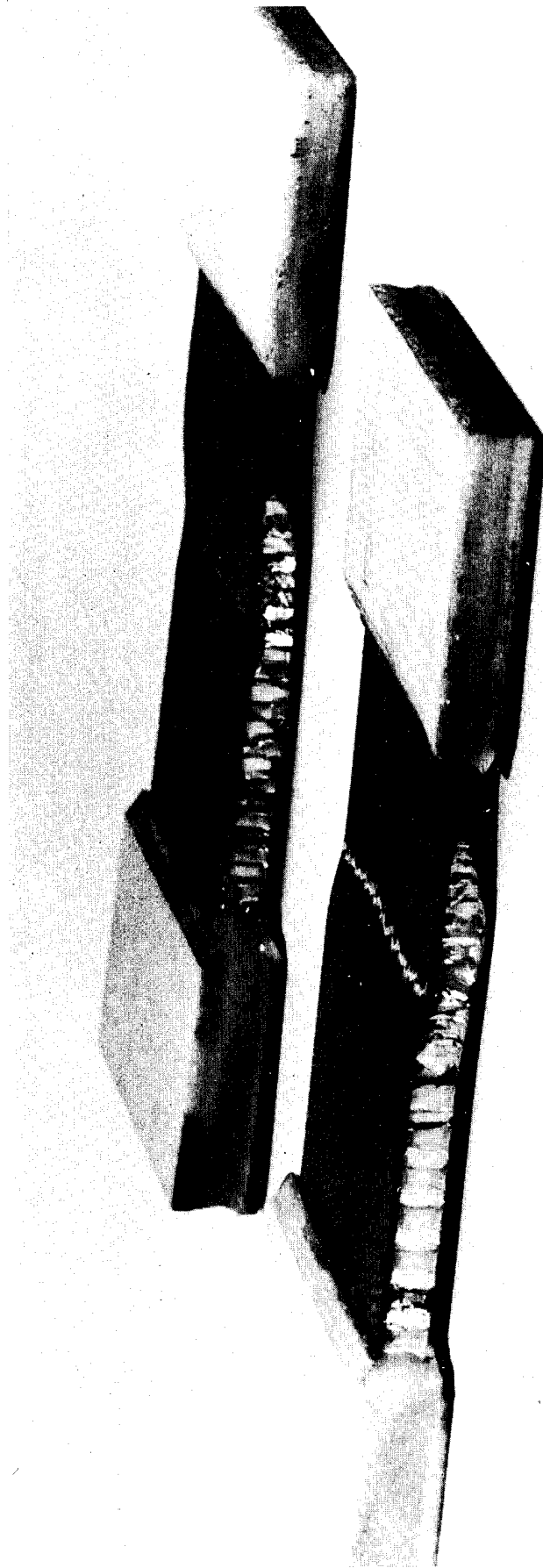

Figure 6-3. Failed Closeout Specimens

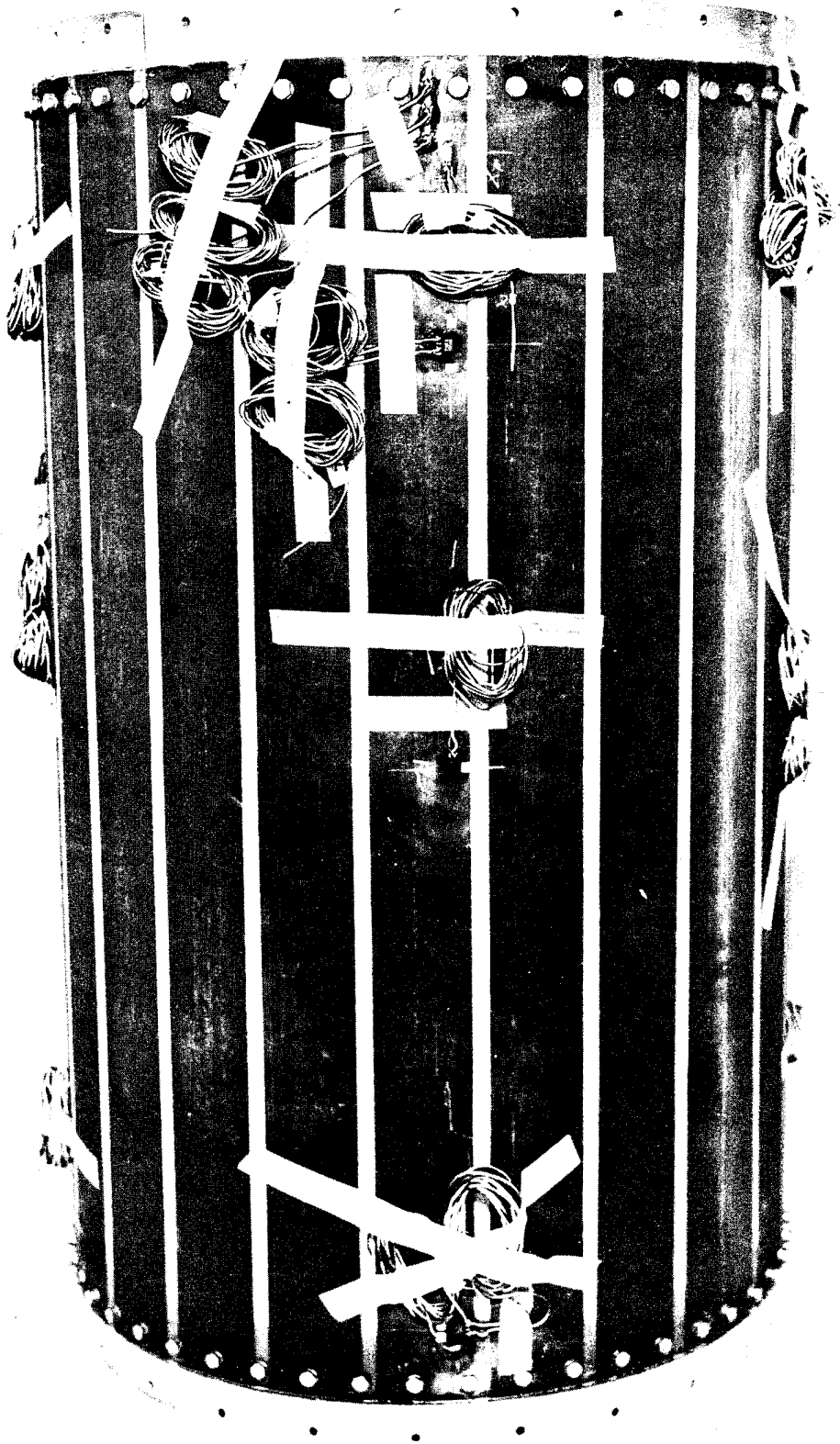

Figure 7-1. Cylinder Subcomponent

NADC-77149-30

DWG. "BQM-34E CYLINDER TEST SPECIMEN" WILL BE FOUND IN THE BACK
OF THIS REPORT

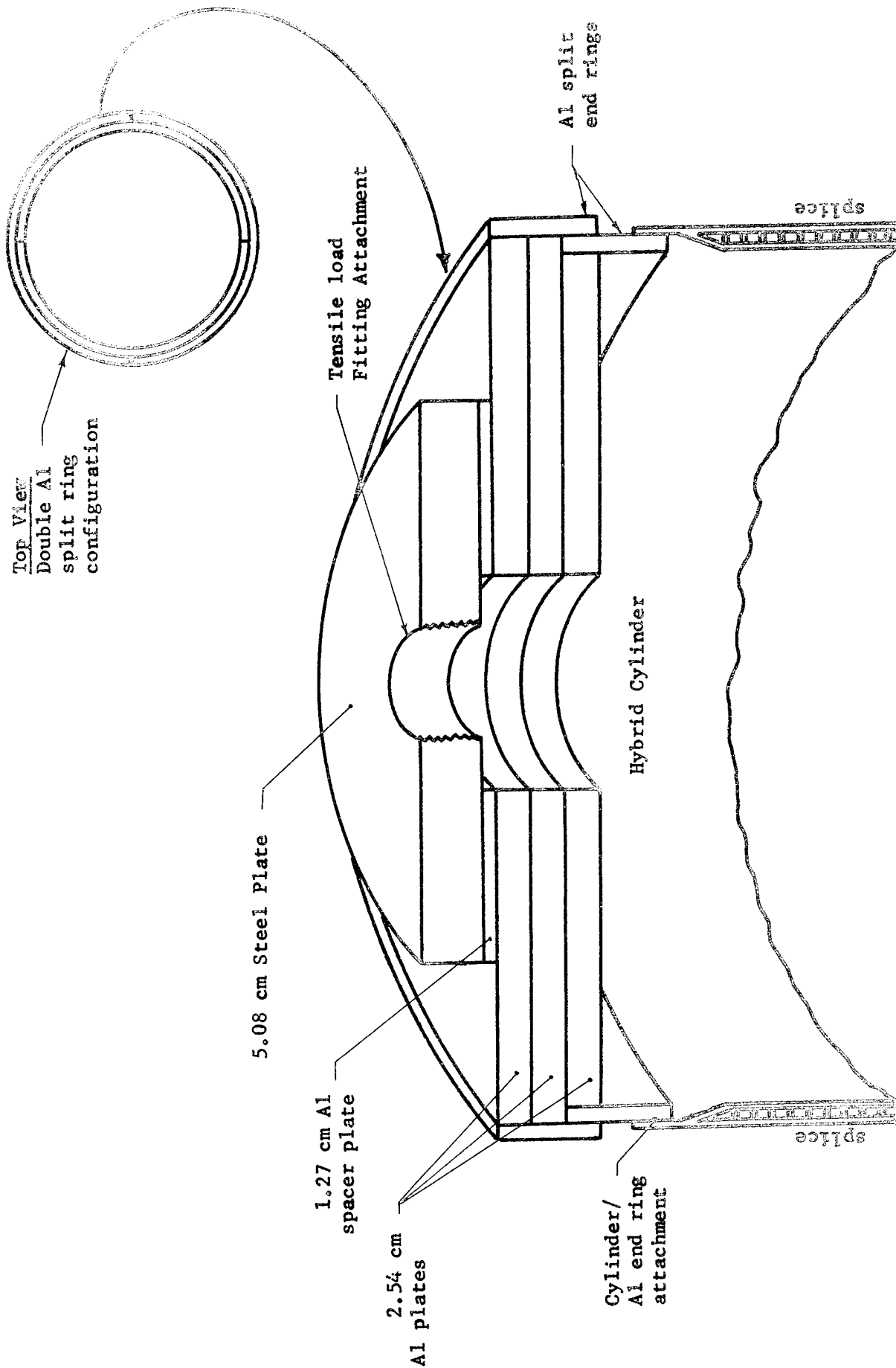

Figure 7-3. Cylinder Test Fixtures

the reinforced solid laminate areas at both ends of the cylinder. The inner and outer end rings were bolted together and in turn bolted to three 2.54 cm (1 in.) thick circular aluminum plates which fit inside the concentric rings. The three circular aluminum plates and an additional 5.08 cm (2 in.) thick steel circular plate were bolted together to form a single unit in order to react the substantial bending moment induced by the centrally applied load. In compression, the load was applied directly through the top steel plate. In tension, load was introduced into the cylinder through a 7.62 cm (3 in.) diameter fitting which is threaded into the center hole in the steel circular plate. The steel plate is repositioned internal to the three aluminum plates for tensile loading.

7.3 INSTRUMENTATION

Instrumentation for the tests consisted of strain gages and deflection gages. Figure 7-4 and Table 7-1 show the locations of the strain gages. There were 6 biaxial gages and 32 uniaxial gages giving a total of 34 strain readings. Eight of the gages were on the inner face and the remainder on the outside face.

Four deflection gages spaced 90° apart were used to measure axial deflection in both the compression and tension tests. For the compression test four more gages were used, also spaced 90° apart, to measure lateral deformation of the cylinder at its mid-length. These are shown in Figure 7-5.

Strains were recorded on the portable B & W recorder. Deflections were measured using LVDT's.

7.4 HYBRID COMPOSITE TESTING

The cylinder tests were performed in the 1334 KN (300,000 pound) capacity test machine. Figure 7-6 shows the composite sandwich cylinder in the testing machine. The first two tests performed were compression tests to 50% and 100% of limit load, 186.8 Kn (42000 lb.) and 373.6 Kn (84000 lb.) respectively. The cylinder withstood these loads successfully, and no unusual behavior was observed. This was the basic demonstration of the ability of the design to take critical flight loads.

A second, and more comprehensive, series of tests was then performed to evaluate the crack arrestment design. First, proof tests were run at 50%, 75%, and 100% of design ultimate load as a demonstration of basic tensile strength. Then five additional tests were run with induced damage, as depicted in the tensile test setup as shown in Figure 7-7. For test 2, a 2.54 cm (1 in.) sawcut crack was formed midway between two adjacent crack arrester strips. Load was applied until the crack propagated. (See Figure 7-8.) This occurred at 120% of design limit load (DLL). Propagation in this hybrid material was not at all sudden. The crack started to propagate at a particular load and continued to propagate gradually as the load was increased, until it reached the arrester strip. The propagation loads given here represent the load when the crack reached the arrester strip. Test 3 was a repeat of test 2 with identical results.

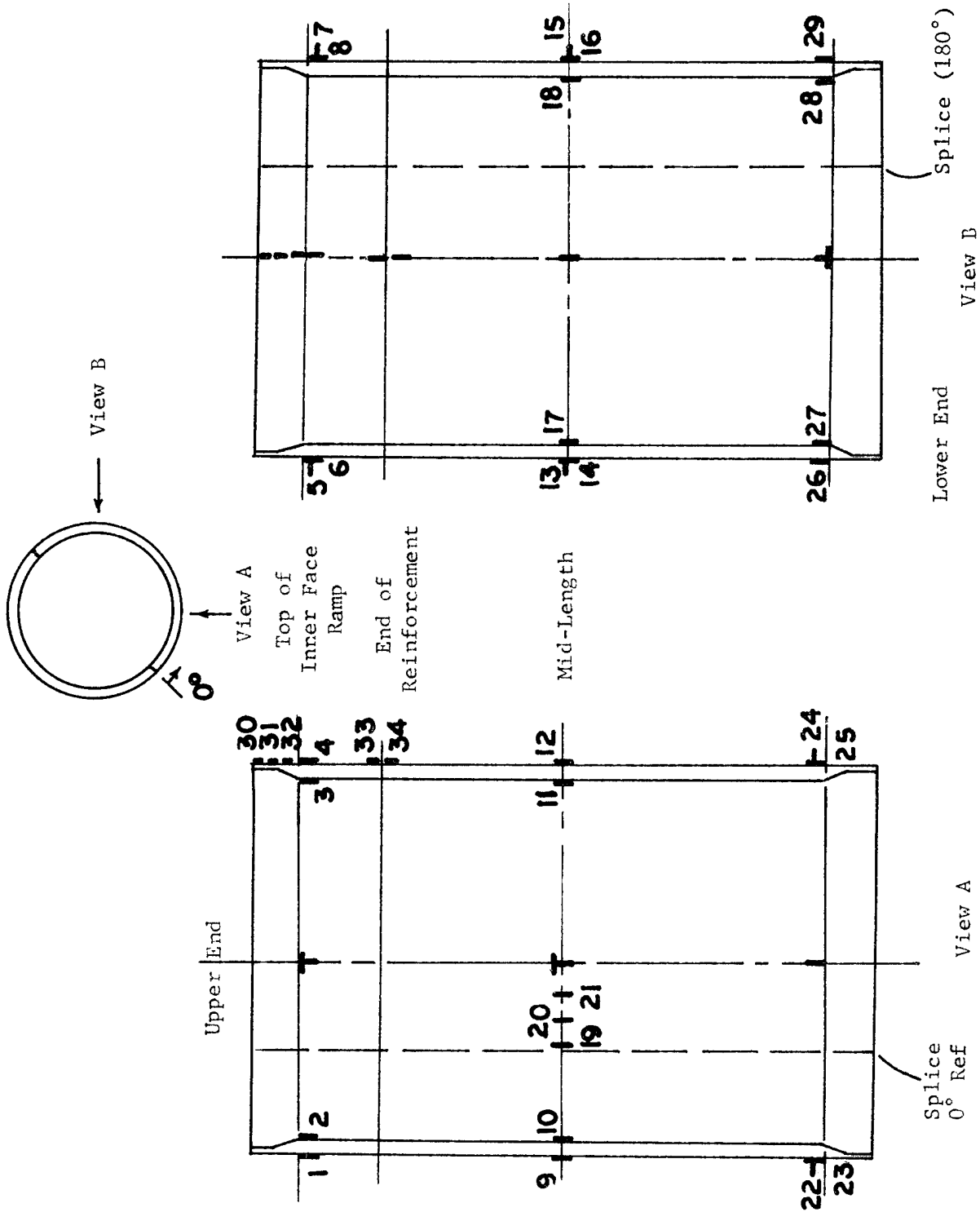

Figure 7-4. Cylinder Strain Gage Locations

TABLE 7-1
STRAIN GAGE LOCATIONS

<u>GAGE NO.</u>	<u>FACE</u>	<u>AXIAL LOCATION</u>	<u>CIRC LOCATION</u>
1	Outer	Upper End	315°
2	Inner	"	315°
3	Inner	"	135°
4	Outer	"	135°
5,6	Outer	"	45°
7,8	"	"	225°
9	"	Mid-Length	315°
10	Inner	"	315°
11	"	"	135°
12	Outer	"	135°
13,14	"	"	45°
15,16	"	"	225°
17	Inner	"	45°
18	"	"	225°
19	Outer	"	0°
20	"	"	15°
21	"	"	30°
22,23	"	Lower End	315°
24,25	"	"	135°
26	"	"	45°
27	Inner	"	45°
28	"	"	225°
29	Outer	"	225°
30	"	Upper End	135°
31	"	"	135°
32	"	"	135°
33	"	8" from Upper End	135°
34	"	"	135°

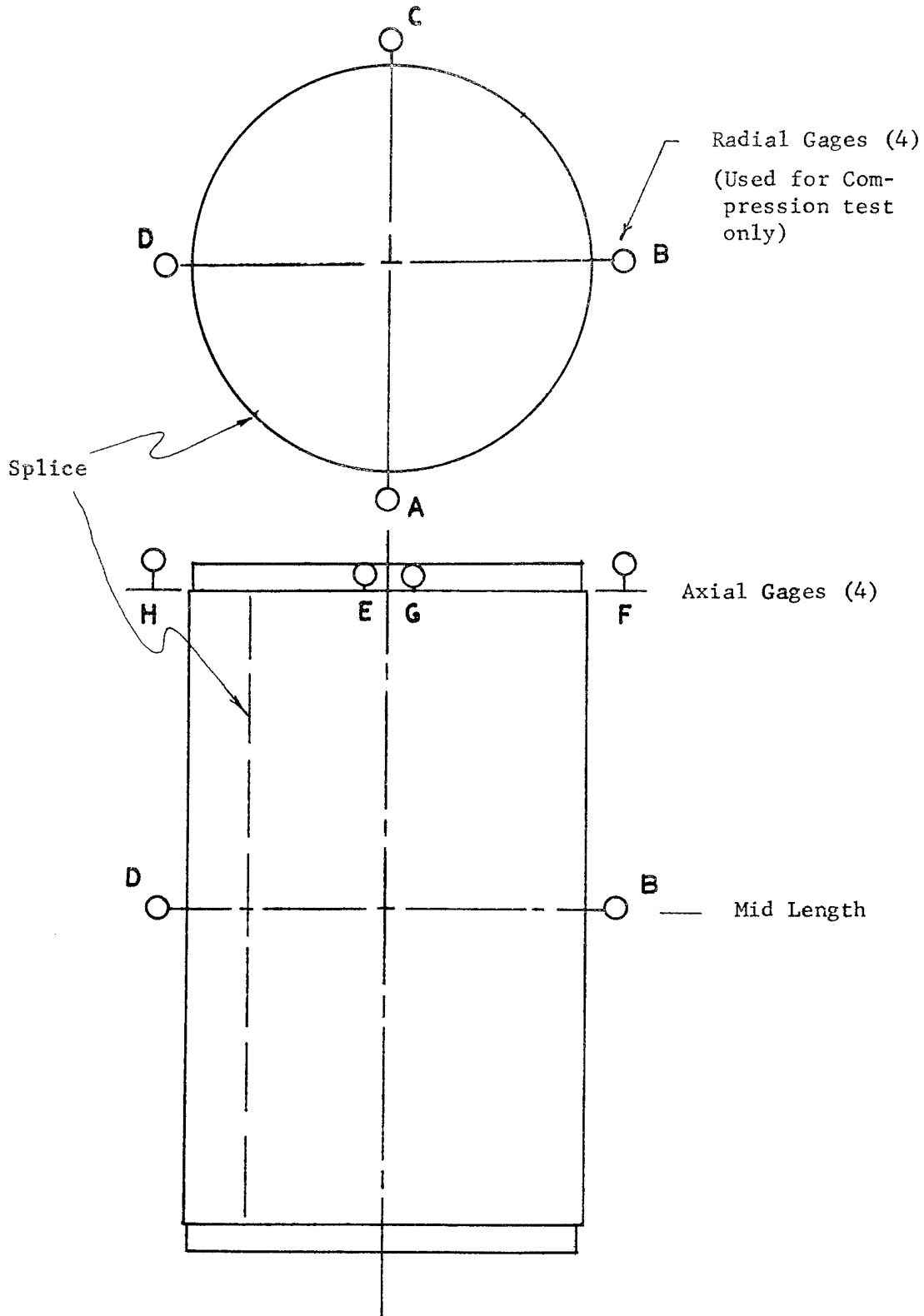

Figure 7-5. Deflection Gage Locations

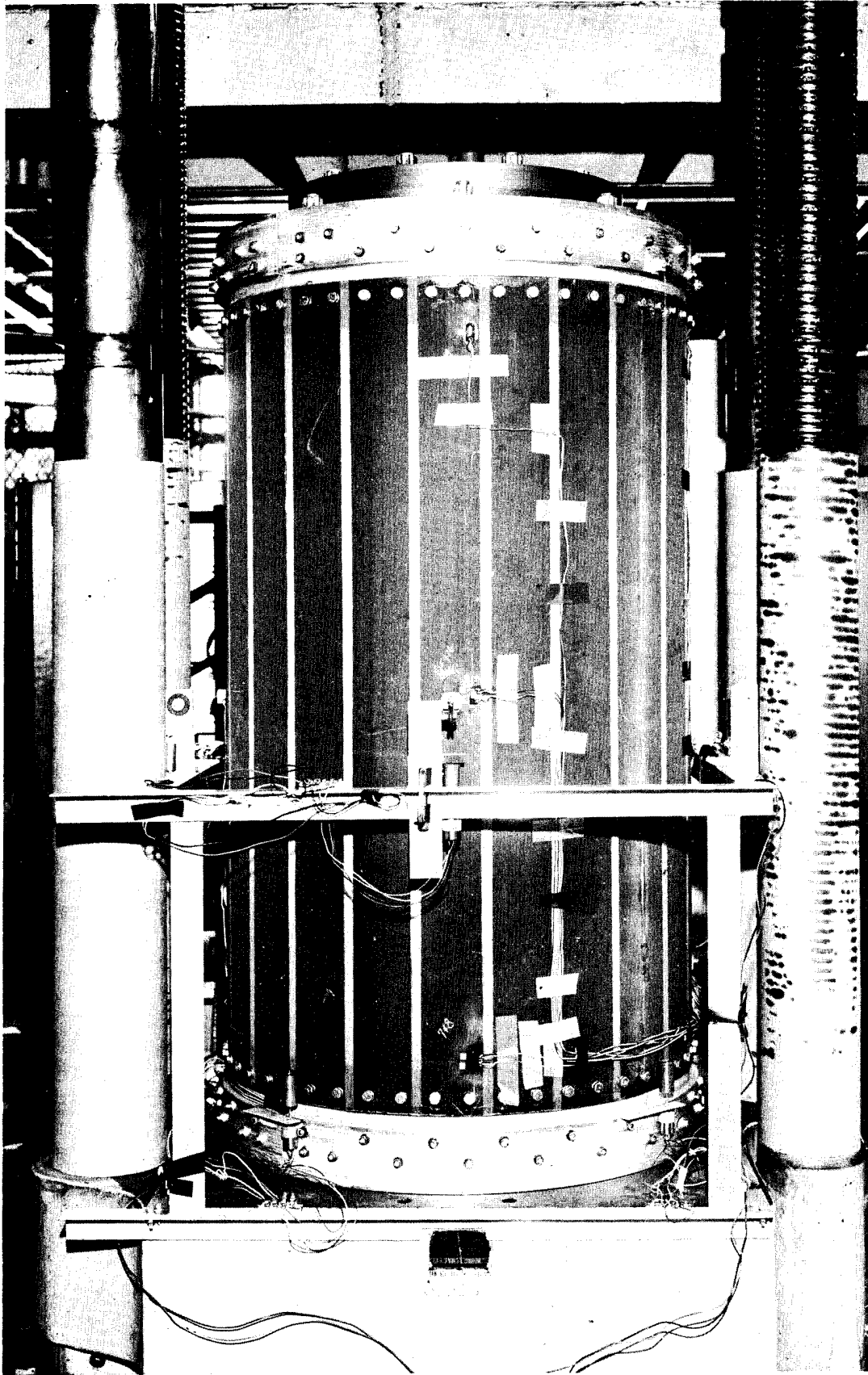

Figure 7-6. Cylinder Subcomponent Compression Test Setup

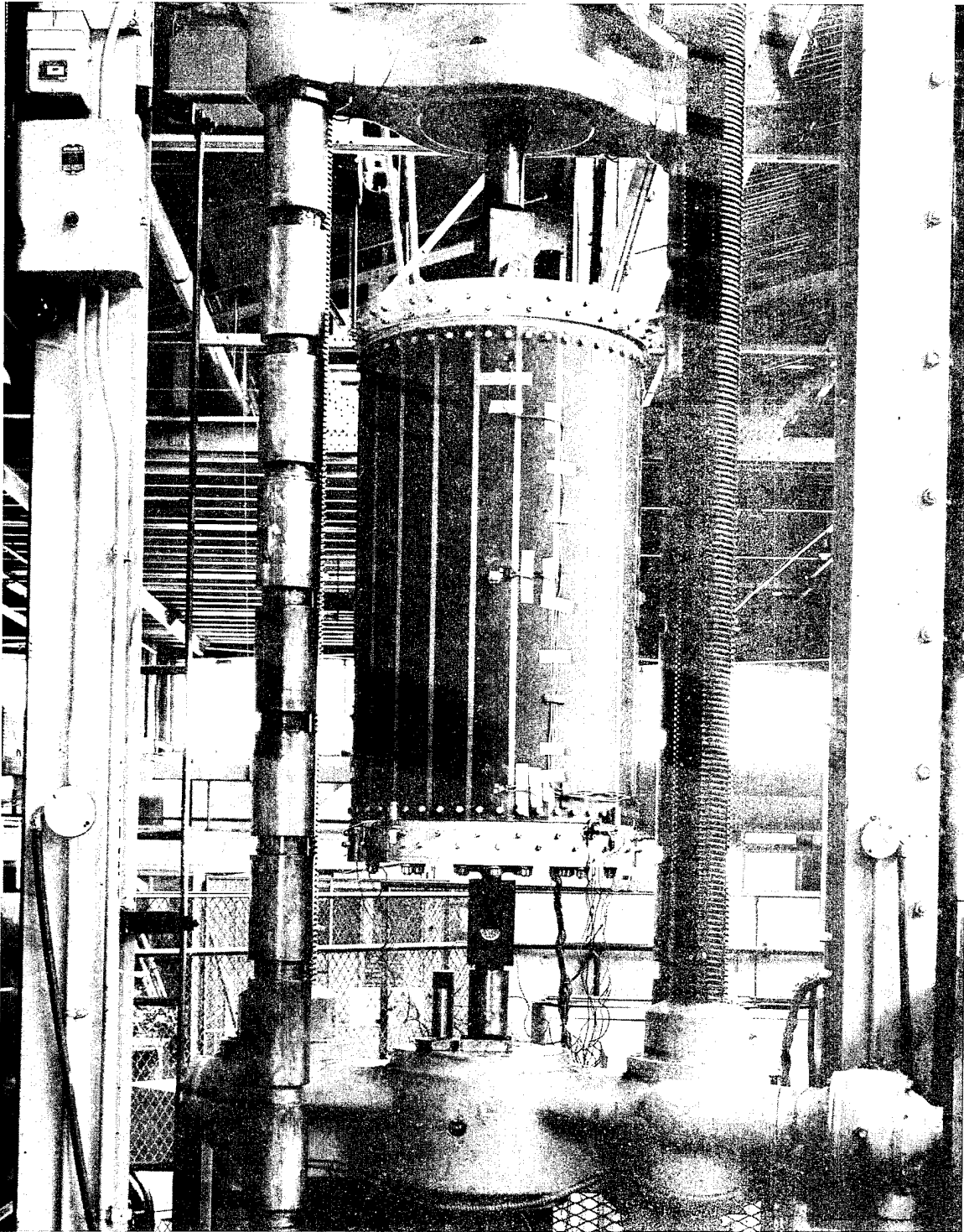
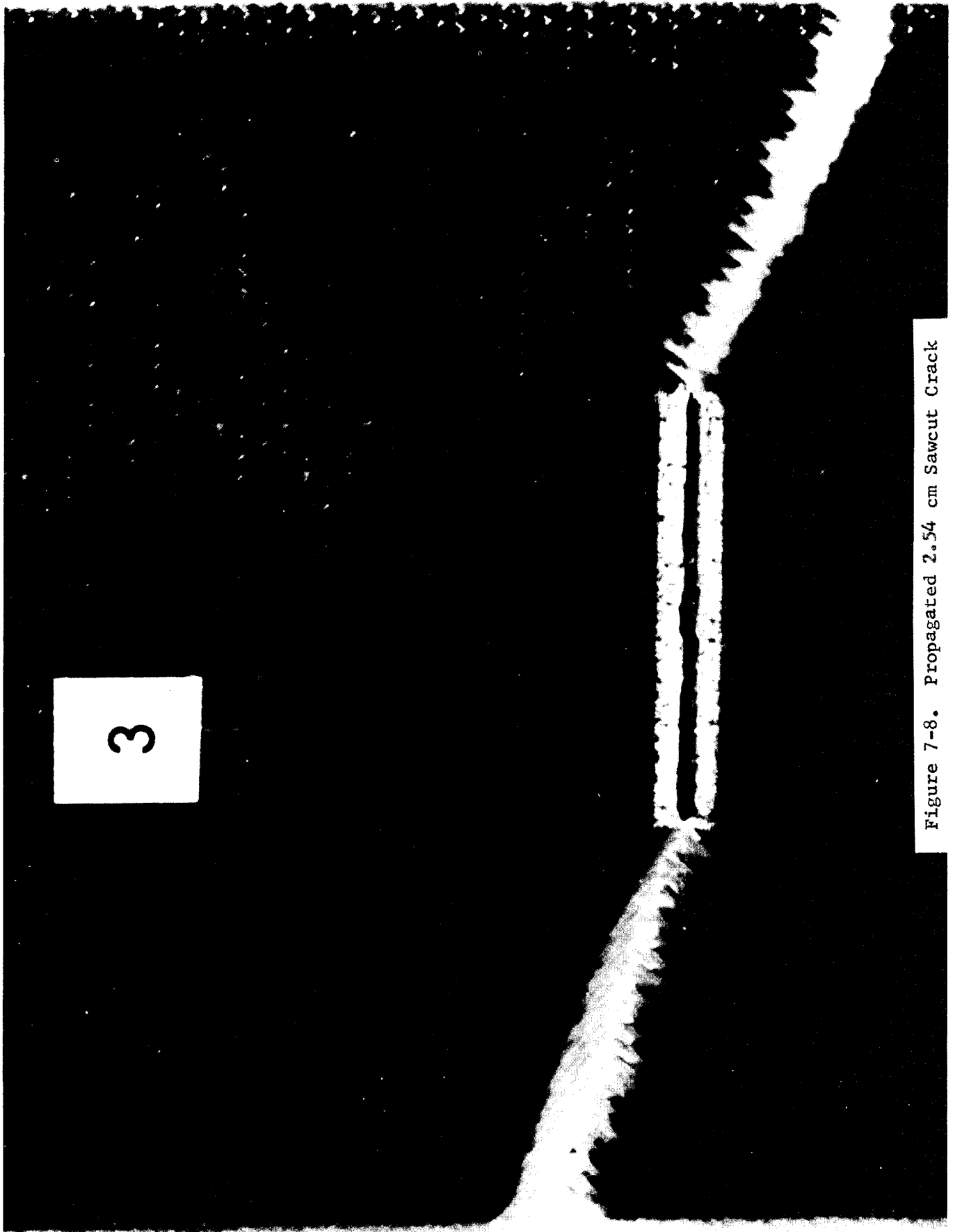

Figure 7-7. Cylinder Subcomponent Tension Test Setup



3

Figure 7-8. Propagated 2.54 cm Sawcut Crack

Tests 4 and 5 were different in two respects. First, the damage was induced ballistically, and secondly, the structure was under a preload when the damage was induced. In test 4, a .95 cm (3/8 in.) projectile was fired into the cylinder. The damage which was produced had a maximum overall dimension of 2.2 cm (7/8 in.). The preload was 50% DLL. At the time of impact the damage did not propagate, but, upon subsequent application of load, propagation occurred at 114% DLL, Figure 7-9. In test 5, a 2.54 cm (1 in.) projectile was fired with 75% DLL preload. Again, the damage did not propagate at time of impact and in this case no subsequent load was applied, Figure 7-10.

The last test was with a 1.59 cm (5/8 in.) sawcut crack. Propagation in this case was at 129% DLL, Figure 7-11. It should be pointed out that at this time, with 129% DLL on the cylinder, six of the twenty-two sections between crack arrester strips were cracked over their 7.62 cm (3 in.) width, so that even with considerable damage the structure still withstood a high level of loading.

Figure 7-12 shows the cylinder after the testing had been completed. The complete set of crack arrestment tests is summarized in Figure 7-13.

In Figure 7-14, both the stress corresponding to the beginning of propagation and the stress, when the crack reached the arrester strips, are shown and compared to a curve drawn from the equations using the hybrid composite fracture data discussed in reference 13. The data agrees reasonably well with the analysis, although it covers only a narrow range of crack sizes.

8.0

F U S E L A G E T E S T I N G

8.1 INSTRUMENTATION

The three hybrid fuselage components were instrumented with a total of eleven axial strain gages and seven strain rosettes according to the layout diagram shown in Figures 8-1, 8-2 and 8-3. Gages internal and external to the fuselage center section are specified. Gage locations were selected to monitor regions of predicted high stress and areas which are buckling critical. Gage placements also checked load transfer in the closeout sections and load symmetry between the left and right fuselage center section panels.

8.2 TEST METHODS AND EQUIPMENT

The entire BQM-34E fuselage was tested in a self-contained test fixture erected from 30 cm (12 in.) wide - flange beams. Loading was accomplished at fuselage frame stations by means of continuous aluminum bands supported on 2 cm (3/4 in.) thick elastomer compression pads, Figure 8-4a. Where obstacles such as the vertical stabilizer prevented use of continuous bands, aluminum straps were bonded to the fuselage with RTV-88 silicone rubber, Figure 8-4b. Separate wiffle tree arrangements, used to test each of the two load conditions, were attached to the fuselage frame loading points. Additional wiffles were used to load the wing in the 5g maneuver test. In both tests, loads were introduced into the structure through a single load point by means

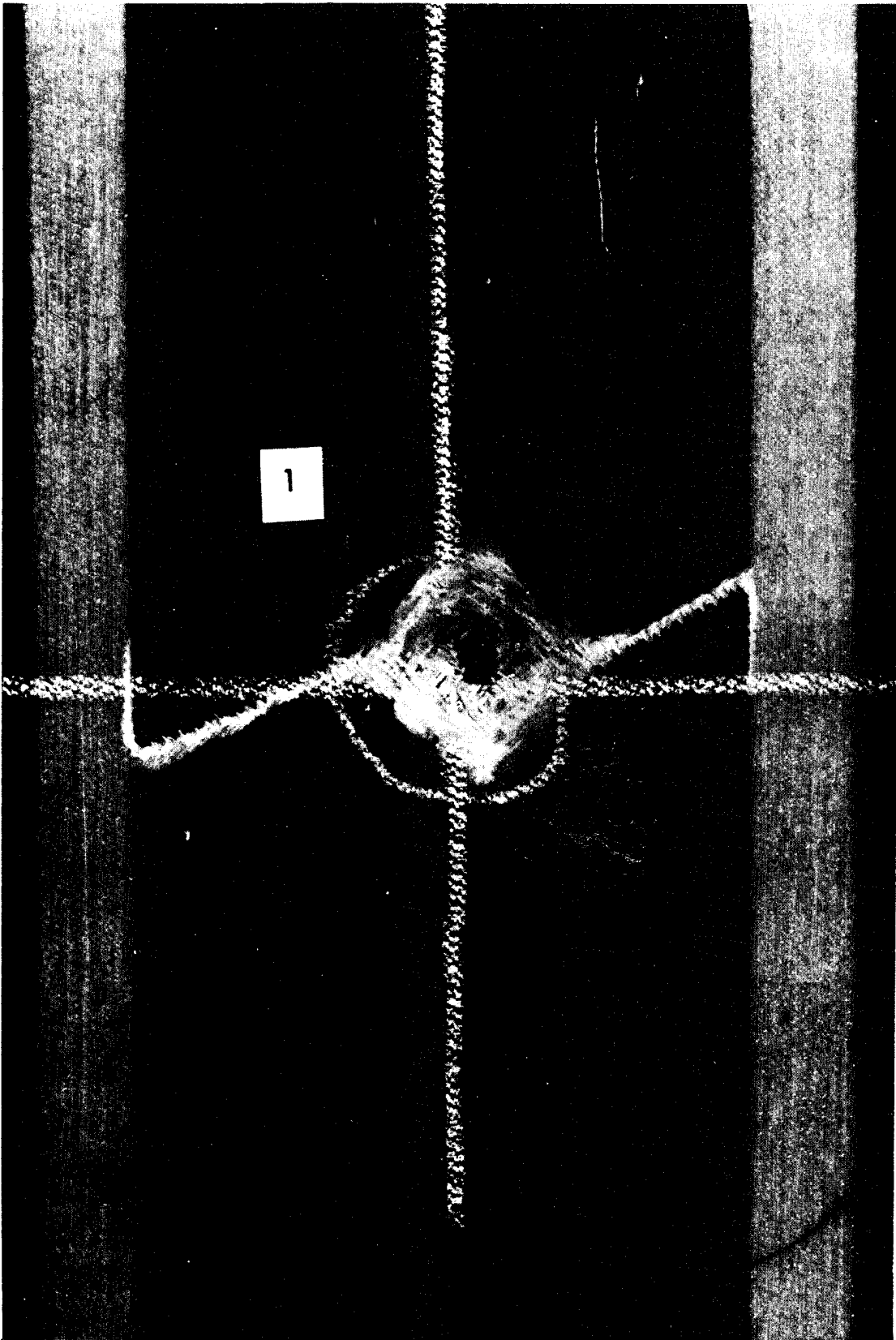

Figure 7-9. Crack Propagation from .95 cm Projectile Damage

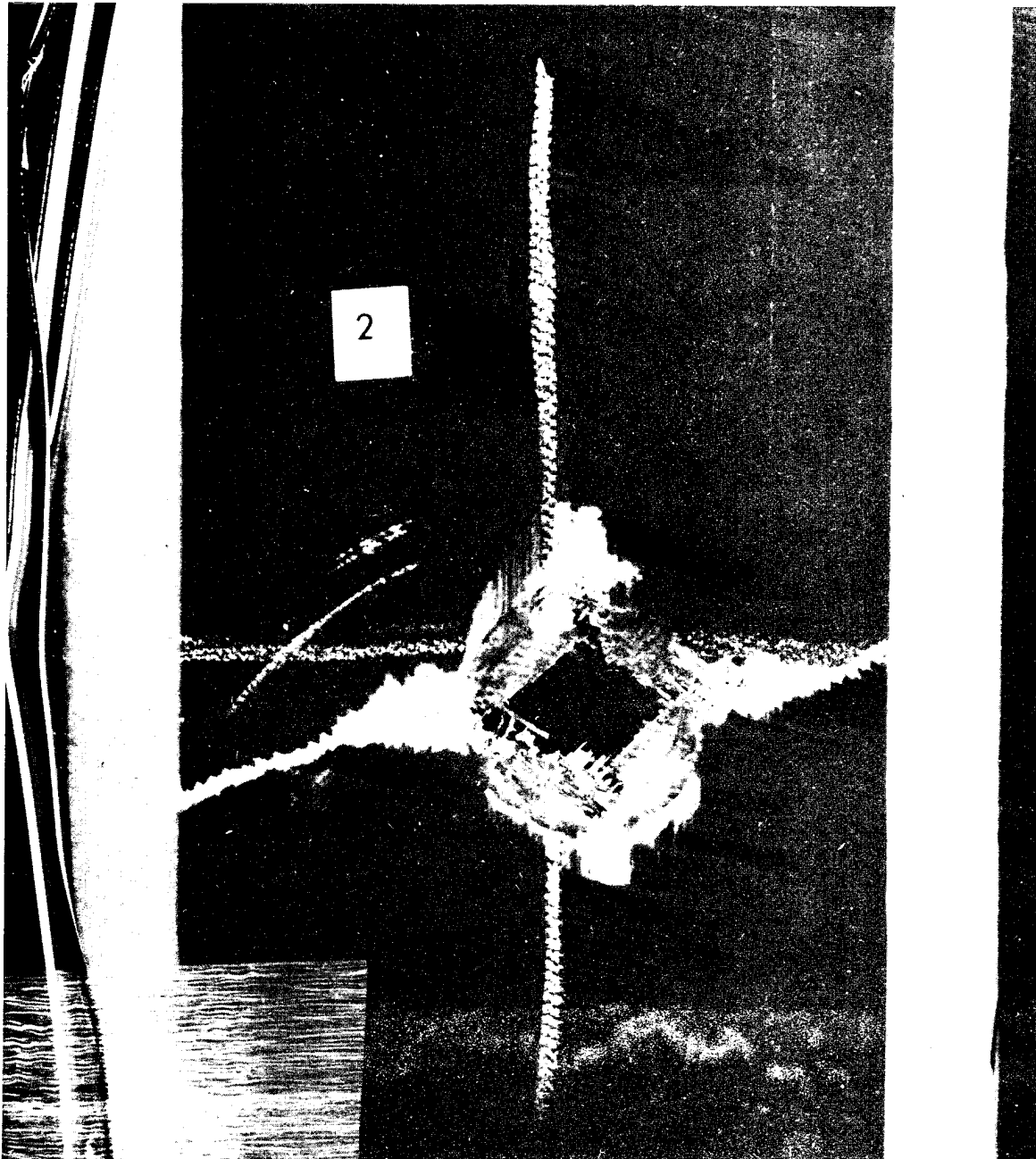

Figure 7-10. Crack Propagation from 2.54 cm Projectile Damage

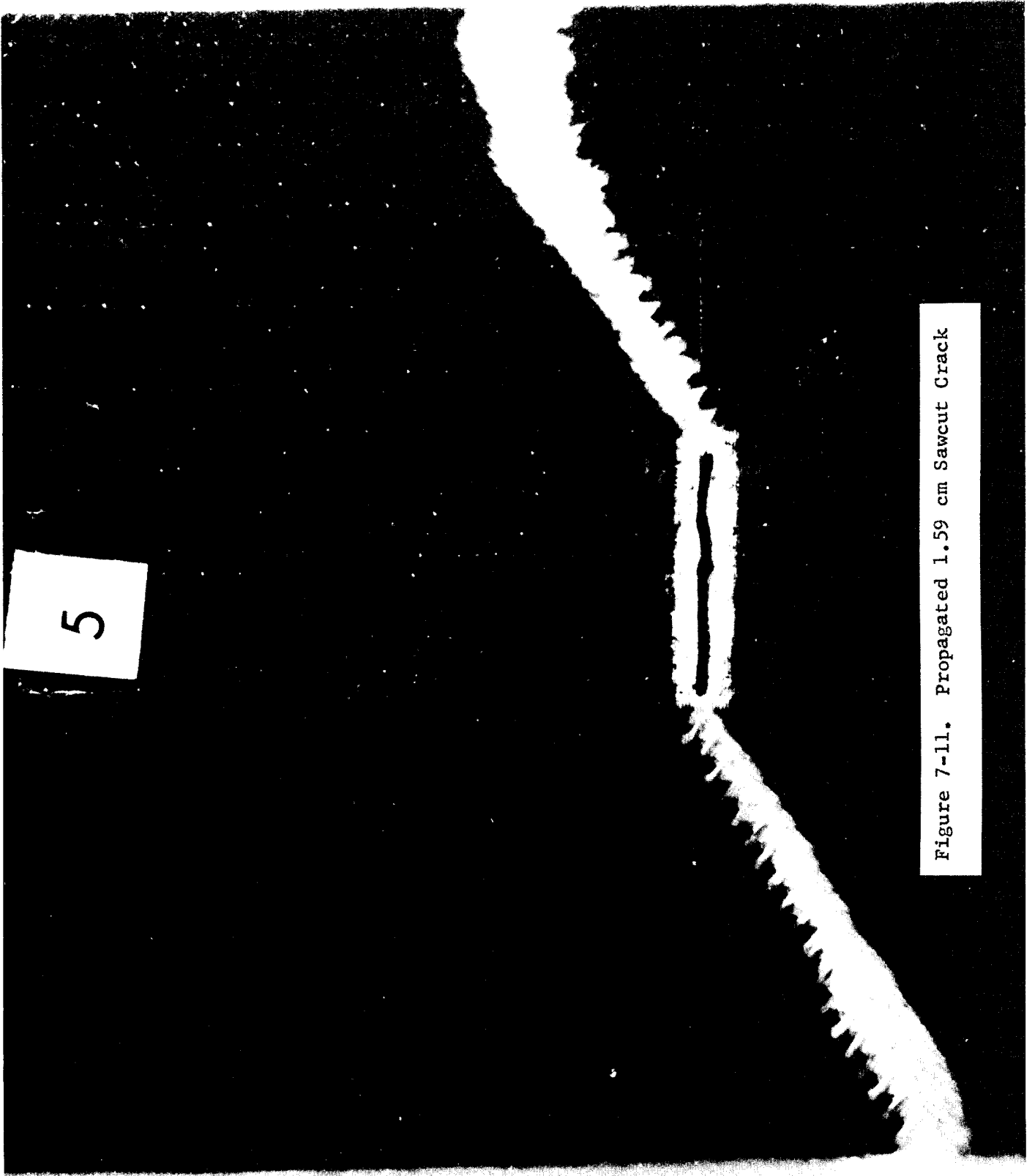

Figure 7-11. Propagated 1.59 cm Sawcut Crack

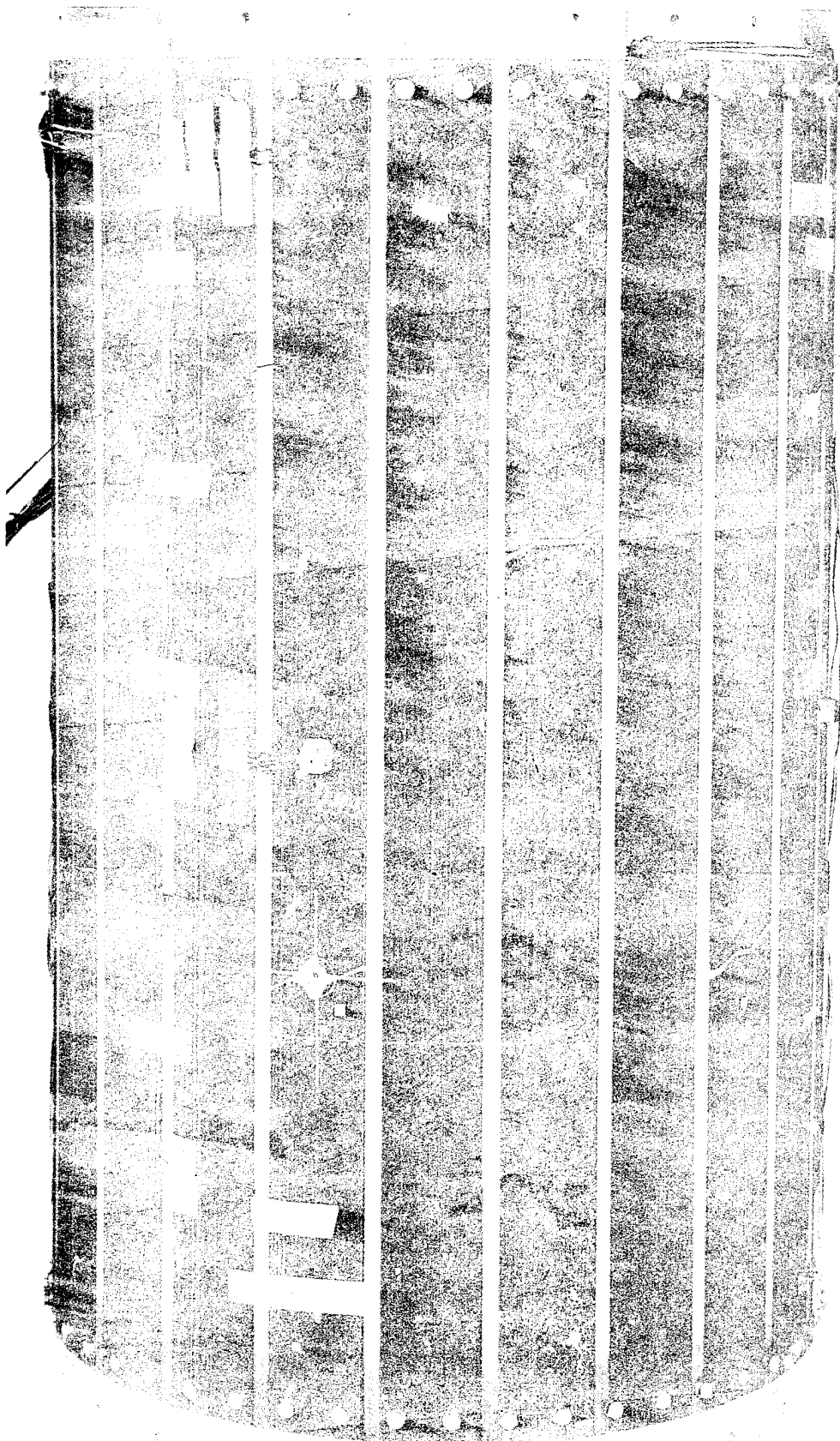

Figure 7-12. Cylinder After Testing

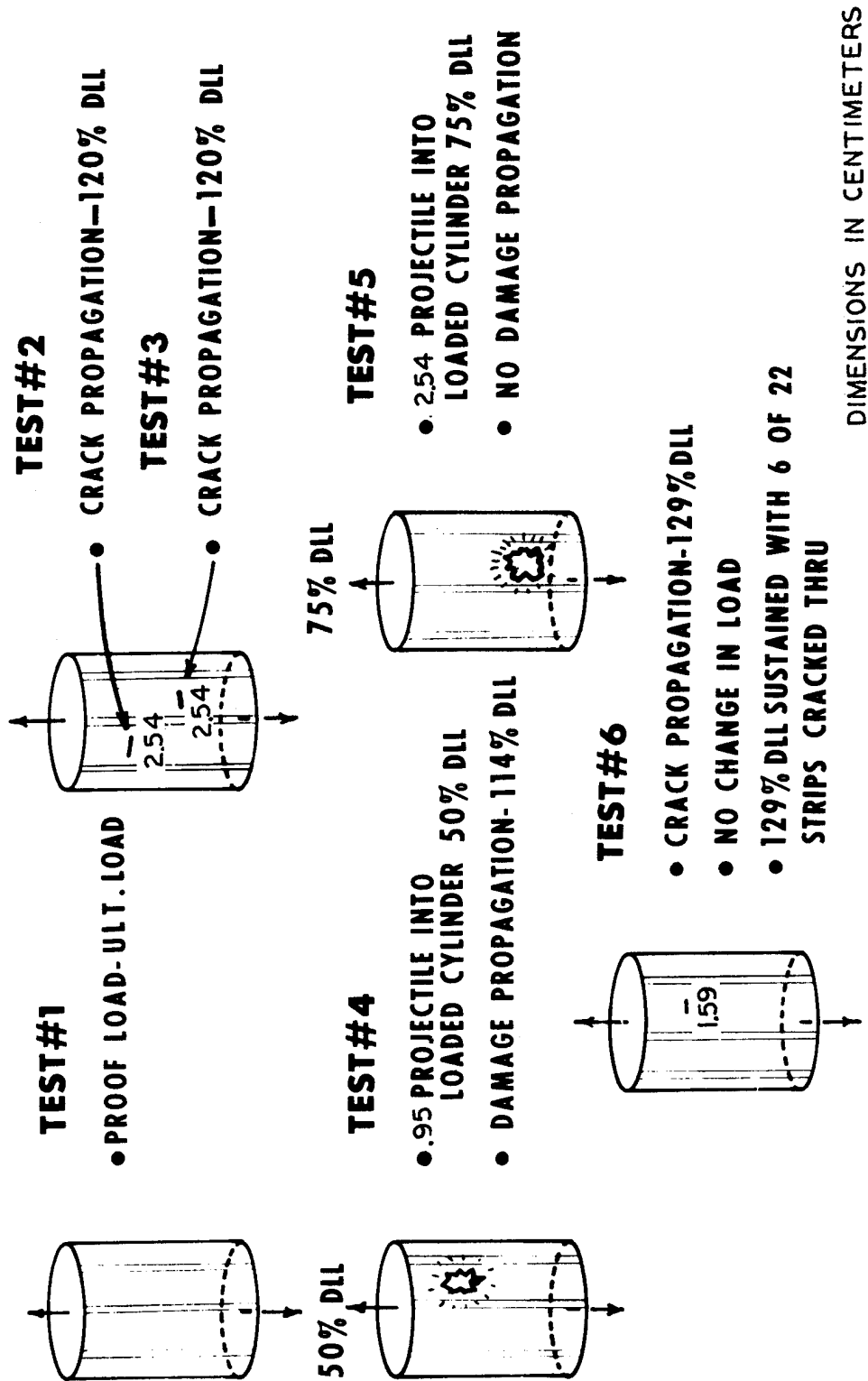

Figure 7-13. Summary of Crack Arrestment Tests

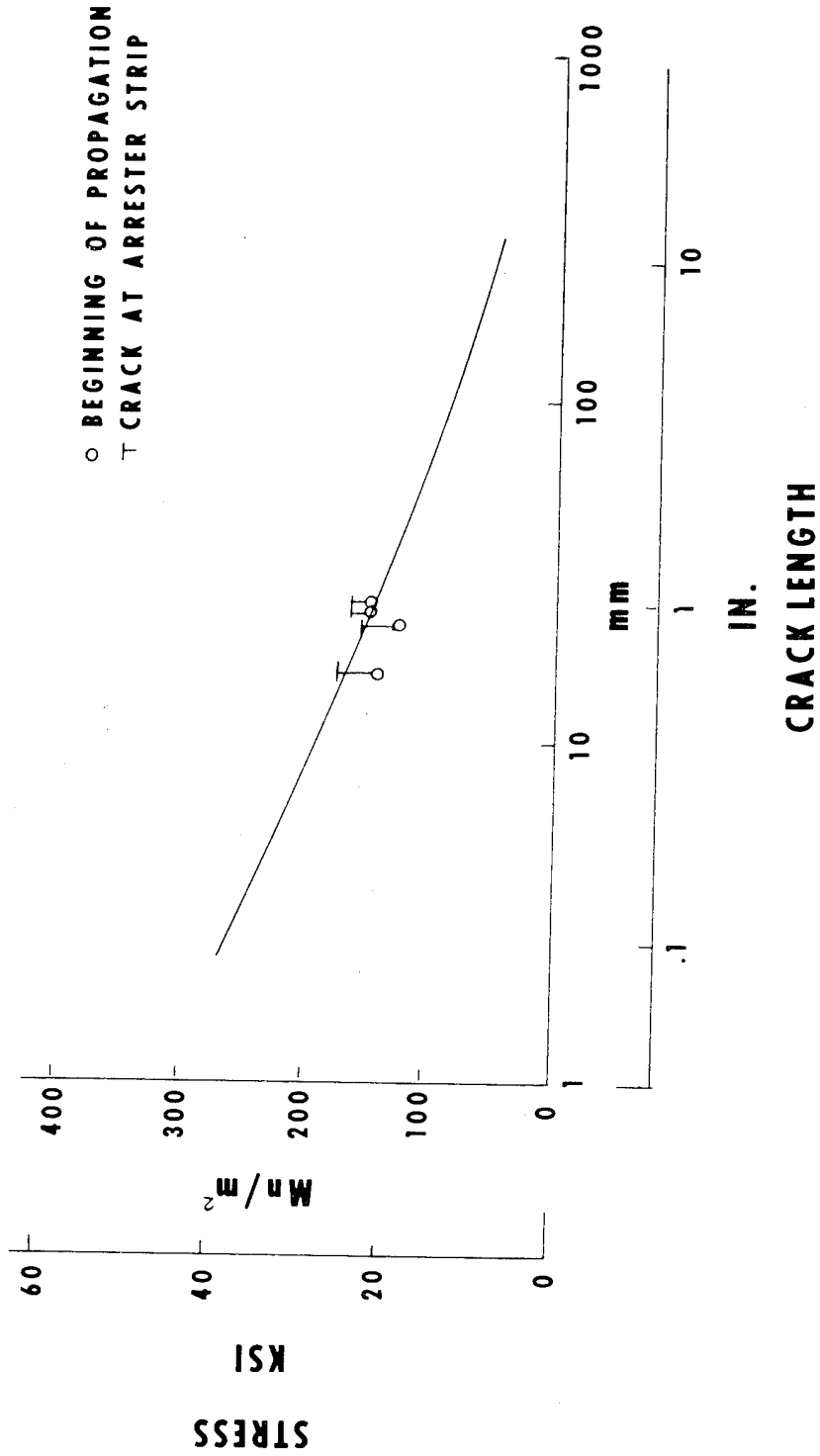
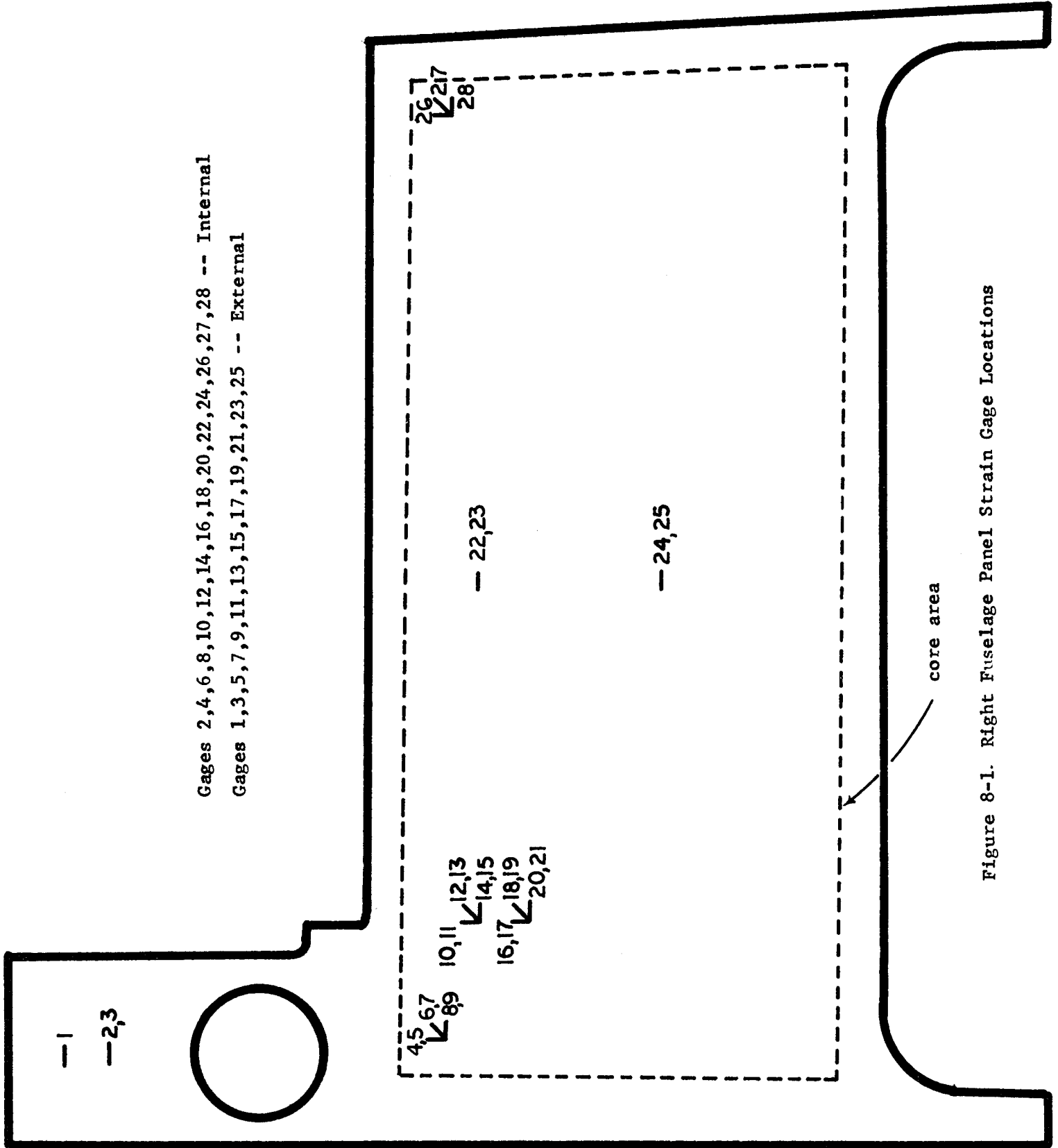

Figure 7-14. Hybrid Cylinder Crack Propagation Comparison to Theory



Gages 2, 4, 6, 8, 10, 12, 14, 16, 18, 20, 22, 24, 26, 27, 28 -- Internal
Gages 1, 3, 5, 7, 9, 11, 13, 15, 17, 19, 21, 23, 25 -- External

Figure 8-1. Right Fuselage Panel Strain Gage Locations

Gage 29 - External
Gage 30 - Internal

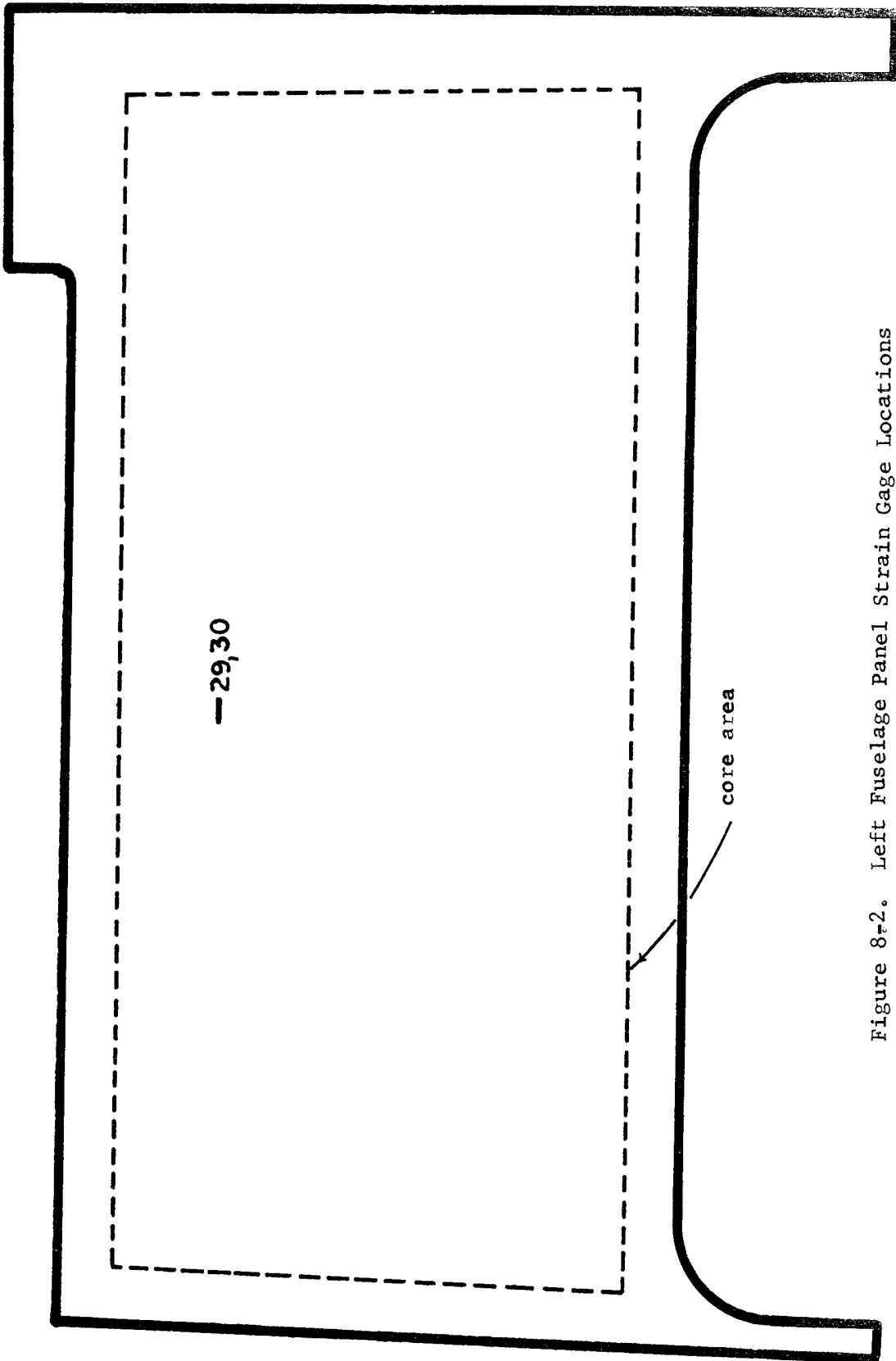

Figure 8-2. Left Fuselage Panel Strain Gage Locations

Gage 31 - External
Gage 32 - Internal

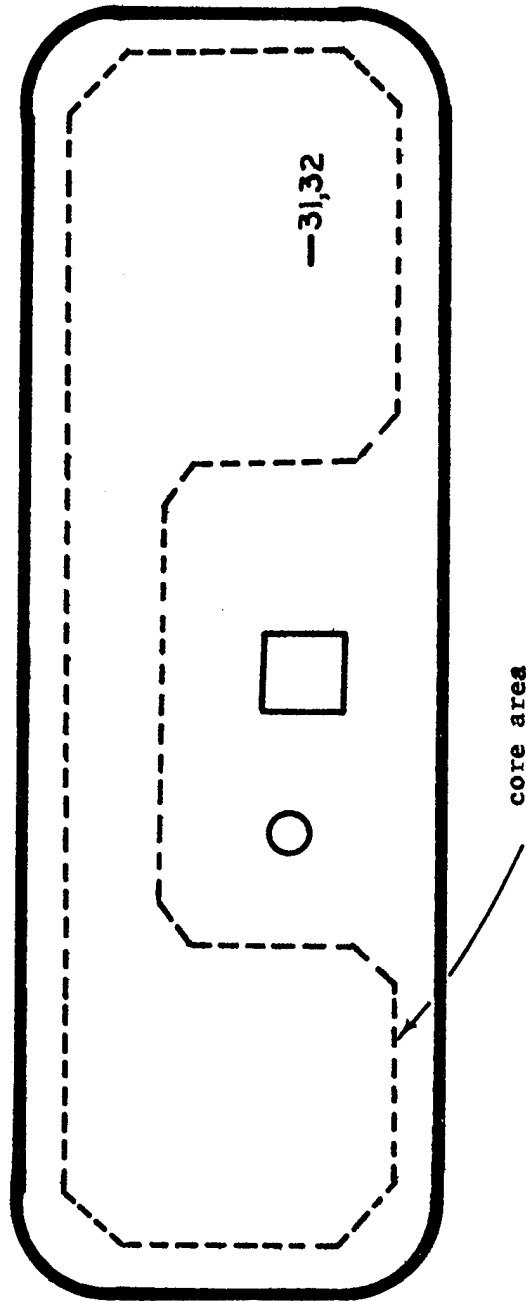

Figure 8-3. Access Door Strain Gage Locations

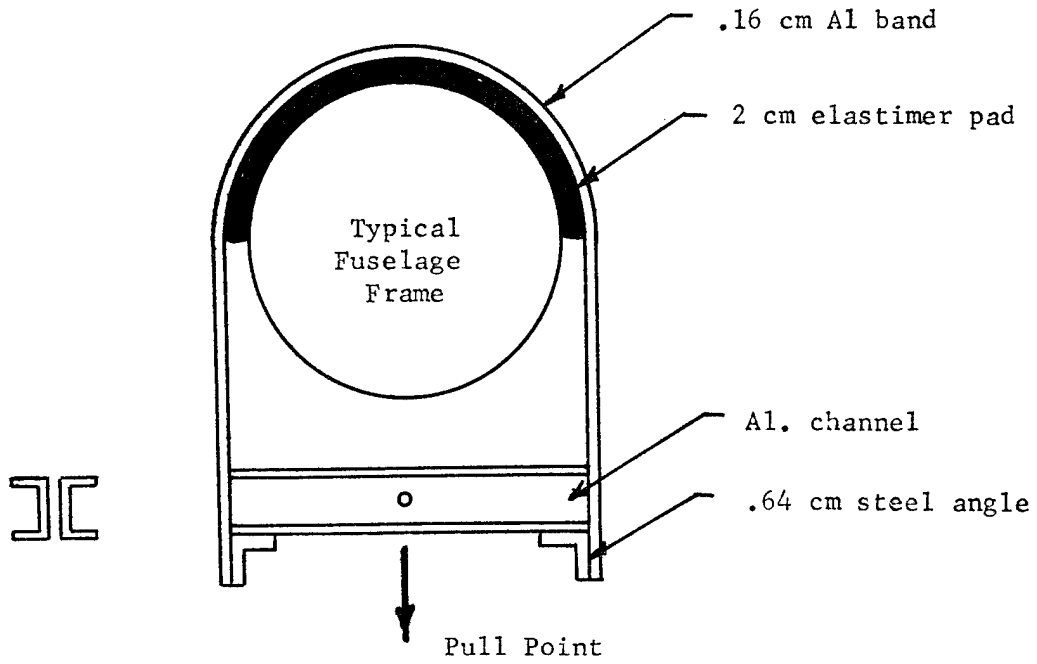

Figure 8-4a. Aluminum Band Loading Station

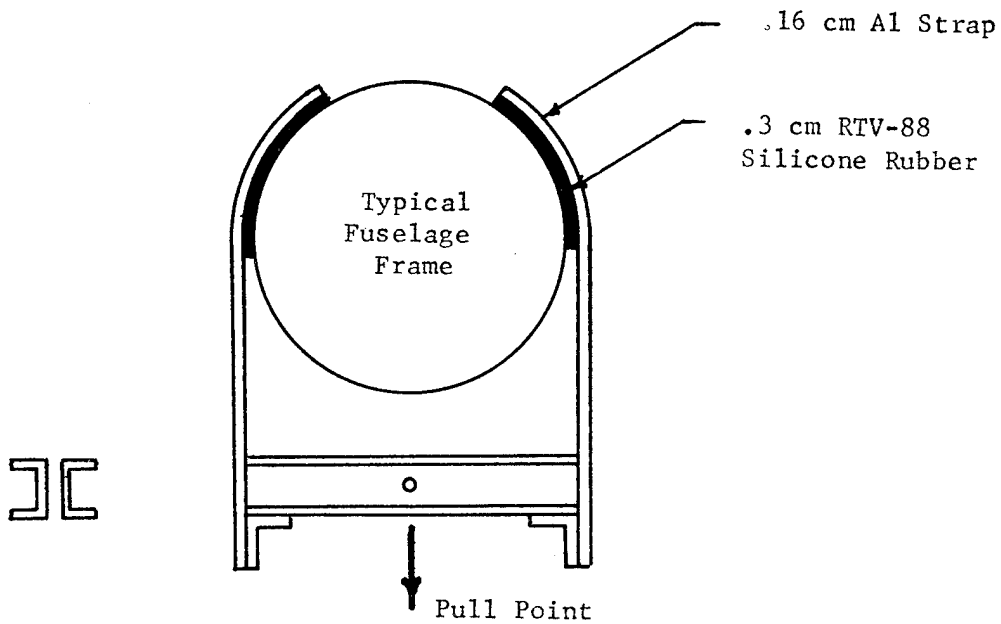

Figure 8-4b. Aluminum Strap Loading Station

of a manually operated hydraulic jack. Figures 8-5 and 8-6 are photographs of the test setup.

8.3 TEST LOAD CONDITIONS AND LOADING SEQUENCE

Two critical flight load conditions were ground tested to demonstrate the overall structural adequacy of the hybrid fuselage design. The two ground tests included a main recovery chute deployment load test and a simulated 5g maneuver loads test, discussed in "Design Conditions".

The loading sequence for both ground tests were identical and the procedure is listed below.

- a. Apply 30% Limit Load
 - o Checkout Instrumentation and Test Set-Up
- b. Apply 50% Limit Load 10 Times
 - o Extrapolate Strain Data to Limit Load and Compare for First and Last Cycle Data with Analytical Data.
- c. Apply Limit Load
 - o Record Strain Data
 - o Evaluate Strain
- d. Apply Limit Load 5 Times
 - o Record Data

Actual fuselage station applied loads are listed in Tables 8-1 and 8-2, for the recovery loads test and the 5g maneuver loads test, respectively. Loading stations are illustrated in Figure 8-7. Fuselage station shear diagrams for both load conditions are shown in Figures 8-8 and 8-9. Moment diagrams are also included in Figures 8-10 and 8-11. Limit loads developed on the fuselage center section for both conditions are shown in Figures 8-12 and 8-13.

8.4 FUSELAGE TESTING, RECOVERY LOADS

The hybrid fuselage was initially set up for the main recovery chute deployment load test. The loading sequence followed during this test was previously described.

Testing of the recovery load condition ran smoothly through steps (a) and (b) of the test procedure, the gages behaving linearly to the applied loads. Step (c) in the test procedure to limit load was next applied to the fuselage. At 80% DLL the onset of nonlinear strain behavior was observed in most of the forward gages, the most significant nonlinear strain response being observed by gages 4, 5, 6, 7, 10 (refer to Figures 8-1 and 8-2). A second cycle to

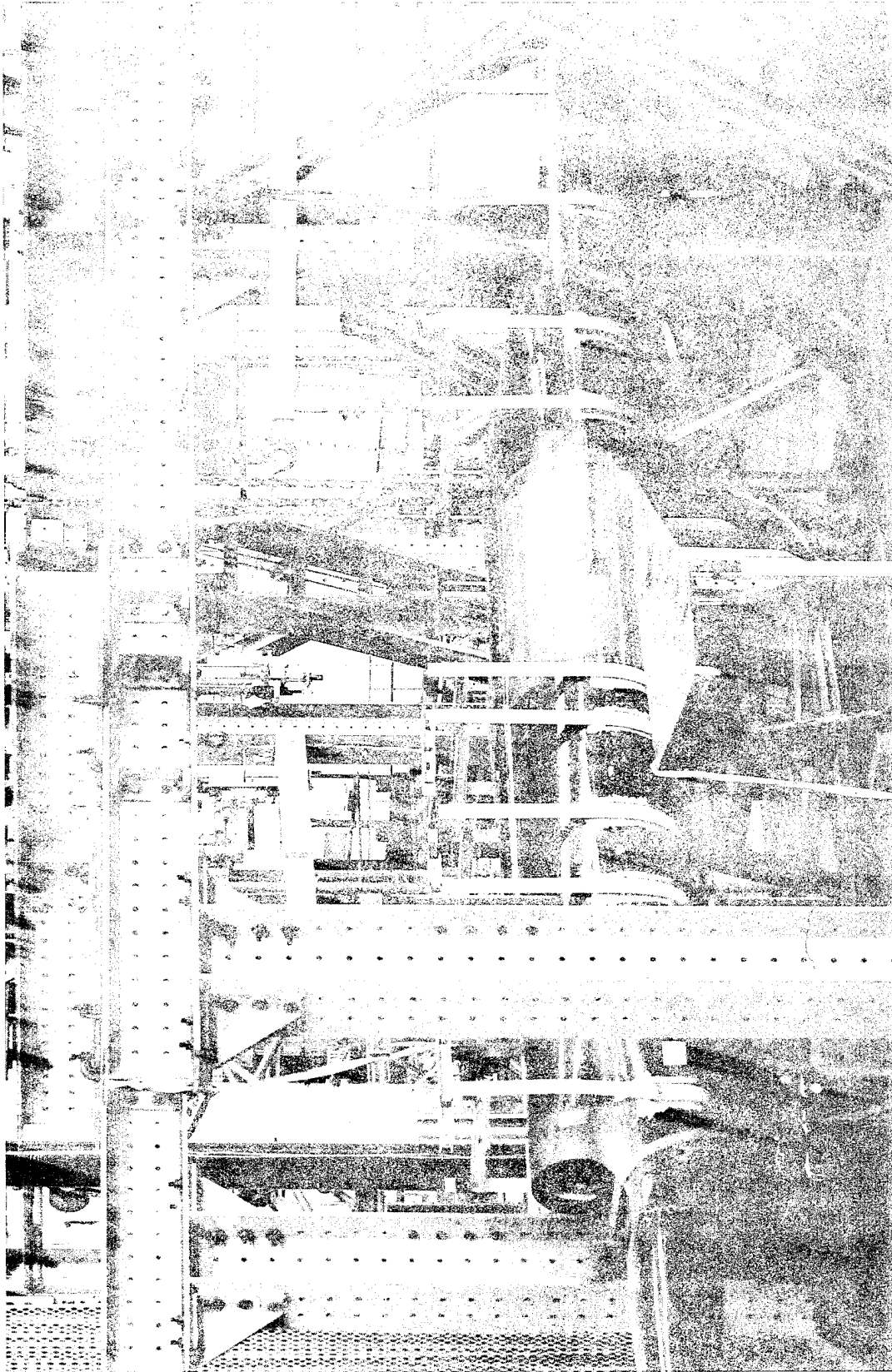

Figure 8-5. Recovery Load Test Setup

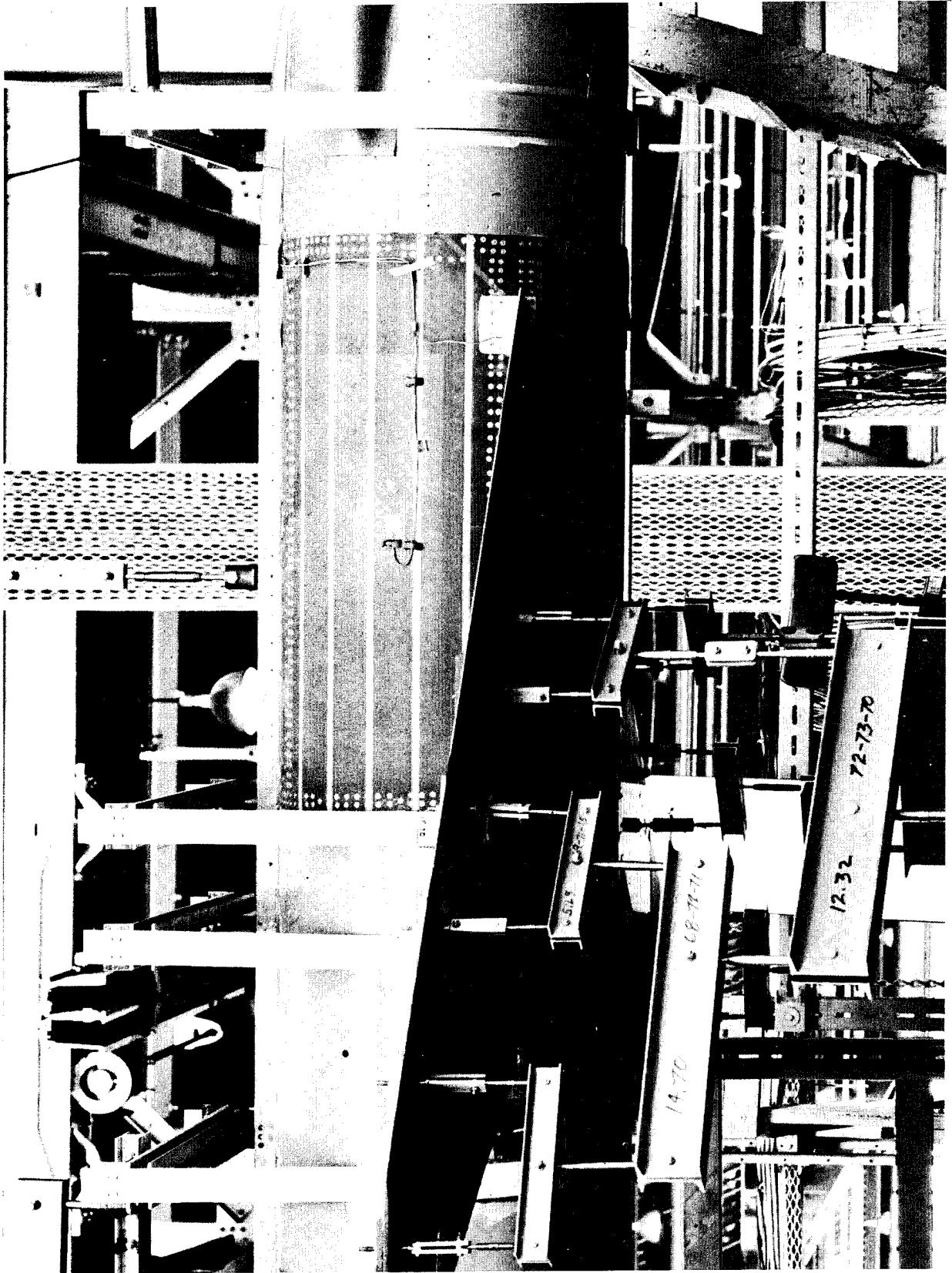

Figure 8-6. 5g Maneuver Load Test Setup

TABLE 8-1

APPLIED LOADS - RECOVERY CONDITION

<u>FUSELAGE STATION</u>	<u>APPLIED LOAD</u>	
	<u>N</u>	<u>LBS</u>
118.50	-2558	-575
134.30	-2224	-500
166.30	-6672	-1500
182.50	-3670	-825
209.00	-5462	-1228
224.80	-2175	-489
245.00	51155	11500
274.10	-6615	-1487
285.20	-4875	-1096
301.90	-6228	-1400
315.20	-6672	-1500
325.00	-2669	-600
350.00	-1334	-300

TABLE 8-2

APPLIED LOADS - 5G MANEUVER CONDITION

<u>FUSELAGE STATION</u>	<u>APPLIED LOAD</u>	
	<u>N</u>	<u>LBS</u>
166.30	-2891	-650
182.50	-2891	-650
209.00	-2211	-497
224.80	- 903	-203
258.34	-13122	-2950
Wing Loading	39189	8810
301.90	-3550	-798
315.20	-1610	-362
325.00	-2669	-600
350.00	-9341	-2100

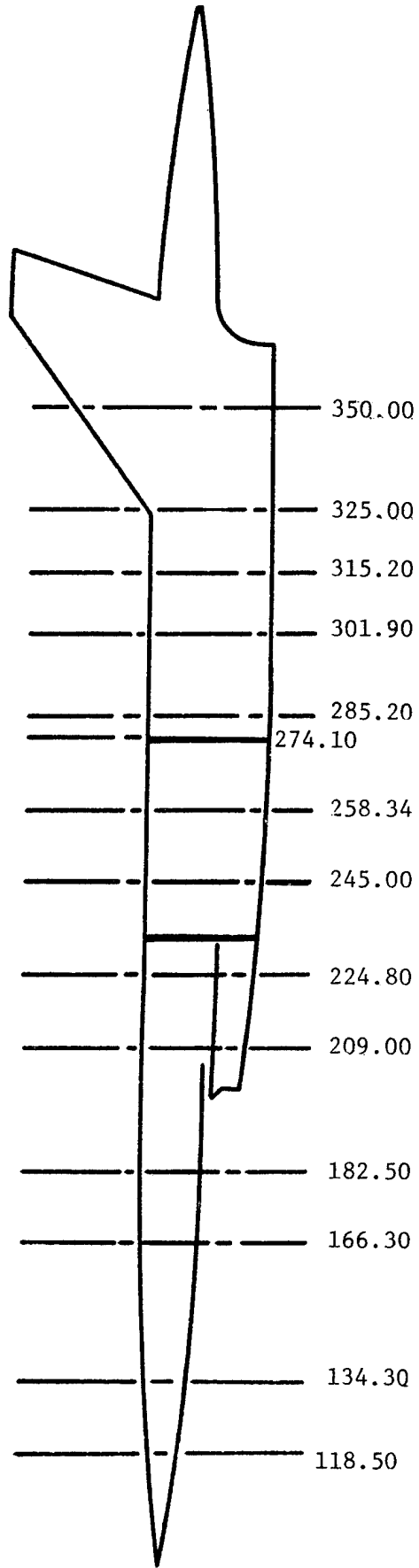

Figure 8-7. Frame Loading Stations

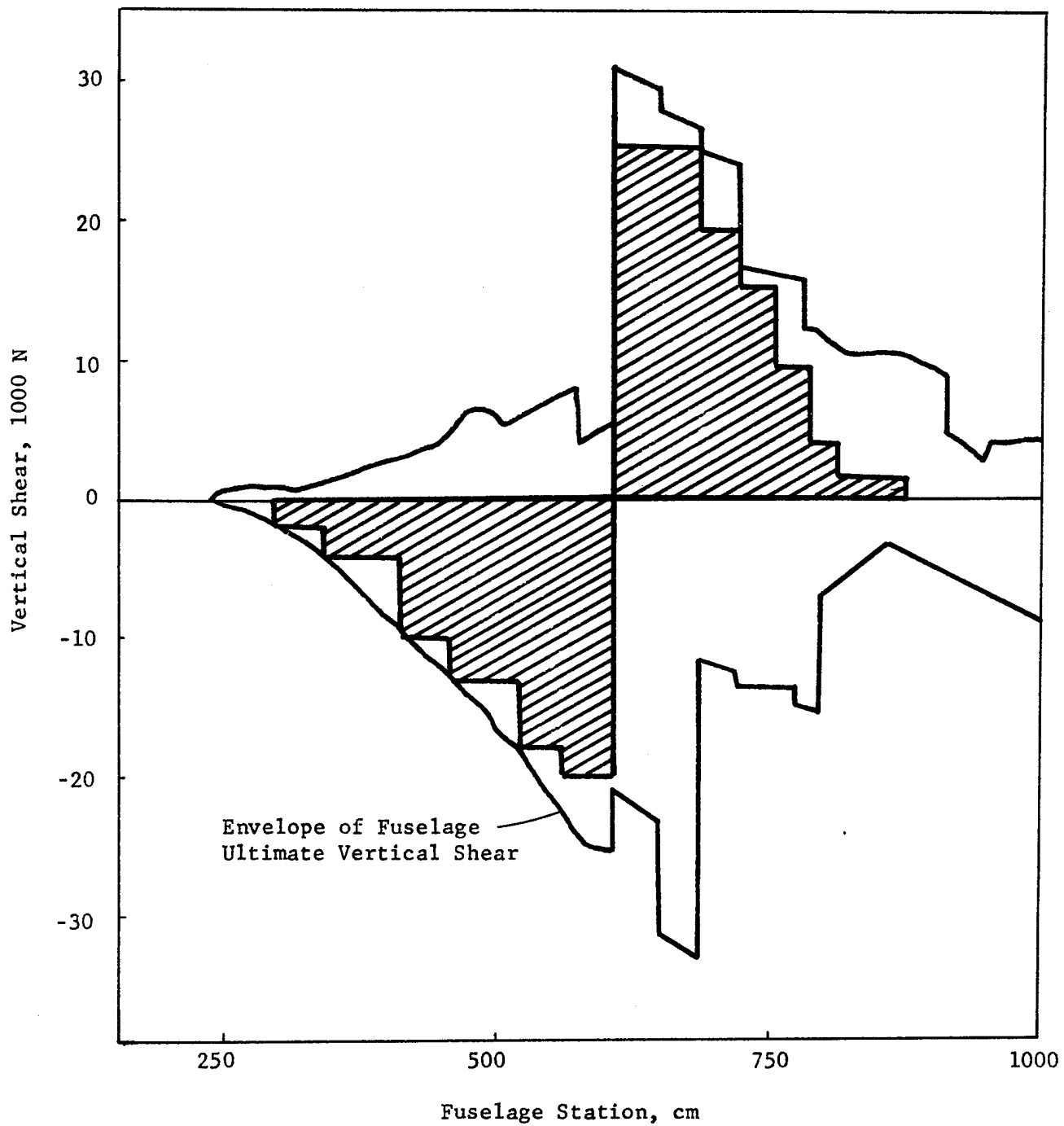

Figure 8-8. Fuselage Shear Diagram - Simulated Recovery Loads

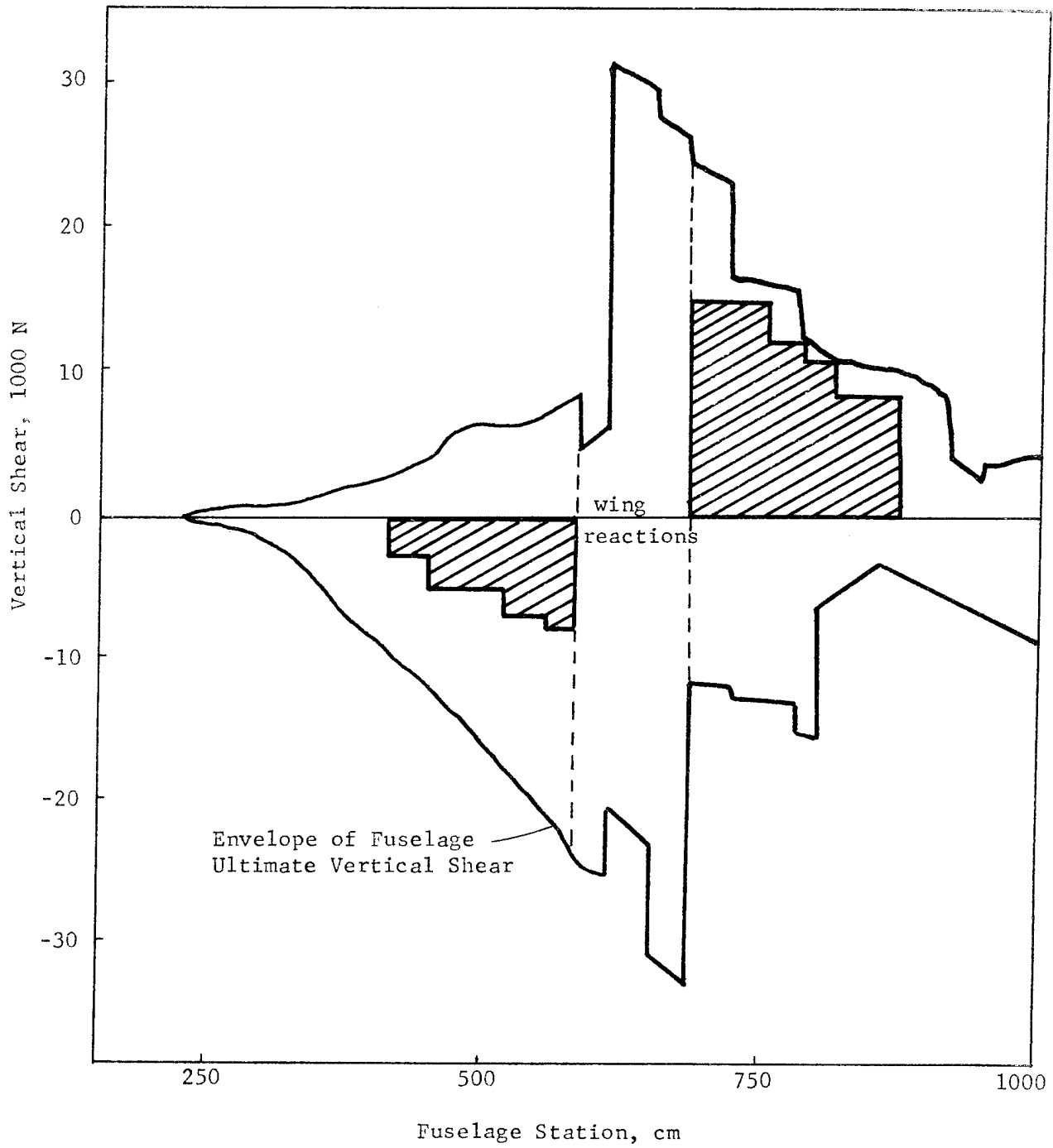

Figure 8-9. Fuselage Shear Diagram - Simulated 5g Maneuver Loads

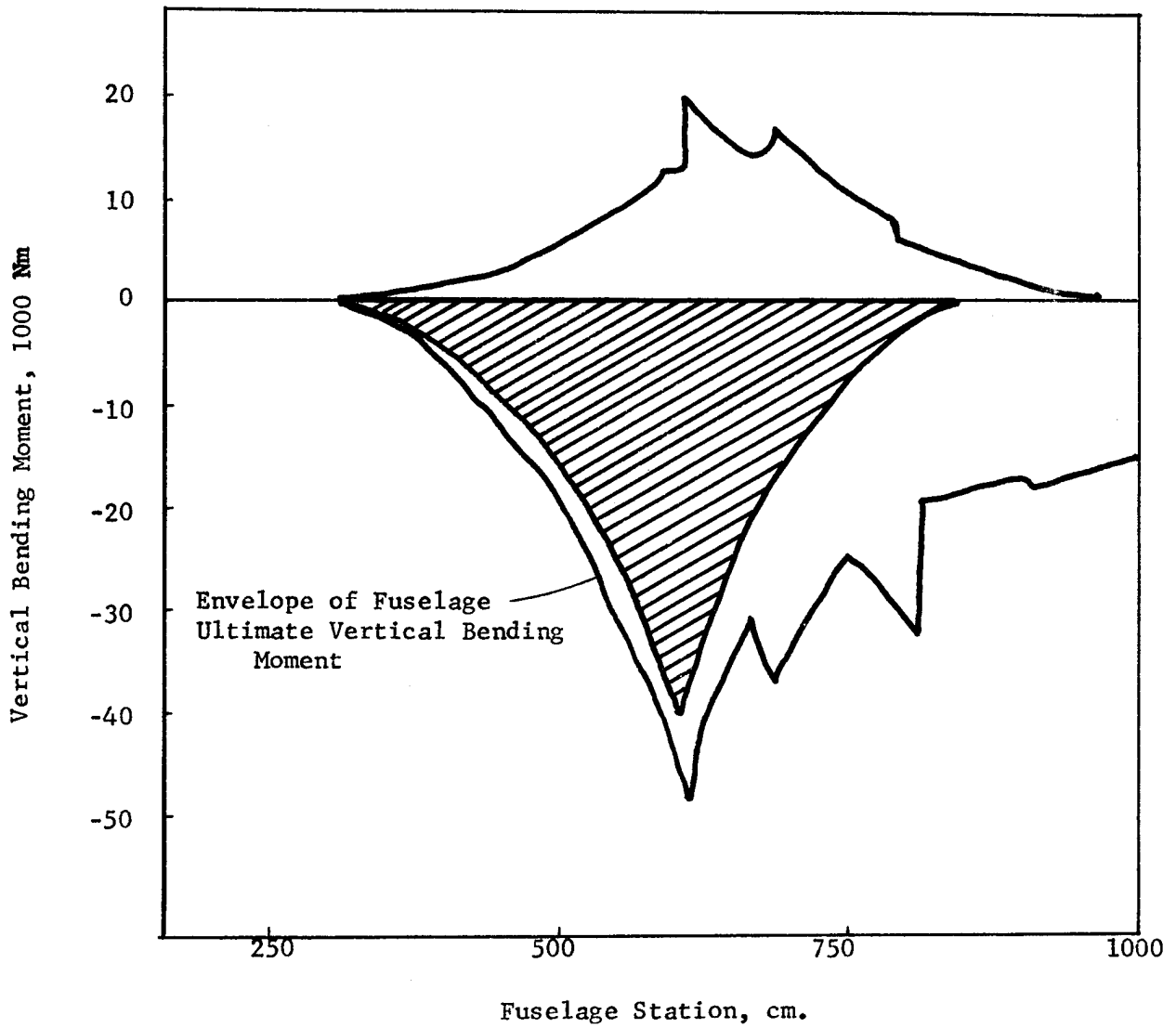

Figure 8-10. Fuselage Moment Diagram - Simulated Recovery Loads

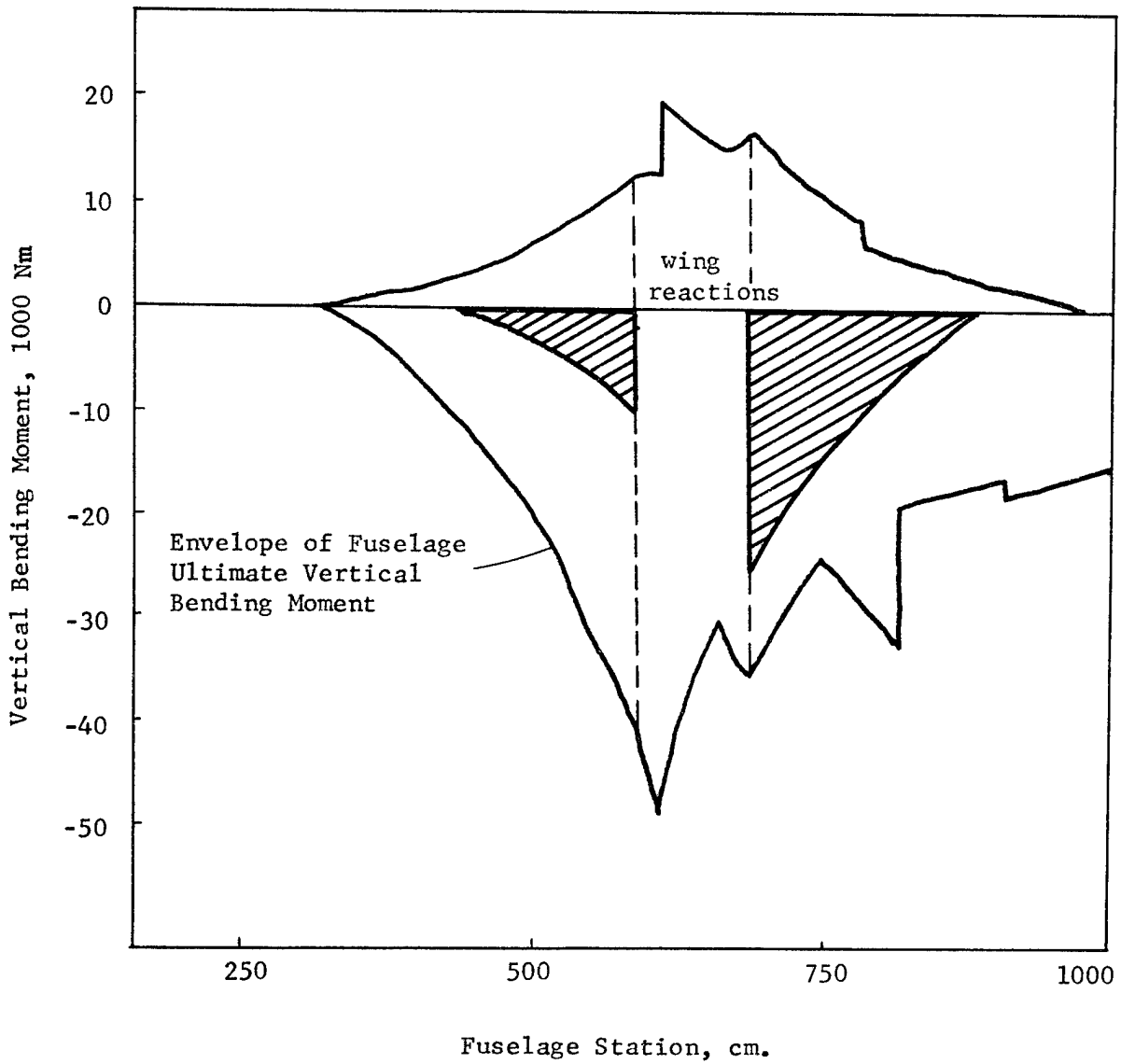

Figure 8-11. Fuselage Moment Diagram - Simulated 5g Maneuver Loads

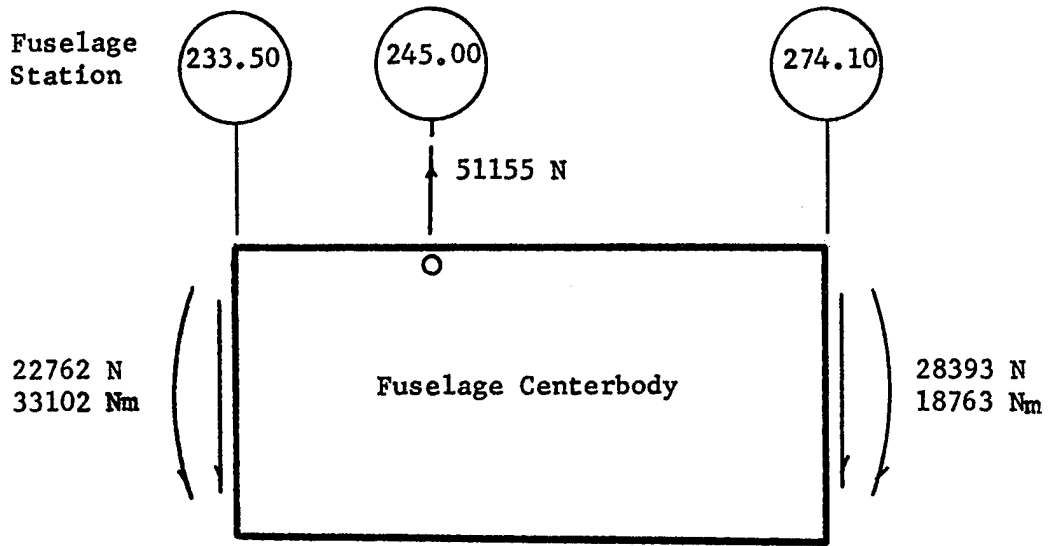

Figure 8-12. Simulated Recovery Loads

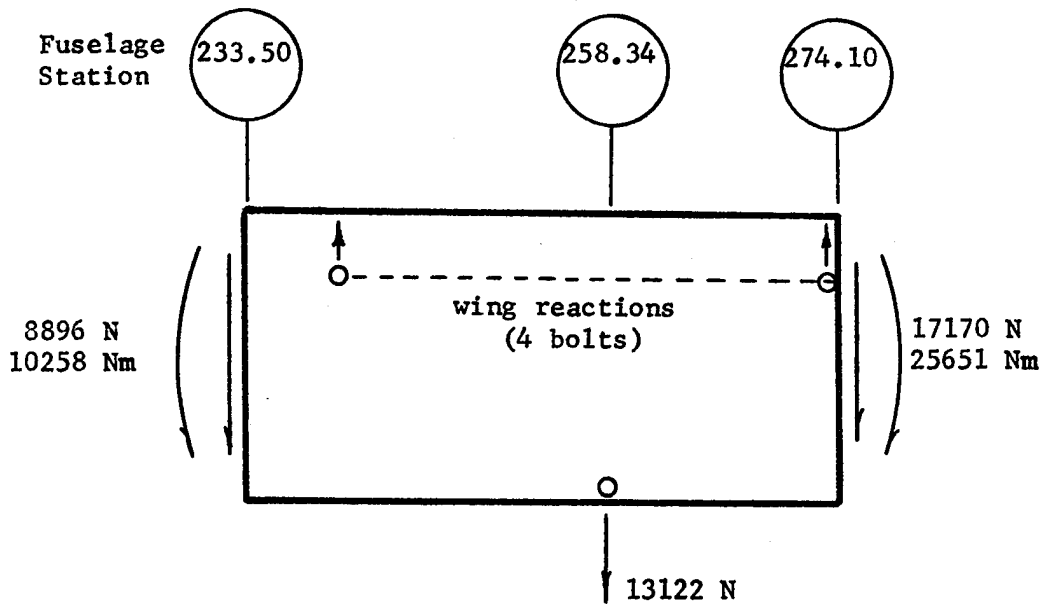

Figure 8-13. Simulated 5g Maneuver Loads

limit load was applied with the same nonlinear strain behavior initiating at 80% DLL. Typical strain data showing the nonlinear behavior is shown in Figures 8-14 and 8-15.

After applying 50% DLL of the third DLL cycle, it was decided to terminate the testing and examine the fuselage for possible damage. Inspection revealed that cracks of approximately 7.62 cm (3 in.) in length had propagated on both left and right fuselage panels, from the 90° corner where the solid laminate area extends above the forward wing attachment bolt hole, see Figures 8-16 and 8-17. The cracks which run parallel to the Gr/Ep longitudinal fibers are shown in detailed photographs by Figures 8-18 and 8-19.

8.5 FUSELAGE FAILURE ANALYSIS AND REPAIRS

After an examination of the crack and a review of the substructure drawings, the cause of the failure was readily determined. The parachute load which goes into the partial bulkhead at station 241 must be transferred into the fuselage skin, or outer shell. In the metal design, this is done by frame at station 241. However, in the composite version, this frame was removed along with the other intermediate frames, and this forced the load to take a path through the composite material in the circumferential direction for a short distance. Since no fibers run in this direction in the composite fuselage design, the induced stresses were excessive and cracking resulted.

The course of action to prevent this would most likely have been to leave part of the frame at station 241 in the fuselage. Alternately, 90° fibers could have been added at that point to increase the load carrying capability. The failure which did occur, however, is a local problem and in no way detracts from the basic composite design. A repair was designed which would provide an adequate load path for the parachute loads to be transferred into the composite honeycomb shell.

The damaged areas on the left and right fuselage panels were repaired with fiberglass patches which were both bonded and bolted to the hybrid laminate.

The fiberglass patches were fabricated from SP 250 prepreg and consisted of 16 plies with (0°, +45°, 0°)_{2S} orientations, the 0° fibers running in the circumferential direction. The patches were laid up on the small center fuselage section access door which substituted as a curing tool. Using the access door as a tool insured the patch would have the exact fitting inside diameter. After cure, the patches were cut to fit the damaged area; the patch configurations are illustrated in Figure 8-20. Existing rivet holes in the damaged area of the fuselage were located and the patches were drilled with 4.76 cm (3/16 in.) diameter bolt holes.

EA9309 room temperature curing adhesive was applied to the finished patches and, in turn, the patches were bolted to the fuselage panels. Care was taken to hold the bond line thickness constant, by positioning .1 mm (.005 in.) diameter fiberglass thread between the patch and the fuselage panels. The 4.76 mm (3/16 in.) diameter bolts were finger-tightened to

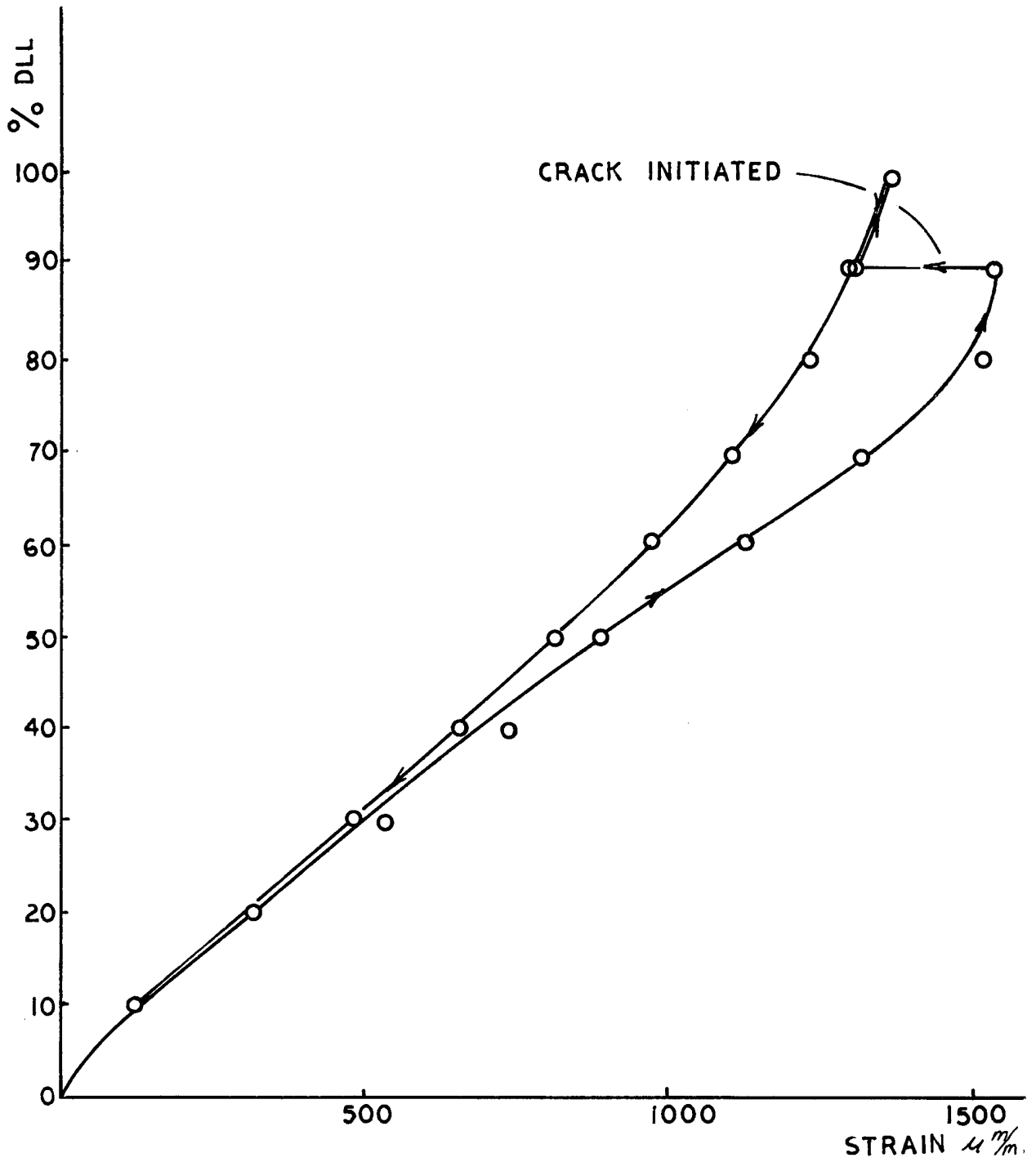

Figure 8-14. Gage 4 Strains on 1st Run to DLL

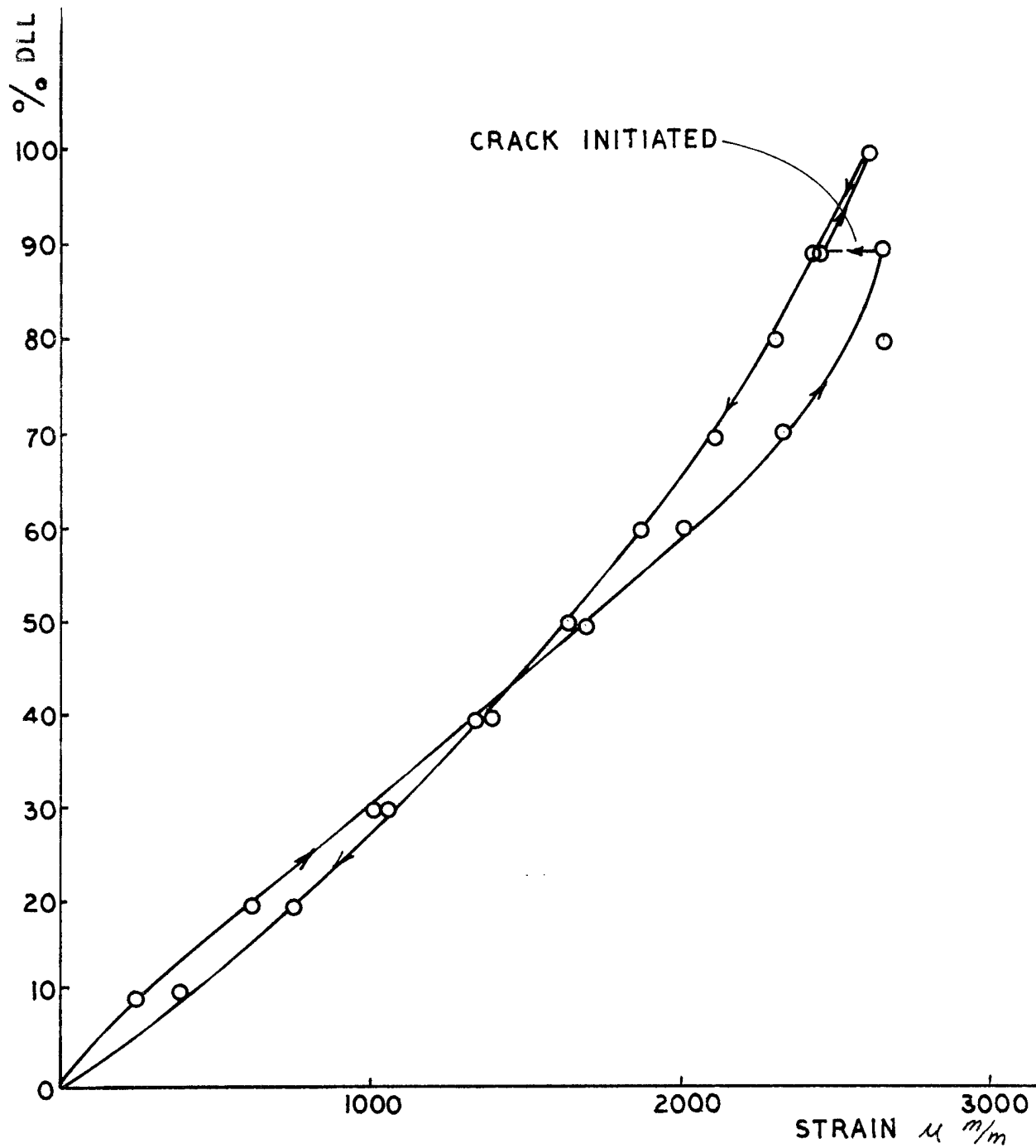

Figure 8-15. Gage 10 Strains on 1st Run to DLL

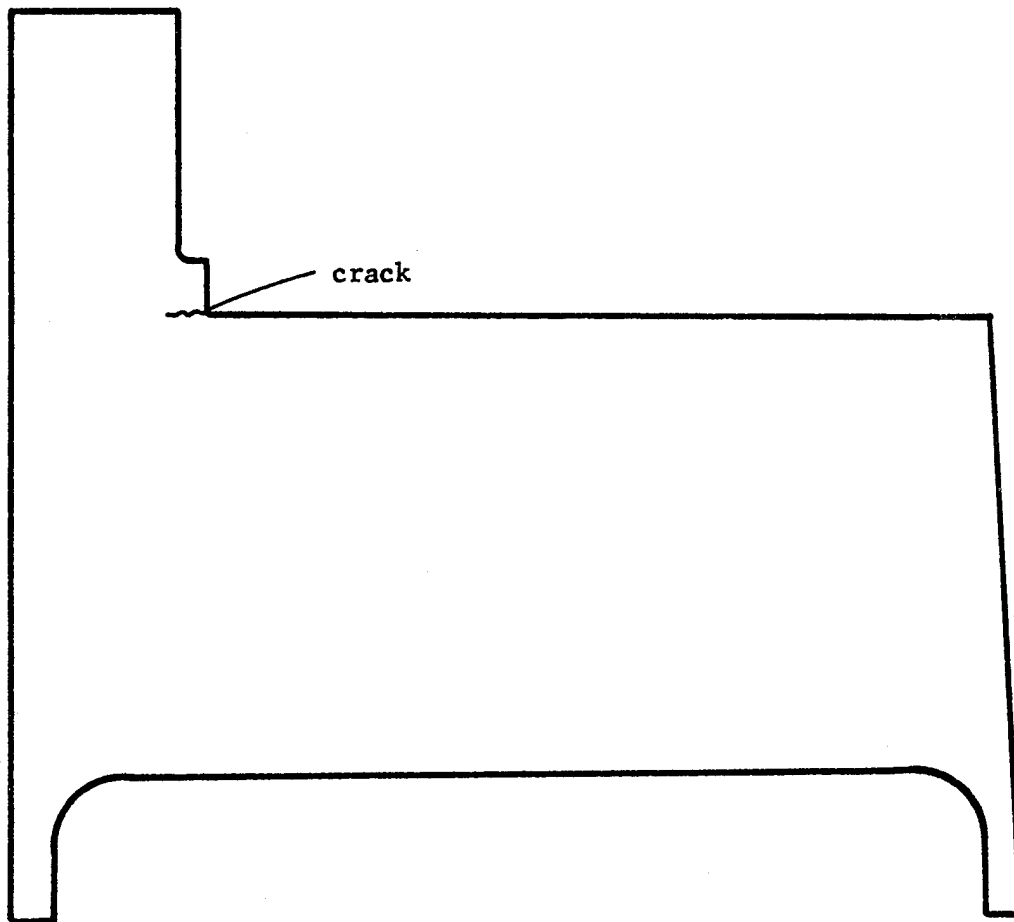

Figure 8-16. Crack in Right Fuselage Panel

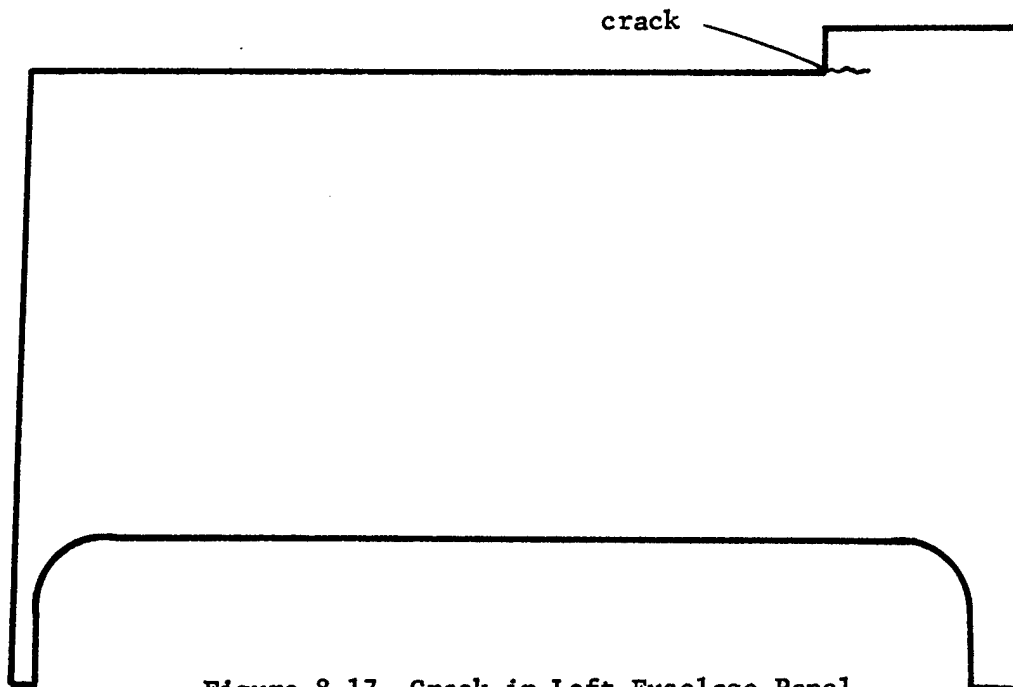

Figure 8-17. Crack in Left Fuselage Panel

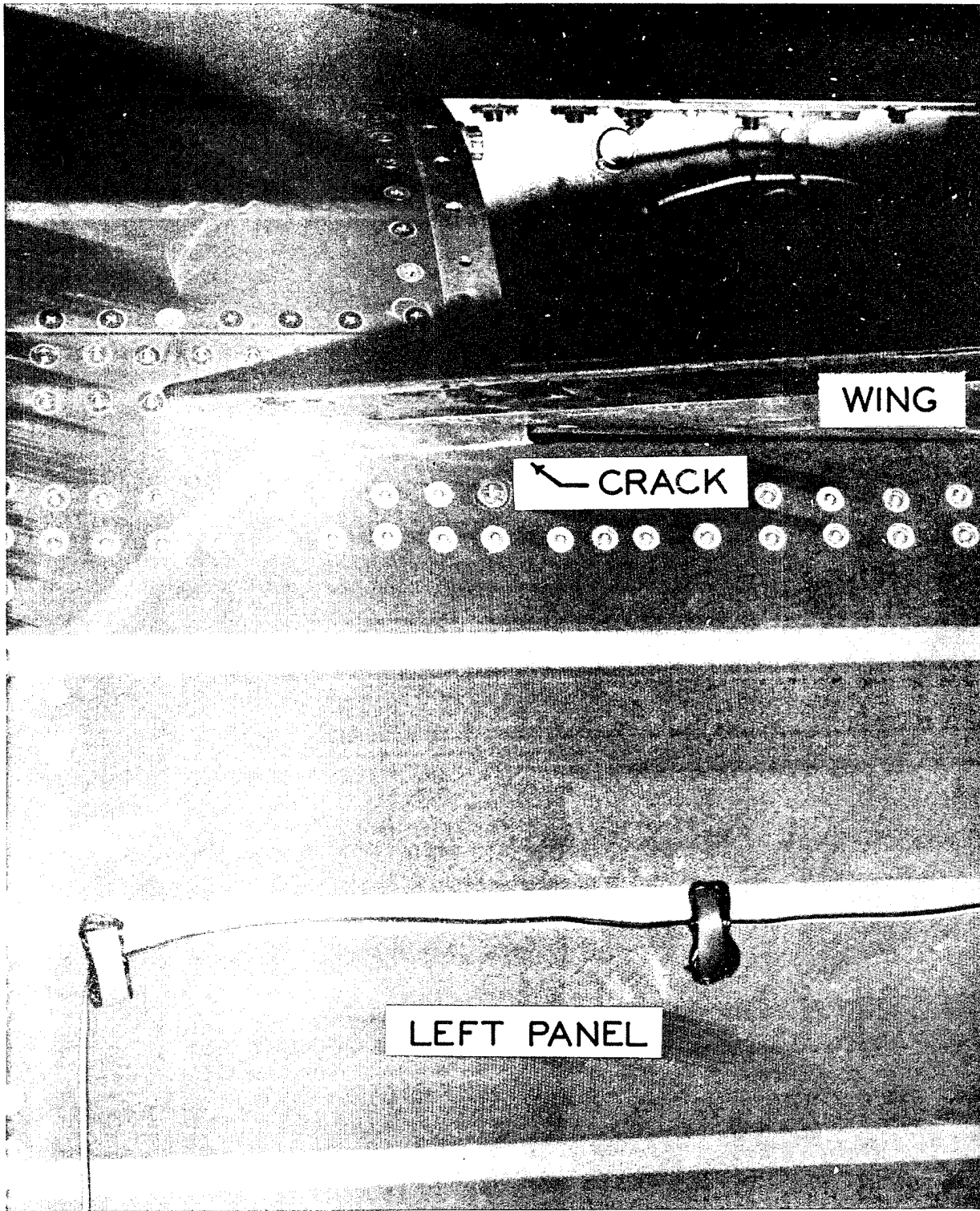

Figure 8-18. Photograph of Crack in Left Fuselage Panel

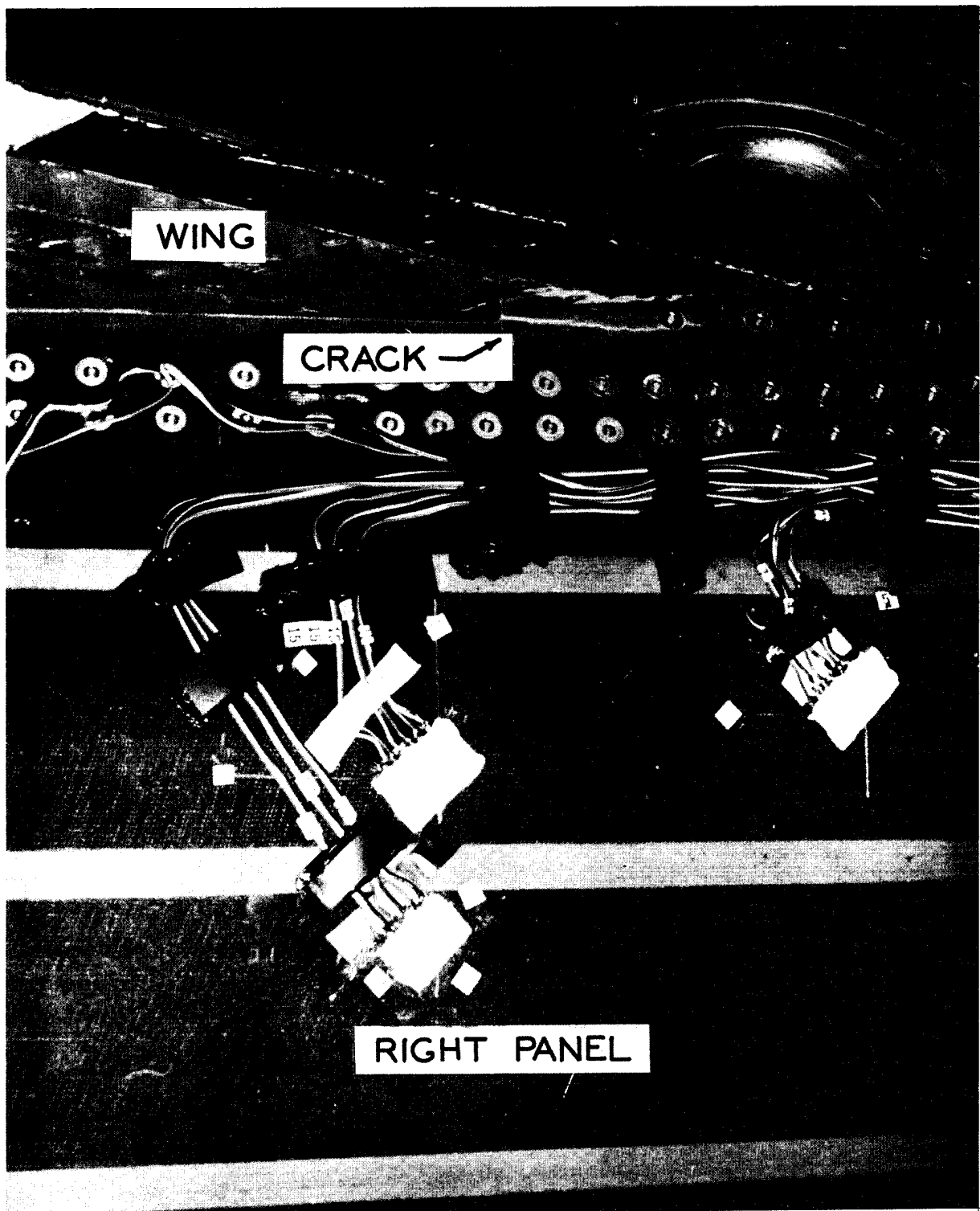

Figure 8-19. Photograph of Crack in Right Fuselage Panel

16 PLY SP250 FIBER GLASS

$(0, \pm 45, 0)_{2S}$

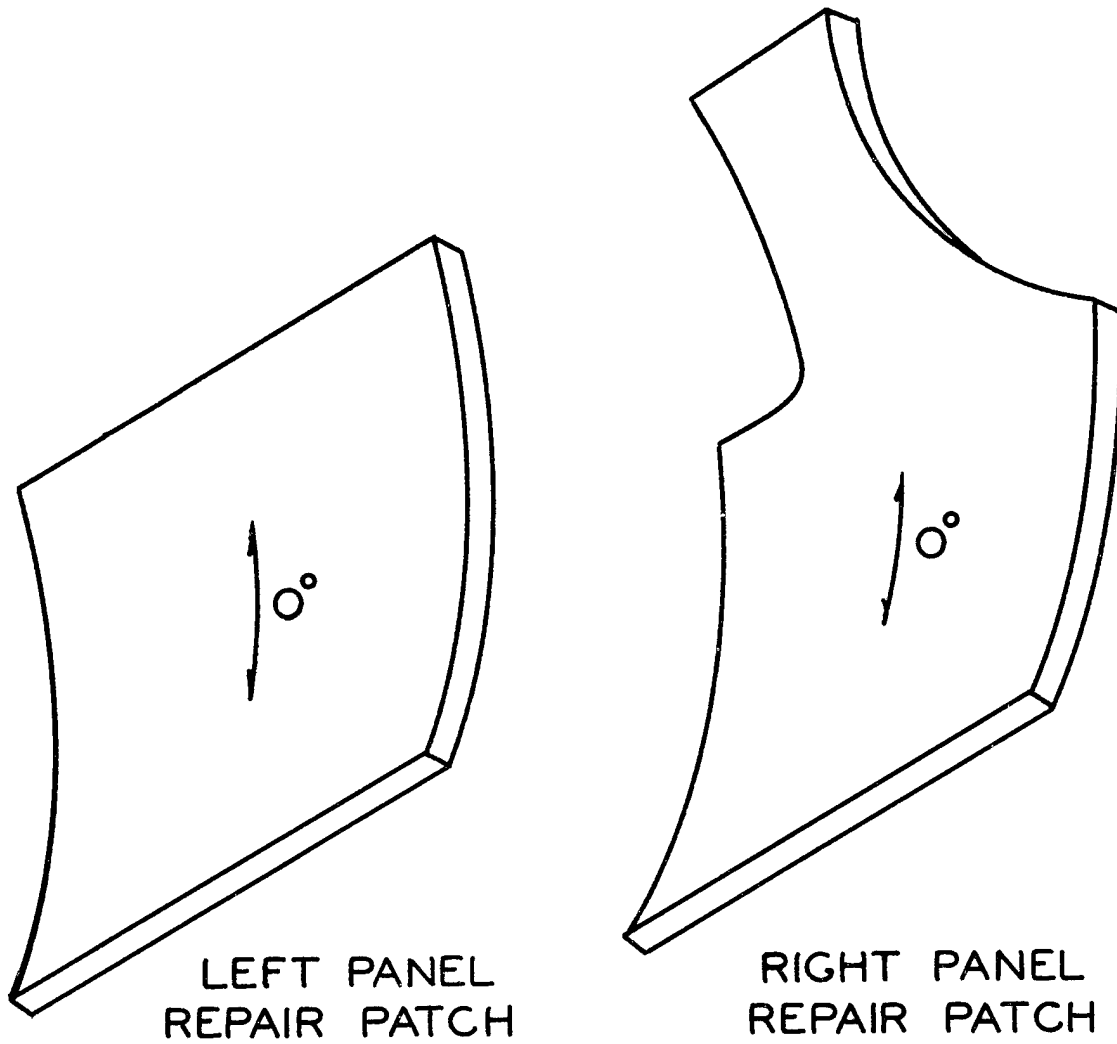

Figure 8-20. Fuselage Repair Configuration

prevent squeezing out the adhesive from between the patch and the fuselage. After the adhesive cured, the bolts were wrench-tightened. The repaired areas are shown in photographs in Figures 8-21 and 8-22.

Figures 8-23 and 8-24 show the patch locations on the damaged areas of the right and left hybrid fuselage panels, respectively. Each patch was instrumented with an axial gage aligned circumferentially.

8.6 RECOVERY LOADS TEST II (AFTER REPAIR)

The hybrid composite fuselage was successfully tested under the recovery loads condition after the damaged areas had been repaired with the fiberglass patches. Test procedures already outlined in the Test Load Conditions and Loading Sequence section were again repeated for this test.

The only unusual occurrence in this test was a sharp noise which was heard at 90% DLL during the first cycle to 100% DLL. A discontinuity was observed in the strain data recorded from the single axial gage located on the right panel fiberglass patch. Inspection revealed no visible damage around the repair area, a partial bond failure between the patch and the fuselage may explain the strain discontinuity. Cycles 2 through 6 resulted in linear strain data, without any other noises being heard.

8.7 5G MANEUVER LOADS TEST

After the hybrid composite fuselage was successfully tested under the recovery load conditions, the test assembly was rearranged for the second test condition, the 5g maneuver loads test. The hybrid composite fuselage successfully withstood the 5g maneuver test to 100% DLL. Strains were relatively low for this loading condition as compared with the more critical recovery loads test. Maximum strains did not exceed 1000 μ m/m at 100% DLL. No unusual noises or nonlinear strain recordings were noted during this test.

8.8 DAMAGE PROOF TEST

At the completion of the original test program, it was decided to induce damage into the right fuselage panel in the areas of highest recorded stress and re-test to 100% DLL. Two holes, approximately 2.5 cm (1 in.) in diameter were punched through the right panel with a sharp 2.5 cm (1 in.) diameter steel bar to simulate ballistic damage. Photos of the holes and their location are shown in Figure 8-25.

It was decided to test the fuselage under the 5g maneuver loads condition for convenience since the fuselage was currently assembled for that test. The fuselage was loaded to 100% DLL with no cracks initiating from the damaged areas. Some noises were heard during the test, although their origin could not be visibly detected.

After the initial test, additional testing was done with more damage being inflicted into the panel after each test. Cutouts of approximately

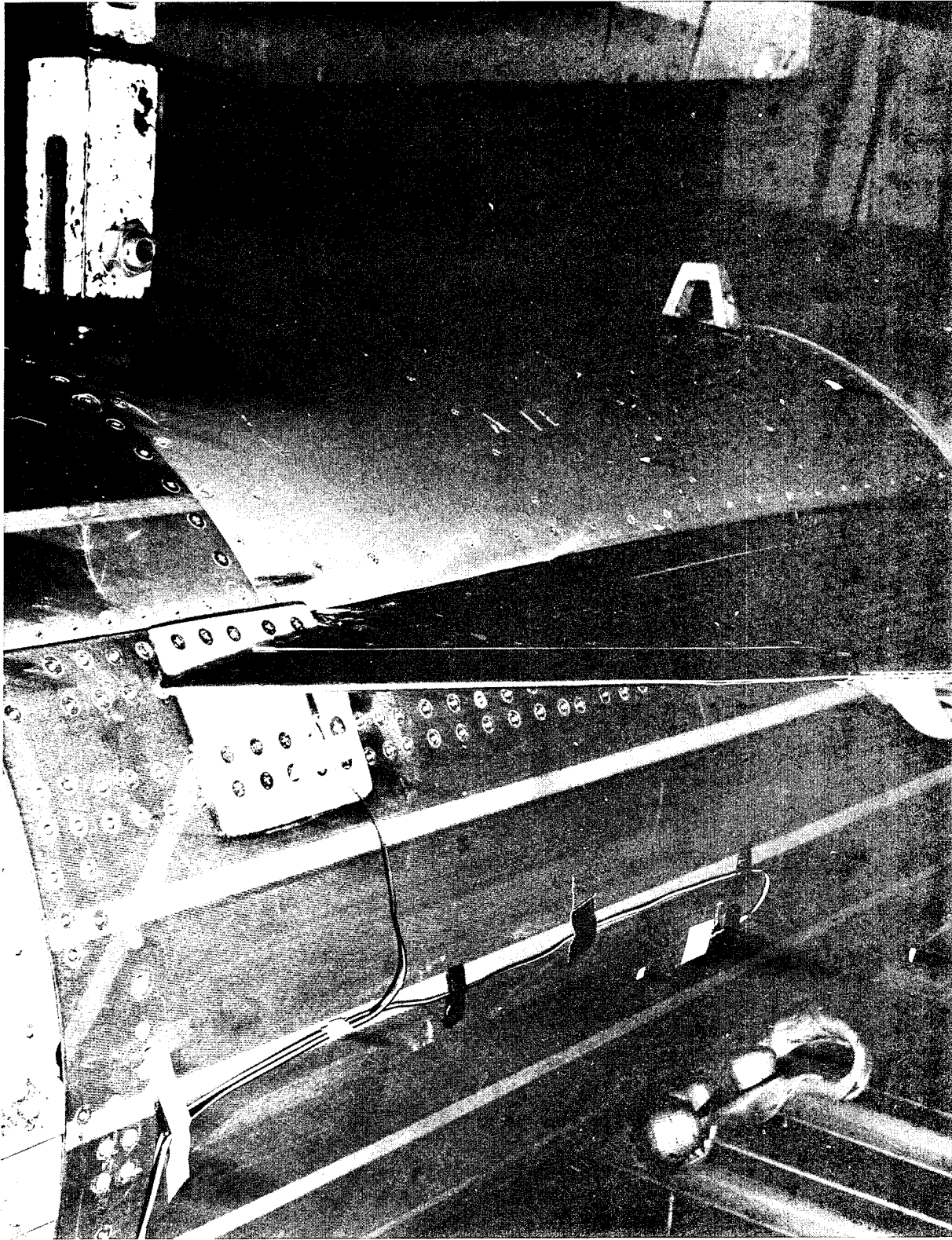

Figure 8-21. Installed Patch on Left Fuselage Panel

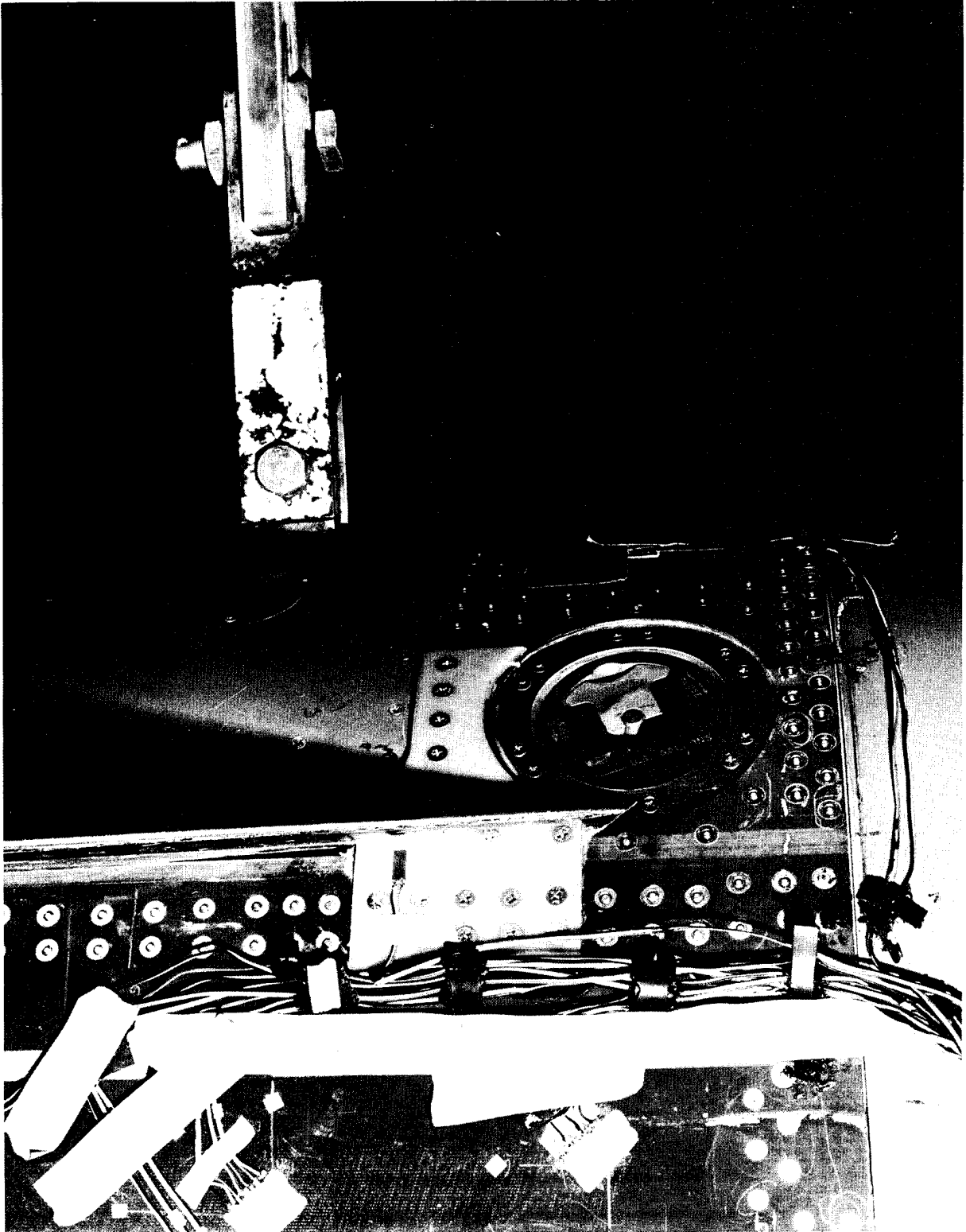

Figure 8-22. Installed Patch on Right Fuselage Panel

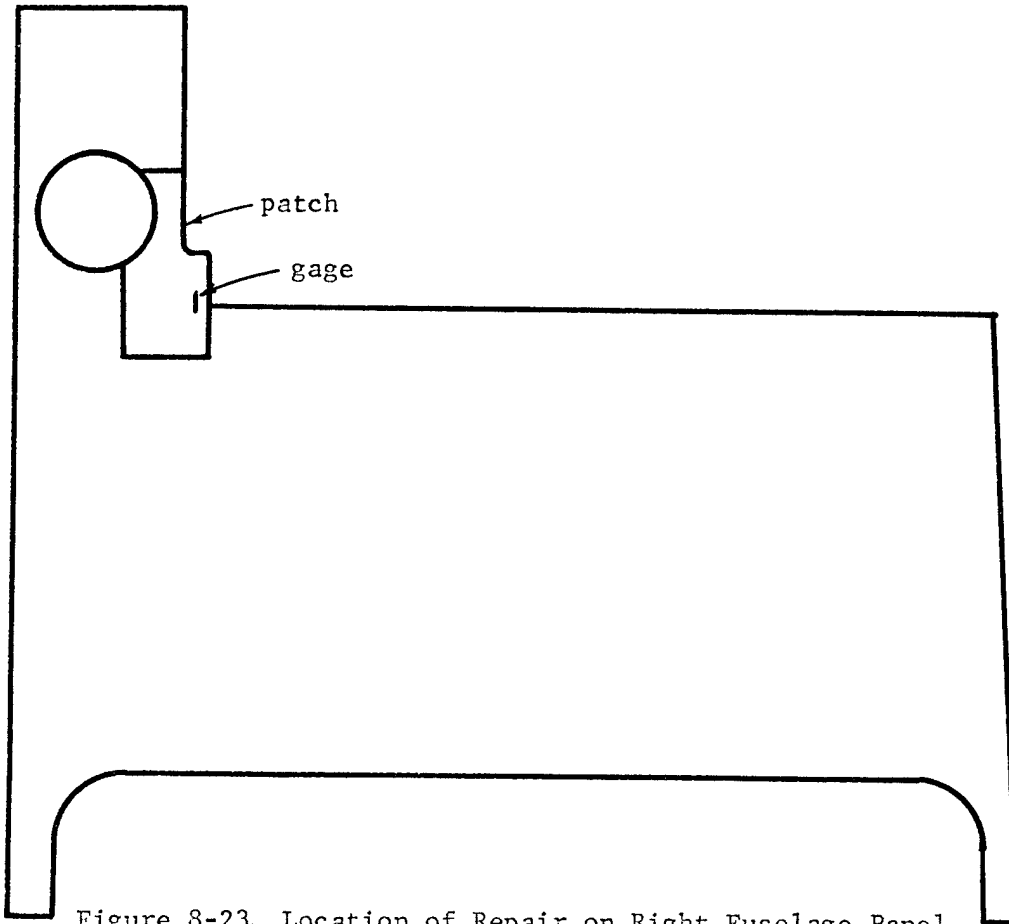

Figure 8-23. Location of Repair on Right Fuselage Panel

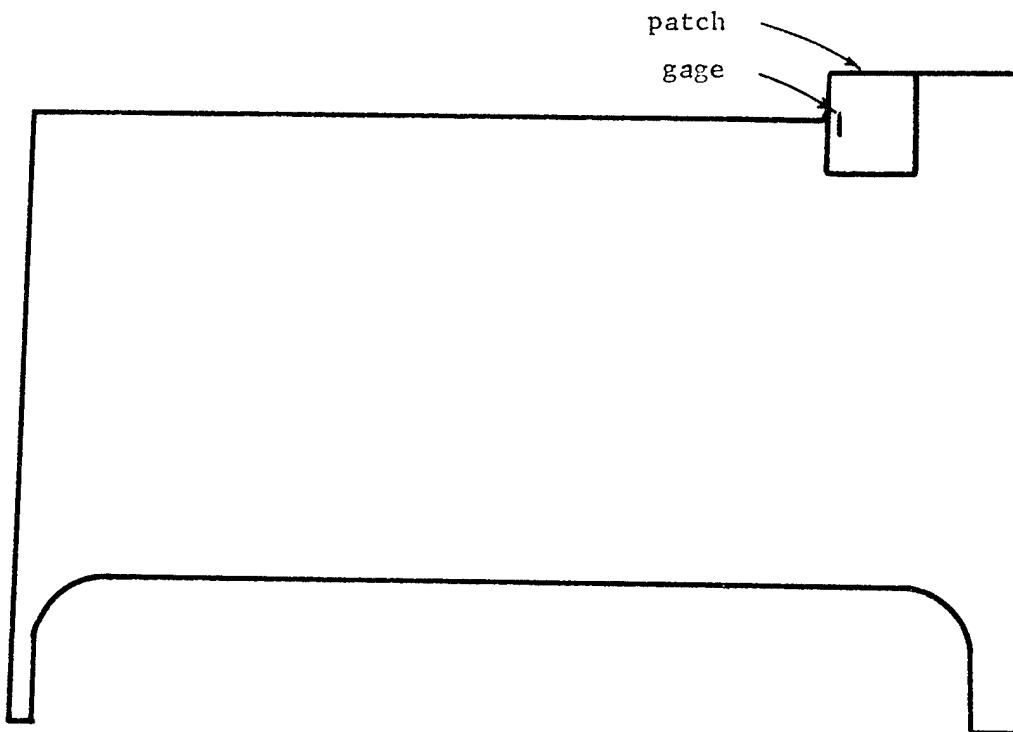

Figure 8-24. Location of Repair on Left Fuselage Panel

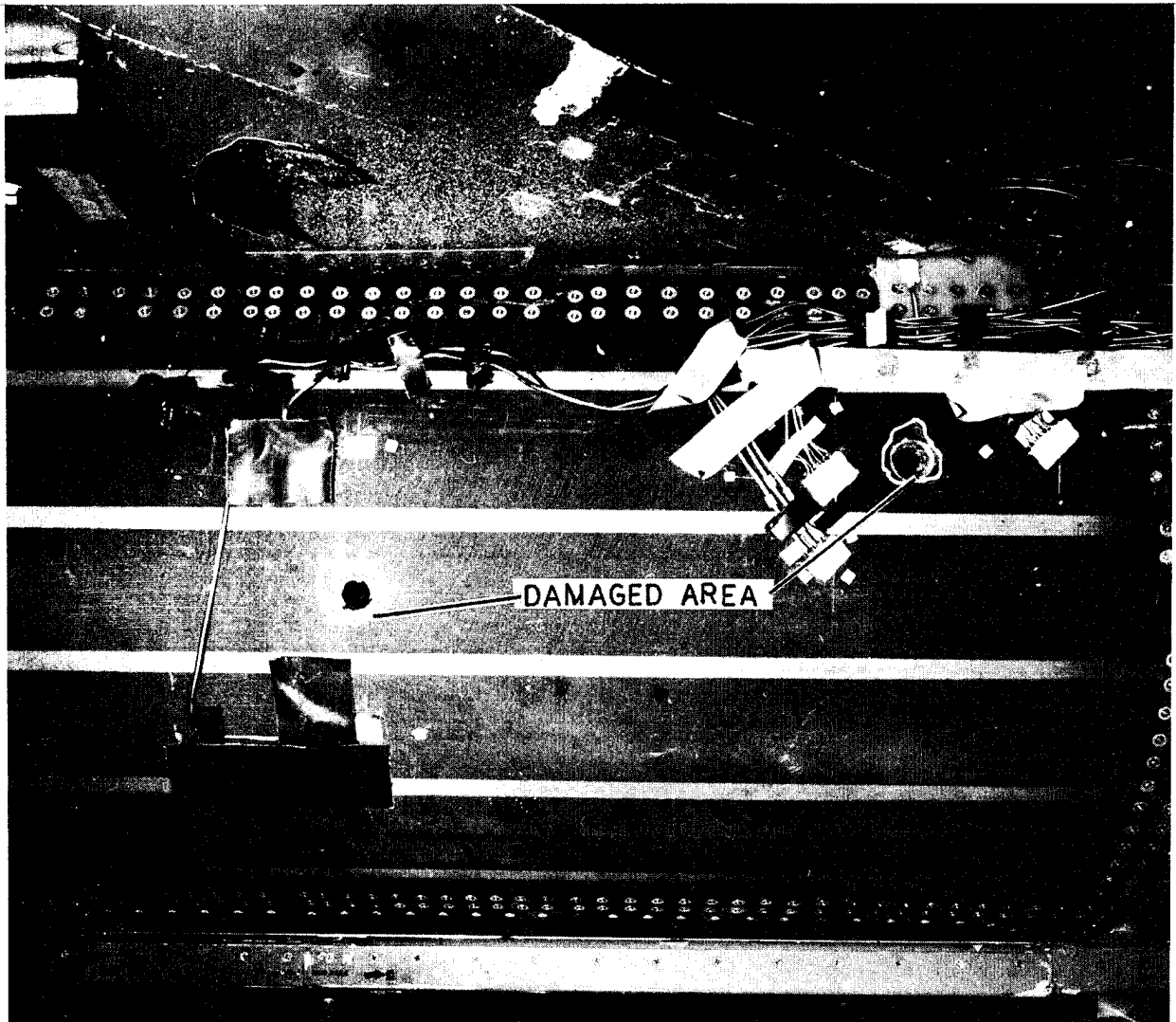

Figure 8-25. Induced Damage in Right Fuselage Panel

7.62 cm (3 in.) maximum diameter cut with a saber saw were contained at 100% DLL. Again, note that strains in the hybrid composite laminate were low, (under 1000 μ m/m) for the 5g maneuver load condition. Crack propagation may have occurred under the more critical recovery loads condition. It was decided not to switch the test assembly back to the recovery condition at this point, but to conclude the testing.

Previous testing of composite structures incorporating crack arrestment fiberglass softening strips, namely the cylinder subcomponent described in this report, demonstrated the ability of these crack arrestment features, to stop propagating cracks.

C O N C L U S I O N S

The design which was developed and demonstrated in this program resulted in a 26% reduction of the weight of the metal parts which were replaced. The cost of the design was estimated to be 20% less, in a production situation, than the metal design. The crack arrester strips which were incorporated into the fuselage section represent the first application of this concept to a primary structure design. These strips met and exceeded expectations with regard to their ability to arrest and locally contain propagating damage, both statically and ballistically induced damage. Thus, the program demonstrated and verified their feasibility, capability and practical usability as a concept for damage tolerant design. In addition, the crack arrestment testing which was performed in this program demonstrated the superior fracture tolerance characteristics of the hybrid composite material and indicated that its slow crack propagation behavior might be useful as a failure warning device for a structure.

The objectives of this program have been met and the results have been disseminated in references 13 to 16. The success experienced here with crack arrester designs has provided some impetus for work which is now being pursued in industry in conjunction with composite structures studies.

R E F E R E N C E S

1. "Fuselage Structural Analysis for BQM-34E Supersonic Aerial Target", Ryan Report No. TRA K642-13B, 20 Feb 1973 (Volumes 1 and 2).
2. "Structural Loads Report for BQM-34E Supersonic Aerial Target", Final Report, Volume 1, Basic Report, 15 July 1970.
3. "NAVAIRDEVCON Graphite-Epoxy Composite Wing for BQM-34E; Stress and Vibration Analysis", Thomas F. Neu, Shih L. Huang, Report No. NADC 73235-30, 15 November 1973.
4. "Structural Efficiency of Orthotropic Cylindrical Shells Subjected to Axial Compression", Norris F. Dow, B. Walter Rosen, AIAA Journal, March 1966.
5. "Postbuckling Behavior of Orthotropic Cylinders Under Axial Compression", B. O. Almroth, AIAA Journal, October, 1964.
6. "Compressive Buckling of Simply Supported Curved Plates and Cylinders of Sandwich Construction", Manuel Stein, J. Mayers, NACA TN 2601, January 1952.
7. "Stability of Orthotropic Cylindrical Shells Under Combined Loading", T. E. Hess, American Rocket Society Journal, 1961.
8. "Buckling of Thin-Walled Circular Cylinders", NASA SP-8007, August 1968.
9. "Structural Sandwich Composites", MIL-HDBK-23A.
10. "Fabrication and Full-Scale Structural Evaluation of Glass-Fabric Reinforced Plastic Shells", Charles W. Bert, W. C. Crisman, Gene M. Nordby, Journal of Aircraft, Jan-Feb 1968.
11. "Buckling Design Handbook", T. E. Hess.
12. "Buckling of Cylindrical and Conical Sandwich Shells with Orthotropic Facings", Charles W. Best, W. C. Crisman, Gene M. Nordby, AIAA Journal, February 1969.
13. "A Hybrid Composite Fuselage Design with Integral Crack Arresters", S. L. Huang, T. E. Hess, 3rd Conference on Fibrous Composites in Flight Vehicle Design, Williamsburg, VA, November 1975.
14. "Fracture Control in Composite Materials Using Integral Crack Arresters", T. E. Hess, S. L. Huang, H. Rubin, AIAA/ASME/SAE 17th Structures, Structural Dynamics and Materials Conference, Valley Forge, May 1976.
15. "Fracture Control in Composite Materials Using Integral Crack Arresters", T. E. Hess, S. L. Huang, H. Rubin, Journal of Aircraft (To Be Published).
16. "Fatigue and Fracture Control of Graphite/Epoxy Composite Laminates with Stress Raiser", S. L. Huang, T. E. Hess, M. S. Rosenfeld, International Conference on Fracture Mechanics and Technology, Hong Kong, March, 1977.

NADC-77149-30

THIS PAGE INTENTIONALLY LEFT BLANK

NADC-77149-30

APPENDIX A

NASTRAN BULK DATA

BQM-34E COMPOSITE FUSELAGE FINE GRID MODEL
FREE FLIGHT-5G

CARD COUNT	S O R T E D B U L K D A T A E C H O																	
	1	2	3	4	5	6	7	8	9	10	11	12	13	14	15	16	17	18
1-	CBAR	1001	31	14	16	15												2
2-	CBAR	1002	31	13	14	15												2
3-	CBAR	1003	37	16	15	13												2
4-	CBAR	1004	32	7	13	6												2
5-	CBAR	1005	31	13	15	11												2
6-	CBAR	1006	35	6	7	13												2
7-	CBAR	1007	31	12	13	11												2
8-	CBAR	1008	31	10	15	9												2
9-	CBAR	1009	34	15	9	10												2
10-	CBAR	1010	32	11	12	13												2
11-	CBAR	1011	33	10	11	15												2
12-	CBAR	1012	31	9	10	15												2
13-	CBAR	1013	34	2	9	15												2
14-	CBAR	1014	38	1	2	16												2
15-	CBAR	1015	31	10	4	11												2
16-	CBAR	1016	36	5	24	11												2
17-	CBAR	1017	36	4	5	11												2
18-	CBAR	1018	36	3	4	10												2
19-	CBAR	1019	36	2	3	9												2
20-	CBAR	1020	35	7	8	14												2
21-	CBAR	1021	31	6	12	11												2
22-	CBAR	1022	16	51	52	41												2
23-	+76																	176
24-	CBAR	1023	16	71	51	50												2
25-	+77																	177
26-	CBAR	1024	16	101	71	96												2
27-	+78																	178
28-	CBAR	1025	16	131	101	126												2
29-	+79																	179
30-	CBAR	1026	16	133	131	132												2
31-	+80																	180
32-	CBAR	1027	16	134	133	170												2
33-	+81																	181
34-	CBAR	1028	17	18	8	19												2
35-	CBAR	1029	17	39	18	21												2
36-	CBAR	1030	18	19	17	14												2
37-	CBAR	1031	39	38	39	42												2
38-	CBAR	1032	40	42	41	38												2
39-	CBAR	1033	41	38	41	37												2
40-	CBAR	1034	42	37	38	41												2
41-	CBAR	1035	43	41	37	38												2
42-	CBAR	1036	44	41	40	37												2
43-	CBAR	1037	41	37	40	36												2
44-	CBAR	1038	45	36	56	40												2
45-	CBAR	1039	46	40	36	37												2
46-	CBAR	1041	45	56	37	40												2
47-	CBAR	1042	10	69	68	73												2
48-	CBAR	1043	10	68	67	73												2
49-	CBAR	1045	10	99	98	104												2
50-	CBAR	1046	40	98	97	104												2

S O R T E D B U L K D A T A E C H O													
CARD COUNT	1	2	3	4	5	6	7	8	9	10			
51-	CBAR	1048	10	129	128	138			2	166			
52-	CBAR	1049	10	128	127	138			2	167			
53-	CBAR	1050	18	21	19	20			2				
54-	CBAR	1051	51	159	170	168			2	1512			
55-	+512			0.122	8.05	0.0	0.25	16.96	0.0				
56-	CBAR	1052	57	158	159	170			2				
57-	CBAR	1053	50	170	167	168			2				
58-	CBAR	1054	57	157	158	168			2				
59-	CBAR	1055	52	168	167	157			2				
60-	CBAR	1056	62	167	164	166			2				
61-	CBAR	1057	51	167	166	157			2				
62-	CBAR	1058	58	156	140	167			2				
63-	CBAR	1059	51	156	166	165			2				
64-	CBAR	1060	53	166	165	156			2				
65-	CBAR	1061	54	164	165	166			2				
66-	CBAR	1062	54	165	155	156			2				
67-	CBAR	1063	59	155	156	165			2				
68-	CBAR	1064	63	164	163	155			2				
69-	CBAR	1065	59	154	155	163			2				
70-	CBAR	1066	54	163	154	155			2				
71-	CBAR	1067	63	163	162	153			2				
72-	CBAR	1068	60	153	154	163			2				
73-	CBAR	1069	54	162	153	154			2				
74-	CBAR	1070	63	162	161	152			2				
75-	CBAR	1071	60	152	153	162			2				
76-	CBAR	1072	55	161	152	153			2				
77-	CBAR	1073	64	161	168	152			2				
78-	CBAR	1074	61	151	152	161			2				
79-	CBAR	1075	56	160	151	153			2				
80-	CBAR	1076	52	167	157	168			2				
81-	CBAR	1077	78	1	31	16			2	17			
82-	*7				.422		.422						
83-	CBAR	1078	70	31	61	16			2	18			
84-	*8				.422		.422						
85-	CBAR	1079	70	61	91	16			2	19			
86-	*9				.422		.422						
87-	CBAR	1080	78	91	121	16			2	110			
88-	*10				.422		.422						
89-	CBAR	1081	78	121	151	16			2	111			
90-	*11				.422		.422						
91-	CBAR	1082	5	70	22	16			2	115			
92-	CBAR	1083	5	100	70	16			2	117			
93-	CBAR	1084	5	130	100	16			2	118			
94-	CBAR	1085	5	23	130	16			2	119			
95-	CBAR	1086	19	20	14	1			2				
96-	CBAR	1087	19	42	20	1			2				
97-	CBAR	1088	19	8	17	170			2				
98-	CBAR	1090	20	39	21	170			2				
99-	CBAR	1091	19	17	14	170			2				
100-	CBAR	1093	28	21	42	170			2				

S O R T E D B U L K D A T A E C H O																
CARD	1	2	3	4	5	6	7	8	9	10	11	12	13	14	15	
101-	CBAR	1094	94	22	39	16									2	196
102-	CBAR	1095	94	159	23	16									2	197
103-	CBAR	1096	205	43	29	0.0	1.	0.0							1	
104-	CBAR	1097	215	29	59	0.0	1.	0.0							1	
105-	CBAR	1099	214	59	89	0.0	1.	0.0							1	
106-	CBAR	1101	213	89	119	0.0	1.	0.0							1	
107-	CBAR	1103	212	119	137	0.0	1.	0.0							1	
108-	CBAR	1104	202	149	148	0.0	1.	0.0							1	
109-	CBAR	1105	185	74	21	22									2	
110-	CBAR	1106	185	105	74	70									2	
111-	CBAR	1107	107	139	185	100									2	
112-	CBAR	1108	188	169	139	23									2	
113-	CBAR	1189	36	24	6	15									2	
114-	CBAR	1110	204	30	43	0.0	1.	0.0							1	
115-	CBAR	1114	201	148	150	0.0	1.	0.0							1	
116-	CBAR	1115	115	73	68	69									2	
117-	CBAR	1116	115	74	73	69									2	
118-	CBAR	1117	115	104	98	99									2	
119-	CBAR	1118	115	105	104	99									2	
120-	CBAR	1119	115	138	128	129									2	
121-	CBAR	1120	115	139	138	129									2	
122-	CBAR	1121	121	67	56	0.0	1.0	0.0							1	
123-	CBAR	1122	121	67	97	0.0	1.0	0.0							1	
124-	CBAR	1123	121	97	127	0.0	1.0	0.0							1	
125-	CBAR	1124	122	127	140	0.0	1.0	0.0							1	
126-	CBAR	1125	58	140	157	167									2	
127-	CBAR	1126	126	2	32	1.0	.0	.0							1	
128-	CBAR	1127	126	32	62	1.0	.0	.0							1	
129-	CBAR	1128	126	62	92	1.0	.0	.0							1	
130-	CBAR	1129	126	92	122	1.0	.0	.0							1	
131-	CBAR	1130	126	122	152	1.0	.0	.0							1	
132-	CBAR	1138	211	137	149	0.0	1.	0.0							1	
133-	CBAR	1139	139	75	4	.0	-1.0	.0							1	
134-	CBAR	1140	140	75	76	80									2	
135-	CBAR	1141	140	76	77	80									2	
136-	CBAR	1142	140	77	78	80									2	
137-	CBAR	1143	140	78	79	80									2	
138-	CBAR	1144	140	79	80	1.0	.0	.8							1	
139-	CBAR	1145	70	151	141	16									2	C145
140-	+C145			.422			.422									
141-	CBAR	1146	146	154	144	.0	-1.0	.0							1	
142-	CBAR	1147	147	58	81	80									2	C147
143-	+C147			0.0	-.85	0.0	0.0	-.5							0.0	
144-	CBAR	1148	148	57	58	80									2	C148
145-	+C148			0.8	.75	0.0	0.0	-.85							0.0	
146-	CBAR	1149	148	75	57	80									2	C149
147-	+C149			0.0	.65	0.0	0.0	.75							0.0	
148-	CBAR	1152	152	144	145	179									2	
149-	CBAR	1153	152	145	146	179									2	
150-	CBAR	1154	152	146	147	179									2	

SORTED BULK DATA ECHO

CARD COUNT	1	2	3	4	5	6	7	8	9	10
151-	CBAR	1155	152	147	178	179			2	
152-	CBAR	1156	152	178	179	1.0	.0	.0	1	
153-	CELAS1	2019	2001	29	1	40	1			
154-	CELAS1	2019	2002	29	2	40	2			
155-	CELAS1	2020	2001	29	3	40	3			
156-	CELAS1	2021	2003	29	4	40	4			
157-	CELAS1	2022	2004	29	5	40	5			
158-	CELAS1	2023	2003	29	6	40	6			
159-	CELAS1	2024	2001	149	1	166	1			
160-	CELAS1	2025	2002	149	2	166	2			
161-	CELAS1	2026	2001	149	3	166	3			
162-	CELAS1	2027	2003	149	4	166	4			
163-	CELAS1	2028	2004	149	5	166	5			
164-	CELAS1	2029	2003	149	6	166	6			
165-	CONM2	143	119	2	.01	-22.	.0	.0		
166-	CONM2	144	149	2	.04	-22.	.0	.0		
167-	CONM2	147	155	2	.0155					
168-	CONM2	148	156	2	.031					
169-	CONM2	149	157	2	.0078					
170-	COR02C	1	0	0.0	0.0	0.0	0.0	0.0	1.0	11
171-	*1	8.8	1.0	0.0						
172-	COR02R	2	0	.0	6.0	0.0	0.0	6.0	1.0	185
173-	*85	1.0	6.0	0.0						
174-	CQUAD1	200	200	60	30	43	55	.0		
175-	CQUAD1	201	201	55	43	29	59	.0		
176-	CQUAD1	202	202	90	60	55	87	.0		
177-	CQUAD1	203	203	87	55	59	89	.0		
178-	CQUAD1	204	204	120	90	87	117	.0		
179-	CQUAD1	205	205	117	87	89	119	.0		
180-	CQUAD1	206	206	135	120	117	136	.0		
181-	CQUAD1	207	207	136	117	119	137	.0		
182-	CQUAD1	208	208	150	135	136	148	.0		
183-	CQUAD1	209	209	148	136	137	149	.0		
184-	CROD	890	119	18	19	920	119	19	20	
185-	CSHEAR	143	118	18	8	17	19			
186-	CSHEAR	144	118	39	18	19	21			
187-	CSHEAR	145	118	19	17	14	20			
188-	CSHEAR	146	118	21	19	20	42			
189-	CTRIA1	15	47	1	31	2				
190-	CTRIA1	16	47	32	2	31				
191-	CTRIA1	17	47	2	32	3				
192-	CTRIA1	18	47	33	3	32				
193-	CTRIA1	19	47	3	33	44				
194-	CTRIA1	20	47	34	4	44				
195-	CTRIA1	21	47	4	34	45				
196-	CTRIA1	22	47	35	5	45				
197-	CTRIA1	23	47	5	35	25				
198-	CTRIA1	44	47	31	61	32				
199-	CTRIA1	45	47	62	32	61				
200-	CTRIA1	46	47	32	62	33				

S O R T E D B U L K D A T A E C H O														
CARD COUNT	1	2	3	4	5	6	7	8	9	10				
201-	CTRIA1	47	47	63	33	62								
202-	CTRIA1	48	3	33	63	49								
203-	CTRIA1	49	3	64	34	49								
204-	CTRIA1	50	3	34	64	53								
205-	CTRIA1	51	3	65	35	53								
206-	CTRIA1	52	47	35	65	54								
207-	CTRIA1	53	47	66	36	54								
208-	CTRIA1	66	47	61	91	62								
209-	CTRIA1	67	47	92	62	91								
210-	CTRIA1	68	47	62	92	63								
211-	CTRIA1	69	47	93	63	92								
212-	CTRIA1	70	3	63	93	64								
213-	CTRIA1	71	3	94	64	93								
214-	CTRIA1	72	3	64	94	65								
215-	CTRIA1	73	3	95	65	94								
216-	CTRIA1	74	47	65	95	66								
217-	CTRIA1	75	47	96	66	95								
218-	CTRIA1	86	47	91	121	92								
219-	CTRIA1	87	47	122	92	121								
220-	CTRIA1	88	47	92	122	93								
221-	CTRIA1	89	47	123	93	122								
222-	CTRIA1	90	3	93	123	94								
223-	CTRIA1	91	3	124	94	123								
224-	CTRIA1	92	3	94	124	95								
225-	CTRIA1	93	3	125	95	124								
226-	CTRIA1	94	47	95	125	96								
227-	CTRIA1	95	47	126	96	125								
228-	CTRIA1	106	47	121	151	122								
229-	CTRIA1	107	47	151	152	122								
230-	CTRIA1	108	47	123	122	152	90.							
231-	CTRIA1	109	47	152	153	123	90.							
232-	CTRIA1	110	47	124	123	153	90.							
233-	CTRIA1	111	47	153	154	124	90.							
234-	CTRIA1	112	47	125	124	154	90.							
235-	CTRIA1	113	47	154	155	125	90.							
236-	CTRIA1	114	47	126	125	155	90.							
237-	CTRIA1	115	47	156	126	155								
238-	CTRIA1	152	47	35	36	25	90.							
239-	CTRIA1	170	47	4	3	44	90.							
240-	CTRIA1	171	47	33	34	44	90.							
241-	CTRIA1	172	47	5	4	45	90.							
242-	CTRIA1	173	47	34	35	45	90.							
243-	CTRIA1	179	3	34	33	49	90.							
244-	CTRIA1	180	3	63	64	49	90.							
245-	CTRIA1	181	3	35	34	53	90.							
246-	CTRIA1	182	3	64	65	53	90.							
247-	CTRIA1	183	47	36	35	54	90.							
248-	CTRIA1	184	47	65	66	54	90.							
249-	CTRIA2	1	1	14	13	8								
250-	CTRIA2	2	1	13	7	8								

S O R T E D B U L K D A T A E C H O													
CARD	1	2	3	4	5	6	7	8	9	10			
COUNT
251-	CTRIA2	3	1	13	6	7							
252-	CTRIA2	4	1	16	15	14							
253-	CTRIA2	5	1	13	14	15							
254-	CTRIA2	6	1	15	11	13							
255-	CTRIA2	7	1	6	13	11							
256-	CTRIA2	8	1	11	5	6							
257-	CTRIA2	9	1	10	4	11							
258-	CTRIA2	10	1	5	11	4							
259-	CTRIA2	11	1	11	15	9							
260-	CTRIA2	12	1	4	10	3							
261-	CTRIA2	13	1	10	9	3							
262-	CTRIA2	14	1	3	9	2							
263-	CTRIA2	24	67	36	6	25							
264-	CTRIA2	25	67	56	37	6	90.						
265-	CTRIA2	26	67	37	46	6							
266-	CTRIA2	27	67	38	7	47							
267-	CTRIA2	28	67	7	38	48							
268-	CTRIA2	29	67	39	8	48							
269-	CTRIA2	30	14	14	13	42							
270-	CTRIA2	31	14	41	42	13							
271-	CTRIA2	32	14	13	12	41							
272-	CTRIA2	33	14	40	41	12							
273-	CTRIA2	34	14	36	40	12							
274-	CTRIA2	35	14	12	6	36							
275-	CTRIA2	36	14	51	52	42							
276-	CTRIA2	37	14	42	41	51							
277-	CTRIA2	38	14	50	51	41							
278-	CTRIA2	39	14	41	40	50							
279-	CTRIA2	40	2	39	42	38							
280-	CTRIA2	41	2	42	41	38							
281-	CTRIA2	42	22	41	40	37							
282-	CTRIA2	43	22	40	36	56							
283-	CTRIA2	54	4	67	68	36							
284-	CTRIA2	55	4	37	56	68							
285-	CTRIA2	56	4	68	69	37							
286-	CTRIA2	57	4	69	38	37							
287-	CTRIA2	58	4	38	69	70							
288-	CTRIA2	59	4	70	39	38							
289-	CTRIA2	60	14	40	36	72							
290-	CTRIA2	61	14	40	72	61							
291-	CTRIA2	62	14	51	50	71							
292-	CTRIA2	63	14	72	71	50							
293-	CTRIA2	64	14	71	72	101							
294-	CTRIA2	65	14	102	101	72							
295-	CTRIA2	76	4	67	97	98							
296-	CTRIA2	77	4	98	68	67							
297-	CTRIA2	78	4	68	98	99							
298-	CTRIA2	79	4	99	69	68							
299-	CTRIA2	80	4	69	99	100							
300-	CTRIA2	81	4	100	70	69							

S O R T E D B U L K D A T A E C H O										
CARD COUNT	1	2	3	4	5	6	7	8	9	10
301-	CTRIA2	82	14	101	102	131				
302-	CTRIA2	83	14	103	131	102				
303-	CTRIA2	84	14	132	133	131				
304-	CTRIA2	85	14	131	103	132				
305-	CTRIA2	96	4	97	127	128				
306-	CTRIA2	97	4	128	98	97				
307-	CTRIA2	98	4	98	128	129				
308-	CTRIA2	99	4	129	99	98				
309-	CTRIA2	100	4	99	129	130				
310-	CTRIA2	101	4	130	102	99				
311-	CTRIA2	102	14	134	133	170				
312-	CTRIA2	103	14	167	170	133				
313-	CTRIA2	104	14	133	132	167				
314-	CTRIA2	105	14	165	167	132				
315-	CTRIA2	116	11	159	169	158				
316-	CTRIA2	117	11	169	168	158				
317-	CTRIA2	118	11	168	157	158				
318-	CTRIA2	119	11	168	169	170				
319-	CTRIA2	120	11	170	167	168				
320-	CTRIA2	121	11	157	168	167				
321-	CTRIA2	122	11	166	156	140				
322-	CTRIA2	123	11	166	167	164				
323-	CTRIA2	124	11	164	165	166				
324-	CTRIA2	125	11	156	166	165				
325-	CTRIA2	126	11	165	155	156				
326-	CTRIA2	127	11	155	164	163				
327-	CTRIA2	128	11	163	154	155				
328-	CTRIA2	129	11	154	163	162				
329-	CTRIA2	130	11	162	153	154				
330-	CTRIA2	131	21	153	162	161				
331-	CTRIA2	132	21	161	152	153				
332-	CTRIA2	133	21	152	161	160				
333-	CTRIA2	134	21	160	151	152				
334-	CTRIA2	135	4	156	157	127				
335-	CTRIA2	136	4	128	127	157				
336-	CTRIA2	137	4	157	158	128				
337-	CTRIA2	138	4	129	128	158				
338-	CTRIA2	139	4	158	159	129				
339-	CTRIA2	140	4	159	130	129				
340-	CTRIA2	141	14	126	166	103				
341-	CTRIA2	142	14	156	166	126				
342-	CTRIA2	143	220	158	178	179				
343-	CTRIA2	144	220	179	159	158				
344-	CTRIA2	147	14	103	166	132				
345-	CTRIA2	148	14	126	103	96				
346-	CTRIA2	149	14	102	96	103				
347-	CTRIA2	150	67	25	24	5				
348-	CTRIA2	151	67	24	25	6				
349-	CTRIA2	153	14	96	102	66				
350-	CTRIA2	154	14	72	66	102				

SORTED BULK DATA ECHO

CARD COUNT	1	2	3	4	5	6	7	8	9	10
351-	CTRIA2	155	14	36	66	72				
352-	CTRIA2	156	22	40	37	56				
353-	CTRIA2	157	67	6	36	56				
354-	CTRIA2	158	7	16	81	15				
355-	CTRIA2	159	7	58	15	81				
356-	CTRIA2	160	7	15	58	10				
357-	CTRIA2	161	7	57	10	58				
358-	CTRIA2	162	7	10	57	4				
359-	CTRIA2	163	7	75	4	57				
360-	CTRIA2	164	11	140	157	167				
361-	CTRIA2	165	11	167	156	140				
362-	CTRIA2	174	67	46	37	47				
363-	CTRIA2	175	67	7	46	47	90.			
364-	CTRIA2	176	67	37	38	47	90.			
365-	CTRIA2	177	67	8	7	48	90.			
366-	CTRIA2	178	67	38	39	48	90.			
367-	CTRIA2	185	185	39	21	22				
368-	CTRIA2	186	186	21	74	22				
369-	CTRIA2	187	187	74	70	22				
370-	CTRIA2	188	187	70	74	105				
371-	CTRIA2	189	187	105	100	70				
372-	CTRIA2	190	187	100	105	139				
373-	CTRIA2	191	187	139	130	100				
374-	CTRIA2	192	187	130	139	169				
375-	CTRIA2	193	193	169	159	130				
376-	CTRIA2	194	5	75	4	76				
377-	CTRIA2	195	5	5	76	4				
378-	CTRIA2	196	5	76	5	24				
379-	CTRIA2	197	5	77	76	24				
380-	CTRIA2	198	5	6	77	24				
381-	CTRIA2	199	5	77	6	46				
382-	CTRIA2	200	5	46	78	77				
383-	CTRIA2	201	5	78	46	7				
384-	CTRIA2	202	5	7	79	78				
385-	CTRIA2	203	5	79	7	8				
386-	CTRIA2	204	5	8	80	79				
387-	CTRIA2	205	6	151	141	152				
388-	CTRIA2	206	6	142	152	141				
389-	CTRIA2	207	6	152	142	153				
390-	CTRIA2	208	6	143	153	142				
391-	CTRIA2	209	6	153	154	143				
392-	CTRIA2	210	6	144	154	143				
393-	CTRIA2	211	220	154	144	155				
394-	CTRIA2	212	220	145	155	144				
395-	CTRIA2	213	220	155	145	156				
396-	CTRIA2	214	220	146	156	145				
397-	CTRIA2	215	220	140	156	146				
398-	CTRIA2	216	220	146	147	140				
399-	CTRIA2	217	220	147	157	140				
400-	CTRIA2	218	220	157	147	178				

SORTED BULK DATA ECHO

CARD COUNT	1	2	3	4	5	6	7	8	9	10
401-	CTRIA2	219	220	178	158	157				
402-	CTRIA2	220	220	73	68	67				
403-	CTRIA2	221	220	68	73	69				
404-	CTRIA2	222	220	73	74	69				
405-	CTRIA2	223	220	74	70	69				
406-	CTRIA2	224	220	104	98	97				
407-	CTRIA2	225	220	98	104	99				
408-	CTRIA2	225	220	104	105	99				
409-	CTRIA2	227	220	105	100	99				
410-	CTRIA2	228	220	138	128	127				
411-	CTRIA2	229	220	128	138	129				
412-	CTRIA2	230	220	138	139	129				
413-	CTRIA2	231	220	139	130	129				
414-	FORCE	1	57	0	1000.	.0	.0	.454		
415-	FORCE	1	58	0	1000.	.0	.0	.454		
416-	FORCE	1	75	0	1000.	.0	-.527	7.95		
417-	FORCE	1	76	0	1000.	.0	-.486	2.5		
418-	FORCE	1	77	0	1000.	.0	-.728	-.26		
419-	FORCE	1	78	0	1000.	.0	-.604	-3.266		
420-	FORCE	1	79	0	1000.	.0	-.480	-5.226		
421-	FORCE	1	80	0	1000.	.0	-.050	-3.595		
422-	FORCE	1	81	0	1000.	.0	.0	.454		
423-	FORCE	1	141	0	1000.	.0	-.113	-.953		
424-	FORCE	1	142	0	1000.	.0	-.344	-.488		
425-	FORCE	1	143	0	1000.	.0	-.394	-.263		
426-	FORCE	1	144	0	1000.	.0	-.921	-.26		
427-	FORCE	1	145	0	1000.	.0	-.794	.044		
428-	FORCE	1	146	0	1000.	.0	-.422	.189		
429-	FORCE	1	147	0	1000.	.0	-.283	.290		
430-	FORCE	1	178	0	1000.	.0	-.235	.341		
431-	FORCE	1	179	0	1000.	.0	-.188	.172		
432-	GRAV	2	0	386.4	0.0	-9.25	-2.32			
433-	GRID	1	1	12.5	180.0	0.0	1			
434-	GRID	2	1	12.5	148.5	0.0	1			
435-	GRID	3	1	12.5	119.0	0.0	1			
436-	GRID	4	1	12.5	98.0	0.0	1			
437-	GRID	5	1	12.5	90.0	0.0	1			
438-	GRID	6	1	12.5	61.0	0.0	1			
439-	GRID	7	1	12.5	22.0	0.0	1			
440-	GRID	8	1	12.5	.0	0.0	1			
441-	GRID	9	1	10.75	122.5	0.0	1			
442-	GRID	10	1	8.73	101.5	0.0	1			
443-	GRID	11	1	9.06	90.0	0.0	1			
444-	GRID	12	1	10.87	56.5	0.0	1			
445-	GRID	13	1	7.28	34.5	0.0	1			
446-	GRID	14	1	6.0	.0	0.0	1			
447-	GRID	15	1	4.12	90.0	0.0	1			
448-	GRID	16	1	.0	.0	0.0	1			
449-	GRID	17	2	.0	3.25	.0	2			
450-	GRID	18	2	.0	6.5	4.25	2			

S O R T E D B U L K D A T A E C H O													
CARD COUNT	1	2	3	4	5	6	7	8	9	10			
451-	GRID	19	2	.0	3.25	4.25	2						
452-	GRID	20	2	.0	.0	4.25	2						
453-	GRID	21	2	.00	3.25	8.5	2						
454-	GRID	22	1	12.5	.0	11.5	1						
455-	GRID	23	1	12.5	0.0	39.6	1						
456-	GRID	24	1	12.5	75.5	.0	1						
457-	GRID	25	1	12.5	75.5	4.25	1						
458-	GRID	29	2	-9.0	.81	8.5	2						
459-	GRID	30	2	.0	.81	8.5	2						
460-	GRID	31	1	12.5	180.0	8.5	1						
461-	GRID	32	1	12.5	148.5	8.5	1						
462-	GRID	33	1	12.5	119.0	8.5	1						
463-	GRID	34	1	12.5	98.0	8.5	1						
464-	GRID	35	1	12.5	90.0	8.5	1						
465-	GRID	36	2	-10.96	.0	8.5	2						
466-	GRID	37	1	12.5	40.0	8.5	1						
467-	GRID	38	1	12.5	22.0	8.5	1						
468-	GRID	39	1	12.5	.0	8.5	1						
469-	GRID	40	1	10.82	56.3	8.5	2						
470-	GRID	41	1	7.5	38.0	8.5	1						
471-	GRID	42	1	6.0	.0	8.5	1						
472-	GRID	43	2	-4.5	.81	8.5	2						
473-	GRID	44	1	12.5	108.5	4.25	1						
474-	GRID	45	1	12.5	94.0	4.25	1						
475-	GRID	46	1	12.5	40.0	.0	1						
476-	GRID	47	1	12.5	31.0	4.25	1						
477-	GRID	48	1	12.5	11.0	4.25	1						
478-	GRID	49	1	12.5	108.5	12.5	1						
479-	GRID	58	2	-7.625	.0	12.0	2				5		
480-	GRID	51	2	-4.625	.0	12.0	2						
481-	GRID	52	2	.0	.0	12.0	2						
482-	GRID	53	1	12.5	94.0	12.5	1						
483-	GRID	54	1	12.5	75.5	12.5	1						
484-	GRID	55	2	-4.5	.81	16.5	2				5		
485-	GRID	56	1	12.5	51.5	8.5	1						
486-	GRID	57	1	8.73	101.5	-8.5	2						
487-	GRID	58	1	4.12	90.0	-8.5	2						
488-	GRID	59	2	-9.0	.81	16.5	2				5		
489-	GRID	60	2	.0	.81	16.5	2						
490-	GRID	61	1	12.5	180.0	16.5	1						
491-	GRID	62	1	12.5	148.5	16.5	1						
492-	GRID	63	1	12.5	119.0	16.5	1						
493-	GRID	64	1	12.5	98.0	16.5	1						
494-	GRID	65	1	12.5	90.0	16.5	1						
495-	GRID	66	2	-10.96	.0	16.5	2						
496-	GRID	67	1	12.5	51.5	17.5	2						
497-	GRID	68	1	12.5	33.7	17.5	1						
498-	GRID	69	1	12.5	22.	17.5	0						
499-	GRID	70	1	12.5	0.0	17.5	1						
500-	GRID	71	2	-7.625	.0	16.5	2						

SORTED BULK DATA ECHO

CARD COUNT	1	2	3	4	5	6	7	8	9	10
501-	GRID	72	2	-9.0	.0	16.5	2	5		
502-	GRID	73	2	-4.55	4.40	17.5	2			
503-	GRID	74	1	10.40	.0	17.5	1			
504-	GRID	75	1	12.5	98.0	-8.5	2			
505-	GRID	76	1	12.5	90.0	-8.5	1			
506-	GRID	77	1	12.5	61.0	-8.5	1			
507-	GRID	78	1	12.5	40.0	-8.5	1			
508-	GRID	79	1	12.5	22.0	-8.5	1			
509-	GRID	80	1	12.5	.0	-8.5	1			
510-	GRID	81	1	.0	.0	-8.5	2			
511-	GRID	87	2	-4.5	.81	24.84	2	5		
512-	GRID	89	2	-9.0	.81	24.84	2	5		
513-	GRID	90	2	.0	.81	24.84	2			
514-	GRID	91	1	12.5	180.0	24.84	1			
515-	GRID	92	1	12.5	148.5	24.84	1			
516-	GRID	93	1	12.5	119.0	24.84	1			
517-	GRID	94	1	12.5	98.0	24.84	1			
518-	GRID	95	1	12.5	90.0	24.84	1			
519-	GRID	96	2	-10.96	.0	24.84	2			
520-	GRID	97	1	12.5	51.5	24.84	2			
521-	GRID	98	1	12.5	35.71	24.84	1			
522-	GRID	99	1	12.5	22.	24.84	0			
523-	GRID	100	1	12.5	0.0	24.84	1			
524-	GRID	101	2	-7.625	.0	24.84	2			
525-	GRID	102	2	-9.0	.0	24.84	2	5		
526-	GRID	103	2	-9.0	.0	33.1	2	5		
527-	GRID	104	2	-4.55	4.15	24.84	2			
528-	GRID	105	1	10.15	.0	24.84	1			
529-	GRID	117	2	-4.5	.81	33.1	2	5		
530-	GRID	119	2	-9.0	.81	33.1	2	5		
531-	GRID	120	2	.0	.81	33.1	2			
532-	GRID	121	1	12.5	180.0	33.1	1			
533-	GRID	122	1	12.5	148.5	33.1	1			
534-	GRID	123	1	12.5	119.0	33.1	1			
535-	GRID	124	1	12.5	98.0	33.1	1			
536-	GRID	125	1	12.5	90.0	33.1	1			
537-	GRID	126	2	-10.96	.0	33.1	2			
538-	GRID	127	1	12.5	51.5	31.1	2			
539-	GRID	128	1	12.5	37.25	31.1	1			
540-	GRID	129	1	12.5	22.	31.1	0			
541-	GRID	130	1	12.5	0.0	31.1	1			
542-	GRID	131	2	-7.625	.0	33.1	2			
543-	GRID	132	2	-7.625	.0	38.1	2	5		
544-	GRID	133	2	-4.5	.0	38.1	2			
545-	GRID	134	2	.0	.0	38.1	2			
546-	GRID	135	2	.0	.81	38.1	2			
547-	GRID	136	2	-4.5	.81	38.1	2	5		
548-	GRID	137	2	-9.0	.81	38.1	2	5		
549-	GRID	138	2	-4.55	3.95	31.1	2			
550-	GRID	139	1	9.95	.0	31.1	1			

SORTED BULK DATA ECHO

CARD		1	2	3	4	5	6	7	8	9	10
551-	GRID	140	1		12.5	51.5	41.1	1			
552-	GRID	141	1		12.5	180.0	51.9	1			
553-	GRID	142	1		12.5	144.0	51.9	1			
554-	GRID	143	1		12.5	124.0	51.9	1			
555-	GRID	144	1		12.5	100.0	51.9	1			
556-	GRID	145	1		12.5	84.0	51.9	1			
557-	GRID	146	2		-10.96	.0	51.9	1			
558-	GRID	147	1		12.5	40.0	51.9	1			
559-	GRID	148	2		-4.5	.81	41.1	2			
560-	GRID	149	2		-9.0	.81	41.1	2			
561-	GRID	150	2		.0	.81	41.1	2			
562-	GRID	151	1		12.5	180.0	42.1	1			
563-	GRID	152	1		12.5	144.0	41.959	1			
564-	GRID	153	1		12.5	124.0	41.803	1			
565-	GRID	154	1		12.5	100.0	41.334	1			
566-	GRID	155	1		12.5	84.0	41.256	1			
567-	GRID	156	2		-10.96	.0	41.1	1			
568-	GRID	157	1		12.5	40.0	41.1	1			
569-	GRID	158	1		12.5	19.5	41.1	1			
570-	GRID	159	1		12.5	.0	41.1	1			
571-	GRID	160	1		10.0	180.0	41.959	1			
572-	GRID	161	1		9.5	144.0	41.878	1			
573-	GRID	162	1		9.0	125.5	41.75	1			
574-	GRID	163	1		8.0	100.0	41.3	1			
575-	GRID	164	1		7.54	77.5	41.256	1			
576-	GRID	165	1		7.52	80.0	41.256	1			
577-	GRID	166	1		10.82	56.3	41.1	2			
578-	GRID	167	1		7.5	37.0	41.1	1			
579-	GRID	168	1		10.4	23.0	41.1	1			
580-	GRID	169	1		9.58	.0	41.1	1			
581-	GRID	170	1		6.0	.0	41.1	1			
582-	GRID	178	1		12.5	19.5	51.9	1			
583-	GRID	179	1		12.5	.0	51.9	1			
584-	LOAD	3	1.8	1.0	1	1	1.0	2			
585-	MAT1	1	1.03+7	3.9+6	.33	2.56-4					12
586-	+2	75.+3	65.+3	42.+3							
587-	MAT1	2	1.03+7	3.9+6	.33	2.6-4					13
588-	+3	77.+3	64.+3	46.+3							
589-	MAT1	3	1.03+7		.33	2.6-4					114
590-	+14	74.+3	63.+3	43.+3							
591-	MAT1	4	9.7+4	3.25+4							16
592-	+6	360.	360.	200.							
593-	MAT1	5	29.+6	12.5+6	.3	7.4-4					MTL5
594-	+TL5	75.+3	27.+3	50.+3							
595-	MAT1	10	16.0+6	6.2+6							
596-	MAT1	12	2.5+6	5.166+6		.14245-3					
597-	MAT1	14	1.03+7	3.9+6	.33	2.6-4					115
598-	+15	78.+3	69.+3	47.+3							
599-	MAT1	16	1.05+7		.33	2.58-4					184
600-	+84	61.+3	38.+3	38.+3							

S O R T E D B U L K D A T A E C H O										
CARD COUNT	1	2	3	4	5	6	7	8	9	10
601-	MAT1	117	1.01+7	3.85+6	.33	2.52-4				193
602-	+93	3.4+4	2.3+4	2.0+4						
603-	MAT1	200	3.0+4	7.0+4						SHEAR
604-	+HEAR									
605-	MAT2	7	8.6+6	.90+6		2.2+6		1.1+6	1.7-4	MTL7
606-	+TL7						50.+3	45.+3	15.+3	
607-	MAT2	8	9.9+6	.89+6		2.3+6		1.1+6	1.7-4	MTL8
608-	+TL8						50.+3	45.+3	15.+3	
609-	MAT2	9	9.2+6	.83+6		2.2+6		1.1+6		MTL9
610-	+TL9						50.+3	45.+3	15.+3	
611-	MAT2	13	7.4+6	.90+6		2.1+6		1.1+6	1.7-4	MTL13
612-	+TL13						50.+3	45.+3	15.+3	
613-	MAT2	40	2.34+6	1.291+6	0.0	1.743+7	0.8	1.6+6		
614-	MPC	1	67	2	1.0	59	2	-1.0		
615-	MPC	1	97	2	1.0	89	2	-1.0		
616-	MPC	1	127	2	1.0	119	2	-1.0		
617-	PARAM		GRDPNT	22						
618-	PBAR	5	3	.063	2.08-5	.00525	8.33-5			BAR5
619-	+AR5	.5	0.0	-.5	0.0					
620-	PBAR	10	3	.0276	3.6-6	.0011	1.47-4			BAR10
621-	+AR10	.35	0.0	-.35	0.0					
622-	PBAR	12	3	.08	6.35-3	.0114	4.27-5			172
623-	+72	0.0	0.0	-.77	-.26	0.0	.74			173
624-	+73	.417	.417							
625-	PBAR	13	3	.323	.266	.0006	4.26-4			174
626-	+74	0.0	0.0							175
627-	+75	.417	.417							
628-	PBAR	16	16	.0675	3.16-3	4.56-5	1.82-4			182
629-	+82	0.0	0.0							183
630-	+83	.834	.834							
631-	PBAR	17	117	.125	.163-4	.042	.042			187
632-	+87	0.0	0.0							188
633-	+88	.834	.834							
634-	PBAR	18	117	.25	.33	.083	.085			189
635-	+89	0.0	0.0							190
636-	+90	.834	.834							
637-	PBAR	19	117	.25	.0156	.083	.085			191
638-	+91	0.0	0.0							192
639-	+92	.834	.834							
640-	PBAR	20	117	.188	.141	.001	.141			194
641-	+94	0.0	0.0							195
642-	+95	.833	.833							
643-	PBAR	31	1	.16	4.33-3	1.44-2	5.38-4			131
644-	+31	0.0	0.0	0.0	0.275					1311
645-	+311	.416	.416							
646-	PBAR	32	1	.08	5.67-4	3.31-2	2.67-4			132
647-	+32	0.0	0.0	0.0	0.175					1321
648-	+321	.416	.416							
649-	PBAR	33	1	.16	1.43-3	4.36-3	3.73-3			133
650-	+33	0.0	0.0	0.0	0.238					1331

SORTED BULK DATA ECHO										
CARD	1	2	3	4	5	6	7	8	9	10
651-	+331	.208	.624							
652-	PBAR	34	1	.28	6.82-2	2.30-2	9.30-4			134
653-	+34	0.0	0.0	-.425	+.7	-.425	-.7			1341
654-	+341	.416	.416							
655-	PBAR	35	1	.468	.256	.20	1.56-3			135
656-	+35	0.0	0.0	-.66	1.17	-.66	-1.17			1351
657-	+351	.416	.416							
658-	PBAR	36	1	.46	.267	.19	1.53-3			136
659-	+36	0.0	0.0	-.65	1.088	-.65	-1.088			1361
660-	+361	.416	.416							
661-	PBAR	37	1	.40	.152	5.32-2	1.33-3			137
662-	+37	0.0	0.0	-.745	.995	.515	.495	1.255	-.335	1371
663-	+371	.416	.416							
664-	PBAR	38	1	1.053	1.447	.23	2.34-2			138
665-	+38	0.0	0.0	1.725	-.235	-1.	-1.685	-1.	1.415	1381
666-	+381	.216	.618							
667-	PBAR	39	2	.396	.119	.117	2.53-3			139
668-	+39	0.0	0.0	-.547	1.378	1.076	-.272			1391
669-	+391	.556	.278							
670-	PBAR	40	2	.427	.095	.078	3.02-3			140
671-	+40	0.0	0.0	-.386	1.224	1.114	-.276			1401
672-	+401	.468	.365							
673-	PBAR	41	2	.189	6.76-3	.018	7.00-4			141
674-	+41	0.0	0.0	0.0	.605	-.45	-.295			1411
675-	+411	.436	.396							
676-	PBAR	42	2	.487	.133	.137	4.20-3			142
677-	+42	0.0	0.0	-.273	1.167	1.377	-.483	.45	-.295	1421
678-	+421	.311	.523							
679-	PBAR	43	2	.279	7.30-3	.029	2.80-3			143
680-	+43	0.0	0.0	0.0	.52	.45	-.38	-.45	-.38	1431
681-	+431	.296	.538							
682-	PBAR	44	2	.202	.073	.078	1.60-3			144
683-	+44	0.0	0.0	.322	1.13	1.178	-.37			1441
684-	+441	.39	.444							
685-	PBAR	45	2	.314	.088	.076	1.01-3			145
686-	+45	0.0	0.0	-.456	1.326	1.196	-.324			1451
687-	+451	.483	.350							
688-	PBAR	46	2	.540	.078	.123	8.50-3			146
689-	+46	0.0	0.0	-.191	1.017	1.389	-.483			1461
690-	+461	.256	.579							
691-	PBAR	50	1	.256	.0192	.0595	7.16-4			150
692-	+50	0.0	0.0	0.0	1.044	.76	-.416			1501
693-	+501	.364	.453							
694-	PBAR	51	1	.072	4.6-4	.9-3	2.02-4			151
695-	+51	0.0	0.0	0.0	.362	.25	-.078			1511
696-	+511	.37	.463							
697-	PBAR	52	1	.081	6.45-4	2.185-3	2.30-4			152
698-	+52	0.0	0.0	0.0	.343	.275	-.147			1521
699-	+521	.370	.463							
700-	PBAR	53	1	.22	.009	.0317	8.22-4			153

S O R T E D B U L K D A T A E C H O										
CARD COUNT	1	2	3	4	5	6	7	8	9	10
701-	+53	0.0	0.0	0.0	1.129	.61	-.354			1531
702-	+531	.33	.5							
703-	PBAR	54	1	.159	.008	.0199	3.02-4			154
704-	+54	0.0	0.0	0.0	.634	.57	-.266			1541
705-	+541	.444	.389							
706-	PBAR	55	1	.17	.088	.218	3.60-4			155
707-	+55	0.0	0.0	0.0	.815	.57	-.285			1551
708-	+551	.416	.416							
709-	PBAR	56	1	.131	2.65-3	3.54-3	3.67-4			156
710-	+56	0.0	0.0	0.0	0.72	.41	-.05			1561
711-	+561	.372	.464							
712-	PBAR	57	1	.342	.13	.057	9.58-4			157
713-	+57	0.0	0.0	1.505	0.0	-.445	.99	-.455	-.99	1571
714-	+571	.37	.463							
715-	PBAR	58	1	.33	.085	.0209	5.38-3			158
716-	+58	0.0	0.0	.852	0.0	-.273	.5	-.273	-.5	1581
717-	+581	.202	.531							
718-	PBAR	59	1	.799	.359	.259	.013			159
719-	+59	0.0	0.0	2.221	0.0	-.324	1.21	-.324	-1.21	1591
720-	+591	.202	.631							
721-	PBAR	60	1	.436	.266	.118	1.22-3			160
722-	+60	0.0	0.0	1.91	0.0	-.56	1.21	-.56	-1.21	1601
723-	+601	.37	.462							
724-	PBAR	61	1	.311	.099	.0432	8.72-4			161
725-	+61	0.0	0.0	1.37	0.0	-.467	.865	-.407	-.865	1611
726-	+611	.371	.464							
727-	PBAR	62	1	.176	.0252	.0103	4.63-4			162
728-	+62	0.0	0.0	.75	-.168	-.54	-.168	-.18	.562	1621
729-	+621	.489	.346							
730-	PBAR	63	1	.212	.0285	.0587	1.04-3			163
731-	+63	0.0	0.0	.776	-.198	-.504	-.198	-.154	.532	1631
732-	+631	.406	.430							
733-	PBAR	64	1	.249	.034	.0154	2.19-3			164
734-	+64	0.0	0.0	.798	-.226	-.492	-.226	-.132	.544	1641
735-	+641	.345	.489							
736-	PBAR	70	2	.324	.07		.0012			112
737-	+12	0.0	0.0	-.778	1.0	.422	0.0	.422	1.75	113
738-	+13	.474	.36							
739-	PBAR	72	14	.2	1.6-4	6.67-2	6.7-2			1172
740-	+172	.05	0.	-.05	0.	0.	1.0	0.	-1.0	
741-	PBAR	73	14	.5	2.6-3	.167	.169			1173
742-	+173	.125	0.	-.125	0.	0.	1.0	0.	-1.0	
743-	PBAR	94	3	.190	5.7-4	.0158	2.29-3			BAR94
744-	+AR94	.5	0.0	-.5	0.0					
745-	PBAR	105	3	.072	2.39-5	.008	9.57-5			BAR105
746-	+AR105	.57	0.0	-.57	0.0					
747-	PBAR	106	3	.089	2.95-5	.015	1.18-4			BAR106
748-	+AR106	.71	0.0	-.71	0.0					
749-	PBAR	107	3	.098	3.22-5	.0196	1.29-4			BAR107
750-	+AR107	.78	0.0	-.78	0.0					

SORTED BULK DATA ECHO

CARD COUNT	1	2	3	4	5	6	7	8	9	10
751-	PBAR	108	3	.116	3.85-5	.0332	1.54-4			BAR108
752-	+AR108	.92	0.0	-.92	0.0					
753-	PBAR	115	3	.0785	5.74-3	3.73-3	6.54-5			BAR115
754-	+AR115	-.435	-.635	.235	.535					AR115A
755-	+R115A	.17	1.0							
756-	PBAR	121	14	.035	.00278	.0381	7.1-5			PBAR121
757-	+BAR121	-.146	.371	-.146	-.529	.42	-.195			
758-	PBAR	122	14	.085	.00278	.0381	7.1-5			PBAR122
759-	+BAR122	-.146	-.371	-.146	.529	.42	.195			
760-	PBAR	126	14	.2058	1.6-4	.0849	5.4-4	1		PBAR126
761-	+BAR126	0.0	0.0	0.0	-1.176	0.0	1.144			
762-	PBAR	139	3	.39	.125	.195	.0013			PBAR139
763-	+BAR139	-.44	-1.56	-.44	.64	1.36	.64			BAR139
764-	+AR139	1.0	1.0							
765-	PBAR	140	3	.211	.061	.011				PBAR140
766-	+BAR140	.63	-.24	.63	.51	-.8	-.24	-.8	.51	BAR140
767-	+AR140	1.0	1.0							
768-	PBAR	146	3	.234	.065	.0033	6.9-4			PBAR146
769-	+BAR146	0.0	-.45	1.01	0.0	-1.01	0.0			BAR146
770-	+AR146	1.0	1.0							
771-	PBAR	147	3	.27	.14	.022	3.4-4			PBAR147
772-	+BAR147	.75	-1.66	-1.13	-.65	.75	.84	-1.13	.09	BAR147
773-	+AR147	1.0	1.0							
774-	PBAR	148	3	.354	.312	.029	4.2-4			PBAR148
775-	+BAR148	.95	-.63	-1.57	-.63	.90	.87	-1.57	.09	BAR148
776-	+AR148	1.0	1.0							
777-	PBAR	152	5	.114	.0043	.0168	.95-4			PBAR152
778-	+BAR152	.25	.69	.25	-.69	-.25	0.0			BAR152
779-	+AR152	1.0	1.0							
780-	PBAR	201	12	.1308	1.3131	1.	.6976-4	0.0		PBAR201
781-	+BAR201	.68	0.	-.68	0.	.67	0.	-.67	0.	PBAR201A
782-	+BAR201A	.4128	1.	0.						
783-	PBAR	202	12	.1304	1.1571	1.	.6955-4	0.0		PBAR202
784-	+BAR202	.67	0.	-.67	0.	.67	0.	-.67	0.	PBAR202A
785-	+BAR202A	.4110	1.	0.						
786-	PBAR	204	12	.1324	.9839	1.	.7061-4	0.0		PBAR204
787-	+BAR204	.70	0.	-.70	0.	.69	0.	-.69	0.	PBAR204A
788-	+BAR204A	.4199	1.	0.						
789-	PBAR	205	12	.1316	1.0587	1.	.7019-4	0.0		PBAR205
790-	+BAR205	.69	0.	-.69	0.	.68	0.	-.68	0.	PBAR205A
791-	+BAR205A	.4164	1.	0.						
792-	PBAR	211	12	.2910	1.2357	1.	.7012-3	0.0		PBAR211
793-	+BAR211	.67	0.	-.67	0.	.67	0.	-.67	0.	PBAR211A
794-	+BAR211A	.2302	1.	0.						
795-	PBAR	212	12	.29025	.29059	1.	.6987-3	0.0		PBAR212
796-	+BAR212	.67	0.	-.67	0.	.655	0.	-.655	0.	PBAR212A
797-	+BAR212A	.22825	1.	0.						
798-	PBAR	213	12	.28955	.29607	1.	.6962-3	0.0		PBAR213
799-	+BAR213	.655	0.	-.655	0.	.655	0.	-.655	0.	PBAR213A
800-	+BAR213A	.22625	1.	0.						

S O R T E D B U L K D A T A E C H O										
CARD COUNT	1	2	3	4	5	6	7	8	9	10
801-	PBAR	214	12	.22145	.26377	1.	.3184-3	0.0		PBAR214
802-	+BAR214	.655	8.	-.655	0.	.68	0.	-.68	3.	PBAR214A
803-	+BAR214A	.2412	1.	0.						
804-	PBAR	215	12	.22245	.25345	1.	.3205-3	0.0		PBAR215
805-	+BAR215	.68	0.	-.68	0.	.68	0.	-.68	0.	PBAR215A
806-	+BAR215A	.2446	1.	0.						
807-	PELAS	2001	7.68+4		18.2					
808-	PELAS	2002	2.76+6		18.2					
809-	PELAS	2003	1.35+4		550.					
810-	PELAS	2004	2.04+4		277.					
811-	PQUA01	200	40	.177	40	.122	200	1.60		PQU200
812-	+QU200	.81	-.81							
813-	PQUA01	201	40	.206	40	.141	200	1.60		PQU201
814-	+QU201	.81	-.81							
815-	PQUA01	202	40	.175	40	.120	200	1.60		PQU202
816-	+QU202	.81	-.81							
817-	PQUA01	203	40	.204	40	.140	200	1.62		PQU203
818-	+QU203	.81	-.81							
819-	PQUA01	204	40	.197	40	.135	200	1.62		PQU204
820-	+QU204	.81	-.81							
821-	PQUA01	205	40	.250	40	.171	200	1.60		PQU205
822-	+QU205	.81	-.81							
823-	PQUA01	206	40	.197	40	.135	200	1.62		PQU206
824-	+QU206	.81	-.81							
825-	PQUA01	207	40	.212	40	.145	200	1.62		PQU207
826-	+QU207	.81	-.81							
827-	PQUA01	208	10	.206	10	.141	200	1.60		PQU208
828-	+QU208	.81	-.81							
829-	PQUA01	209	10	.212	10	.145	200	3.31		PQU209
830-	+QU209	.81	-.81							
831-	PROD	119	117	.125	.042	.5				
832-	PSHEAR	118	117	.125						
833-	PTRIA1	3	13	.042	7	7.3-4	4	.25	1.16-6	14
834-	+4	.194	-.157							
835-	PTRIA1	47	8	.064	8	12.5-4	4	.25	1.16-6	1333
836-	+333	.141	-.141							
837-	PTRIA2	1	1	0.1		11	1	.08		
838-	PTRIA2	4	14	.09	.0					
839-	PTRIA2	5	14	.098	.0					
840-	PTRIA2	6	3	.050	.0	7	16	.008	.0	
841-	PTRIA2	8	14	.050	0.0					
842-	PTRIA2	14	16	.072						
843-	PTRIA2	21	1	0.12		2	2	.11		
844-	PTRIA2	22	2	0.16						
845-	PTRIA2	67	8	.128						
846-	PTRIA2	185	3	.38		186	3	.25		
847-	PTRIA2	187	3	.053		193	3	.125		
848-	PTRIA2	220	3	.04						
849-	SPC1	1	123456	22						
850-	SPC1	2	246	1	8	14	16	39	42	198

CARD COUNT	S O R T E D B U L K D A T A E C H O									
	1	2	3	4	5	6	7	8	9	10
851-	+98	151	159	160	169	170	31	61	91	199
852-	+99	121	100	130	70	141	179	80	81	
853-	SPC1	3	156	52	134	30	80	90	120	1533
854-	+533	150	135							
855-	SPC1	77	246	23						
856-	SPCA00	5	1	2	3	77				
	ENODATA									

THIS PAGE LEFT INTENTIONALLY BLANK

APPENDIX B

NASTRAN ELEMENT STRESSES

CALC ONLY

ELEMENT ID.		STRESS IN ROD ELEMENTS (C R O D)		AXIAL STRESS		TORSIONAL STRESS		SAFETY MARGIN	
890	1.7E+01	-9.613543E+00	2.1E+03	92C	1.571204E+03	1.9E+01	1.002467E+01	1.9E+01	2.0E+03

ELEMENT ID.		STRESS IN SHEAR PANELS (C S H E A R)		MAX SHEAR		AVG SHEAR		SAFETY MARGIN	
143	1.329212E+03	1.329212E+03	1.4E+01	144	2.503327E+03	2.503327E+03	2.503327E+03	1.4E+01	7.0E+00
145	2.733977E+03	2.733977E+03	6.3E+00	146	1.436218E+03	1.436218E+03	1.436218E+03	6.3E+00	1.3E+01

ELEMENT ID.		STRESS IN SCALAR SPRINGS (C E L A S I)		STRESS		ELEMENT ID.		STRESS	
2018	-1.584651E+03	2019	-1.917241E+03	2020	-3.577154E+03	2021	1.009444E+05	2025	-4.664450E+03
2022	6.657481E+03	2023	-4.597779E+03	2024	-2.350494E+03	2025	-4.664450E+03	2029	1.435858E+04
2026	2.736505E+03	2027	-7.307515E+03	2028	8.666799E+03	2029	1.435858E+04		

CALC ONLY

ELEMENT ID.	FIBRE DISTANCE	STRESSES IN GENERAL TRIANGULAR ELEMENTS (CTRIA1)		ANGLE	PRINCIPAL STRESSES (ZERO SHEAR)		MAX SHEAR
		NORMAL-X	NORMAL-Y		MAJOR	MINOR	
15	1.410000E-01	-6.064999E+02	-1.424596E+02	53.6630	6.404043E+02	-1.589364E+03	1.114884E+03
	-1.410000E-01	-2.303835E+03	-8.394782E+01	63.3217	6.658341E+02	-3.053617E+03	1.859725E+03
16	1.410000E-01	-7.568542E+02	-6.656857E+02	46.4618	1.824540E+02	-1.604994E+03	8.937240E+02
	-1.410000E-01	1.106651E+02	-8.529551E+01	43.4008	1.768771E+03	-1.743402E+03	1.756087E+03
17	1.410000E-01	-1.077333E+02	-1.383210E+02	44.7521	1.644046E+03	-1.890101E+03	1.767074E+03
	-1.410000E-01	-3.978972E+02	-2.494190E+02	45.8624	2.142928E+03	-2.796244E+03	2.466596E+03
18	1.410000E-01	-3.970285E+03	1.325710E+03	73.3418	1.846502E+03	-4.491077E+03	3.168789E+03
	-1.410000E-01	-9.743133E+03	-2.687210E+03	85.1838	-2.636761E+03	-9.793583E+03	3.578411E+03
19	1.410000E-01	-3.771307E+03	1.157890E+03	59.1232	3.900941E+03	-6.514358E+03	5.207649E+03
	-1.410000E-01	-9.545101E+03	-1.493409E+03	73.5672	-7.262729E+02	-1.031224E+04	4.792982E+03
20	1.410000E-01	-2.653205E+04	1.735346E+03	80.4406	2.550474E+03	-2.735798E+04	1.495922E+04
	-1.410000E-01	-3.123517E+04	2.108258E+03	84.9304	2.372754E+03	-3.149966E+04	1.693621E+04
21	1.410000E-01	-2.045939E+04	-1.387542E+03	-82.2604	-8.780848E+02	-2.896885E+04	1.404538E+04
	-1.410000E-01	-2.989654E+04	3.711796E+03	-81.5995	4.461076E+03	-3.064582E+04	1.755345E+04
22	1.410000E-01	-1.543438E+04	-3.432655E+03	-74.1219	-2.024003E+03	-2.084303E+04	9.409516E+03
	-1.410000E-01	-1.981803E+04	3.568823E+03	-80.2504	4.288296E+03	-2.052950E+04	1.240430E+04
23	1.410000E-01	-1.775130E+04	1.842025E+03	-83.7762	2.077971E+03	-1.799725E+04	1.803761E+04
	-1.410000E-01	-1.943761E+04	3.689948E+03	-88.4077	3.618764E+03	-1.945543E+04	1.153709E+04
44	1.410000E-01	-1.103981E+03	-1.416642E+03	41.5861	5.467030E+01	-2.575294E+03	1.314932E+03
	-1.410000E-01	-1.022773E+03	5.32597E+02	57.0889	1.653633E+03	-2.143847E+03	1.898740E+03
45	1.410000E-01	-1.461148E+03	-1.711337E+03	41.5099	-5.568758E+02	-2.615609E+03	1.029367E+03
	-1.410000E-01	-3.605262E+02	-1.091525E+03	37.3730	6.631785E+02	-2.115230E+03	1.389204E+03
46	1.410000E-01	7.630434E+02	1.703342E+03	50.1188	3.878503E+03	-1.442117E+03	2.645310E+03
	-1.410000E-01	-1.578284E+03	-1.995309E+03	43.0032	6.060506E+02	-4.089644E+03	2.347847E+03
47	1.410000E-01	-9.424787E+03	1.370935E+03	82.9828	1.537018E+03	-9.598870E+03	5.563944E+03
	-1.410000E-01	-1.214641E+04	-3.026209E+03	84.7994	-2.990025E+03	-1.222259E+04	4.536284E+03
48	1.040000E-01	-7.194676E+03	3.811940E+02	78.6914	6.136531E+02	-7.512136E+03	4.062894E+03
	-1.670000E-01	-9.441131E+03	-2.780680E+03	76.7754	-2.391351E+03	-9.830460E+03	3.719554E+03
49	1.040000E-01	-2.073344E+04	-8.693650E+02	85.2690	-7.845323E+02	-2.081827E+04	1.801587E+04
	-1.670000E-01	-1.739766E+04	2.794938E+03	84.4826	2.890766E+03	-1.759349E+04	1.029213E+04
50	1.040000E-01	-2.212970E+04	-3.701928E+03	-80.9991	-3.227665E+03	-2.280396E+04	9.588149E+03
	-1.670000E-01	-1.564284E+04	6.286468E+03	-84.0712	6.444668E+03	-1.588134E+04	1.116285E+04

CALC ONLY

ELEMENT ID.	FIBRE DISTANCE	STRESSES IN GENERATOR		STRESSES IN ELEMENT COORD SYSTEM		PRINCIPAL STRESSES (ZERO SHEAR)		MAX SHEAR
		NORMAL-Y	SHEAR-XY	ANGLE	MAJOR	MINOR		
51	1.040000E-01	-2.006281E+04	-4.204941E+03	-80.5755	-3.755082E+03	-2.053267E+04	8.388796E+03	
	-1.670000E-01	-1.306028E+04	6.083749E+03	-82.2772	6.442407E+03	-1.341894E+04	9.930673E+03	
52	1.410000E-01	-2.361348E+04	1.405495E+03	-81.4021	1.992464E+03	-2.427045E+04	1.313145E+04	
	-1.410000E-01	-2.137060E+04	3.818566E+03	-80.2760	4.580646E+03	-2.213268E+04	1.335666E+04	
53	1.410000E-01	7.615341E+03	2.791366E+03	-31.2229	1.041749E+04	-1.078164E+01	5.214135E+03	
	-1.410000E-01	3.688254E+03	-1.571503E+03	-29.8503	6.271009E+03	-4.154258E+03	5.212634E+03	
56	1.410000E-01	-1.881147E+03	-2.932650E+03	-24.7073	-1.590718E+03	-3.215279E+03	0.082803E+02	
	-1.410000E-01	-7.696689E+01	1.177317E+02	-50.4340	5.364823E+02	-4.956175E+02	5.160499E+02	
57	1.410000E-01	-1.654438E+03	-5.673898E+02	-88.9358	-5.670146E+02	-1.654813E+03	5.438893E+02	
	-1.410000E-01	-1.263006E+03	-3.166838E+02	-66.1584	-0.216947E+01	-1.517520E+03	7.176753E+02	
58	1.410000E-01	2.303246E+02	2.768950E+03	63.6217	3.596972E+03	-5.976971E+02	2.007334E+03	
	-1.410000E-01	-2.805370E+03	1.181084E+03	46.0774	-1.579010E+03	-3.962849E+03	1.181820E+03	
59	1.410000E-01	-9.649318E+03	1.028026E+03	89.4742	1.028026E+03	-9.650217E+03	5.339571E+03	
	-1.410000E-01	-1.095210E+04	-2.129207E+03	88.1996	-2.120560E+03	-1.095082E+04	4.420132E+03	
70	1.040000E-01	-0.380990E+03	2.583245E+02	-88.9587	2.611795E+02	-0.380845E+03	4.322512E+03	
	-1.670000E-01	-4.770507E+03	2.874252E+03	86.6952	2.087131E+03	-4.793366E+03	3.645308E+03	
71	1.040000E-01	-1.011111E+04	-1.239003E+03	-03.5370	-1.123752E+03	-1.022645E+04	4.551347E+03	
	-1.670000E-01	-8.921621E+03	1.094408E+03	-07.7910	1.910606E+03	-8.937739E+03	3.829172E+03	
72	1.040000E-01	-1.106912E+04	-1.401450E+03	-74.5270	-5.991592E+02	-1.107141E+04	5.636127E+03	
	-1.670000E-01	-5.215860E+03	7.212534E+03	-70.5169	7.747510E+03	-5.750836E+03	6.749173E+03	
73	1.040000E-01	-8.353692E+03	-1.294004E+03	-77.3403	-9.108868E+02	-8.728827E+03	3.309979E+03	
	-1.670000E-01	-7.196495E+03	2.365104E+03	-79.1968	2.726478E+03	-7.557609E+03	5.142144E+03	
74	1.410000E-01	-1.139108E+04	-6.342106E+02	-72.8730	4.944311E+02	-1.251973E+04	6.307079E+03	
	-1.410000E-01	-1.034129E+04	5.157910E+02	-71.7552	1.039459E+03	-1.166496E+04	6.752209E+03	
75	1.410000E-01	-1.640144E+03	-0.770486E+01	-54.0506	1.634405E+03	-3.362254E+03	2.498330E+03	
	-1.410000E-01	-9.408622E+01	4.168467E+02	-47.6754	2.980918E+03	-2.578157E+03	2.739537E+03	
86	1.410000E-01	-2.050099E+03	-1.4417928E+03	-52.6806	-1.187842E+03	-2.290185E+03	5.461717E+02	
	-1.410000E-01	-2.492661E+03	3.895379E+02	-76.5409	5.646486E+02	-2.667772E+03	1.616210E+03	
87	1.410000E-01	-2.008545E+03	-1.672729E+02	-84.0952	-1.473643E+02	-2.028454E+03	9.405448E+02	
	-1.410000E-01	-2.306773E+03	-1.069769E+02	-72.0555	3.618348E+01	-2.531933E+03	1.284058E+03	
88	1.410000E-01	-1.008875E+03	2.200401E+03	75.9180	2.415906E+03	-1.224380E+03	1.620143E+03	
	-1.410000E-01	-3.021030E+03	-1.811900E+03	67.1282	-1.155009E+03	-3.282921E+03	8.664565E+02	

NADC-77149-30

CALC ONLY

ELEMENT ID.	FIBRE DISTANCE	STRESSES		T N G E N E R A L T R I A N G U L A R E L E M E N T S		P R I N C I P A L S T R E S S E S (Z E R O S H E A R)		MAX SHEAR
		NORMAL-X	NORMAL-Y	SHEAR-XY	ANGLE	MAJOR	MINOR	
89	1.41000E-01	-8.39793E+03	4.27609E+02	-4.32080E+02	-87.2038	4.48713E+02	-8.41903E+03	4.433875E+03
	-1.41000E-01	-8.163657E+03	-8.58333E+02	2.04508E+02	88.3977	-8.52612E+02	-8.16937E+03	3.658383E+03
90	1.04800E-01	-6.76517E+03	-4.20842E+02	-1.08704E+03	-80.5422	-2.39755E+02	-6.94626E+03	3.353255E+03
	-1.67000E-01	-4.33833E+03	1.79145E+03	-3.34673E+02	-86.9841	1.809677E+03	-4.35654E+03	3.083113E+03
91	1.04000E-01	-6.53089E+03	-6.27764E+02	-1.18840E+03	-79.0343	-3.97500E+02	-6.76115E+03	3.181827E+03
	-1.67000E-01	-6.03701E+03	5.55393E+02	-7.85831E+02	-83.2954	6.47772E+02	-6.12939E+03	3.388582E+03
92	1.04000E-01	-7.27301E+03	-1.51197E+03	-2.22666E+03	-71.1478	-7.51691E+02	-6.03329E+03	3.640904E+03
	-1.67000E-01	-4.27879E+03	3.29713E+03	-2.19976E+03	-74.9276	3.88953E+03	-4.87120E+03	4.380370E+03
93	1.04800E-01	-5.33057E+03	-1.89879E+03	-1.33969E+03	-73.8298	-7.10334E+02	-5.71903E+03	2.504351E+03
	-1.67000E-01	-5.15570E+03	1.10840E+03	-1.68275E+03	-75.8761	1.53183E+03	-5.57912E+03	3.555479E+03
94	1.41000E-01	-7.05999E+03	-7.95675E+02	-2.97182E+03	-58.2524	3.89818E+02	-8.24549E+03	4.317656E+03
	-1.41000E-01	-7.23874E+03	-1.40112E+03	-3.37365E+03	-68.6043	1.31171E+03	-8.62056E+03	4.966142E+03
95	1.41000E-01	-4.22524E+03	-2.81150E+02	-2.48171E+03	-64.2359	9.16637E+02	-5.42303E+03	3.169838E+03
	-1.41000E-01	-4.50131E+03	-3.24980E+02	-3.12503E+03	-61.8755	1.34534E+03	-6.17164E+03	3.758497E+03
106	1.41000E-01	-1.74328E+03	-5.07711E+02	1.81495E+02	81.6217	-4.80980E+02	-1.74001E+03	6.295175E+02
	-1.41000E-01	-2.02327E+03	2.09571E+02	-9.26340E+01	-87.6243	2.09514E+02	-2.02711E+03	1.118316E+03
107	1.41000E-01	-2.24700E+02	-8.44770E+02	1.93865E+01	1.7721	-2.21100E+02	-8.48306E+02	3.136029E+02
	-1.41000E-01	-2.10359E+02	-6.62681E+02	2.76285E+02	25.3485	-7.94735E+01	-7.93567E+02	3.570471E+02
108	1.41000E-01	1.06348E+03	-3.27237E+03	-2.61033E+02	-3.6880	1.08760E+03	-3.29048E+03	2.189045E+03
	-1.41000E-01	-6.56185E+02	-3.90060E+03	-4.58655E+02	-7.6937	-5.92592E+02	-3.96419E+03	1.685803E+03
109	1.41000E-01	-4.35307E+02	-5.61186E+03	2.60341E+02	2.8719	-4.22247E+02	-5.62492E+03	2.601336E+03
	-1.41000E-01	-4.45693E+02	-4.83028E+03	-2.62017E+02	-3.4078	-4.30091E+02	-4.84588E+03	2.207897E+03
110	1.41000E-01	-3.90367E+02	-6.14407E+03	9.67907E+02	9.2977	-2.31906E+02	-6.30253E+03	3.035313E+03
	-1.41000E-01	7.22795E+02	-4.98394E+03	1.41311E+02	1.4176	7.26292E+02	-4.98744E+03	2.856869E+03
111	1.41000E-01	-1.57040E+01	-2.17259E+03	2.58196E+02	6.7320	1.47734E+01	-2.20307E+03	1.108923E+03
	-1.41000E-01	-1.97182E+02	-3.96127E+03	5.78779E+01	.8807	-1.96292E+02	-3.96216E+03	1.882937E+03
112	1.41000E-01	-1.44827E+03	-4.34062E+03	1.38764E+03	21.9084	-8.90208E+02	-4.89869E+03	2.004243E+03
	-1.41000E-01	1.71343E+03	-2.34667E+03	1.32879E+03	16.6836	2.10965E+03	-2.74290E+03	2.426270E+03
113	1.41000E-01	-1.57756E+02	-3.13802E+03	1.40536E+03	21.6615	4.80413E+02	-3.69619E+03	2.048304E+03
	-1.41000E-01	-2.82888E+02	-5.26514E+03	1.72086E+03	17.3183	2.53704E+02	-5.80173E+03	3.027721E+03
114	1.41000E-01	-1.80482E+02	-2.35413E+03	2.25632E+03	32.1404	1.23712E+03	-3.77174E+03	2.504431E+03
	-1.41000E-01	-1.11392E+02	-2.87676E+03	2.79391E+03	31.8348	1.62326E+03	-4.61142E+03	3.117340E+03

CALC ONLY

ELEMENT ID.	STRESSES IN GENERAL TRIANGULAR ELEMENTS (CENTRIAL)		PRINCIPAL STRESSES (ZERO SHEAR)		MAX SHEAR			
	FIBRE DISTANCE	STRESSES IN ELEMENT COORD SYSTEM	ANGLE	MAJOR MINOR				
115	1.410000E-01	-9.062974E+03	-7.960617E+02	-3.559209E+03	-69.6346	5.251522E+02	-1.038419E+04	5.454670E+03
	-1.410000E-01	-8.148715E+03	-6.622230E+02	-3.712916E+03	-67.6165	8.668516E+02	-9.677619E+03	5.272336E+03
152	1.410000E-01	2.370120E+03	-7.645328E+03	4.771640E+02	2.7215	2.392802E+03	-7.668011E+03	5.030+06E+03
	-1.410000E-01	1.383093E+03	-3.575343E+03	-2.773800E+02	-3.1919	1.398561E+03	-3.590811E+03	2.494686E+03
170	1.410000E-01	-1.548033E+03	-1.213477E+04	-6.587375E+03	-25.6080	1.609234E+03	-1.529204E+04	8.450530E+03
	-1.410000E-01	-2.185072E+03	-1.991864E+04	-4.817731E+03	-14.2046	-8.855866E+02	-2.113813E+04	1.012527E+04
171	1.410000E-01	8.061981E+02	-1.675195E+04	-2.584401E+03	-8.2017	1.178696E+03	-1.712444E+04	9.151570E+03
	-1.410000E-01	6.756670E+02	-1.655804E+04	-1.125223E+03	-3.7199	7.488245E+02	-1.663120E+04	8.690013E+03
172	1.410000E-01	-1.642660E+03	-1.614736E+04	6.922146E+03	19.9951	8.761268E+02	-2.066614E+04	1.077114E+04
	-1.410000E-01	-2.776614E+03	-3.158949E+04	7.438730E+03	13.6547	-9.694726E+02	-3.339663E+04	1.5213358E+04
173	1.410000E-01	-4.492615E+03	-3.005719E+04	1.734172E+03	3.8631	-4.375513E+03	-3.017429E+04	1.289939E+04
	-1.410000E-01	8.779574E+03	-1.834902E+04	1.830725E+03	3.8433	8.902559E+03	-1.847200E+04	1.368728E+04
179	1.040000E-01	1.114549E+02	-1.594585E+04	-3.226687E+03	-10.9475	7.355921E+02	-1.656999E+04	8.652789E+03
	-1.670000E-01	6.860878E+02	-1.093730E+04	-2.098919E+03	-9.9921	9.758849E+02	-1.130710E+04	6.141492E+03
180	1.040000E-01	-7.602213E+02	-1.377065E+04	6.740776E+01	.2968	-7.598721E+02	-1.377100E+04	6.505366E+03
	-1.670000E-01	1.493468E+03	-1.433905E+04	-1.104234E+03	-3.9705	1.570112E+03	-1.441568E+04	7.992303E+03
181	1.040000E-01	-3.189822E+03	-2.362107E+04	3.593903E+03	9.6911	-2.576082E+03	-2.423481E+04	1.082336E+04
	-1.670000E-01	9.486039E+03	-9.166315E+03	3.437698E+03	10.1171	1.009945E+04	-9.779723E+03	9.939595E+03
182	1.040000E-01	-2.150524E+03	-1.790539E+04	2.102492E+03	7.4720	-1.874772E+03	-1.818114E+04	8.153183E+03
	-1.670000E-01	5.424080E+03	-1.883347E+04	1.521655E+03	3.5754	5.519160E+03	-1.892855E+04	1.222388E+04
183	1.410000E-01	2.567935E+03	-6.544110E+03	6.102838E+03	26.6286	5.627815E+03	-9.603990E+03	7.615903E+03
	-1.410000E-01	9.957950E+02	-6.784293E+03	5.171333E+03	26.5242	3.576851E+03	-9.365349E+03	6.471100E+03
184	1.410000E-01	1.060504E+02	-6.646116E+03	2.637068E+03	18.9951	1.014614E+03	-7.553679E+03	4.284246E+03
	-1.410000E-01	6.229751E+02	-5.650631E+03	3.612387E+03	24.5154	2.270404E+03	-7.298060E+03	4.784232E+03

NADC-77149-30

CALC ONLY

ELEMENT ID.	FIBRE DISTANCE	STRESSES IN GENERAL COORD SYSTEM		PRINCIPAL STRESSES (ZERO SHEAR)		MAX SHEAR		
		NORMAL-X	NORMAL-Y	MAJOR	MINOR			
1	-5.00000E-02 5.00000E-02	-1.360224E+03 -1.620354E+03	-1.022184E+02 4.818369E+02	-9.729043E+02 -1.236959E+03	-61.4417 -65.1780	4.273075E+02 1.053969E+03	-1.869747E+03 -2.192486E+03	1.158527E+03 1.623228E+03
2	-5.00000E-02 5.00000E-02	-1.239876E+02 5.262525E+02	-1.173665E+03 -8.585501E+02	1.104067E+03 1.142750E+03	32.3405 29.3940	5.700671E+02 1.170001E+03	-1.872719E+03 -1.502299E+03	1.221393E+03 1.336150E+03
3	-5.00000E-02 5.00000E-02	-5.795767E+02 -1.207929E+02	-5.533576E+01 1.426812E+03	-1.069079E+03 -6.840632E+02	-51.8881 -69.2612	7.832873E+02 1.685828E+03	-1.418200E+03 -3.798083E+02	1.100744E+03 1.032819E+03
4	-5.00000E-02 5.00000E-02	1.399059E+03 -7.972042E+02	0.389907E+02 1.330098E+03	-1.545174E+03 -5.333001E+02	-39.8639 -76.6857	2.689369E+03 1.456306E+03	-4.513196E+02 -9.234113E+02	1.570344E+03 1.189858E+03
5	-5.00000E-02 5.00000E-02	-1.673355E+03 -1.171255E+03	-3.956913E+02 1.187326E+03	-1.830641E+03 -1.151759E+03	-54.6186 -67.8383	9.043822E+02 1.656451E+03	-2.973428E+03 -1.648381E+03	1.938905E+03 1.648416E+03
6	-5.00000E-02 5.00000E-02	1.026727E+02 1.39204E+02	1.841638E+03 -3.078771E+01	-9.639568E+02 -9.842404E+02	-66.0251 -42.4641	2.270313E+03 1.044676E+03	-3.260021E+02 -9.315429E+02	1.298157E+03 9.881093E+02
7	-5.00000E-02 5.00000E-02	-5.888466E+02 -5.450276E+02	-1.433163E+02 2.011430E+02	-1.753584E+03 -1.035091E+03	-48.6199 -54.9105	1.401595E+03 9.283336E+02	-2.133758E+03 -1.272210E+03	1.767676E+03 1.100276E+03
8	-5.00000E-02 5.00000E-02	-1.365999E+03 1.681914E+03	-2.764029E+02 4.559150E+02	-1.562895E+03 -1.044037E+03	-54.7719 -29.7905	6.272444E+02 2.279610E+03	-2.489646E+03 -1.417801E+02	1.658445E+03 1.210695E+03
9	-5.00000E-02 5.00000E-02	1.732659E+03 -5.617595E+02	5.143949E+03 -3.416321E+03	-9.193558E+02 -1.382163E+03	-75.8375 -22.0400	5.375941E+03 -2.207581E+00	1.500666E+03 -3.975873E+03	1.937638E+03 1.986833E+03
10	-5.00000E-02 5.00000E-02	-2.678671E+03 3.218392E+03	-7.258763E+02 1.644196E+03	-2.479169E+03 -2.027912E+02	-55.7483 -7.2208	9.622398E+02 3.244074E+03	-4.366787E+03 1.618514E+03	2.664513E+03 8.127803E+02
11	-5.00000E-02 5.00000E-02	1.169613E+03 -1.810015E+03	2.943784E+03 -3.820800E+03	-3.992042E+02 -1.352224E+03	-77.8836 -26.6844	3.029503E+03 -1.130378E+03	1.083894E+03 -4.500438E+03	9.729046E+02 1.685030E+03
12	-5.00000E-02 5.00000E-02	-5.192969E+02 2.952444E+02	4.748321E+02 -2.974331E+03	-5.890431E+02 -1.232967E+03	-65.0797 -18.5119	7.485107E+02 7.080740E+02	-7.929755E+02 -3.387161E+03	7.707431E+02 2.047618E+03
13	-5.00000E-02 5.00000E-02	1.666855E+03 -2.416256E+03	4.418247E+03 -3.902712E+03	-2.210762E+02 1.336902E+03	-85.4353 30.4644	4.435897E+03 -1.629877E+03	1.649204E+03 -4.688090E+03	1.393347E+03 1.529606E+03
14	-5.00000E-02 5.00000E-02	4.749098E+03 -3.662264E+03	1.336906E+03 -2.340845E+03	-1.613824E+03 6.990967E+02	-21.7040 66.6915	5.391446E+03 -2.039643E+03	6.945567E+02 -3.963465E+03	2.348445E+03 9.619112E+02
24	-6.40000E-02 6.40000E-02	2.983215E+02 1.082719E+03	-7.970310E+02 1.046527E+03	3.062351E+02 -1.085637E+03	14.6067 -44.5225	3.781335E+02 2.150411E+03	-0.768430E+02 -2.116510E+01	6.274883E+02 1.085788E+03
25	-6.40000E-02 6.40000E-02	-4.155854E+02 -2.641147E+02	-6.667996E+03 -6.122991E+03	-2.727564E+03 -2.576484E+03	-20.5521 -20.6661	6.070364E+02 7.077132E+02	-7.690617E+03 -7.094819E+03	4.148627E+03 3.901266E+03

NADC-77149-30

CALC ONLY

ELEMENT ID.	FIBRE DISTANCE	STRESSES IN ELEMENT COORD SYSTEM		TRIAxIAL ELEMENTS (C T R I A 2)		PRINCIPAL STRESSES (ZERO SHEAR)		MAX SHEAR
		NORMAL-X	NORMAL-Y	SHEAR-XY	ANGLE	MAJOR	MINOR	
26	-6.40000E-02	5.363504E+03	2.298703E+02	2.573909E+02	2.8631	5.376453E+03	2.169977E+02	2.579728E+03
	6.40000E-02	5.207374E+03	5.602471E+02	2.995419E+02	3.6729	5.226602E+03	5.410190E+02	2.342791E+03
27	-6.40000E-02	1.187728E+04	3.338943E+02	1.214011E+03	5.9392	1.200357E+04	2.075992E+02	5.897987E+03
	6.40000E-02	1.119933E+04	-1.134070E+03	1.291569E+03	5.9146	1.133313E+04	-1.267873E+03	6.300502E+03
28	-6.40000E-02	1.241385E+04	1.726951E+03	5.074413E+02	2.7149	1.242792E+04	1.702888E+03	5.362514E+03
	6.40000E-02	1.062946E+04	-2.639014E+03	4.440765E+02	1.9148	1.064430E+04	-2.653860E+03	6.845082E+03
29	-6.40000E-02	1.263462E+04	1.543803E+03	5.957305E+02	3.0658	1.266653E+04	1.511896E+03	5.577316E+03
	6.40000E-02	1.119847E+04	-2.528500E+03	5.966962E+02	2.4843	1.122436E+04	-2.554309E+03	6.883776E+03
30	-3.60000E-02	-2.255643E+03	-1.880044E+03	-3.499431E+03	-46.5359	1.436624E+03	-5.572310E+03	3.504467E+03
	3.60000E-02	-1.982241E+03	-1.367611E+03	-3.652203E+03	-67.4049	1.998184E+03	-5.349035E+03	3.685109E+03
31	-3.60000E-02	-1.896357E+03	-9.806253E+02	-3.013002E+03	-49.2832	1.604503E+03	-4.409405E+03	3.016994E+03
	3.60000E-02	-1.754446E+03	-6.720556E+02	-3.047384E+03	-50.0352	1.881816E+03	-4.300318E+03	3.0995067E+03
32	-3.60000E-02	-1.565717E+03	-9.054271E+02	-4.091075E+03	-46.6096	2.962770E+03	-5.233915E+03	4.098343E+03
	3.60000E-02	-1.013033E+03	9.897779E+00	-3.982158E+03	-48.6627	3.512940E+03	-4.516875E+03	4.914907E+03
33	-3.60000E-02	-8.591959E+02	5.737482E+02	-3.266092E+03	-51.1077	7.200912E+02	-3.496660E+03	3.343706E+03
	3.60000E-02	-9.407340E+02	4.735496E+02	-3.543543E+03	-50.6420	3.379820E+02	-3.884708E+03	3.613412E+03
34	-3.60000E-02	-1.419757E+02	7.811990E+02	-4.681107E+03	-47.8150	5.023422E+03	-4.384190E+03	4.703014E+03
	3.60000E-02	-1.778954E+02	7.404226E+02	-4.697994E+03	-47.6811	4.901905E+03	-4.455536E+03	4.718849E+03
35	-3.60000E-02	1.883265E+03	9.850656E+02	-5.140942E+03	-44.0540	6.110069E+03	-4.163940E+03	5.161009E+03
	3.60000E-02	1.000474E+03	1.196804E+03	-4.241909E+03	-45.6604	5.343131E+03	-3.144758E+03	4.243037E+03
36	-3.60000E-02	6.609321E+02	2.098904E+03	-2.593400E+03	-29.1786	2.115060E+03	-2.977500E+03	3.045204E+03
	3.60000E-02	1.620752E+03	-1.323111E+03	-3.431402E+03	-29.4054	2.991124E+03	-2.993483E+03	3.042304E+03
37	-3.60000E-02	-2.327034E+03	-2.353365E+03	-1.366402E+03	-44.7240	-9.736535E+02	-3.706745E+03	1.366546E+03
	3.60000E-02	-1.637653E+03	-2.504704E+02	-1.288932E+03	-59.0735	5.137405E+02	-2.409872E+03	1.461806E+03
38	-3.60000E-02	2.694415E+02	-1.324186E+03	-1.058376E+03	-26.5126	7.974188E+02	-1.852163E+03	1.3249791E+03
	3.60000E-02	5.470710E+02	3.186963E+02	-8.781442E+02	-41.2956	1.318421E+03	-4.526536E+02	8.055371E+02
39	-3.60000E-02	-1.124704E+03	-2.568736E+02	-1.187395E+03	-55.0378	5.734063E+02	-1.954984E+03	1.264195E+03
	3.60000E-02	-3.882559E+02	2.174686E+03	-1.355745E+03	-66.6934	2.758748E+03	-9.723179E+02	1.865533E+03
40	-5.50000E-02	1.726844E+03	1.425442E+03	4.559015E+03	44.0534	6.137649E+03	-2.905362E+03	4.561505E+03
	5.50000E-02	1.702958E+03	1.159701E+03	4.611232E+03	43.3147	6.050593E+03	-3.187053E+03	4.619223E+03
41	-5.50000E-02	-1.467360E+03	2.702174E+01	-3.524626E+03	-50.9845	2.882786E+03	-4.323124E+03	3.602355E+03
	5.50000E-02	-1.557017E+03	3.146681E+01	-3.560573E+03	-51.2674	2.885306E+03	-4.410857E+03	3.648081E+03

NADC-77149-30

CALC ONLY

ELEMENT ID.	FIBRE DISTANCE	STRESSES IN ELEMENTAL COORD SYSTEM		SHEAR-XY	ANGLE		PRINCIPAL STRESSES (ZERO SHEAR)		MINOR	MAX SHEAR
		NORMAL-X	NORMAL-Y		MAJOR	MINOR				
42	-8.00000E-02 8.00000E-02	-1.206769E+03 -1.177620E+03	-7.041127E+02 -1.426253E+02	-2.096971E+03 -2.392825E+03	-48.4172 -51.1017	1.156538E+03 1.708022E+03	-3.067419E+03 -3.108267E+03	2.111979E+03 2.448145E+03		
43	-8.00000E-02 8.00000E-02	5.917503E+01 6.910140E+02	1.797866E+03 2.882845E+03	-1.692333E+03 -1.539246E+03	-58.5933 -62.7251	2.831263E+03 3.676456E+03	-9.742225E+02 -1.025367E+02	1.902743E+03 1.889526E+03		
54	-4.50000E-02 4.50000E-02	-3.723328E+03 -2.322678E+03	-2.159643E+04 -2.068208E+04	-1.074613E+02 5.421261E+02	-3.3445 1.6899	-3.722682E+03 -2.306684E+03	-2.159712E+04 -2.069808E+04	8.937222E+03 9.195637E+03		
55	-4.50000E-02 4.50000E-02	4.297809E+03 4.980191E+03	9.560344E+03 1.194404E+04	9.845566E+03 1.055931E+04	52.4821 54.1250	1.711922E+04 1.958070E+04	-3.261064E+03 -2.656468E+03	1.019014E+04 1.111058E+04		
56	-4.50000E-02 4.50000E-02	-9.369537E+02 1.599401E+03	3.631160E+03 4.709696E+03	-3.294290E+03 -2.280462E+03	-62.3675 -52.1459	5.355756E+03 5.914800E+03	-2.661530E+03 3.942982E+02	4.008643E+03 2.760252E+03		
57	-4.50000E-02 4.50000E-02	1.208610E+04 1.373652E+04	6.734238E+03 7.122581E+03	-3.331212E+03 -3.666142E+03	-25.6127 -23.9743	1.368306E+04 1.536682E+04	5.137281E+03 5.492200E+03	4.272890E+03 4.937270E+03		
58	-4.50000E-02 4.50000E-02	1.111702E+04 1.210008E+04	2.371205E+03 3.590275E+03	2.829378E+03 2.774331E+03	16.4518 16.5528	1.195260E+04 1.292465E+04	1.535692E+03 2.765702E+03	5.209453E+03 5.079476E+03		
59	-4.50000E-02 4.50000E-02	1.515514E+04 1.554093E+04	7.809186E+03 8.383664E+03	5.352548E+02 6.116622E+02	4.1456 4.8497	1.519394E+04 1.559282E+04	7.770322E+03 8.331767E+03	3.711774E+03 3.630520E+03		
60	-3.60000E-02 3.60000E-02	-2.617007E+02 3.123665E+02	4.107976E+02 2.196892E+03	-3.127086E+03 -3.106718E+03	-48.0587 -53.4362	3.219661E+03 4.501097E+03	-3.070564E+03 -1.991839E+03	3.145113E+03 3.246468E+03		
61	-3.60000E-02 3.60000E-02	2.410241E+03 2.296717E+03	3.278760E+03 3.122414E+03	9.742391E+02 1.209096E+03	57.0126 54.4263	3.911114E+03 3.987203E+03	1.777887E+03 1.431929E+03	1.066513E+03 1.277637E+03		
62	-3.60000E-02 3.60000E-02	2.685542E+02 -2.029221E+02	-1.642061E+03 -1.638824E+03	-1.813076E+03 -1.799500E+03	-31.1077 -34.1247	1.362602E+03 1.016562E+03	-2.736109E+03 -2.858308E+03	2.849335E+03 1.937435E+03		
63	-3.60000E-02 3.60000E-02	-4.955727E+02 -7.035285E+02	-1.362574E+03 -2.236673E+03	1.111021E+03 9.931101E+02	31.1459 26.1879	4.758536E+02 -2.155488E+02	-2.034000E+03 -2.724653E+03	1.254927E+03 1.254552E+03		
64	-3.60000E-02 3.60000E-02	-2.806334E+02 -4.942396E+02	-1.622186E+03 -1.600612E+03	-1.414995E+03 -1.487979E+03	-32.3113 -34.8832	6.137124E+02 5.400552E+02	-2.516531E+03 -2.634907E+03	1.565122E+03 1.587481E+03		
65	-3.60000E-02 3.60000E-02	1.476098E+02 4.309594E+02	-3.723357E+02 -1.067312E+03	7.511246E+01 1.178087E+02	8.0576 4.4686	1.582433E+02 4.401661E+02	-3.829691E+02 -1.076519E+03	2.705062E+02 7.583426E+02		
76	-4.50000E-02 4.50000E-02	-8.147165E+03 -8.772143E+03	-1.561724E+03 -1.756255E+03	-1.993615E+03 -2.030533E+03	-74.4034 -74.9580	-1.005222E+03 -1.210958E+03	-8.703666E+03 -9.317440E+03	3.849221E+03 4.053241E+03		
77	-4.50000E-02 4.50000E-02	6.336486E+03 6.188058E+03	4.444343E+03 4.030127E+03	-1.097960E+04 -1.162677E+04	-42.5376 -42.3491	1.641073E+04 1.678582E+04	-5.629869E+03 -6.567631E+03	1.102028E+04 1.167672E+04		

CALC ONLY

ELEMENT ID.	STRESSES IN ELEMENT COORD SYSTEM	T R I A N G U L A R E L E M E N T S (C T R I A Z)		ANGLE	P R I N C I P A L S T R E S S E S (Z E R O S H E A R)		MAX SHEAR
		NORMAL-X	NORMAL-Y		MAJOR	MINOR	
78	4.846555E+03 4.824736E+03	1.159600E+02 -2.877132E+02	-1.463267E+03 -1.515670E+03	-15.8713 -15.3325	5.262585E+03 5.240302E+03	-3.000700E+02 -7.032792E+02	2.791327E+03 2.971791E+03
79	1.158425E+04 9.623649E+03	5.216494E+03 -3.079049E+02	-7.680061E+03 -7.194463E+03	-33.7415 -27.6929	1.671426E+04 1.339968E+04	8.648307E+01 -4.008393E+03	6.313867E+03 8.741810E+03
80	9.586409E+03 1.067307E+04	3.769782E+02 1.657613E+03	-1.487311E+03 -5.936598E+02	-8.9502 -3.7580	9.820649E+03 1.071196E+04	1.427374E+02 1.618715E+03	4.839956E+03 4.546624E+03
81	1.443194E+04 1.745930E+04	1.521661E+03 7.302268E+03	-3.569356E+03 -4.664679E+03	-14.4708 -21.2839	1.535315E+04 1.927647E+04	6.004495E+02 5.485033E+03	7.376350E+03 6.895596E+03
82	-7.348701E+02 -5.597802E+02	-4.192119E+03 -2.896680E+03	6.178304E+02 6.717558E+02	9.8337 14.9000	-6.277775E+02 -3.720396E+02	-5.299211E+03 -3.075421E+03	1.835717E+03 1.351693E+03
83	-1.071219E+03 4.535397E+02	-4.285904E+03 -3.349403E+03	-2.252795E+02 -1.642611E+02	-3.9891 -2.4687	-1.055509E+03 4.606215E+02	-4.301694E+03 -3.356405E+03	1.623093E+03 1.908553E+03
84	-3.103515E+03 -3.046014E+03	-3.714646E+03 -4.251133E+03	-5.095109E+02 -3.715965E+02	-29.5240 -15.8310	-2.814966E+03 -2.940646E+03	-4.003194E+03 -4.359501E+03	5.341140E+02 7.079279E+02
85	-8.705862E+01 2.306522E+01	-2.888553E+03 -3.072020E+03	2.091965E+03 2.052896E+03	28.1115 26.4949	1.030485E+03 1.046373E+03	-4.003075E+03 -4.095327E+03	2.516790E+03 2.570950E+03
86	4.150193E+03 2.826303E+03	8.558350E+02 -1.697527E+02	-7.637811E+03 -6.855770E+03	-38.9329 -38.8371	1.022037E+04 0.345801E+03	-5.304342E+03 -5.68251E+03	7.8123156E+03 7.017526E+03
87	5.849748E+03 4.721362E+03	1.730653E+03 1.643970E+03	-7.432129E+03 -7.372409E+03	-38.7064 -39.1055	1.100536E+04 1.071393E+04	-4.224956E+03 -4.348603E+03	7.615159E+03 7.531266E+03
88	4.471339E+03 4.186620E+03	9.211348E+00 -7.748738E+00	-4.771450E+03 -4.572961E+03	-32.4699 -32.6818	7.507568E+03 7.120361E+03	-3.0027918E+03 -2.941482E+03	5.267293E+03 5.030921E+03
89	7.305504E+03 6.242923E+03	1.957380E+03 -3.343610E+02	-7.266992E+03 -6.744680E+03	-34.8989 -32.0033	1.237401E+04 1.845800E+04	-3.111928E+03 -6.549443E+03	7.743370E+03 7.503724E+03
100	6.457297E+03 7.232659E+03	3.894797E+02 1.742417E+03	-2.691530E+03 -1.679806E+03	-20.6028 -15.7323	7.669125E+03 7.705878E+03	-7.023489E+02 1.269195E+03	4.005737E+03 3.218339E+03
101	8.078044E+04 1.162017E+04	-1.200185E+03 3.943999E+03	-3.992142E+03 -3.941948E+03	-16.8404 -22.8675	1.198886E+04 1.329068E+04	-2.403565E+03 2.281488E+03	7.198686E+03 5.504995E+03
102	-3.630752E+03 -5.088845E+03	9.516273E+02 -4.214669E+02	-5.567671E+02 -2.457070E+02	-83.1942 -86.9933	1.037839E+03 -4.085511E+02	-3.596964E+03 -5.160955E+03	2.357401E+03 2.346202E+03
103	-2.225293E+03 -2.292843E+03	-7.524255E+01 -3.632063E+02	1.056498E+02 1.052692E+03	87.1935 66.2531	-7.806337E+01 9.992888E+01	-2.230393E+03 -2.155971E+03	1.080168E+03 1.627950E+03

CALC ONLY

ELEMENT ID.	FIBRE DISTANCE	STRESSES IN ELEMENT		GENERAL TRIANGULAR ELEMENTS (C T R I A 2)		PRINCIPAL STRESSES (ZERO SHEAR)		MINOR SHEAR
		NORMAL-X	NORMAL-Y	ANGLE	MAJOR	MINOR	SHEAR	
104	-3.60000E-02 3.60000E-02	-1.986814E+03 -1.565843E+03	3.510136E+02 -4.474910E+02	-75.4323 -83.5855	5.203380E+02 -4.331750E+02	-2.156142E+03 -1.580159E+03	1.336240E+03 5.734918E+02	
105	-3.60000E-02 3.60000E-02	-2.552747E+03 -2.950682E+03	-3.212276E+03 -4.398483E+03	-39.3777 -31.3659	-1.191393E+03 -2.094550E+03	-4.573629E+03 -5.254616E+03	1.691118E+03 1.580033E+03	
116	-4.00000E-02 4.00000E-02	-1.102163E+03 -1.392400E+03	-1.924850E+03 -1.769993E+03	32.7936 37.4739	-5.162630E+02 -8.542164E+02	-2.508751E+03 -2.308177E+03	9.952438E+02 7.269804E+02	
117	-4.00000E-02 4.00000E-02	-1.994603E+03 -1.181676E+03	-8.217836E+02 1.947792E+03	-74.9160 -68.3585	-7.299143E+02 2.532487E+03	-2.086473E+03 -1.766371E+03	6.782791E+02 2.149429E+03	
119	-4.00000E-02 4.00000E-02	-1.004410E+03 -2.348289E+03	-3.291558E+02 1.349681E+03	-70.5079 -74.7196	-2.324347E+02 1.647955E+03	-1.101131E+03 -2.646563E+03	4.343480E+02 2.147259E+03	
119	-4.00000E-02 4.00000E-02	-3.433842E+03 3.967484E+02	-2.289774E+03 3.837558E+03	-69.6839 -66.7645	-2.108047E+03 4.615125E+03	-3.645570E+03 -3.848186E+02	7.537615E+02 2.497972E+03	
120	-4.00000E-02 4.00000E-02	-1.976191E+03 -2.069119E+03	4.326733E+02 3.089884E+02	-65.0122 -80.7651	1.101052E+03 3.735623E+02	-2.6444570E+03 -2.133693E+03	1.972811E+03 1.253627E+03	
121	-4.00000E-02 4.00000E-02	-6.512333E+02 -2.680405E+03	8.706702E+02 2.136737E+02	-64.7058 -79.0455	1.308282E+03 3.263186E+02	-1.088845E+03 -2.793050E+03	1.198563E+03 1.559685E+03	
122	-4.00000E-02 4.00000E-02	4.999542E+02 1.021022E+02	9.455878E+02 -9.092872E+02	53.3208 5.9943	1.500805E+03 1.133777E+02	-5.526298E+01 -9.205827E+02	7.740340E+02 5.169702E+02	
123	-4.00000E-02 4.00000E-02	-9.405578E+02 -1.316776E+03	1.102364E+03 9.508393E+02	-88.6108 89.6273	1.103566E+03 9.509352E+02	-9.417592E+02 -1.316872E+03	1.1226663E+03 1.133904E+03	
124	-4.00000E-02 4.00000E-02	-4.644303E+02 -4.822141E+02	1.250760E+03 1.074017E+03	-62.0874 -61.1161	1.919896E+03 1.754821E+03	-1.133565E+03 -1.163019E+03	1.526730E+03 1.458920E+03	
125	-4.00000E-02 4.00000E-02	-4.744982E-01 5.754558E+02	-2.634582E+02 2.177131E+02	42.3181 40.1209	1.274689E+03 1.451925E+03	-1.538622E+03 -6.587558E+02	1.406655E+03 1.055340E+03	
126	-4.00000E-02 4.00000E-02	-1.794086E+02 -8.801890E+01	1.930617E+03 1.783242E+03	76.7343 75.9959	2.054798E+03 1.907359E+03	-3.035890E+02 -2.121354E+02	1.179193E+03 1.059747E+03	
127	-4.00000E-02 4.00000E-02	-1.641051E+02 -1.290225E+02	1.958631E+03 1.804943E+03	86.8917 88.5417	1.964909E+03 1.806198E+03	-1.713834E+02 -1.302764E+02	1.067646E+03 9.682372E+02	
128	-4.00000E-02 4.00000E-02	1.195142E+02 -1.503111E+02	8.177430E+02 6.845816E+02	-85.2631 83.7834	8.225704E+02 6.946069E+02	1.146869E+02 -1.603363E+02	3.539418E+02 4.274716E+02	
129	-4.00000E-02 4.00000E-02	4.273227E+02 1.597662E+02	1.812892E+03 1.561814E+03	-68.5637 -68.2830	2.065412E+03 1.826166E+03	1.748028E+02 -1.045863E+02	9.453046E+02 9.653762E+02	

CALC ONLY

ELEMENT ID.	FIBRE DISTANCE	STRESSES IN ELEMENT COORD SYSTEM		T R I A N G U L A R E L E M E N T S (C T R I A 2)		ANGLE	PRINCIPAL STRESSES (ZERO SHEAR)		MAX SHEAR
		NORMAL-X	NORMAL-Y	SHEAR-XY	MAJOR		MINOR		
130	-4.00000E-02 4.00000E-02	3.901279E+02 3.235688E+02	6.838560E+02 6.282400E+02	-6.071550E+02 -7.563918E+02	-6.767292E+01 -2.926850E+02	-51.7990 -50.6024	1.161557E+03 1.249494E+03	-8.767292E+01 -2.926850E+02	6.246649E+02 7.710897E+02
131	-6.00000E-02 6.00000E-02	3.537753E+02 4.481963E+02	7.011069E+02 8.633377E+02	-7.220384E+02 -1.074666E+03	-2.151596E+02 -4.387614E+02	-51.7623 -50.4660	1.270042E+03 1.750295E+03	-2.151596E+02 -4.387614E+02	7.426008E+02 1.094528E+03
132	-6.00000E-02 6.00000E-02	2.592466E+02 3.009903E+02	-1.906545E+01 -1.787677E+02	-5.502368E+02 -8.064697E+02	-6.474700E+02 -7.803133E+02	-37.9037 -36.7193	6.876511E+02 9.024359E+02	-6.474700E+02 -7.803133E+02	5.675605E+02 8.413746E+02
133	-6.00000E-02 6.00000E-02	2.806295E+02 2.502271E+02	-3.151085E+02 2.915332E+01	-1.875370E+02 -3.249964E+02	-3.692129E+02 -2.035897E+02	-16.0928 -35.6080	3.349339E+02 4.829701E+02	-3.692129E+02 -2.035897E+02	3.520734E+02 3.432799E+02
134	-6.00000E-02 6.00000E-02	3.959775E+02 -2.401959E+02	-2.434521E+02 -3.908959E+02	-5.023588E+02 -4.548534E+02	-5.192051E+02 -7.765982E+02	-28.7631 -40.2970	6.717305E+02 1.455065E+02	-5.192051E+02 -7.765982E+02	5.954678E+02 4.610524E+02
135	-4.50000E-02 4.50000E-02	3.618037E+03 3.771640E+03	1.103985E+04 1.150983E+04	7.715747E+03 7.920577E+03	1.589069E+04 1.645580E+04	57.8427 58.0174	1.589069E+04 1.645580E+04	-1.232808E+03 -1.174333E+03	8.561750E+03 8.815069E+03
136	-4.50000E-02 4.50000E-02	1.518825E+03 9.827726E+02	6.748487E+03 5.699267E+03	1.707166E+03 9.737973E+02	7.256436E+03 5.892413E+03	73.4302 78.7813	7.256436E+03 5.892413E+03	1.010876E+03 7.896259E+02	3.122780E+03 2.551394E+03
137	-4.50000E-02 4.50000E-02	1.591769E+03 1.428006E+03	5.807721E+03 5.431125E+03	6.066223E+03 5.341565E+03	1.014068E+04 9.133823E+03	54.5518 55.2708	1.014068E+04 9.133823E+03	-2.744192E+03 -2.274692E+03	6.440937E+03 5.704257E+03
138	-4.50000E-02 4.50000E-02	1.449879E+03 -5.004788E+02	4.288361E+03 3.137365E+03	4.536587E+03 3.721530E+03	7.622245E+03 5.460556E+03	53.6883 58.0252	7.622245E+03 5.460556E+03	-1.834805E+03 -2.824170E+03	4.753525E+03 4.142363E+03
139	-4.50000E-02 4.50000E-02	1.543912E+02 3.618745E+01	3.685232E+03 3.291761E+03	3.802350E+03 3.103700E+03	6.112016E+03 5.168635E+03	57.4527 58.8378	6.112016E+03 5.168635E+03	-2.272392E+03 -1.840697E+03	4.192204E+03 3.504661E+03
140	-4.50000E-02 4.50000E-02	2.820529E+03 3.647066E+03	-2.372196E+03 2.040714E+03	-3.423893E+03 -3.150959E+03	4.521158E+03 6.095602E+03	-26.4133 -37.8499	4.521158E+03 6.095602E+03	-4.072826E+03 -4.078224E+02	4.296992E+03 3.251712E+03
141	-3.60000E-02 3.60000E-02	-5.740744E+03 -5.131628E+03	-1.078290E+03 1.190547E+03	-9.114242E+02 -2.470804E+02	-9.064561E+02 1.200189E+03	-79.3232 -87.7693	-9.064561E+02 1.200189E+03	-5.912578E+03 -5.141270E+03	2.503061E+03 3.170729E+03
142	-3.60000E-02 3.60000E-02	-3.045895E+03 -3.053358E+03	-9.764813E+03 -1.054060E+04	-5.010912E+03 -5.269092E+03	-3.725106E+02 -3.333869E+02	-28.0805 -27.3033	-3.725106E+02 -3.333869E+02	-1.243820E+04 -1.326058E+04	6.032843E+03 6.463359E+03
143	-2.00000E-02 2.00000E-02	2.569034E+03 2.566056E+03	-8.017953E+02 -9.048319E+02	4.648597E+01 1.270099E+02	2.669656E+03 2.564707E+03	.7672 2.8965	2.669656E+03 2.564707E+03	-8.024178E+02 -9.094814E+02	1.736037E+03 1.737994E+03
144	-2.00000E-02 2.00000E-02	1.960863E+03 1.680951E+03	-4.297134E+02 -4.803177E+02	7.366464E+02 1.016554E+03	2.169627E+03 2.083945E+03	15.8226 21.6249	2.169627E+03 2.083945E+03	-6.384771E+02 -8.833119E+02	1.404052E+03 1.483629E+03
147	-3.60000E-02 3.60000E-02	-5.027436E+03 -5.361228E+03	-2.032172E+03 -1.055372E+03	3.599181E+02 3.480795E+02	-1.989530E+03 -1.027415E+03	83.2433 85.4080	-1.989530E+03 -1.027415E+03	-5.070078E+03 -5.389184E+03	1.540274E+03 2.180884E+03

CALC ONLY

ELEMENT ID.	FIBRE DISTANCE	STRESSES IN ELEMENT COORD SYSTEM		ANGLE	PRINCIPAL STRESSES (ZERO SHEAR)		MAX SHEAR	
		NORMAL-X	NORMAL-Y		MAJOR	MINOR		
148	-3.60000E-02	-1.478242E+03	-5.335445E+03	-1.151604E+02	-1.7086	-1.474806E+03	-5.338800E+03	1.932037E+03
	3.60000E-02	4.494420E+02	-4.335335E+03	-5.797788E+02	-6.8113	5.186922E+02	-4.404805E+03	2.461648E+03
149	-3.60000E-02	-4.237826E+03	-5.734176E+03	1.098017E+03	27.8650	-3.657315E+03	-6.314687E+03	1.328686E+03
	3.60000E-02	2.877556E+03	-2.146267E+03	1.134565E+03	12.1537	3.121899E+03	-2.398610E+03	2.756254E+03
150	-6.40000E-02	-3.657091E+03	-3.326849E+01	-2.331360E+03	-63.9270	1.107490E+03	-4.797850E+03	2.952670E+03
	6.40000E-02	-9.062262E+02	1.996868E+02	-2.830469E+03	-50.5269	2.530714E+03	-3.237234E+03	2.883974E+03
151	-6.40000E-02	-3.862059E+03	-2.921423E+02	-5.782709E+02	-81.0246	-2.008082E+02	-3.953393E+03	1.876292E+03
	6.40000E-02	-8.943464E+02	-4.048239E+01	-1.126663E+03	-55.3767	7.374256E+02	-1.672254E+03	1.204840E+03
153	-3.60000E-02	-2.855756E+03	-1.461663E+03	7.853692E+02	65.7952	-1.108624E+03	-3.208794E+03	1.850085E+03
	3.60000E-02	3.490068E+03	-3.745913E+02	6.647313E+02	9.4917	3.601207E+03	-4.057307E+02	2.043469E+03
154	-3.60000E-02	-3.778894E+03	-2.143416E+03	8.656292E+02	66.3588	-1.755735E+03	-4.166574E+03	1.205119E+03
	3.60000E-02	-9.813427E+01	-7.665793E+02	8.610594E+02	34.3931	4.912925E+02	-1.356006E+03	9.236493E+02
155	-3.60000E-02	3.775011E+03	-6.091672E+03	-3.291525E+03	-16.8556	4.772268E+03	-7.088929E+03	5.930598E+03
	3.60000E-02	8.501429E+03	7.226167E+03	-4.568006E+03	-41.0268	1.247609E+04	3.251504E+03	4.642234E+03
156	-8.00000E-02	4.466807E+03	7.650374E+03	3.298699E+02	84.1101	7.684404E+03	4.452777E+03	1.615813E+03
	8.00000E-02	-2.022120E+03	-8.609494E+03	-7.524271E+02	-6.4341	-1.937268E+03	-8.694345E+03	3.378538E+03
157	-6.40000E-02	1.135134E+03	7.810009E+02	-8.294827E+02	-38.9883	1.806555E+03	1.103798E+02	8.480876E+02
	6.40000E-02	7.741539E+02	8.328294E+02	-5.769157E+02	-46.4556	1.381153E+03	2.258305E+02	5.776612E+02
158	-4.00000E-03	-1.847050E+04	-6.158817E+03	-1.301043E+03	-84.0331	-6.022830E+03	-1.860649E+04	6.291830E+03
	4.00000E-03	-1.872748E+04	-6.232267E+03	-1.473440E+03	-83.3647	-6.061271E+03	-1.869888E+04	6.418804E+03
159	-4.00000E-03	-1.022588E+04	-3.389810E+03	4.386177E+03	63.9642	-1.247133E+03	-1.236855E+04	5.560710E+03
	4.00000E-03	-1.029955E+04	-3.410609E+03	4.355893E+03	64.1679	-1.301897E+03	-1.240826E+04	5.553181E+03
160	-4.00000E-03	-9.922287E+03	-2.405521E+03	9.988184E+03	55.3102	4.507987E+03	-1.683580E+04	1.067199E+04
	4.00000E-03	-9.950444E+03	-2.417046E+03	9.861012E+03	55.4529	4.372181E+03	-1.673987E+04	1.055593E+04
161	-4.00000E-03	-1.470450E+04	-3.972414E+03	7.081008E+03	63.5776	-4.539149E+02	-1.822300E+04	8.884543E+03
	4.00000E-03	-1.465747E+04	-3.945451E+03	7.096033E+03	63.5226	-4.109873E+02	-1.818191E+04	8.890475E+03
162	-4.00000E-03	-1.504373E+04	-4.650192E+03	7.179975E+03	52.9352	-9.915715E+02	-1.871235E+04	8.860391E+03
	4.00000E-03	-1.474751E+04	-4.558469E+03	7.294512E+03	62.4653	-7.555715E+02	-1.855041E+04	8.89717E+03
163	-4.00000E-03	-1.718338E+04	-4.521252E+03	5.463592E+03	69.6032	-2.489708E+03	-1.921492E+04	8.362806E+03
	4.00000E-03	-1.712158E+04	-4.492964E+03	5.468749E+03	69.5523	-2.453967E+03	-1.916058E+04	8.353306E+03
164	-4.00000E-02	-2.517914E+02	-1.142714E+03	-2.771689E+02	-15.9447	-1.726062E+02	-1.221839E+03	5.246463E+02
	4.00000E-02	-4.599380E+02	-1.869085E+03	-8.622418E+02	-25.3732	-5.101035E+01	-2.278012E+03	1.113501E+03

NADC-77149-30

CALC ONLY

STRESSES IN GENERAL TRIANGULAR ELEMENTS (CONTINUED)

ELEMENT ID.	FIBRE DISTANCE	STRESSES IN ELEMENT COORD SYSTEM		ANGLE	PRINCIPAL STRESSES (ZERO SHEAR)		MAX SHEAR
		NORMAL-X	NORMAL-Y		MAJOR	MINOR	
165	-4.00000E-02 4.00000E-02	-1.066271E+03 -1.086074E+03	4.849661E+02 1.886385E+03	-83.6920 -71.1212	5.041513E+02 2.280012E+03	-1.085956E+03 -1.479701E+03	7.948037E+02 1.879956E+03
174	-6.40000E-02 6.40000E-02	6.130059E+03 4.313469E+03	1.590862E+03 -1.230047E+03	14.1242 11.0525	6.430144E+03 4.533370E+03	1.390777E+03 -1.449946E+03	2.519694E+03 2.991659E+03
175	-6.40000E-02 6.40000E-02	4.412272E+02 -3.840360E+01	8.764463E+03 7.226923E+03	-64.8186 -87.7085	8.833470E+03 7.238576E+03	3.722202E+02 -5.003630E+01	4.230625E+03 3.644316E+03
176	-6.40000E-02 6.40000E-02	1.260158E+03 1.290793E+03	7.386574E+03 8.197650E+03	-74.4731 -75.3436	7.899022E+03 8.704759E+03	7.477099E+02 7.836844E+02	3.575656E+03 3.960537E+03
177	-6.40000E-02 6.40000E-02	7.350426E+02 7.208697E+02	1.015724E+04 9.843525E+03	-86.7807 -87.0842	1.018865E+04 9.867253E+03	7.036281E+02 6.921417E+02	4.742513E+03 4.585056E+03
178	-6.40000E-02 6.40000E-02	1.469514E+03 1.596751E+03	9.449437E+03 1.012204E+04	-86.1196 -86.0195	9.486322E+03 1.016352E+04	1.432629E+03 1.555271E+03	4.026847E+03 4.430124E+03
185	-1.90000E-01 1.90000E-01	-3.230525E+03 -2.996671E+03	5.117259E+03 5.186377E+03	-80.7456 -80.9755	5.344928E+03 5.398132E+03	-3.458194E+03 -3.200425E+03	4.401561E+03 4.430327E+03
186	-1.25000E-01 1.25000E-01	-1.209599E+03 1.358339E+03	3.463804E+03 1.016735E+04	74.8251 -86.3127	3.834975E+03 1.020409E+04	-1.580690E+03 1.321601E+03	2.707832E+03 4.441245E+03
187	-3.15000E-02 3.15000E-02	-2.620173E+03 5.305700E+03	1.506106E+04 1.767450E+04	-58.5101 -54.6054	2.568014E+04 3.028515E+04	-1.323925E+04 -7.304949E+03	1.945959E+04 1.879505E+04
188	-3.15000E-02 3.15000E-02	-4.938435E+03 -5.333893E+03	-3.033431E+03 -3.497233E+03	47.2255 46.9554	8.287720E+03 9.048688E+03	-1.625959E+04 -1.707981E+04	1.227365E+04 1.346+25E+04
189	-3.15000E-02 3.15000E-02	-1.082777E+03 6.779134E+03	1.413351E+04 1.672563E+04	-71.0414 -63.5899	1.616936E+04 1.998188E+04	-3.118627E+03 3.522877E+03	9.643995E+03 8.229503E+03
190	-3.15000E-02 3.15000E-02	-3.326289E+03 -2.689784E+03	-2.302342E+03 -2.324867E+03	47.1178 45.6753	4.117595E+03 5.193294E+03	-9.746226E+03 -1.020601E+04	6.931910E+03 7.699651E+03
191	-3.15000E-02 3.15000E-02	-9.073114E+02 5.269995E+03	1.045431E+04 1.248853E+04	-74.5724 -64.4425	1.139089E+04 1.462871E+04	-1.843900E+03 3.129819E+03	6.617397E+03 5.7494+3E+03
192	-3.15000E-02 3.15000E-02	-1.683951E+03 -1.536395E+03	-1.699741E+01 -1.704264E+01	51.5703 50.9487	2.810327E+03 2.908152E+03	-4.513275E+03 -4.461590E+03	3.661801E+03 3.684871E+03
193	-6.25000E-02 6.25000E-02	5.022663E+02 5.022663E+02	3.454240E+03 3.454240E+03	-68.1933 -68.1933	3.457180E+03 3.457180E+03	4.993262E+02 4.993262E+02	1.478927E+03 1.478927E+03
194	-4.90000E-02 4.90000E-02	-1.578265E+04 -1.586852E+04	-7.582016E+02 -2.022603E+03	-83.6014 -83.3871	-5.668488E+02 -1.833973E+03	-1.597400E+04 -1.605715E+04	7.703578E+03 7.111586E+03

CALC ONLY

ELEMENT ID.	FIBRE DISTANCE	STRESSES		GENERAL TRIANGULAR ELEMENTS (CYRIA 2)		PRINCIPAL STRESSES (ZERO SHEAR)		MAX SHEAR
		NORMAL-X	NORMAL-Y	SHEAR-XY	ANGLE	MAJOR	MINOR	
195	-4.90000E-02	-1.048172E+04	-3.329351E+03	9.628746E+03	55.1877	3.365875E+03	-1.717694E+04	1.027141E+04
	4.90000E-02	-9.094426E+03	-2.889430E+03	1.067011E+04	53.1063	5.120079E+03	-1.710393E+04	1.111201E+04
196	-4.90000E-02	-1.014665E+04	-2.034426E+03	6.069727E+03	61.0765	1.209712E+03	-1.339078E+04	7.300247E+03
	4.90000E-02	-8.528066E+03	-1.452750E+03	5.766535E+03	60.7642	1.774793E+03	-1.175561E+04	6.765201E+03
197	-4.90000E-02	-1.926382E+03	-2.864622E+03	7.191075E+02	28.4366	-1.536688E+03	-3.254035E+03	8.586737E+02
	4.90000E-02	-1.950415E+03	-2.507828E+03	3.841777E+02	27.0203	-1.754496E+03	-2.703747E+03	4.746259E+02
198	-4.90000E-02	1.980659E+03	8.933360E+02	3.753560E+03	40.9018	5.232296E+03	-2.352300E+03	3.792298E+03
	4.90000E-02	2.409191E+03	9.899494E+02	3.470732E+03	39.2223	5.242103E+03	-1.842963E+03	3.542533E+03
199	-4.90000E-02	1.633852E+03	-8.805215E+01	2.486074E+03	35.4441	3.403496E+03	-1.858695E+03	2.631095E+03
	4.90000E-02	2.317561E+03	6.497419E+02	2.868800E+03	36.8959	4.471196E+03	-1.503893E+03	2.987544E+03
200	-4.90000E-02	7.323254E+03	-1.464580E+03	-1.031018E+03	-6.6027	7.442595E+03	-1.583922E+03	4.513259E+03
	4.90000E-02	7.551793E+03	-1.505367E+03	-6.553406E+02	-4.1171	7.598965E+03	-1.552539E+03	4.575752E+03
201	-4.90000E-02	7.518726E+03	1.525758E+03	2.149177E+03	17.8247	8.209773E+03	8.347120E+02	3.687530E+03
	4.90000E-02	8.496065E+03	-1.041932E+03	1.727656E+03	9.9569	8.799358E+03	-1.345225E+03	5.072292E+03
202	-4.90000E-02	1.121688E+04	-7.613204E+02	-7.845578E+02	-3.7316	1.126805E+04	-8.124894E+02	6.040272E+03
	4.90000E-02	1.139831E+04	-6.612555E+02	-5.376817E+02	-2.5482	1.142024E+04	-6.851848E+02	6.052712E+03
203	-4.90000E-02	1.240093E+04	3.308164E+03	8.588492E+02	5.3488	1.248134E+04	3.227754E+03	4.626734E+03
	4.90000E-02	1.291475E+04	3.458620E+03	7.906600E+02	4.7468	1.298041E+04	3.392966E+03	4.793720E+03
204	-4.90000E-02	1.444154E+04	-7.479213E+02	-4.514098E+02	-1.7808	1.445495E+04	-7.613248E+02	7.608135E+03
	4.90000E-02	1.484052E+04	3.019056E+02	-3.526602E+02	-1.3887	1.484907E+04	2.933562E+02	7.277857E+03
205	-2.50000E-02	-2.205709E+03	-6.351423E+02	3.721358E+02	77.3222	-5.514291E+02	-2.289422E+03	8.689366E+02
	2.50000E-02	-2.125811E+03	-5.899997E+02	4.235670E+02	75.5597	-4.809287E+02	-2.234882E+03	8.769766E+02
206	-2.50000E-02	-2.721810E+03	1.960929E+03	5.286944E+02	83.6378	2.019878E+03	-2.780759E+03	2.400319E+03
	2.50000E-02	-2.528791E+03	1.354862E+03	5.127432E+02	82.6043	1.421417E+03	-2.595346E+03	2.008381E+03
207	-2.50000E-02	-3.543823E+03	-1.191191E+03	-1.585568E+03	-63.2857	-3.932363E+02	-4.341777E+03	1.974271E+03
	2.50000E-02	-3.590734E+03	-1.201975E+03	-1.711774E+03	-62.4526	-3.090805E+02	-4.463629E+03	2.087274E+03
208	-2.50000E-02	-2.240315E+03	2.169925E+03	-9.074767E+02	-78.8156	2.349352E+03	-2.419743E+03	2.384548E+03
	2.50000E-02	-2.604468E+03	1.930399E+03	-1.333951E+03	-74.7656	2.293685E+03	-2.967746E+03	2.630716E+03
209	-2.50000E-02	-7.230383E+02	-4.579719E+03	-4.505634E+03	-33.4149	2.249563E+03	-7.552320E+03	4.900342E+03
	2.50000E-02	-6.113865E+02	-4.223762E+03	-4.252167E+03	-33.4929	2.202300E+03	-7.037449E+03	4.613875E+03
210	-2.50000E-02	-1.746263E+03	-1.216277E+03	-3.159512E+03	-47.3971	1.689335E+03	-4.651875E+03	3.170605E+03
	2.50000E-02	-5.080804E+02	2.068900E+03	-2.921467E+03	-56.8998	3.973399E+03	-2.412578E+03	3.192988E+03

NADC-77149-30

CALC ONLY

ELEMENT ID.	STRESS FIBRE DISTANCE	TENSILE STRESSES		NORMAL STRESSES IN ELEMENT COORD SYSTEM		SHEAR-XY	ANGLE	PRINCIPAL STRESSES (ZERO SHEAR)		MAX SHEAR
		NORMAL-X	NORMAL-Y	NORMAL-X	NORMAL-Y			MAJOR	MINOR	
211	-2.000000E-02	-1.238737E+03	-4.280582E+01	-6.277251E+03	-47.7208	5.664896E+03	-6.946439E+03	6.305667E+03	6.182774E+03	
	2.000000E-02	-1.339698E+03	-6.666585E+01	-6.150948E+03	-47.9090	5.469592E+03	-6.895955E+03	6.182774E+03		
212	-2.000000E-02	3.044933E+02	8.917941E+02	-4.822001E+03	-46.7424	5.429078E+03	-4.232791E+03	4.830335E+03	4.591871E+03	
	2.000000E-02	-6.869466E+01	-2.123836E+02	-4.691320E+03	-44.5613	4.551331E+03	-4.832410E+03	4.591871E+03		
213	-2.000000E-02	1.832428E+02	7.645380E+02	-6.969838E+03	-46.1939	7.449786E+03	-6.502005E+03	6.975896E+03	6.962919E+03	
	2.000000E-02	3.405333E+02	7.877132E+02	-6.959329E+03	-45.9200	7.527072E+03	-6.398766E+03	6.962919E+03		
214	-2.000000E-02	2.736639E+03	8.966996E+02	-5.163908E+03	-39.9493	7.061886E+03	-3.428547E+03	5.245216E+03	5.33017E+03	
	2.000000E-02	2.336646E+03	-1.750991E+01	-5.198830E+03	-38.6213	6.489985E+03	-4.170849E+03	5.33017E+03		
215	-2.000000E-02	2.250995E+02	2.317085E+03	6.788151E+03	49.3799	8.139360E+03	-5.597175E+03	6.868268E+03	7.495150E+03	
	2.000000E-02	4.493324E+02	2.688630E+03	7.411059E+03	49.2956	9.064131E+03	-5.926169E+03	7.495150E+03		
216	-2.000000E-02	-4.549587E+02	4.275905E+03	3.353498E+03	62.5989	6.014278E+03	-2.193332E+03	4.103805E+03	4.137973E+03	
	2.000000E-02	-3.544077E+02	4.252502E+03	3.437574E+03	61.9127	6.087020E+03	-2.168926E+03	4.137973E+03		
217	-2.000000E-02	5.467467E+03	1.954245E+03	-4.645112E+03	-34.6426	8.677017E+03	-1.255305E+03	4.966161E+03	4.736204E+03	
	2.000000E-02	5.816995E+03	2.051791E+03	-4.345968E+03	-33.2093	8.670598E+03	-8.018111E+02	4.966161E+03	4.736204E+03	
218	-2.000000E-02	4.697302E+03	-1.073540E+03	-7.224896E+02	-7.0287	4.786381E+03	-1.162619E+03	2.974500E+03	2.696832E+03	
	2.000000E-02	4.743432E+03	-5.074763E+02	-6.163538E+02	-6.6058	4.814809E+03	-5.788559E+02	2.696832E+03		
219	-2.000000E-02	3.137029E+03	6.854731E+02	7.735514E+02	16.1274	3.360704E+03	4.617983E+02	1.449453E+03	1.617306E+03	
	2.000000E-02	3.107942E+03	6.863239E+02	1.073111E+03	20.7749	3.515041E+03	2.792252E+02	1.617306E+03		
220	-2.000000E-02	6.240895E+03	-7.319116E+03	2.849547E+03	11.3982	6.815371E+03	-7.093592E+03	7.354481E+03	8.176954E+03	
	2.000000E-02	4.930906E+03	-9.900139E+03	3.445664E+03	12.4811	5.692333E+03	-1.066157E+04	8.176954E+03		
221	-2.000000E-02	8.337412E+03	-9.440458E+02	-6.185201E+03	-26.5596	1.142928E+04	-4.035915E+03	7.732598E+03	7.675658E+03	
	2.000000E-02	7.908603E+03	-8.988022E+02	-6.286742E+03	-27.4949	1.118056E+04	-4.170757E+03	7.675658E+03		
222	-2.000000E-02	2.555161E+03	1.572137E+03	1.071121E+04	43.6863	1.278613E+04	-8.65831E+03	1.072248E+04	1.111465E+04	
	2.000000E-02	3.145053E+03	3.428689E+03	1.111380E+04	45.3552	1.439752E+04	-7.831783E+03	1.111465E+04		
223	-2.000000E-02	-5.483819E+03	-4.396894E+03	-3.617270E+03	-49.2721	-1.282489E+03	-8.598224E+03	3.657868E+03	3.567532E+03	
	2.000000E-02	-5.532103E+03	-4.387067E+03	-3.521295E+03	-49.6173	-1.392063E+03	-8.527127E+03	3.567532E+03		
224	-2.000000E-02	7.047974E+02	1.452706E+01	6.617335E+02	31.2276	1.105993E+03	-3.866684E+02	7.463307E+02	7.889209E+02	
	2.000000E-02	6.207424E+02	-1.111297E+02	6.989185E+02	31.1823	1.043727E+03	-5.341146E+02	7.889209E+02		
225	-2.000000E-02	5.478146E+02	-5.165699E+02	-1.498664E+03	-35.2247	1.605976E+03	-1.574731E+03	1.590353E+03	1.723851E+03	
	2.000000E-02	3.498608E+02	-8.765915E+02	-1.611092E+03	-34.5809	1.460486E+03	-1.987217E+03	1.723851E+03		
226	-2.000000E-02	-1.336217E+02	-1.278240E+01	1.772927E+03	45.9759	1.780754E+03	-1.847158E+03	1.773356E+03	1.751577E+03	
	2.000000E-02	-2.841125E+02	-1.758569E+02	1.750741E+03	45.8854	1.521592E+03	-1.981562E+03	1.751577E+03		

NADC-77149-30

CALC ONLY

ELEMENT ID.	STRESSES IN GENERAL TRIA NGULAR ELEMENTS (C Y R I A 2)	STRESSES IN ELEMENT COORD SYSTEM		PRINCIPAL STRESSES (ZERO SHEAR)		MAX SHEAR		
		NORMAL-X	NORMAL-Y	MAJOR	MINOR			
227	-2.00000E-02 2.00000E-02	-2.543443E+03 -3.952985E+03	-2.735832E+03 -3.352865E+03	6.331357E+02 7.445843E+02	48.6805 55.9745	-1.999236E+03 -2.850153E+03	-3.280039E+03 -4.455696E+03	6.404016E+02 8.027713E+02
228	-2.00000E-02 2.00000E-02	-1.846263E+03 -1.243500E+03	1.577250E+03 2.418678E+03	-5.756026E+02 -7.833772E+02	-80.7070 -78.4189	1.671437E+03 2.579213E+03	-1.940449E+03 -1.404035E+03	1.805943E+03 1.991624E+03
229	-2.00000E-02 2.00000E-02	-2.360213E+03 -2.076325E+03	-4.237258E+02 3.385172E+02	8.634743E+02 4.417063E+02	69.1368 79.9531	-9.463231E+01 4.167750E+02	-2.689307E+03 -2.154583E+03	1.297337E+03 1.285679E+03
230	-2.00000E-02 2.00000E-02	-1.789477E+03 -1.931194E+03	-6.463204E+02 -5.104830E+01	-1.138962E+03 -1.472559E+03	-58.3247 -61.2770	5.643856E+01 7.559242E+02	-2.492236E+03 -2.738166E+03	1.274337E+03 1.747045E+03
231	-2.00000E-02 2.00000E-02	-1.686976E+03 -2.573332E+03	-1.319374E+03 -1.868069E+03	6.725835E+02 5.965102E+02	52.6422 60.2949	-8.059297E+02 -1.527755E+03	-2.200421E+03 -2.913646E+03	6.972456E+02 6.929455E+02

NADC-77149-30

CALC ONLY

ELEMENT ID.	STRESSES IN FIBRE DISTANCE	GENERAL QUADRILATERAL ELEMENTS (CQUAD1)			PRINCIPAL STRESSES (ZERO SHEAR)			MAX SHEAR
		NORMAL-X	NORMAL-Y	SHEAR-XY	ANGLE	MAJOR	MINOR	
200	8.10000E-01 -8.10000E-01	-2.198122E+02 7.837500E+01	-4.053065E+01 -2.441027E+01	-3.505149E+01 -6.154355E+00	-79.3217 -3.4178	-3.392136E+01 7.894256E+01	-2.264215E+02 -2.447283E+01	9.625006E+01 5.170769E+01
201	8.10000E-01 -8.10000E-01	-2.333338E+02 5.893912E+00	5.017040E+01 -1.373552E+02	-8.630206E+01 -2.527237E+01	-74.3212 -9.6552	7.441685E+01 1.119346E+01	-2.575802E+02 -1.416547E+02	1.559935E+02 7.642410E+01
202	8.10000E-01 -8.10000E-01	-6.670012E+02 4.771337E+02	4.521845E+01 -1.139263E+02	-2.821937E+01 2.070463E+01	-87.7346 2.0038	4.633480E+01 4.778501E+02	-6.681176E+02 -1.146507E+02	3.572262E+02 2.962544E+02
203	8.10000E-01 -8.10000E-01	-5.844474E+02 4.783151E+02	-9.077201E+01 6.536909E+01	-6.736825E+01 5.307687E+01	-83.6069 7.2083	-8.322361E+01 4.850280E+02	-6.920227E+02 5.865613E+01	3.043333E+02 2.131868E+02
204	8.10000E-01 -8.10000E-01	-6.192461E+02 4.635538E+02	5.897531E+02 -6.619293E+02	-2.623775E+01 3.999028E+01	-88.7573 2.0324	5.903223E+02 4.649729E+02	-6.198172E+02 -5.633484E+02	6.050597E+02 5.641607E+02
205	8.10000E-01 -8.10000E-01	-6.350261E+02 4.625585E+02	3.405915E+02 -3.627484E+02	-8.403654E+01 1.119133E+02	-85.1093 7.5869	3.477874E+02 4.774649E+02	-6.422220E+02 -3.776548E+02	4.950047E+02 4.275599E+02
206	8.10000E-01 -8.10000E-01	-3.204598E+02 2.219838E+02	1.440956E+03 -1.639762E+03	-1.983489E+01 6.750688E+01	-89.3549 2.0739	1.441179E+03 2.244284E+02	-3.206831E+02 -1.642206E+03	8.809310E+02 9.333174E+02
207	8.10000E-01 -8.10000E-01	-4.121309E+02 2.070800E+02	9.392796E+02 -1.105652E+03	-6.964457E+01 2.080608E+02	-87.0577 8.7945	9.428592E+02 2.391970E+02	-4.157105E+02 -1.137841E+03	6.792949E+02 6.885188E+02
208	8.10000E-01 -8.10000E-01	-1.024331E+02 1.165905E+02	2.173435E+03 -2.070976E+03	-7.644398E+01 8.833519E+01	-88.0784 2.3886	2.176000E+03 1.201517E+02	-1.049979E+02 -2.074537E+03	1.140439E+03 1.097344E+03
209	8.10000E-01 -8.10000E-01	-9.074993E+01 -2.801554E+02	2.659737E+03 -2.705190E+03	-5.245558E+02 7.729999E+02	-79.5609 16.2591	2.756301E+03 -5.471330E+01	-1.873942E+02 -2.930632E+03	1.471888E+03 1.437959E+03

NADC-77149-30

BQM-3 COMPOSITE FUSELAGE FINE GRID MODEL
FREE FLIGHT-5G

CALC ONLY

ELEMENT ID.	SA1		SA2		SA3		SA4		AXIAL STRESS		SA-MIN		SA-MAX		M.S.-T	
	SB1	SB2	SB2	SB2	SB3	SB3	SB4	SB4	SB-MIN	SB-MIN	SB-MIN	SB-MIN	SB-MAX	SB-MAX	M.S.-C	M.S.-C
1001	0.0	1.184247E+04	0.0	0.0	0.0	0.0	0.0	0.0	9.852386E+02	1.282771E+04	9.852386E+02	9.852386E+02	9.852386E+02	9.852386E+02	4.8E+00	4.8E+00
	0.0	-3.048016E+02	0.0	0.0	0.0	0.0	0.0	0.0	-1.552925E+03	9.852386E+02	-1.552925E+03	6.812369E+02	6.812369E+02	6.812369E+02	1.0E+01	1.0E+01
1002	0.0	6.520962E+02	0.0	0.0	0.0	0.0	0.0	0.0	-5.697240E+01	-9.008285E+02	-5.697240E+01	-1.552925E+03	-1.552925E+03	-1.552925E+03	1.0E+01	1.0E+01
	0.0	-1.932698E+03	0.0	0.0	0.0	0.0	0.0	0.0	5.339479E+02	-1.552925E+03	5.339479E+02	-3.485623E+03	-3.485623E+03	-3.485623E+03	1.0E+01	1.0E+01
1003	0.0	-2.899434E+04	0.0	0.0	-1.315610E+04	0.0	1.11989E+04	1.11989E+04	-5.697240E+01	1.114292E+04	-5.697240E+01	-2.905131E+04	-2.905131E+04	-2.905131E+04	5.7E+00	5.7E+00
	0.0	-3.982065E+03	0.0	0.0	-4.785675E+03	0.0	2.592382E+03	2.592382E+03	5.339479E+02	2.535409E+03	5.339479E+02	-0.959037E+03	-0.959037E+03	-0.959037E+03	1.2E+00	1.2E+00
1004	0.0	6.639779E+02	0.0	0.0	0.0	0.0	0.0	0.0	1.200105E+03	1.217926E+03	1.200105E+03	5.339479E+02	5.339479E+02	5.339479E+02	2.0E+01	2.0E+01
	0.0	3.114424E+03	0.0	0.0	0.0	0.0	0.0	0.0	8.632524E+02	3.648372E+03	8.632524E+02	5.339479E+02	5.339479E+02	5.339479E+02	5.4E+00	5.4E+00
1005	0.0	1.082872E+04	0.0	0.0	0.0	0.0	0.0	0.0	1.200105E+03	1.169197E+04	1.200105E+03	8.632524E+02	8.632524E+02	8.632524E+02	4.8E+00	4.8E+00
	0.0	-1.213195E+04	0.0	0.0	0.0	0.0	0.0	0.0	-1.022198E+03	8.632524E+02	-1.022198E+03	-1.126870E+04	-1.126870E+04	-1.126870E+04	4.8E+00	4.8E+00
1006	0.0	-4.522533E+01	0.0	0.0	-6.910765E+02	0.0	0.0	0.0	1.200105E+03	1.200105E+03	1.200105E+03	5.090289E+02	5.090289E+02	5.090289E+02	3.0E+01	3.0E+01
	0.0	1.194381E+03	0.0	0.0	-1.194699E+03	0.0	0.0	0.0	-1.022198E+03	2.394687E+03	-1.022198E+03	5.406696E+00	5.406696E+00	5.406696E+00	5.5E+01	5.5E+01
1007	0.0	1.932752E+01	0.0	0.0	0.0	0.0	0.0	0.0	8.511891E+02	-1.002870E+03	8.511891E+02	-1.022198E+03	-1.022198E+03	-1.022198E+03	2.2E+01	2.2E+01
	0.0	-1.487093E+02	0.0	0.0	0.0	0.0	0.0	0.0	-1.022198E+03	-1.022198E+03	-1.022198E+03	-1.170907E+03	-1.170907E+03	-1.170907E+03	7.9E+00	7.9E+00
1008	0.0	-8.129405E+03	0.0	0.0	0.0	0.0	0.0	0.0	8.511891E+02	8.511891E+02	8.511891E+02	-7.278216E+03	-7.278216E+03	-7.278216E+03	1.4E+00	1.4E+00
	0.0	2.477718E+03	0.0	0.0	0.0	0.0	0.0	0.0	8.511891E+02	3.328907E+03	8.511891E+02	-8.895429E+02	-8.895429E+02	-8.895429E+02	1.3E+00	1.3E+00
1009	0.0	-2.974249E+04	0.0	0.0	3.034308E+04	0.0	0.0	0.0	8.511891E+02	3.122771E+04	8.511891E+02	-2.885785E+04	-2.885785E+04	-2.885785E+04	1.4E+00	1.4E+00
	0.0	-1.774169E+03	0.0	0.0	1.809270E+03	0.0	0.0	0.0	-1.443434E+02	2.693896E+03	-1.443434E+02	-8.895429E+02	-8.895429E+02	-8.895429E+02	1.3E+00	1.3E+00
1010	0.0	-1.125165E+03	0.0	0.0	0.0	0.0	0.0	0.0	-1.443434E+02	-1.443434E+02	-1.443434E+02	-1.269508E+03	-1.269508E+03	-1.269508E+03	1.6E+02	1.6E+02
	0.0	5.963497E+02	0.0	0.0	0.0	0.0	0.0	0.0	4.520063E+02	4.520063E+02	4.520063E+02	-1.443434E+02	-1.443434E+02	-1.443434E+02	5.0E+01	5.0E+01
1011	0.0	-2.448401E+04	0.0	0.0	0.0	0.0	0.0	0.0	-1.782959E+02	-1.782959E+02	-1.782959E+02	-2.466231E+04	-2.466231E+04	-2.466231E+04	1.6E+00	1.6E+00
	0.0	-1.222059E+04	0.0	0.0	0.0	0.0	0.0	0.0	-4.597637E+02	-1.782959E+02	-4.597637E+02	-1.957851E+03	-1.957851E+03	-1.957851E+03	4.2E+00	4.2E+00
1012	0.0	-1.488087E+03	0.0	0.0	0.0	0.0	0.0	0.0	-4.597637E+02	-4.597637E+02	-4.597637E+02	-1.255066E+04	-1.255066E+04	-1.255066E+04	8.0E+00	8.0E+00
	0.0	-1.209089E+04	0.0	0.0	0.0	0.0	0.0	0.0	8.341316E+03	8.341316E+03	8.341316E+03	-9.373642E+03	-9.373642E+03	-9.373642E+03	5.9E+00	5.9E+00
1013	0.0	9.243335E+03	0.0	0.0	-6.465623E+03	0.0	0.0	0.0	1.234348E+02	8.341316E+03	1.234348E+02	-7.350580E+03	-7.350580E+03	-7.350580E+03	1.5E+01	1.5E+01
	0.0	1.245272E+01	0.0	0.0	-1.887190E+01	0.0	0.0	0.0	2.456634E+03	-8.955667E+02	2.456634E+03	-1.477738E+03	-1.477738E+03	-1.477738E+03	7.8E+00	7.8E+00
1014	0.0	2.034267E+02	0.0	0.0	-7.474015E+03	0.0	4.536029E+03	4.536029E+03	3.003910E+02	4.659464E+03	3.003910E+02	-3.411237E+03	-3.411237E+03	-3.411237E+03	4.9E+00	4.9E+00
	0.0	1.321845E+02	0.0	0.0	2.333199E+03	0.0	-1.601173E+03	-1.601173E+03	1.277622E+04	2.456634E+03	1.277622E+04	3.003910E+02	3.003910E+02	3.003910E+02	1.8E+01	1.8E+01
1015	0.0	-3.711629E+03	0.0	0.0	0.0	0.0	0.0	0.0	1.337740E+03	3.003910E+02	1.337740E+03	-0.768656E+03	-0.768656E+03	-0.768656E+03	5.4E+00	5.4E+00
	0.0	1.247583E+04	0.0	0.0	0.0	0.0	0.0	0.0	1.178897E+04	1.277622E+04	1.178897E+04	1.005522E+03	1.005522E+03	1.005522E+03	6.4E+00	6.4E+00
1016	0.0	-1.010640E+04	0.0	0.0	1.845123E+04	0.0	0.0	0.0	1.337740E+03	1.178897E+04	1.337740E+03	1.005522E+03	1.005522E+03	1.005522E+03	6.4E+00	6.4E+00
	0.0	-4.847807E+01	0.0	0.0	-3.322174E+02	0.0	0.0	0.0	1.337740E+03	1.178897E+04	1.337740E+03	1.005522E+03	1.005522E+03	1.005522E+03	6.4E+00	6.4E+00

NADC-77149-30

CALC ONLY

ELEMENT ID.	SA1		SA2		SA3		SA4		STRESS		C B A R		SA-MIN		M.S.-I	
	SBI	SB2	SBI	SB2	SBI	SB3	SBI	SB4	AXIAL	STRESS	SA-MAX	SB-MAX	SA-MIN	SB-MIN	M.S.-I	M.S.-C
1017	0.0	0.0	-3.322863E+04	3.398633E+04	0.0	0.0	0.0	0.0	1.206730E+02	3.410702E+04	-3.310796E+04	-3.310796E+04	-3.310796E+04	-3.310796E+04	1.2E+00	9.6E-01
	9.0	0.0	-9.930362E+03	1.036593E+04	0.0	0.0	0.0	0.0		1.048570E+04	-9.809689E+03	-9.809689E+03	-9.809689E+03	-9.809689E+03	9.6E-01	
1018	0.0	0.0	-1.099505E+02	-7.333153E+01	0.0	0.0	0.0	0.0	-1.769832E+03	-1.789832E+03	-1.699782E+03	-1.699782E+03	-1.699782E+03	-1.699782E+03	3.5E-01	1.1E-01
	0.0	0.0	-5.701676E+04	5.741797E+04	0.0	0.0	0.0	0.0		5.562814E+04	-5.880660E+04	-5.880660E+04	-5.880660E+04	-5.880660E+04	1.1E-01	
1019	0.0	0.0	3.210854E+02	3.367440E+02	0.0	0.0	0.0	0.0	-7.940445E+02	-4.572975E+02	-7.940445E+02	-7.940445E+02	-7.940445E+02	5.1E+02	4.1E+01	
	0.0	0.0	-7.473029E+02	9.405735E+02	0.0	0.0	0.0	0.0		1.465320E+02	-1.541344E+03	-1.541344E+03	-1.541344E+03	-1.541344E+03	4.1E+01	
1020	0.0	0.0	1.172574E+03	-1.492660E+03	0.0	0.0	0.0	0.0	-7.936956E+02	3.788790E+02	-2.286355E+03	-2.286355E+03	-2.286355E+03	-2.286355E+03	2.7E+01	2.5E+01
	0.0	0.0	-1.734806E+03	3.476908E+03	0.0	0.0	0.0	0.0		2.683213E+03	-2.528501E+03	-2.528501E+03	-2.528501E+03	-2.528501E+03	2.5E+01	
1021	0.0	0.0	-6.385935E+02	0.0	0.0	0.0	0.0	0.0	6.352805E+02	6.352805E+02	-3.304977E+00	-3.304977E+00	-3.304977E+00	-3.304977E+00	9.9E+01	2.0E+04
	0.0	0.0	1.149254E+02	0.0	0.0	0.0	0.0	0.0		7.502139E+02	6.352805E+02	6.352805E+02	6.352805E+02	6.352805E+02	2.0E+04	
1022	0.0	0.0	0.0	0.0	0.0	0.0	0.0	0.0	1.779500E+03	1.779500E+03	1.779500E+03	1.779500E+03	1.779500E+03	3.3E+01		
	0.0	0.0	0.0	0.0	0.0	0.0	0.0	0.0		1.779500E+03	1.779500E+03	1.779500E+03	1.779500E+03	1.779500E+03	3.3E+01	
1023	0.0	0.0	0.0	0.0	0.0	0.0	0.0	0.0	-3.184089E+03	-3.184089E+03	-3.184089E+03	-3.184089E+03	-3.184089E+03	1.1E+01		
	0.0	0.0	0.0	0.0	0.0	0.0	0.0	0.0		-3.184089E+03	-3.184089E+03	-3.184089E+03	-3.184089E+03	-3.184089E+03	1.1E+01	
1024	0.0	0.0	0.0	0.0	0.0	0.0	0.0	0.0	-1.483545E+03	-1.483545E+03	-1.483545E+03	-1.483545E+03	-1.483545E+03	2.5E+01		
	0.0	0.0	0.0	0.0	0.0	0.0	0.0	0.0		-1.483545E+03	-1.483545E+03	-1.483545E+03	-1.483545E+03	-1.483545E+03	2.5E+01	
1025	0.0	0.0	0.0	0.0	0.0	0.0	0.0	0.0	-3.332267E+03	-3.332267E+03	-3.332267E+03	-3.332267E+03	-3.332267E+03	1.0E+01		
	0.0	0.0	0.0	0.0	0.0	0.0	0.0	0.0		-3.332267E+03	-3.332267E+03	-3.332267E+03	-3.332267E+03	-3.332267E+03	1.0E+01	
1026	0.0	0.0	0.0	0.0	0.0	0.0	0.0	0.0	-2.102261E+03	-2.102261E+03	-2.102261E+03	-2.102261E+03	-2.102261E+03	1.7E+01		
	0.0	0.0	0.0	0.0	0.0	0.0	0.0	0.0		-2.102261E+03	-2.102261E+03	-2.102261E+03	-2.102261E+03	-2.102261E+03	1.7E+01	
1027	0.0	0.0	0.0	0.0	0.0	0.0	0.0	0.0	-4.446876E+03	-4.446876E+03	-4.446876E+03	-4.446876E+03	-4.446876E+03	7.5E+00		
	0.0	0.0	0.0	0.0	0.0	0.0	0.0	0.0		-4.446876E+03	-4.446876E+03	-4.446876E+03	-4.446876E+03	-4.446876E+03	7.5E+00	
1028	0.0	0.0	0.0	0.0	0.0	0.0	0.0	0.0	8.723300E+03	8.723300E+03	8.723300E+03	8.723300E+03	8.723300E+03	2.9E+00		
	0.0	0.0	0.0	0.0	0.0	0.0	0.0	0.0		8.723300E+03	8.723300E+03	8.723300E+03	8.723300E+03	8.723300E+03	2.9E+00	
1029	0.0	0.0	0.0	0.0	0.0	0.0	0.0	0.0	1.687033E+04	1.687033E+04	1.687033E+04	1.687033E+04	1.687033E+04	1.0E+00		
	0.0	0.0	0.0	0.0	0.0	0.0	0.0	0.0		1.687033E+04	1.687033E+04	1.687033E+04	1.687033E+04	1.687033E+04	1.0E+00	
1030	0.0	0.0	0.0	0.0	0.0	0.0	0.0	0.0	2.815443E+03	2.815443E+03	2.815443E+03	2.815443E+03	2.815443E+03	1.1E+01		
	0.0	0.0	0.0	0.0	0.0	0.0	0.0	0.0		2.815443E+03	2.815443E+03	2.815443E+03	2.815443E+03	2.815443E+03	1.1E+01	
1031	0.0	0.0	-6.544667E+03	3.524448E+03	0.0	0.0	0.0	0.0	3.031574E+03	6.556023E+03	-3.513093E+03	-3.513093E+03	-3.513093E+03	-3.513093E+03	1.1E+01	
	0.0	0.0	2.096034E+03	-7.075117E+03	0.0	0.0	0.0	0.0		5.127604E+03	-6.043543E+03	-6.043543E+03	-6.043543E+03	-6.043543E+03	1.5E+01	
1032	0.0	0.0	-7.905314E+03	8.715129E+03	0.0	0.0	0.0	0.0	-1.521839E+03	7.193281E+03	-9.427153E+03	-9.427153E+03	-9.427153E+03	9.7E+00		
	0.0	0.0	9.413502E+02	-2.258788E+03	0.0	0.0	0.0	0.0		-5.804886E+02	-3.780586E+03	-3.780586E+03	-3.780586E+03	-3.780586E+03	5.8E+00	

CALC ONLY

ELEMENT ID.	SA1		SA2		SA3		SA4		AXIAL STRESS		SA-MIN		M.S.-T	
	SB1	SB2	SB2	SB2	SB3	SB3	SB4	SB4			SB-MIN	SB-MIN	M.S.-C	M.S.-C
1033	0.0	-2.115696E+03	5.074175E+03	0.0	0.0	5.446698E+02	5.618845E+03	-1.571026E+03	1.3E+01	1.690162E+03	-4.891615E+03	1.5E+01		
	0.8	1.145492E+03	-4.636285E+03	0.0	0.0									
1034	0.8	-1.405626E+03	2.458219E+03	9.311530E+02	2.667677E+03	2.667677E+03	5.125896E+03	1.182051E+03	1.1E+01	6.564999E+03	-1.393070E+03	4.5E+01		
	0.0	-4.060747E+03	3.897322E+03	1.694625E+03										
1035	0.8	-9.909220E+02	-1.539192E+03	2.987462E+03	-3.491066E+03	-3.491066E+03	-5.036034E+02	-5.030257E+03	1.2E+01	-2.285040E+03	-4.429747E+03	1.2E+01		
	0.0	-1.829194E+02	1.206025E+03	-9.386814E+02										
1036	0.8	2.278299E+02	-1.908489E+03	0.0	-1.052482E+03	-1.052482E+03	-0.246526E+02	-2.960972E+03	2.0E+01	-1.994928E+03	-3.047410E+03	2.0E+01		
	0.9	-1.994928E+03	-1.292666E+02	0.0										
1037	0.0	3.126321E+03	-4.493676E+01	0.0	1.390599E+03	1.390599E+03	4.516920E+03	1.345662E+03	1.6E+01	3.723160E+03	-1.735420E+03	3.6E+01		
	0.8	2.332562E+03	-3.126018E+03	0.0										
1038	0.0	2.224168E+02	-2.515387E+03	0.0	3.397620E+03	3.397620E+03	3.620237E+03	0.624337E+02	4.0E+00	1.196230E+04	3.113037E+02	4.0E+00		
	0.8	1.196230E+04	-3.086517E+03	0.0										
1039	0.0	-9.837960E+01	2.704251E+02	0.0	-3.972228E+02	-3.972228E+02	-1.267578E+02	-4.956024E+02	9.6E+01	7.944263E+02	-3.972228E+02	1.3E+02		
	0.8	1.191649E+03	7.166017E+02	0.0										
1041	0.0	1.555653E+04	-4.800976E+03	0.0	1.090777E+03	1.090777E+03	1.664731E+04	-3.710200E+03	3.6E+00	1.501013E+03	9.500049E+02	1.6E+01		
	0.0	-1.407717E+02	4.102364E+02	0.0										
1042	3.782699E+04	-3.702699E+04	0.0	0.0	-1.045006E+03	-1.045006E+03	3.598198E+04	-3.807199E+04	1.1E+00	1.700051E+04	-1.804551E+04	6.5E-01		
	-1.780051E+04	1.700051E+04	0.0	0.0										
1043	5.539652E+03	-5.539852E+03	0.0	0.0	3.952960E+03	3.952960E+03	9.492812E+03	-1.586892E+03	6.0E+00	1.057035E+04	-2.664431E+03	2.3E+01		
	-6.617391E+03	6.617391E+03	0.0	0.0										
1045	1.469270E+04	-1.469270E+04	0.0	0.0	-1.423981E+03	-1.423981E+03	1.326872E+04	-1.611668E+04	4.6E+00	5.258604E+03	-8.106566E+03	2.9E+00		
	-6.682585E+03	6.682585E+03	0.0	0.0										
1046	0.0	-2.206096E+01	-1.353416E+02	0.0	1.132696E+03	1.132696E+03	1.132696E+03	9.973546E+02	2.8E+01	2.62853E+03	6.567895E+02	2.8E+01		
	0.0	1.495857E+03	-4.759867E+02	0.0										
1048	1.109364E+04	-1.109364E+04	0.0	0.0	-7.511946E+02	-7.511946E+02	1.034245E+04	-1.164484E+04	6.2E+00	6.028137E+03	-7.530526E+03	4.3E+00		
	-6.779331E+03	6.779331E+03	0.0	0.0										
1049	-1.667271E+03	1.667271E+03	0.0	0.0	-6.038807E+02	-6.038807E+02	8.641900E+02	-2.470351E+03	2.0E+01	3.529428E+03	-5.135589E+03	1.1E+01		
	4.332509E+03	-4.332509E+03	0.0	0.0										
1050	0.0	0.0	0.0	0.0	3.177089E+03	3.177089E+03	3.177089E+03	3.177089E+03	9.7E+00	3.177089E+03	3.177089E+03	9.7E+00		
	0.0	0.0	0.0	0.0										
1051	0.0	-3.898966E+02	5.647023E+01	0.0	1.444876E+02	1.444876E+02	2.009578E+02	-2.454091E+02	5.0E+01	1.456901E+03	-5.818639E+03	1.0E+01		
	0.0	-5.963127E+03	1.312413E+03	0.0										

NADC-77149-30

CALC ONLY

ELEMENT ID.	STRESSES IN B A R E L E M E N T S				A X I A L S T R E S S		(C B A R)		M . S . - I	
	SA1 SB1	SA2 SB2	SA3 SB3	SA4 SB4	SA-MAX SB-MAX	SA-MIN SB-MIN	M . S . - I M . S . - C			
1052	0.0	-3.015926E+02	5.383697E+01	1.265174E+02	-1.055915E+03	-9.293975E+02	-1.357507E+03	4.3E+01		
	0.0	-1.611946E+03	2.773354E+03	-1.809399E+03		1.717439E+03	-2.865314E+03	2.2E+01		
1053	0.0	-1.048970E+03	1.819269E+03	0.0	-2.145029E+03	-3.257599E+02	-3.193899E+03	1.9E+01		
	0.0	-5.287154E+02	3.557652E+01	0.0		-2.109452E+03	-2.673744E+03			
1054	0.0	8.853433E+02	1.059482E+03	-1.588923E+03	-3.445218E+02	7.149602E+02	-1.933445E+03	1.0E+02		
	0.0	-4.746825E+02	9.337422E+01	1.904891E+02		-1.540327E+02	-8.192042E+02	3.3E+01		
1055	0.0	1.273418E+03	-5.457506E+02	0.0	1.293547E+03	2.566965E+03	7.477939E+02	2.0E+01		
	0.0	-3.749742E+03	2.235282E+03	0.0		3.528828E+03	-2.456196E+03	2.5E+01		
1056	0.0	4.420006E+02	4.458882E+02	-1.485616E+03	5.711855E+02	1.017074E+03	-9.144304E+02	5.5E+01		
	0.0	-1.909231E+02	7.692070E+02	-1.094708E+03		1.340392E+03	-5.235222E+02	7.0E+01		
1057	0.0	4.716131E+02	-5.150583E+02	0.0	-1.467445E+03	-9.958321E+02	-1.982503E+03	1.3E+01		
	0.0	-3.104135E+03	9.48037E+02	0.0		-5.186415E+02	-4.571580E+03			
1058	0.0	-8.099422E+02	-4.331376E+03	4.850423E+03	-4.887271E+02	4.361696E+03	-4.820103E+03	1.6E+01		
	0.0	3.775117E+02	-1.006521E+02	-1.412744E+02		-1.112154E+02	-6.300015E+02	1.2E+01		
1059	0.0	3.714040E+01	-2.410309E+03	0.0	2.950386E+02	3.321790E+02	-2.115270E+03	2.9E+01		
	0.0	1.831230E+03	2.172413E+03	0.0		2.467451E+03	2.950366E+02	3.0E+01		
1060	0.0	4.998009E+02	-6.623520E+02	0.0	9.882456E+02	1.488047E+03	2.458936E+02	4.8E+01		
	0.0	-8.556299E+02	6.176234E+02	0.0		1.525869E+03	5.261577E+01			
1061	0.0	1.536676E+02	-1.065726E+03	0.0	-8.569104E+02	-7.832429E+02	-1.922637E+03	3.3E+01		
	0.0	1.524571E+02	-6.326452E+02	0.0		-7.044533E+02	-1.489555E+03			
1062	0.0	6.983024E+01	-3.806366E+02	0.0	-7.465006E+02	-6.766703E+02	-1.127137E+03	4.4E+01		
	0.0	2.401231E+03	-4.924733E+02	0.0		1.654731E+03	-1.238974E+03	5.1E+01		
1063	0.0	1.182905E+03	-2.59882E+03	2.253857E+03	1.275977E+03	3.529834E+03	-1.323005E+03	2.0E+01		
	0.0	-8.534337E+02	-1.018195E+03	1.267193E+03		2.543170E+03	2.577820E+02	4.8E+01		
1064	0.0	7.244055E+01	1.903349E+02	-3.724938E+02	1.736213E+03	1.926548E+03	1.363719E+03	2.5E+01		
	0.0	-4.788260E+02	1.135160E+03	-1.148320E+03		2.871373E+03	5.878935E+02			
1065	0.0	1.006021E+03	-1.401148E+03	1.107631E+03	7.302623E+02	1.837893E+03	-6.708855E+02	2.4E+01		
	0.0	1.020706E+03	-2.571163E+03	2.273361E+03		3.003623E+03	-1.840900E+03	3.4E+01		
1066	0.0	-1.664749E+03	6.979174E+02	0.0	-2.632820E+02	4.346355E+02	-1.928031E+03	1.7E+02		
	0.0	-2.669575E+03	5.616799E+02	0.0		2.983979E+02	-2.932661E+03	2.1E+01		
1067	0.0	-7.031101E+02	1.237567E+03	-1.038545E+03	1.644914E+03	2.882482E+03	6.063697E+02	2.5E+01		
	0.0	1.170031E+02	-2.536994E+02	2.448704E+02		1.809785E+03	1.391215E+03			

NADC-77149-30

CALC ONLY

ELEMENT ID.	SA1		SA2		SA3		SA4		AXIAL STRESS		SA-MIN		SA-MAX		M.S.-T		
	0.0	0.0	0.0	0.0	0.0	0.0	0.0	0.0	0.0	0.0	0.0	0.0	0.0	0.0	0.0	0.0	
1068	0.0	0.0	-8.954345E+01	6.964503E+02	8.77239E+01	7.636696E+02	-3.526523E+01	-1.172053E+03	7.053620E+02	8.731344E+02	1.549032E+03	6.958185E+02	-3.066972E+02	4.7E+01	1.7E+02		
1069	0.0	0.0	4.525977E+02	-8.861499E+02	1.303166E+03	-1.019799E+03	0.0	0.0	1.428524E+02	1.428524E+02	1.428524E+02	1.428524E+02	-8.769461E+02	5.1E+01	7.3E+01		
1070	0.0	0.0	-4.323784E+02	3.979423E+02	1.219394E+02	-6.541976E+02	3.254993E+02	5.100412E+02	4.329083E+02	7.584076E+02	9.509495E+02	5.299255E-01	-2.212893E+02	7.8E+01	2.9E+02		
1071	0.0	0.0	-5.038287E+02	1.728042E+02	-5.614628E+02	1.667354E+02	8.569016E+02	-2.689656E+02	1.339399E+02	9.908415E+02	3.067441E+02	-4.275229E+02	-1.341257E+02	7.5E+01	1.5E+02		
1072	0.0	0.0	1.336373E+02	4.780258E+02	1.123068E+03	-1.198426E+03	0.0	0.0	3.127109E+02	1.435779E+03	7.907367E+02	3.127109E+02	-8.057147E+02	5.1E+01	7.2E+01		
1073	0.0	0.0	-5.406718E+02	7.123509E+02	-8.064023E+02	-1.65373E+02	1.669930E+03	-4.975907E+02	-3.554787E+02	1.314451E+03	3.568723E+02	-1.161881E+03	-8.530693E+02	5.6E+01	5.5E+01		
1074	0.0	0.0	-5.225133E+02	-2.558669E+02	4.591637E+02	-1.299786E+03	-1.447070E+02	1.451871E+03	0.213312E+01	5.412969E+02	1.534004E+03	-4.403801E+02	-1.217652E+03	4.8E+01	5.2E+01		
1075	0.0	0.0	-2.145605E+03	-6.656756E+03	1.505951E+02	4.673293E+02	0.0	0.0	1.425583E+02	3.331533E+02	6.498876E+02	-1.963047E+03	-6.474198E+03	1.1E+02	9.0E+00		
1076	0.0	0.0	2.357626E+02	-4.042547E+03	-1.107713E+03	2.568827E+03	0.0	0.0	-1.354121E+03	-1.118359E+03	1.214706E+03	-2.461834E+03	-5.396668E+03	6.1E+01	1.1E+01		
1077	0.0	0.0	4.420049E+03	-3.761894E+02	-2.397507E+03	2.040513E+02	-2.397507E+03	2.040513E+02	-5.323710E+02	3.687678E+03	-3.283197E+02	-2.929878E+03	-9.085605E+02	1.9E+01	2.1E+01		
1078	0.0	0.0	3.923650E+03	-1.206514E+04	-2.128252E+03	6.544329E+03	-2.128252E+03	6.544329E+03	-3.169878E+03	7.537715E+02	3.374451E+03	-5.298130E+03	-1.523501E+04	2.2E+01	3.2E+00		
1079	0.0	0.0	-1.072118E+04	2.400555E+03	5.815345E+03	-1.302100E+03	5.815345E+03	-1.302100E+03	-2.724801E+03	3.090544E+03	-3.242459E+02	-1.344598E+04	-4.026901E+03	2.4E+01	3.8E+00		
1080	0.0	0.0	2.356009E+03	1.645063E+03	-1.27938E+03	-8.923092E+02	-1.27938E+03	-8.923092E+02	-1.148728E+03	1.207281E+03	4.963347E+02	-2.426666E+03	-2.041038E+03	6.3E+01	2.5E+01		
1081	0.0	0.0	2.633125E+03	3.710752E+02	-1.536734E+03	-2.012773E+02	-1.536734E+03	-2.012773E+02	-1.081825E+03	1.751300E+03	-7.107494E+02	-2.618558E+03	-1.283102E+03	4.3E+01	2.3E+01		
1082	-4.006527E+03	-3.758396E+03	4.086627E+03	8.758396E+03	0.0	0.0	0.0	0.0	1.592467E+04	1.993130E+04	2.468307E+04	1.191804E+04	7.166273E+03	2.0E+00			
1083	-1.160162E+04	-3.738261E+03	1.160162E+04	3.738261E+03	0.0	0.0	0.0	0.0	1.448967E+04	2.609129E+04	1.822793E+04	2.888048E+03	1.075141E+04	1.8E+00			

NADC-77149-30

CALC ONLY

ELEMENT ID.	SA1		SA2		SA3		SA4		SA MAX		SA-MIN		M.S.-T	
	SB1	SB2	SB3	SB4	SB3	SB4	SB4	SB4	SB-MAX	SB-MIN	SB-MIN	SB-MIN	M.S.-C	M.S.-C
1084	-2.251609E+04	2.251609E+04	0.0	0.0	0.0	0.0	0.0	0.0	3.326766E+04	-1.176451E+04	-1.176451E+04	1.2E+00	1.2E+00	4.4E+00
1085	3.302405E+03	-3.302405E+03	0.0	0.0	0.0	0.0	0.0	0.0	6.957270E+03	3.524598E+02	3.524598E+02	8.8E+00	8.8E+00	3.0E+02
1086	0.0	0.0	0.0	0.0	0.0	0.0	0.0	0.0	1.325099E+03	1.325099E+03	1.325099E+03	2.5E+01	2.5E+01	1.7E+01
1087	0.0	0.0	0.0	0.0	0.0	0.0	0.0	0.0	-3.103808E+03	-3.103808E+03	-3.103808E+03	6.4E+00	6.4E+00	6.4E+00
1088	0.0	0.0	0.0	0.0	0.0	0.0	0.0	0.0	-1.250942E+03	-1.250942E+03	-1.250942E+03	1.7E+01	1.7E+01	1.7E+01
1090	0.0	0.0	0.0	0.0	0.0	0.0	0.0	0.0	-4.720228E+03	-4.720228E+03	-4.720228E+03	3.9E+00	3.9E+00	3.9E+00
1091	0.0	0.0	0.0	0.0	0.0	0.0	0.0	0.0	2.588185E+03	2.588185E+03	2.588185E+03	1.2E+01	1.2E+01	1.2E+01
1093	0.0	0.0	0.0	0.0	0.0	0.0	0.0	0.0	7.246874E+03	7.246874E+03	7.246874E+03	3.7E+00	3.7E+00	3.7E+00
1094	1.746692E+04	-1.746692E+04	0.0	0.0	0.0	0.0	0.0	0.0	2.366423E+04	-1.130761E+04	-1.130761E+04	2.1E+00	2.1E+00	4.6E+00
1095	-3.847319E+02	3.847319E+02	0.0	0.0	0.0	0.0	0.0	0.0	1.597111E+03	8.276475E+02	8.276475E+02	4.5E+01	4.5E+01	4.5E+01
1096	-9.290508E+00	9.290508E+00	-9.155863E+00	9.155863E+00	-9.155863E+00	9.155863E+00	-9.155863E+00	9.155863E+00	8.444768E+00	-1.013625E+01	-1.013625E+01	4.5E+01	4.5E+01	4.5E+01
1097	-6.345449E-01	6.345449E-01	-6.345449E-01	6.345449E-01	-6.345449E-01	6.345449E-01	-6.345449E-01	6.345449E-01	-1.570594E+02	-1.583285E+02	-1.583285E+02	4.5E+01	4.5E+01	4.5E+01
1099	-4.526506E+02	4.526506E+02	-4.699273E+02	4.699273E+02	-4.699273E+02	4.699273E+02	-4.699273E+02	4.699273E+02	3.495271E+02	-5.903275E+02	-5.903275E+02	4.5E+01	4.5E+01	4.5E+01
1101	-5.199099E+02	5.199099E+02	-6.199099E+02	6.199099E+02	-6.199099E+02	6.199099E+02	-6.199099E+02	6.199099E+02	5.171464E+02	-7.226713E+02	-7.226713E+02	4.5E+01	4.5E+01	4.5E+01
1103	-4.085269E+02	4.085269E+02	-3.993808E+02	3.993808E+02	-3.993808E+02	3.993808E+02	-3.993808E+02	3.993808E+02	2.53244E+02	-5.638292E+02	-5.638292E+02	4.5E+01	4.5E+01	4.5E+01
1104	5.836581E+02	-5.836581E+02	5.836581E+02	-5.836581E+02	5.836581E+02	-5.836581E+02	5.836581E+02	-5.836581E+02	6.058344E+02	-5.617818E+02	-5.617818E+02	4.5E+01	4.5E+01	4.5E+01

NADC-77149-30

FREE FLIGHT-55

CALC ONLY

ELEMENT ID.	STRESSES IN BAR ELEMENTS (C B A R)				AXIAL STRESS		SA-MIN SB-MIN		M.S.-T M.S.-C	
	SA1 SB1	SA2 SB2	SA3 SB3	SA4 SB4	SA-MAX SB-MAX	SA-MIN SB-MIN	SA-MIN SB-MIN	M.S.-T M.S.-C		
1105	5.509165E+03 7.958946E+02	-5.509165E+03 -7.960946E+02	0.0 0.0	0.0 0.0	-2.174784E+03 -1.377889E+03	3.334381E+03 -2.971679E+03	-7.683949E+03 -2.971679E+03	2.1E+01 7.2E+00		
1106	-9.461033E+03 2.047019E+04	9.461033E+03 -2.047019E+04	0.0 0.0	0.0 0.0	-4.118057E+02	9.049227E+03 2.005839E+04	-9.872839E+03 -2.088200E+04	2.7E+00 2.0E+00		
1107	5.848264E+03 9.352561E+03	-5.848264E+03 -9.352561E+03	0.0 0.0	0.0 0.0	-7.028160E+02	5.146248E+03 8.658545E+03	-6.550280E+03 -1.005458E+04	7.6E+00 5.3E+00		
1108	-1.734078E+04 6.334868E+03	1.734078E+04 -6.334868E+03	0.0 0.0	0.0 0.0	8.628755E+02	1.820366E+04 7.197743E+03	-1.647791E+04 -5.471992E+03	3.1E+00 2.8E+00		
1109	0.0 0.0	-1.443644E+02 -7.124799E+02	-5.579537E+02 3.679174E+01	0.0 0.0	2.203174E+02	2.203174E+02 2.571091E+02	-3.376363E+02 -4.921625E+02	2.9E+02 1.3E+02		
1110	-1.518029E+01 3.565416E+00	1.518029E+01 -3.565416E+00	-1.496343E+01 3.515467E+00	1.496343E+01 -3.515467E+00	8.322030E-01	1.601250E+01 4.398625E+00	-1.434408E+01 -2.734207E+00	4.6E+00		
1114	3.152177E+02 2.807361E+02	-3.152177E+02 -2.807361E+02	3.105822E+02 2.766076E+02	-3.105822E+02 -2.766076E+02	3.478616E+01	3.500039E+02 3.152233E+02	-2.804316E+02 -2.459499E+02	7.6E+00 1.4E+01		
1115	2.118973E+02 -5.023938E+03	1.971567E+03 4.889064E+03	0.0 0.0	0.0 0.0	8.427078E+03	1.039864E+04 1.331614E+04	8.427078E+03 3.403140E+03	4.6E+00		
1115	6.576910E+03 2.597980E+03	-6.320510E+03 3.639794E+01	0.0 0.0	0.0 0.0	2.026291E+03	8.603200E+03 4.534271E+03	-4.294219E+03 2.026291E+03	7.6E+00 1.4E+01		
1117	-1.123573E+03 -2.233369E+02	1.055777E+03 3.395189E+02	0.0 0.0	0.0 0.0	6.787093E+02	1.734486E+03 1.019228E+03	-4.448633E+02 4.553724E+02	4.2E+01 1.4E+02		
1118	3.236243E+03 -9.048020E+02	-1.097199E+03 8.714585E+02	0.0 0.0	0.0 0.0	-1.777416E+02	3.058501E+03 6.937169E+02	-1.274940E+03 -1.082544E+03	2.3E+01 4.8E+01		
1119	-3.224718E+03 3.930256E+03	2.283124E+03 -3.720235E+03	0.0 0.0	0.0 0.0	-2.284210E+03	7.891402E+01 1.726047E+03	-5.428928E+03 -5.924445E+03	4.2E+01 9.6E+00		
1120	-9.574585E+03 -2.768458E+03	9.503353E+03 1.915566E+03	0.0 0.0	0.0 0.0	-1.745269E+03	7.758084E+03 1.702963E+02	-1.131935E+04 -4.533727E+03	8.5E+00 4.6E+00		
1121	3.354432E+03 -1.194316E+04	-2.468528E+03 3.279839E+03	-4.006251E+03 1.960323E+04	0.0 0.0	-1.171417E+03	2.183015E+03 1.843181E+04	-5.17669E+03 -1.311457E+04	3.2E+00 4.3E+00		
1122	-2.179312E+03 2.199038E+02	5.006266E+03 1.495702E+03	-6.948521E+02 -1.869075E+03	0.0 0.0	-7.912187E+03	-2.905921E+03 -6.416486E+03	-1.009150E+04 -9.781263E+03	5.8E+00		
1123	-3.000774E+03 -1.291592E+03	2.524793E+02 7.855563E+03	5.479381E+03 -5.149493E+03	0.0 0.0	3.373394E+03	8.852776E+03 1.122896E+04	3.726205E+02 -1.776099E+03	5.9E+00 3.8E+01		

NADC-77149-30

CALC ONLY

ELEMENT ID.	STRESSES IN B A R R E L E M E N T S (C B A R)				AXIAL STRESS		SA-MIN SB-MIN		M.S.-T M.S.-C	
	SA1 SBI	SA2 SBI	SA3 SBI	SA4 SBI	SA-MAX SB-MAX	SA-MIN SB-MIN	M.S.-T M.S.-C	M.S.-T M.S.-C		
1124	6.20895E+03 -2.654982E+03	-3.470228E+03 3.318550E+03	-8.480411E+03 1.655850E+03	0.0 0.0	1.074032E+04 1.405097E+04	1.694922E+04 2.259914E+03	2.259914E+03 8.085342E+03	3.6E+00	3.6E+00	
1125	0.0 0.0	3.226296E+02 3.545181E+02	-3.615843E+03 1.499525E+03	3.408968E+03 -1.686816E+03	1.410820E+02 1.600707E+03	3.550042E+03 -3.474761E+03	-3.474761E+03 -1.545734E+03	2.0E+01 1.8E+01	2.0E+01 1.8E+01	
1126	0.0 0.0	-7.170323E+03 5.886998E+02	6.975212E+03 -5.726808E+02	0.0 0.0	-1.916465E+02 -3.972541E+02	6.783566E+03 3.970534E+02	-7.361969E+03 -7.643273E+02	1.0E+01 8.4E+00	1.0E+01 8.4E+00	
1127	0.0 0.0	-6.010374E+00 1.331648E+03	5.856826E+00 -1.295412E+03	0.0 0.0	-3.972541E+02 -1.398763E+03	-3.914072E+02 -9.022354E+02	-4.032644E+02 -1.881779E+03	8.2E+01 3.6E+01	8.2E+01 3.6E+01	
1128	0.0 0.0	4.965274E+02 3.407670E+00	-4.830164E+02 -8.178889E+00	0.0 0.0	-1.398763E+03 -2.252942E+03	-9.022354E+02 -1.452260E+03	-1.881779E+03 -3.076021E+03	3.6E+01 2.1E+01	3.6E+01 2.1E+01	
1129	0.0 0.0	-8.230787E+02 -8.891856E+02	8.006820E+02 8.649901E+02	0.0 0.0	-2.252942E+03 -3.507879E+03	-1.452260E+03 -2.281732E+03	-3.076021E+03 -4.768324E+03	2.1E+01 1.3E+01	2.1E+01 1.3E+01	
1130	0.0 0.0	-1.260445E+03 1.275435E+02	1.226147E+03 -1.240729E+02	0.0 0.0	-3.507879E+03 -5.519335E+01	-2.281732E+03 1.500417E+01	-4.768324E+03 -1.253909E+02	1.3E+01 3.3E+00	1.3E+01 3.3E+00	
1136	-7.013751E+01 -8.809030E+01	7.019751E+01 8.809030E+01	-7.019751E+01 8.809030E+01	7.019751E+01 8.809030E+01	-5.519335E+01 -1.536675E+04	1.500417E+01 3.289695E+01	-1.253909E+02 -1.432836E+02	3.3E+00 1.6E-02	3.3E+00 1.6E-02	
1139	-1.459710E+03 3.262303E+04	-1.465353E+03 4.113786E+03	4.53462E+03 -4.664369E+04	0.0 0.0	-1.536675E+04 3.832040E+03	-1.083229E+04 3.028523E+04	-1.683647E+04 -1.441867E+04	3.3E+00 1.4E+00	3.3E+00 1.4E+00	
1140	-1.772879E+03 4.098513E+03	2.645319E+04 9.370297E+02	-1.825071E+04 -2.908120E+03	9.975360E+03 -6.069603E+03	3.832040E+03 -1.051804E+03	7.930553E+03 2.621577E+03	-2.237563E+03 -6.570553E+03	3.4E+00 8.6E+00	3.4E+00 8.6E+00	
1141	3.673381E+03 -1.087590E+03	5.521086E+02 -6.337194E+02	-2.397477E+03 1.051403E+03	-5.518749E+03 1.505282E+03	-1.051804E+03 -3.939356E+03	4.534773E+02 -2.466993E+03	-2.139403E+03 -4.994458E+03	2.7E+01 8.9E+00	2.7E+01 8.9E+00	
1142	-1.055112E+03 1.675925E+03	-5.707782E+02 5.927243E+02	9.880292E+02 -1.341377E+03	1.472363E+03 -2.424578E+03	-3.939356E+03 -4.442465E+03	-2.466993E+03 -2.263431E+03	-4.994458E+03 -6.363934E+03	8.9E+00 6.3E+00	8.9E+00 6.3E+00	
1143	1.658821E+03 -4.089809E+02	8.208151E+02 -1.527268E+03	-1.502688E+03 1.331608E+03	-2.351414E+03 2.133208E+02	-4.442465E+03 -5.054540E+03	-2.773644E+03 -3.110858E+03	-6.793679E+03 -5.969733E+03	6.3E+00 2.4E+01	6.3E+00 2.4E+01	
1144	3.956317E+02 8.033576E+03	1.437323E+03 7.249167E+03	-1.259021E+03 -9.831612E+03	-2.173297E+02 -1.041602E+04	-5.054540E+03 -1.257320E+03	-3.617225E+03 2.979028E+03	-6.313569E+03 -1.547057E+04	2.4E+01 3.1E+00	2.4E+01 3.1E+00	
1145	8.0 0.0	6.982476E+02 1.905994E+03	-3.787410E+02 -1.033842E+03	-3.787410E+02 -1.033842E+03	-1.257320E+03 -1.267855E+03	-5.590722E+02 6.486737E+02	-1.636061E+03 -2.291162E+03	1.2E+02 2.7E+01	1.2E+02 2.7E+01	
1146	3.568452E+03 -3.788218E+03	5.322128E+03 -3.669339E+03	-5.322128E+03 3.669339E+03	0.0 0.0	-1.267855E+03 2.401484E+03	4.054274E+03 -6.589903E+03	-6.589903E+03 -9.056073E+03	1.7E+01 8.6E+00	1.7E+01 8.6E+00	

CALC ONLY

ELEMENT ID.	SA1		SA2		SA3		SA4		AXIAL STRESS		SA-MAX		SA-MIN		M.S.-T	
	SB1	SB2	SB2	SB2	SB3	SB3	SB4	SB4			SB-MAX	SB-MAX	SB-MIN	SB-MIN	M.S.-C	M.S.-C
1147	6.548716E+02	-1.387828E+03	1.018588E+03	-1.205970E+03	1.018588E+03	-1.387828E+03	-1.205970E+03	1.018588E+03	3.047912E+02	1.323379E+03	-1.083037E+03	3.314536E+03	-1.694245E+03	1.083037E+03	2.1E+01	3.6E+01
	-1.999036E+03	3.007974E+03	-1.995494E+03	3.009745E+03	-1.995494E+03	3.007974E+03	3.009745E+03	-1.995494E+03	9.094505E+02	2.336926E+03	-1.190271E+03	2.216733E+03	-9.918684E+02	1.190271E+03	3.1E+01	5.2E+01
1148	1.347475E+03	-2.144023E+03	1.203828E+03	-2.179721E+03	1.203828E+03	-2.144023E+03	-2.179721E+03	1.203828E+03	1.736124E+03	2.936015E+03	1.379706E+02	2.478952E+03	5.544102E+02	1.379706E+02	2.4E+01	
	1.017066E+03	-1.981319E+03	1.227283E+03	-1.051859E+03	1.227283E+03	-1.981319E+03	-1.051859E+03	1.227283E+03	8.469083E+02	1.032735E+04	-9.553603E+03	2.682560E+04	-2.471750E+04	9.553603E+03	1.8E+00	9.2E-02
1149	1.199991E+03	-1.306051E+03	5.432753E+02	-1.598153E+03	5.432753E+02	-1.306051E+03	-1.598153E+03	5.432753E+02	-1.119167E+03	2.484117E+04	-2.664386E+04	7.103692E+03	-9.192492E+03	2.664386E+04	2.0E+00	1.3E-02
	7.423280E+02	-1.146963E+03	6.329348E+02	-1.181714E+03	6.329348E+02	-1.146963E+03	-1.181714E+03	6.329348E+02	-5.101382E+03	2.743510E+03	-1.278660E+04	6.946879E+03	-1.738865E+04	1.278660E+04	9.8E+00	5.5E-01
1152	-1.040051E+04	9.480443E+03	4.600341E+02	0.0	4.600341E+02	0.0	0.0	0.0	-6.611523E+03	5.347420E+03	-1.877266E+04	-1.634862E+03	-1.199995E+04	1.877266E+04	1.3E+01	4.4E-01
	2.597869E+04	2.515029E+04	-2.556449E+04	0.0	-2.556449E+04	0.0	0.0	0.0	-4.031776E+03	6.477893E+02	-9.879884E+03	9.364926E+03	-1.924700E+04	9.879884E+03	7.0E+00	4.0E-01
1153	2.596054E+04	2.508904E+04	-2.552469E+04	0.0	-2.552469E+04	0.0	0.0	0.0								
	7.923792E+03	8.22859E+03	-8.07325E+03	0.0	-8.07325E+03	0.0	0.0	0.0								
1154	7.524431E+03	7.844892E+03	-7.684646E+03	0.0	-7.684646E+03	0.0	0.0	0.0								
	-1.180925E+04	-1.228727E+04	1.204826E+04	0.0	1.204826E+04	0.0	0.0	0.0								
1155	-1.175675E+04	-1.216113E+04	1.195894E+04	0.0	1.195894E+04	0.0	0.0	0.0								
	-5.388430E+03	-4.564890E+03	4.976660E+03	0.0	4.976660E+03	0.0	0.0	0.0								
1156	5.479566E+03	4.616650E+03	-5.048108E+03	0.0	-5.048108E+03	0.0	0.0	0.0								
	-1.397818E+04	-1.441522E+04	1.419670E+04	0.0	1.419670E+04	0.0	0.0	0.0								

NADC-77149-30

UNLESS OTHERWISE SPECIFIED DIMENSIONS ARE IN INCHES TOLERANCES ARE: FRACTIONS DECIMALS ± .005 ± .0001 ± .001 ± .002	CONTRACT NO.	NAVAL AIR DEVEL WARMINGTON,	
	DO NOT SCALE FROM DRAWING	DATE	RIGHT SKIN PA
DRAWN	CHECKED	P. RICHY	8/21/51
		<i>Wilson</i>	<i>Smith</i>
APPROVED	NO.	CORE SHEET NO.	DATE
		80206	667A
	SCALE	FULL	BY

NOTES

1. MATERIALS
 GRAPHITE - HERCULES 3501 AS
 GLASS - CORLOPREG E293
 ADHESIVE - METABOND 329
2. MB 329 SHALL BE USED TO BOND CORE TO FACES
3. SOFTENING STRIPS
 GLASS REPLACES GRAPHITE IN THESE AREAS
 SOFTENING STRIP RUNS ENTIRE LENGTH OF PLYS 2,4,14,16
4. CURE TEMPERATURE - 350°
5. CORE FILL -
6. TOLERANCES = ± OR AS NOTED

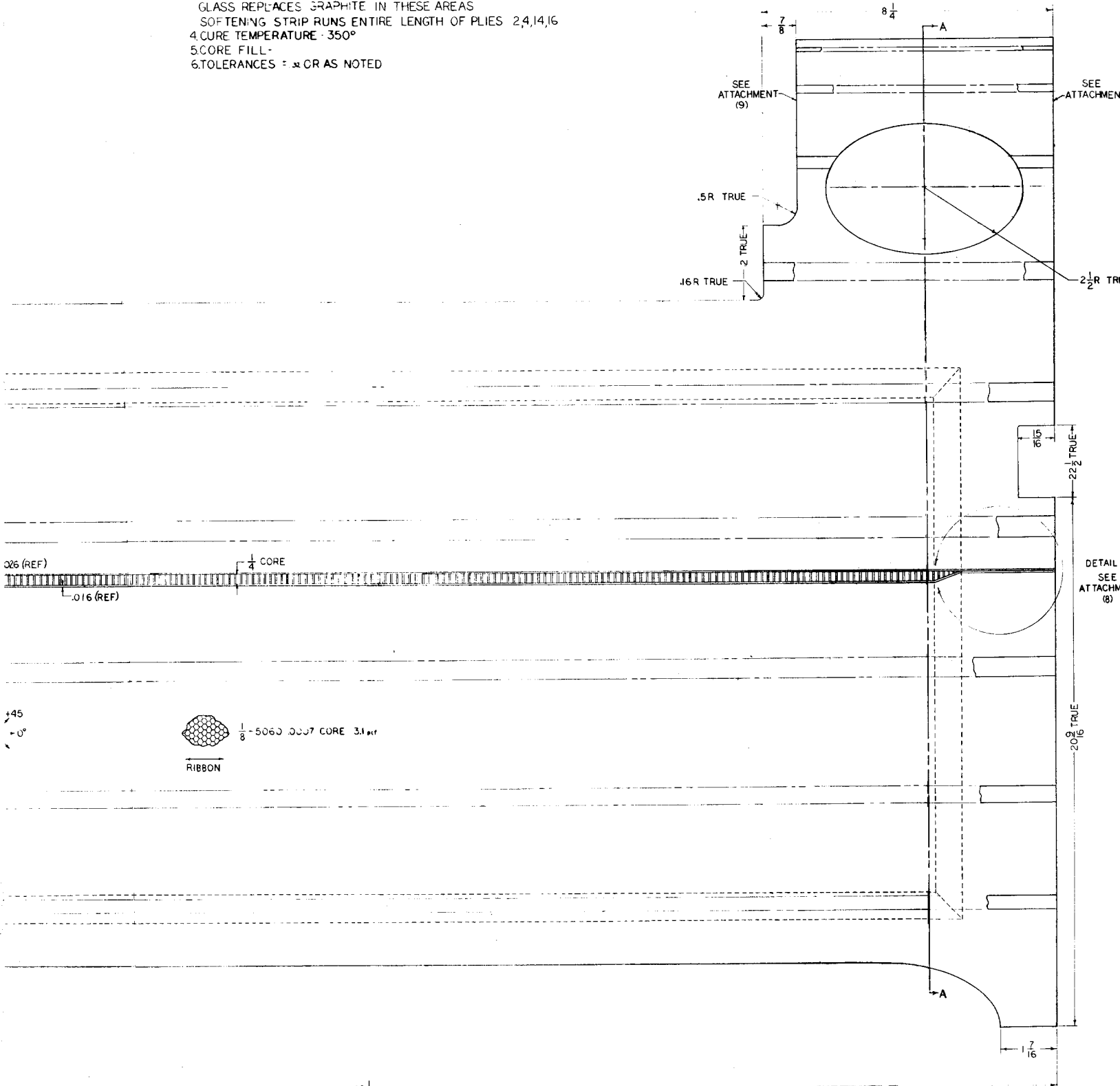

UNLESS OTHERWISE SPECIFIED DIMENSIONS ARE IN INCHES FRACTIONS SHALL BE IN 16ths DECIMALS SHALL BE TO 2 PLACES UNLESS OTHERWISE SPECIFIED	CONTRACT NO.		NAVAL AIR DEVELOPMENT CENTER WARRINGTON, PA 16974	
	DRAWN BY R. RICHY	CHECKED BY <i>[Signature]</i>	RIGHT SKIN PANEL	
MATERIAL:	APPROVED:	PART CODE UNIT NO. 80206	DRAWING NO. 667 A107	SHEET 1 OF 4
NAME FULL		WT.	UNIT / OF	

PLYS 3501 AS
 G E293
 DND 329
 USEL TO BOND CORE TO FACES
 S
 GRAPHITE IN THESE AREAS
 RUNS ENTIRE LENGTH OF PLYS 2,4,14,16
 E 350°
 OR AS NOTED

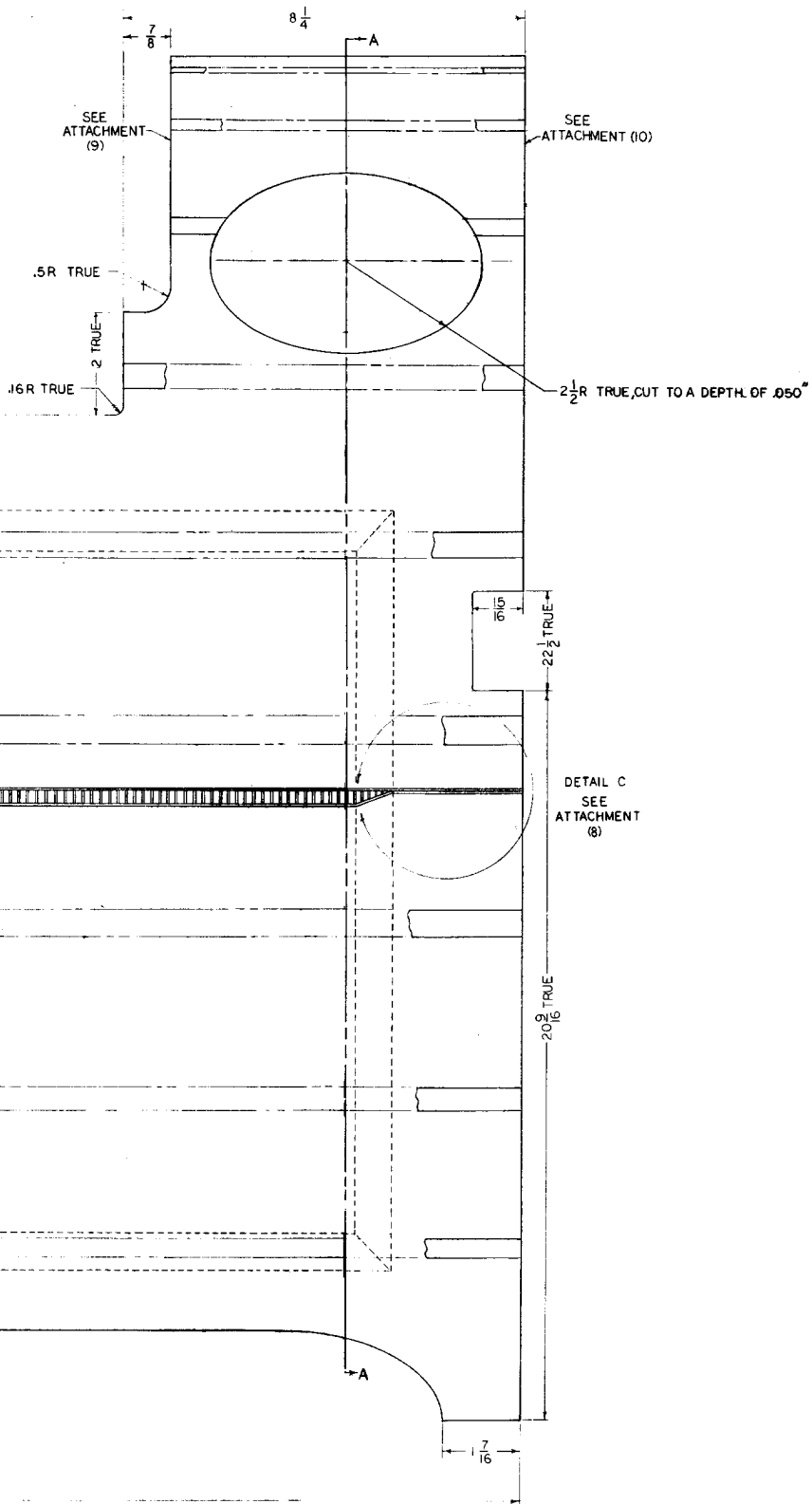

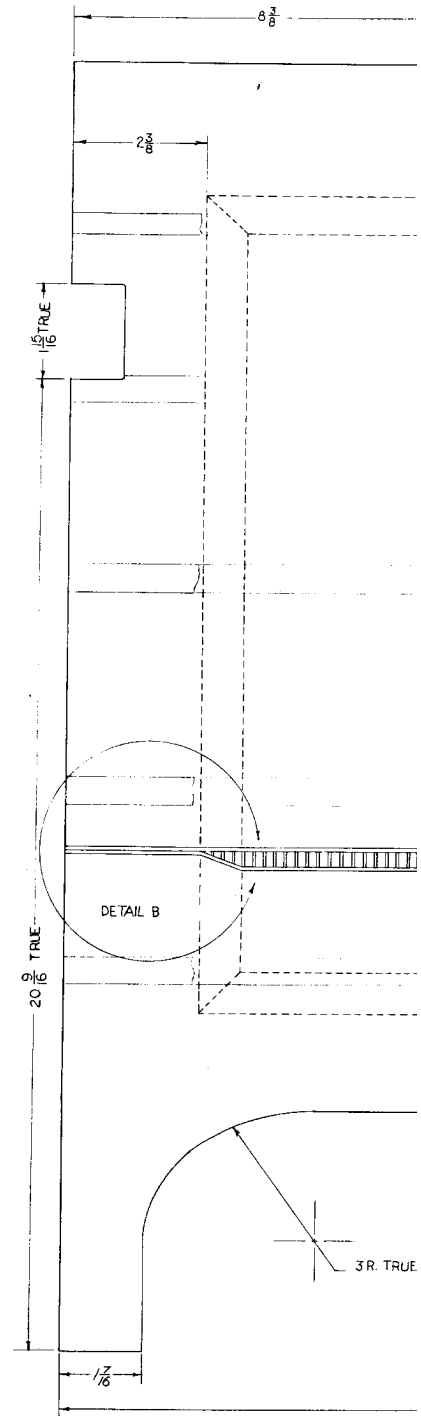
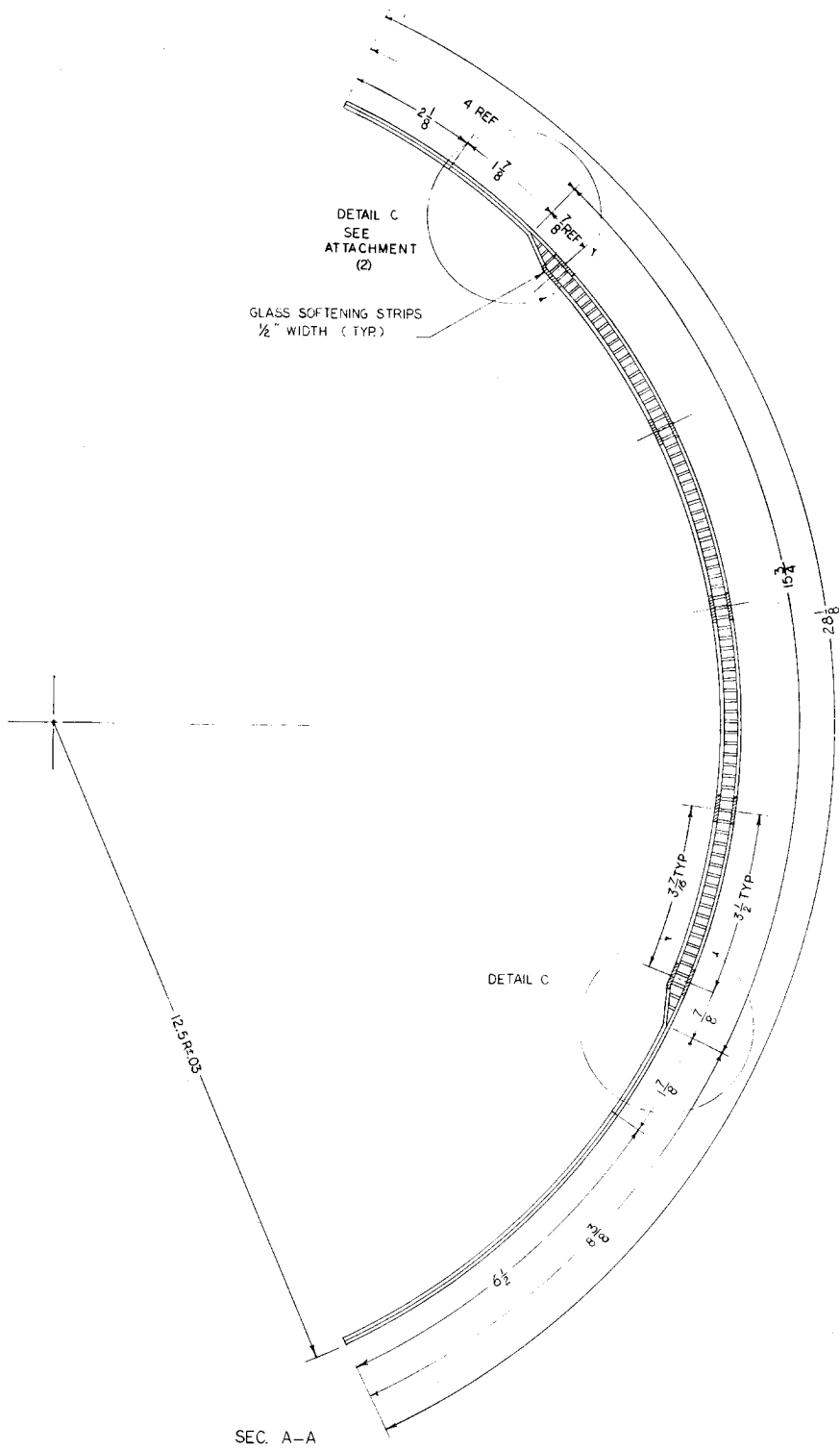

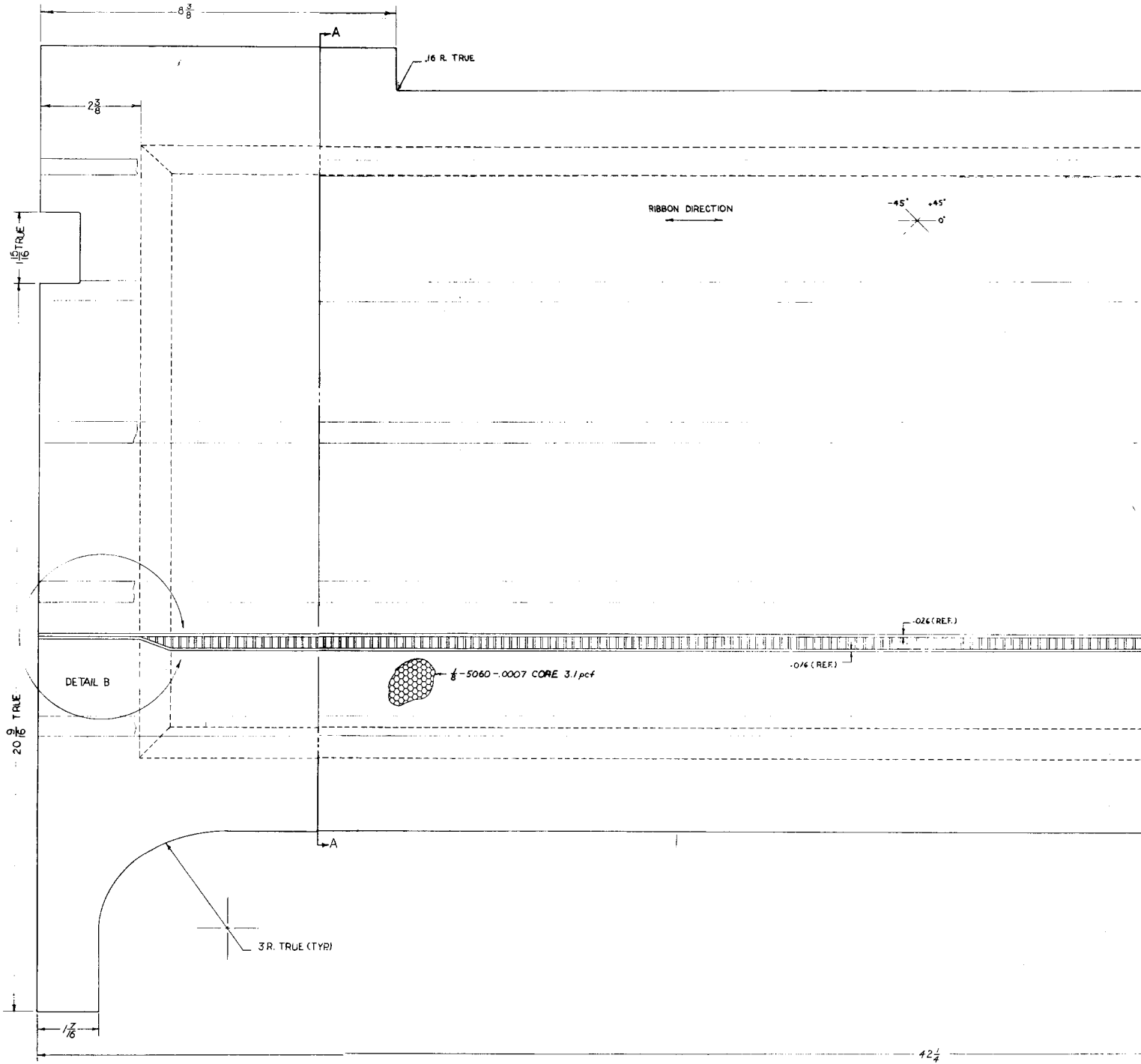
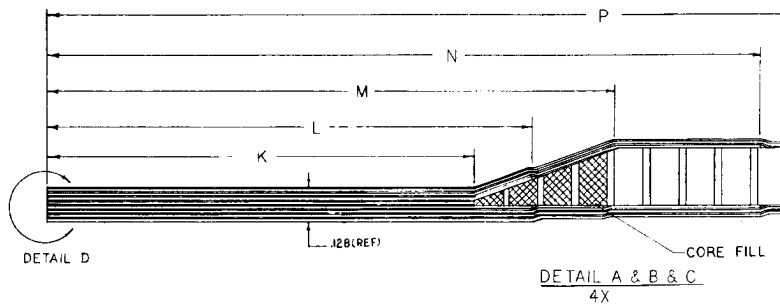

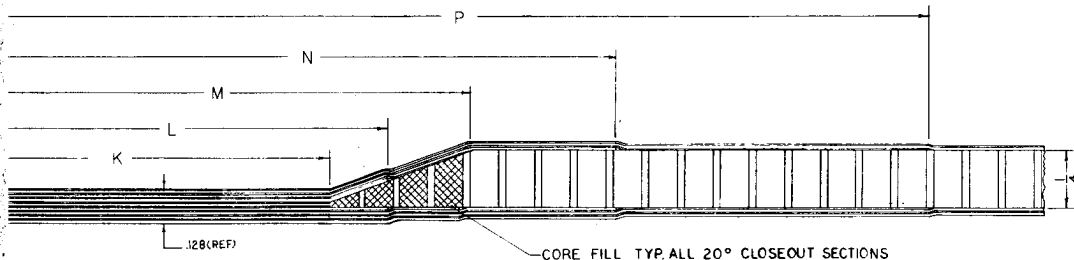

CORE FILL TYP. ALL 20° CLOSEOUT SECTIONS
 DETAIL A & B & C
 4X

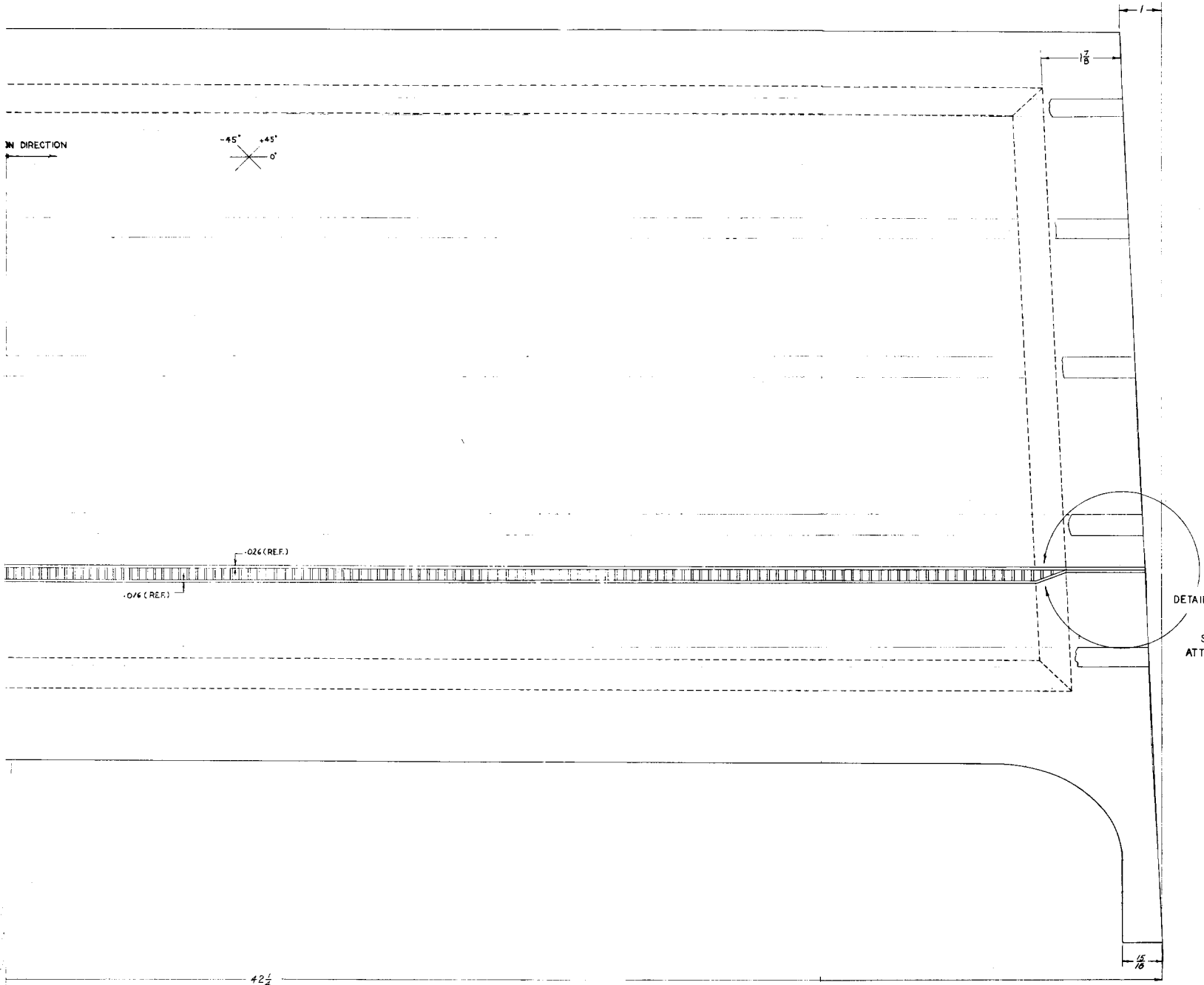

DETAIL
 ATT

42 1/4

UNLESS OTHERWISE SPECIFIED
 DIMENSIONS ARE IN INCHES
 TOLERANCES ARE AS SHOWN
 FINISHES ARE AS SHOWN
 ALL DIMENSIONS TO FACE UNLESS NOTED OTHERWISE
 DO NOT SCALE THIS DRAWING
 DATE:

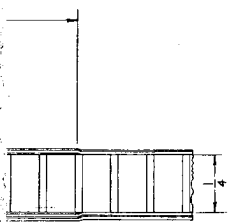

ONS

DETAIL D

PLY NO.



KEY
 G - GRAPHITE EPOXY 0'
 W - WOVEN GLASS ±.45'
 REF

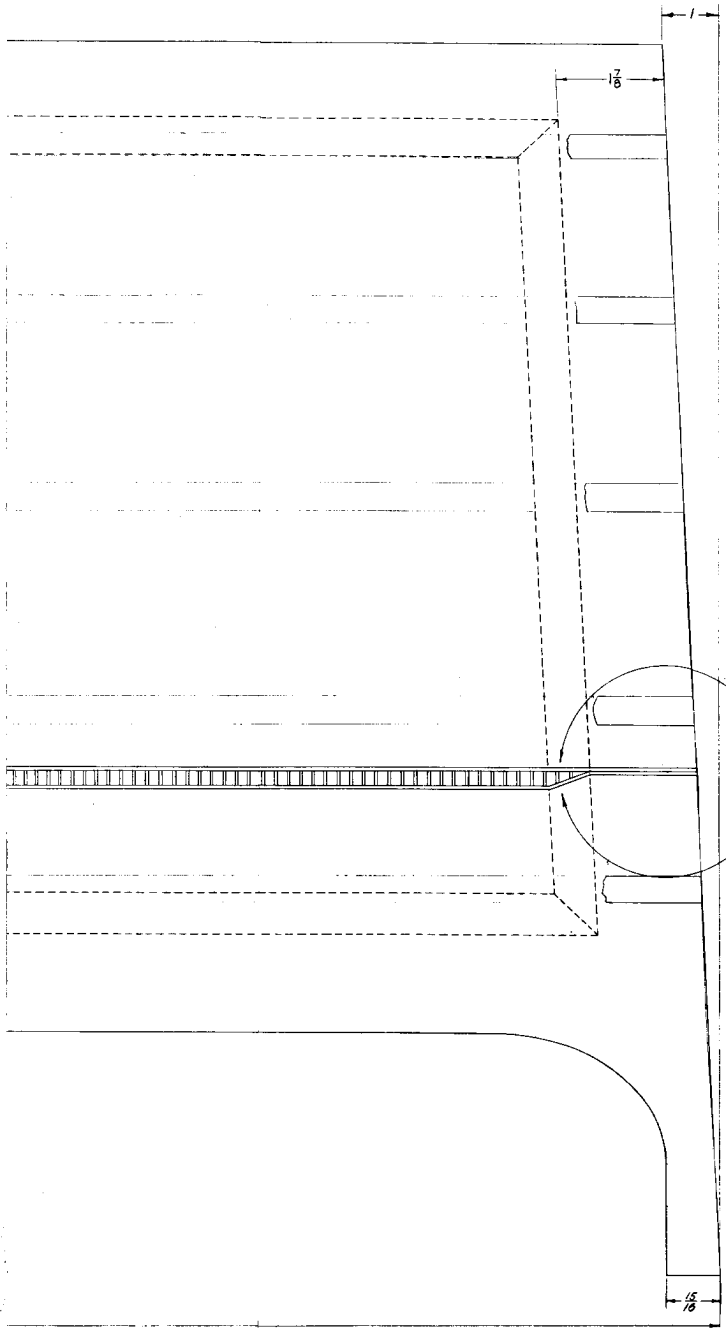

DETAIL	A	B	C
K	1 7/8	2 3/8	1 7/8
L	2 1/8	2 3/8	2 1/8
M	2 7/8	2 15/16	2 7/8
N	3 3/8	3 5/8	3 3/8
P	8	8 1/2	4 1/2

DETAIL A
 SEE ATTACHMENT (7)

<small>UNLESS OTHERWISE SPECIFIED DIMENSIONS ARE IN INCHES FRACTIONS ARE BASED ON 16 PARTS PER INCH</small>		NAVAL AIR DEVELOPMENT CENTER WARRINGTON, PA. 16874	
<small>DO NOT SCALE THIS DRAWING</small>		DRAWN <i>P. SONG</i>	CHECKED <i>[Signature]</i>
TITLE LEFT SKIN PANEL		DATE 80206	DRAWING NO. 667A107
APPROVED _____		SHEET FULL	OF 4

UNLESS OTHERWISE SPECIFIED DIMENSIONS ARE IN INCHES FRACTIONS ARE BASED ON 16 PARTS PER INCH

KEY
G-GRAPHITE EPOXY
W-WOVEN GLASS

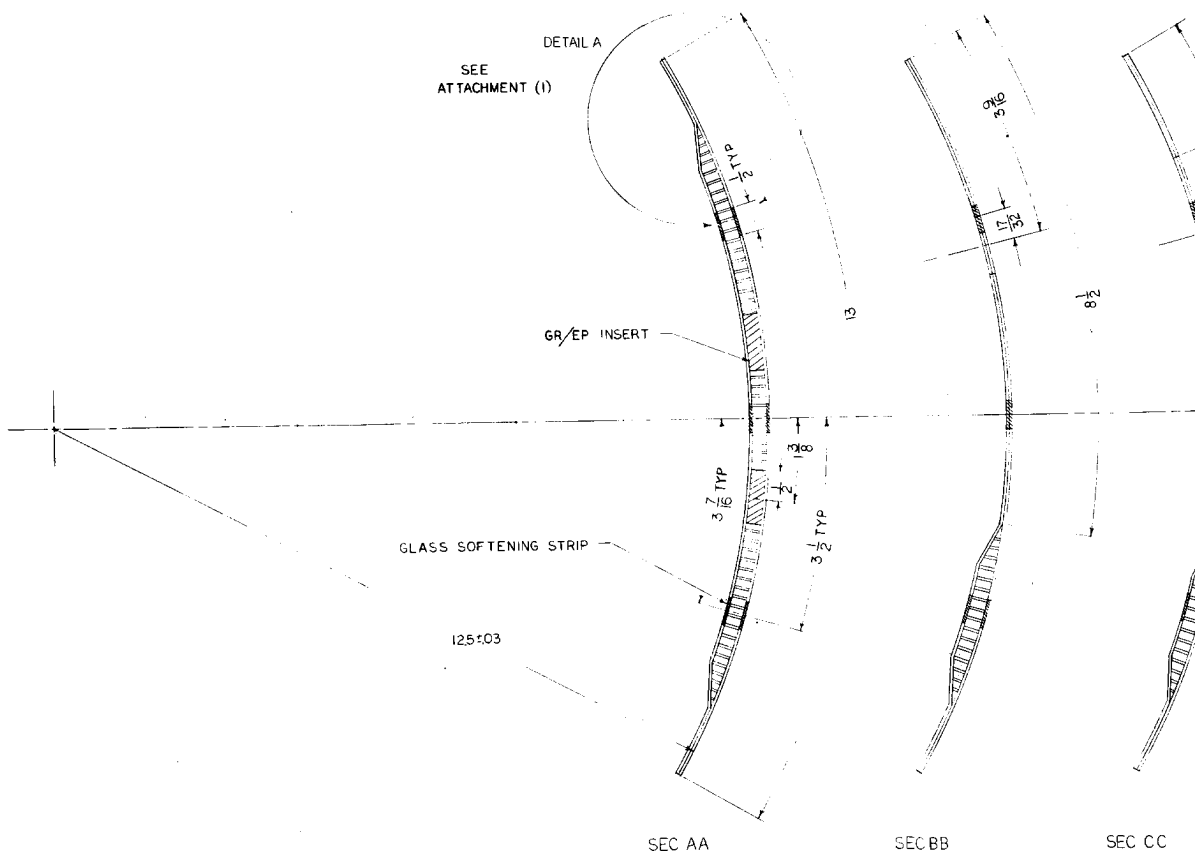

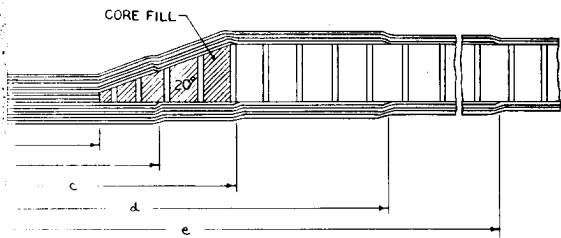

DETAIL A+B
4X

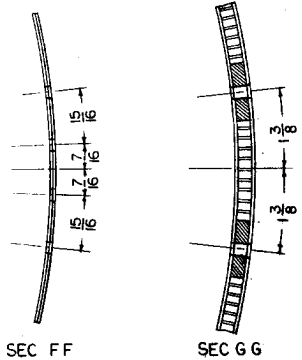
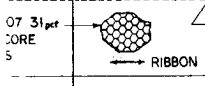
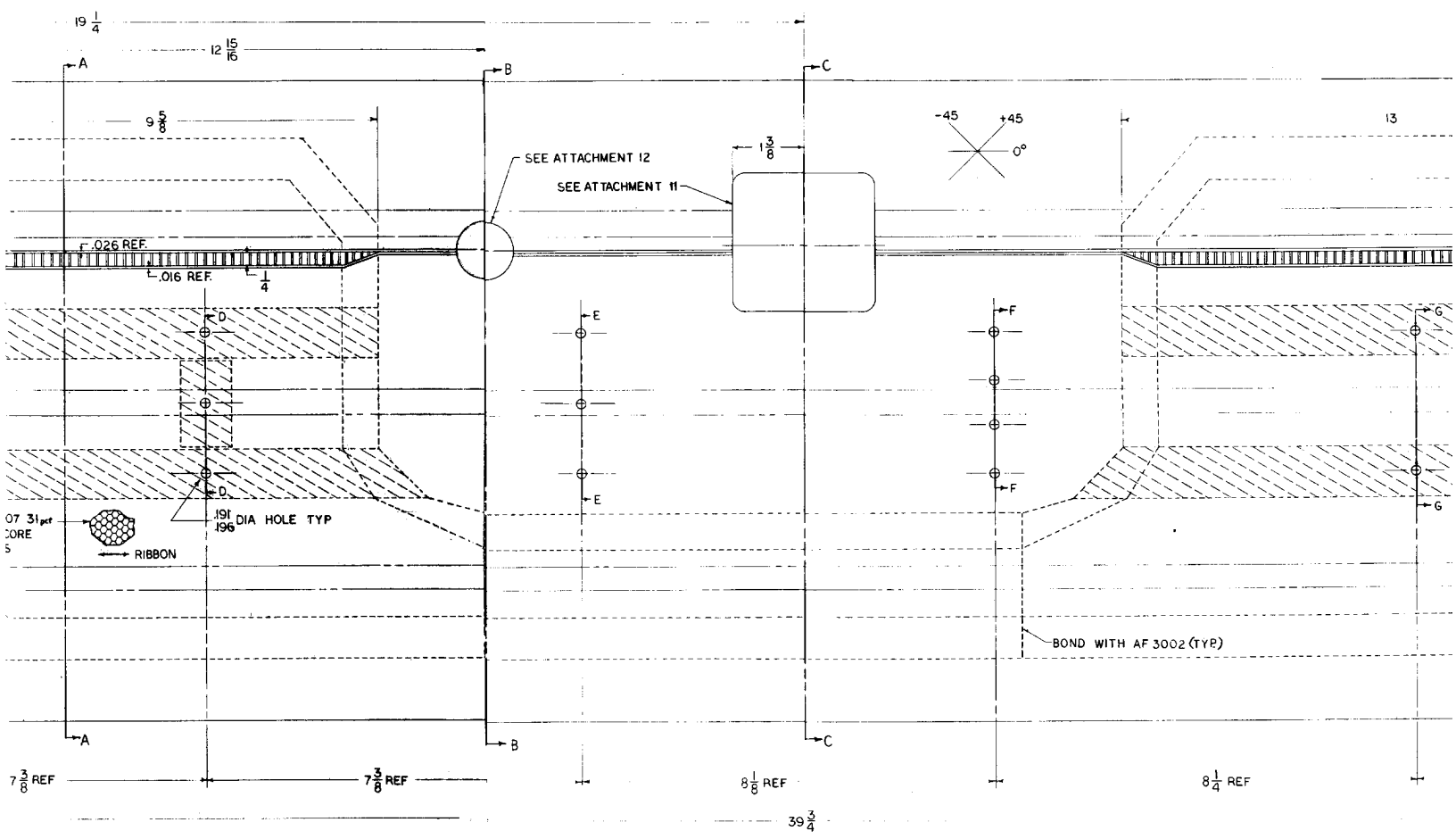

NOTE
ALL ATTACHMENT HOLES TO BE
MATCH DRILLED FROM EXISTING
PARTS

UNLESS OTHERWISE SPECIFIED DIMENSIONS ARE IN INCHES FRACTIONS SHALL BE DECIMALS PLACE DECIMALS IN PLACE DECIMALS IN PLACE DECIMALS IN	CONTRACT NO.
	PROJECT
DO NOT SCALE THIS DRAWING	CHECKED
	APPROVED
MATERIAL	APPROVED

AS ABOVE ARE REFERENCE DIMENSIONS

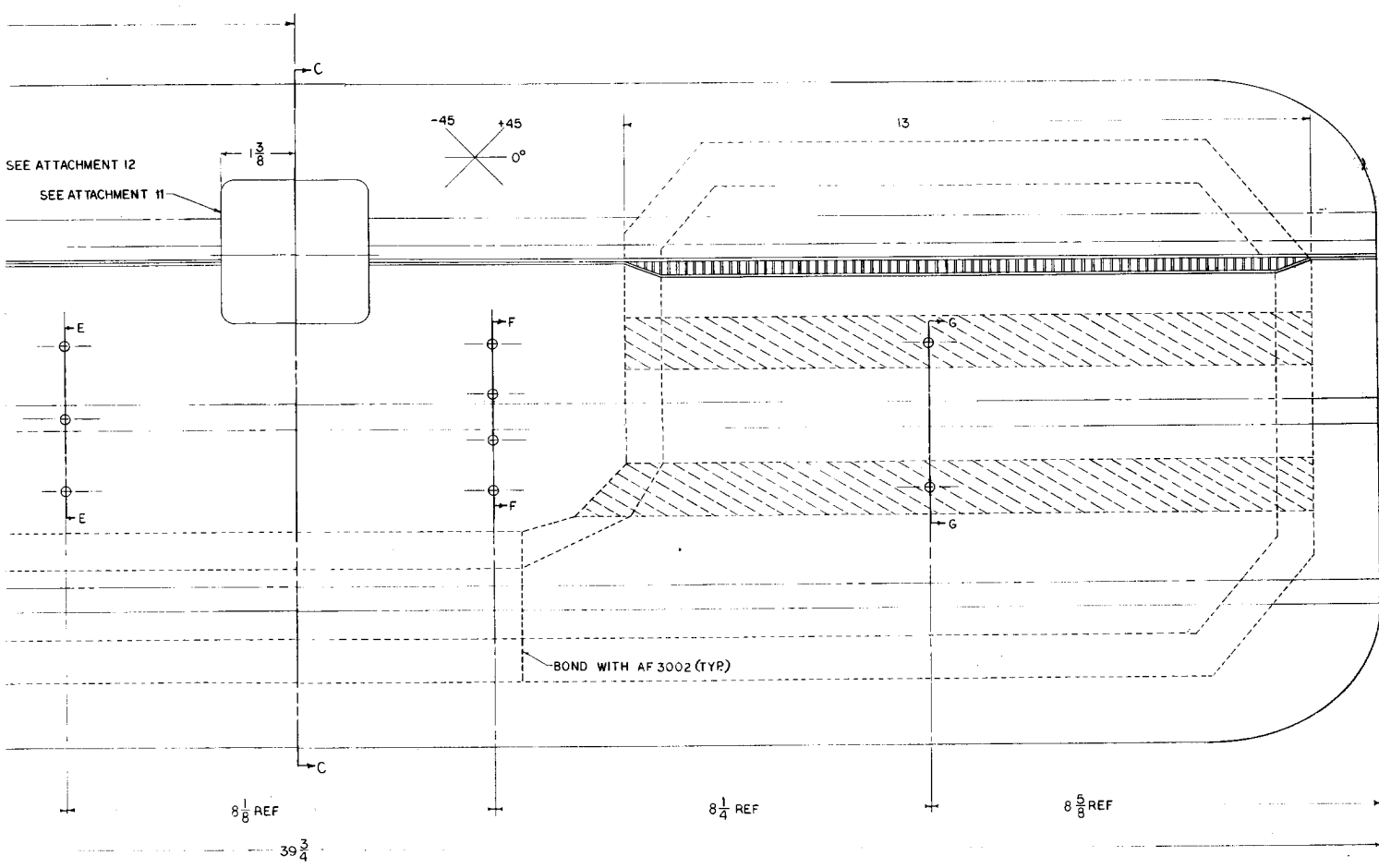

MENT HOLES TO BE
LED FROM EXISTING

<small>UNLESS OTHERWISE SPECIFIED DIMENSIONS ARE IN INCHES FRACTIONS OF AN INCH ARE TO BE PLACES DESIGNATED BY FIGURE DECIMALS</small>	CONTRACT NO.	NAVAL AIR DEVELOPMENT CENTER WARRIMSTER, PA. 19374		
	DESIGNER R. RICHEY	FUEL TANK ACCESS DOOR		
	CHECKED <i>[Signature]</i>	DATE	CODE SHEET NO. 80206	NAVCORE FILE NO. 667A 107
	APPROVED	SCALE FULL	REV.	SHEET 3 OF 4

6

5

4

D

C

B

A

DETAIL A

GLASS SOFTENING STRIPS
 $\frac{1}{2}$ WIDTH (TYP)

NOTE - GLASS STRIPS
CONTAINED WITHIN
GR/EP PLIES 2, 4,
14 + 16

12.5 R
 ± 0.03

.128
REF

$2\frac{1}{4}$

$3\frac{1}{2}$

$3\frac{1}{2}$

$11\frac{1}{2}$

REVISIONS			
ZONE	LTR	DESCRIPTION	DATE

PLY NO.

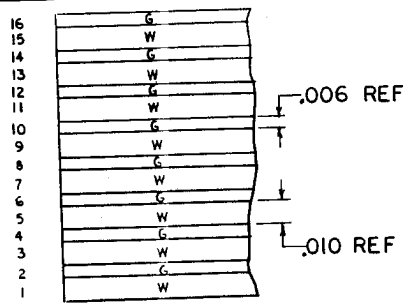

DETAIL A

KEY

G-GRAPHITE EPOXY 0°
 W-WOVEN FIBER GLASS EPOXY ± 45°

RIBBON DIRECTION

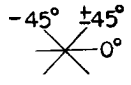

7 3/8

UNLESS OTHERWISE SPECIFIED DIMENSIONS ARE IN INCHES. TOLERANCES ARE:
 FRACTIONS ± ANGLES ±
 3 PLACE DECIMALS ±
 2 PLACE DECIMALS ±

DO NOT SCALE THIS DRAWING

MATERIAL:

CONTRACT NO.	
DRAWN	<i>PL. Ribben</i>
CHECKED	<i>PL. Hara</i>
APPROVED	
APPROVED	

NAVAL AIR DEVELOPMENT CENTER
 WARMINSTER, PA. 18974

ACCESS DOOR - BQM 34E
 CENTER FUSELAGE SECTION -
 HYBRID COMPOSITE DESIGN

SIZE	CODE IDENT. NO.	MADC DWS NO.	REV
D	80206	667A107	
SCALE	FULL	WT	SHEET 4 of 4

ATTACHM

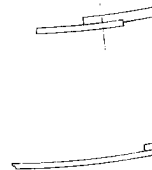
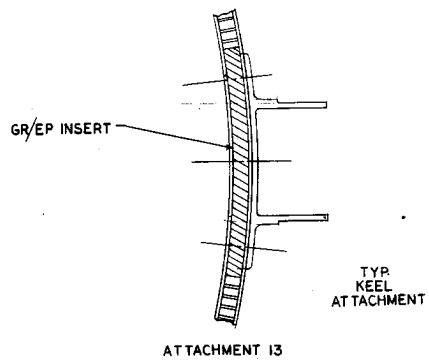
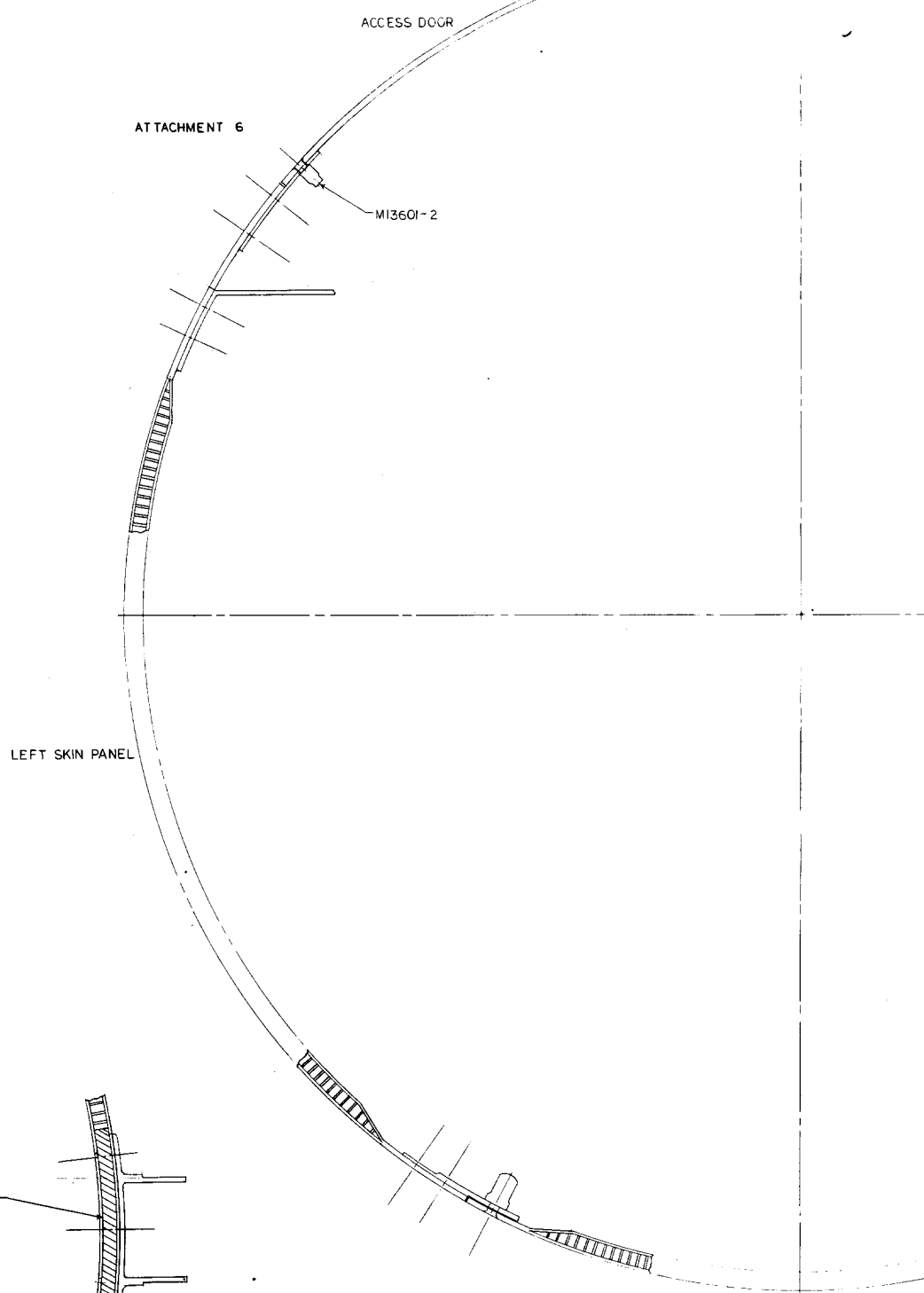

ATTACHMENT 5

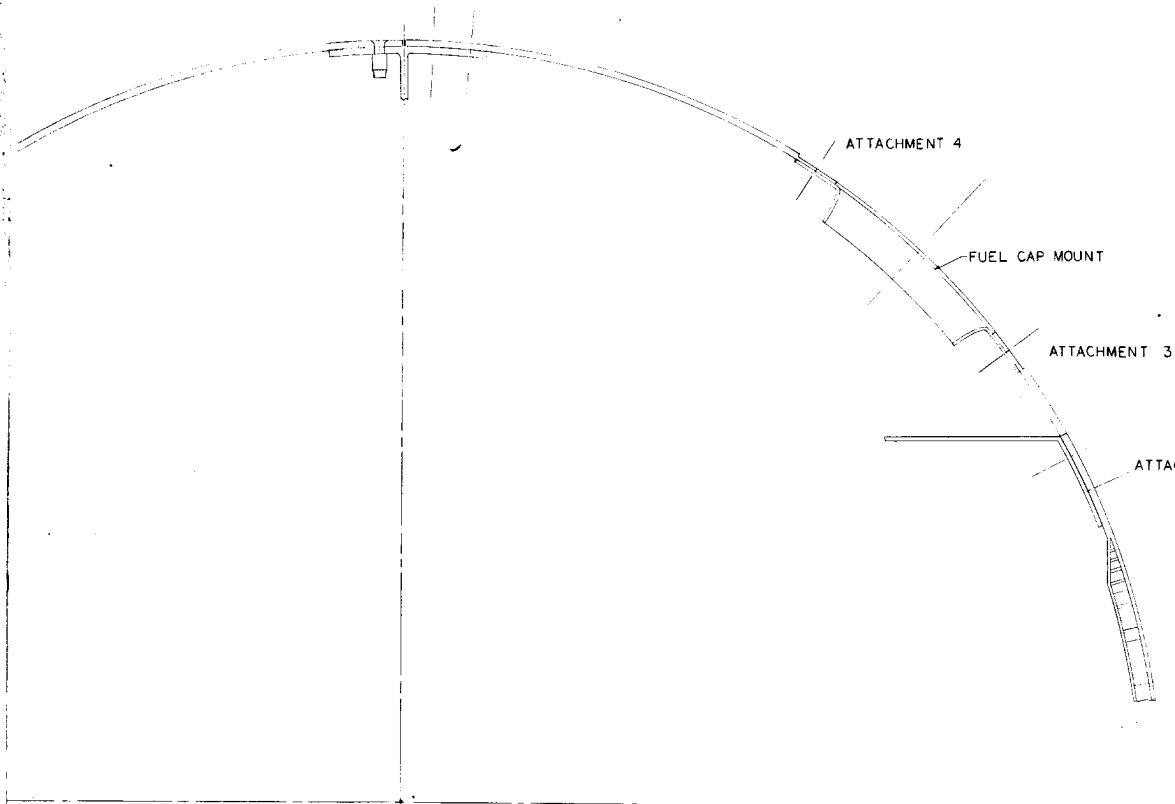

UPPER

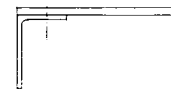

ATTACHMENT 9

NOTES

- MS 21140-06 RIVET
- CENTER LINES MARKED
- ALL ATTACHMENTS FROM EXISTING PART

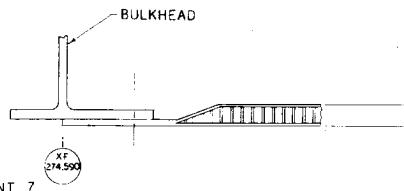
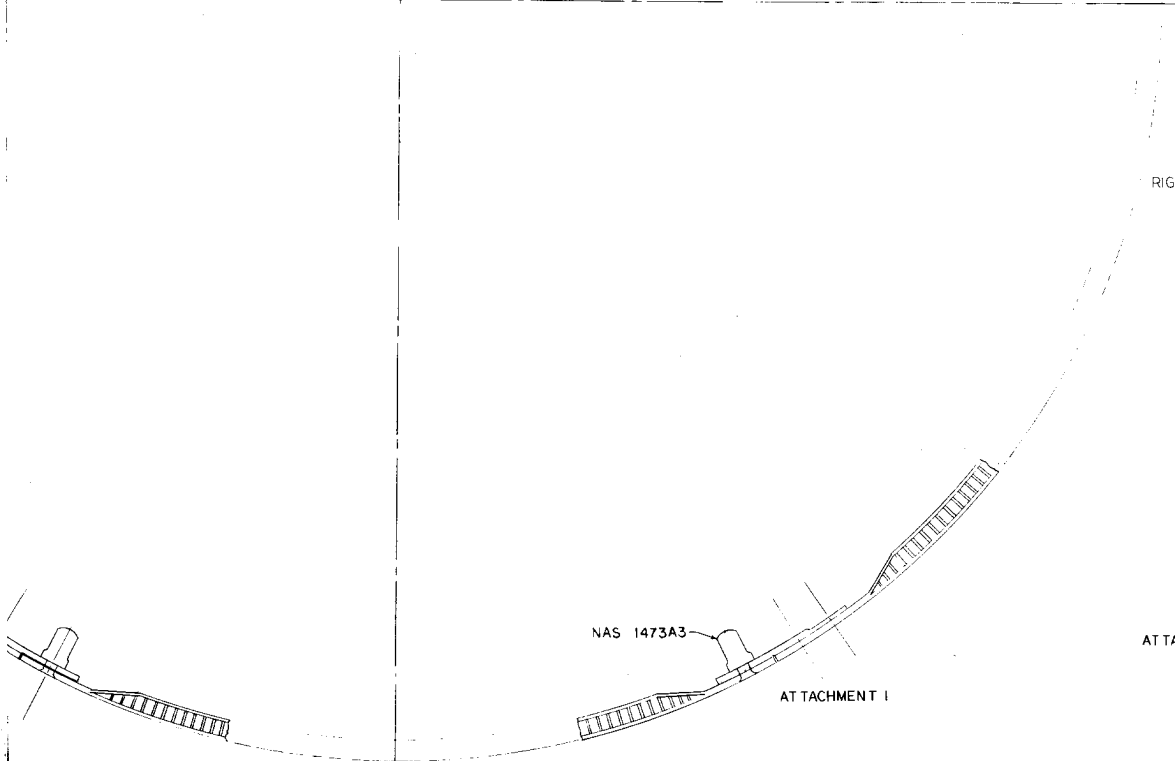

<small>UNLESS OTHERWISE SPECIFIED DIMENSIONS ARE IN INCHES TOLERANCES ARE ANGLES ±2° FRACTIONS 1/32 ANGLES ±2° 3 PLACE DECIMALS ±.03</small>		<small>CONTRACT NO.</small>
<small>DO NOT SCALE THIS DRAWING</small>		<small>DATE</small> RICHEY <small>FORM</small> <small>DESIGNED BY</small> <i>B. Roney</i> <small>5/28</small>
<small>MATERIAL:</small>		<small>APPROVED</small>
		<small>APPROVED</small>

EL CAP MOUNT

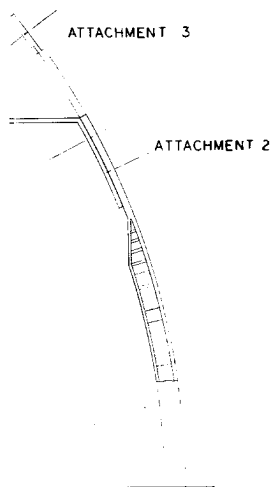

UPPER SECTION, RIGHT SKIN PANEL

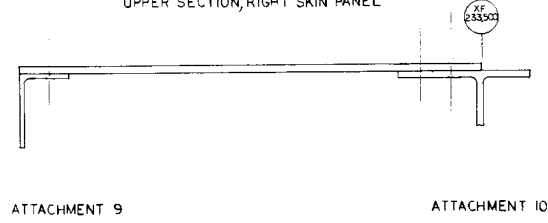

NOTES

- MS21140-06 RIVETS - TYP. ATTACHMENT FASTENER
- CENTER LINES MARK RIVET LOCATIONS
- ALL ATTACHMENTS HOLES ARE LOCATED FROM EXISTING PARTS

RIGHT SKIN PANEL

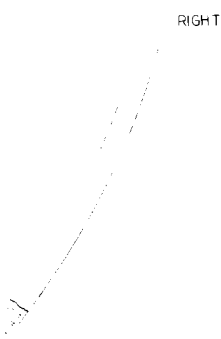

BULKHEAD

BULKHEAD

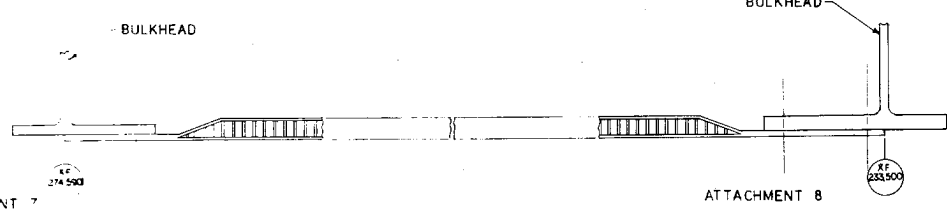

<small>UNLESS OTHERWISE SPECIFIED DIMENSIONS ARE IN INCHES. TOLERANCES ARE: FRACTIONS .015 ANGLES ±2° 1 PLACE DECIMALS ±.005 2 PLACE DECIMALS ±.003</small>		NAVAL AIR DEVELOPMENT CENTER WARMINSTER, PA. 18974	
DO NOT SCALE THIS DRAWING		ATTACHMENTS	
DRAWN RICHEY 8/24/73 CHECKED <i>[Signature]</i> 8/24/73	CONTRACT NO.	SITE 80206	MARC DWG. NO. 667A109
APPROVED _____ APPROVED _____	MATERIAL	SCALE FULL	WT. _____ SHEET _____ OF _____

FORM 3486-107 (11) (REV. 4-73)

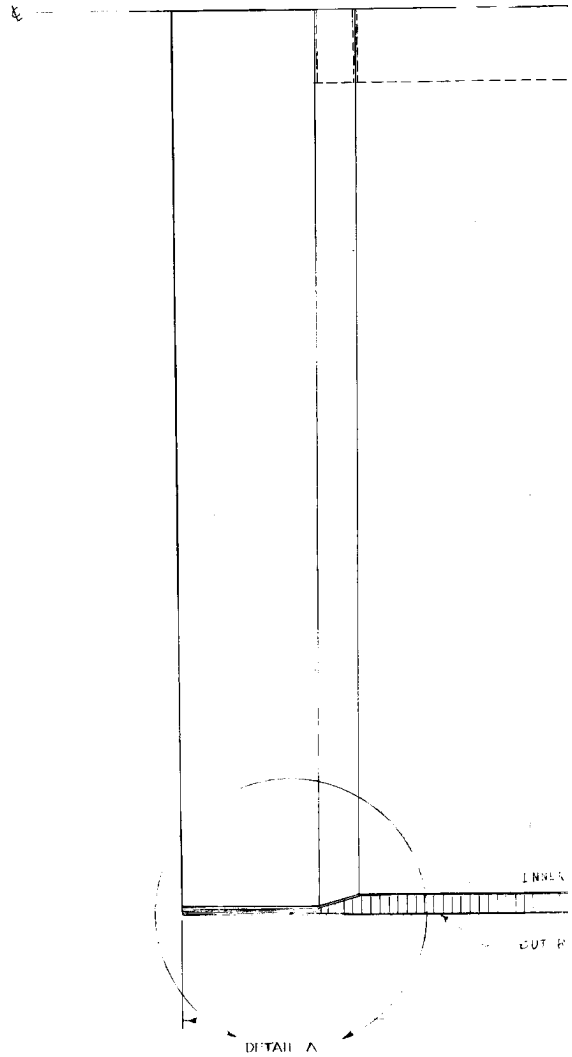

PLY NO	
16	G
15	W
14	G
13	W
12	G
11	W
10	G
9	W
8	G
7	W
6	G
5	W
4	G
3	W
2	G
1	W

KEY
 G-GRAPHITE 0°
 W-WOVEN GLASS ±45°

DETAIL B
 LAYUP SEQUENCE

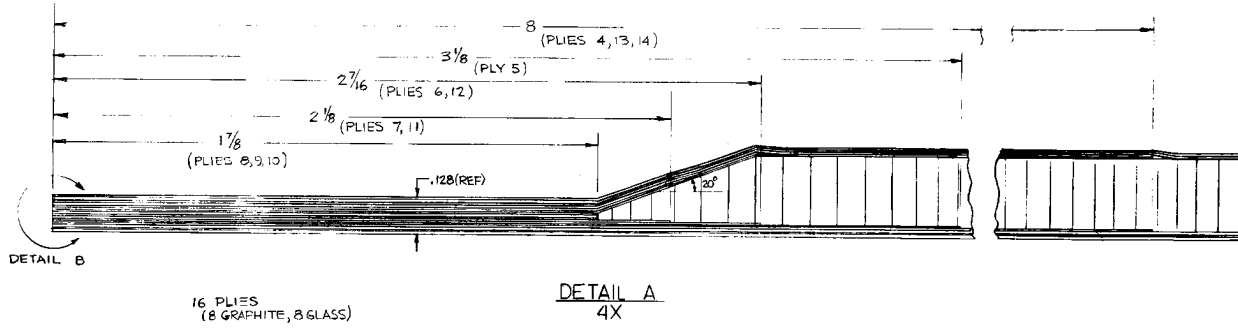

RIBBON DIRECTION



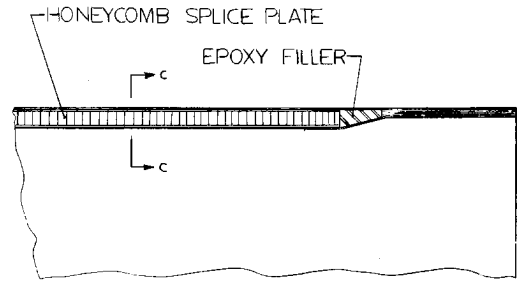
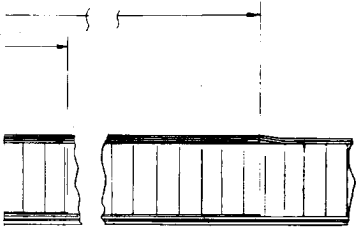

SECTION B-B SPLICE DETAIL

A

B B

RIBBON DIRECTION

$\pm 45^\circ$

0.026 (REF)
0.016 (REF)

A

0.032 (REF)
0.25 (CORE)
0.032 (REF)

SAME AS DETAIL A

NOTES:

1. MATERIALS
 GRAPHITE-HERCULES
 GLASS-CORDOPREG
 ADHESIVE-HYSOL EA
2. RELEASE AGENT TO I
 AREA-FREECOTE OR
3. EA951 SHALL BE USE
4. SOFTENING STRIPS
 GLASS REPLACES G
 SOFTENING STRIP F
5. SPLICE SHALL BE B
 EA-951.
6. CURE TEMPERATURE
7. EPOXY FILLER-AF 301
8. TOLERANCES $\pm 1/32$ OR

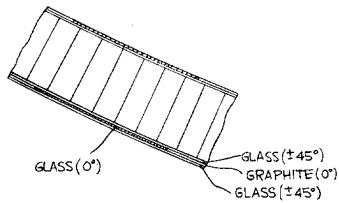

DETAIL C
4X

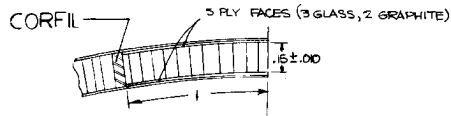

SECTION C-C
2X

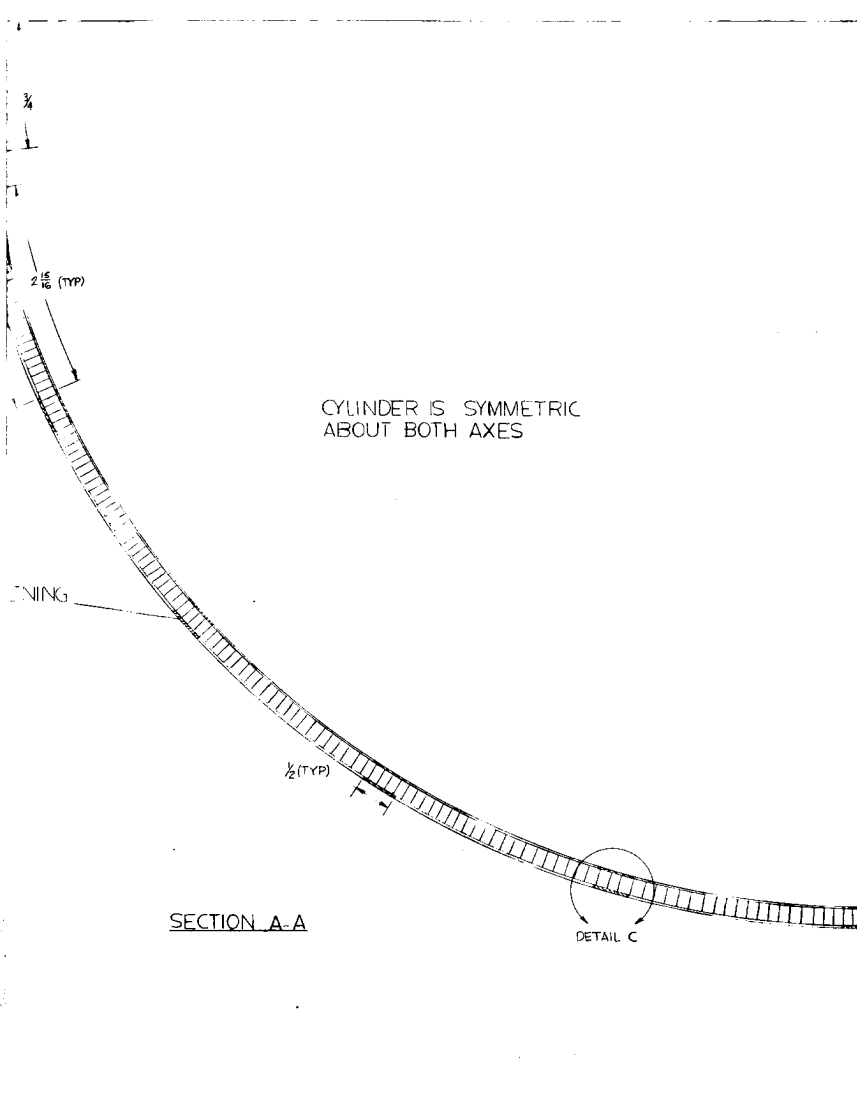

CYLINDER IS SYMMETRIC
ABOUT BOTH AXES

SECTION A-A

DETAIL C

BQM-34E CYLINDER TEST SPECIMEN		MAT FA CC
SCALE - FULL	8-27-74	

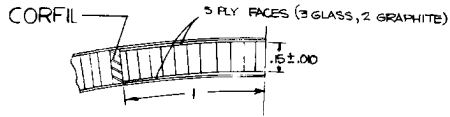
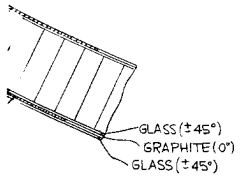

SECTION C-C
2X

NOTES:

1. MATERIALS
 GRAPHITE-HERCULES 3501 AS
 GLASS-CORDOPREG E293
 ADHESIVE-HYSOL EA951
2. RELEASE AGENT TO BE USED WITH STEEL INSE
 AREA-FREECOTE OR #1711.
3. EA951 SHALL BE USED TO BOND CORE TO FACE
4. SOFTENING STRIPS
 GLASS REPLACES GRAPHITE IN THESE AREAS
 SOFTENING STRIP RUNS ENTIRE LENGTH OF F
5. SPLICE SHALL BE BONDED AT 350° WITH
 EA-951.
6. CURE TEMPERATURE -350°
7. EPOXY FILLER-AF 3002.
8. TOLERANCES ± 1/32 OR AS NOTED.

CYLINDER IS SYMMETRIC
ABOUT BOTH AXES

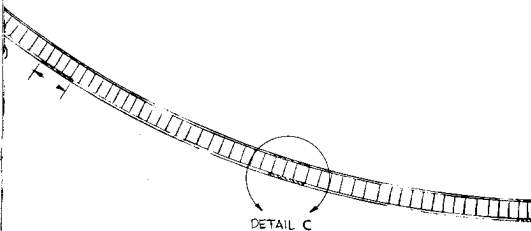

BQM-34E CYLINDER TEST SPECIMEN

MATERIAL:
 FACING-GRAPHITE/GLASS HYBR
 CORE-AL-1/8-5056-.0007-3.1(HI-X)

SCALE-FULL

8-27-74

NOTES:

1. MATERIALS

GRAPHITE-HERCULES 3501 AS

GLASS-CORDOPREG E293

ADHESIVE-HYSOL EA95I

2. RELEASE AGENT TO BE USED WITH STEEL INSERT IN SPLICE AREA-FREECOTE OR #1711.

3. EA95I SHALL BE USED TO BOND CORE TO FACES.

4. SOFTENING STRIPS

GLASS REPLACES GRAPHITE IN THESE AREAS.

SOFTENING STRIP RUNS ENTIRE LENGTH OF PLYS 2,4,16.

5. SPLICE SHALL BE BONDED AT 350° WITH EA-95I.

6. CURE TEMPERATURE -350°

7. EPOXY FILLER-AF 3002.

8. TOLERANCES $\pm 1/32$ OR AS NOTED.

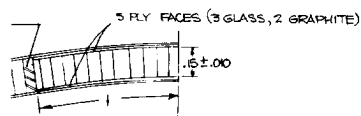

SECTION C-C
2X

BQM-34E CYLINDER TEST SPECIMEN		MATERIAL: FACING-GRAPHITE/GLASS HYBRID CORE-AL-1/8-5056-0007-3.1(HF-XCF)
SCALE-FULL	8-27-74	

DISTRIBUTION LIST

Government Activities

	<u>No. of Copies</u>
NAVAIRSYSCOM, AIR-954 (2 for retention), 2 for AIR-530, 1 for AIR-320B, AIR-52032D, AIR-5302, AIR-53021, AIR-530215).	9
AFFDL, WPAFB, OH 45433	
(Attn: FB/Mr. P. A. Parmley)	2
(Attn: FBC/Mr. C. Wallace)	1
(Attn: FBC/Mr. E. E. Zink)	1
AFML, WPAFB, OH 45433	
(Attn: LAM (Technical Library))	1
(Attn: LT-1/Mr. W. R. Johnston)	1
(Attn: LIF/Mr. T. Cordell)	1
(Attn: FBSC/Mr. L. Kelly)	1
(Attn: MAC/Mr. G. P. Peterson)	1
(Attn: MKA/Mr. F. J. Fechek)	1
(Attn: MBC/Mr. T. G. Reinhard, Jr.)	1
AFOSR, Washington, D.C. 20333	
(Attn: Mr. J. Pomerantz)	1
DDC.	12
FAA, Airframes Branch, FS-120, Washington, D.C. 20553	
(Attn: Mr. J. Dougherty)	1
NASA (ADM), Washington, D.C. 20546	
(Attn: Secretary)	1
NASA, George C. Marshall Space Flight Center, Huntsville, AL 35812	
(Attn: S&E-ASTN-ES/Mr. E. E. Engler)	1
(Attn: S&E-ASTN-M/Mr. R. Schwinghamer)	1
(Attn: S&E-ASTM-MNM/Dr. J. M. Stuckey)	1
NASA, Langley Research Center, Hampton, VA 23365	
(Attn: Mr. J. P. Peterson, Mr. R. Pride, and Dr. M. Card) . .	3
NASA, Lewis Research Center, Cleveland, OH 44153	
(Attn: Technical Library, and M. Hershberg)	2
NAVPGSCHL, Monterey, CA 95940	
(Attn: Prof. R. Ball, Prof. M. H. Bank)	2
NAVSEASYSYSCOM, Washington, D.C. 20362	
(Attn: Code 035, Mr. C. Pohler)	1
NAVSEC, Hyattsville, MD 20782	
(Attn: Code 6101E03, Mr. W. Graner)	1
NAVSHIPRANDCEN, Bethesda, MD 20034	
(Attn: Code 173.2, Mr. W. P. Cauch)	1
NAVSHIPRANDCEN, Annapolis, MD 21402	
(Attn: Code 2870, Mr. H. Edelstein)	1
NOL, White Oak, MD 20910	
(Attn: Mr. F. R. Barnet)	1
NRL, Washington, D.C. 20375	
(Attn: Dr. I. Wolock)	1
ONR, Washington, D.C. 20362	
(Attn: Dr. N. Perrone)	1

Non-Government Agencies (Cont.)

Hercules Powder Company, Inc., Cumberland, MD 21501 (Attn: Mr. D. Hug)	1
H. I. Thompson Fiber Glass Company, Gardena, CA 90249 (Attn: Mr. N. Myers)	1
ITT Research Institute, Chicago, IL 60616 (Attn: Mr. K. Hofar)	1
J. P. Stevens & Co., Inc., N.Y., NY 10036 (Attn: Mr. H. I. Shulock).	1
Kaman Aircraft Corporation, Bloomfield, CT 06002 (Attn: Tech. Library).	1
Lehigh University, Bethlehem, PA 18015 (Attn: Dr. G. C. Sih).	1
Lockheed-California Company, Burbank, CA 91520 (Attn: Mr. E. K. Walker, R. L. Vaughn)	2
Lockheed-Georgia Company, Marietta, GA (Attn: Advanced Composites Information Center, Dept. 72-14, Zone 42).	1
LTV Aerospace Corporation, Dallas, TX 75222 (Attn: Mr. O. E. Dhonau/2-53442, C. R. Foreman).	2
Martin Company, Baltimore, MD 21203 (Attn: Mr. J. E. Pawken)	1
Materials Sciences Corp., Blue Bell, PA 19422	1
McDonnell Douglas Corporation, St. Louis, MO 63166 (Attn: Mr. R. C. Goran, O. B. McBee, C. Stenberg).	3
McDonnell Douglas Corporation, Long Beach, CA 90801 (Attn: H. C. Schjulderup, G. Lehman)	2
Minnesota Mining and Manufacturing Company, St. Paul, MN 55104 (Attn: Mr. W. Davis)	1
Northrop Aircraft Corp., Norair Div., Hawthorne, CA 90250 (Attn: Mr. R. D. Hayes, J. V. Noyes, R. C. Isemann).	3
Rockwell International, Columbus, OH 43216 (Attn: Mr. O. G. Acker, K. Clayton).	2
Rockwell International, Los Angeles, CA 90053 (Attn: Dr. L. Lackman)	1
Rockwell International, Tulsa, OK 74151 (Attn: Mr. E. Sanders, Mr. J. H. Powell)	2
Owens Corning Fiberglass, Granville, OH 43023 (Attn: Mr. D. Mettes).	1
Rohr Corporation, Riverside, CA 92503 (Attn: Dr. F. Riel and Mr. R. Elkin)	2
Ryan Aeronautical Company, San Diego, CA 92112 (Attn: Mr. R. Long).	1
Sikorsky Aircraft, Stratford, CT 06497 (Attn: Mr. J. Ray)	1
University of Oklahoma, Norman, OK 93069 (Attn: Dr. G. M. Nordby)	1
Union Carbide Corporation, Cleveland, OH 44101 (Attn: Dr. H. F. Volk)	1

Government Activities (Cont.)

PLASTECH, Picatinny Arsenal, Dover, NJ 07801 (Attn: Librarian, Bldg. 176, SARPA-FR-M-D and Mr. H. Pebly)	2
Scientific & Technical Information Facility, College Park, MD (Attn: NASA Representative)	1
USAAVMATLAB, Fort Eustis, VA 23603 (Attn: Mr. R. Beresford)	1
USAMATRESAG, Watertown, MA (Attn: Dr. E. Leno)	1
USARESOFC, Durham, NC 27701	1

Non-Government Agencies

Avco Aero Structures Division, Nashville, TN 37202 (Attn: Mr. W. Otterville)	1
Battelle Columbus Laboratories, Metals and Ceramics Information Center, 505 King Avenue, OH 43201.	1
Bell Aerospace Company, Buffalo, NY 14240 (Attn: Zone I-85, Mr. F. M. Anthony)	1
Bell Helicopter Company, Fort Worth, TX 76100 (Attn: Mr. Charles Harvey)	1
Bendix Products Aerospace Division, South Bend, IN 46619 (Attn: Mr. R. V. Cervelli)	1
Boeing Aerospace Company, P.O. Box 3999, Seattle, WA 98124 (Attn: Code 206, Mr. R. E. Horton)	1
Boeing Company, Renton, Washington 98055 (Attn: Dr. R. June)	1
Boeing Company, Vertol Division, Phila., PA 19142 (Attn: Mr. R. L. Pinckney, Mr. D. Hoffstedt)	2
Boeing Company, Wichita, KS 67210 (Attn: Mr. V. Reneau/MS 16-39)	1
Cabot Corporation, Billerica Research Center, Billerica, MA 01821	1
Drexel University, Phila., PA 19104 (Attn: Dr. P. C. Chou)	1
E.I. DuPont Company, Wilmington, DE 19898 (Attn: Dr. Carl Zweben) Bldg. 262/Room 316	1
Fairchild Industries, Hagerstown, MD 21740 (Attn: Mr. D. Ruck)	1
Georgia Institute of Technology, Atlanta, GA (Attn: Prof. W. H. Horton)	1
General Dynamics/Convair, San Diego, CA 92138 (Attn: Mr. D. R. Dunbar, W. G. Scheck)	2
General Dynamics, Fort Worth, TX 76101 (Attn: Mr. P. D. Shockey, Dept. 23, Mail Zone P-46)	1
General Electric Company, Phila., PA 19101 (Attn: Mr. L. McCreight)	1
Great Lakes Carbon Corp., N.Y., NY 10017 (Attn: Mr. W. R. Bem, Mgr., Markey Development)	1
Grumman Aerospace Corporation, Bethpage, L.I., NY 11714 (Attn: Mr. R. Hadcock, Mr. S. Dastin)	2