

Design and Fabrication of Composite Blades for the Mod-1 Wind Turbine Generator

DISTRIBUTION STATEMENT A

Approved for public release;
Distribution Unlimited

William R. Batesole and Clifford T. Gunsallus
Kaman Aerospace Corporation

19960223 144

November 1981

DEPARTMENT OF ENERGY
ENERGY TECHNOLOGY EVALUATION CENTER
RESEARCH TRIANGLE PARK, N.C. 27709

Prepared for
National Aeronautics and Space Administration
Lewis Research Center

DTIC QUALITY INSPECTED 3

for
U.S. Department of Energy
Energy Technology
Distributed Solar Technologies Division

PLASTEO
143409

NOTICE

This report was prepared to document work sponsored by the United States Government. Neither the United States nor its agent, the United States Department of Energy, nor any Federal employees, nor any of their contractors, subcontractors or their employees, makes any warranty, express or implied, or assumes any legal liability or responsibility for the accuracy, completeness, or usefulness of any information, apparatus, product or process disclosed, or represents that its use would not infringe privately owned rights.

DISCLAIMER NOTICE

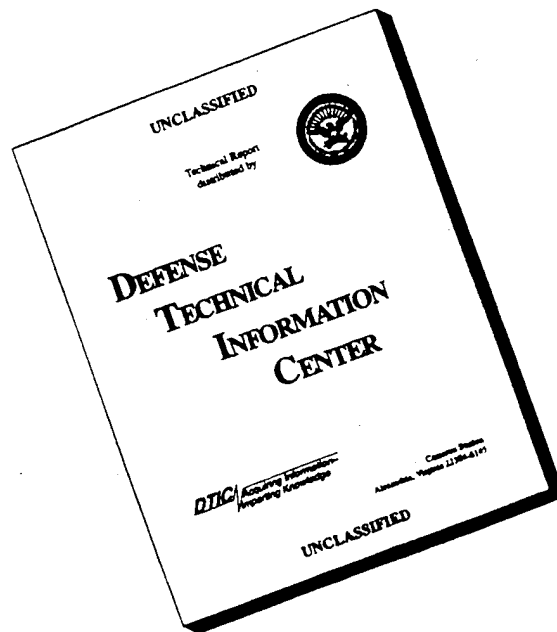

THIS DOCUMENT IS BEST QUALITY AVAILABLE. THE COPY FURNISHED TO DTIC CONTAINED A SIGNIFICANT NUMBER OF PAGES WHICH DO NOT REPRODUCE LEGIBLY.

National Aeronautics and
Space Administration

COPY



Lewis Research Center
Cleveland, Ohio
44135

Reply to Attn of: 4512

September 30, 1982

Mr. Bruce Goodale
Kaman Aerospace Corp.
Old Madison Road, P.O. Box 2
Bloomfield, CT 06002

Dear Bruce:

The final report on Contract DEN 3-131 "Design and Fabrication of Composite Blades for the Mod-1 Wind Turbine Generator", NASA CR 167987, is approved for printing and distribution. Enclosed is a copy of "Experience and Assessment of the DOE-NASA Mod-1 2000 Kilowatt Wind Turbine Generator at Boone, North Carolina," NASA TM-82721. This report may be retained for your files and should be used as a sample for the cover lay-out of the DEN 3-131 report. I am also enclosing a copy of the Document Release Authorization (FF 427) which should be attached to the copy of your report which is sent to the NASA Scientific and Technical Information Facility. When you have finished printing NASA CR 167987, please distribute to the following:

Department of Energy
Wind Energy Technology Division
Attn: Mr. Dan Ancona
Forrestal Building
Room 5F-059
Washington, DC 20585

National Aeronautics and Space Administration
Washington, D. C. 20546
Attn: Mr. Robert Wasel

✓ Plastics Technical Evaluation Center (PLASTEC)
ARRADCOM
Dover, NJ 07801
Attn: Mr. A. M. Anzalone, Bldg. 3401

NASA Scientific and Technical Information Facility
P. O. Box 8757
BWI Airport, MD 21240

General Electric Corporation
Advanced Energy Program Department
P. O. Box 527
King of Prussia, PA 19406
Attn: Mr. Richard Poor

Blue Ridge Electric Membership Corporation
1216 Blowing Rock Blvd., N.E.
Box 112
Lenoir, NC 28645
Attn: Mr. Grant Ayers, Jr.

National Aeronautics and Space Administration
Lewis Research Center
21000 Brookpark Road
Cleveland, OH 44135
Attn: Mr. J. R. Faddoul (50 copies)

Since this report has been in the works for some time, I would appreciate it if you would do what you can to expedite printing and distribution.

Sincerely,

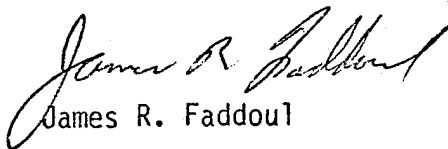

James R. Faddoul

Enclosures

DOE/NASA/0131-1
NASA CR-167987
R-1685

Design and Fabrication of Composite Blades for the Mod-1 Wind Turbine Generator

William R. Batesole and Clifford T. Gunsallus
Kaman Aerospace Corporation
Bloomfield, Connecticut 06002

November 1981

Prepared for
National Aeronautics and Space Administration
Lewis Research Center
Cleveland, Ohio 44135
Under contract DEN3-131

for
U.S. Department of Energy
Energy Technology
Distributed Solar Technologies Division
Washington, D.C. 20545
Under Interagency Agreement DE-AI01-76-ET2030

TABLE OF CONTENTS

	<u>PAGE NO.</u>
1.0 SUMMARY	1
2.0 INTRODUCTION.	4
3.0 BLADE DESIGN.	5
3.1 Design Concept	5
3.2 Spar	6
3.3 Afterbody.	8
3.4 Overwraps, Closures.	9
3.5 Adapter Fitting and Attachment Hardware.	10
3.6 Lightning Protection System.	11
3.7 Ice Detection System	12
3.8 Paint System	12
3.9 Instrumentation.	13
4.0 STRUCTURAL ANALYSIS	14
4.1 Design Requirements.	14
4.2 Material Allowables.	15
4.3 Substantiation Approach.	20
4.4 Analysis	21
5.0 STRUCTURAL TESTING.	23
5.1 Spar Buckling.	23
5.2 Root Laminate Characterization	24
5.3 Quarter-scale Root End Fatigue	25
6.0 LIGHTNING PROTECTION.	27
7.0 BLADE MANUFACTURE	31
7.1 Spar	31
7.2 Afterbody Panels and Installation.	34
7.3 Secondary Composite Operations	36
7.4 Adapter Fittings and Installation.	36
7.5 Lightning Protection, Ice Detector	38
7.6 Paint.	39
8.0 QUALITY ASSURANCE	40
9.0 WEIGHT AND BALANCE.	43
10.0 PRE-DELIVERY TESTING (PLANNED).	44
10.1 Bending Proof Load.	44
10.2 Natural Frequency	44
11.0 SHIPPING, HANDLING (PROPOSED)	46
12.0 COSTS	47

TABLE OF CONTENTS (CONTINUED)

PAGE NO.

13.0 CONCLUSIONS.	49
14.0 RECOMMENDATIONS.	49
15.0 REFERENCES	50

LIST OF FIGURES:

FIGURE

1	Mod-1 composite blade	51
2	150 foot composite blade.	52
3	Planform, Mod-1 composite blade	53
4	Cross section	54
5	Exploded view	55
6	Adapter fitting	56
7	Lighting protection system.	57
8	NASA Lightning stroke model	58
9	Mod-1 spar bending test	59
10	Spar winding system	60
11	Spar winding in progress.	61
12	Manual resin application and rolling.	62
13	Feed system for hoop rovings.	63
14	Removal of spar from mandrel.	63
15	Spar winding mandrel.	64
16	Transportation of 130 ft. mandrel by rail	65
17	Afterbody panel bond fixture.	66
18	Afterbody installation fixture.	67
19	Five chordwise overwraps on unpainted blade	68
20	Finished adapter fitting.	69
21	Set-up for boring spar-to-adapter holes	69
22	Bending proof-test set up	70
23	Free-free natural frequency check	71

APPENDIX

1.0 SUMMARY

This report describes the Mod-1 composite wind turbine blade program carried out by Kaman Aerospace Corporation under contract to NASA Lewis Research Center. The program involved the design, tooling, manufacture and pre-delivery testing of two 100 ft blades. Its primary objective was to provide operational composite blades for test and evaluation on the Mod-1 wind turbine at Boone, North Carolina. All elements of the program were performed by Kaman at its Bloomfield, Connecticut, facilities with the exception of the fabrication of certain steel parts which were subcontracted to metalworking shops.

In the execution of this program, Kaman was aided by the supportive work of NASA-LeRC who assigned themselves the responsibility for assuring compatibility of the final blade design with the Mod-1 system. NASA provided the design load cases and performed analytical checks as the design progressed, especially in the areas of blade stiffness and natural frequency.

The engineering work of this program drew heavily upon the results of a fore-runner program (1977 - 1978), performed by Kaman under NASA Contract NAS3-20600, which designed and built a 150 ft composite wind turbine blade. Design, analysis, and manufacturing methods were developed in that program which were directly applicable to the Mod-1 blade effort.

At this writing, the design and construction phases of the Mod-1 composite blade have been successfully accomplished. Both blades are completed and are currently stored at the Kaman facility pending NASA/DOE decisions with regard to continuation of the Mod-1 wind turbine test program. A completed blade is shown in Figure 1.

Two primary requirements were stipulated by NASA and strongly influenced blade design. These were: first, the blades were to directly utilize the 150 ft blade technology and configuration; second, the blades were to be directly interchangeable with the metal blades already developed and operating on the Mod-1 machine. The latter constraint, which necessitated that the composite blade match the static and dynamic characteristics of the steel blade, proved to be particularly challenging since the modulus of elasticity of the composite laminate is approximately one-sixth that of steel. Thus, considerable care was required in selecting cross sections and wall thicknesses of the spar, a D-shape tubular member which is the blade's main load carrying structural element. Achieving appropriate stiffness and dynamic characteristics was, however, greatly facilitated by the nature of composite construction which readily permitted dimensional variation to be built into the spar without compromising ease of manufacture.

The Mod-1 blades use filament wound Transverse Filament Tape (TFT) for construction of the spar. TFT is a material used in the commercial pipe industry and developed for rotor blade use as part of the 150 ft blade program. The afterbody portion of the blade's airfoil is comprised of upper and lower panels of fiberglass and paper-honeycomb sandwich construction. A means of attaching the blade to the wind turbine hub is provided by a steel adapter fitting which is permanently mounted in the spar's inboard end. Two points of

departure from the 150 ft blade design were permitted for the Mod-1 blades to facilitate manufacturing processes as improvements. These were: deletion of a trailing edge spar member and its accompanying inboard truss hardware, and elimination of the four-step spar winding process in favor of a continuous winding procedure which eliminated the two mid-span splices present in the 150 ft spar. These changes simplified the design, increased reliability, and reduced cost of the Mod-1 composite blade.

A lightning protection system is incorporated. The system was developed under this contract using the services of a lightning test laboratory for developmental testing and substantiation of the design. This was a new item of technology, not having been addressed in the 150 ft blade program. The resulting system has been shown capable of sustaining the 200,000 ampere lightning stroke specified by NASA.

Weight and balance testing of the finished blades has been accomplished. Final blade weight is 26,846 pounds which represents an increase over the steel blade weight; however, since the composite blade's spanwise CG is located farther inboard than that of the steel blade, the growth in first mass moment is minimal (+8.9%) and satisfactory for Mod-1 use.

Certain planned testing of the finished blades is currently being held in abeyance pending a NASA/DOE decision on further operation of the MOD-1 wind turbine. To be included in the testing would be installation and calibration of blade instrumentation along with bending proof tests, natural frequency tests, and final mass balancing of the blade set. This planned work is discussed in Section 10.

Manufacturing cost of the Mod-1 blades was carefully tracked. Blade No. 2 is considered the more representative base case for recurring cost since its manufacture was relatively free of such non-recurring work as tool development and process try-out. The cost of Blade No. 2 was \$307,000 (in 1981 dollars, including fee) which represents a density cost under \$12/lb. Using appropriate learning curves for a tooled production run, this projects to under \$6/lb. for the 100th blade. However, the special design constraints imposed on the Mod-1 blade, discussed earlier, represent cost drivers. Elimination of this effect could further reduce the above blade costs by a significant amount.

A reduction in rotor speed from 35 rpm to 23 rpm was incorporated in the Mod-1 wind turbine in 1980 to effect an improvement in noise level. This change was introduced mid-way in the composite blade design effort. Its effect was assessed by both Kaman and NASA, especially on blade loads, frequencies, and deflections. Margins of safety for the blade structure were positive for all cases at the higher rpm, but included a costly hand procedure for mid-span spar shell buckling reinforcement in the critical region. The reduced loads resulting from the lower rpm maintained a positive buckling margin of safety without this reinforcement.

Finally, a preliminary assessment was made of the task of shipping the two blades to Boone, although actual shipment of the blades is not within the scope of the contract. It was concluded that the use of existing truck adapters which were built and used for shipment of the Mod-1 steel blades is

feasible, with appropriate modifications for the composite blades. No difficulties are anticipated in shipping the two blades by truck from Connecticut to Boone.

For this program the Project Managers for NASA Lewis Research Center were Thomas P. Cahill and James R. Faddoul; Program Managers for Kaman were Herbert W. Gewehr and William R. Batesole.

2.0 INTRODUCTION

In the 1977 - 1978 time period, large U. S. wind turbine generators were being designed and built with metal or wood blades since the properties and manufacturing technology involved with these materials were well understood. However, the use of composites for construction of large blades was also being considered because of the significant potential advantages of this material, which include:

- Excellent fatigue properties and strength-to-weight ratio

- Nearly unlimited design flexibility in accommodating optimized taper of planform and wall thickness, twist, and natural frequency control

- High resistance to corrosion and other environmental effects, resulting in long service life

- Low notch sensitivity with slow failure propagation rate

- Low electromagnetic interference

- Low-cost potential due to adaptability of the material to highly automated production methods.

Composite construction had, at that time, been in successful use for some years in helicopter rotor blades. To assess the state of its technology for wind turbine blades, especially in the very large sizes, NASA selected Kaman in 1977 to design, manufacture, and static test a 150 ft all-composite blade. This program was accomplished successfully, as described in Reference 1; i.e., design and manufacturing methods were developed, the blade constructed, and structural testing confirmed that the analytical design methods had satisfactorily predicted the strength and dynamic characteristics of the final article. The 150 ft blade is the largest composite rotor blade ever constructed, Figure 2.

Based on the encouraging results with the 150 ft blade, NASA decided to extend the evaluation of composite blades into an operational test phase. Accordingly, NASA again contracted with Kaman, in mid-1979, to design and build two 100 ft blades to be installed and evaluated on the Mod-1 wind turbine operating in Boone, North Carolina. NASA stipulated that these blades were to directly utilize the technology developed for the 150 ft blade program; i.e., they were to be designed and manufactured using the same methods, materials, and basic structural configuration. In this program, NASA assumed responsibility for assuring compatibility of the blades with the Mod-1 system; to this end, NASA provided all design cases and interface parameters. Kaman's task was to carry out the structural design and analysis, manufacture the tooling and the blades, and conduct structural proof testing prior to delivery.

This report describes all phases of the Mod-1 blade effort. Since the program is effectively a direct follow-on to the 150 ft blade work, the report repeatedly refers to and builds upon material included in that program. Hence, this report should be read in direct conjunction with the final report of the 150 ft blade contract, Reference 1.

3.0 BLADE DESIGN

3.1 Design Concept

Stipulated from the outset of the program was the requirement that the Mod-1 composite blade would be directly interchangeable and compatible in every way with the present steel blades. NASA retained responsibility for assuring this compatibility, and was specifically charged in the contract Statement of Work with providing:

- Performance Analysis
- Aerodynamics
- Loads and Natural Frequency Requirements
- Interface Description
- Tower Clearance Limitations
- Dynamic Stability.

Many of the above parameters were defined in the contract specification. As the design work progressed, certain modifications and interpretations to the design conditions of the specification were introduced. These are discussed in this Section and in Section 4.0, and included in the Appendix.

Also stipulated initially was the basic configuration of the blade, which was required to utilize the design features of the 150 ft blade to the maximum extent. However, as the design process evolved, Kaman recommended certain changes to introduce more recent thinking in blade construction and to effect a reduction in complexity and cost. One such change, concurred in by NASA, was elimination of the trailing edge as a primary structural member. This allowed deletion of the 150 ft blade's trailing edge spar, or spline, as well as the inboard truss structure necessary to accommodate spline loads. In the Mod-1 blade, the main spar was increased in its edgewise dimension to serve as the main structural member, carrying primary loads. Thus, the afterbody reacts the airloads acting over its surface area and, because of its low relative stiffness compared with the spar, a minor share of edgewise bending loads.

Certain areas of design had not been addressed in the 150 ft blade, owing to its role as a ground test article only. Consequently, these represented new design areas for the Mod-1 blade which are discussed in this section. They include:

- Lightning protection (Section 3.6)
- Functional inboard adapter fitting (Section 3.5)
- Paint system (Section 3.8)
- Leading edge protection (Section 3.8)
- Ice detector (Section 3.7)
- Chordwise overwraps for redundant afterbody-to-spar retention (Section 3.4)

The requirement that the blades duplicate stiffness and natural frequency characteristics of the steel blades significantly influenced overall design, especially in blade thickness and the resulting planform. The final blade, Figure

3, is 97.4 ft in length with linear twist of 11° over its full length; an NACA 23xxx series airfoil is used as specified by NASA. It will be seen that the blade is comprised of three principal elements: the composite spar, Figures 4 and 5, a monolithic tubular member which transitions from a D-shape outboard to a circular cross section inboard; the composite afterbody which completes the airfoil section; and the steel adapter fitting, a flanged circular member permanently attached to the spar at the inboard end. These main elements consist of several sub-elements which are described in the following paragraphs.

3.2 Spar

The spar is the primary structural member in the Mod-1 blade design. It is a single piece monocoque tube whose nominal wall thickness of 1.0 in. is reduced locally at the tip to 0.5 in. These thicknesses refer to the corners of the D-shape portion where laminate compaction is greatest. The spar wall is locally increased, to a nominal 5.0 in. at the inboard end to accommodate the bolt group which attaches the adapter fitting. Spar weight is approximately 18,600 lbs. Its design builds directly upon the technology of the 150 ft blade spar and continues to utilize tape wound construction, a process which lends itself to low cost, high rate manufacture. Specifically, Transverse Filament Tape (TFT) is used. TFT is a commercially available product which has been employed for some years in the manufacture of less critical structures such as composite pipe, storage tanks, and covers for railcars and barges. As the name implies, TFT is a fiberglass tape in which all structural fibers are aligned across its length. When wound circumferentially with an overlap, followed by a minor amount of conventional 90° windings to provide compaction and hoop strength, very rapid laydown of predominantly spanwise fibers is accomplished.

Materials which comprise the spar laminate are as follows:

Primary Spar (Section 7.1, Step 1)

TFT: 13 courses, 17 in. wide band of 36 oz/sq. yd. E-glass roving
Hoop: 13 courses, 64 roving band of 750 yds/lb. S2-glass roving

Inboard End Reinforcement (Section 7.1, Step 2)

$\pm 45^\circ$ Broadgoods: S2-glass, 50 in. width, 24 oz/sq. yd. density
TFT: S2-glass, 70 in. width, 12 oz/sq. yd. density

Resin System

Epoxy resin: DER 332 (Dow) 80 parts by weight
Diluent: RD-2 (Ciba-Geigy) 20 parts by weight
Curing agent: Tonox 6040 (UniRoyal) 22.5 parts by weight

The reinforcement at the inboard end of the spar consists of a total of 156 courses (including $\pm 45^\circ$ broadgoods, S-2 glass TFT, and S2-glass hoop roving), which vary in length from 3 ft. to 10.3 ft. When interleaved with the 13 courses (each) of regular E-glass TFT and hoops, this produces a laminate thickness of approximately 5.0 in. having essentially isotropic properties in the region of the 18 bolts connecting the steel adapter fitting.

The basic spar laminate, made up of the 17 in. wide, 36 oz/sq. yd. E-glass TFT and hoop rovings, is essentially the same as that which was developed and characterized for the 150 ft blade. One difference is the substitution of S2-glass for the hoop rovings in place of E-glass, a change made to improve fatigue strength. The use of this basic laminate was required by NASA in order that the extensive strength characterization work performed under the 150 ft blade contract could be directly utilized for Mod-1.

Because of improvements in the winding system and tooling introduced by Kaman for the Mod-1 blades, the spar was able to be designed as a single-piece unit. The 150' spar had been built on a winding machine having a mid-span steady rest for support of the mandrel. This feature, along with the crude method employed for spar removal, necessitated that the spar be manufactured in four stages, each separately wound and cured. Four-step winding not only greatly extended the time and cost of the 150 ft spar manufacture, but also is considered to have introduced local discontinuities in the laminate that led to an early failure during the 150 ft blade's static test program. The two major tapered overlap areas that result from the four-step winding process were considered to have introduced a question of structural reliability and, hence, are not representative of a production blade design. Consequently, the Mod-1 spar was built on a new winding machine designed by Kaman to eliminate a center support and, hence, the multi-stage winding process.

As will be discussed in Section 4.0, the spar design was significantly affected by the mandate to duplicate the stiffness characteristics of the Mod-1 steel blades. Since the modulus of elasticity (E) of the composite laminate is approximately $4.0 - 6.0 \times 10^6$ psi vs 29×10^6 psi for steel, matching of the stiffness required an increase in blade spar depth in the inboard region to bring about a compensating increase in section moment of inertia. However, since weight was also a design constraint, the wall thickness of the enlarged spar had to be held to a minimum. Hence, the task became one of designing to the limits for thin shell buckling or local compression crippling under the design conditions of the specification. As a consequence of increasing the blade depth, the blade chord was also increased in order to provide a favorable airfoil thickness ratio; hence, the planform shape changed from the constant taper of the steel blade to stepped taper in which the wide chord extends nearly constant over the inboard half of the span, as shown in Figure 3.

Also influential in the selection of spar proportions was the change to eliminate a trailing edge spar, or spline, as employed in the 150 ft blade. This entailed an increase in edgewise dimension for the spar so that it occupies a higher percentage of the total chord than in the 150 ft blade.

In consideration of the criticality of spar buckling to the blade design, a special reinforcement taking the form of $\pm 45^\circ$ bias filament tape (BFT) was introduced in the preliminary spar design to thicken the critical area of spar wall. The reinforcing material was added over approximately 50 ft of span at the lower (flattest) surface only. This reinforcement was later removed from the design as a consequence of the Mod-1 rpm reduction which relieved the severity of the critical load case, the overspeed shutdown.

3.3 Afterbody

The afterbody of the blade is comprised of upper and lower panels which form a hollow aft closure, completing the airfoil shape, Figure 4. Six panels are employed, each approximately 30 ft in length, Figure 5.

The panels are joined together at the trailing edge with a simple closure wrap which is sufficient as a shear tie since the afterbody is not required to react primary edgewise beam loads. This represents a significant change from the 150 ft blade configuration, and was recommended by Kaman during the preliminary design phase. In the 150 ft blade arrangement, the trailing edge was an active structural member in reacting in-plane blade bending; hence, a trailing edge spar member, or spline, was required, along with an inboard truss structure to carry trailing edge reactions forward into the blade-to-hub attachment.

The three upper and lower panel sets vary in thickness; i.e., inboard 3.0 in., center 2.0 in, and outboard 1.0 in. They are of sandwich construction, made up of inner and outer skins with a paper honeycomb core. Specifically, the materials are:

Outer Skin: 2 plies, style 1583 E-glass prepreg; thickness - .018in./ply (outer edges reinforced to 8 plies)

Inner Skin: 1 ply, same material

Core: Phenolic impregnated kraft paper, 3/8 in. cell honeycomb; density - 2.3 lb/cu. ft.

Materials and the general design of the panels are identical with that of the 150 ft blade. Therefore, the structural sample tests and material characterization completed in that program were used directly in the Mod-1 design.

Weight of panel sets:

<u>PANEL SET</u>	<u>WEIGHT (LBS)</u>
Inboard, Upper and Lower	501
Center, Upper and Lower	364
Outboard, Upper and Lower	169
TOTAL, all panels	<u>1,034 lbs</u>

Afterbody attachment - The panels attach to the spar by means of a lap joint of the outer skin, and by use of a built-up T-clip at the inner skin, Figure 4. This is similar in concept to the 150 ft blade arrangement; however, a considerable development effort was required in devising the T-clip detail design to overcome difficulties experienced in the 150 ft blade program in ensuring a high integrity bond attachment. The challenge of this design lies in the relative inaccessibility of the T-clip location for manufacture. Hence, a configuration was evolved which enabled the T-clip to be built up in two

L-shape legs, each installed as wet layups. During this development, it also became apparent that the early selected adhesive was excessively brittle and, hence, vulnerable to cracking under installation clamping loads and tensile peeling loads which would be exerted by the panels during operation. A laboratory tensile test program was implemented in devising the final choices of adhesive, radius of fillet curvature, and adhesive filler material. In all, fourteen different combinations were tested.

The final buildup of the T-clip utilized single ply E-glass fabric wet layups with a resin system consisting of Epon 828 epoxy resin (75 parts), Versamid 125 polyamide curing agent added for resin toughness (25 parts), and DTA amine curing agent/accelerator (4 parts). HYSOL EA913 epoxy adhesive was used to fill the void formed by the fillet radii. Bonding of the T-clip to the panel utilized EA913. Syntactic foam was injected into the void between the panel and spar; the role of this material is to react shear loading at the joint. Reliabond 371/6 foam was selected.

The lap joint of the panels' outer skin to spar surface is a straightforward attachment bond using EA913 adhesive, and is identical to the 150 ft blade design.

3.4 Overwraps, Closures

Included here are the trailing edge wrap, the five chordwise overwraps, and the afterbody's inboard end closure, Figure 5. These are discussed briefly as follows:

Trailing edge wrap - As noted earlier, the Mod-1 blade trailing edge represents a simple closure in place of the structural spline incorporated in the 150 ft blade. The rear panel edges are bonded together with HYSOL EA913, followed by covering with a three-ply wet laminate of E-glass Style 1581 fabric cured with the same epoxy resin system developed for the T-clip. Width of the fabric plies is staggered from 1 in. to 2 in. on the upper and lower panels. Note that the above cloth and resin is used for all overwraps and closures discussed in the following paragraphs.

Chordwise overwraps - NASA chose to add a series of five chordwise bands extending completely around the airfoil periphery. These were introduced as an added structural retention of the afterbody to the spar, a redundant load path in case of any long term deterioration of the primary attachment of the panels to the spar. The bands are designed as a wet laminate of ten plies of cloth, staggered so as to comprise a 36-in. wide laminated wrap. Two of the bands are located at panel junctions, thus serving as the panel-to-panel splicing means.

Inboard end closure - This panel serves to seal off the hollow afterbody and to provide a structural diagonal member to carry forward in-plane bending reactions from the afterbody. The 1.0 in. thick closure panel is constructed as a prepreg cloth and paper honeycomb sandwich identical to

the afterbody panels themselves. It is joined to the inboard panel edges by direct bonding and employs seven wet lay-up plies of corner reinforcement. Consideration was given to adding a circular manhole, with cover, in the center of the inboard closure panel to permit entry into the hollow afterbody for field inspection, repair, etc. Although not incorporated due to funding constraints, this feature is considered to be a useful addition to future blades.

3.5 Adapter Fitting and Attachment Hardware

A large, cylindrical steel fitting is permanently installed at the inboard spar end to serve as the structural interface with the rotor hub of the wind turbine, Figure 6. It is flanged at its inboard end with the provision of 56 holes for the blade-to-hub attachment bolts. The fitting is joined to the spar by eighteen bolts arranged in two circumferential rows. The fitting and its attaching hardware are each discussed, as follows:

Adapter fitting - Design and material selection for the fitting itself was a new task for the Mod-1 program. The 150 ft blade utilized a steel dummy member intended only for welded attachment to the test rig. The final Mod-1 fitting is circular in cross section with approximately 72-in. diameter and 41-in. length. Its inboard flange, for the blade-to-hub bolt attachment, differs considerably from that of the Mod-1 steel blade in that an internally oriented flange is used. This results from the inboard end of the blade being larger in diameter than the steel blade, so that a steep conical neck-down would have been required to accommodate an external flange such as that of the steel blade. A layout study ascertained that sufficient room exists within the fitting to permit a hydraulic bolt tensioner to be used during the torquing of the fifty-six 1-5/16 in. diameter bolts when the blade is assembled to the hub at the wind turbine site.

The adapter is built up of three rings, welded together and machined all over. The inboard ring is a forging incorporating the flange, while the other rings are rolled steel plate stock of 1.25 and 1.5 in. thickness. HY80 alloy steel (U.S. Steel) was selected by Kaman, in consultation with NASA, after a considerable search for a satisfactory weldable alloy. HY80 retains its notch toughness and ductility after welding and without stress relief, a process which would be difficult in such a heavy wall part. It is widely used for applications subject to dynamic loading such as submarine pressure hulls, shock test platforms and rocket engine test stands.

The weight of the adapter fitting is 4,814 pounds.

Adapter hardware - The adapter fitting attaches to the spar by means of eighteen bolts arranged in two bolt circles set 13.0 in. apart. Design of this critical connection is based directly on that of the 150 ft blade which utilized a similar single-shear bolt connection. Each bolt set,

Figure 6, consists of a 3.0-in. diameter rod, threaded at both ends, two nut/washer pairs, and a specially sized and tapered bushing of 4.4-in. diameter. The bushing length is carefully controlled relative to the composite thickness so that, when torqued down, the washer and bushing will be heavily clamped to the spotfaced surface in the adapter fitting, but will only lightly clamp the composite wall. Thus, the bushing is effectively made to act as a rigid stud attached to the adapter fitting. Under blade centrifugal and bending loads, the eccentric single-shear joint deflects. However, the slight taper machined in the bushing wall will, under deflection, provide for an even distribution of bearing stress along the full length of the socket in the composite. This concept of anticipated deflection is frequently employed in helicopter rotor system design, and was successfully used and tested for the similar bolts of the 150 ft blade. Each of the threaded rods (bolts) has a full length axial bore of 0.5-in. diameter, so that an internal length gage may be used during torquing to give a direct measurement of bolt stretch.

All items of the hardware set are machined from 4340 steel, and are cadmium-plated. Total weight of the eighteen sets is 1,122 pounds. The bolts which will be used at the connection of the blade to the Mod-1 hub will differ only in length from the bolts used for the steel blade; 1.37 in. additional length is required.

3.6 Lightning Protection System

The design and development process used by Kaman to provide a lightning protection system will be described in Section 6.0. Therefore, only a description of the resulting system is provided here.

The system, Figure 7, consists of three basic elements: an aluminum tip cap; a single spanwise conductor located at the trailing edge; a metallic shield covering the area of the spar occupied by the adapter fitting.

The tip cap is a 6061 aluminum weldment, which incorporates a 6.0 in. "skirt" on the outer surface of the blade. To this is connected the fullspan conductor strap which is attached along the underside of the blade at the trailing edge. The strap is a flattened copper braided tube of 48,000 circular mils cross sectional area, molded into a urethane thermoplastic sheath, Goodrich Tuftane 800. This is bonded to the trailing edge using EPON 828 Epoxy Resin adhesive, and covered with a two-ply glass fabric layup. The purpose of encasing the braid in thermoplastic material is to provide a resilient attachment so as to preclude load pick-up by the strap during blade bending deflection. A path to ground is provided by connection of the strap to an aluminum lug at one of the adapter fitting attachment bolts.

At the inboard end of the blade, a metal shield is provided on the outside of the spar in the form of a single 42-inch wide wrap of Hexcel Thorstrand[®], a + 90° fiberglass fabric whose fibers are aluminized. This shield extends to station 88.4 which is approximately 7 in. beyond the extremity of the adapter fitting inside the spar.

The tip cap includes two 0.25-in. diameter drilled holes which serve to vent the spar and afterbody cavities to atmospheric pressure and to provide drains for condensed moisture.

3.7 Ice Detection System

The Mod-1 metal blades incorporate an ice detector system which is intended to sense any significant level of ice buildup and shut down the wind turbine.

NASA requested that an identical detector be installed in one of the Mod-1 composite blades and located at approximately the same spanwise and edgewise point.

The detector unit is the Rosemount Model 871 FA aircraft ice detector. This self-contained unit senses ice buildup on a vibrating probe which extends from the surface of the blade. Changes in probe frequency due to ice accumulation trigger a switch mechanism for shutdown.

The unit is located on the lower surface of one blade, at blade station 337, 66 inches from the trailing edge. It is mounted on an adapter plate bolted to the reinforced edges of a 5.08-in. diameter hole in the afterbody panel. A multiple-wire electrical lead is routed on the blade outer surface directly back to the trailing edge and from there follows the lightning protection ground strap to the inboard end of the blade where it passes into the adapter fitting through the bore of one of the adapter-to-spar bolts.

3.8 Paint System

A paint system is applied to the exterior surface of the blade for protection against the elements. Of particular interest are ultra-violet exposure, moisture, fungus growth, and sand/water abrasion.

The selected system is based on experience in helicopter composite blade protection and consists of one coat MIL-P-23377 epoxy primer and a mist coat/full coat MIL-C-83286 urethane in white.

Special protection for the leading edge is provided over the outboard one-third of the blade by a build-up of the urethane top coat to 8 - 10 mils thickness. This heavier layer is feathered out at approximately the 20% chord. Kaman's experience in the development of leading edge protection for Army helicopter blades has shown that a resilient layer such as this is superior to the use of hard materials in resisting the effects of sand and water impingement.

Blade markings are provided, using MIL-L-81352 black acrylic. Included are blade serial numbers, spanwise station markers, tip identification, CG location, and blade weight, and handling fixture locations. Tip striping is provided using orange urethane.

Little knowledge exists on which to predict the longevity of paint systems for large wind turbine blades; the frequency of paint refurbishment will have to be developed from service experience.

Consideration was given to the use of an anti-static paint layer to reduce static charge build-up and its possible discharge spark damage to the composite skins and outer paint system. Some reduction of microwave reflectivity might also result from use of the carbon-charged paint, a possible benefit in terms of television interference. NASA elected to omit this type of paint and to observe whether static build-up does cause any ill effects in long term service, as part of the experimental Mod-1 program.

3.9 Instrumentation

A permanent instrumentation system is a requirement for operation of the blades on the Mod-1 wind turbine. This system takes the form of strain gage bending bridges installed at three spanwise stations. Pending a NASA decision on continuation of Mod-1 wind turbine operation, this system has been designed but not yet installed on the blades.

Because of a concern for the reliability of externally-mounted strain gages, NASA requested that all gages and attendant wiring be installed inside the spars of the composite blades. The design provides full (4 active arm) bending bridges at stations 50.5, 375.0, and 800.0. The gages will be located at the following four locations around the internal periphery of the spar: leading edge, trailing edge (center of rear spar face), top, and bottom (at quarter-chord point). Redundancy is provided by adding a second independent bridge at each location, complete with its own wiring system to the inboard end of the blade. Special cloth patches were built into the spar wall during winding, at the gage locations, to provide a satisfactory surface for gage attachment. Each bridge is wired with ribbon cable to a small terminal strip. From the strips, four conductor (22 gage) shielded cable is routed along the aft lower corner of the spar to the inboard end of the blade.

To ensure durability of the system, the design uses moisture-proof¹ coatings on the gages, terminal strips, and spanwise cabling.

4.0 STRUCTURAL ANALYSIS

4.1 Design Requirements

The Mod-1 composite blades were designed to operate for thirty years in all environments through a wide range of temperatures (-30°F to +120°F). The structural arrangement and material properties used in the design and analysis of the Mod-1 blades are those developed for NASA during the 150' blade program, with additional material properties data developed during this Mod-1 program.

The following design criteria have been utilized to ensure the life and static strength of the blade:

Static Strength

1. All parts must withstand 1.15 x design limit load without permanent set.
2. All parts must withstand 1.5 x design limit load without fracture.

Fatigue Strength

1. To assure a thirty year life, no component's fatigue loading is to exceed component endurance limit.

Buckling Stability

1. All parts must be shown analytically to withstand 1.5 x 1.5 x design limit load with no buckling. The additional 1.5 factor here considers possible optimism of analytically determined buckling stress.

Critical Design Condition Summary - The Mod-1 composite blades were designed to withstand a wide variety of environmental and loading conditions. These design loading conditions, listed in full in the Appendix, include:

1. 35 MPH Normal Operation - This is the high cycle fatigue design condition for the Mod-1 blades.
2. 120 MPH Downgust - This design condition produces the minimum margin of safety for spar upper (cambered) surface buckling at about blade mid-span.
3. Emergency Feather and Overspeed of 38.9 RPM (34.7 RPM Normal) -

This condition produces minimum Margins of Safety (M.S.) for spar lower surface buckling, the blade root end, the bolted connection, the steel adapter, and the outboard blade area. This design condition was originally responsible for the inclusion of mid-span spar wall reinforcement as a buckling stabilizer. NASA later replaced this design condition with a less critical rapid stop case at a reduced overspeed of 27.3 RPM (23.1 RPM normal). This reduction in ultimate blade loading eliminated the need for mid-span spar wall reinforcement. Subsequent to NASA's revision of critical load cases, the spar reinforcement was removed from the blade design. See the specification amendment in the Appendix.

4. Rapid Stop at Overspeed of 27.3 RPM (23.1 RPM Normal) -
This lower speed operational shutdown case was issued by NASA to replace the 38.9 RPM overspeed emergency feather condition, and consequently became the critical design case for spar buckling and afterbody compression.
5. 150 MPH Wind, Flat Plate Drag on Blade Afterbody - This design condition produces the minimum M.S. for the afterbody-to-spar T-clip connection.

4.2 Material Allowables

The majority of the strength and stiffness properties used for the materials employed in the Mod-1 blade were determined previously during the 150' blade program. The 150' blade program final report, Reference 1, records the testing done and the property and strength values determined from that testing, and used during the Mod-1 blade program. Material properties which were determined specifically for and during the Mod-1 program are discussed below.

Material static strength properties for the bolt bearing region of the built-up spar root end were required to determine bolt spacing, interaction, and ultimate strength of the spar-adapter interface. Scale coupon testing was undertaken to determine edge and end distance requirements for optimum composite strength. This testing showed that net bearing loads in excess of 30 ksi can be maintained at 120°F wet test condition by the Mod-1 root end spar materials. The fatigue strength of this root connection scheme had been investigated during the 150' program; however, testing was suspended when adequate strength for that program had been demonstrated. During the Mod-1 program this 1/4 scale fatigue testing was continued to completion. The results of this testing indicate that a value of 20% of the Mod-1 root laminate net bearing strength is a safe composite net bearing endurance limit for low R values ($=0.1$). See the S-N curve at the end of this section.

The buckling stability of the outboard spar of the Mod-1 blade was thoroughly investigated by both analytical and test methods during the Mod-1 program. Four methods were used to determine the critical shell load; these were simple orthotropic plate buckling, intermediate length orthotropic cylinder buckling, full section NASTRAN buckling analysis, and a stringent full scale prototype blade buckling test. The prototype buckling test was inconclusive, as the shell buckling load was never reached; however, adequate buckling strength for the spar was demonstrated. The analytical methods employed to pre-determine the critical buckling load all underestimated the critical load, and therefore are safe, if not economical, measures of buckling criticality.

Another area which received special development testing attention was the region of afterbody-to-spar attachment via the T-clips. The T-clip attachment scheme had been developed during the 150' program; however, cost-reducing manufacturing and fabrication changes necessitated development of an alternate co-curing laminating resin and fabrication procedure. This test program's desire was to ensure that strength levels attained during the 150' program were maintained with the less expensive Mod-1 procedures. This program was

highly successful, with a number of fabrication procedures and resin combinations showing static strength in excess of the required 565 lb. per lineal inch.

Metallic component allowables were developed from manufacturers' literature and limited test data. The HY-80 welded adapter static strength allowables were verified by small specimen, full thickness tensile testing of butt welded samples. The fatigue endurance limit for the welded, machined, shot peened steel adapter was determined from limited high load, low cycle test data of HY-130 steel with transverse butt weld and known defects, reinforcement removed, as shown on the S-N curve at the end of this section. The data points on the S-N curve are from a November 1969 report by the Civil Engineering Department of the University of Illinois for low cycle fatigue of butt weldments of HY-130 (T) and HY-100 (T) steel. The S-N curve shape that was passed through the test points was from report NACA TN 3866 for SAE 4130 steel sheet with ultimate tensile strength of 130 ksi, a peak tensile notch factor of 4.0, mean stress of zero and $R = -1.0$. This procedure determined a welded HY-80 fatigue endurance limit at $R = 0$ of ± 15 ksi. Connection hardware allowables were obtained from MIL-Handbook V and manufacturers' data.

A table of allowables follows the S-N curves at the end of this Section 4.2.

- △ Normalized failure points (to zero steady)
 - ⊙ 3-sigma reduced projected failure points
- $F_{BRU} = 40$ ksi average bearing stress at failure

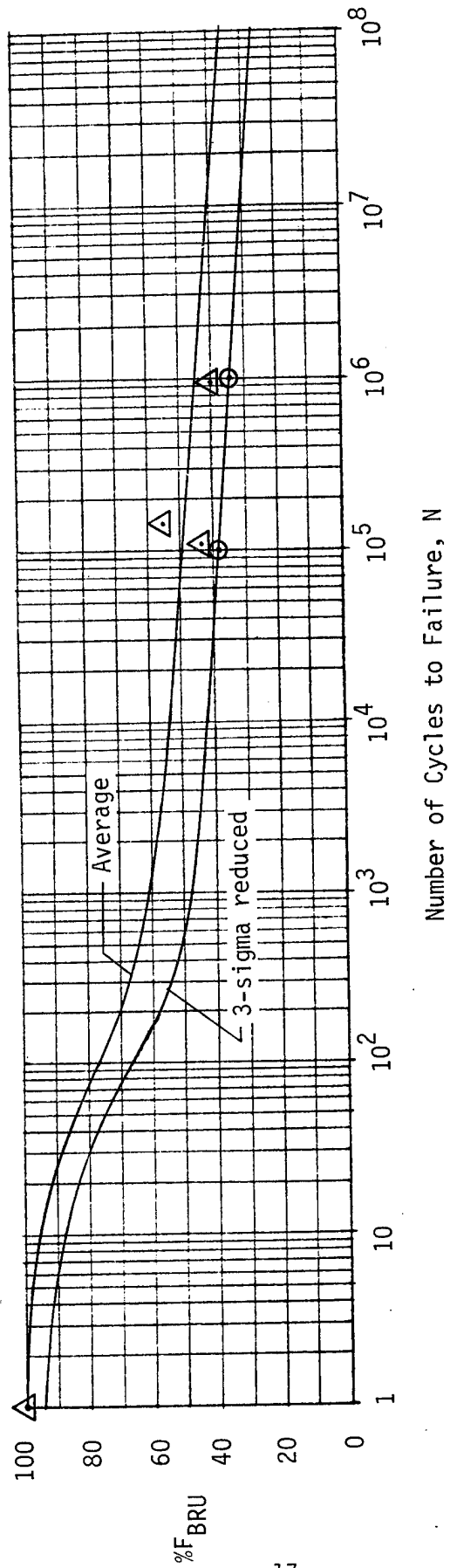

S-N Curve; Composite Root End Bolt Bearing Fatigue
(Room temperature, dry)

⊙ HY-130 data, University of Illinois

Curve shape: 4130 steel (NACA TN 3866) with
 $F_{TU} = 130$ ksi; $K_T = 4.0$; Mean stress = 0; $R = -1.0$

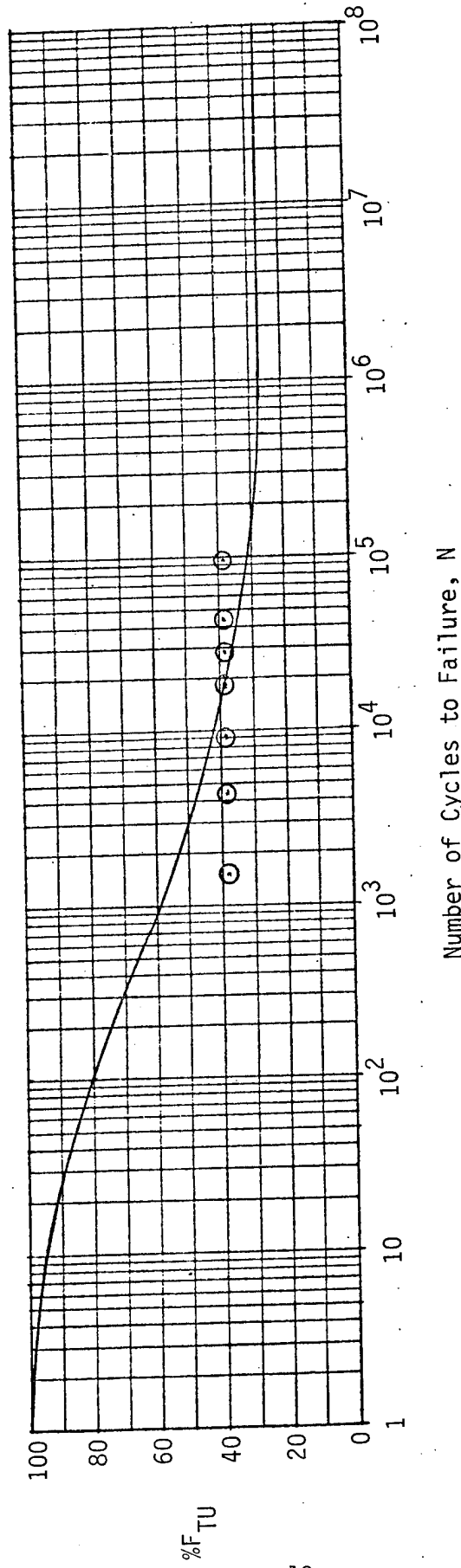

S-N Curve; Steel Adapter Fitting Fatigue

MATERIAL STRENGTH ALLOWABLES

1. Reinforced TFT (quasi-isotropic S-glass and E-glass epoxy laminate)

Ultimate bearing stress, F_{BRU} (160°F, wet) = 28.8 ksi

Ultimate bearing stress, F_{BRU} (room temp., dry) = 40.0 ksi

Endurance limit stress, F_{END} (R=-1; room temp., dry) = ±10.4 ksi

2. Outboard TFT (0° - 90° E-glass epoxy laminate)

	Orientation of Fibers	Ultimate Stress, ksi	
		Room temp. dry	160°F wet
Tension	0°	53.2	52.7
Tension	90°	1.3	1.3
Compression	0°	63.5	44.2
Compression	90°	7.99	7.53
In-plane Shear	0°-90°	4.61	3.46
Interlaminar Shear	0°	6.73	3.31
Endurance, F_{END}	0°	9±7	

3. Afterbody Skins (181 woven S-glass epoxy cloth)

Tension	0°	58.2	32.5
Tension	90°	57.8	31.1
Compression	0°	56.7	19.7
Compression	90°	49.9	17.4
In-plane Shear	0°-90°	13.9	9.3 (160°F dry)
Endurance, F_{END} (R=-1)	0°	±4.0	

4. Steel Adapter (HY-80 material, forged and rolled plate)

Tension Ultimate, F_{TU} = 110 ksi

Tension Yield, F_{TY} = 80 ksi

Endurance, F_{END} (R=-1) = ±15 ksi (welded, machined, shot peened)

5. Spar-to-Adapter Studs (4340 Steel)

Tension Ultimate, F_{TU} = 150 ksi

Tension Yield, F_{TY} = 132 ksi

Shear Ultimate, F_{SU} = 90 ksi

Bearing Ultimate, F_{BRU} = 219 ksi

Bearing Yield, F_{BRY} = 189 ksi

Endurance, F_{END} (R=-1) = ±26 ksi

4.3 Substantiation Approach

Substantiation of the static strength and fatigue life of the Mod-1 blade was accomplished by a variety of techniques. This section relates, on an area by area basis, the analytical procedures used in the evaluation of the Mod-1 blade.

Spar Root End - The root end of the Mod-1 blade was designed using finite element (F.E.) grids and conventional free-body analysis. The F.E. model used for determining bolt load sharing and steel adapter stress was an axisymmetric model. This model included the wind turbine hub pitch bearing, steel adapter and pitch barrel connection bolts, spar-adapter shear connector bolts, and the inboard reinforced TFT blade shell. The F.E. model produced the loads and stresses necessary to compare with component allowables and determine part criticality. The results of this analysis, as reflected in component minimum margins of safety, are tabulated in the design margin of safety summary, Section 4.4.

Spar Outboard - The spar outboard section of the Mod-1 blade was analyzed using primarily two Kaman in-house computer programs. These programs are SHELL-D and CMAB, and have proven excellent design and analytical tools for over ten years. CMAB determines gross laminate properties and orientations from the orthotropic input ply-by-ply and performs a ply-by-ply stress analysis using SHELL-D determined laminate running loads based on plane section assumptions for general, multiple cell tubular structure, given applied section loads and cross-sectional elemental make-up. The results of this analysis are tabulated in the design margin of safety summary.

The outboard spar theoretical buckling allowable load was determined by three different techniques, all of which were conservative based on prototype buckling tests, with the ultimate applied stress determined by SHELL-D using NASA supplied blade loadings.

Blade Afterbody - The Mod-1 blade afterbody incorporates three sets of upper and lower sandwich panels. These panels are cured to final blade contour and assembled to the spar through the use of T-clips and outer skin-to-spar lap shear bond. The loading on the various panel sets and their spar joint connections was determined by SHELL-D and frame analyses for the blade bending and afterbody panel normal airload cases, respectively. The panel and connection loads were compared to the 150' blade connection allowables which were verified by the Mod-1 T-clip development testing. The inboard planform termination of the afterbody panels was investigated to determine the geometry which would minimize the T-clip and lap shear bond loads. This 2-D finite element investigation showed that the high peaking of the indicated loads at the inboard termination could be greatly reduced by a triangular planform truncation over that of a rectangular termination. This change in the inboard afterbody planform geometry is incorporated in the final prototype blades.

Adapter and Hardware - The steel inboard adapter was analyzed by the use of AX3A, an axisymmetric finite element program. The capabilities of this program are static analysis of any body of revolution for general loadings.

AX3A provided detailed stress distributions, both circumferential and through the thickness, at the critical structural locations and the circumferential welds, for the static and fatigue design conditions. These detailed load distributions were used in conjunction with the material allowables to determine margins of safety. AX3A also provided the adapter-to-blade bolt load distribution for use in the hardware analysis. The connection hardware criticality was determined by conventional equilibrium assumptions with material allowables as presented in Section 4.2.

The HY-80 steel adapter fitting presented some problems during fabrication. The adapter consists of welding together three pieces, which are an inboard forged ring, a conical center section rolled from 1.25 in. thick plate, and an outboard cylindrical section rolled from 1.5 in. thick plate. The quality of the weld is highly dependent on the procedure, and in fact the first adapter was rewelded at least twice before the procedure was refined and it passed inspection. The difficulty in rolling the plates produced a slight out-of-round and mismatch between sections, which required extra material to be removed in clean-up to meet dimensional requirements. The dimensional clean-up did not remove all of the decarburized layer, requiring local hand grinding to accomplish this. The material thickness was therefore slightly under drawing tolerance locally, which had an insignificant structural impact. The parts were accepted, with additional safety expected from the reduced loads at the lower rpm. The parts underwent Xray after welding, then were machined all over, hand-ground locally, and shotpeened in the critical weld regions.

Subsequent to final adapter design, fabrication, inspection and assembly, a further fatigue life analysis was performed using linear elastic fracture mechanics. This analysis shows that if certain surface weld flaws exist in the critical circumferential location, the adapter life could be significantly reduced; however, the parts did not undergo re-Xray after surface machining and shotpeening. Kaman has recommended to NASA that the extent and location of weld flaws, if any, be determined by an additional 3-D radiographic inspection, and subsequent adapter life re-evaluation be undertaken. If a flaw exists, of such a size and location as to adversely affect life, it will be subject to removal by local surface grinding.

Overwraps and Closures - The criticality of the overwraps and closures was determined using allowables developed for the 150' blade and conventional equilibrium load assumptions.

Deflections and Section Properties - SHELL-D was used to determine blade section properties from stiffness data obtained from small scale TFT test specimens manufactured during the 150' blade program. Newmark's Tabular Method was used for theoretical blade deflections.

4.4 Analysis

The detailed structural analysis of the Mod-1 composite blades prior to fabrication has been previously submitted to NASA Lewis Research Center and

accepted, Reference 2. Using the methods of Reference 2 and the load conditions and approach described herein, the following table presents the minimum margins of safety calculated for the as-produced geometry and characteristics of the finished blades. Refer to Section 4.1 for further description of the critical design loading conditions.

MINIMUM MARGINS OF SAFETY

STRUCTURAL ITEM	LOADING CONDITION	FAILURE MODE	M.S./LIFE	COMMENT
INBOARD COMPOSITE BOLT HOLE REGION	CONDITION ③ (38.9 RPM EMERGENCY FEATHER)	COMPOSITE NET TENSILE AT HOLE EDGE	0.24	TENSILE ULTIMATE
	CONDITION ① (35 MPH WIND NORMAL OPERATION)	BEARING FATIGUE FAILURE	30 YR.	FATIGUE
STEEL ADAPTER PARENT MATERIAL	CONDITION ③	BOLT HOLE LIP BENDING	0.45	TENSILE YIELD
	CONDITION ①	LIP BENDING FATIGUE	30 YR.	FATIGUE
STEEL ADAPTER WELD MATERIAL	CONDITION ③	BENDING TENSION	0.89	TENSILE ULTIMATE
	CONDITION ①	BENDING FATIGUE	5-30 YR.	FATIGUE
CONNECTION HARDWARE ADAPTER/BLADE STUD	CONDITION ③	BENDING TENSION	0.064	TENSILE ULTIMATE
	CONDITION ①	BENDING FATIGUE	30 YR.	FATIGUE
PITCH BARREL CONNECTION BOLTS	CONDITION ③	AXIAL TENSION	0.32	TENSILE ULTIMATE
	CONDITION ①	TENSION FATIGUE	30 YR.	FATIGUE
BLADE SPAR	CONDITION ③	AXIAL COMPRESSION	0.70	COMPRESSION ULTIMATE
	CONDITION ④ (27.3 RPM RAPID PITCH)	BUCKLING	0.17	ON 2.25 x LIMIT LOAD = ULTIMATE LOAD
	CONDITION ①	AXIAL FATIGUE	30 YR.	FATIGUE
BLADE AFTERBODY	CONDITION ④	AXIAL COMPRESSION	0.32	COMPRESSION ULTIMATE
	CONDITION ③	PANEL BUCKLING	0.08	ON 2.25 x LIMIT LOAD = ULTIMATE LOAD
	CONDITION ①	AXIAL FATIGUE	30 YR.	FATIGUE
AFTERBODY TO SPAR ATTACHMENT	CONDITION ⑤ (150 MPH WIND, FLAT PLATE DRAG ON AFTERBODY)	T - CLIP COMPRESSION	0.15	COMPRESSION ULTIMATE
	CONDITION ⑤	T - CLIP TENSION	0.57	TENSILE ULTIMATE

5.0 STRUCTURAL TESTING

As noted earlier, the design of the Mod-1 composite blades is based upon the results of the extensive testing carried on in the 150 ft blade program. That testing included material characterization of TFT laminates both for static and fatigue properties, as well as quarter-scale fatigue testing of the adapter-to-spar bolt attachment. A full scale static bending test was also conducted on the 150 ft blade spar to substantiate spar buckling strength.

As the Mod-1 composite blade design progressed, certain testing was proposed by Kaman, and approved by NASA, to supplement that done for the 150 ft blade. These tests were: full-scale buckling test to failure of a Mod-1 test spar; additional static coupon tests of TFT laminate; and additional fatigue testing of the adapter-to-spar bolt attachment. All of this testing was accomplished and is described in the following paragraphs.

5.1 Spar Buckling

During the 150 ft blade program, two full scale flatwise bending tests were conducted. The first, in which the blade was mounted as a full-span cantilever beam experienced failure at about 9% above design limit load. The failure was found to have as its origin one of several flaws found to be present in the inboard half of the spar. These flaws, evident on the outer surface of the blade, were later determined to be a kinking of the laminate, which severely compromises local buckling or crippling stability of the laminate wall. Subsequent analysis of the causes for these flaws by both NASA and Kaman led to the conclusion that spar winding improvements to be used in the Mod-1 spars should eliminate the condition. This was later borne out; the Mod-1 spars are free of any of the flaws seen in the 150 ft spar. A second spar buckling test had been conducted on the outboard 100 ft of the 150 ft spar, which had remained intact after the first test. Because the root section of the blade with its steel adapter could no longer be used, a simplified set-up was devised for the second test in which the inboard end was held by dead weights and an up-load was applied hydraulically to the tip. This test was carried out without evidence of buckling at loads of 1.5 to 2.8 times design limit load. Subsequently, Kaman static tested another TFT spar, that of the 40 kW wind turbine developed by Kaman for DOE. Again, excellent results were seen, indicating that the knockdown factors on buckling which had been applied in designing the Mod-1 spar may have been overly conservative.

Based on the above background experience, a decision was made to conduct a full scale static test, to failure if possible, of the Mod-1 spar design. A complete spar, built as a tool try-out article, was used for this test. This spar contained the added buckling reinforcement (BFT) material on the bottom surface in the mid-span area, as discussed in paragraph 3.2.

The Mod-1 spar test utilized the simplified test set-up, described above for the second 150 ft blade test. A 60 ft section of the spar was loaded as a cantilever beam by a single tip load. Test loading was carried to the full tip deflection limits of the test apparatus without experiencing a failure, Figure 8.

The large margins of safety based on the results of this test led to a tentative conclusion that the BFT material might be eliminated for the final spar design. To provide additional support for such a change, the spar was turned over and retested, thus assessing buckling capability of a spar wall in compression without BFT reinforcement. Again, no failure could be achieved within test setup limits. Although such a case is not entirely representative of the actual spar with BFT removed, the test results continued to support the deletion of BFT reinforcement.

5.2 Root End Laminate Characterization

The detail design of the inboard portion of the Mod-1 spar, at the spar-to-adapter bolt connection, defines a pattern of interleaved layers of differing characteristics aimed at achieving essentially isotropic structural properties. In addition to the TFT/hoop layers which are consistent throughout the spar, + 45° bias cloth and lightweight spanwise unidirectional layers are locally introduced as described in Section 3.2.

As the structural analysis of the design progressed, it was felt that the 150 ft blade program had provided insufficient material characterization background upon which to base stress allowables for this area of the spar. Consequently, Kaman recommended that additional material testing be introduced. This was accomplished in the form of static coupon tests, discussed below, and added fatigue testing described in the next section.

For the static characterization, 24 tensile specimens were prepared, incorporating a 14 ply representation of the specially reinforced inboard end of the spar and 0.5-in. diameter bolts. The dimensional proportions of the rectangular coupons were chosen so as to produce failures in bearing (6 specimens), shear tear-out (6 specimens), and tension (6 specimens). The remaining 6 specimens were dimensioned to reproduce the spar's actual proportions of bolt spacing and edge distance. Half the specimens were tested under room temperature/dry conditions, half under hot (130°F)/wet conditions. Loads were applied through the bolts at each end of the specimen until tensile or shear failure was experienced or 2% elongation of the bolt holes occurred.

Average stress levels obtained for each coupon configuration were:

<u>TEST PURPOSE</u>	<u>AVERAGE STRESS LOADING</u> (LBS/SQ. IN.)	
	<u>R.T./DRY</u>	<u>HOT/WET</u>
Net Tension	44,100	36,100
Bearing	49,600	37,460
Shear-out	33,780	19,820
Scale Failure Mode	51,060	32,880

The significance of the failure stress levels to the blade's structural analysis is discussed in Section 4.0.

5.3 Quarter-scale Root End (Fatigue)

As discussed above, additional information on fatigue properties of the root end laminate was desired for analytical substantiation of the Mod-1 spar. The 150 ft blade program had included laboratory fatigue testing of four quarter-scale specimens of the root area laminate. These specimens had been constructed by sectioning a specially wound sample incorporating the mixed property laminations of the built-up inboard end of the spar. Tension-tension fatigue testing of each sample had been accomplished at differing load levels carried to 10×10^6 cycles without failure, at which point the testing was terminated.

In order to obtain more definitive fatigue strength information for use in the Mod-1 analysis, it was proposed that the previous testing be resumed and carried to failure in order to more fully define a root end laminate S-N curve. Accordingly, testing was carried out at increased load levels on all four samples, loaded in a series arrangement. When no failures were encountered by nearly 800,000 cycles, the testing in the series arrangement was discontinued. Specimens 1 and 2 were then individually tested at still higher loading until the failures noted below were experienced.

The samples take the form of rectangular tension bars, 5.0 in. wide and 38.0 in. in length, necked down in thickness to 0.392 in. in the center section. Each end is built up to 0.90 in. thickness with a 1.25-in. diameter bolt, through which the specimens were loaded in a fatigue test machine. Although the 150 ft blade laminate, represented by the specimens, differs slightly from the root end laminate of the Mod-1 spar, it is considered sufficiently representative of the family of laminates consisting of S-glass and E-glass lamina layered in differing orientations to achieve nearly isotropic properties.

The S-N curve, constructed from the test results below, and its significance to the analysis of the Mod-1 spar are treated in Section 4.0.

<u>Specimen Number</u>	<u>Tension- Tension Loading (Lbs.)</u>	<u>Millions of Cycles</u>		<u>Failure</u>
		<u>150 Ft Blade Program</u>	<u>Mod-1 Blade Program</u>	
1	5,200 ± 2,360	10		
	12,700 ± 9,790		0.787	
	17,000 ± 13,000		0.056	Laminate failure Note 1
2	12,723 ± 6,280	10		
	12,700 ± 9,790		0.787	
	13,500 ± 10,400		0.789	Equipment failure Note 2
3	9,038 ± 4,688	10		
	12,700 ± 9,790		0.787	Terminated, no failure
4	9,038 ± 4,688	10		
	12,700 ± 9,790		0.787	Terminated, no failure

NOTE 1: At 56,000 cycles, two adjacent delaminations occurred at one end in the necked down section.

NOTE 2: At 0.789×10^6 cycles, failure of a test linkage bolt occurred. Some permanent elongation of the specimen's bolt holes had been noted from the 0.40×10^6 cycle point.

6.0 LIGHTNING PROTECTION

The need for lightning hazard accommodation in the Mod-1 blades represented a new requirement which had not been addressed in the 150 ft blade. The contract specification stipulated that there be provided, "...a conductive path to ground in the event of repeated lightning strikes". No stroke amperage level was defined for design; however, based on subsequent discussions with lightning design consultants and NASA, it was agreed to utilize a lightning model, Figure 8, which peaks to 200,000 amperes current. Although such a stroke severity is extremely infrequent in natural occurrence, this was considered to be a desirable design goal for use as a starting point in the development of an arresting system.

Other considerations were included in the task of developing the system, some of which are listed by NASA in a technical paper on the subject, Reference 3. This describes the ideal lightning protection system as:

- "(1) Capable of dissipating the energy imparted by lightning without deleterious effects to personnel, structure, or instrumentation.
- (2) Low in installation and maintenance costs.
- (3) Compatible with wind turbine rotor blade manufacturing process.
- (4) Capable of withstanding repeated lightning strikes.
- (5) Easily field-repaired.
- (6) Noninterfering with television reception."

The all-fiberglass composite construction of the Mod-1 blade raised the initial question of whether a lightning arresting system is needed at all. However, experience in the helicopter industry and the general lightning field suggests that the presence of long hollow cavities such as the spar and the afterbody interiors, might, in fact, focus lightning streamers in the long air columns even without metal parts inside. Such air columns become preferential ionized paths for a lightning return stroke which can penetrate the spar wall or afterbody and cause explosive destruction of the blade. Subsequent testing, described below, substantiated this point. Therefore, it was concluded that lightning protection is needed.

Of the above listed design considerations, item (6) is especially challenging in a composite blade. Such blades possess an advantage over metal blades in their inherently low electromagnetic interference characteristics. Any addition of metallic elements tends to degrade this advantage. Therefore, it was considered especially important in the Mod-1 blades to develop an optimized protection system which would require the minimum area of metal to be added to the blade.

To achieve the above end, a two-phase developmental test program was carried out with the assistance of Lightning Transients Research Institute (LTRI), St. Paul, Minnesota.

The first series of tests were conducted to determine the susceptibility of a composite blade, such as Mod-1, to damage from lightning strikes. The first specimen was a 15 ft long blade, 4 ft chord section representative of the Mod-1 blade; i.e., having a D-spar with 1 in. wall thickness, afterbody sandwich panels 2 in. thick, and a steel member, representative of the adapter installed at the inboard end of the spar.

The first series of tests were high voltage, long arc lightning strokes (3.5 million volts, 20,000 amperes), on the unprotected blade. These long arc tests were conducted to identify the discharge paths which lightning strokes would take during a natural occurrence. The electrical current during the long arc tests was sufficiently low to minimize damage to the test specimen, thereby allowing repeat tests and subsequent modification for lightning protection.

Some lightning discharges were attracted to the steel hub adapter inside the spar, entering the spar cavity at the blade tip. Other discharges occurred through the afterbody panels, "stitching" in and out through the panels from tip to root. If these discharges had been high current strokes (in the 200,000 amperes range), catastrophic damage would have resulted.

A lightning protection system was then installed, in stages, during subsequent long arc tests, to determine the minimum configuration that eliminates any discharge paths inside the blade. A succession of surface conductors was added until no further penetration was observed during the high voltage tests. First, a full-chord metal (and aluminum foil) tip cap having a 3-inch skirt inboard of the tip was tested, and found to be effective in eliminating the lightning path inside the spar and initiating the external discharge path along the afterbody. However, lightning penetrated the afterbody in areas away from the blade tip, possibly because the paper core was wet during these tests. Chordwise strips of foil were then added at intervals across the afterbody to provide external conductive paths for strokes which attach along the blade instead of at the blade tip; however, penetrations of the afterbody were still observed. Finally, a full span trailing edge conductor was added to carry lightning current to ground. No further penetrations of the spar or afterbody were observed with this arrangement installed.

The blade specimen, modified in the above manner, was then repositioned for high current tests (200,000 amperes) to demonstrate that lightning strokes would flash externally over the blade surface, via the conductive path, without causing damage to the composite structure. The high current tests successfully demonstrated this, although the thin aluminum foil, used in the testing for ease of configuring, was not capable of sustaining repeated strokes. A more durable material is required for the primary current path to ground.

In a second phase of tests using a more production-representative concept, braided copper wire formed as a flat strap and covered with a thermoplastic coating was selected for the trailing edge conductor; the coating was employed to minimize the axial stiffness mismatch between the conductor and the underlying fiberglass composite. On the actual blade, the plastic-coated braid would be securely bonded to the blade trailing edge and overwrapped with fiberglass cloth, but for the test specimen the glass wrap was omitted and the strap

cemented in place. The cross sectional area of this conductor was 48,000 circular mils. Prior to tests on the blade specimen, samples of glass-wrapped, plastic-coated braid were successfully tested to 200,000 amps by Lightning and Transients Research Institute at their St. Paul, Minnesota, facility. Insignificant distortion was observed.

In addition to the trailing edge strap, a more permanent, full-chord aluminum cap was installed at the blade tip and Hexcel Thorstrand[®] covering was installed at the blade root area. The latter was thought to be advisable to shield the steel internal hub adapter against lightning penetration through the composite spar to the adapter. Thorstrand[®] is a woven cloth of aluminized glass fibers. No edgewise conductor strips were added for this phase of testing, in the interest of minimizing TV interference.

As in the earlier testing, high voltage strokes were first applied to this configuration to identify lightning discharge paths. In all cases except one, the lightning stroke attached and discharged across the afterbody surface, either to the root end, the trailing edge conductor, or to the aluminum tip cap. In one test, the lightning stroke stitched into, and out of, the blade afterbody for a distance of about four inches before completing a surface discharge to the blade root.

The maximum length of surface discharge in all high voltage tests was about 65 inches. No lightning stroke attachments occurred on the blade spar; all were either on the blade afterbody or on one of the conductors. Thus, an unequivocal need for Thorstrand[®] shielding of the blade root end was not established by these tests.

Following the high voltage tests, the blade was repositioned for the high current applications to assess the ability of braided wire to sustain repeated 200,000 ampere strokes. In the first test, a 229,000 ampere current was discharged through a 20-inch section of braid bonded with contact cement along the full length of the blade trailing edge. The 20-inch section was torn from the blade by electromagnetic forces produced by abrupt direction changes in lightning current flow. Subsequently, a series of tests was conducted on 31-inch lengths of bare braid laid across the blade surface to establish the durability of the braid at various current levels. The test set up was modified to reduce the abruptness of direction changes in current flow, thereby reducing the electromagnetic forces which tore the braid loose on the previous test. The following observations were noted:

50,000 Amps	No damage
83,000 Amps	Slight tubular curling
133,000 Amps	More tubular curling
181,000 Amps	Braid curled and slightly shredded
246,000 Amps	Braid torn loose and shredded.

No damage was incurred by the blade in any of these tests.

One 217,000 amp strike on a 6-inch wide strip of Thorstrand[®] bonded to the afterbody surface rendered it ineffective for subsequent strikes, but no damage occurred to the blade itself. The aluminized coating on all glass fibers parallel to the direction of current flow was vaporized by the lightning stroke.

Results of the various tests, described above, indicate that the Mod-1 protective system, Figure 7, consisting of the full-chord aluminum tip cap and the coated trailing edge braid grounded to the inboard adapter fitting, and the Thorstrand[®] shield will provide effective protection for 100 ft. Mod-1 blades. It is expected that the braid will protect the blade against damage from numerous lightning strokes up to 100,000 amps, probably a limited number up to 150,000 amps, and at least one stroke at 200,000 amps. It is likely that maintenance action will be required to repair damaged braid after a 200,000 ampere lightning stroke.

A third series of tests has been proposed to NASA to determine the durability of the system itself under repeated strokes. This investigation would focus on the trailing edge strap attachment to the afterbody surface, with special attention to the strap's change in direction of approximately 35° at the diagonal inboard end of the afterbody. The testing would consist of a series of high current charges applied to a representative sample of the conductor at the direction change point of the afterbody. Current would be gradually increased until damage to the braid attachment became evident. Then, a second, undamaged specimen would be struck repeatedly with amperages just below the damaging level to qualify the braid for a number of successive strokes. To date, this test phase has not been contracted.

The chosen system is readily repairable, in place, should damage to the braid or its attachment be encountered. NASA requested that the spanwise conductor be mounted on the underside of the trailing edge to facilitate inspection since this side of the blade can be best viewed from the tower.

Kaman has advised that a simple detection device be installed at each blade's attachment which would signal that a high amperage stroke had been experienced. In that event, a special inspection of the blade's protection system could be made.

7.0 BLADE MANUFACTURE

Fabrication procedures used in building the two Mod-1 blades generally followed those developed for the 150 ft. blade, except that all manufacturing phases of the Mod-1 blades were carried out by Kaman.

Tooling and manufacturing operations were kept extremely simple for cost saving as befit the manufacture of two articles only. In some cases, the same actual tooling used in the 150 ft blade was adapted for Mod-1. Many hand operations were also employed which would be mechanically implemented in a production situation.

Manufacture was carried out with the close cooperation of NASA personnel, whose presence at Kaman and constructive participation in the on-going development of fabrication procedures proved most helpful.

The following paragraphs describe tooling and manufacturing processes employed for each of the elements of the blade, Figure 5.

7.1 Spar

Construction steps and sequences are as follows:

Step 1 - 17 in. wide tape (TFT) and a highly-tensioned 8 in. wide band of hoop rovings were simultaneously applied by winding around a rotating mandrel, Figure 10. The TFT/hoop band was applied, from a slowly moving carriage, at a shallow helix angle with approximately fifty percent overlap upon itself. Resin was introduced by both preimpregnation and hand application. Thirteen courses or one-way passes of TFT/hoop, from root to tip, were required, Figure 11, each followed by deposition of only the hoop band on the return pass. Tapering of the spar wall thickness near the tip end was effected by shortening certain of the passes, beginning 7 ft. from the tip. Manual rolling was employed to assist the action of the hoop band in compacting the TFT and squeezing out resin and trapped air, Figure 12. Feed of the roop rovings is shown in Figure 13.

Step 2 - Between each of the above TFT/hoop winding runs, hand layup of variously configured layers of reinforcing material was performed at the root end of the spar. All such lengths were pre-cut and applied in an established sequence. Each layer of reinforcing fabric was compacted by a short out-and-return pass of hoop tape, plus manual rolling.

Step 3 - Upon completion of all of the prescribed winding passes and root end reinforcement placements, outer layers consisting of a nylon fabric peel-ply, an FEP release film (perforated), and dry hoop fibers were wound over the wet laminate to aid compaction and bleed excess resin from the outer layers.

Step 4 - An oven enclosure was moved into place over the entire length of spar and the laminate cured for five hours at 180 - 200°F.

Step 5 - The cured spar was pushed loose from the mandrel by actuation of hydraulic jack cylinders exerting force against the free bucking ring which is in contact with the root end of the spar, as shown in Figure 14.

Tooling - The winding system, Figure 10, consists of the rotating mandrel, traversing carriage, means of driving the mandrel rotation and carriage travel, and the basic mandrel support members; i.e., headstock, tailstock, and main roller reaction structure. The mandrel is supported essentially as a propped cantilever since only a very low reaction force is provided by the tailstock. Such an arrangement provides a free span for the entire spar portion of the mandrel, without the mid-span steadyrest which was employed in the winding system used for the 150 ft blade spar. Thus, the Mod-1 spar could be entirely wound in a single operation, whereas the 150 ft spar required four winding and curing steps to accommodate the interrupted span. This feature is considered a significant improvement introduced in the Mod-1 tooling.

The mandrel itself, Figure 15, is a steel weldment designed by Kaman and manufactured by a welding shop in California. The 130 ft long completed mandrel was shipped to Connecticut by rail without difficulty, as shown in Figure 16, in much the same manner as was the 150 ft blade spar. Design of the mandrel utilized bulkhead, stringer, and heavy steel skin construction for the spar portion, and rolled steel pipe for the reaction beam at the headstock end of the assembly. Bulkheads were flame cut to mylar contours provided by Kaman. The computer-derived contours allowed for the effect of varying compaction of the laminate around the perimeter of the spar with its changing radii of curvature.

Preimpregnation of TFT rolls was done in the same pressure-vacuum tank utilized in the 150 ft spar winding. Cycles of positive and negative pressure were found necessary to drive all of the air from the relatively heavy fiber bundles which make up the transverse rovings. This method of pre-wetting is a time-consuming process which Kaman has successfully eliminated in other TFT blades by use of lighter weight TFT. The continued use of 36 oz/sq. yd TFT material, first employed in the 150 ft spar, was required by NASA so that the extensive laminate testing work of the latter program could be carried over directly for Mod-1.

The curing oven consists simply of a series of eight open-ended enclosures which are placed over the spar, end-to-end, to form a shed-like cover. Walls of the enclosure are plywood with insulation covering. Heat is provided by two air heaters, and laminate temperatures are monitored by use of thermocouples imbedded in the spar wall during winding.

Provisions for pushing off the spar from the mandrel consist of twenty 5.5 in. diameter hydraulic cylinders with a 3,500 psi system capacity. Each cylinder has a stroke of 24 in., and can apply a force of 83,000 lbs., or 1.66×10^6 lbs. total for 20 cylinders. A force of approximately 1.5×10^6 lbs consistently broke loose the three spars constructed. No problems were experienced with this arrangement, Figure 13.

The above spar winding process was successfully utilized in the manufacture of three Mod-1 spars, each of which involved the deposition of nearly 20,000 lbs of fiberglass and resin material. The first spar was

wound for trial purposes, and was later used for static buckling tests. It contained bias tape (BFT) added at mid-span on the bottom surface to improve buckling stability; this spar required 7.5 days for the winding process. The second and third spars required 5.5 days and 4.5 days, respectively; these were the spars used for the two blades. It is believed that these times could be bettered considerably in a production set-up in which the local reinforcement plies would be machine-applied, the pre-wetting of TFT eliminated by use of lighter weight material, carriage speed and mandrel rpm increased, and material handling procedures and equipment improved.

Some difference in percentage of resin content between the two spars was evident from a laboratory examination of the two laminates, and was later reflected as a significant weight variation in the finished blades. The investigation of manufacturing differences which led to this variation is still in process, but the most likely contributor may be a change in resin squeeze-out technique which had been introduced in the winding of the second spar. Evidently, resin content of this type of laminate is more greatly affected by seemingly small differences in technique than was previously appreciated. It is felt, however, that such differences were largely the result of the essentially hand fabrication methods used in this program. Introduction of production process controls should greatly reduce spar to spar differences with resulting satisfactory weight control.

7.2 Afterbody Panels and Installation

Panel Fabrication. Manufacture of the six afterbody panels directly utilizes the technology developed by Kaman for the ten similar panels of the 150 ft. blade. Construction steps and sequence are as follows:

Step 1 - The outer skin, consisting of two plies of prepreg 1583 cloth, was trimmed and fitted to a female caul plate, followed by layups of four doubler plies at the leading edge and at panel ends. These operations, and Steps 2 and 3, were carried out in a cleanroom.

Step 2 - Honeycomb core material was added, in previously dry-fitted pieces, including the beveled trailing edge section. Strips of Cybond 5001 foaming adhesive (in dry sheet form) were inserted between the core sections, and at the outer edges of core. Two additional plies of cloth were added at the panel ends (a total of eight plies).

Step 3 - The inner skin, consisting of one ply of 1583 cloth, was fitted and placed over the core and covered with an aluminum caul sheet over the entire core area. Edge support blocks were then added to prevent core collapse under curing pressure.

Step 4 - The entire bond fixture with the panel layup was moved from the clean-room into an autoclave. Curing of the panel was done under 13 psi pressure at 270°F for 4 - 6 hours.

Tooling - Tooling for the Mod-1 panel fabrication consists of the large panel bond fixture, Figure 17, used for the 150 ft blade afterbody. This fixture is, essentially, a curved caul plate supported on a steel frame. Since the fixture is made completely adjustable to accommodate panel curvature and twist, the changes necessary to convert to the Mod-1 panel requirements were simply done. Some refurbishment of the fixture was found necessary at the outset of the Mod-1 work and new detail parts such as core support blocks and upper caul skins were required. For manufacture of each of the six panels, a new twist setting was required, accomplished by use of the mechanical adjustment jacks located at the ends of the tool.

The only difficulty encountered in building the six Mod-1 panels was a problem of local crushing of the core during the pressure/cure cycle. Each such damaged local area had to be repaired by inserting replacement sections. The problem was traced to the core supplier's manufacturing process; resin used to impregnate the paper had been incompletely cured. Subsequently, Kaman put the as-received core material through a baking cycle to ensure that the resin had reached full hardness. No further instances of core crushing occurred.

Panel Installation. Although the same general procedure as developed for the 150 ft blade panel installation was used for Mod-1, an exception was taken in the procedure for manufacturing and installing the T-clip which attaches the panel inner skin to the spar rear wall, Figure 4. When the 150 ft blade was sectioned after the tests to failure, the T-clip bond was found to be marginal. Consequently, an entirely different approach was taken in manufacturing this important connection in the Mod-1 blade.

Installation of the panels involved the following manufacturing steps and sequences:

Step 1 - The panels were dry-fitted and trimmed to size in the assembly fixture described elsewhere in this section. Care was necessary in this process to ensure correct placement so that the outer skin would come tangent to the spar outer lap joint, and so that the trailing edge placement would not introduce undue strain in the panels. The trimmed core edges, forward and rear, were then filled with syntactic foam and capped with a wet lay-up of glass cloth and epoxy resin. All movements of the panels in and out of the fixture were accomplished by hand.

Step 2 - Each panel's full length T-clip was constructed as a wet lay-up with the panel in place. First the inner leg of the clip was constructed, using the panel surface as a locator, and cured at room temperature. Then followed lay-up of the outer leg. Epoxy adhesive was introduced to fill the void at the intersection of the two legs prior to layup of the second leg. T-clips for the upper panels were constructed first, followed by those for the lower panels.

Step 3 - Peel ply was removed from the bonding surfaces of the panels and spar, adhesive added, and each upper and lower pair of panels bonded in place. The adhesive was allowed to cure at room temperature for a 16 hour period prior to release or clamping pressure..

Step 4 - After removal of the fixture frame, syntactic foam was injected into the cavity between the forward edge of the panel and the spar rear wall. Temporary holes were drilled through the outer skin for this purpose; these were later covered with fiberglass cloth/epoxy patches.

Tooling - Tooling for the foregoing assembly operation was essentially the same as that developed for the 150 ft blade and, in fact, used many of the same hardware pieces. This tooling, Figure 18, consists of wood contour headers which act as cradles for the entire length of spar, and a movable steel framework covering one panel length. The latter incorporates 30 ft long pneumatic hoses which, when inflated with air, exert bonding pressure at the lap joints of the outer skins to spar. For the panel inner skin-to-T-clip bond, rubber-faced backer bars are provided, held in place by temporary bolts. Bonding pressure for the trailing edge joint is provided by bar-clamps. Once the bonding of the inboard upper and lower panel set was completed, the entire framework assembly was moved to the center pair of panels and, finally, to the tip pair.

The above tooling and manufacturing process resulted in a sound, well bonded afterbody structure. However, the laborious amount of hand fitting and locating of the components added many hours of labor and schedule time which could be greatly reduced by employment of production tooling.

7.3 Secondary Composite Operations

This section deals with fabrication of the various wraps and closures which complete the fiberglass portions of the blade:

Trailing Edge Wrap - After all of the afterbody panels had been bonded in place, and the trailing edges of the upper and lower panels bonded together, a narrow cap was installed along the trailing edge. This was applied as a three-ply wet lay-up of 1583 glass cloth and epoxy resin, vacuum bagged, and cured at room temperature.

Inboard End Closure - A canted panel, roughly triangular, was installed as a closure at the inboard end of the afterbody. The sandwich panel itself was constructed on a flat caul plate with two-ply inner skin, 1.0 in. thick paper core, and two-ply outer skin. Layup procedure for the prepreg skins and support of the core was the same as employed for afterbody panels, as was the cure operation.

The panel was fitted, trimmed to final shape, and bonded to the trimmed (and capped) edges of the inboard upper and lower panels.

Seven-ply edge doublers of glass cloth/epoxy were then installed as a single wet layup to reinforce each of the closure-to-panel corners, and vacuum bag cured at room temperature. The intersection of the panel and spar was reinforced with a wet layup using bias-cut cloth.

Chordwise Overwraps - At the request of NASA, each panel was provided with a redundant attachment to the spar which consisted of a continuous fiberglass band wrapped from the panel trailing edge around the leading edge and back to the trailing edge. Bands were placed in the center of each panel and at the panel-to-panel joints (5 locations total), as shown in Figure 3. The lightning protection tip cap precluded a band at the tip of the outboard panel, and a special treatment was given to the inboard end of the most inboard panel, as described above.

Each of the five wraps is ten plies in thickness, and up to 36.0 in. wide. After some experimentation, a process was developed for wet layup in two ply stages. Due to the large area involved, and the vertical orientation of the blade which was necessary in order to work on both sides, a special method of resin squeeze out had to be developed to avoid problems of uneven thickness and poor surface finish due to excess resin. Each group of plies was cured under vacuum pressure at room temperature. Figure 19 shows the five chordwise overwraps on the unpainted blade.

7.4 Adapter Fitting and Installation

Adapter Fitting Manufacture. The adapter fittings were fabricated by a metal-shop vendor in California. Each was fabricated in three sections (Figure 6), consisting of a flanged end member machined from a forged ring, and two rolled rings. The latter are slightly conical in shape and were cold formed by rolling 1.5 and 1.25 in. thickness steel plates. The material for all three elements is HY80 steel.

Very little special tooling was required other than profile templates for final tracer machining of the radii which blend into the end flange. One other tool was used, a hole location template for positioning of the 56 blade mounting bolts which must match the holes in the ROTEK pitch bearing in the Mod-1 hub. The template was provided by ROTEK, who used the same N-C tape in machining its holes as that used in machining the bearing.

The three rings were machine welded, using shielded arc and multiple passes with preheating. This procedure required considerable development, i.e., finding the right combination of weld bead size and preheat to prevent cross checking cracks from occurring internal to the weld.

The adapter fitting was machined all over after weld completion. Certain critical areas were shotpeened. Pilot holes, 1 in. diameter, were drilled at each of the eighteen adapter-to-spar bolt locations, and the 56 1.311/1.324 in. diameter adapter-to-hub holes were drilled, Figure 20.

Fitting Installation. This phase of manufacture covers the permanent installation of the adapter fitting into the inboard end of the spar, and the fastening to the spar by eighteen sets of bolt/bushing hardware. Steps in this manufacturing process were as follows:

Step 1 - The adapter fitting, after priming, was placed in the end of the spar using heavy moving equipment. Precise location and alignment was then accomplished through the use of optical tooling methods discussed at the end of this section.

Once aligned, the spar was match-drilled to the pilot holes in the adapter, and the adapter fitting was fastened in place by means of 1-in. diameter temporary bolts. The fitting was then permanently bonded into the spar by injecting epoxy adhesive into the spaces between the fitting outside diameter and the spar cavity. Epon 828 (and RD-2) was used, with Anca-mide 506 for increased pot life and Cabosil for thixotropic improvement.

Step 2 - Each of the 1 in. holes in the spar was next enlarged to the full 4.4 in. diameter of the bushing. This process utilized a Bridgeport boring head supported on a steel frame which was mounted to the face of the fitting using the blade attachment holes. The boring operation used a series of cutters, starting with carbide tipped hole cutters of increasing size up to 4.0-in. diameter, followed by a carbide boring tool for the final diametral cuts. Each hole's centerline had to be oriented perpendicular to the spotfaces in the fitting to ensure proper seating of the bushing upon assembly; this was accomplished by means of dial indicator measurements off the spotface. During the machining process, large diameter, radiused spotfacing of the composite was also accomplished to provide a land for seating of washers, Figure 6. The 1 in. diameter pilot holes in the fitting were then enlarged to 3.0 inches.

Step 3 - Each composite spotface was next coated with adhesive and cured, after which a circular fiberglass fabric cover was applied as a wet layup over the entire area of composite exposed during spotfacing, and cured. During curing a circular disc was clamped against the spotface area to ensure a smooth land.

Step 4 - The final bolt and bushing assemblies were next installed, and torque applied by use of a large hydraulic wrench. In this process, a special tool was inserted through the 0.5 in. bore of the bolt for the purpose of measuring bolt tensile deflection during torquing. A stretch of 0.012 to 0.014 in. was desired for proper bolt tension; this was achieved at a wrench torque of approximately 10,000 ft-lbs. The torque applied to the outer nut was reacted by use of a large box-wrench placed on the inner nut and trapped against adjacent hardware to prevent rotation. After torquing, the nuts were safetied by means of local tack welds to the bolt.

Tooling - Tooling was provided to assure proper alignment of the fitting in the spar. This consisted of a special metal template which was manufactured and placed inside the spar at the three-quarter blade radius station. Scribed on the template were the chord plane line and the quarter-chord intersection point on the chord plane line. To be properly aligned, the cylindrical fitting's centerline axis must coincide with the quarter-chord line. This was accomplished by optically locating the fitting axis, then physically shifting the fitting until this axis optically intersected the quarter-chord "target" on the template. Pitch orientation about the quarter-chord axis was accomplished by first optically creating a plane defined by the fitting's centerline and the center of one of the 56 holes on the flange of the fitting. Then the fitting was physically rotated until this plane optically coincided with the chord plane line scribed on the template. By this means, the fittings were successfully oriented with respect to their quarter-chords and outboard angles of incidence, and hence to each other. The resulting fitting alignment of the two blades matched within $0^{\circ}1'44''$, and matched in pitch to within $0^{\circ}3'3''$.

The other items of tooling were the bracket-mounted Bridgeport boring head, the bolt stretch tool, and miscellaneous work aids for hole boring and for the composite cap over the spotfaced composite. The set-up for hole boring is shown in Figure 21.

7.5 Lightning Protection and Ice Detector

Manufacture of the lightning protection components was straightforward and accomplished without difficulty or extensive development. Only one tool was required, for the imbedding of the flattened copper braid in its thermoplastic sheath. This operation was done in a heated platen press using a fixture to hold the plastic-braid-plastic sandwich of 0.08 in. thickness together in a straight line while 300°F heating was applied. Another fixture was used to build-in the 48 in. radius curve in the strap for the point where it travels around the 35° canted inboard end of the afterbody. When the strap detail had been completed, it was clamped and bonded along the lower trailing edge of the blade using EA913 adhesive, cured at room temperature. Following this, the two-ply overwrap was installed as a wet layup with vacuum bag curing.

The tip cap was built as a sheet metal weldment of 6061 aluminum alloy.

A single ply of Thorstrand[®] cloth was applied as a wet layup outer ply at the root end of the spar after completion of the spar curing operation. The Thorstrand[®] wrap was vacuum bag cured at room temperature.

Installation of the ice detector required only that a 5.08-in. diameter hole be provided in one afterbody panel, and that a wire harness be constructed and bonded to the outside of the blade. No special tooling was required. The cut edges of honeycomb in the hole were reinforced with syntactic foam and capped with a single fiberglass ply. The wire harness was encased in shrink tubing and bonded to the surface, then covered by a single ply wet layup.

7.6 Paint

Application of the paint system included a minor amount of surface preparation followed by one coat of primer, a mist coat of urethane, and the final top coat. The outer peel-ply on the surfaces of the afterbody panels had been kept in place until just before the painting operation, thus ensuring a clean, primer-ready surface. The spar was left essentially in an as-wound condition, without filling of the slight winding undulations, since it was desired that the blades be representative of commercial production articles for which little cosmetic preparation will be feasible.

Painting such large surface areas indoors, using low flash point materials, necessitated special safety precautions. Also, respirator systems with bottled breathing air were required for all personnel, and considerable attention was given to room ventilation by forced air.

A buildup of three extra coats of urethane was applied at the leading edge from station 812 outboard for erosion protection; the coats were feathered out at approximately 20% of chord. Paint was applied inside the adapter in order to protect the inner hardware.

At NASA's request, the first and second Mod-1 composite blades were identified with the numbers 3 and 4, respectively, inasmuch as the steel blades were numbers 1 and 2.

8.0 QUALITY ASSURANCE

A number of different inspection methods and approaches to quality control had been developed and evaluated during the 150 ft blade program recognizing the special challenge introduced by the large size of the blade and its components. From this work, it was concluded that while conventional inspection and control methods are adequate for quality assurance in large composite blades, primary emphasis should be placed on problem prevention rather than problem correction. Specifically, primary attention is given to controlling each step in the manufacturing process, rather than depending heavily upon inspection of the finished article. Not only are the finished components difficult to inspect, but at the completed stage they are costly to repair.

Submittal of a Quality Assurance Plan for the Mod-1 blade was a requirement at the Detail Design Review. Rather than prepare a specially written narrative plan, the actual Kaman Manufacturing Traveler to be used in the shop during the shop building of the blade was presented. This is an in-house working document which defines every step in the manufacturing and quality control process. During the building of the blades, this document was closely followed with only minor deviations and changes introduced as processing steps were developed or modified. The table given below, lists the quality control measures employed in manufacturing the major items in the blade, i.e., the spar, afterbody, and adapter fitting.

This partial table, while not including here such additional manufacturing steps as secondary overwraps and closures, lightning protection and ice detector installations, etc., is intended to illustrate the level of quality control applied and, in particular, the emphasis given to in-process control. In addition, tooling manufacture and set up were also subjected to vendor and in-house inspection.

Corrective actions used in repairing such defects as incomplete bonds, voids, delaminations, core crushing, etc., were accomplished using repair practices common in the aircraft industry.

Complete inspection logs were kept for all components, subassembly, and final assembly operations. These were reviewed periodically with NASA quality assurance personnel.

<u>COMPONENT</u>	<u>OPERATION</u>	<u>QUALITY CONTROL MEASURES</u>
SPAR	As-recieved material	Material affidavits from source Sample testing
	In-process material usage	Weighing of ingredients; every mix Mixing time measurement; every mix Oven checking of resin sample cure time; every mix Monitoring resin application time vs pot life Monitoring weight of resin prepared and used
	TFT pre-impregnation	Checking pressure/vacuum levels, number of cycles, cycle time
	Winding	Monitoring number of plies, winding pass length, root end reinforcement ply sequence, presence of voids, roving band uniformity
	Curing	Monitoring oven temperatures, cure time
	Finished laminate	Laboratory analysis of cut off end samples for: Glass weight and volume (%) Resin weight and volume (%) Density Void content
	As received material	Material affidavits from source
	Panel layup	Ensuring material cleanliness Verification of refrigerated storage history and age of prepreg skins and film adhesive Dimensional checking
	Panel curing	Checking integrity of vacuum pressure prior to autoclave cycle Monitoring of autoclave temperatures, pressure, time
	Finished panel	Tap testing for voids or delaminations Inspection for core crushing
AFTERBODY PANELS		

<u>COMPONENT</u>	<u>OPERATION</u>	<u>QUALITY CONTROL MEASURES</u>
PANEL INSTALLATION	Pre-fit of panels	Checking for gaps, panel strains, panel damage
	Final installation	Monitoring mixing of adhesive, syntactic foam Monitoring air bag pressure, cure time Tap testing for delamination Inspection for voids in syntactic foam Inspection for panel mis-match
ADAPTER FITTING	Forging	Reviewing material affidavits from source
	Welding	Checking welded samples for: porosity, slag inclusions, penetration, cracks, hardness, tensile strength Dye penetrant inspection of each welding pass for cross-checking X-Ray of finished welds Ultrasonic check of finished welds
	Machining	Use of special drilling template for holes
	Finished part	Inspection of critical dimensions Ultrasonic measurement of wall thickness Inspection of shot peening
FITTING INSTALLATION	Location in spar	Independent optical check of location and alignment of fitting
	Bonding in place	Material affidavits from adhesive source Monitoring mixing procedures Monitoring adhesive injection Checking adhesive cure
	Bolt details	Source inspection of materials, dimensions, plating
	Bolt installation	Checking each hole bore for alignment, depth, diameter Monitoring bolt torquing procedure and stretch measurement.

9.0 WEIGHT AND BALANCE

Measurement of each blade's weight and spanwise center of gravity location was carried out after completion of fabrication. Edgewise CG measurement was waived by NASA to simplify the overall task with resulting cost reduction. Edgewise CG had been calculated at the time of Final Design Review at 27.6% of chord (at the spanwise CG location), well within the contract specification's aft limit of 35%. Although certain design changes were introduced after that point, e.g., removal of bias ply buckling reinforcement (BFT), addition of circumferential wraps, and addition of the lightning protection system, these were determined analytically to have only a minor effect on edgewise CG; therefore, measurement of edgewise CG was not considered warranted.

For weighing, each blade was positioned horizontally with leading edge down, supported at two points. The inboard support, at station 190, was a simple bridge-like arrangement incorporating two calibrated load cells which were read on an SR-4 strain indicator. The outboard support, located at station 660, consisted of a cross beam bridge member resting on two direct-reading aircraft scales. The blade's quarter-chord line was leveled during the weighing process.

Weight readings were taken using the above setup, and tare weight subtracted. The entire procedure was then repeated, including a repositioning of the supports, to assure repeatability. Results were as follows:

Blade No. 1	25,698 lbs at station 354.9
Blade No. 2	26,846 lbs at station 360.2

The 1,148 lb difference in weight, approximately 4%, is attributed mainly to variations between the two spars, since the other components such as afterbody panels and adapter fittings had been individually weighed and showed only small weight differences. Variation in spar manufacturing techniques which are considered to have contributed to the weight difference are discussed in paragraph 7.1.

The optimum means of matching the weight of the blades to an acceptable level will be developed as part of the pre-delivery natural frequency tests still to be conducted, Section 10.0. This will enable selection of the best location and weights for mass balance with regard to both static and dynamic effect. Balance weights, made of cast composite bonded inside the spar cavity, are envisioned.

Several incremental steps of allowable weight increase have occurred since establishment of the original upper limit of 20,000 lbs stated in the contractual specification. It became clear at the preliminary design stage that increasing the in-board beam depth for bending stiffness and strength would result in a significant weight increase. However, it was recognized that the influence on first moment is a more significant criterion, and the spar weight growth had little adverse effect on moment since the increase was primarily at the inboard end. Several other weight-increasing design changes were introduced as the program progressed, each approved by NASA after evaluation for any significant impact on the Mod-1 system interface.

10.0 PREDELIVERY TESTING (PLANNED)

Discussed in this section are certain tests which will be conducted prior to shipment of the blades to the wind turbine site. These include bending proof load testing and natural frequency determination. Also to be accomplished during these tests are calibration of the blades' permanent instrumentation system, blade stiffness measurements, and the development of a blade ballasting configuration for static and dynamic matching.

10.1 Bending Proof Load

The purpose of these tests is to prove that the blade can withstand full design limit loading for the critical edgewise and flatwise conditions without permanent deformation or damage. The testing will also be used to calibrate the blade's permanent instrumentation system and to measure blade stiffness in the edgewise and flatwise directions.

To accomplish the above testing, the blades will be mounted as a cantilever beam, Figure 22, on Kaman's outdoor fixture developed for the 150 ft blade tests, Figure 2. The fixture will be adapted to accommodate mounting of the blade using identical bolts to those which will be installed for blade attachment to the Mod-1 hub. A feature of the test fixture permits the entire blade and reaction beam assembly to be rolled 90° as a unit to permit both edgewise and flatwise loading.

Load application will be at station 825 by means of a contoured clamp and hydraulic cylinder with strain gage load link, and at the tip station 1210 where loads will be applied through a chainfall with load link. Both blades will be tested and calibrated in this manner.

Applied loads for the critical limit load conditions are:

<u>Case</u>	<u>Sta. 825 Load (lbs)</u>	<u>Sta. 1210 Load (lbs)</u>	<u>Critical Condition</u>
Edgewise	0	690	120 mph hurricane
Flatwise	13,160	6,235	27.3 rpm overspeed shutdown

Output from the blade's strain gage bridges will be fed to a computer-controlled data acquisition system which will format and store all channels of data for subsequent analysis.

10.2 Natural Frequency

This phase of testing will determine blade natural frequencies in the edgewise, flatwise, and torsional modes. Spanwise ballasting, for blade static and dynamic matching, will be checked out during this test phase.

Natural frequencies will be measured with the blade mounted as a cantilever oriented in both the edgewise and flatwise modes. The blade will be excited by manual shaking for the lower fundamental modes and by impact tests for the higher bending and torsion harmonics. Responses will be measured by two fixed

accelerometers at the blade tip. The output of one will be recorded on an oscillograph for determination of blade damping. Output of the other accelerometer will be recorded by a digital signal analyzer. Blade strain gage bridge output will also be recorded on an oscillograph as an aid in identifying mode shapes and frequencies.

Blade torsional response will be measured by two accelerometers located at the leading and trailing edges.

A preliminary check of the free-free natural frequencies was conducted prior to moving the blades from their manufacturing area to the storage location, with NASA and GE witnessing. In this test, each blade with accelerometers was suspended from a crane with two straps and a spreader bar, and impacted at the tip with a heavy calibrated mallet, as shown in Figure 23. Results showed the first flatwise mode at 3.980 ± 0.025 Hz and the second mode at 9.77 ± 0.05 Hz. These results and the mode shape closely verified analytical predictions.

11.0 SHIPPING, HANDLING (PROPOSED)

Although the contract for the Mod-1 composite blades does not include the task of shipping them to the wind turbine site, a preliminary investigation of transportation possibilities was carried out.

Valuable background information had been gained from the prior experience of The Boeing Company in shipping their steel Mod-1 blades from Seattle, Washington, to Boone, North Carolina, in 1979. For that operation, road transportation was used, each blade being shipped by trailer truck.

In order to transport the steel blades, a specialized trailer was developed which supports the blade canted at approximately 45° (for height reduction). Special mounting provisions prevent torsional or tension loading from being felt by the blade in transit. The rear end of the trailer was mounted on a standard steerable dolly which was needed primarily for the sharp turns of the road up Howard's Knob to the base of the Mod-1 tower.

An assessment was made to determine whether the steel blade trailers could be used directly for the composite blades. It appears that this is feasible, but some modification or replacement of the mounting hardware would be required. Specifically, the difference in chord of the Mod-1 blade necessitates rework or replacement of the rear trailer support rocker and its blade cut-outs. It also appears that the height of the composite blade (or metal blade), if transported on the existing metal blade front support would exceed the maximum height regulations for Connecticut highway use. Modifications necessary to accommodate both of the above concerns should be relatively simple to achieve, and could probably be done in a way that would allow either metal or composite blades to be transported on the equipment.

Shipment by rail is also feasible with each 97.4 ft blade mounted on an 89 ft flat car. Overhang would be accommodated by stationing empty flat cars on each end of the central car. Such an arrangement was successfully used in transporting the 150 ft blade spar (actual length of spar was 141 ft) from California to Connecticut. The 130 ft steel winding mandrel for the Mod-1 composite spar was also transported across the country in this way, Figure 16. From a preliminary dimensional study, it would appear that the various railroads' height limitations, which in the worst case is 16 ft 2 in., can be accommodated by canting the blade.

Based on the foregoing, it is concluded that the shipment of the Mod-1 composite blades to Boone, North Carolina, can be accomplished without excessive difficulty.

Lifting and handling of the blades by crane at the Mod-1 site, can utilize the arrangement provided for the metal blades. This was a two-point suspension with cables attached at the inboard fitting and at approximately the two-thirds span station. Attachment at the latter point made use of a split fitting which clamped over the blade and, being circular, permitted the blade to be rolled around its own axis as well as lifted. The lifting crane raised the blade by use of a strongback beam which accommodated the two-point suspension. Only minor modifications to this equipment should be necessary for the Mod-1 composite blades.

12.0 COSTS

In determining the recurring costs expended for the Mod-1 blades, certain special considerations should be noted.

First, as discussed in Section 7.0, the two blades were built on soft tooling and by shop methods suitable to the manufacture of two articles only. Thus, much hand labor was employed in lieu of automated methods; an example is the hand lay-up of over 150 layers of broadgoods for local reinforcement at the spar root end. For the afterbody panel installation, the critical location and orientation of the T-clips was accomplished without use of locating or holding fixtures. Hole preparation of the adapter-to-spar hardware was done entirely without drilling fixtures or gauges, necessitating dial indication for perpendicularity and individual diameter measurements for each of the 36 holes. Many other labor-intensive hand operations were employed throughout the blades.

In addition, a considerable amount of manufacturing development and tool tryout was involved in the building of the first blade. The second blade benefitted from this non-recurring effort and represented a more straightforward fabrication job with a minimum of further development needed. For this reason, the second blade is considered the more representative baseline for the cost of the Mod-1 blade.

The actual cost of manufacturing Blade No. 2 is summarized in the following table.

ACTUAL COSTS* OF BUILDING NO. 2 BLADE			
COMPONENT	THOUSANDS		
	LABOR	MATERIAL	TOTAL
Spar	\$ 50	\$ 111	\$ 161
Afterbody Panels	17	11	28
Adapter Fitting, Bolts (Vended)	---	24	24
Assembly, Paint	80	14	94
TOTALS	\$ 147	\$ 160	\$ 307

*All "costs" include 7% fee, thus they represent cost to customer (1981 dollars).

The above equates to \$11.45/lb (1981 dollars) based on a blade weight of 26,800 pounds. For comparison purposes, like costs for the 150 ft blade were \$14.50/lb (1981 dollars).

Costs have been projected for a production run of 100 blades of the present design. The following learning curve slopes for each of the various elements of the blade were selected based on Kaman manufacturing experience and published data:

Spar	92%	Machine operation with relatively low labor requirement
Afterbody Panels	85%	Considerable labor involved in material cutting and layup
Assembly	80%	High labor content for handling and fitting of panels and adapter hardware installation
Material	97%	The learning curve slope results from material resourcing and value engineering effects. Conservatively includes vendor fabrication of adapter fitting.

The above slopes are based on the introduction of a level of production tooling and fixtures commensurate with the relatively small production quantity of 100 blades. This includes such items as improved afterbody locating fixtures, tooling for more rapid boring of holes for adapter fitting hardware, locating fixtures for T-clips, in-place panel installation bond fixture, etc.

Utilizing the above learning curve slopes, costs for the 100th blade are projected as follows (1981 dollars):

ESTIMATED COSTS OF 100th BLADE			
COMPONENT	THOUSANDS		
	LABOR	MATERIAL	TOTAL
Spar	\$ 25	\$ 87	\$ 112
Afterbody Panels	5	8	13
Adapter Fitting	--	6	6
Assembly, Paint	12	11	23
TOTAL UNIT COST	\$ 42	\$ 112	\$ 154
COST PER POUND			\$5.75

It should be noted that certain features of the design represent cost drivers; these resulted from NASA's requirement to retain the design approach used in the 150 ft blade, and from the special need for equivalence with the steel Mod-1 blades. The former includes such design areas as the bolted adapter fitting and the built-up afterbody assembly. More production-oriented designs have been demonstrated to improve these areas, with attendant cost reduction.

13.0 CONCLUSIONS, RECOMMENDATIONS

As the result of this program, two composite blades have been successfully produced, meeting the Mod-1 interface requirements, which will permit operational evaluation of the benefits of composites for large wind turbine blades.

The anticipated potential of composites for reducing manufacturing and life-cycle costs in WECS blades continues to be borne out as the result of the work of this program.

Analytical methods developed for the 150 foot blade, and refined for the Mod-1 blades, are adequate for design of operation-capable blades.

Similarly, the manufacturing techniques developed in both blade programs, particularly the TFT approach for applying composite materials, have been successfully utilized to produce operation-capable blades. The method of resin application in the spar winding process will require further development in production to ensure consistent spar weight control.

It has been determined that lightning protection is necessary for an all-composite blade. An effective protection system has been developed which meets NASA's 200,000 ampere stroke requirement.

Additional tests of the lightning protection system should be implemented to determine its capacity for sustaining repeated strokes.

Cost of the Mod-1 Blade No. 2 was \$11.45/lb in 1981 dollars, using soft tooling and many hand operations. Production methods and quantities would potentially reduce the cost level to approximately \$5.75/lb for the 100th blade.

It is recommended that the Mod-1 composite blades be installed and operated so that the performance and maintenance characteristics of large composite blades can be assessed as a function of time and environmental exposure.

14.0 REFERENCES

1. Gewehr, H. W., NASA CR-159775 (DOE/NASA/0600-79/1), dated September 1979, "Final Report, 150 Foot Composite Blade Program", NASA Contract #NAS3-20600.
2. Kaman Stress Report #S-241, dated 8 November 1979, "Structural Analysis of the Composite Rotor Blade for the Mod-1 Wind Turbine," with Appendix II dated 12 August 1980.
3. Bankaitis, H., NASA TM-82601, dated 26 July 1981, "Lightning Accommodation Systems for Wind Turbine Generator Safety."

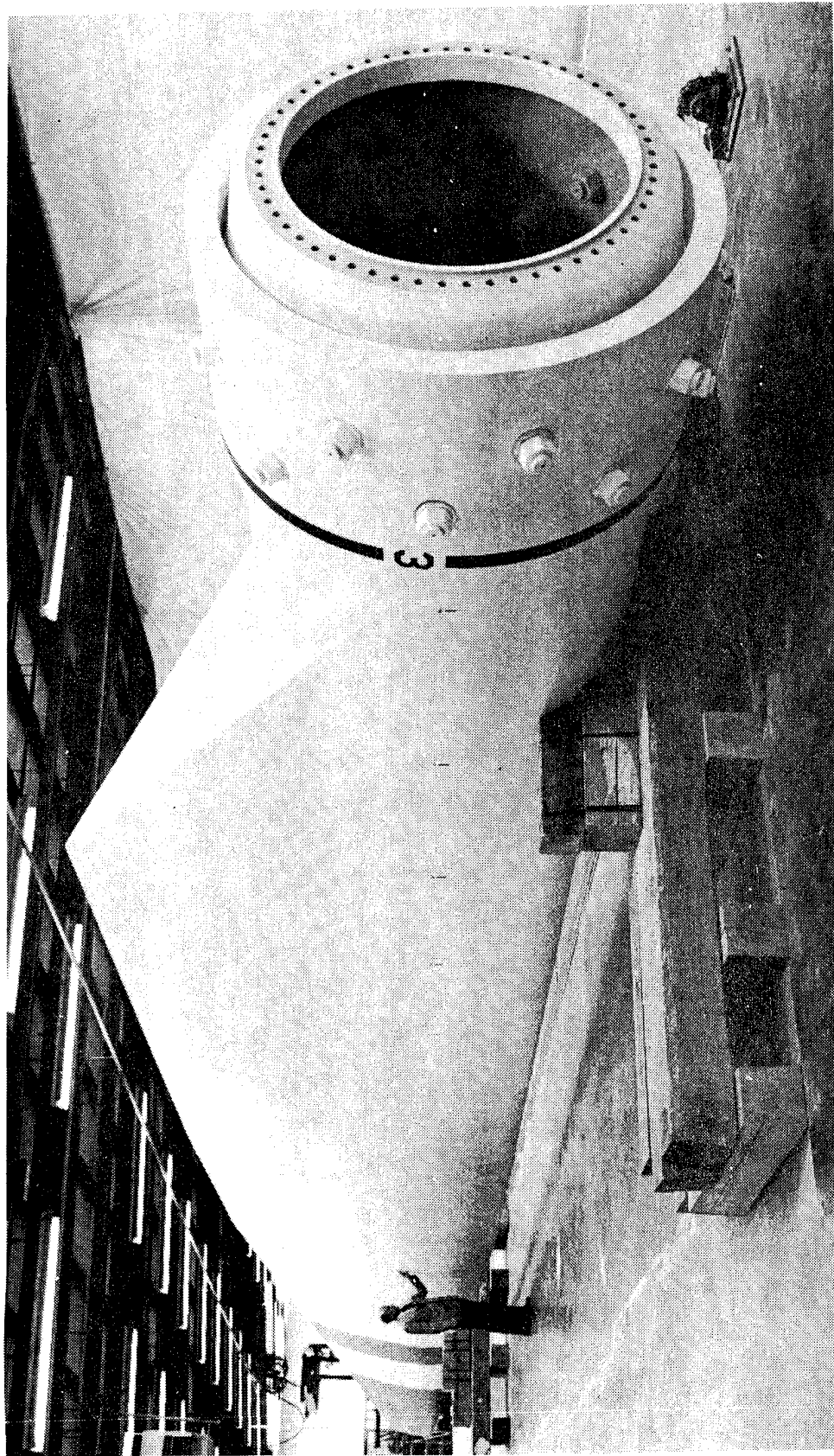

Figure 1. Mod-1 Composite Blade.

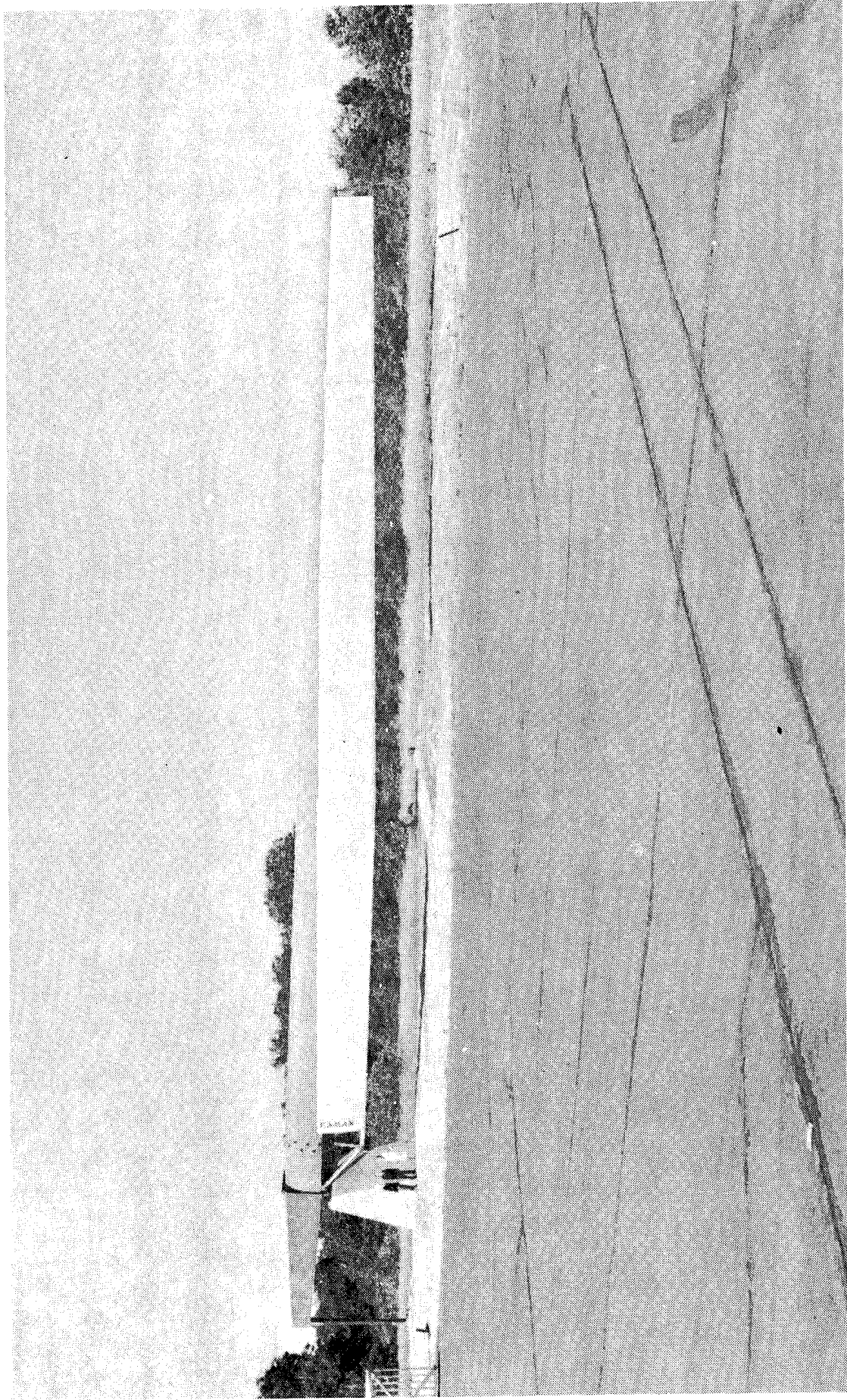
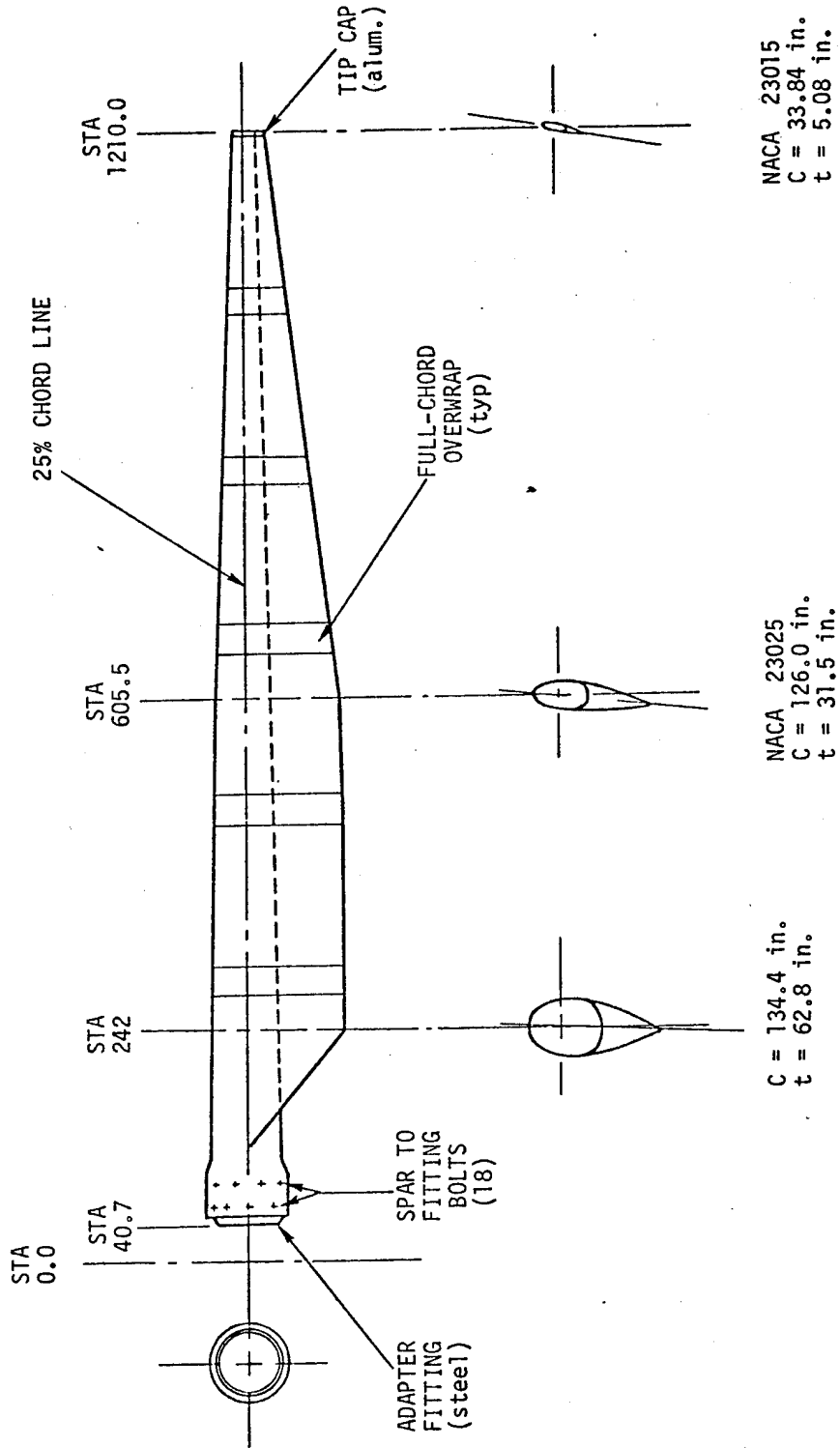

Figure 2. 150 Foot Composite Blade.



11° LINEAR TWIST, ROOT TO TIP
 23000 SERIES AIRFOIL
 WEIGHT WITH ADAPTER: 26,846 LB.

Figure 3. Planform, Mod-1 Composite Blade.

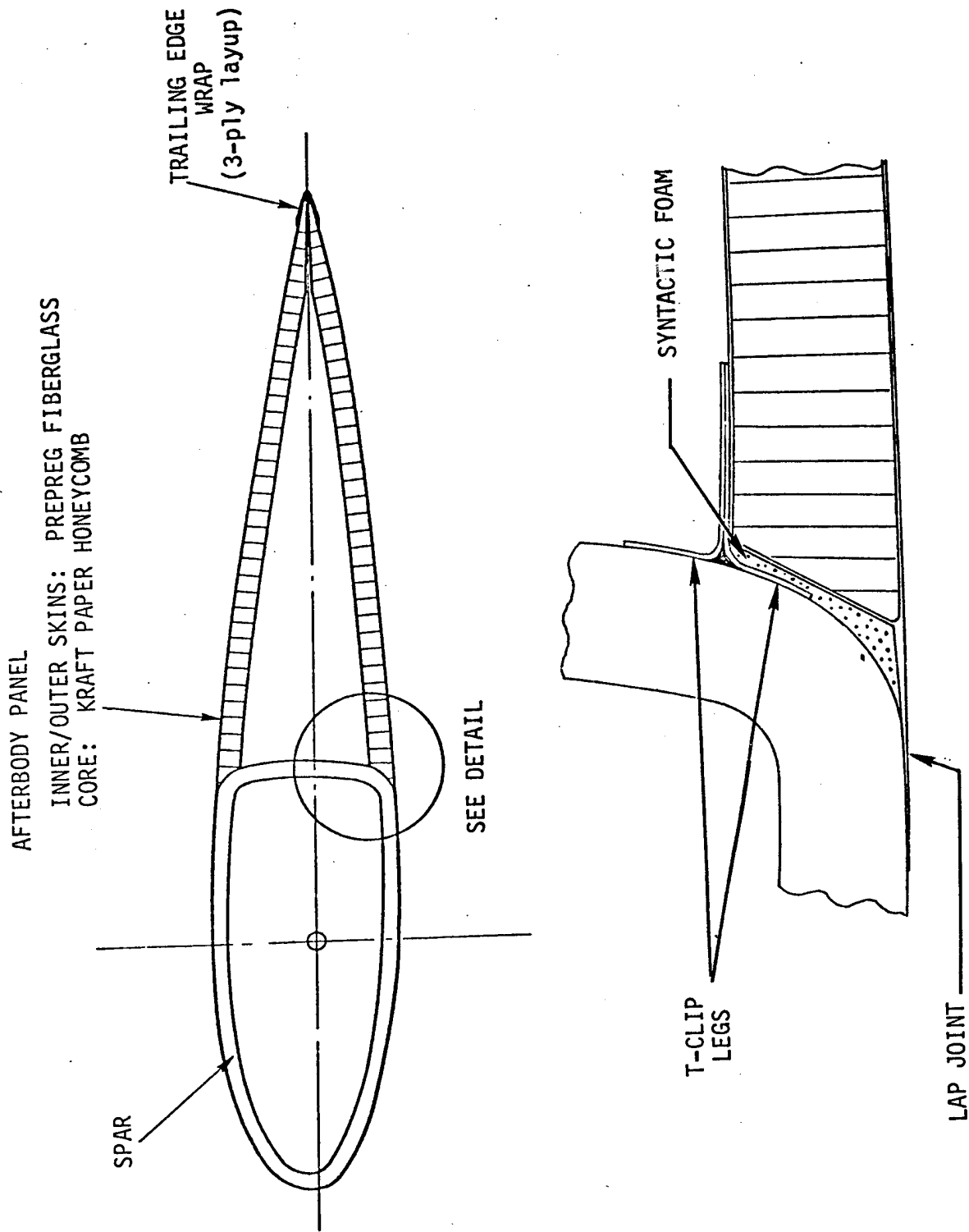

Figure 4. Cross Section, Mod-1 Blade

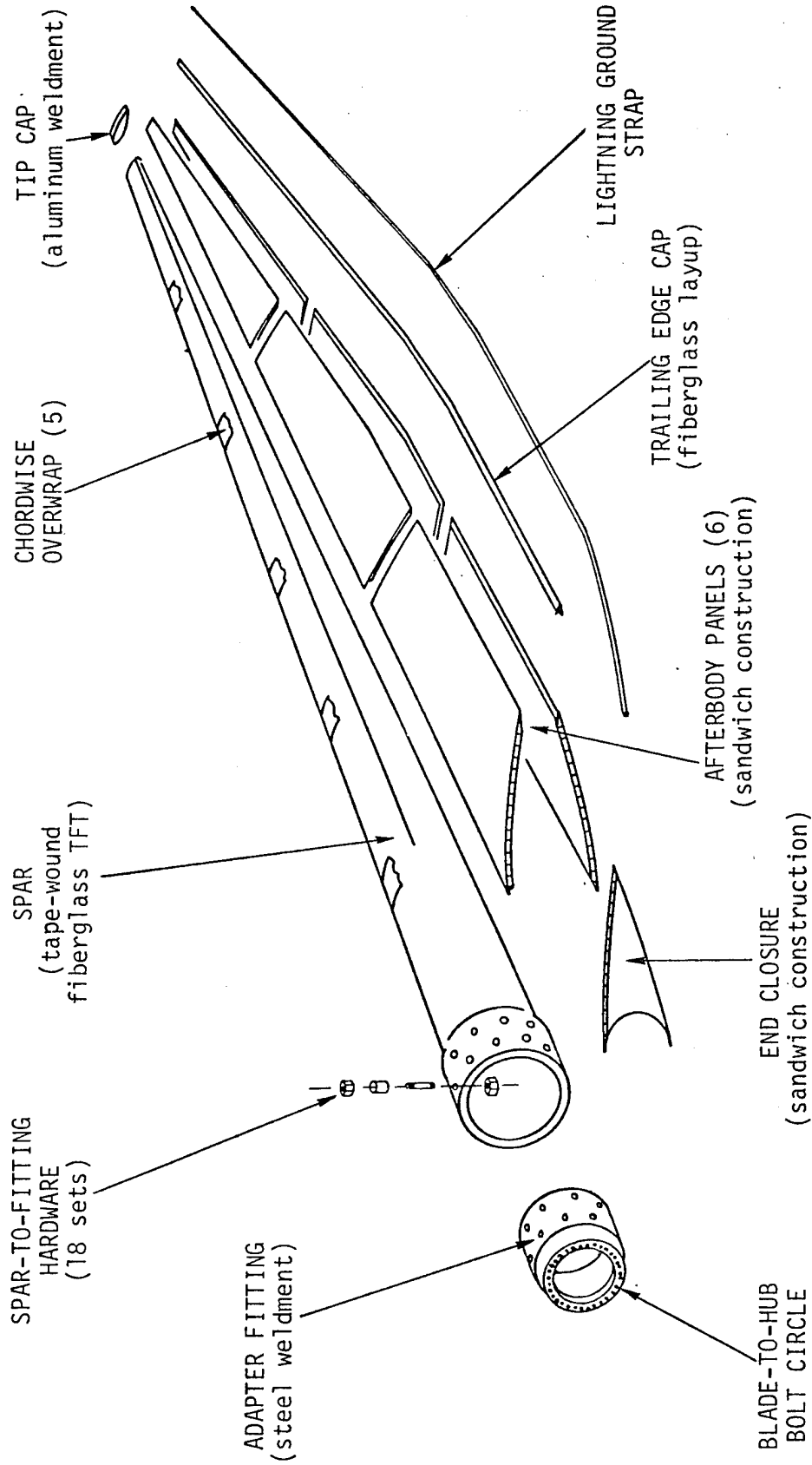

Figure 5. Exploded View

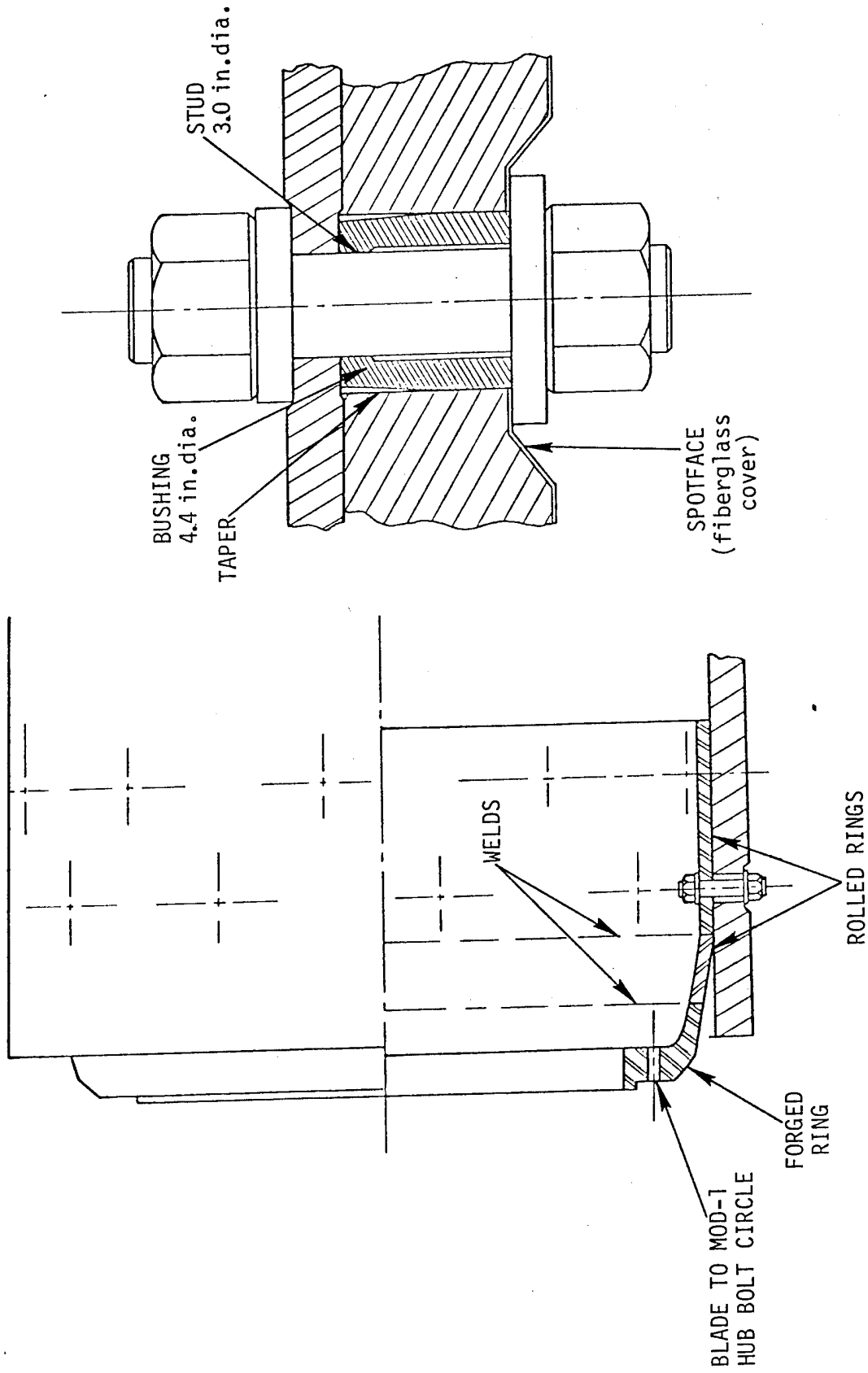

Figure 6. Adapter Fitting

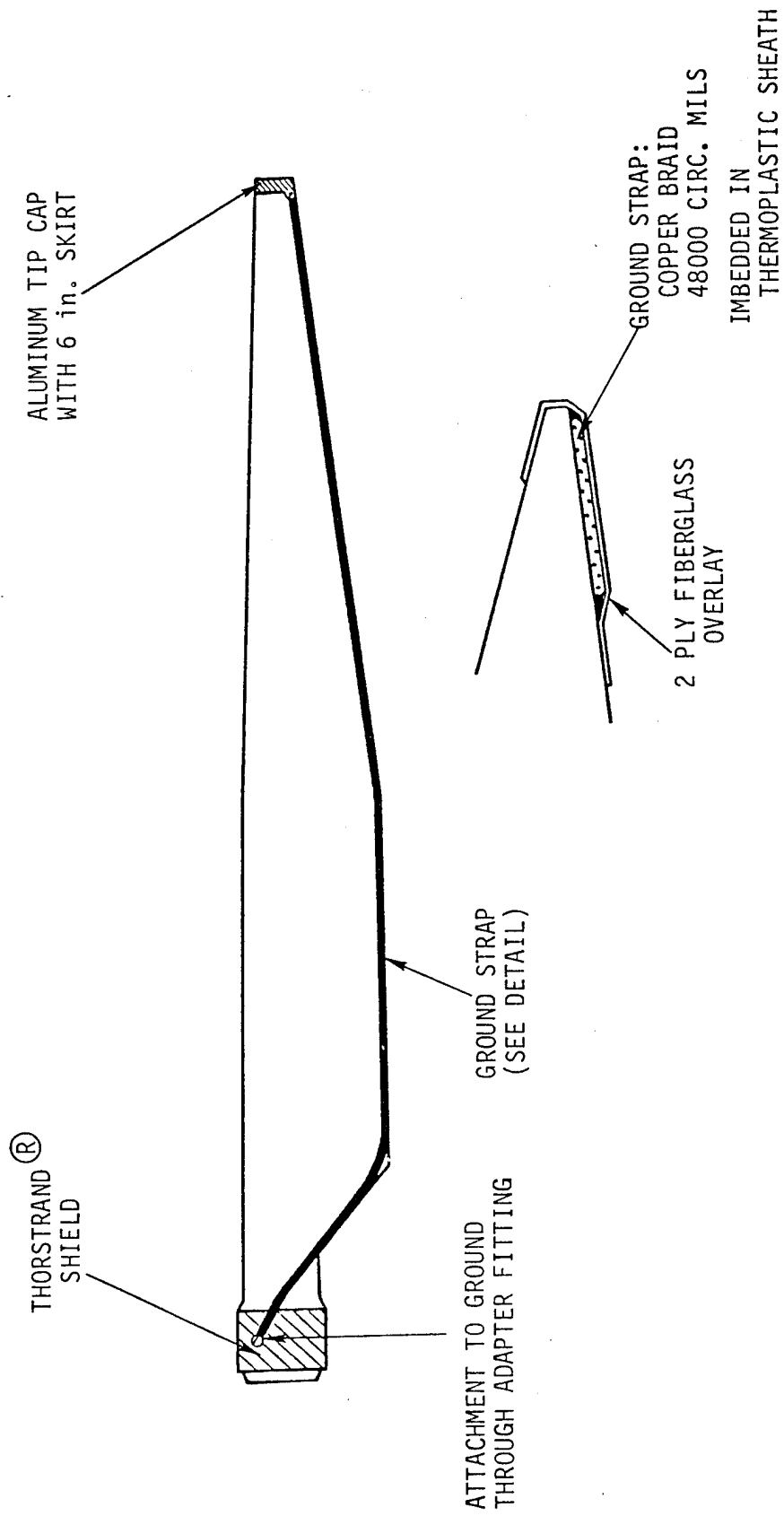

Figure 7. Lightning Protection System.

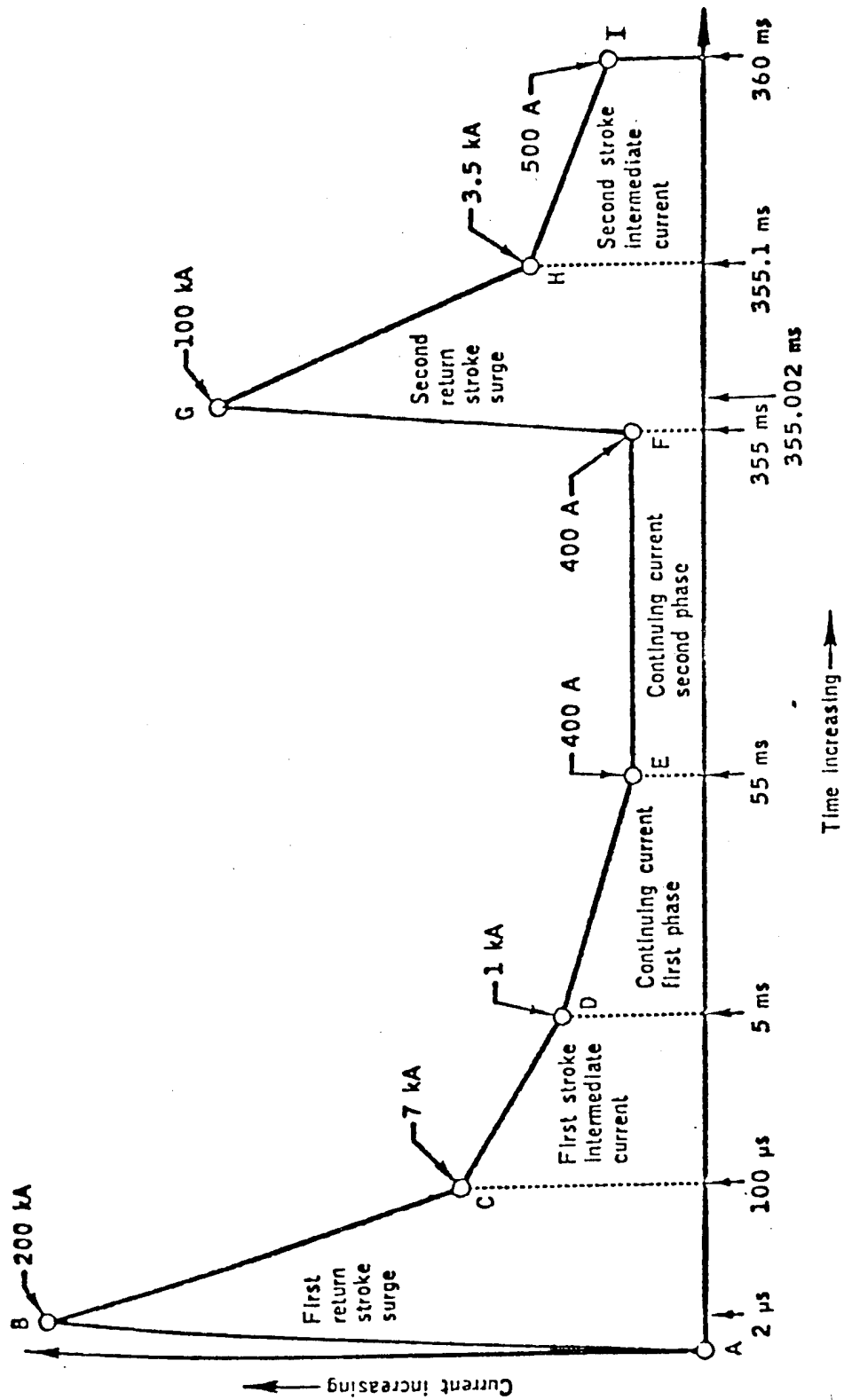

Figure 8. NASA Lightning Model

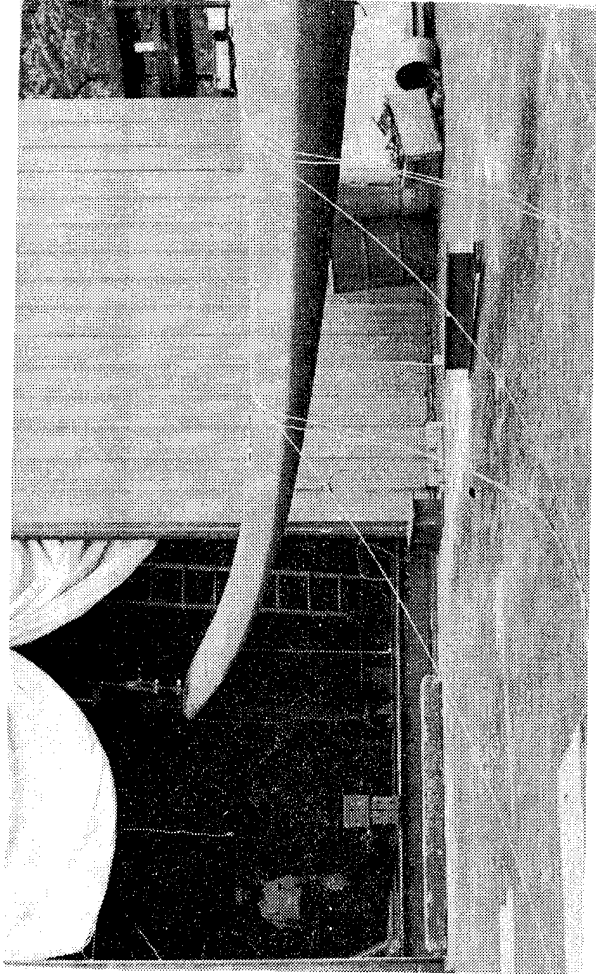
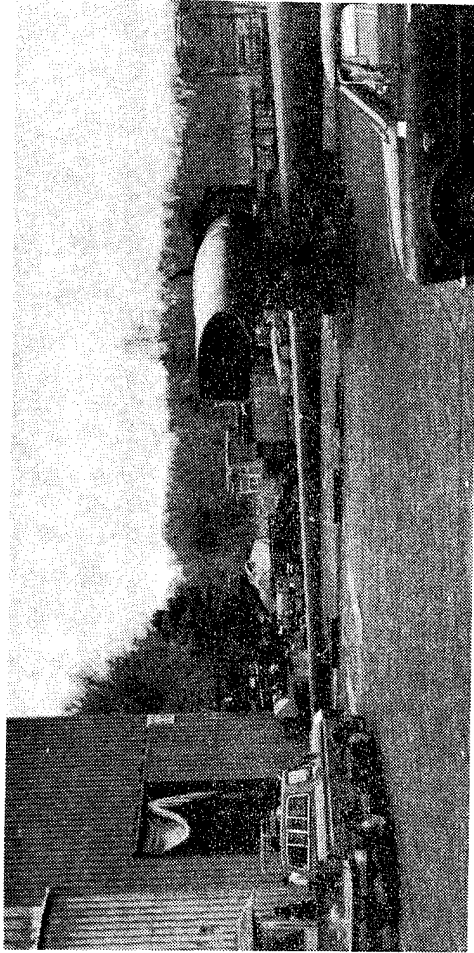

Figure 9. Mod-1 Spar Bending Test.

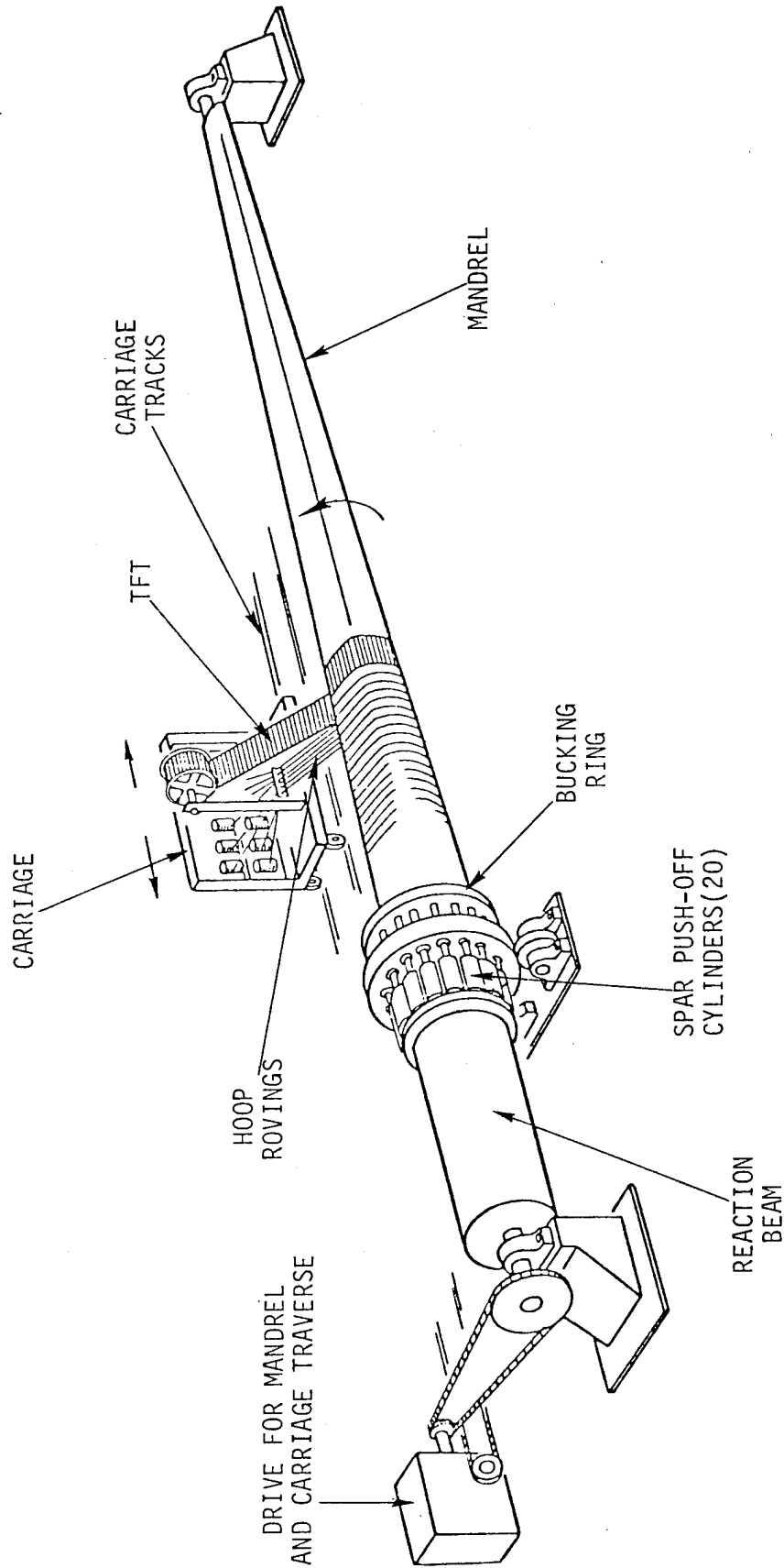

Figure 10. Spar Winding System

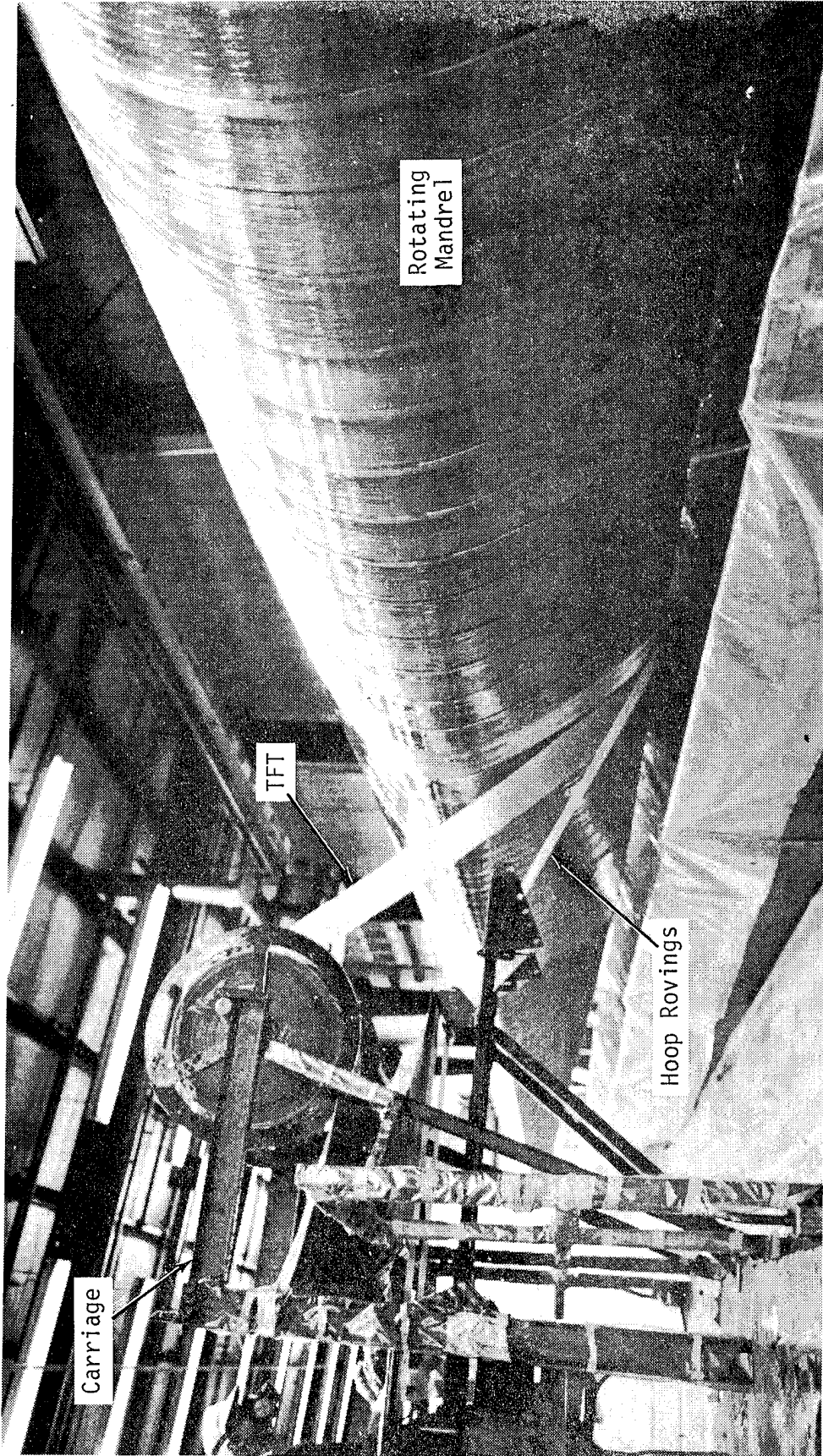

Figure 11. Spar Winding in Progress.

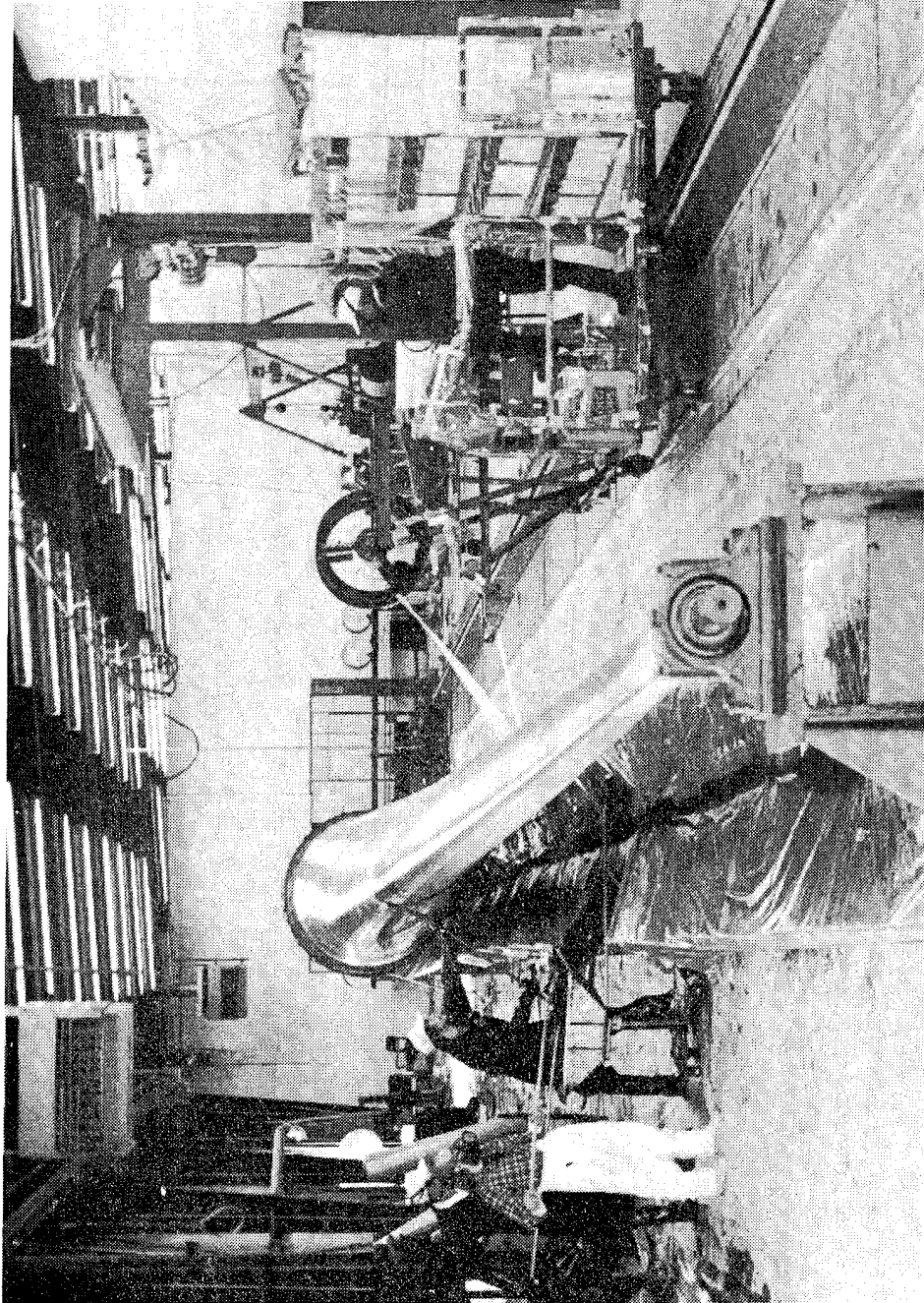

Figure 12. Manual Resin Application and Rolling.

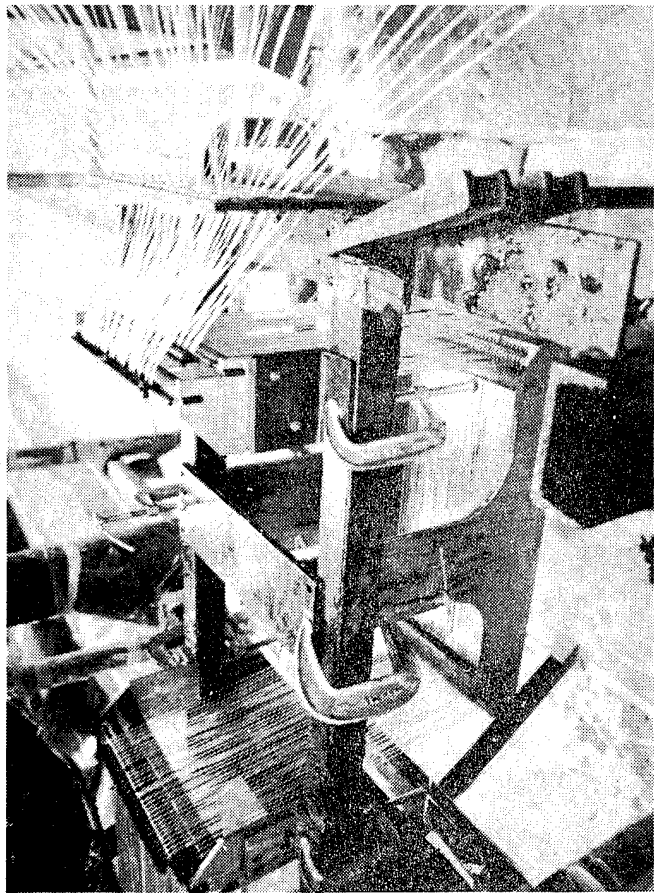

Figure 13. Feed System for Hoop Rovings.

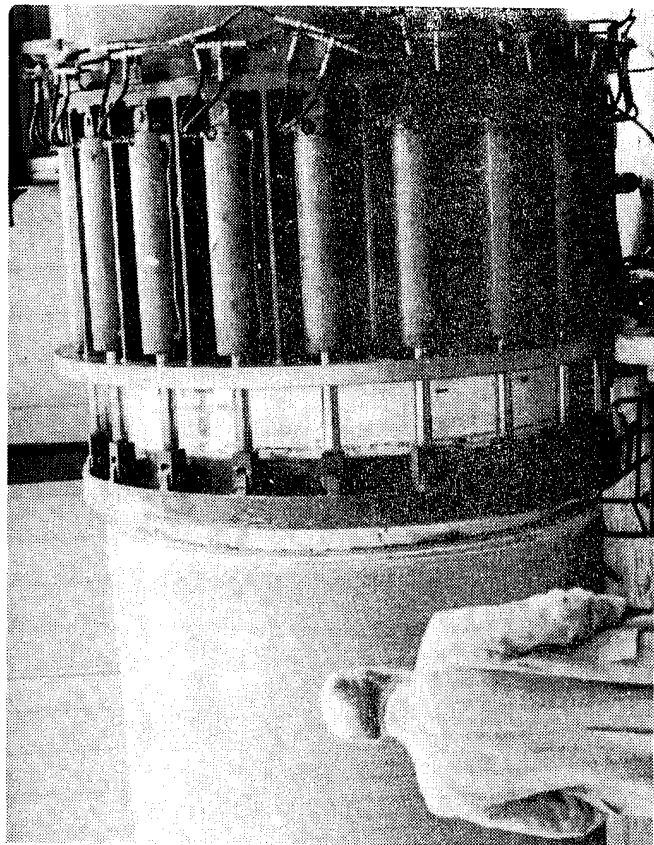

Figure 14. Removal of Spar from Mandrel.

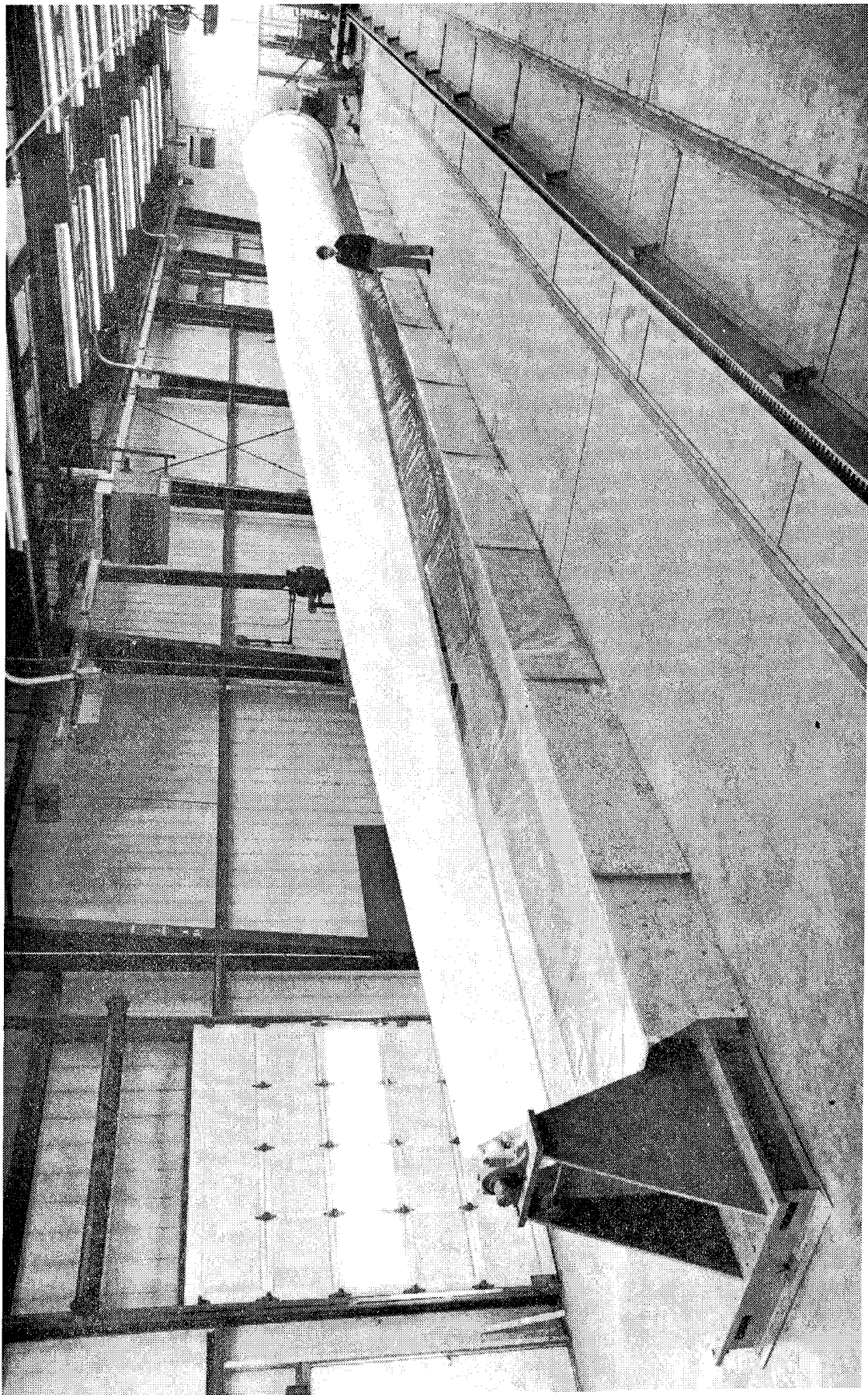

Figure 15. Spar Winding Mandrel.

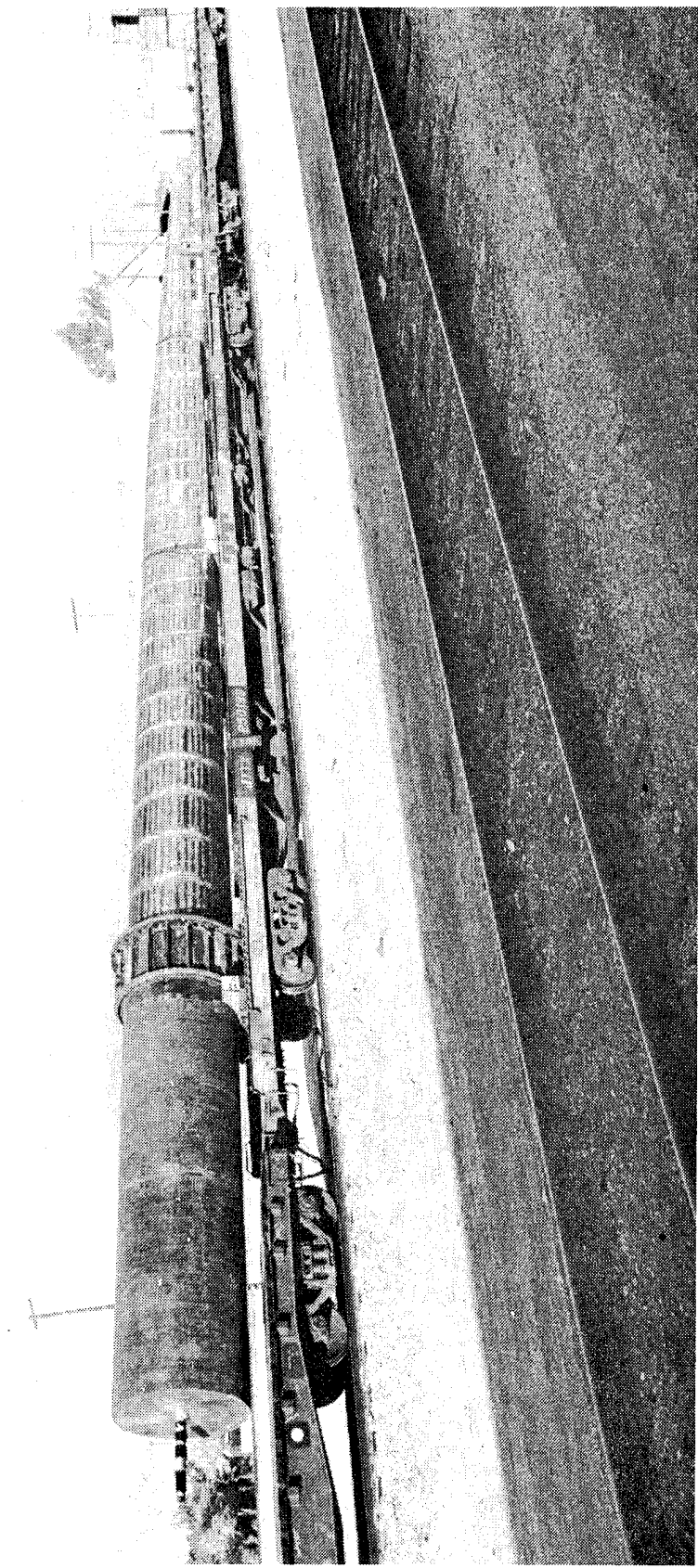

Figure 16. Transportation of 130 ft. Mandrel by Rail.

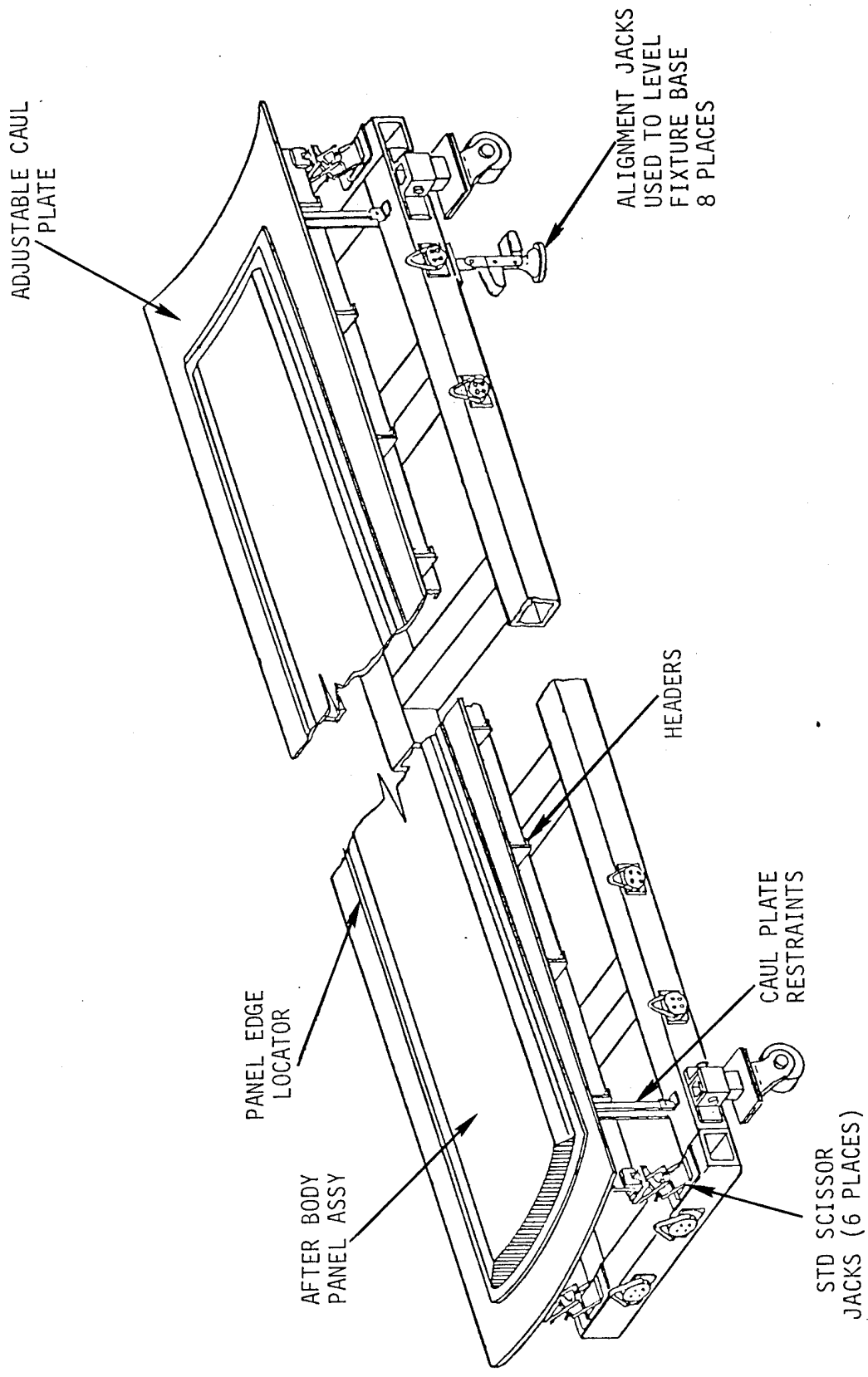
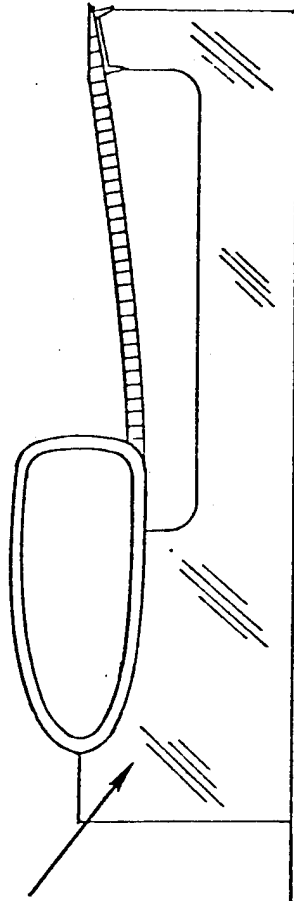

Figure 17. Afterbody Panel Bond Fixture.

Contoured Header
Header
(Wood)



Stage 1. A. Panel Dry Fit
B. T-Clip Installation

Steel Frame
(Reacts Hose Loads)

Pneumatic Hoses

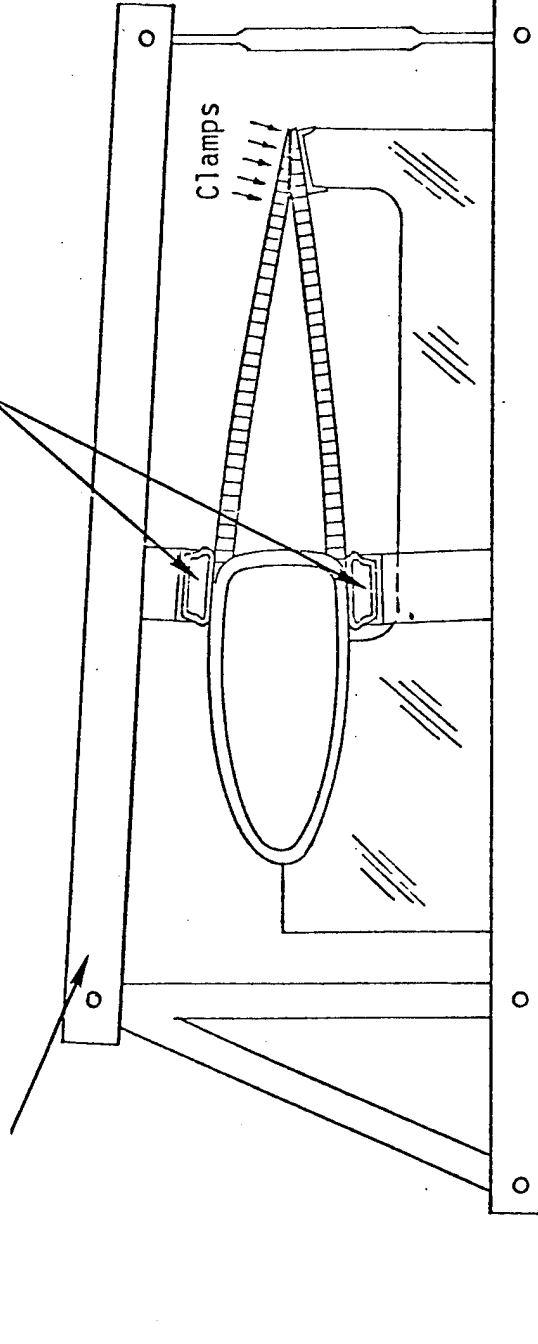

Stage 2: A. Panel to Spar Bond
B. Trailing Edge Bond

Figure 18. Afterbody Installation Fixture.

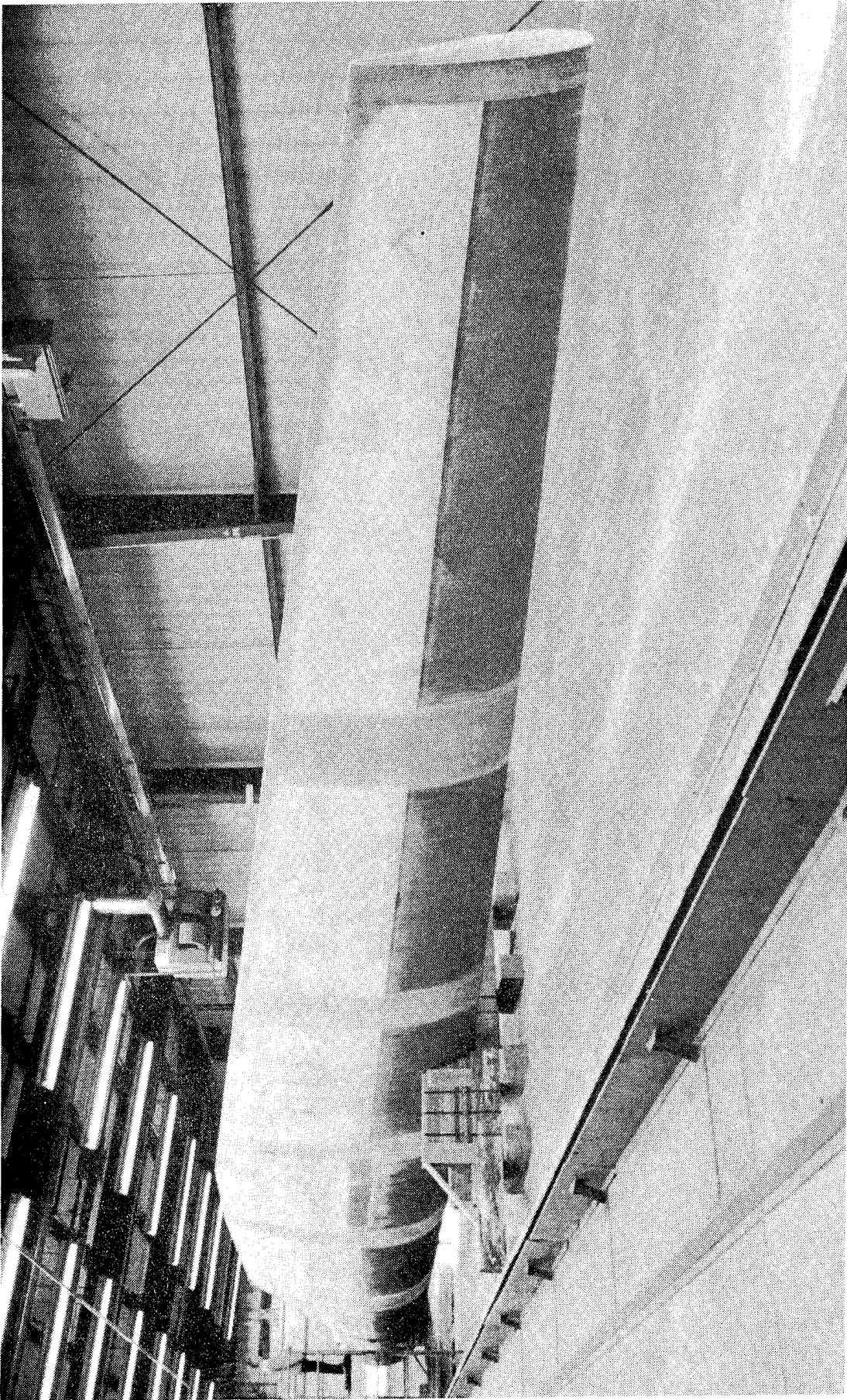

Figure 19. Five Chordwise Overwraps on Unpainted Blade.

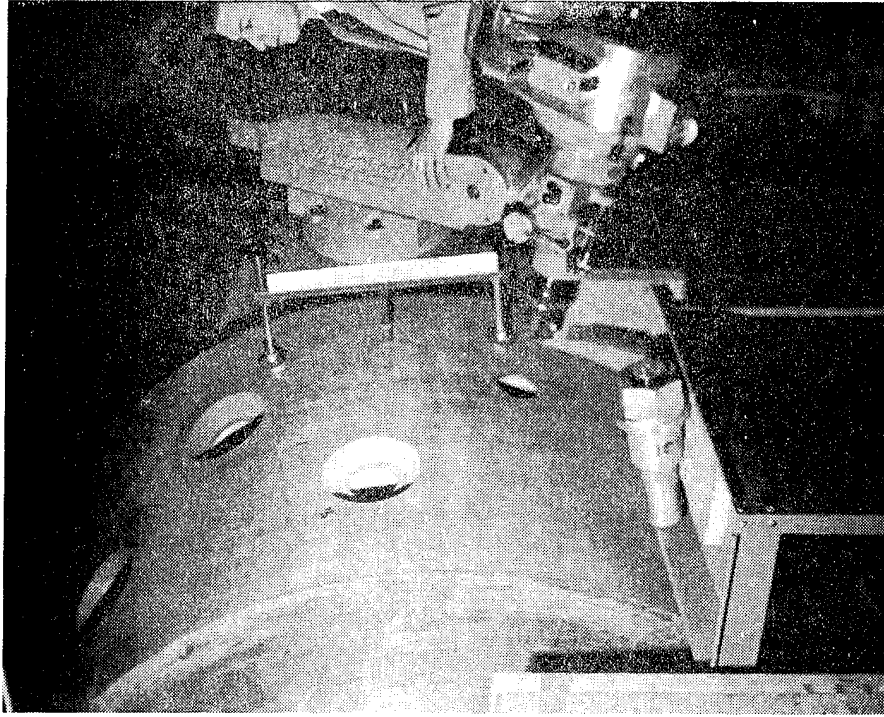

Figure 21. Set-up for Boring Spar-to-Adapter Holes.



Figure 20. Finished Adapter Fitting.

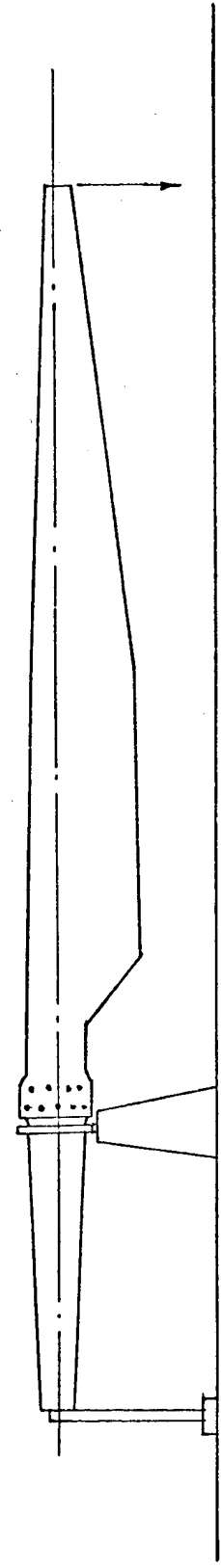
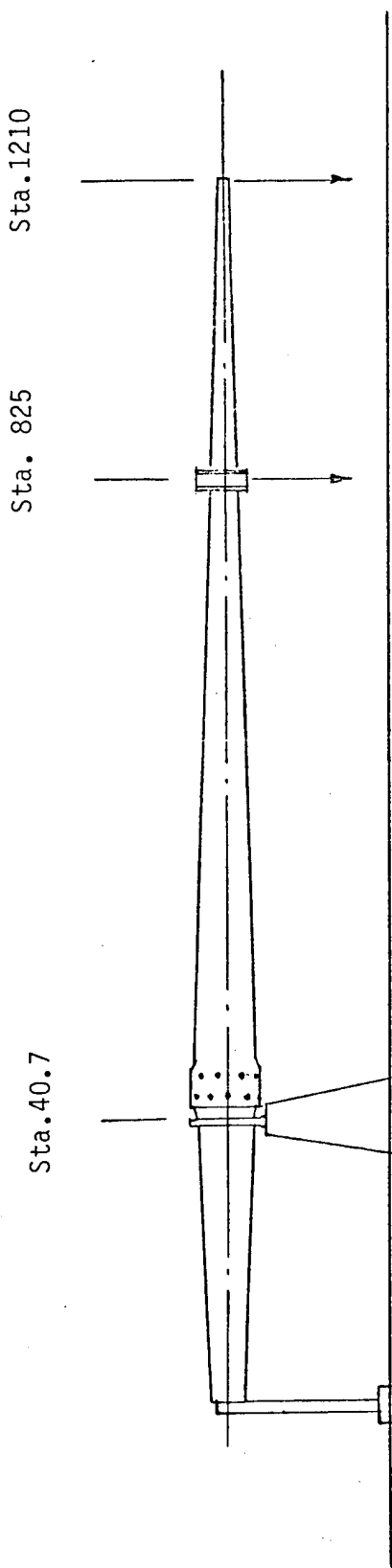

Figure 22. Bending Proof-Test Set Up.

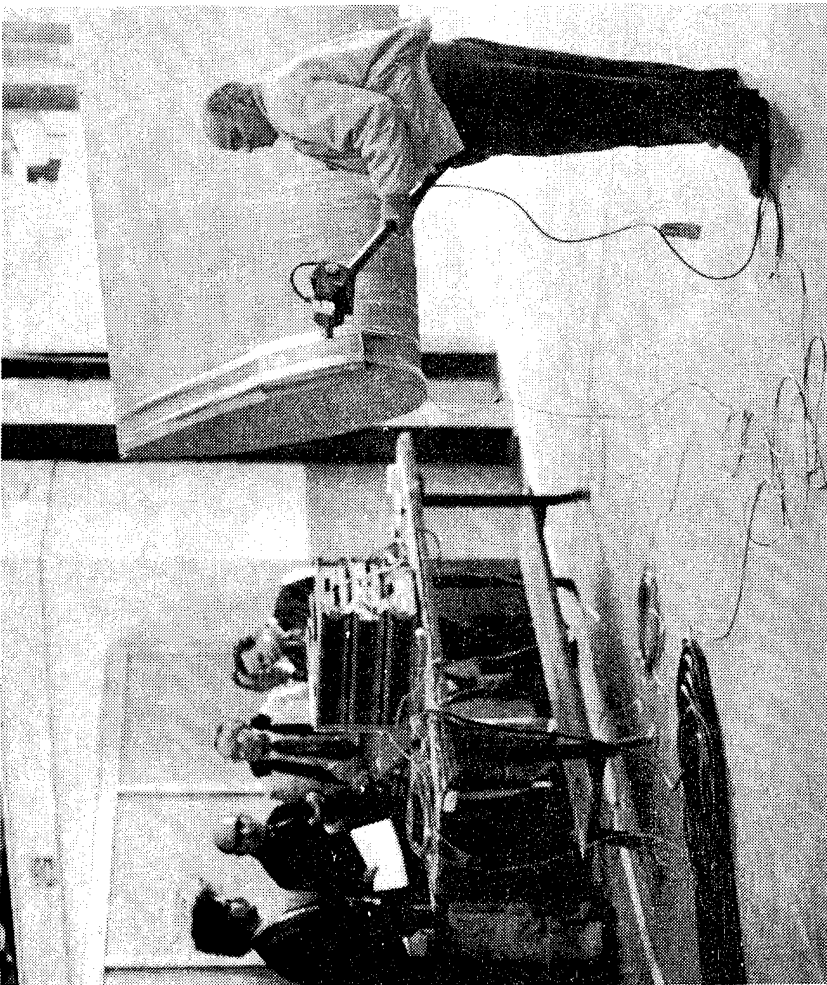
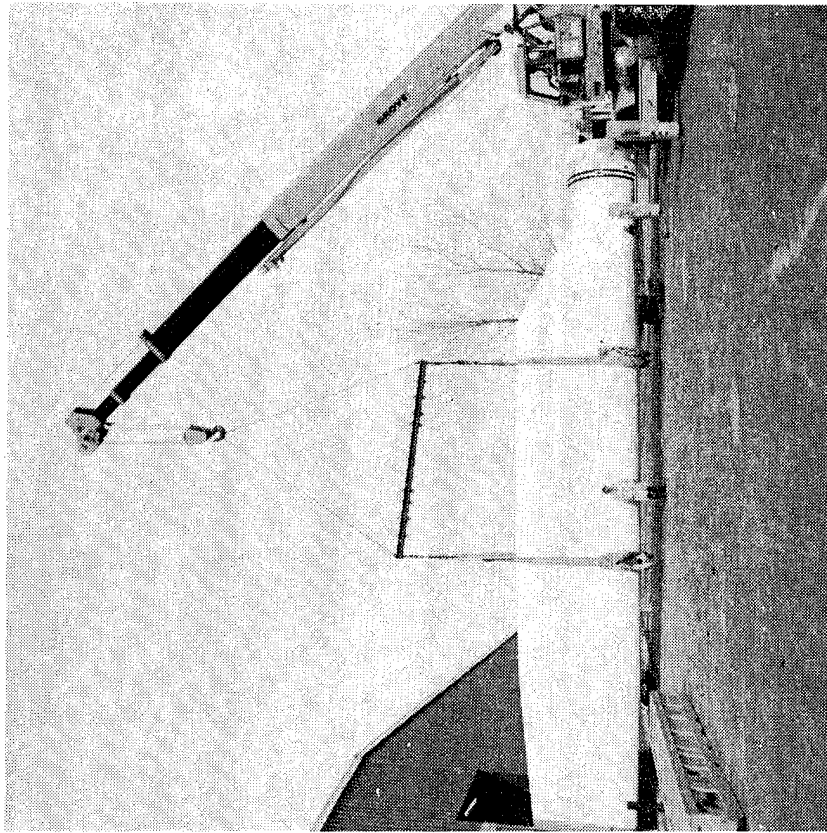

Figure 23. Free-Free Natural Frequency Check.

APPENDIX

SPECIFICATION, NASA CONTRACT DEN3-131

DATED 4 JUNE 1979

AND AMENDMENT OF 21 JULY 1980

EXHIBIT B
SPECIFICATION

1.0 SCOPE

This specification defines the technical requirements for the rotor blades to be constructed for the Mod-1 Wind Turbine Generator (WTG).

2.0 APPLICABLE DOCUMENTS

The following documents form a part of this specification to the extent specified herein. The issue in effect on date of this contract shall apply.

MIL-HDBK-5B Metallic Materials and Elements for Aerospace Vehicle Structures
GE 132D6479 September 19, 1977 Blade MOD-1 WTG Interface Dwg.
ASME Boiler and Pressure Code, Section IX

3.0 REQUIREMENTS

Requirements for individual rotor blades shall be as specified herein.

3.1 CONFIGURATION

The blades as fabricated shall conform to the interface requirements as defined in drawing No. 276-10509 and subsequent paragraphs of this specification.

3.2 WEIGHT AND C.G.

3.2.1 Weight

The weight of the blade including balance weights shall be 20,000 lbs maximum. Weight variance from blade to blade shall be within $\pm 1\%$.

3.2.2 Center of Gravity

The spanwise static moment of each blade about the center of rotation shall be achieved with tip weights to be within 467 ft.-lbs. of the design value. The design value shall be the nominal calculated spanwise moment plus three times the expected standard deviation of spanwise moment. The tip weights shall be installed at two positions chordwise approximately equally spaced about the quarter chord position and at least 4" from it. Provisions shall be made for adding or deleting blade tip weights, at the same locations as above, in 40# increments up to 500# maximum for operational dynamic tuning. The blade position for weight installation or removal is 6 o'clock. The blade chordwise center of gravity shall be no further aft than 35% chord at the blade spanwise c.g. station. Blade to blade variations in the chordwise center of gravity position shall not exceed 0.30 inches. The nominal blade elastic axis shall be located at the $30\% \pm 5\%$ chord point.

3.3 SEALING AND CORROSION PROTECTION

All metal parts of the blade shall be primed for corrosion protection with appropriate primers for the metal parts chosen. The exterior surface of the blade shall be painted. The exterior skin of the spar shall be sealed to preclude entrance of moisture in order to inhibit entrance of moisture. The trailing edge portion of the blade shall contain no open holes or cracks. Provisions of condensed water shall be made at the blade tip.

3.4 MATERIALS AND SURFACE CONDITION

3.4.1 Materials

The Blade shall be composite fiberglass construction with a steel root end adapter. Material shall be similar to those developed for the 150 foot blade (NAS3-20600).

3.4.2 Material Allowable Stresses

A prototype spar shall be fabricated on the production tooling employing production blade shop procedures for fabrication for the following verification tests:

1. Specimen tests
2. Buckling and/or crippling test

The Purpose of the above tests is to establish fiberglass material allowable stresses on a production type specimen. Allowable stresses developed on the 150 foot blade program shall be adjusted in accordance with the results of the above tests. This testing shall be accomplished prior to fabrication of the production articles.

3.4.3 Surface Condition

Blade contour waviness, with respect to variations from the chord line, may vary as shown in the table below:

Chordwise distance	Maximum Permissible Contour Variation from Chord Line
0 - 30% chord	± 0.15% C (both surfaces)
30 - 100% chord	± 0.30% C (both surfaces)

TABLE 3.4.2-1 PERMISSIBLE CONTOUR WAVINESS

The quarter wave length for the variations noted above shall not be less than 10% chord. The reference line for spanwise contour waviness shall be the lines perpendicular to the bolting circle formed by the intersection of the 25% chord with the chord plane. The intersection of the 25% chord with the chord plane of each section shall be the reference point of that section. The reference point for the tip shall be within 2 inches of the reference line and for Station 301 within 1 inch. Intermediate stations shall be within a cone 1 inch diameter

at Station 301 and a 2 inch diameter at the tip and within a cone of 1 inch diameter at Station 301 with an apex at Station 40.7. Appropriate points on the blade surface or on the assembly tool may be used for straightness measurements. If the assembly tool is used for support during measurement, it shall apply no forces to the blade during inspection except support forces.

3.5 LIFTING, HANDLING AND SHIPPING

3.5.1 Lifting

The blade design shall incorporate provisions for lifting of the finished blade in a horizontal attitude from the ground upward. Four blade attitude positions are required:

- 1) leading edge up
- 2) leading edge down
- 3) leading edge to right
- 4) leading edge to left

The above may be accomplished with the blade itself or by means of a fixture to be available in the field. The lift and support points and safety securing items shall be specified on detailed drawings.

3.5.2 Handling and Shipping

The blade shall have provisions for being handled and cradled for shipping. Shipping environments shall include those encountered by rail and highway transportation.

3.6 INTERFACE

3.6.1 Mechanical

The blade mechanical interface is defined on drawing GE 132D6479. At the blade/hub interface (Sta 40.70) the blade shall distribute the loads such that the load at any bolt shall not exceed the theoretical rigid condition loading assumption by more than a factor of 1.3.

3.6.2 Other

The lifting and handling interface drawing is to be contractor supplied.

3.7 Drawings and Specifications

The contractor shall prepare all drawings and specifications required for the fabrication, inspection and delivery of the blades for the MOD-1 Wind Turbine. Three (3) prints and one (1) reproducible copy of all assembly and detail drawings shall

be forwarded to NASA-LeRC five (5) working days after their release. All changes to these drawings that affect the performance, interface, safety or reliability shall be approved by NASA-LeRC. All changed drawings shall be forwarded to NASA-LeRC within five (5) working days.

3.7.1 Reserved

3.7.2 Reserved

3.7.3 Final Drawings

If the final drawings contain references to specifications, procedures, manuals and processes that are company proprietary and/or not available through conventional literature sources, complete definitions for each specification, procedure, manual and process shall be delivered to NASA-LeRC in reproducible form.

3.8 BLADE IDENTIFICATION

The blades shall be individually marked on the transition interface ring for identification.

3.9 GENERAL DESIGN

3.9.1 Summary of Technical Requirements/Design Characteristics

The blade shall be designed for a wind turbine having the following characteristics:

Rated Rotor Power-----	2200 kW
Rated Electrical Output-----	2000 kW
* Rated Wind Speed-----	25.5 mph
* Cut-Out Wind Speed-----	35 mph
** Maximum Design Wind Speed-----	150 mph
* Annual Average Wind Speed-----	18 mph
Rotors per Tower-----	1
Location of Rotor-----	Downwind of tower
Direction of Rotation-----	cc(looking upwind)
Rotation Rate (approximate)-----	35 rpm
Blade per Rotor-----	2
Cone Angle-----	90
Rotor Diameter (approximate)-----	200 ft

* Wind Velocities at 30 feet (9 meters) Elevation.
 ** Wind Velocity at Shaft CL - Assume no wind shear

Airfoil Section-----	NACA 230xx
Solidity-----	4.7%
Blade Twist-----	11°
Tower-----	131 ft.
Blade Tip to Ground Clearance-----	40 ft.
Hub Height-----	140 ft.
Yaw Rate-----	.25°/sec.
Blade Pitch Change Rate-----	*
System Life-----	30 yrs.

Note: English dimensions are exact and the metric equivalents are approximate.

3.9:2 General Design Requirements

3.9.2.1 Design Life - The blade shall be designed for a service life of 30 years, and may include periodic maintenance.

3.9.2.2 Materials, Parts and Components - The technology used shall be based on the 150 foot blade.

3.9.2.3 Environmental - The blade design shall incorporate provision for operation in snow, rain, lightning, hail, icing conditions, salt water vapors, wind-blown sand and dust, solar radiation, and in temperature extremes of -35°C (-31°F) to 49°C (120°F).

3.9.3 SPECIFIC REQUIREMENTS

3.9.3.1 Overall Requirements

3.9.3.1.1 The blade design shall make provisions for proper balancing.

3.9.3.1.2 The blade shall be designed to allow installation of strain gage instrumentation and wiring.

3.9.3.2 Design Conditions

The blades shall be designed for a life of 30 years for the conditions and loadings described in paragraphs 3.9.3.2.1 and 3.9.3.2.3.

3.9.3.2.1 Design Loads

The blades shall be designed to the loads specified in paragraphs 3.9.3.2.1.1, .2, .3 and 3.9.3.2.1.5. The limit loads are defined in terms of the flapwise and chordwise moments as a function of radius for the mass distribution used. The development of the loads are an iterative process with final loads determined from the final design geometry and mass properties. Azimuthal cyclic variations in the blade loading occurs as shown in Figures 1 and 2. Combinations of chordwise and flapwise moments shall consider peak loading of the combined spectrum of these figures such that maximum stresses at selected points in the cross

*140°/sec for .8 sec decreasing to 30°/sec. Normal pitch change 2-30°/sec.

section are determined. Axial loading due to rotation about the center of rotation at a constant speed of 35 RPM for the fatigue and gust conditions, 43.8 RPM for the emergency feather condition and 0 RPM for the hurricane condition shall be included in the respective loading conditions. Instantaneous load is defined as the mean \pm the cyclic load. Sign convention for the applied loads is shown in Figure 15.

3.9.3.2.1.1 Fatigue Loads

Fatigue loading occurs during all operating wind velocities from start up, 11 MPH, through cut out, 35 MPH. The total number of stress cycles is 4.35×10^8 . The fatigue loads peak for the 35 MPH wind and 24.8 MPH wind conditions, which therefore, define the loads to be used for the fatigue loads analysis. The nominal distributions are shown in Figures 3, 3a, 4 and 4a. For each loading direction the cyclic loads vary in magnitude about the nominal load, M_0 , as shown by the load-cycle distribution of Figures 5 and 6.

3.9.3.2.1.2 Gust Loading

The maximum blade loads resulting from severe positive and negative gusts are given in Figures 7 thru 10. These loads will be encountered infrequently.

3.9.3.2.1.3 Hurricane Loading

The maximum blade loads encountered due to hurricane winds while in a horizontally locked and feathered condition are given in Figures 11 and 12. These loads will be encountered infrequently.

3.9.3.2.1.4 Load Occurrence

Loading conditions shall be considered to fall into the following categories:

<u>Frequency of Occurrence</u>	<u>Material Strength</u>
(a) Infrequent	Proportional Limit
(b) Continuous	Combined fatigue loading considering stress-cycle relations

3.9.3.2.1.5 Emergency Feather - Overspeed

The maximum blade loads encountered due to emergency feathering are given in Figures 13 and 14. For this condition the rotor will overspeed to a maximum of 43.8 RPM. These loads will be encountered infrequently.

3.9.3.2.2 STIFFNESS DISTRIBUTION AND BLADE FREQUENCY

Non-rotating, rigidly mounted, cantilevered blade frequencies shall be:

1st Flapwise	1.17 - 1.45 Hz
1st Chordwise	2.80 - 2.98 Hz
1st Torsion	17.5 Hz

3.9.3.2.3 Lightning Considerations

Provisions shall be incorporated for a conductive path to ground in the event of repeated lightning strikes.

3.9.3.2.4 Environmental

The blade must be capable of operation in snow, rain, lightning, hail, icing conditions, salt water vapors, windblown sand and dust and in temperature extremes of -35°C (-31°F) to 49°C (120°F).

3.9.3.3 ANALYSIS

3.9.3.3.1 Structural

Adequate structural analysis shall be used to verify the design. The model description, and stress analysis shall be provided to NASA-LeRC. A buckling safety factor of 1.5 shall be used in the design of the blade.

3.9.3.3.1.1 Stress

Stress calculations shall be made using accepted engineering procedures and theories. Special factors shall be included if appropriate. The calculations shall consider the environmental factors, paragraph 3.9.3.2.4 Fatigue life shall be calculated using the technique described in paragraph 3.9.3.2.1.1.

The effects of materials and processes shall be included.

The stress levels, for type (a) loads, paragraph 3.9.3.2.1.4 are not to exceed the proportional limit of the material. Where appropriate, other more critical failure modes, e.g., crippling shall determine the stress allowable.

The analysis shall account for beams, ribs, stiffeners, and shells or plates used in the design of the blade structure. Beams, ribs, stiffeners and all highly stressed fasteners including joints, bonded or bolted, shall be analyzed for fatigue strength as well as other potentially critical design conditions.

3.9.3.3.1.2 Section Properties

The contractor shall provide the NASA Project Manager with definition of the spanwise distribution of blade mass and inertia and blade section properties (E, I, G, J, A, EI, GJ, AE, elastic axis, section CG) to show compliance with the stated requirements for the contractor's design.

3.9.3.3.1.3 Margins of Safety

Margins of safety shall be positive. Margins of safety for combined stress shall be based on the stress ratio method of Mil Handbook 5B, incorporated herein by reference and made a part hereof.

3.9.3.3.1.4 Static Strength Failure Criteria

The blade shall withstand the following:

1. Metal Parts - 1.15 times limit load without permanent set.
2. All Parts - 1.5 times limit load without fracture.

3.9.3.3.2 Dynamics

The contractor shall determine analytically the non-rotating cantilever natural frequencies for the first four flapwise modes, the first three chordwise modes and the first two torsion modes, and mode shapes to verify compliance with the blade tuning requirements of paragraph 3.9.3.2.2.

3.9.3.4 TESTS

The contractor shall submit to the NASA Project Manager and obtain approval of all applicable test plans prior to performing tests.

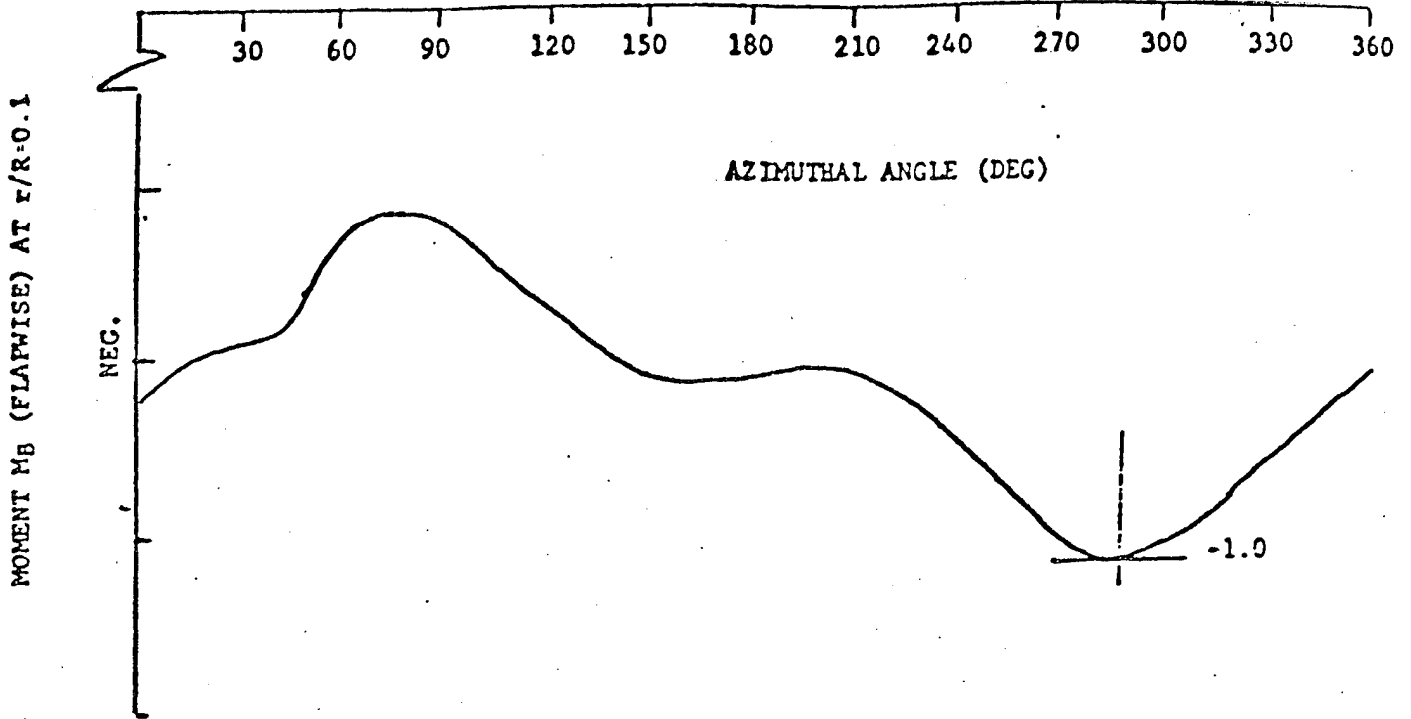

FIGURE -1 FLAPWISE MOMENT AT $r/R = 0.1$

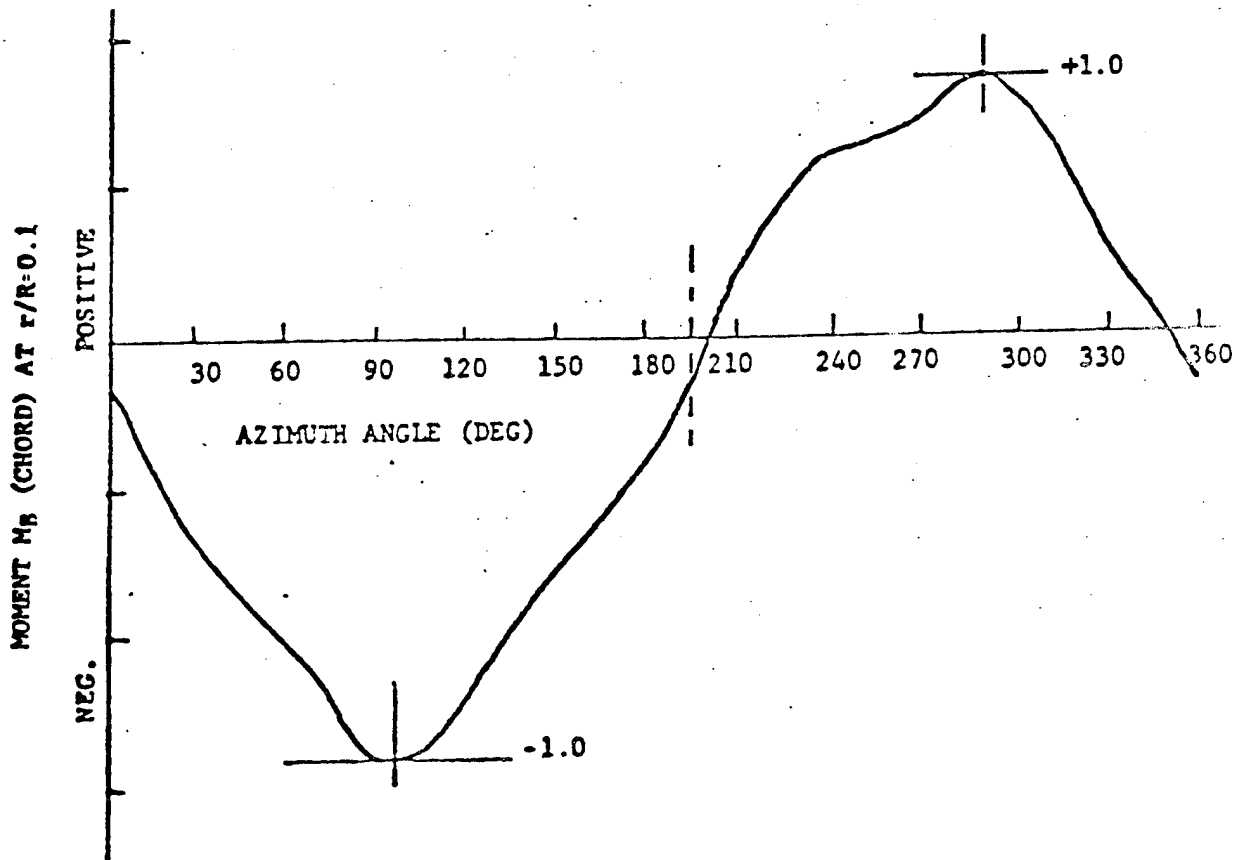

FIGURE -2 CHORDWISE MOMENT AT $r/R = 0.1$

FLAPWISE BENDING MOMENT DISTRIBUTIONS

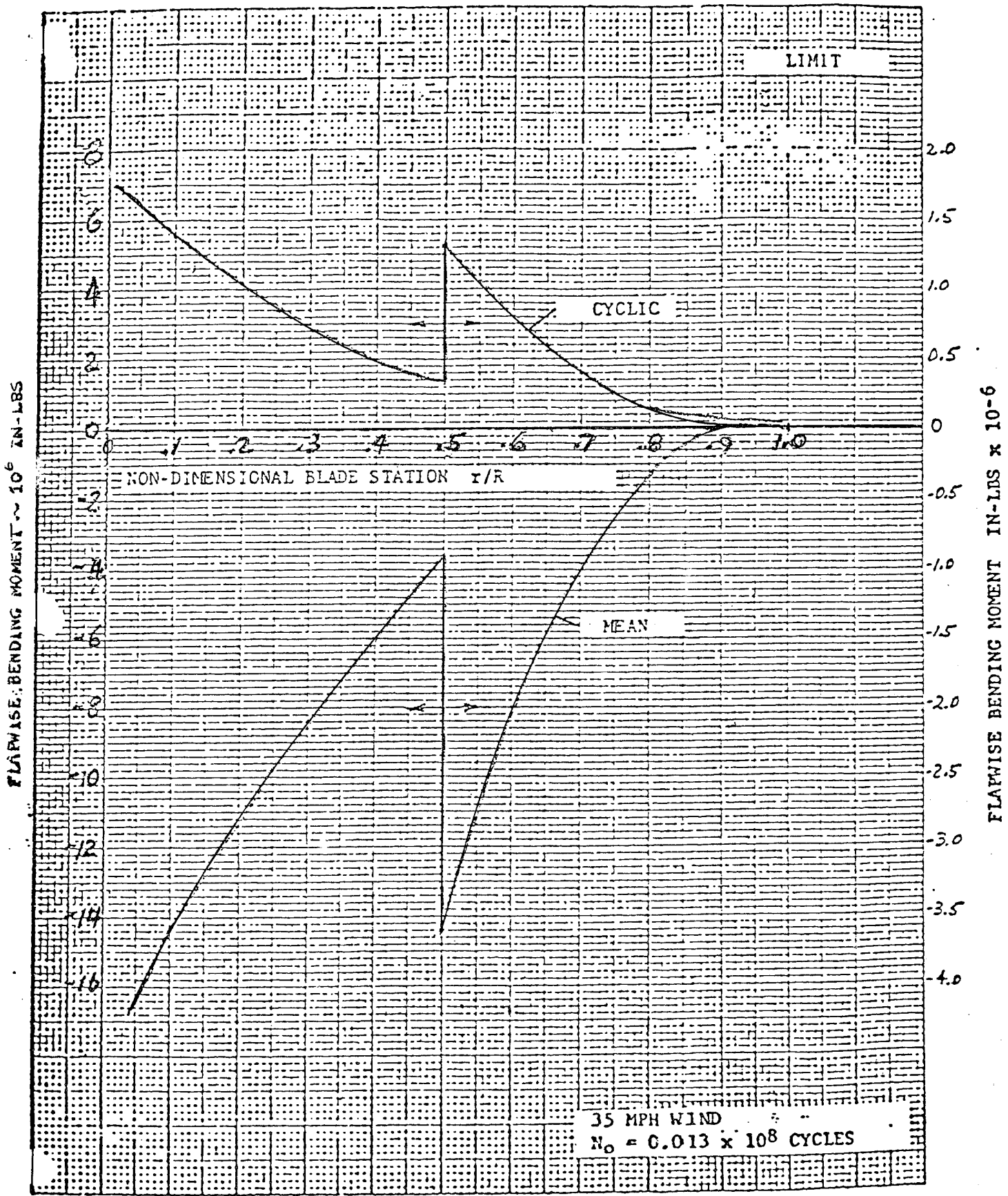

FIGURE -3

FLAPWISE BENDING MOMENT DISTRIBUTION

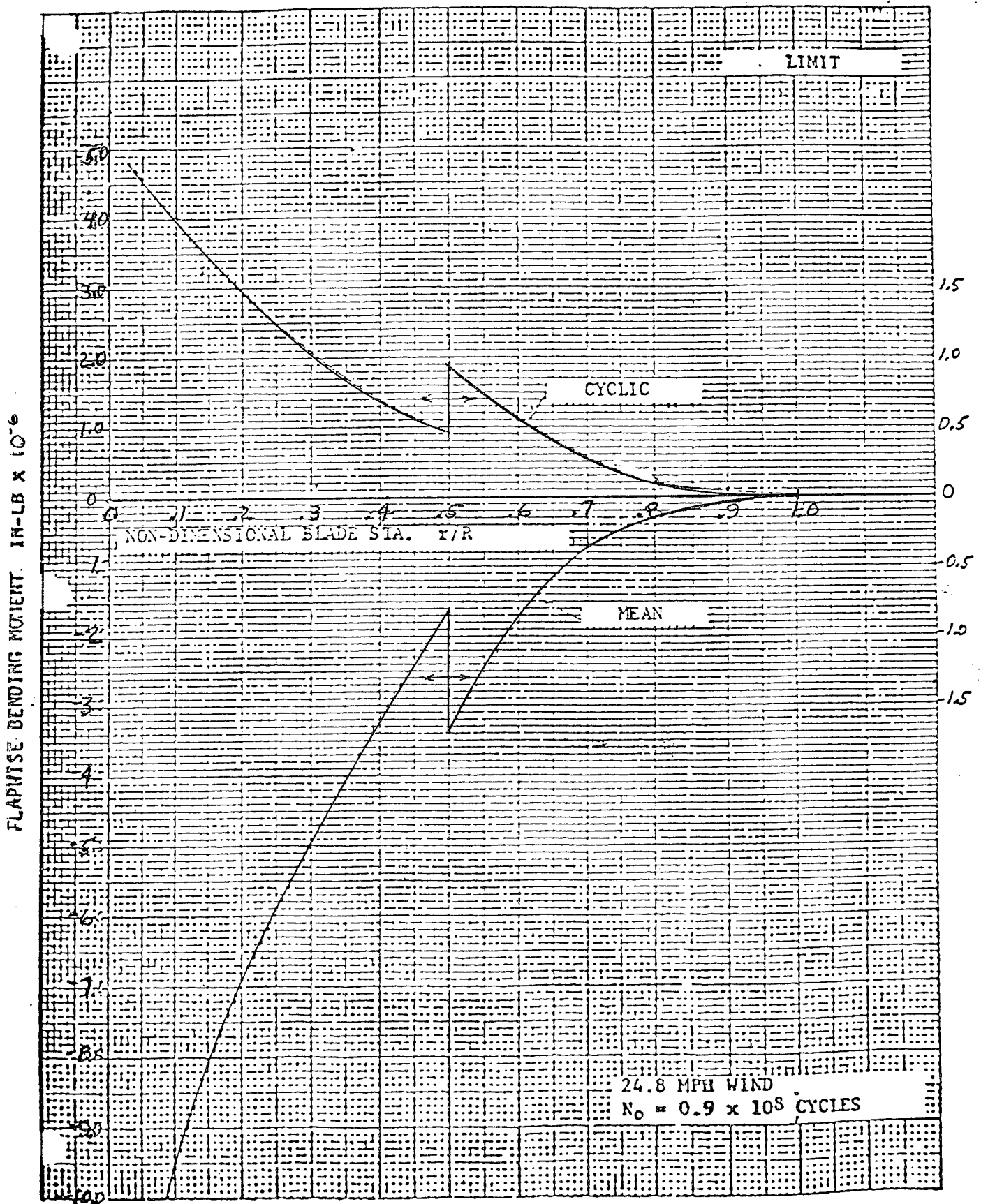

FIGURE -3a

CHORDWISE BENDING MOMENT DISTRIBUTION

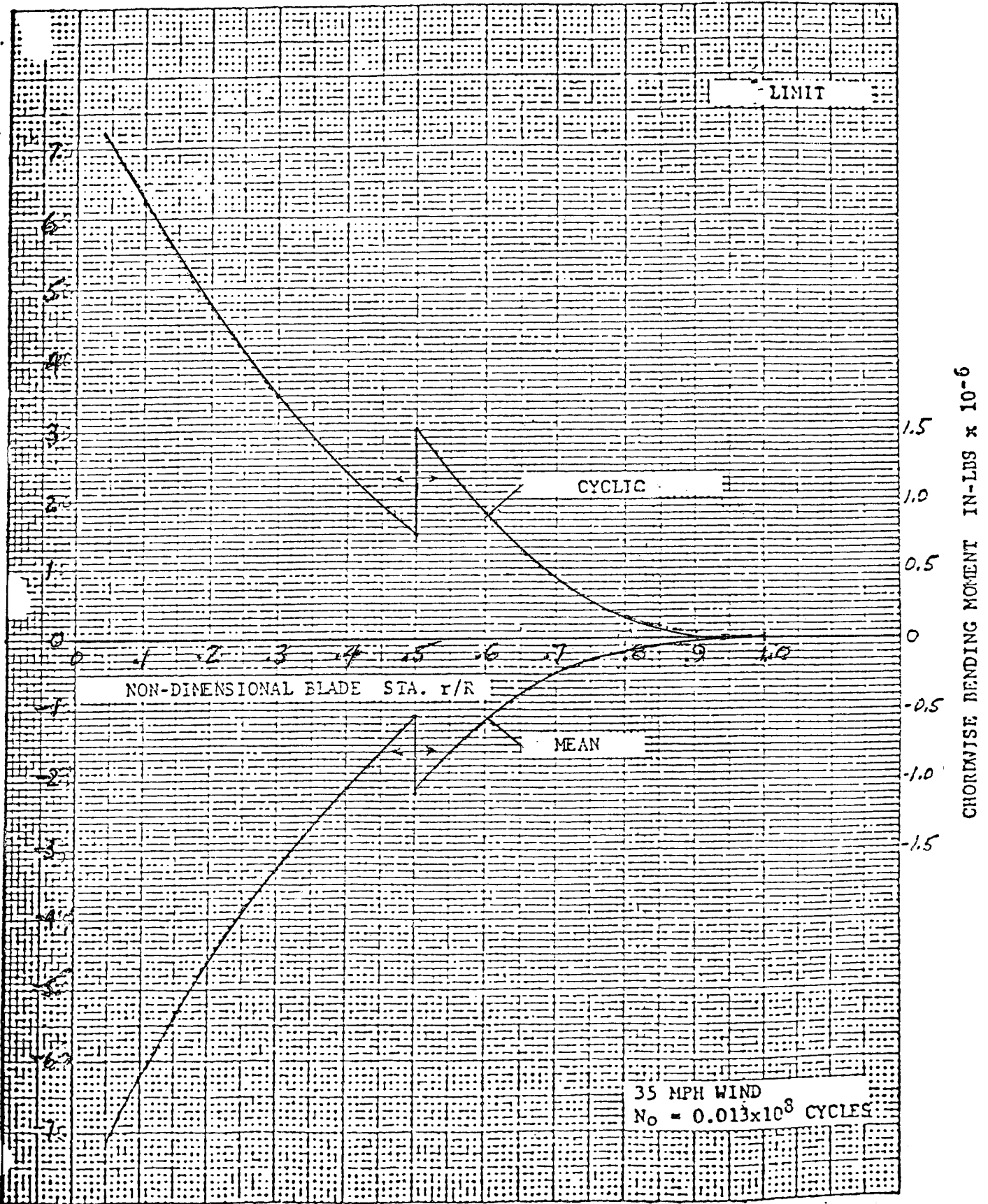

FIGURE -6

CHORDWISE BENDING MOMENT DISTRIBUTION

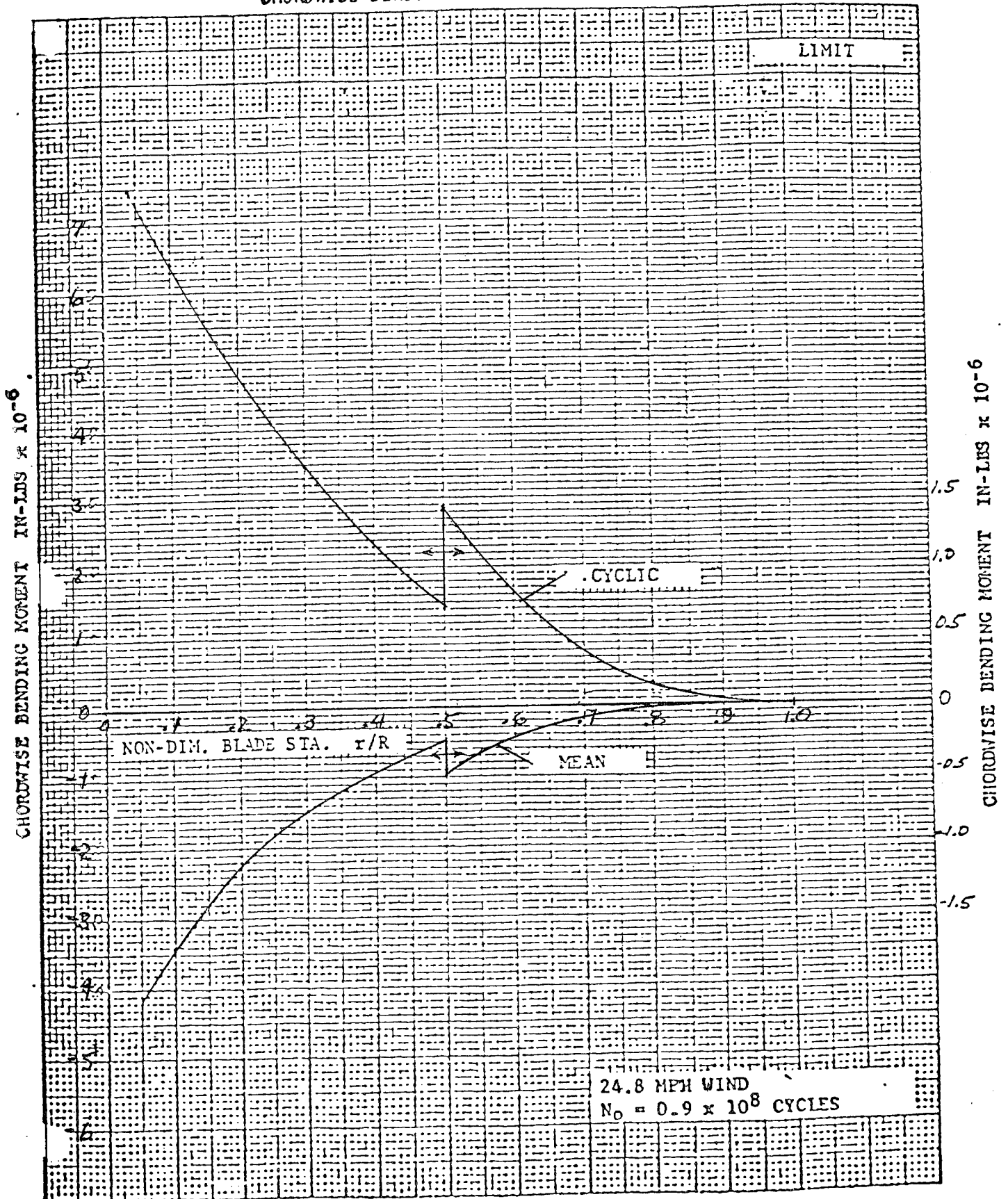
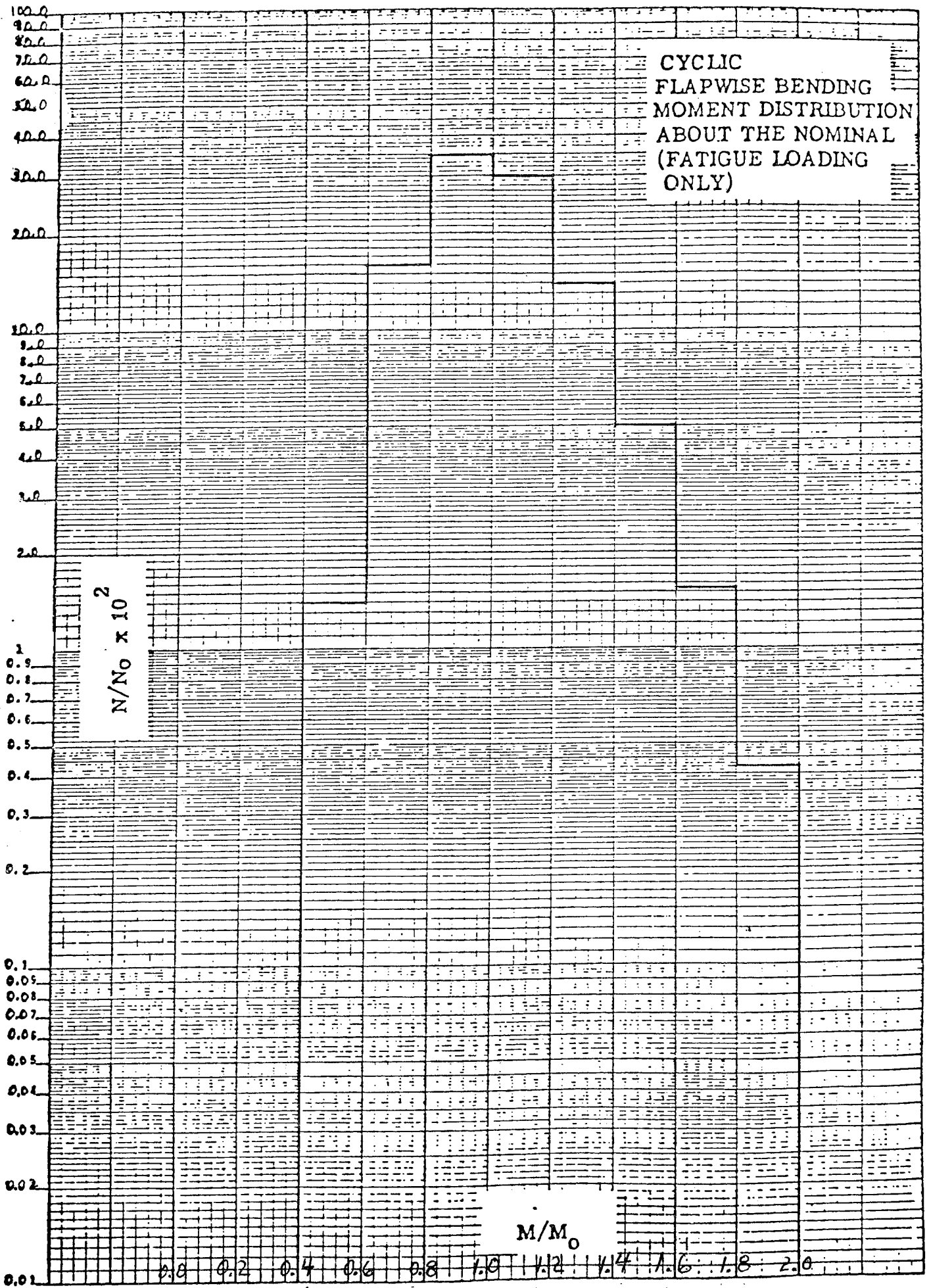
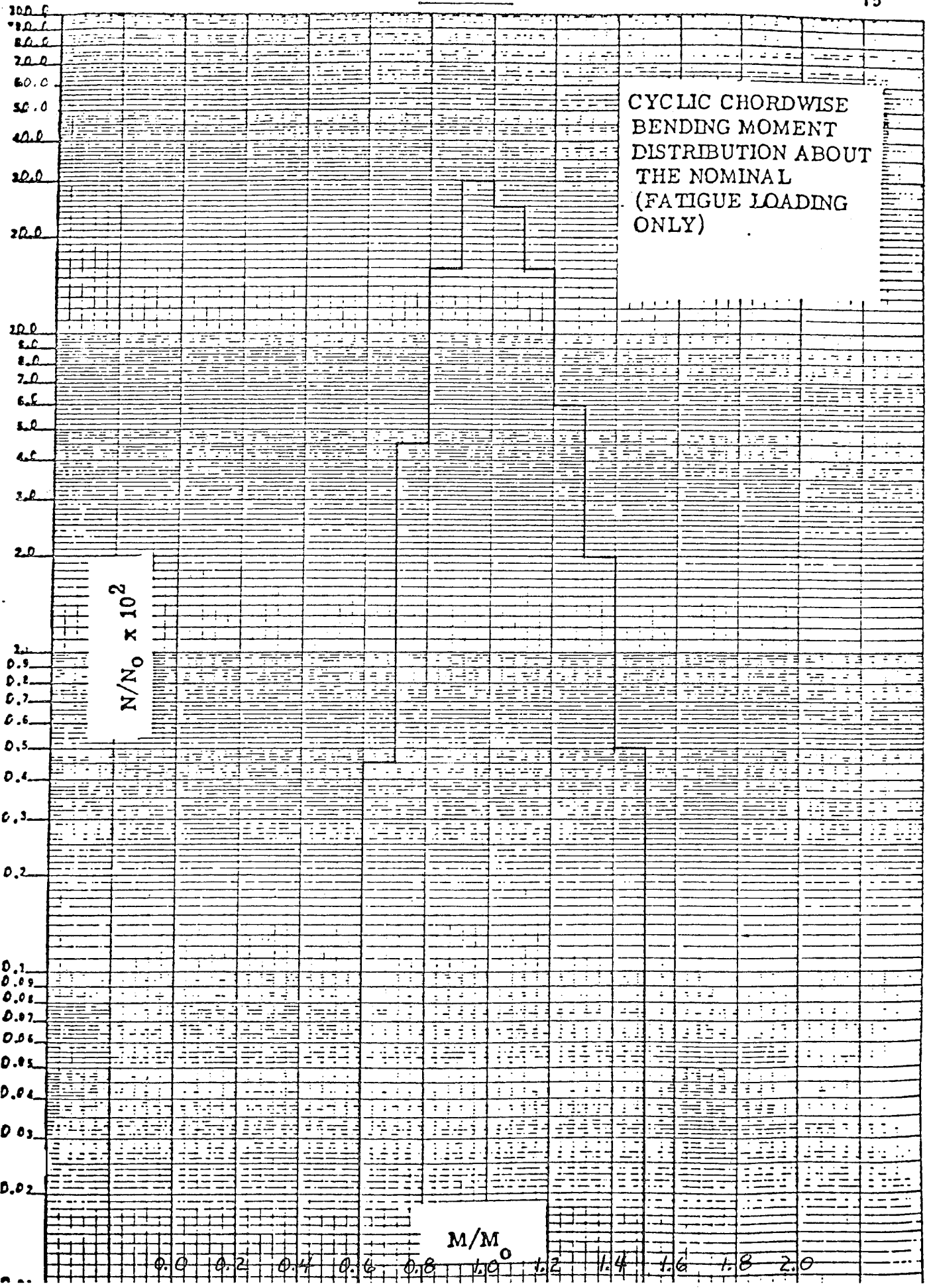

FIGURE -4a

CYCLIC
FLAPWISE BENDING
MOMENT DISTRIBUTION
ABOUT THE NOMINAL
(FATIGUE LOADING
ONLY)





CYCLIC CHORDWISE
BENDING MOMENT
DISTRIBUTION ABOUT
THE NOMINAL
(FATIGUE LOADING
ONLY)

$N/N_0 \times 10^2$

M/M_0

0.0 0.2 0.4 0.6 0.8 1.0 1.2 1.4 1.6 1.8 2.0

FLAPWISE BENDING MOMENT DISTRIBUTION

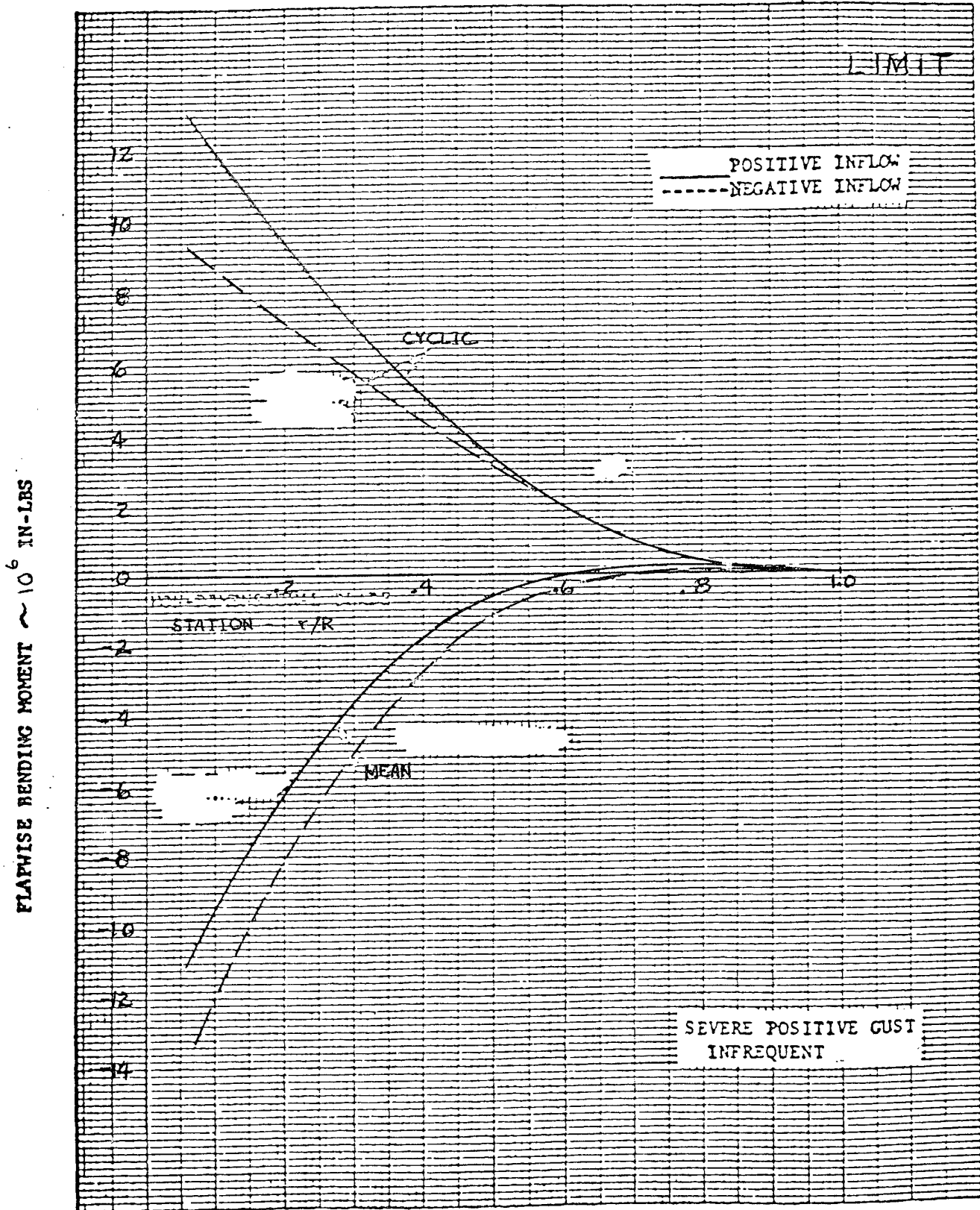

FIGURE -7

FLAPWISE BENDING MOMENT DISTRIBUTION

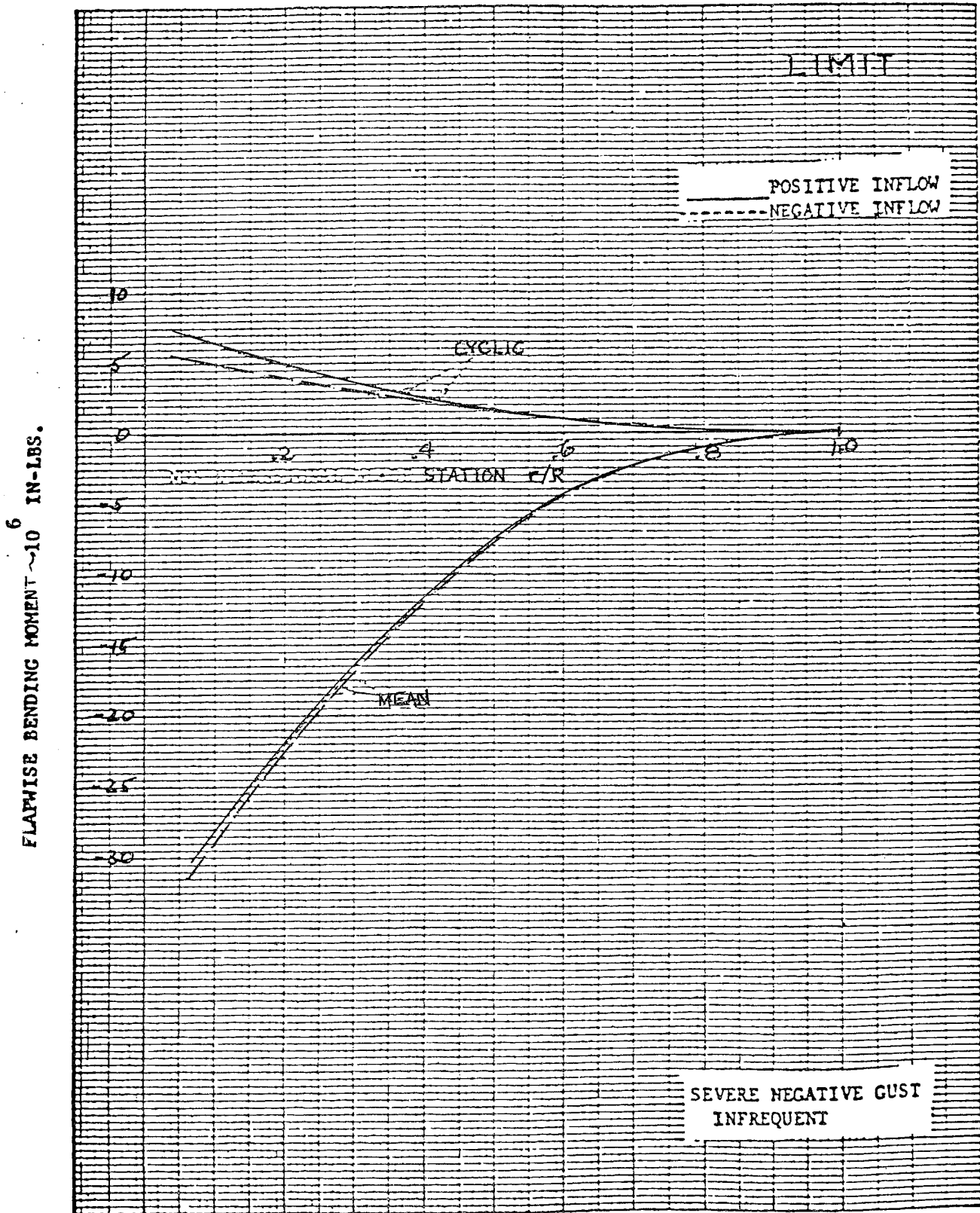

Figure -8

CHORDWISE BENDING MOMENT DISTRIBUTION

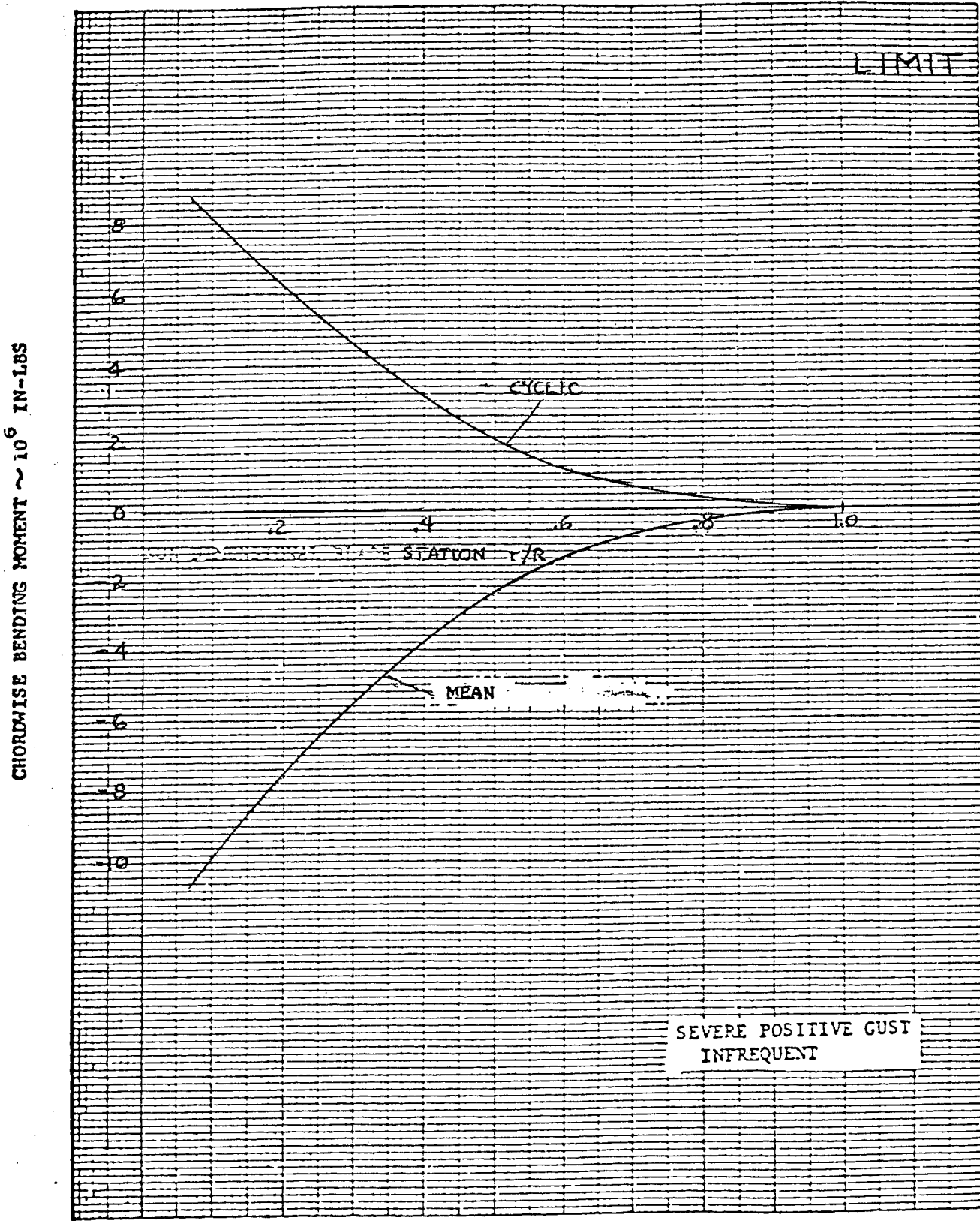

Figure -9

CHORDWISE BENDING MOMENT DISTRIBUTION

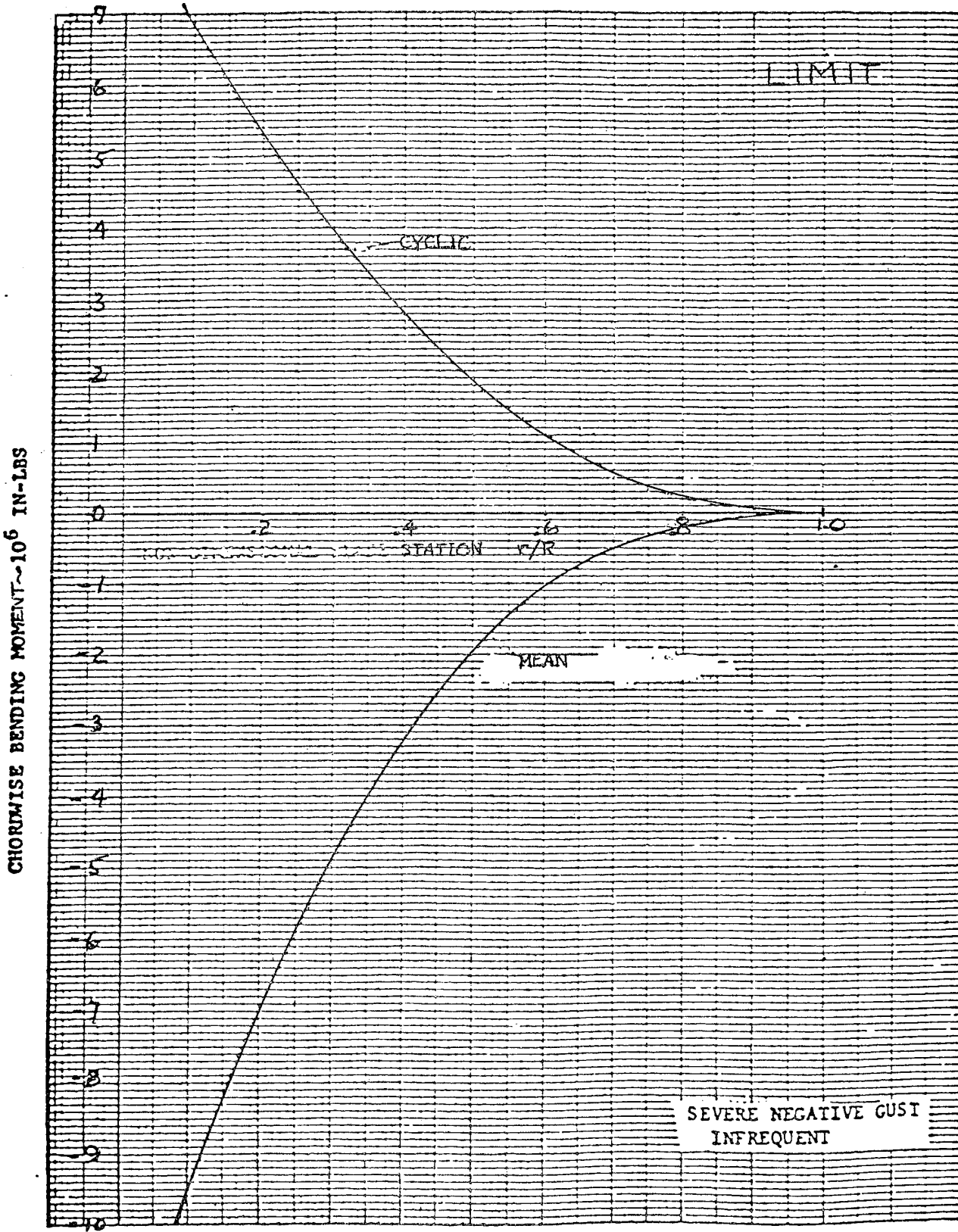

FIGURE -10

FLAPWISE BENDING MOMENT DISTRIBUTION

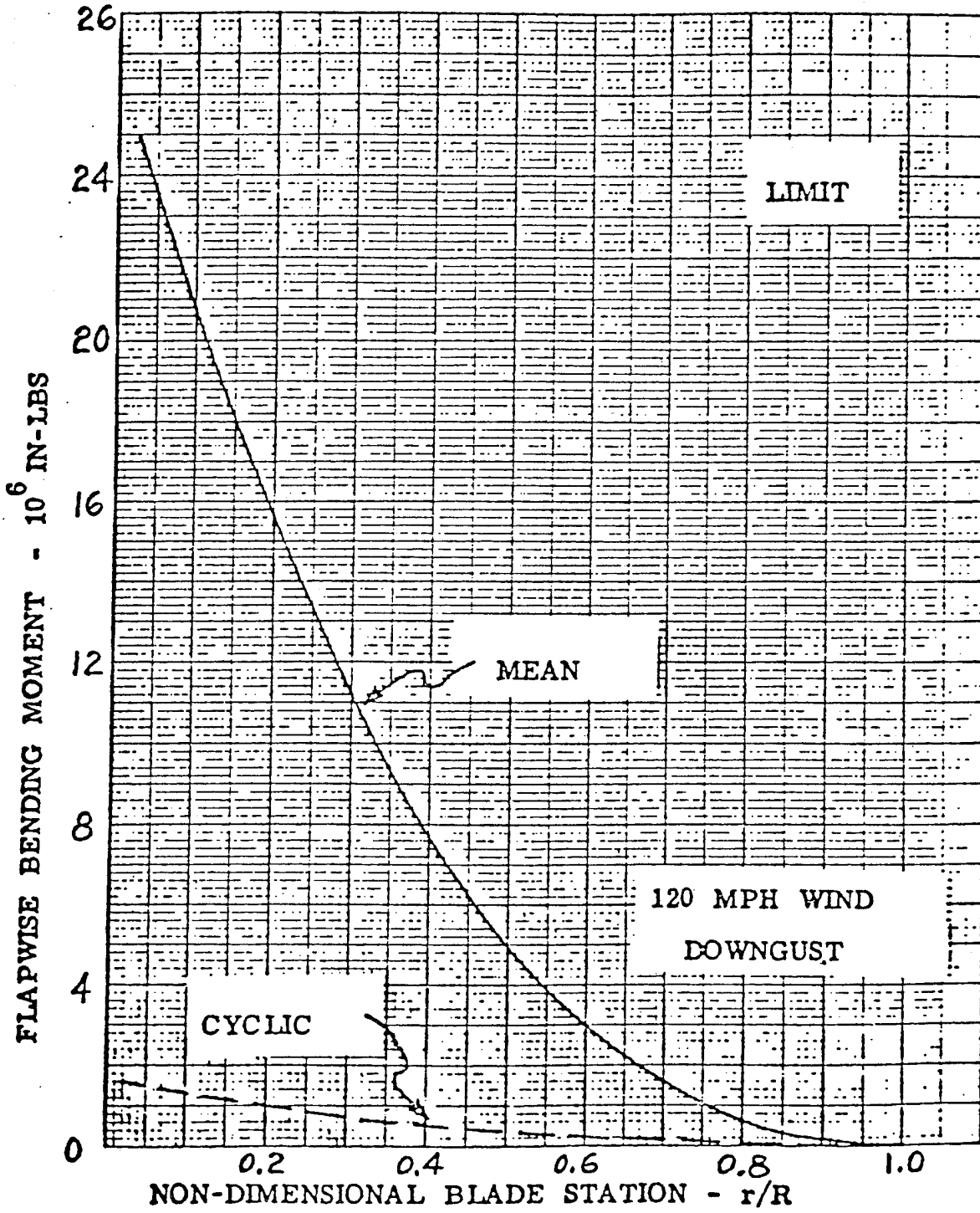

FIGURE - 11

CHORDWISE BENDING MOMENT DISTRIBUTION

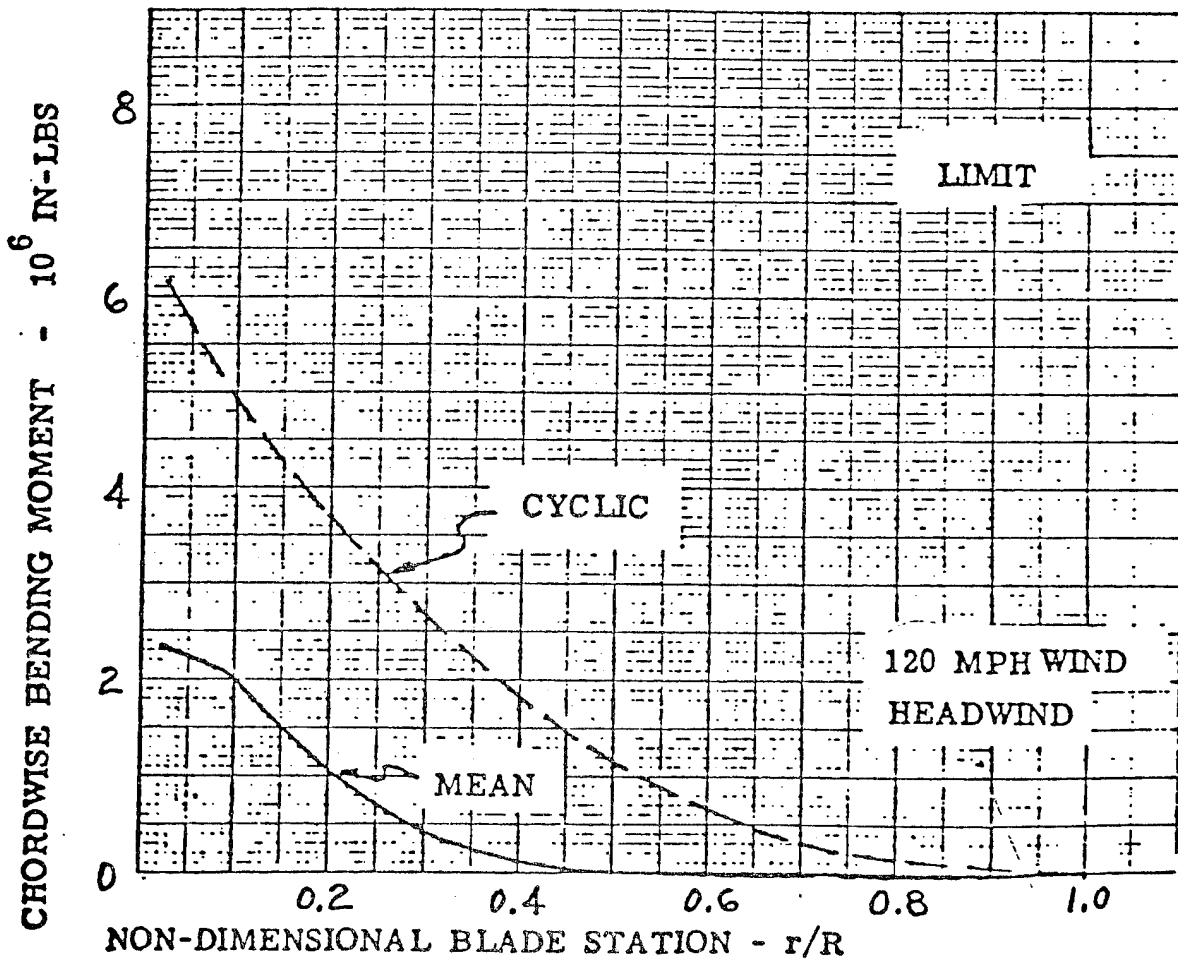

FIGURE - 12

273A6684
FLAPWISE BENDING MOMENT DISTRIBUTION

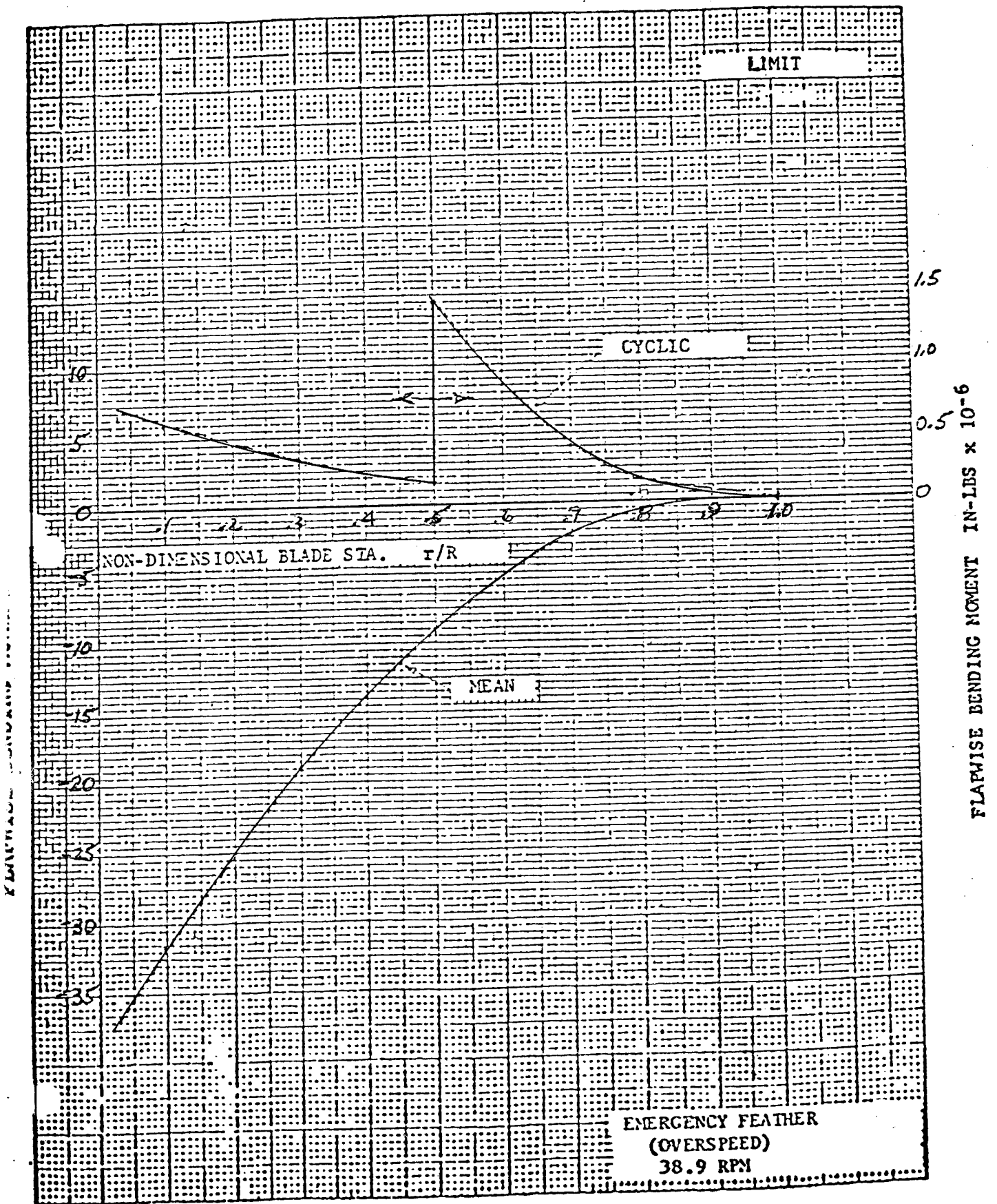

FIG. -13

273A6684

CHORDWISE BENDING MOMENT DISTRIBUTION

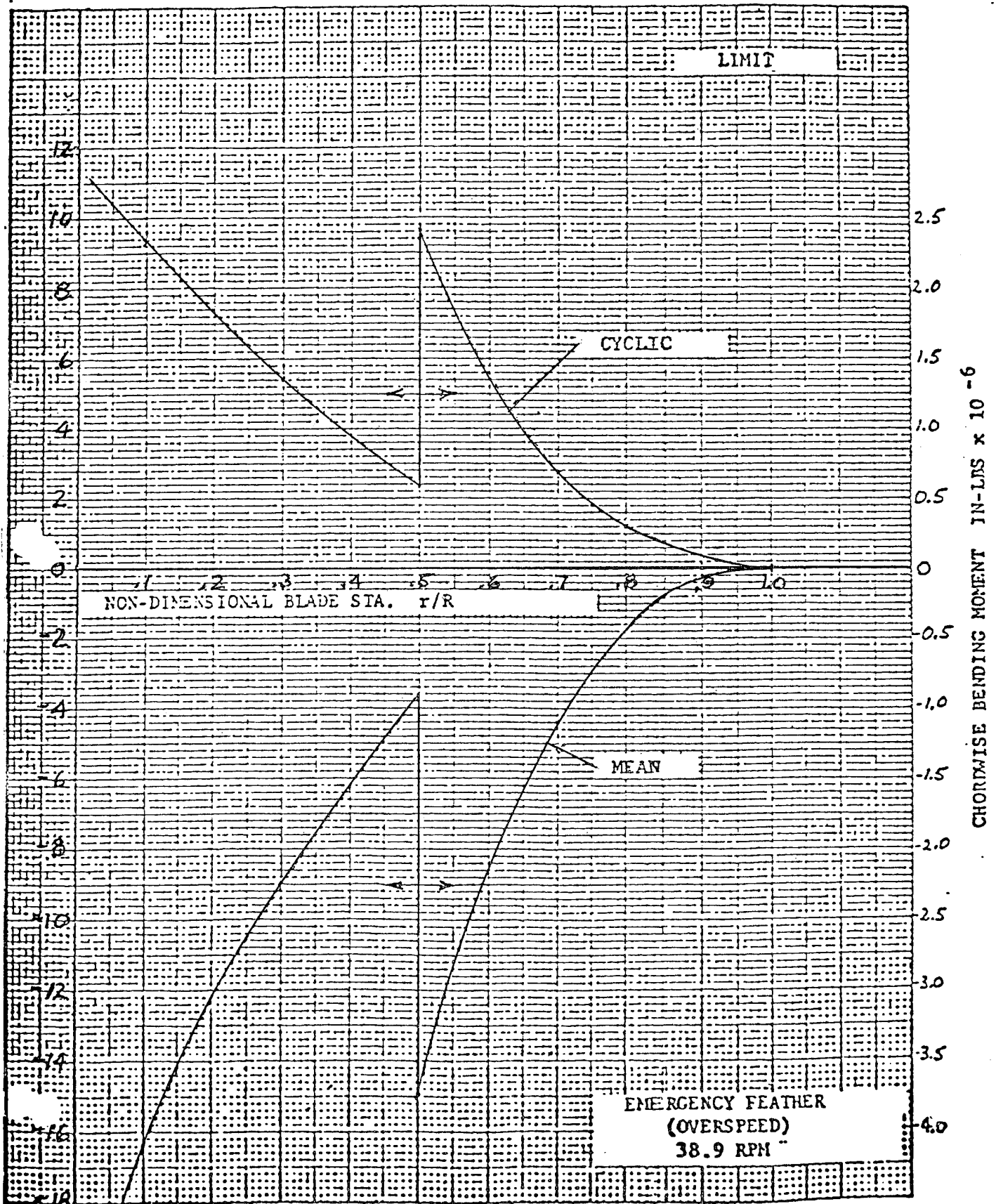

FIG. -14

SIGN CONVENTION FOR FLAPWISE
AND CHORDWISE MOMENTS

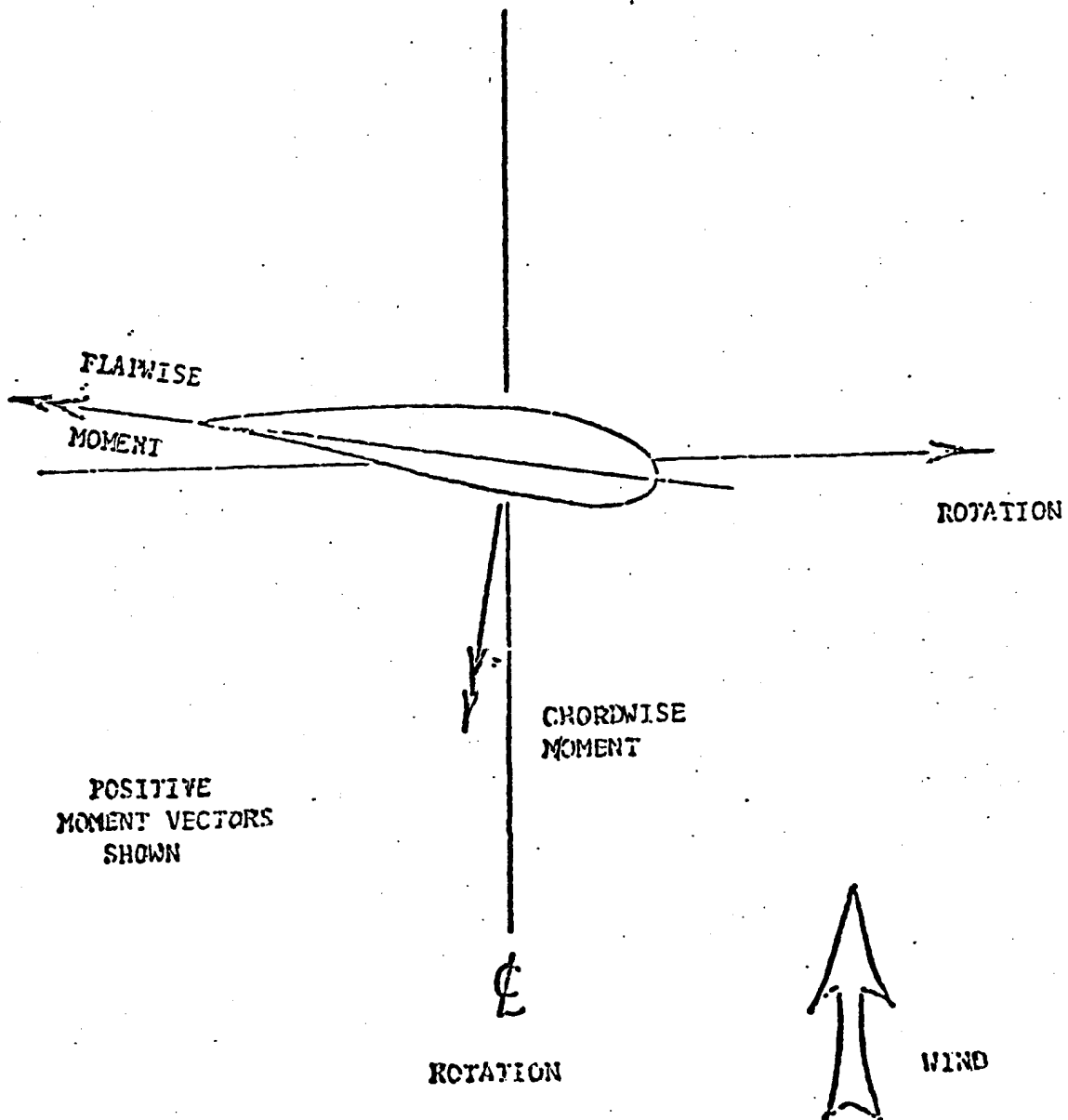

FIGURE -15

National Aeronautics and
Space Administration



Lewis Research Center
Cleveland, Ohio
44135

Reply to Attn of: 4510

July 21, 1980

Mr. William Batesole
Kaman Aerospace Corporation
Old Windsor Road
Bloomfield, CT 06002

Dear Bill:

This letter is to officially notify you that the Kaman recommendation to eliminate the plies of bias filament tape from the high-pressure surface of the blade is approved. Your revised buckling analysis combined with the results of the buckling tests on the demo spar have convinced us that the bias filament tape is not required. We understand that the 2.25 margin of safety on buckling cannot be maintained when the latest 38 rpm emergency shutdown loads are applied. However, it is our intent to operate the fiberglass blades on Mod-1 at only 23 rpm (27 rpm emergency shutdown). Therefore, any future margin-of-safety calculations for the emergency shutdown case should be based on the 27 rpm loads information which is enclosed.

I would also like to notify you that NASA LeRC is currently considering operating the Mod-1 wind turbine with the blades upwind of the tower. From our preliminary evaluation, it appears feasible, and, in fact, advantageous from the standpoint of cyclic blade loads. Additional effort will be required to assure ourselves that the higher steady and lower cyclic loads which are attributable to upwind operations do not cause either buckling or fatigue problems. A preliminary calculation of the flatwise operating load regime for the 35 rpm and 27 rpm document and the 23 rpm upwind configurations is enclosed. No Kaman action is required at this time. However, if we decide to operate the composite blades in the upwind configuration, you may be requested to review our loads analysis and/or spot check our evaluation of the resulting blade stresses.

Sincerely,

for 
James R. Faddoul

Enclosure

MOD-1 BLADE LIMIT LOADS DURING RAPID STOP
 FLATWISE, INBOARD

FLATWISE
 BENDING
 LOAD
 LIMIT,
 LB-IN

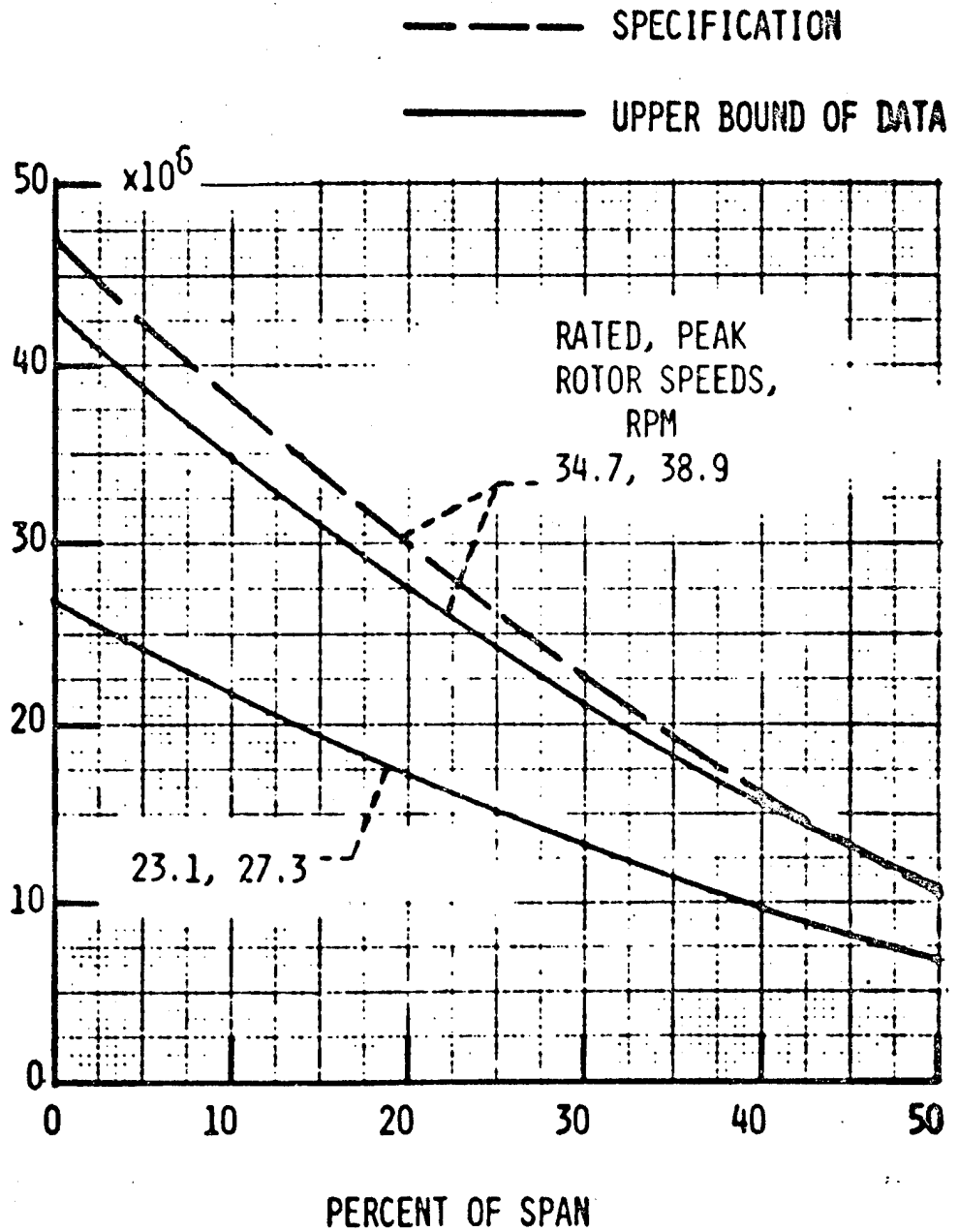

MOD-1 BLADE LIMIT LOADS DURING RAPID STOP
 FLATWISE, OUTBOARD

FLATWISE
 BENDING
 LOAD
 LIMIT,
 LB-IN

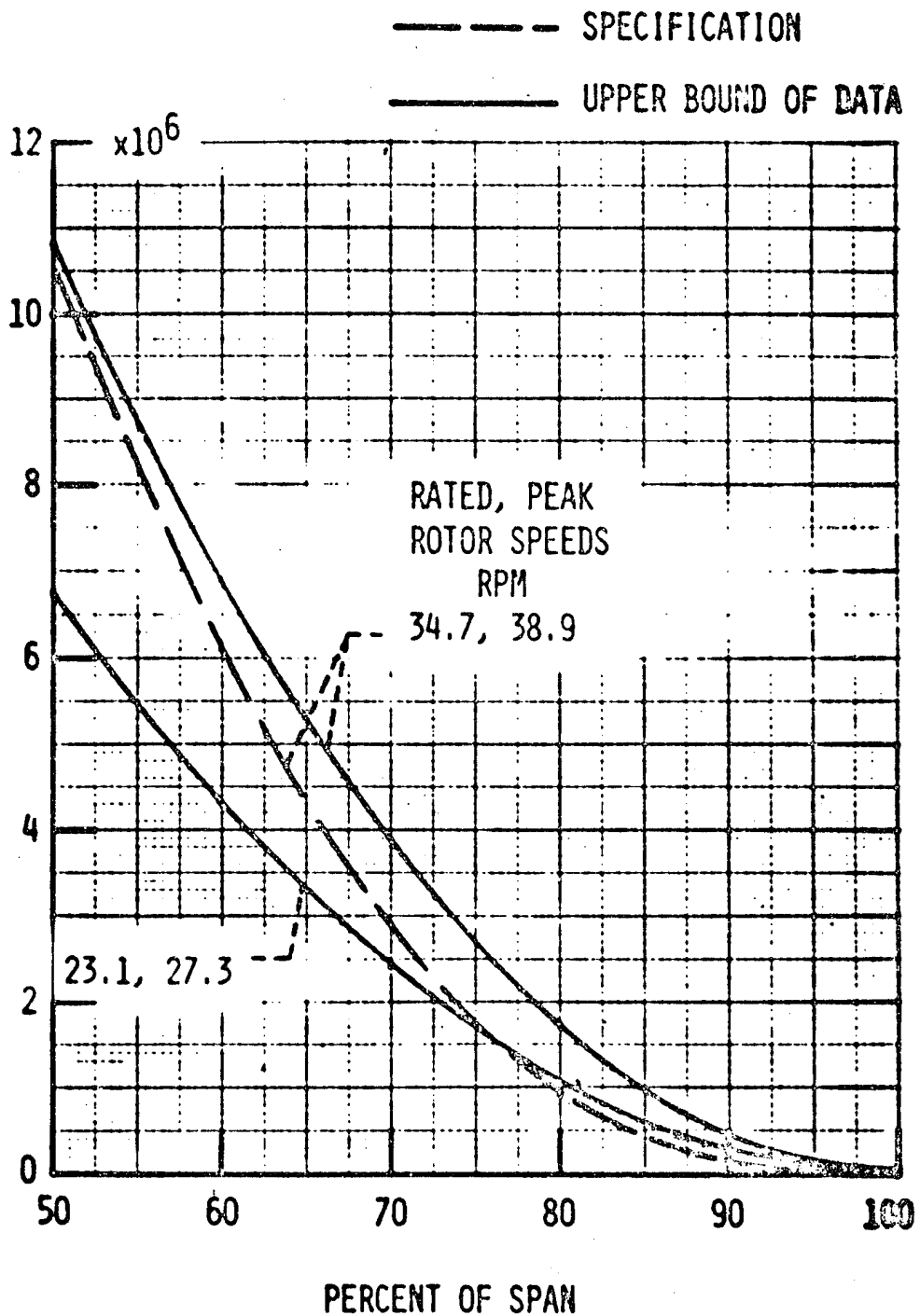

11-19-79

1. Report No. NASA CR-167987		2. Government Accession No.		3. Recipient's Catalog No.	
4. Title and Subtitle Design and Fabrication of Composite Blades for the Mod-1 Wind Turbine Generator				5. Report Date November 1981	
				6. Performing Organization Code 84955	
7. Author(s) William R. Batesole Clifford T. Gunsallus				8. Performing Organization Report No. R-1685	
				10. Work Unit No.	
9. Performing Organization Name and Address Kaman Aerospace Corporation Old Windsor Road, P.O. Box 2 Bloomfield, Connecticut 06002-0002				11. Contract or Grant No. DEN 3-131	
				13. Type of Report and Period Covered Contractor Report	
12. Sponsoring Agency Name and Address U. S. Department of Energy Distributed Solar Technologies Division Washington, D. C. 20545				14. Sponsoring Agency Code Report No. DOE/NASA/O131-1	
15. Supplementary Notes Final Report. Prepared under Interagency Agreement DE-AI01-76-ET2030 Project Manager, James R. Faddoul, Wind Energy Project Office, NASA Lewis Res. Ctr., Cleveland, Ohio 44135					
16. Abstract <p>In mid-1979, NASA contracted with Kaman Aerospace Corporation for the design, manufacture, and ground testing of two 100 foot composite rotor blades intended for operation on the MOD-1 wind turbine. NASA stipulated that the blades utilize, to the maximum extent practicable, the technology developed in a forerunner program in which Kaman produced a 150 foot test blade.</p> <p>The MOD-1 blades have been completed and are currently stored at the Kaman Facility.</p> <p>This paper describes the design, tooling, fabrication, quality control, and testing phases which have been carried out to date, as well as testing still planned. Discussed are differences from the 150 foot blade which were introduced for cost and manufacturing improvement purposes. Also included is a description of the lightning protection system installed in the blades, and its development program.</p> <p>Actual costs and manhours expended for Blade No. 2 are provided as a base, along with a projection of costs for the blade in production.</p>					
17. Key Words (Suggested by Author(s)) Fiberglass composites Wind turbine blades Rotor blades			18. Distribution Statement Unclassified - unlimited STAR Category 44 DOE Category UC-60		
19. Security Classif. (of this report) Unclassified		20. Security Classif. (of this page) Unclassified		21. No. of Pages	22. Price*