



US Army Corps
of Engineers

Construction Engineering
Research Laboratories

USACERL IR 96/31
January 1996

Abatement of Hazardous Air Pollutant Emissions From Army Chromium Electroplating and Anodizing Operations

by
K. James Hay

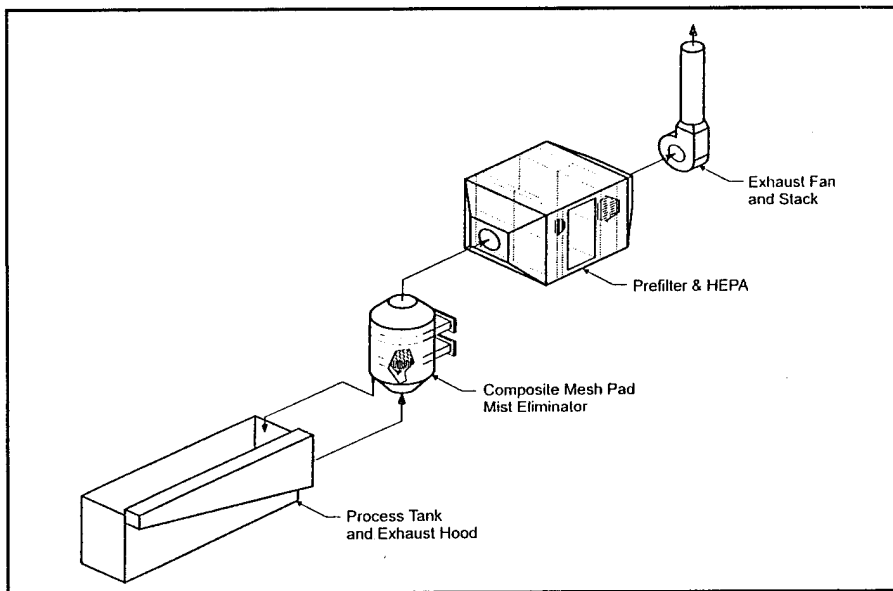

19960306 001

The U.S. Environmental Protection Agency regulates chromium air emissions generated from chromium electroplating and anodizing operations. The compliance deadline for hard chromium electroplating and anodizing is 25 January 1997. Currently eight Army installations have either hard chromium electroplating and/or anodizing operations, which must meet applicable regulations.

The overall objective this project is to develop control technologies to control hazardous air emissions from Army chromium electroplating and anodizing operations. This initial part of the study: (1) investigated the current status of Army compliance, (2) summarized available technologies and practices to control chromium emissions, and (3) made recommendations regarding technologies to help Army installations achieve compliance.

Approved for public release; distribution is unlimited.

Five basic options are available to chromium electroplaters and anodizing facilities to meet compliance limits:

1. Install new air pollution control equipment
2. Renew or adjust existing control devices
3. Use emission reduction practices at tank
4. Replace the current production process
5. Discontinue operation.

This study continues with pilot testing of a new technology, the Venturi/Vortex Closed Loop Scrubber, which may offer the potential for superior fume collection (while recycling emissions) at a significantly lower cost than current end-of-pipe control technologies.

The contents of this report are not to be used for advertising, publication, or promotional purposes. Citation of trade names does not constitute an official endorsement or approval of the use of such commercial products. The findings of this report are not to be construed as an official Department of the Army position, unless so designated by other authorized documents.

DESTROY THIS REPORT WHEN IT IS NO LONGER NEEDED

DO NOT RETURN IT TO THE ORIGINATOR

REPORT DOCUMENTATION PAGE

Form Approved
OMB No. 0704-0188

Public reporting burden for this collection of information is estimated to average 1 hour per response, including the time for reviewing instructions, searching existing data sources, gathering and maintaining the data needed, and completing and reviewing the collection of information. Send comments regarding this burden estimate or any other aspect of this collection of information, including suggestions for reducing this burden, to Washington Headquarters Services, Directorate for Information Operations and Reports, 1215 Jefferson Davis Highway, Suite 1204, Arlington, VA 22202-4302, and to the Office of Management and Budget, Paperwork Reduction Project (0704-0188), Washington, DC 20503.

1. AGENCY USE ONLY (Leave Blank)		2. REPORT DATE January 1996	3. REPORT TYPE AND DATES COVERED Final	
4. TITLE AND SUBTITLE Abatement of Hazardous Air Pollutant Emissions From Army Chromium Electroplating and Anodizing Operations			5. FUNDING NUMBERS 4A162720 D048 U05	
6. AUTHOR(S) K. James Hay				
7. PERFORMING ORGANIZATION NAME(S) AND ADDRESS(ES) U.S. Army Construction Engineering Research Laboratories (USACERL) P.O. Box 9005 Champaign, IL 61826-9005			8. PERFORMING ORGANIZATION REPORT NUMBER IR 96/31	
9. SPONSORING / MONITORING AGENCY NAME(S) AND ADDRESS(ES) Headquarters, U.S. Army Corps of Engineers ATTN: SFIM-AEC-EPD 20 Massachusetts Avenue, NW. Washington, DC 20314-1000			10. SPONSORING / MONITORING AGENCY REPORT NUMBER	
11. SUPPLEMENTARY NOTES Copies are available from the National Technical Information Service, 5285 Port Royal Road, Springfield, VA 22161.				
12a. DISTRIBUTION / AVAILABILITY STATEMENT Approved for public release; distribution is unlimited.			12b. DISTRIBUTION CODE	
13. ABSTRACT (Maximum 200 words) The U.S. Environmental Protection Agency regulates chromium air emissions generated from chromium electroplating and anodizing operations. The compliance deadline for hard chromium electroplating and anodizing is 25 January 1997. Currently eight Army installations have either hard chromium electroplating and/or anodizing operations, which must meet applicable regulations. The overall objective this project is to develop control technologies to control hazardous air emissions from Army chromium electroplating and anodizing operations. This initial part of the study: (1) investigated the current status of Army compliance, (2) summarized available technologies and practices to control chromium emissions, and (3) made recommendations regarding technologies to help Army installations achieve compliance. Five basic options are available to chromium electroplaters and anodizing facilities to meet compliance limits: 1. Install new air pollution control equipment 2. Renew or adjust existing control devices 3. Use emission reduction practices at tank 4. Replace the current production process 5. Discontinue operation. This study continues with pilot testing of a new technology, the Venturi/Vortex Closed Loop Scrubber, which may offer the potential for superior fume collection (while recycling emissions) at a significantly lower cost than current end-of-pipe control technologies.				
14. SUBJECT TERMS hazardous air pollutants air quality chromium			environmental compliance Army facilities	
15. NUMBER OF PAGES 46			16. PRICE CODE	
17. SECURITY CLASSIFICATION OF REPORT Unclassified	18. SECURITY CLASSIFICATION OF THIS PAGE Unclassified	19. SECURITY CLASSIFICATION OF ABSTRACT Unclassified	20. LIMITATION OF ABSTRACT SAR	

Foreword

This study was conducted for Headquarters, U.S. Army Corps of Engineers under Project 4A162720D048, "Industrial Operations Pollution Control Technology"; Work Unit U05, "Abatement of Hazardous Air Pollutant Emissions From Plating Operations." The assigned technical monitor was Louis Kanaras, SFIM-AEC-EPD.

The work was performed by the Industrial Operations Division (UL-I) of the Utilities and Industrial Operations Laboratory (UL), U.S. Army Construction Engineering Research Laboratories (USACERL). Acknowledgment is owed to Dr. David Reed and Linda Jekel, of the U.S. Army Center for Health Promotion and Preventive Medicine (MCHB-DE-AP) and to Mr. Peter Von Szilassy, of Versar, Inc., for their contributions to this study. The USACERL principal investigator was K. James Hay. Ralph E. Moshage is Acting Chief, CECER-UL-I; John T. Bandy is Operations Chief, CECER-UL; and Gary W. Schanche is Chief, CECER-UL. The USACERL technical editor was William J. Wolfe, Technical Resources Center.

Cover illustration reprinted with permission of Conserve Engineering Co., Laguna Beach, CA 92651, tel. 714/494-6440.

COL James T. Scott is Commander and Acting Director, and Dr. Michael J. O'Connor is Technical Director of USACERL.

Contents

SF 298	1
Foreword	2
List of Tables and Figures	5
1 Introduction	7
Background	7
Objectives	7
Approach	8
Scope	8
Mode of Technology Transfer	8
2 Technical Background	9
Description of Chromium Electroplating and Anodizing	9
Creation of Emissions	10
3 Regulations	12
NESHAP	12
State Regulations	13
OSHA Requirements	15
4 Survey of Army Operations	16
5 End-of-Pipe Treatment	18
Available Control Devices	19
Cost Comparisons	23
6 Emission Reduction Techniques	27
Chemical Fume Suppressants	28
Plastic Balls	29
Operation Practices	30
Control Equipment Optimization	30
Tank Cover	31
7 Venturi/Vortex Closed-Loop Scrubber Technology	32
Description	32
Plans for Testing and Technology Transfer	34

8	Compliance Recommendations	35
	General	35
	Hard Chromium Electroplating Facilities	36
	Chromium Anodizing Facilities	37
9	Summary and Recommendations	38
	Summary	38
	Recommendations	39
	References	40
	Abbreviations	42
	Distribution	

List of Tables and Figures

Tables

1	Hard chromium electroplating and anodizing NESHAP limits	12
2	Hard chromium electroplating and anodizing operations in the U.S. Army	17
3	End of pipe control device output concentrations and cost comparisons	25
4	Estimated capital costs for end-of-pipe control devices at a new facility	25
5	Estimated annualized costs for end of pipe control devices	26

Figures

1	Packed bed scrubber	20
2	Horizontal four-stage composite meshpad unit	21
3	Cross-sectional view of a single cylinder fiber bed mist eliminator	22
4	T-BACT system	24
5	Venturi/vortex closed-loop scrubber	33

1 Introduction

Background

Under the Clean Air Act Amendments of 1990, the U.S. Environmental Protection Agency (USEPA) has designated chromium compounds as hazardous air pollutants suspected of causing lung cancer in humans. The USEPA has promulgated a National Emission Standard for Hazardous Air Pollutants (NESHAP) that regulates the chromium air emissions generated from chromium electroplating and anodizing operations (60 FR 4948). The final rule, published 25 January 1995, set a compliance deadline of 25 January 1996 for decorative chromium electroplating and 25 January 1997 for hard chromium electroplating and anodizing. Under this rule, a chromium plating or anodizing facility may select the means to reduce emissions as long as compliance is demonstrated. In addition to the NESHAP, individual states may have different (or additional) regulations. Moreover, state regulations are usually more stringent than the national standard and may be based on ground level concentrations (GLC), or risk-based assessments.

Currently eight Army installations have either hard chromium electroplating and/or anodizing operations. These facilities treat many parts for corrosion and wear performance such as helicopter gears, cannon barrels, vehicle components, and tools. Installations that have plating facilities may need assistance in making the best compliance technology decisions. U.S. Army installations with chromium electroplating or anodizing facilities must be prepared to meet both state and federal regulations.

Objectives

The overall objective of this project is to develop control technologies that effectively and economically control hazardous air emissions from Army chromium electroplating and anodizing operations. The objectives of this initial part of the study were to:

1. Investigate the current status of Army compliance
2. Summarize current technologies and practices to control chromium emissions

3. Investigate and evaluate new control technologies being developed
4. Make recommendations regarding the use of currently available technologies to help Army installations achieve compliance.

Approach

Information pertaining to technologies and practices was gathered through a literature search, through consultation with other professionals in the field, and by experimentation. A telephone survey of Army chromium operations was conducted. The U.S. Army Center for Health Promotion and Preventive Medicine performed experimentation and some information gathering included in this report as well.

Scope

Although the majority of air pollution technologies specifically used for chromium emissions were reviewed for this study, this report focuses on only the most common and effective of those technologies. State and federal regulations reviewed and cited were current as of 1 July 95. The survey described in this report included 122 Army installations in the continental United States.

Mode of Technology Transfer

The results of this research will be used to develop control technologies that effectively and economically control hazardous air emissions from Army chromium electroplating and anodizing operations.

2 Technical Background

Description of Chromium Electroplating and Anodizing

Hard Chromium Electroplating

Chromium electroplating is a widely used process for depositing chromium metal onto a substrate, typically steel for hard chromium electroplating. Chromium offers combined properties not found in any other metal: hardness, high reflectance, high corrosion resistance, low coefficient of friction, high heat conductivity, and excellent wear resistance. Because of these combined properties, chromium electroplating has played an important role in coating military hardware and is essential to the mission and readiness of the U.S. Army.

In the chromium electroplating process, a direct current is applied between the anode(s) and cathode(s) (the part) while suspended in a hexavalent chromium-plating solution (chromium in the +6 valence state). The bath temperature is usually kept between 50 and 65 °C. The bath contains 225 to 375 g/L (usually 240 g/L) of chromic anhydride (CrO_3), which creates an aqueous solution of chromic acid (H_2CrO_4). Sulfuric acid (H_2SO_4) is also present at 2.25 to 3.75 g/L to act as a bath catalyst. At these high concentrations, the chromic acid forms dichromic acid ($\text{H}_2\text{Cr}_2\text{O}_7$), which then ionizes to dichromate ($\text{Cr}_2\text{O}_7^{-2}$) and hydrogen (H^+) ions.

Three chemical reactions take place at the cathode: (1) the deposition of chromium on the part surface, (2) the evolution of hydrogen gas (H_2), and (3) the reduction of hexavalent chromium to trivalent chromium (+3 valence state). Three reactions also take place at the anode, which is usually made of lead alloyed with tin or antimony: (1) the oxidation of the anode, (2) the evolution of oxygen gas (O_2), and (3) the oxidation of trivalent chromium to hexavalent chromium. The surface area of the anode is necessarily larger than the surface area of the part to be plated to ensure that this last reaction takes place. This helps minimize the contamination of the bath by trivalent chromium.

Chromium electroplating is a very inefficient process in that over 80 percent of the applied energy goes into the evolution of the byproduct gases, hydrogen and oxygen. This inefficiency contributes to the creation of emissions (USEPA, July 1993a).

Decorative Chromium Electroplating

The decorative hexavalent chromium electroplating process is very similar to hard chromium electroplating except in: (1) the current applied, (2) the duration of plating, and (3) the substrate plated. A thin layer of chromium is applied to the base material to provide a bright wear and tarnish resistant surface. Because decorative parts are generally plated at lower currents and for less time than hard chromium electroplated parts, emission generation per surface area plated is usually also less. The U.S. Army does not operate any strictly decorative chromium electroplating facilities.

Chromium Anodizing

Chromium anodizing is the process of electrolytically oxidizing the surface of a substrate, typically aluminum. An oxidized layer on the surface of a part provides corrosion resistance, low conductivity, and an accepting surface for coloring. Although there are different types of anodizing processes, chromium anodizing is preferred because chromic acid acts as a corrosion inhibitor and remains in the pores and crevices of a part after the process is complete (USEPA, July 1993a). These advantages make chromium anodizing especially suitable for anodizing military aircraft parts.

The equipment used for both the chromium anodizing and chromium electroplating processes is similar. However, in anodizing, the part is the anode and the tank is the cathode. Also, in the anodizing operation, the voltage is varied and the chromic acid concentration and bath temperature are lower than in electroplating.

Creation of Emissions

Oxygen and hydrogen gases generated at the cathode and anode during the electroplating or anodizing process rise to the plating bath surface as bubbles; the gases then escape as the bubbles burst. Each bursting bubble ejects a small drop of plating solution into the air above. The cumulative effect is the generation of a fine mist above the plating tank. The amount of gases generated is a function of the electrochemical activity in the tank, controlled by the bath composition, bath temperature, current applied, and the surface area of the part(s). Emissions will be a direct function of the generation of gases, but can be affected by the surface tension of the plating solution, shape of the part(s), depth and arrangement of the part(s) and anode(s), and any physical barrier located at the solution/air interface. The USEPA (July 1993a) found an average emission generation for hard chromium electroplating operations of 10 mg/Amp-hr with a range of values from 3.2 to 22.5 mg/Amp-hr.

In an anodizing operation, emissions are generated in the same manner as for hard chromium electroplating with the exception that emissions will decrease with anodizing duration. As an oxide layer grows on the part, the resistance to current increases, thereby decreasing the generation of gases and emissions.

According to Miles, Miles, and Michel (1995), an unpublished source has indicated that particulate emissions from a hard chromium electroplating facility ranged 0.3 to 25 mm in diameter with the mean diameter near 8 mm (Powers 1985). These small aerosol particles of plating solution can become even smaller through evaporation as they are exposed to ambient air.

3 Regulations

NESHAP

The Clean Air Act Amendments (CAAA) of 1990 (42 USC 7412), required the USEPA to establish National Emission Standards for all major sources and some area sources for 189 hazardous air pollutants (HAP). Due to the documented carcinogenic nature of hexavalent chromium (50 FR 24317), the USEPA targeted the electroplating industry as a major source of hexavalent chromium air pollution (57 FR 31576) and proceeded to create regulations pertaining to this industry. The NESHAP for chromium electroplating and anodizing, first proposed on 16 December 1993 (58 FR 65768), was published in the Federal Register on 25 January 1995 (60 FR 4948). This NESHAP imposes chromium emission concentration limits and/or plating bath surface tension limits for chromium electroplating and anodizing major and area sources, where a source has been defined as one electroplating or anodizing tank. Hard chromium electroplating and anodizing sources must be in compliance by 25 January 1997. This study addressed only emission concentration and surface tension requirements and ways to meet these limits. The NESHAP specifies additional compliance requirements such as work practice, monitoring, recordkeeping, and reporting. Newton (1995), USEPA (April 1995), and Altmayer (March 1995) summarize and list these requirements.

Table 1 summarizes the compliance limits based on Maximum Achievable Control Technology (MACT). Each MACT was selected because, according to the USEPA, it offers the maximum degree of reductions in hazardous emissions and can be achieved by taking into consideration the economics, the health and environmental impacts, and energy requirements of the regulated process. Note that the measured exhaust

Table 1. Hard chromium electroplating and anodizing NESHAP limits.

Tanks	Exhaust Concentration (mg Cr / dscm air)	MACT*	Surface Tension (dynes/cm)
All new tanks and existing large tanks	0.015	CMP	—
Existing small tanks	0.03	PBS	—
All anodizing tanks	0.01	FS	45
* CMP = Composite Meshpad PBS = Packed Bed Scrubber FS = Fume Suppressant dscm = dry standard cubic meter			

concentration of chromium can be either a hexavalent chromium concentration or a total chromium concentration; the choice is made by the facility.

The NESHAP is based on output concentration from the MACT control device as opposed to usage (mg/Amp-hr). This is based on the (weak) assumption derived from data compiled during the rulemaking process that the output concentration of modern control devices (or MACT) is independent of input concentration (USEPA, July 1993b). Anodizing facilities have a choice to meet either the concentration standard or the surface tension standard.

Currently, there is much talk in the plating industry about whether these compliance limits are too stringent and whether they can be feasibly met. A large concern exists for shops that purchased state-of-the-art control equipment within the past 5 years. These shops could be financially punished if their equipment fails to meet the limit despite the fact that they have already taken an early initiative to control their emissions. The USEPA would like to review any data that shows that MACT technology purchased and installed in the last 5 years cannot meet the standards. A convincing case could ultimately lead to a change in the limit. Also, there is a current proposal to eliminate Title V permitting for small, hard chromium electroplaters for 5 years.

Also, the USEPA has a current program under the Common Sense Initiative to find quick, economical ways to bring chromium electroplaters into compliance, and to see if the imposed compliance concentration limit is reasonable achieved. If they document that it cannot be reasonably achieved, it is possible that the regulation may be modified.

State Regulations

The USEPA has given the states the option to either adopt the federal regulation (60 FR 4948) or to create/modify state regulations that are at least as stringent. Every state that is relevant to the Army's chromium electroplating and anodizing operations will adopt or has adopted the federal regulation along with some type of ambient air level or risk-based standard addition as part of their permitting process. An ambient air level standard usually refers to a maximum allowable hexavalent chromium concentration at the fence line of the facility over a certain time-weighted average. Risk-based standards refer to a health risk to an individual, usually a maximum concentration beyond the fence line is considered. The USEPA, as required under the CAAA, will also consider risk-based standards as well as part of the next stage in

regulations scheduled to occur in about 7 years. Some states plan to wait until this happens before modifying their own regulations.

The states with Army chromium electroplating and/or anodizing operations and their considerations are presented in the following sections.* Note the variance in the fence line concentrations or risk concentration from state to state. Missouri has an extremely strict 24-hr averaged fence line concentration of $0.003 \mu\text{g}/\text{m}^3$. Illinois, by comparison, is quite high at $4.24 \mu\text{g}/\text{m}^3$ (a three-orders-of-magnitude differential).

Alabama

Alabama requires new or modified sources to meet a fence line concentration. the value is currently the Occupational Safety and Health Administration's (OSHA) threshold limit value (TLV), $0.05 \text{ mg}/\text{m}^3$, divided by 40 as a 1-hr average.

Connecticut

Connecticut allows a maximum allowable fence line average concentration of $0.25 \mu\text{g}/\text{m}^3$ over 8 hrs and $1.25 \mu\text{g}/\text{m}^3$ over 30 minutes for chromic acid. These values are also used to back-calculate maximum allowable stack concentrations using a simple model.

Illinois

Illinois has a screening process for new, modified and existing sources up for permit review. The annual maximum average fence line concentration is $8.33 \times 10^{-5} \mu\text{g}/\text{m}^3$ and the 24-hr average is $4.24 \mu\text{g}/\text{m}^3$.

Missouri

In Missouri, the Acceptable Ambient Levels (AALs) for hexavalent chromium at the fence line is $0.003 \mu\text{g}/\text{m}^3$ averaged over 24 hrs.

New Jersey

New Jersey has a risk-based screening process for new or modified sources. A source's risk of one in one million cancer risk is acceptable. A risk of one in ten thousand is

* Information on individual states provided by Linda Jekel, U.S. Army Center for Health Promotion and Preventive Medicine, facsimile transmission (3 August 1995).

deemed not acceptable and further pollution control is required. A risk in between these values is handled on a case-by-case basis.

New York

New York currently uses risk-based modeling in the permitting process. The law stipulates no concentration values, but general guidelines used by the permittees are $0.1 \mu\text{g}/\text{m}^3$ for short-term average concentration (less than 1 hr) and $2.0 \times 10^{-5} \mu\text{g}/\text{m}^3$ for an annual average concentration. There is much controversy as to whether this risk-based evaluation will be added on to the adopted federal regulation.

Pennsylvania

Regional review engineers in Pennsylvania use a risk-based screening process for new or modified sources. The maximum allowable concentration for hexavalent chromium beyond the fence line is $0.00833 \mu\text{g}/\text{m}^3$. This concentration is based on a one out of one million excess cancer risk. This risk-based screening is usually done only around the Philadelphia area; other regions in the state usually only look at the control device and its potential emissions.

Texas

Texas uses a risk-based screening process for new and modified sources. If a source exceeds the Effects Screening Level (ESL), then a more detailed risk-based evaluation is pursued to determine a more accurate perception of the risk. Existing sources normally will not go through this evaluation if they exhibit a good compliance record and if no complaints have been registered. The ESL for hexavalent chromium is $0.1 \mu\text{g}/\text{m}^3$ for a 30-minute average and $0.01 \mu\text{g}/\text{m}^3$ for an annual average.

OSHA Requirements

Platers are at the greatest health risk due to fugitive emissions from the source. Adequate ventilation is required to remove emissions before they escape into the working area. The current OSHA worker breather zone chromium concentration limit or TLV is set at $0.05 \text{ mg}/\text{m}^3$ (29 CFR 1910.94). This requirement is scheduled to change some time near the end of the 1995 calendar year to an expected value of $0.5 \mu\text{g}/\text{m}^3$ as an 8-hr time-weighted average.

4 Survey of Army Operations

A survey was performed to define the current U.S. Army chromium electroplating and anodizing usage and to document potential compliance problems with chromium emissions. Most of the large electroplating facilities are readily quantifiable, but the possibility of numerous small operations existing in the Army prompted the survey.

The survey involved 122 installations, or all the installations in the continental United States of the three major commands (MACOMs); the U.S. Army Forces Command (FORSCOM), the U.S. Army Training and Doctrine Command (TRADOC), and the U.S. Army Materiel Command (AMC); as well as the major tenants of Aberdeen Proving Ground, MD (von Szilassy 1995). The survey was conducted by telephone; questions pertained to the usage of chromium electroplating or anodizing operations, current control devices, plans to meet compliance, and any trials with new technologies.

The survey found only eight AMC installations with hard chromium electroplating and/or anodizing. Five of these installations perform electroplating only, two perform electroplating and anodizing, and one performs anodizing only. No installations perform strictly decorative electroplating. Neither FORSCOM nor TRADOC had electroplating or anodizing facilities. Table 2 lists these activities and indicates whether a hard chromium electroplating facility will be considered large or small under the NESHAP.

The compliance status of the eight installations with chromium electroplating or anodizing facilities is:

1. Rock Island Arsenal and Watervliet Arsenal have MACT and expect to be already in compliance.
2. Corpus Christi Army Depot and Red River Army Depot are both putting in new plating facilities incorporating MACT.
3. Anniston Army Depot and Lake City Army Ammunition Plant are currently seeking MACT to install.
4. Letterkenny Army Depot is scheduled for closure under Base Realignment and Closure (BRAC 95), but still intends to be in compliance by the deadline. Currently, Letterkenny has a packed bed scrubber.

Table 2. Hard chromium electroplating and anodizing operations in the U.S. Army.

Installation	Hard Chromium Electroplating Tanks	Chromium Anodizing Tanks	Primary Usage
Anniston Army Depot, AL	Five 1500 gal tanks, one 1300 gal tank (large)	None	Bearing surfaces, shafts for engines and transmissions
Corpus Christi Army Depot, TX	Five 450 gal tanks operated at 850 amps (large)	One 250 gal tank operated at 40 to 50 Amps	Helicopter gears/wear parts
Lake City Army Ammunition Plant, MO	One 350 gal tank with 500 Amp capacity (small)	None	Wear surfaces on tooling
Letterkenny Army Depot, PA	Two 850 gal tanks plus four larger tanks (large)	None	Wear surfaces on artillery and other equipment
Red River Army Depot, TX	One 1200 gal tank operated ten hours/week (small)	One 1200 gal tank operated 40 hr/wk	Vehicle components, cylinders, hinges
Rock Island Arsenal, IL	14 tanks each with capacities between 700 and 1000 Amps (large)	None	Cannon barrels, manifolds, and equipment
Stratford Army Engine Plant, CT	None	One tank operating at less than 20 Amps	Aircraft engine components
Watervliet Arsenal, NY	Five deep tanks and five 1500 gal tanks (large)	None	Cannon tube bores for anti-corrosion and wear

5. Stratford Army Engine Plant, the one installation performing only anodizing, has no control device. Due to the limited use of the facility, Stratford is attempting to submit a variance application to the MACT.

5 End-of-Pipe Treatment

In recent years, end-of-pipe control technologies have been the most accepted method for treating fugitive emissions from the hard chromium electroplating industry. The term "end-of-pipe" denotes the treatment of a contaminated airstream that has been drawn off a plating tank by a blower. The airstream flows into an end-of-pipe control device by way of ductwork, where the emissions are removed before being vented to the atmosphere. The design objective of these devices is to provide a barrier surface for the particulate emissions to adhere and coalesce as they pass through. Barrier surfaces can range from metal blades to a fibrous media, or even the wetted surface of a packed bed or fibrous media. In the case of a wet scrubber, water droplets act as barrier surfaces.

The particles can contact the barrier by one of three mechanisms: (1) direct impaction, (2) interception, or (3) diffusion. Direct impaction occurs when a particle possesses adequate momentum so that it cannot follow air streamlines around a barrier; instead the particle directly collides with the barrier. This is the predominate mechanism of larger drops ($d > 10 \mu\text{m}$, where d is the diameter of the particle). For smaller drops ($1 \mu\text{m} < d < 10 \mu\text{m}$), which tend to follow air streamlines more easily, interception may occur while following the streamline close to the barrier surface. The particles may have just enough momentum to touch the barrier and adhere. Very small particles ($d < 1 \mu\text{m}$) tend to follow the air movement very well and are extremely difficult to capture with control systems designed for impaction or interception mechanisms. These drops deposit on barriers mainly due to turbulent (Brownian) diffusion. The small random fluctuations of their movement in the air may bring them close enough to the barrier to touch and adhere (Bethea 1978). The more time they are near a barrier, the more chance they will be collected.

Most control devices are designed to collect particulate emissions by impaction or interception so that the majority of particles escaping these devices are submicron. To effectively collect these submicron particles, the control device must be designed to use collection by Brownian diffusion. Such a device would require a large barrier surface area and low gas velocities so the particles would be given adequate time to contact the barrier surface (Cheremisinoff and Young 1975). This design contrasts with the high velocity inertial mechanism type collection devices. Increasing the collection due to

diffusion would be done at the expense of the collection by the other two mechanisms, which is impractical because most of the pollutant mass is in the larger particles.

One option for designing a system to collect particles from all size ranges is to pretreat the gas stream before an impaction device to promote particle clumping and growth by agglomeration (Bethea 1978). As the particles grow, their chance for collection increases. A second option is to have two separate units, one to collect by impaction and interception followed by the other to collect by diffusion.

Available Control Devices

End-of-pipe control devices used for chromium electroplating and anodizing operations include chevron blade mist eliminators, packed bed scrubbers, mesh pad mist eliminators, composite mesh pad mist eliminators, fiber bed mist eliminators, and T-BACT (Best Achievable Control Technology for Toxics). The chevron blade mist eliminator, strictly an impaction device, contains a series of closely aligned metal blades used to abruptly change the air flow direction many times and provide a surface for the particles to impact. This device will usually not collect adequate numbers of particles to meet the recent federal compliance limit. The available devices listed below have the potential to meet these compliance limits.

Most of the modern control systems locate the blower at the end of the air path to pull emissions through the control device. This strategy has two principal advantages over systems that push emissions through the control device. First, the force of the pulling air creates a negative pressure drop at any leaks in the ventilation system, ensuring that fugitive emissions will not escape the control device. Second, the corrosive nature of chromic acid will reduce the life of the blower if it enters untreated. Older devices, such as the chevron blade mist eliminator, typically had the blower located before the control device because the control devices were less capable of removing the contaminant. If a blower was located after these older devices, an eventual buildup of chromic acid would form in the blower and be flung out into the atmosphere as large drops. This phenomenon is very noticeable when such large drops deposit on white cars in nearby parking lots.

Packed Bed Scrubbers

Packed bed scrubbers pass a stream of air through a wetted bed of packing material (Figure 1). The packing can come in various sizes and shapes, but must be constructed of an acid-resistant material. Packed bed scrubbers are usually used where adsorption is the main mechanism for collection. The large surface area of wetted packing

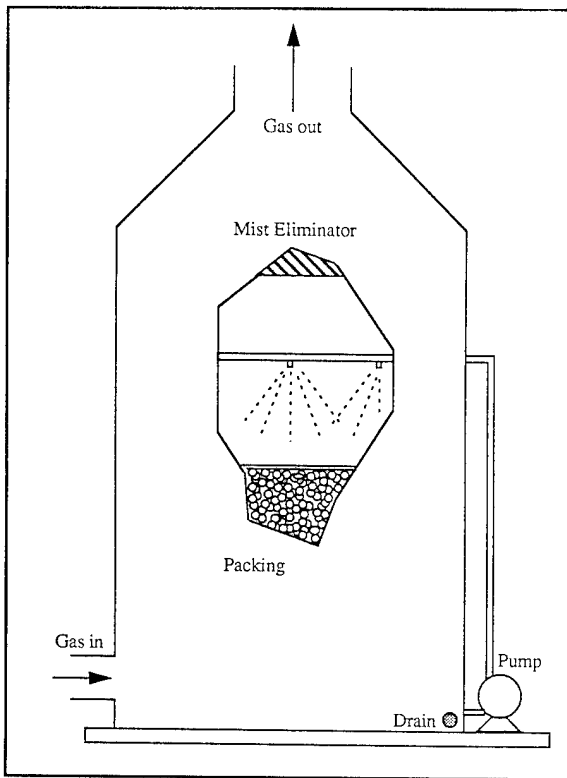

Figure 1. Packed bed scrubber.

provides a good media for collecting gaseous contaminants. The large surface area also makes these scrubbers good for collecting particulate matter such as chromic acid mist.

The large amount of water used to continuously wash down the packing material in these devices can cause a wastewater treatment problem. If the scrubber only services chromic acid emissions, some of the rinsewater can be used to make up the evaporative losses from the plating tanks, thereby recycling emissions.

Packed bed scrubbers have been used for years by the plating industry and have been considered the best end-of-pipe control method until the development of the composite mesh pad. A modern packed bed

scrubber, designated as the MACT for small, hard chromium electroplating sources, should at least meet the lesser standard imposed on small facilities. USEPA (July 1993a) claims a typical packed bed scrubber is capable of reducing emissions to 0.024 mg/dscm.

Composite Mesh Pad Mist Eliminators

A mesh pad mist eliminator contains filter elements consisting of closely woven fibers typically made of polypropylene. The closely packed thin fibers provide an excellent surface for the particles to adhere. This technology has been enhanced by the development of the composite mesh pad mist eliminator. This unit has a series of mesh pads with fiber thicknesses that can vary throughout each pad as well as from pad to pad to successfully collect a large range of particle sizes by impaction and interception. Figure 2 shows a schematic of a typical horizontal unit.

The composite mesh pad (CMP) mist eliminator is currently the end-of-pipe technology of choice for the plating industry. This is due to its effective emissions control and competitive cost. A typical composite mesh pad mist eliminator should be expected to reduce chromium emissions to 0.009 mg/dscm (USEPA, July 1993b).

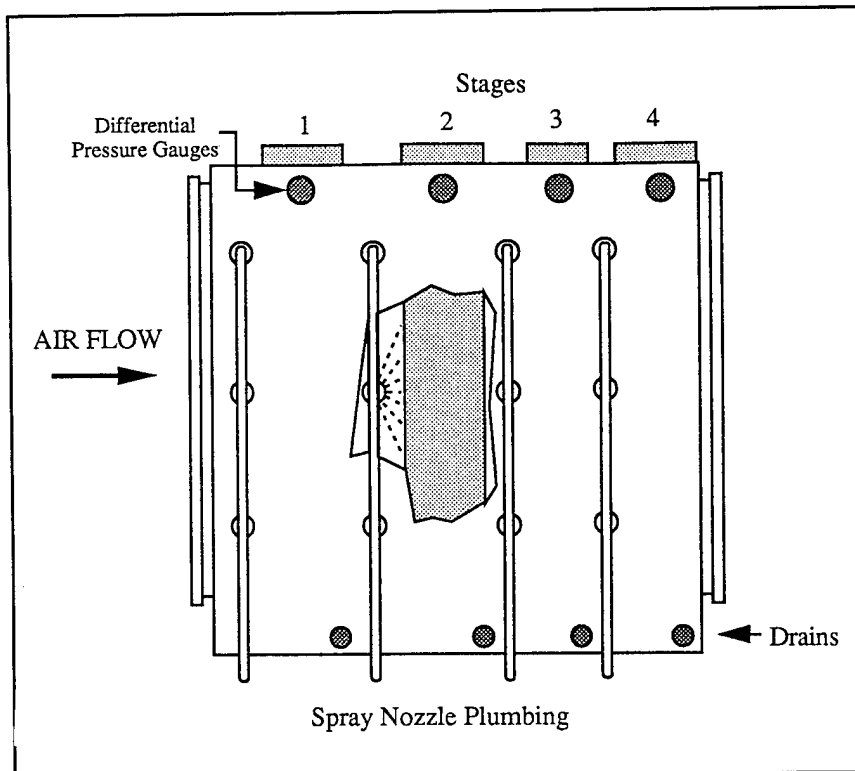

Figure 2. Horizontal four-stage composite meshpad unit.

CMP mist eliminators are equipped with spray headers for either continuous or periodic washdown. This is to keep the pads wet for better emission collection and to clean the pads to reduce the chances of plugging. Modern devices also allow for recycling the majority of the emissions back into the plating tank by collecting the washdown from the first stages. This helps minimize chromium replenishing and wastewater treatment costs.

Manufacturers have used various designs for this device while keeping the fiber material fairly consistent. Some design options vary the direction of flow through the pads (horizontal or vertical), the number of stages or pads, the arrangement of pads with differing fiber thicknesses and packing densities, the arrangement of spray headers, the frequency of wash down, and the option of a precontrol pad placed before the actual CMP unit. Some units combine a packed bed scrubber with a CMP section. Vertical units tend to allow a more even washdown and air flow distribution than the horizontal units, so that the entire air stream is treated consistently and effectively. However, vertical units do stand a larger chance of flooding if not designed properly. Generally speaking, the more efficient units will be vertical with many stages and high frequency or continuous washdown. A precontrol device is recommended to help extend the life of the pads.

Fiber Bed Mist Eliminators

The fiber bed mist eliminator is usually used for sulfuric acid mists, but has recently been adopted for use in controlling chromic acid mists. The control device contains one or more cylinders of packed fiber constructed of glass, ceramic, plastic, or metal. The fine closely packed fibrous material provides a large surface area to volume ratio to promote collection by inertial and interception mechanisms. A decreased gas velocity through the fibers also enhances collection by diffusion. These devices are washed down whenever the pressure drop increases beyond a certain value to avoid plugging. Figure 3 shows a hypothetical single-cylinder fiber bed mist eliminator to illustrate the concept underlying these devices.

Studies have shown that fiber bed mist eliminators can typically reduce chromium emissions to $0.1 \mu\text{g}/\text{dscm}$ (USEPA, July 1993b), well below the established emission standards. However, due to its relatively high capital and maintenance costs, installing a fiber bed mist eliminator is usually not cost effective. Reasonable emissions can be achieved with the less expensive composite mesh pad systems. In addition, the unit is better installed after an existing control device, such as a packed bed scrubber or composite mesh pad mist eliminator, to avoid plugging. This precontrol device would represent an additional cost.

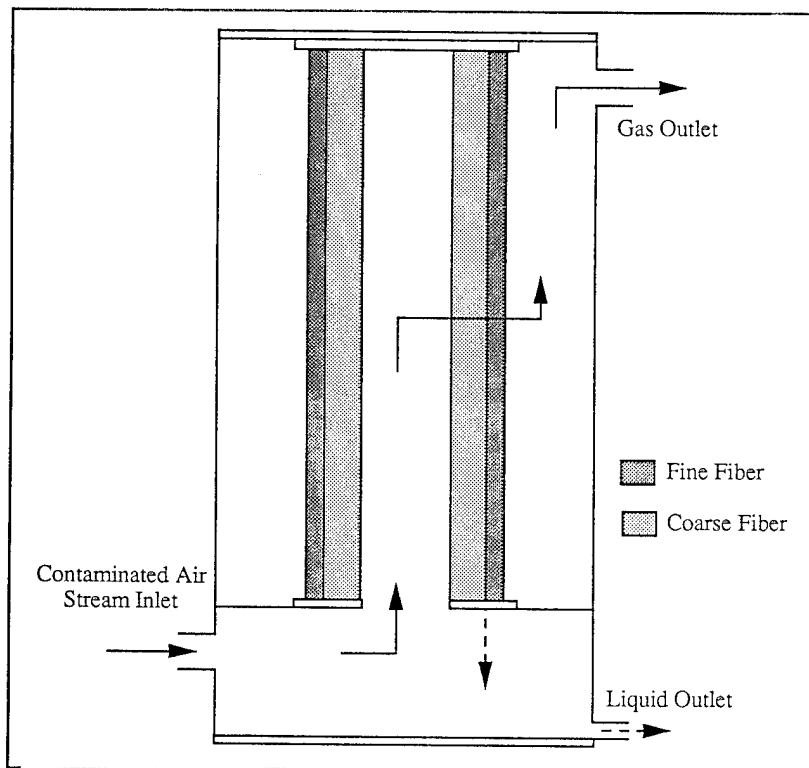

Figure 3. Cross-sectional view of a single cylinder fiber bed mist eliminator.

T-BACT

The South Coast Air Quality Management District, located around Los Angeles, California, has designated T-BACT as the recommended technology for chromium electroplating facilities in the district for complying with its strict regulations (High 1994). This control device usually consists of a two-unit process. The first is a composite mesh pad unit (usually vertical with two stages) to collect the majority of the entrained mist mass by impaction and interception followed by a high efficiency particulate air (HEPA) filter unit to eliminate the remaining submicron particles (Miles, Miles, and Michel 1995). Figure 4 shows the arrangement of the system. The HEPA filter is constructed of a glass fiber paper and is folded in an accordion style within the collection unit to maximize surface area and lower gas velocity through the filter to enhance the deposition of submicron particles by diffusion.

With proper design and maintenance, the HEPA filters could last up to 5 years before they need to be changed. Since this unit requires only a two-stage composite mesh pad unit, overall maintenance costs will tend to be lower than those for the typical four-stage unit. A complete T-BACT system would cost roughly the same as a four stage composite mesh pad system and would achieve higher efficiency. With a typical outlet concentration of about 0.05 $\mu\text{g}/\text{dscm}$ (Miles, Miles, and Michel 1995), this device is quite capable of meeting all regulations now and in the near future.

Despite this technology's potential, there are currently only two known firms that install it. As of July 1995, no military installations have installed this system.

Cost Comparisons

Table 3 summarizes the expected outlet concentrations and rough capital and annualized cost estimates for the four devices presented above. Actual costs can vary significantly depending on the facility, existing control ventilation system, control device manufacturer, and installing firm. Some capital and most annualized cost estimates (USEPA July 1993a, 1993b) were presented in 1988 dollars, but have been converted to 1995 dollars for this report. The detailed method used to determine these costs was used to calculate the additional cost data in Table 3. Cost estimates are for a new, medium size plant, defined by USEPA (July 1993a, 1993b) which has four tanks of varying sizes and a total control device ventilation rate of 990 m^3/min (35,000 $\text{cu ft}/\text{min}$). Existing facilities can expect to add 25 percent to the capital cost for retrofitting. Tables 4 and 5 list more detailed cost figures.

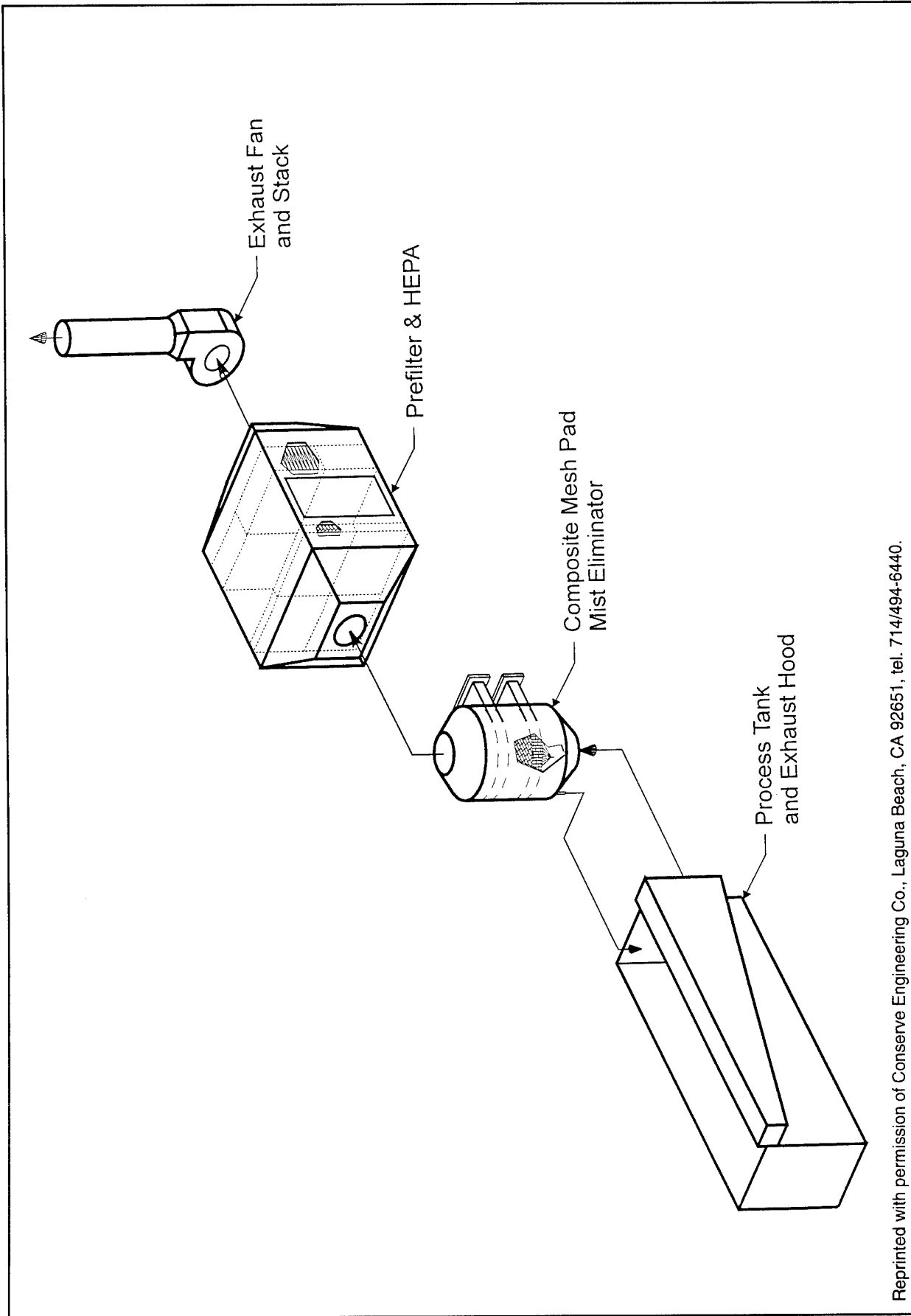

Reprinted with permission of Conserve Engineering Co., Laguna Beach, CA 92651, tel. 714/494-6440.

Figure 4. T-BACT system.

Table 3. End of pipe control device output concentrations and cost comparisons.

Control Device	Typical Output Concentration ($\mu\text{g}/\text{dscm}$) ^a	Capital Cost Estimates (\$k) ^b	Annualized Cost Estimates (\$k)
Packed Bed Scrubber ^c	24	81	20
Composite Mesh Pad Mist Eliminator	9 ^d	127 ^e	36 ^{d,f}
Fiber Bed Mist Eliminator	0.1 ^d	248 ^d	72 ^d
T-BACT System	0.05 ^g	125 ^h	31 ^h

a MACT standards for small and large facilities are 30 and 15 $\mu\text{g}/\text{dscm}$, respectively.
 b All costs are converted to 1995 dollars.
 c Single packed bed horizontal flow scrubber (USEPA July 1993a)
 d USEPA July 1993b
 e Vertical 4-stage CMP unit (Thomas E. Miles, General Manager, Conserve Engineering Co., Laguna Beach, CA (facsimile communication 11 September 1995)
 f Cost estimated for the mesh pad system described in USEPA (1993b) and not the 4-stage vertical system on which the capital cost is based
 g Vertical 2-stage CMP unit plus an HEPA unit (Miles, Miles, and Michel, June 1995)
 h John Michel, Project Engineer, Conserve Engineering Co., Laguna Beach, CA (facsimile communication) 8 September 1995

Table 4. Estimated capital costs for end-of-pipe control devices at a new facility.

	Packed Bed Scrubber ^{a,b}	CMP Mist Eliminator ^c	Fiber Bed Mist Eliminator ^d	T-BACT CMP/HEPA System ^e
Total purchased equipment ^f	47,300	103,800	167,300	104,400
Installation	26,400	22,300	59,700	19,300
Startup	500	1,000	1,700	1,000
Total capital cost ^g	74,200	127,100	228,700	124,700

a All costs rounded to nearest \$100. Add 25% to the total capital cost for retrofitting an existing facility. Cost analysis based on cost analysis described by USEPA (July 1993a, 1993b) for a medium size facility with a ventilation rate of 990 m^3/min (35,000 $\text{cu ft}/\text{min}$). Defining parameters for this facility given in Table 12, USEPA (July 1993b).
 b Costs in 1988 dollars for single packed bed horizontal flow unit (USEPA, July 1993a).
 c Costs in 1995 dollars for a 4-stage vertical composite mesh pad system (Miles 11 September 1995).
 d Costs in 1988 dollars (USEPA July 1993b).
 e Costs in 1995 dollars for a 2-stage vertical composite mesh pad unit plus a horizontal HEPA filter unit (Michel 8 September 1995).
 f Includes basic unit; plumbing and recirculation equipment; inlet and outlet transitions; fan and motor; stack; and sales tax and freight (added 8%).
 g Numbers may not sum exactly due to independent rounding.

Table 5. Estimated annualized costs for end of pipe control devices.

Cost Data in 1988 Dollars	Packed Bed Scrubber ^{a,b}	CMP Mist Eliminator ^c	Fiber Bed Mist Eliminator ^c	T-BACT CMP/HEPA System ^d
Utilities	3,800	7,300	11,300	7,300
Operator and maintenance labor	2,300	3,000	5,800	400
Maintenance materials	1,100	2,400	1,600	300
Media replacement ^e	400	4,800	9,900	4,500
Indirect costs ^f	5,000	6,100	13,500	5,200
Capital recovery	8,700	11,700	26,700	13,800
Annualized cost ^g	21,300	35,400	68,800	31,400
Chromic acid recovery ^h	(2,600)	(2,600)	(2,600)	(2,600)
Net annualized cost ^g	18,700	32,800 ⁱ	66,200	28,800

^a All costs rounded to nearest \$100. Cost analysis based on cost analysis described by USEPA (July 1993a, 1993b) for a medium size facility with a ventilation rate of 990 m³/min (35,000 ft³/min). Defining parameters for this facility are given in Table 12, USEPA (July 1993b).

^b Single packed bed horizontal flow scrubber (USEPA July 1993a).

^c Cost data from (USEPA July 1993b).

^d Two stage vertical composite mesh pad unit plus a horizontal HEPA filter unit (Michel 8 September 1995).

^e Includes cost of media, transportation, and disposal.

^f Includes overhead, property tax, insurance, and administration.

^g Numbers may not sum exactly due to independent rounding.

^h Based on control efficiency of 99.8 %.

ⁱ This cost is for the mesh pad system described in USEPA (July 1993b); *not* the four stage vertical system on which the capital cost is based.

If one assumes that the cost differentials between control devices translate to smaller facilities, the packed bed scrubber appears to be the most economical choice for small facilities. However, it does not seem to provide much insurance in the case of decreased regulatory standards. Large facilities can choose between the CMP, Fiber Bed, and T-BACT systems. The fiber bed system, as mentioned before, has an excellent control efficiency but represents a relatively large investment. The four stage vertical CMP system and the two stage CMP/HEPA system have practically identical costs, but the CMP/HEPA unit with its superb efficiency rating appears to be the best value.

6 Emission Reduction Techniques

One popular belief is that, by suppressing the chromium emissions at the tank level, less emissions will enter the end-of-pipe control device; consequently the output concentration from the device would be lower. Technologies and techniques to suppress emissions include chemical fume suppressants, plastic balls, and operational modifications. A study performed by the California Air Resources Board (Weintraub and Popejoy, June 1991) presents data showing that process modifications (specifically plastic balls, chemical fume suppressants, and elimination of air agitation) will significantly reduce emissions at the tank level and the entrance of an end-of-pipe control device. The data also suggests that, by reducing the inlet concentration, the final exit concentration exiting an end-of-pipe control device can also be reduced.

One comparison test with a packed bed scrubber tested with and without polyballs showed a 50 percent reduction in the exit concentration. Another test with the same scrubber showed a 60 percent reduction in the exit concentration when both polyballs and a fume suppressant were used. This conflicts with USEPA's opinion that end-of-pipe control device (mainly MACT, packed bed scrubbers and composite mesh pad mist eliminators) exit concentrations are independent of inlet concentrations (USEPA, July 1993b). In light of the conflicting results, the following emission reduction techniques may be helpful in bringing a facility into compliance, especially when the facility's emissions do not meet the standard, but are very close. If they do not bring final concentrations down, they will at least help reduce corrosion and cleaning frequency in the ventilation system and control device.

Additional techniques that may help reduce final emission concentrations involve retrofitting and repairing existing control devices to operate at peak efficiency. There is also a unique tank cover device on the market that is capable of suppressing emissions without the need for an extensive ventilation system.*

* The "Merlin Mist Control Device," manufactured by Merlin Enterprises, 7682 Everest Circle, Huntington Beach, CA 92647-3016, tel. 714/897-9565.

Chemical Fume Suppressants

There are three kinds of chemical fume suppressants: (1) a foam blanket, (2) a surface tension modifier, and (3) a combined foam blanket and surface tension modifier. Generally, chemical fume suppressants are used more in the decorative chromium electroplating industry because the addition of chemicals to a chromium electroplating solution can adversely affect the performance of a hard chromium application. The foam blanket is a chemical additive that uses the gases generated in the electroplating process to create a layer of foam at least 2.5 cm thick. The blanket provides multiple barrier surfaces with which to collect the mist before being released to the air. Foam blankets have the disadvantage that they can trap the byproduct hydrogen and oxygen gases, thereby forming an explosive mixture. This is a safety hazard, especially for shops that remove parts from the plating tanks with the current still applied. Foam blankets cost between \$10 and \$65 per pound of solution with an average recommended mixing ratio of 1 oz to every 500 gal of plating solution. Deterioration of foam blankets is mostly caused by dragout (Reed 1995).

An experiment was performed at Anniston Army Depot to determine whether the addition of a certain foam blanket fume suppressant (Fumetrol 101) would help reduce emissions without affecting the performance of the plating operation.* Stack emission tests were to be taken with and without the additive. Preliminary testing showed that the fume suppressant aggravated pitting in the plating parts; consequently, the remaining tests were canceled. It was noted, however, that there was a visible reduction in mist above the tank after the fume suppressant was added.

The surface tension modifier is a chemical additive that reduces the surface tension of the plating solution. A lower surface tension reduces the force with which bubbles burst at the solution surface so the solution generates fewer emissions. In addition, a lower surface tension will reduce the chromic acid dragout when parts are removed from a tank. Surface tension modifiers also introduce a chemical change to the plating solution, which can lead to negative effects on finished plated parts. These effects could include burning, pitting, cloudiness, or poor adhesion. Surface tension modifiers cost about \$25 to \$30 per gal and generally do not last as long as foam blankets (Reed 1995).

Fume suppressants can capture efficiencies above 99.3 percent (USEPA, July 1993a). Using a fume suppressant alone may be enough to reduce the chromic acid emissions below the MACT standard. Unfortunately, their adverse effect on the plating solution

* Fumetrol 101 is one of several fume suppressants manufactured and marketed by Atotech USA, Inc., Somerset, NJ 08875-6768, tel. 908/302-3538.

chemistry limits their use to decorative chromium electroplating and chromium anodizing. The fume suppressant industry is continuously improving their products; it is possible that a newer product is currently or will soon be available that will effectively control emissions without adversely affecting plating quality.

Plastic Balls

A layer of plastic (usually polypropylene) balls about 30 mm in diameter can be floated on the plating solution to provide a surface for the mist to deposit and drain back into the plating solution. Plastic balls cost about \$0.15 per ball and can last for several years (Reed 1995), making for an inexpensive emission reduction technique.

There are two main disadvantages to the use of plastic balls. First, there is a tendency for the balls to be pushed away from the electrodes by the surface disturbances caused by the rising bubbles. Unfortunately, this is where the balls are needed the most to reduce emissions. Second, there is a tendency for the balls to get caught in parts and racks. When workers remove the racks from the tanks, the balls can fall on the plating shop floor requiring replacement in the plating tank. In addition to this nuisance, handling the balls can promote horseplay among workers, who often give in to the temptation to throw the balls at each other.

The use of polypropylene balls can achieve typical emission removal efficiencies of about 75 percent (USEPA, July 1993a). By removing the majority of generated emissions, plastic balls can act as an effective precontrol device. However, they will not adequately control emissions to meet the regulated standards alone.

An experiment done at Anniston Army Depot as part of this study supports the suggestion made by Weintraub and Popejoy (1991) that polyballs can reduce final exit concentrations from an end-of-pipe control device by significantly reducing inlet concentration into the device (USAEHA 1995). Two sets of three emissions samples were taken using USEPA Method 306 (an accepted test method for demonstrating compliance with the NESHAP). With the first set, the plating line was configured using only the existing end-of-pipe control device (a mist eliminator). The second set included plastic balls in addition to the existing control device. The results show that the average exit concentration was more than halved by the addition of polypropylene balls.

Operation Practices

The following four modifications to a facilities operations will help reduce chromium emissions generated at the tank level. The first three were suggested in a lecture given by K.R. Newby (Atotech USA, Inc., presentation at the American Electroplaters and Surface Finisher's Chromium Summit, Chicago, IL, 25 May 1995).

1. Air agitation can be replaced by a circulation pump. Creating more bubbles in the plating solution can only increase the amount of emissions generated at the plating solution surface.
2. Lowering the level of plating solution (increasing the free board height) will provide a greater distance for the mist to escape. This will allow more of the mist to deposit or fall back into the solution before being ventilated, thereby decreasing emissions escaping from the tank.
3. Lowering the current density will result in a lower emission rate based on mass per unit air flow rate due to a decreased plating efficiency.
4. Covering the unused portion of a plating tank will help reduce fugitive emissions and increase ventilation capture efficiency. This could also allow for lower ventilation flow rates to save energy costs.

It is important to reiterate that the operational modifications listed here can be specifically used to reduce the emissions at the plating tank level. These could be used by a facility that needed only a slight final emission reduction to meet limits. As mentioned before, the USEPA regulation is based on the weak assumption that the MACT technology or other modern end-of-pipe control devices will emit the same concentration regardless of input concentration. Due to the uncertainty of this assumption, it may be worth trying one or more of these ideas.

Control Equipment Optimization

Optimizing current emission control devices is a very practical way to help reduce final exiting emissions. Optimizing should include ensuring that no air leaks exist in existing ventilation equipment and that there are no gaps in the packing media, especially around the edges. A thorough check and repair is necessary to ensure that no emissions escape the control medium and exit untreated. Fugitive emissions will dramatically increase actual emission rates. The pressure drop through a device should be kept within manufacturer's specifications. Control mediums such as filters, packing material, or mesh pads should be rinsed and replaced periodically. Faulty spray headers should be replaced. Air flow rates should also be kept within manufacturer's specifications. Too low an air velocity will allow excess emissions to escape

through a filter (a result of less direct impaction); too high an air velocity will encourage re-entrainment of trapped liquid into the air flow.

Tank Cover

A tank cover currently on the market (the "Merlin Mist Control Device") appears to be an optimum solution by allowing the chromic acid mist to simply condense and settle back into the plating solution. A Teflon filter is located at the top of the cover to allow for the generated gases to escape. These small molecules can penetrate the filter while the chromic acid mist does not. Allowing the gases to escape reduces the explosion hazard and the pressure buildup under the cover. A large disadvantage of this system is the difficulty in placement and removal of parts to and from the cover of the tank. The tank must be uncovered to place parts into the tank and then recovered. When the parts are ready, the current must be turned off and the contaminated air under the cover is drawn out and treated by a small filter system before being exhausted to atmosphere. After the air has been treated the cover may be lifted and the parts removed. The biggest advantage to this system is the elimination of an extensive ventilation system; despite this, the capital cost is roughly \$25,000 per tank for a typical chromium electroplating tank. This device is probably most suited for facilities with one or two small tanks plating parts for long durations.

7 Venturi/Vortex Closed-Loop Scrubber Technology

“New types of separators have occasionally appeared on the market with ostensibly quite unheard-of separating efficiencies. Unfortunately, none of these ‘wonder separators’ have yet been able to establish themselves in practice. This means that we must still depend on finding the most suitable separator for the particular separating problem. The smaller the particles to be separated, the larger are the costs for investment and energy. There are no tricks for avoiding this rule.” (Bragg and Strauss 1981). This statement is both a challenge and a warning when pursuing new technologies for abating chromic acid mist from chromium electroplating tanks.

Huston (1993) tested a new technology involving a baffle system, in which the baffles were spaced 0.7 cm apart with 0.6 cm diameter holes drilled throughout. Bench tests yielded removal efficiencies of only 76 percent, which is inadequate for meeting the MACT standard. This device does not offer the necessary flow barriers to collect small particles. While most modern end-of-pipe control devices are capable of meeting the MACT standard, there is still a desire to achieve compliance level emission concentrations by using an inexpensive and easily installed device. The venturi/vortex closed loop scrubber is a new technology that may achieve this goal.

Description

Figure 5 shows a diagram of the venturi/vortex closed loop scrubber. A patented drain located at the plating solution surface pulls plating solution down by a gravity-generated vortex effect, consequently drawing the air and emissions above the drain down as well. The fumes are scrubbed by the solution as the two-phase mixture travels down the drain pipe and into a heated separation tank. Roughly 95 percent of the fumes are captured at this point. The remaining fumes are forced through a secondary scrubber/condenser consisting of heat exchangers packed with polypropylene fibers to remove the remaining particles. The cooling heat exchangers promote growth by condensation of the small particles so that collection is more effective. The small gas flow rate exiting the secondary scrubber is allowed to vent to atmosphere. The plating solution is circulated between the separation tank and the plating tank, creating a closed loop effect that recycles the emissions.

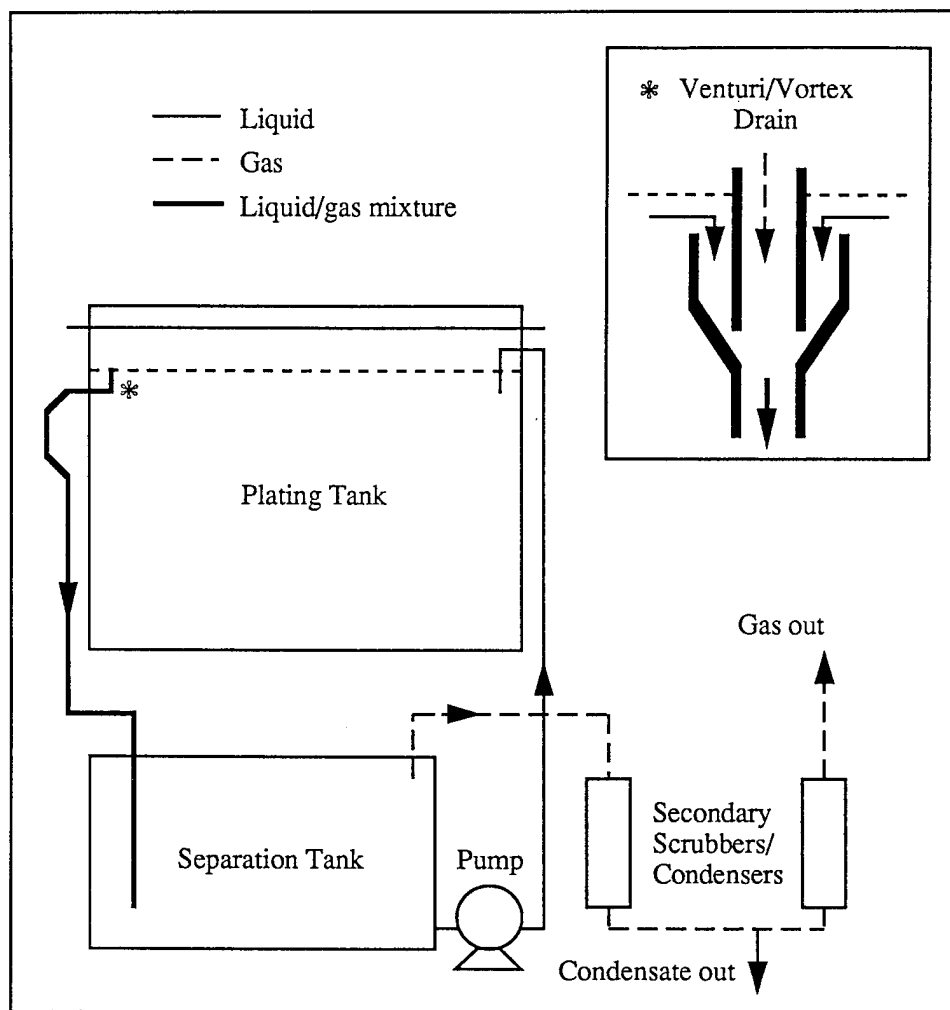

Figure 5. Venturi/vortex closed-loop scrubber.

The device can be applied to any size tank by varying the number and size of venturi/vortex drains. The separation tank would be designed to contain the appropriate displaced solution when parts are submerged in the plating tank. Compared to extensive ventilation systems and end-of-pipe control devices, preliminary tests show that this system offers several advantages over other systems:

1. Costs less than 50 percent of other systems
2. Lower maintenance and operational costs
3. Significantly less production of wastewater
4. Little if any evaporative losses from the plating tank
5. Easy retrofit to existing tanks.

A disadvantage to this system is that the accompanying (loose) lid covers the plating tank. This may cause a problem of inconvenience for facilities requiring frequent part removal.

A disadvantage to this system is that the accompanying (loose) lid covers the plating tank. This may cause a problem of inconvenience for facilities requiring frequent part removal.

Preliminary tests have shown the device is capable of reducing the chromic acid emissions to 0.016 μg per amp hr. (The current California State requirement, generally regarded as one of the strictest chromic acid regulations, is 0.006 mg per amp hrs.) However, this technology may still have trouble meeting the MACT standard because the air flow rate through the device is small. The total mass rate of released chromium would most likely be significantly less than that released by MACT, but the concentration may be higher. Regulations allow the USEPA to recognize the capabilities of an alternative technology and grant for an exception to their concentration-based compliance limit.

Plans for Testing and Technology Transfer

As part of this study, a venturi/vortex closed loop scrubber is being designed and constructed for installation at the Vessel Plating Area of Benet Laboratories, NY. The pilot testing will be performed on a 1000-gal chromic acid electroplating tank with a rectifier capacity of 2500 Amps. The system will be modified to achieve optimal performance and tested to define its capabilities in controlling harmful emissions. Testing is scheduled to take place by the end of November 1995. Results of these experiments will be presented in a final technical report.

If the pilot testing is successful, a demonstration site will be sought. The upcoming regulation deadline of 25 January 1997 will provide motivation to speed the demonstration stage so that the technology may be available in time. It is more likely that the device will be available to installations constructing new facilities or modernizing existing operations some time after the demonstration phase, or to installations that have been granted a compliance extension by the USEPA.

8 Compliance Recommendations

General

Chromium electroplaters and anodizing facilities may choose from five basic options* to meet the federal, or any other (e.g., state), compliance limits:

1. Install new and effective air pollution control equipment
2. Renew or adjust existing control devices to achieve compliance limit
3. Use emission reduction practices (at tank) to achieve compliance
4. Replace chromium electroplating with an alternative production process
5. Discontinue operation.

In the long run, the fourth option is the best, however, a satisfactory replacement for hard chromium electroplating that provides all the beneficial characteristics of chromium is not currently available. A trivalent chromium process is currently available for decorative chromium and a trivalent hard chromium process is being developed. Other types of electroplating or surface coatings that may be an option include: non-chromium metals and alloys, electroless plating, chemical vapor deposition, thermal spraying, vacuum coating, and surface hardening. Although it is highly recommended that other processes should be considered as alternatives to current electroplating operations, it is recognized that it is difficult for Army installations to consider due to part specifications.

Discontinuing operations (Option 5) may be a viable choice for a small electroplating for anodizing operation with little or no air pollution control equipment. Under such circumstances, contracting the work to either another military facility or commercial facility may offer cost advantages over the purchase and installation of new pollution control devices or production equipment.

Since repairing old systems and practicing emission reduction techniques will usually be less expensive, option one, installing new equipment, should only be considered after options two and three are exhausted. Any combination of options one, two, or three is recommended. More detailed discussion of these options follows.

* The first four are attributed to Newton (1995).

Hard Chromium Electroplating Facilities

The following options are recommended to help hard chromium electroplating facilities meet compliance limits:

1. If existing equipment is close to compliance, repairing and optimizing it could bring the equipment into compliance. For example, correcting faulty spray headers and gaps in the packing media, especially around the edges can significantly improve in a control device's efficiency.
2. In the case of a "near miss" of the compliance limit, process modifications such as eliminating air agitation, increasing freeboard height, decreasing current density, and covering unused tank portions may help reduce emissions at the tank level.
3. Reducing emissions into an existing control device using a precontrol device, such as a single mesh pad located just after the ventilation slots, can perhaps reduce the output concentration from an end-of-pipe device. It will at least slow the rate of corrosion of the entire ventilation system.
4. A fume suppressant that is compatible with hard chromium electroplating operations can be used either alone or in conjunction with an existing control device.
5. If the operational usage is close to but above 60 million amp-hr/yr, reducing and documenting the usage below this cutoff would change a facility's classification from large to small, thereby making the MACT standard easier to meet.
6. If existing air pollution control equipment is far from compliance or there is no existing control equipment, installing new control equipment will be a good but expensive choice to reach compliance. Depending on the existing equipment, either a complete system or an add-on device may be installed. The recommended unit for all facilities is the T-BACT system; however the packed bed scrubber does offer a cost effective alternative for small facilities. If it is feasible to have a fixed lid on a tank at a small one or two tank facility that processes parts for long durations, then consideration should be given to the elaborate tank cover. Users should ensure that any chosen device comes with a written guarantee from the vendor to meet compliance. Users should also seek equipment that offers the lowest possible guaranteed output concentration in anticipation of more stringent future regulations.
7. An application for an extension should be submitted if more time is needed.

Chromium Anodizing Facilities

The following recommended options may help chromium anodizing facilities meet compliance limits:

1. If a facility cannot use a fume suppressant, it should consider implementing the options listed above for chromium electroplating facilities.
2. Using a surface tension modifier to lower surface tension and meet the surface tension compliance limit is an easy, inexpensive way to comply.
3. Using a combination surface tension modifier and foam blanket may further reduce emissions.
4. An application for an extension should be submitted if more time is needed.

9 Summary and Recommendations

Summary

Federal and State agencies have targeted hard chromium electroplating operations as a major source of toxic hexavalent chromium emissions and have subsequently regulated the industry. Of the eight Army installations with hard chromium electroplating and/or chromium anodizing operations, the two largest facilities claim to be currently in compliance; four more are currently planning to install MACT to achieve compliance; and the remaining two expect to achieve compliance by the deadline.

Hard chromium electroplaters and anodizers must meet compliance limitations by 25 January 1997, but may select their own control equipment. Four available end-of-pipe control devices can help electroplaters and anodizers meet the MACT compliance limits:

1. The packed bed scrubber (a cost-effective choice for small facilities)
2. The composite mesh pad
3. The fiber bed mist eliminator
4. T-BACT (the most cost-effective end-of-pipe device for large facilities).

Although there is some disagreement whether modern end-of-pipe technologies can yield constant outlet concentrations, several inexpensive technologies and techniques will reduce emissions at the tank level and perhaps at the outlet of an existing end-of-pipe control device:

- plastic balls
- fume suppressants
- process modifications
 - eliminating air agitation
 - increasing freeboard height
 - decreasing current density
 - covering unused tank portions.

One available tank cover claims to be a complete pollution control device. The device eliminates extensive ventilation equipment but has limited potential use.

Pilot testing of one new technology, the Venturi/Vortex Closed Loop Scrubber, should conclude by late calendar year 1995. This technology may offer the potential for superior fume collection (while recycling emissions) at a significantly lower cost than current end-of-pipe control technologies.

Also, the USEPA has a current program under the *Common Sense Initiative* to find quick, economical ways to bring chromium electroplaters into compliance, and to see if the imposed compliance concentration limit is reasonably achieved. If documented study shows that it cannot be reasonably achieved, it is possible that the regulation may be modified. Results from both studies should be available in early 1996.

Recommendations

Several options are currently recommended for chromium electroplating and anodizing facilities to achieve compliance. Anodizers should strongly consider meeting the surface tension limit using a fume suppressant. Hard chromium electroplaters should try to optimize existing control equipment, use inexpensive emission reduction technologies, or consider process modifications in cases where there is a "near miss" of the compliance limit. If emissions far exceed the limit with existing equipment, then new equipment should be installed that (at a minimum) guarantees compliance.

References

- Altmayer, F., "Chromium MACT Facts," *Plating and Surface Finishing* (February 1995), pp 26-27.
- Altmayer, F., "Chromium MACT-Part II," *Plating and Surface Finishing* (March 1995), pp 34-35.
- Altmayer, F., "The Clean Air Act and Chromium Emissions," *Plating and Surface Finishing* (July 1992), pp 30-32.
- Bar, R., "Surpassing Chromium Emission Standards," *Products Finishing* (July 1993), pp 60-64.
- Bethea, R.M., *Air Pollution Control Technology* (Litton Educational Publishing, Inc., 1978), pp 7-13.
- Bragg, G.M. and W. Strauss, eds., *Air Pollution Control, Part IV* (John Wiley & Sons, 1981).
- Cheresminoff, P.N., and R.A. Young, eds., *Pollution Engineering Practice* (Ann Arbor Science Publishers, Inc., 1975).
- Code of Federal Regulations (CFR), title 29, part 1910, section 94.
- Federal Register (FR), vol 58, p 65768.
- Federal Register (FR), vol 60, p 4948.
- High, M.D., "Regulation of Chromium Emissions in California," *Chromium Colloquium* (American Electroplaters and Surface Finishers [AESF], 1994).
- Huston, C., "Alternatives to MACT: Chromium Air Emission Reduction Strategies," *Plating and Surface Finishing*, vol 80 (November 1993), pp 48-49.
- Miles, T., D. Miles, and J. Michel, "Meeting the New Chromium Air Emissions Standards With T-BACT," Paper presented at the *AESF Sur/Fin '95* (AESF, June 1995).
- Nelson, B., *Chromium Electroplating Alternatives in Aerospace Applications* (National Defense Center for Environmental Excellence [NDCEE], February 1995a).
- Nelson, B., *Chromium Electroplating Alternatives in Heavy Equipment Applications* (NDCEE, February 1995b).
- Newton, D., *National Emission Standards for Chromium Emissions From Hard and Decorative Chromium Electroplating and Chromium Anodizing Plants: Compliance Guide* (Naval Facilities Engineering Center, 25 January 1995).

- Powers, W.E., *Air Pollution Control Equipment for Selected Plating Shop Processes Based on Emission Test Results* (Naval Energy and Environmental Support Activity, 1985 est.).
- Reed, D., *Air Pollution Compliance Evaluation of Chromium Electroplating*, Draft Technical Report (U.S. Army Center for Health Promotion and Preventive Medicine, July 1995).
- United States Code (USC), title 42, section 7412 (15 November 1990).
- U.S. Army Environmental Hygiene Agency (USAEHA), *Air Pollution Emission Assessment No. 42-21-M3L3-95, Chromium Plating Facility, Anniston Army Depot, AL, 18-27 October 1994* (April 1995).
- U.S. Environmental Protection Agency (USEPA), *Chromium Emissions from Chromium Electroplating and Chromic Acid Anodizing Operations—Background Information for Proposed Standards*, 453/R-93-030 (July 1993a).
- USEPA, *Technical Assessment of New Emission Control Technologies Used in the Hard Chromium Electroplating Industry*, 453/R-93-031 (July 1993b).
- USEPA, *A Guidebook on How To Comply With the Chromium Electroplating and Anodizing National Emission Standards for Hazardous Air Pollutants*, 453/B-95-001 (April 1995).
- von Szilassy, P., *Quantification of Chromium Plating Usage in the U.S. Army*, Versar project No. 23050-001 (Versar Inc., 21 July 1995).
- Weintraub, F.R., and C.A. Popejoy, "A Systems Approach to Controlling Chrome Electroplating Emissions," *Proceedings of the 84th Annual Meeting & Exhibition* (Air & Waste Management Association [AWMA], June 1991), pp 91-103.

Abbreviations

AMC	U.S. Army Materiel Command
CAAA	Clean Air Act Amendments of 1990
CMP	Composite Mesh Pad
ESL	Effects Screening Level
FORSCOM	U.S. Army Forces Command
FS	Fume Suppressant
GLC	Ground Level Concentration
HEPA	High Efficiency Particulate Air
MACOM	Major Command
MACT	Maximum Achievable Control Technology
NDCEE	National Defense Center for Environmental Excellence
NESHAP	National Emission Standard for Hazardous Air Pollutants
OSHA	Occupational Safety and Health Administration
PBS	Packed Bed Scrubber
T-BACT	Best Achievable Control Technology for Toxics
TLV	Threshold Limit Value
TRADOC	U.S. Army Training and Doctrine Command
USEPA	U.S. Environmental Protection Agency

USACERL DISTRIBUTION

Chief of Engineers
 ATTN: CEHEC-IM-LH (2)
 ATTN: CEHEC-IM-LP (2)
 ATTN: CECG
 ATTN: CECC-P
 ATTN: CECC-R
 ATTN: CECW
 ATTN: CECW-O
 ATTN: CECW-P
 ATTN: CECW-PR
 ATTN: CEMP
 ATTN: CEMP-E
 ATTN: CEMP-C
 ATTN: CEMP-M
 ATTN: CEMP-R
 ATTN: CERD-C
 ATTN: CERD-ZA
 ATTN: CERD-L
 ATTN: CERD-M
 ATTN: CERM
 ATTN: DAEN-ZC
 ATTN: DAIM-FDP
 ATTN: SFIM-AEC-EPD

CECPW 22310-3862
 ATTN: CECPW-E
 ATTN: CECPW-FT
 ATTN: CECPW-ZC

US Army Engr District
 ATTN: Library (41)

US Army Engr Division
 ATTN: Library (11)

USA TACOM 48397-5000
 ATTN: AMSTA-XE

Defense Distribution Region East
 ATTN: DDRE-WI 17070

US Army Materiel Command (AMC)
 Alexandria, VA 22333-0001
 ATTN: AMCEN-F
 Installations: (20)
 Anniston Army Depot, AL 36201-5048
 ATTN: SDSAN-DPW-RAD
 Corpus Christi Army Depot, TX 78419-5260
 ATTN: SDSCC-IS
 Lake City Army Ammunition Plant, MO 64051-0250
 ATTN: SMCLC (EN-1A)
 Letterkenny Army Depot, PA 17201-4150
 ATTN: SDSLE-EN
 Picatinny Arsenal, NJ 07806-5000
 ATTN: AMSTA-AR-PSR
 Red River Army Depot, TX 75507-5000
 ATTN: SDSRR-WE
 Rock Island Arsenal, IL 61299-5000
 ATTN: SMCRI-SEM
 Stratford Army Ammunition Plant, CT 06497-7554
 ATTN: Air Compliance Manager
 Watervliet Arsenal, IL 12189-4050
 ATTN: SMCVW-PWQ

USA Natick RD&E Center 01760
 ATTN: STRNC-DT
 ATTN: DRDNA-F

US Army Materials Tech Lab
 ATTN: SLCMT-DPW 02172

CEWES 39180
 ATTN: Library

CECRL 03755
 ATTN: Library

USA AMCOM
 ATTN: Facilities Engr 21719
 ATTN: AMSMC-EH 61299
 ATTN: Facilities Engr (3) 85613

USA Engr Activity, Capital Area
 ATTN: Library 22211

US Army ARDEC 07806-5000
 ATTN: AMSTA-AR-IMC

Engr Societies Library
 ATTN: Acquisitions 10017

Defense Logistics Agency
 ATTN: DLA-WI 22304

US Military Academy 10996
 ATTN: MAEN-A
 ATTN: Facilities Engineer
 ATTN: Geography & Envr Engrg

Naval Facilities Engr Command
 ATTN: Facilities Engr Command (8)
 ATTN: Naval Facilities Engr Service Center 93043-4328

Tyndall AFB 32403
 ATTN: HQAFCEA Program Ofc
 ATTN: Engrg & Srvc Lab

US Army CHPPM 21010
 ATTN: HSHB-ME
 ATTN: MCHB-DE-AP

American Public Works Assoc. 64104-1806

US Gov't Printing Office 20401
 ATTN: Rec Sec/Deposit Sec (2)

Nat'l Institute of Standards & Tech
 ATTN: Library 20899

Defense Tech Info Center 22060-6218
 ATTN: DTIC-O (2)