

SMALL BUSINESS GUIDEBOOK TO QUALITY MANAGEMENT

DISTRIBUTION STATEMENT B
Approved for public release
Distribution Unlimited



19960305 026

Office of the Secretary of Defense
Quality Management Office
Washington, D.C. 20301-3016

SMALL BUSINESS GUIDEBOOK TO QUALITY MANAGEMENT

DISTRIBUTION STATEMENT A
Approved for public release
Distribution Unlimited



Office of the Secretary of Defense
Quality Management Office
Washington, D.C. 20301-3016

DISCLAIMER NOTICE

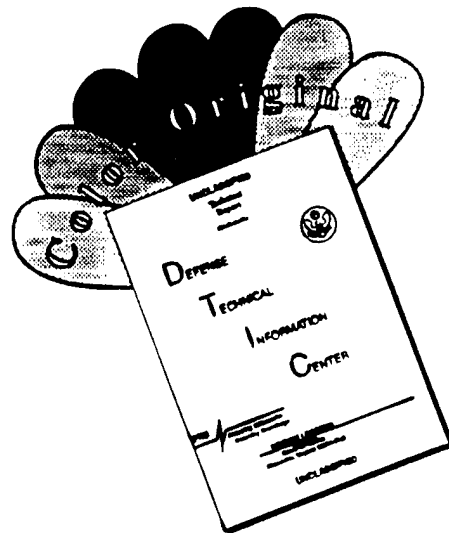

THIS DOCUMENT IS BEST QUALITY AVAILABLE. THE COPY FURNISHED TO DTIC CONTAINED A SIGNIFICANT NUMBER OF COLOR PAGES WHICH DO NOT REPRODUCE LEGIBLY ON BLACK AND WHITE MICROFICHE.

TABLE OF CONTENTS

LIST OF FIGURES AND TABLES	iii	CHAPTER 6—CONTINUAL PROCESS	
FOREWORD	v	IMPROVEMENT	31
CHAPTER 1—INTRODUCTION	1	Constant Change	31
Small Business and Quality	1	Customers and Suppliers	31
Background	4	Voice of the Customer/Voice of the Process	33
ISO 9000	6	The Loss Function	34
Current Reality	6	Problem Solving and CPI	35
CHAPTER 2—THE DEMING PHILOSOPHY	9	Variation	36
The Man and His Legacy	9	Three Immediately Useful Tools	38
The Fourteen Points	10	Flowcharts	38
The Deadly Diseases	11	Run Charts	40
The Obstacles	12	Control Charts	45
Profound Knowledge	13	Other Tools	47
CHAPTER 3—PLANNING	17	Cause and Effect Diagrams	47
PDSA Cycle	17	Brainstorming	49
Aim	18	Checksheets	49
Values and Guiding Principles	18	Histograms	50
Mission	19	Pareto Charts	50
Objectives	19	Measurement	51
Transformation	20	CHAPTER 7—STRATEGIES	53
Recharging the Infrastructure	20	Begin the Transformation	53
Leadership's Roles and Responsibilities	20	A Last Word	54
CHAPTER 4—TEAMWORK	23	ENDNOTES	55
Competition or Cooperation?	23	APPENDIX	
Empowerment	24	A. Glossary	57
CHAPTER 5—TEAMS AND MEETINGS	27	B. Suggested Further Reading	59
Framework for Action	27	C. Some Detailed PDSA Steps	61
Meeting Management	28	D. Control Chart Tests	63
The Group Mind	29	E. Bibliography	65
Membership Criteria	30		

FOREWORD

The aim of this guidebook is to help small businesses make the transition to a quality culture. The Federal Government, and the Department of Defense (DoD) in particular, are now in the middle of this transition. It seems important for those small businesses who now do business with the DoD, and for those who would like to do business with DoD, to get on line with the rapidly spreading quality movement. It is this focus that prompted the DoD to produce this publication.

Deming experts, William Scherkenbach and Heero Hacquebord, helped assure the accuracy of the content. Their patience and creative suggestions, in particular, have hopefully made this both a useful and user-friendly guidebook.

Inquiries related to this handbook should be directed to William Bloom, Program Manager, OSD Quality Management Office, Room 3A345, Pentagon, Washington, DC 20301-1155.

CHAPTER 1

INTRODUCTION



SMALL BUSINESS AND QUALITY

There are more than 20 million small businesses in the United States. Small businesses are a major force behind our economy. They employ more than half the private sector workforce in this country. Between 1980 and 1986, 64 percent of the 10.5 million jobs created in the U.S. were produced by small businesses.¹ Small companies are now operating in one of the most dynamic economic periods in American history. The list of current concerns for all business managers includes the usual factors: sales, profits, costs, schedules, deadlines, labor-management agreements, suppliers, and competition. The last decade has added other concerns like increased government reporting, increased global competition, increased complexity to government procurement, rising health care costs, and new government-mandated programs. Perhaps the overriding challenge of the past several years, however, has been the prolonged recession and the gradual, sluggish nature of the economic recovery. For many small business owners, these increasing business concerns have become critical issues in the fight for survival. How does one meet all these challenges?

According to a 1992 Gallup survey of 634 small businesses,² the recessionary environment is the biggest survival challenge these companies face. The surveyed businesses indicated that they have attempted to meet this challenge by one of four different strategies: improving quality, improving productivity, adding new products/services, or purchasing new equipment. Of the four options, the new initiative most often taken by responding

companies was quality improvement. However, a striking result can be observed by looking at company size and the choice taken (See Figure 1.). Twenty-eight percent of the survey's respondents with 1 to 20 employees worked to improve quality over choosing the other three options. The percentages of firms reporting a commitment to quality improvement were progressively higher for larger businesses: 43 percent of firms with 21 to 100 employees and 57 percent of companies with 101 to 500 employees.³ The strategy of improving quality to meet the survival challenge was more prevalent in larger companies. This should send a message to smaller firms.

The pressure to improve quality does not come just from necessity for small businesses. Customers are demanding more quality-consciousness and cost-efficiency from their suppliers. Tom Klobucher, owner of Thomas Interior Systems Inc., put it this way: "Any company that is not involved in some sort of quality process is already out-classed. If they don't begin to learn the quality language and quality life, they will be out of business."⁴

The federal government and, in particular, the Department of Defense (DoD) have been evolving more and more into quality-consciousness, not only with the activities of agencies and their internal organizations but increasingly with regards to their suppliers: large and small businesses. As shown above, smaller businesses are lagging behind in the movement toward quality.

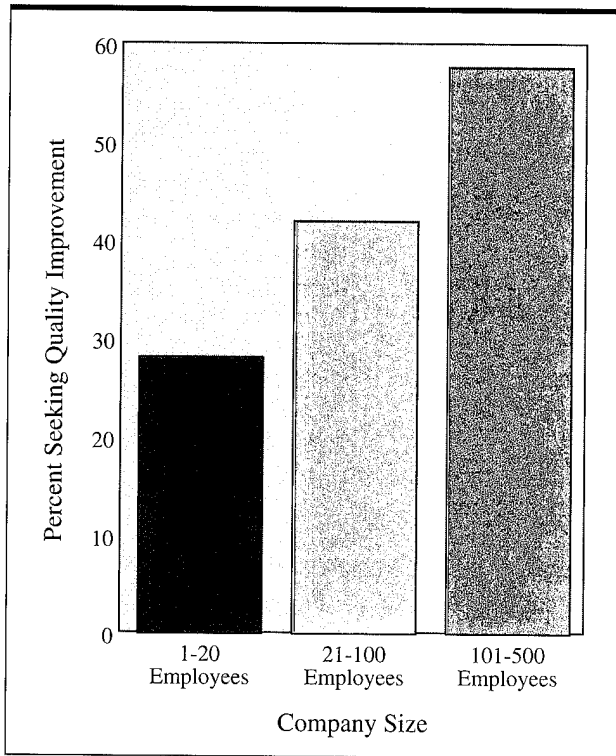

Figure 1. Meeting the Challenge—by Company Size.

The DoD began productivity improvement programs in the 1970's. An Executive Order signed by President Reagan in February 1986 mandated the improvement of productivity, quality, and timeliness of government products and services across the federal government. The Malcolm Baldrige National Quality Award was established by the federal government in 1987 to honor private companies that excel in quality achievements. The Federal Quality Institute was established in 1988 to train and advise federal managers in Total Quality Management (TQM) matters. The President's Award for Quality was initiated in 1989 to honor those federal agencies that best exemplified quality and productivity cultures. The federal government is becoming more and more conscious of quality in what it does and in what it buys.

Those firms doing business or attempting to achieve business relations with the Department of Defense are finding a buyer more and more concerned with quality. The DoD since the mid-1980's has become committed to the Total Quality philosophy. Many parts of the DoD have begun to focus on supplier quality over supplier cost. Whether or not small businesses are interested in pursuing sales of products or services to the DoD, quality aware-

ness and the pursuit of quality should prove of benefit to any company.

A more compelling reason for considering the transition to a quality culture in any small business might lie in the exorbitant cost of reworking shoddy products. The cost is not just in the direct dollars spent for the reworking process, but it is reflected in additional time expended and the stress on all the involved employees and managers. Quality improvement *will* reduce the cost of producing a product or service. It will reduce the cost of rework and the cost of fighting crises. Management's time in many companies today is dominated by efforts to fight crises brought on by inferior or inadequate **processes** and outputs. Figure 2 illustrates the changed focus that is possible through a **transformation** to a quality-driven

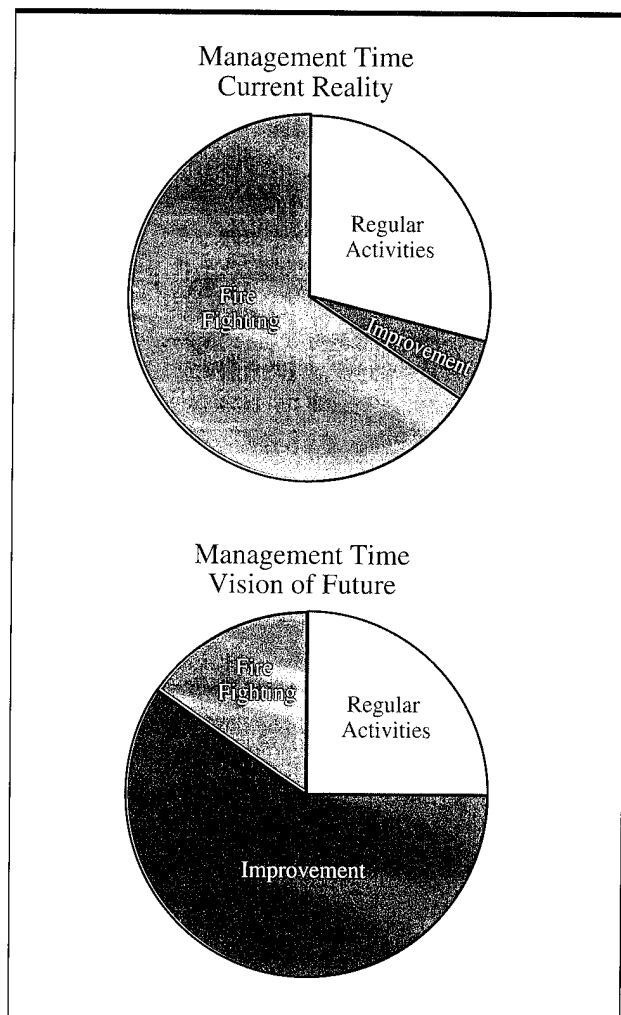

Figure 2. The Changing Focus.

organization. Note the change of emphasis from constantly dealing with crises to increased time for improvement and innovation.

What, then, is quality? It can be the speed in which a service is delivered. It can be consistency. It can be innovation. It can be reflected in low maintenance or favorable repair history. Quality can be many things. Dr. W. Edwards Deming tells us "a product or service possesses quality if it helps somebody and enjoys a good and sustainable market."⁵ Webster's dictionary defines quality as "a degree of excellence and "superiority in kind." First and foremost with quality, however, the product or service meets or exceeds the expectations of the customer. The challenge of quality, therefore, is to supply something your customers want or need, or you think they will purchase, that not only meets or exceeds their expectations but that can be produced or provided at an acceptable cost. The supplier needs to decide what to supply and what the right level of quality for that product or service should be.

Once designed and created at the quality level desired, the key to maintaining or improving the quality of the product or service lies in the continual improvement of the **processes**. Each **process** takes input, adds value to it, and then produces a product. This is the **value-added** imperative. The means by which that **process** adds value and the extent to which value is added are major determinants of the quality of the output. A **process** that adds no value should either be deleted or corrected to ensure that value is added. Figure 3 shows the producer/customer relationships related to **value-added** outputs.

Dr. Deming estimated that 95% or more of the causes for shoddy products and services can be traced to the management of **processes** or **subsystems** that create the output. The need, then, is clearly for management to improve those **processes** and **subsystems** and to monitor them continually for improvement opportunities. The responsibility for ensuring the improvement of the **processes** and **subsystems** in an organization lies with top management.

In the private sector as well as in the federal government, this commitment to quality is referred to as TQM or TQL (Total Quality Leadership). The health care industry refers to it as Continuous Quality Improvement (CQI). While the names differ, the core philosophy, methodologies, tools, and techniques are much the same. The basic concepts of the quality philosophy include:

- Careful short-range and long-range planning;
- The continual improvement of products and services and the **processes** that produce them;
- Top management commitment, understanding, and participation;
- Focus on customer/supplier relationships;
- Employee involvement in the decision-making process;
- Team approach to product or service improvement; and
- Use of statistical tools and structured techniques.

A successful quality culture balances a reliance on science and philosophy to improve and innovate all work **processes** with an understanding of and appreciation for the special knowledge, skills, and attitudes workers contribute. The basic method for achieving a quality **transformation** will probably not change drastically, but the means to achieve it will differ depending on the individual needs of each company.

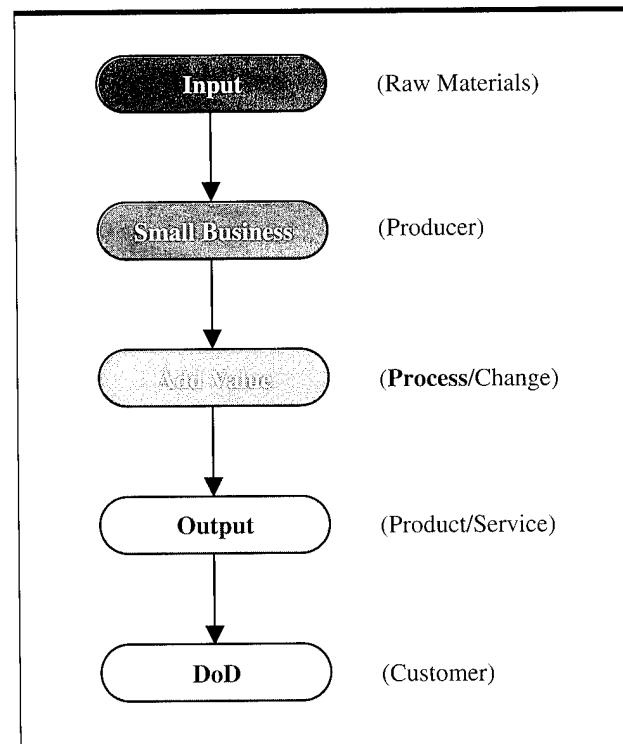

Figure 3. Producer/Customer Relationships.

The purpose of this book is to present small business management with the basic philosophy of management as envisioned by Dr. W. Edwards Deming, a pioneer and leading management visionary. It also includes some of the methods, tools, and techniques that have proven to be effective in helping to realize the **transformation** to a quality culture. A major step for small business managers is to gain an understanding of what Dr. Deming calls **Profound Knowledge**, a necessary awareness for enabling a **transformation** to a quality-centered organization.

Chapter 2, “The Deming Philosophy,” describes the basic theories that support his teachings. This section includes a discussion of the Fourteen Points, Deadly Diseases, Obstacles and the theories of Systems, Variation, Knowledge, and Psychology.

Chapter 3 is titled “Planning.” Its purpose is to describe how to get a rapid start on the quality **transformation** by systematic planning. The lack of planning is often the major weakness in the operation of small businesses. Included in this section is a description of the Plan, Do, Study, Act (PDSA) cycle developed by Deming.

Chapter 4, “Teamwork,” explores this most vital element for expanding the effectiveness of your organization. What kinds of people should serve on an action team? How should they interact? What power should they have? How can they be most effective?

Chapter 5, “Teams and Meetings,” provides advice on conducting effective meetings and includes a description of the structured approach to problem solving and continual improvement. How do you conduct yourselves in meetings? How long should meetings last? How many should serve on the team?

Chapter 6, “**Continual Process Improvement**,” includes a discussion on variation and the importance of understanding the difference between random, or **common cause**, variation and **special cause** variation. This section describes some of the statistical tools that can be used to reduce cost and increase quality.

Chapter 7, “Strategies,” contains a suggested series of steps to take to assist your company in moving toward a quality-centered culture. Where do you begin? Who should be responsible? How long will it take? What are the pitfalls?

The appendices include: A—a glossary of selected terms (**note**: all terms listed in the glossary are printed in bold

in the text); B—suggested further reading on quality management; C—detailed **PDSA** steps that can be used in problem solving or **process** improvement; D—control chart tests other than limits, and E—the bibliography. Endnote citations are listed just after the end of the main text.

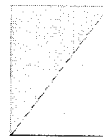

BACKGROUND

Most business people today in the United States are aware of the enormous turnaround of the Japanese economy from the 1950's to the 1970's and beyond. Once considered producers of cheap junk, Japanese products have become synonymous with quality. This incredible reversal of product characteristics was not accomplished by miracle or gimmick. It was based in the fundamentals of the philosophy of quality management that was taught to the business leaders of Japan by Dr. W. Edwards Deming. The methods he taught the Japanese led their industry to emphasize quality and the continual pursuit of improvement. Industry leaders in Japan today honor the philosopher by conferring annual Deming Awards on those companies best exemplifying his quality principles.

Immediately following World War II, the only economy capable of producing goods was the American economy. Asian and European economies had, for the most part, been brought to a halt by the destruction of war. Without competition, the United States quickly became the producer of goods for the free world. Moving from war machinery production to goods producer for world-wide consumers was a relatively easy conversion for our factories. The emphasis was on mass production in order to satisfy the demand. Quality was second, if that high, in the pecking order. The focus was on high-volume output that met minimal standards. Quickly getting out the product and selling it with the highest immediate return was the method of business operation in this country.

Then came the 1970's and the rapid rise of the Japanese economy. Japan's electronics industry had made strong inroads on the American market place in the 1960's, and, with the fuel crisis in this country early in the 1970's, the fuel efficient, reliable Japanese automobiles followed suit.

We all know the results and the adverse impact on the balance of trade and on our domestic economy. The Japanese manufacturers with their focus on customer satisfaction and long-term reliability rapidly gained market share throughout the world and, rather dramatically, in America. The resulting imbalance is strikingly detailed in one of the Federal Quality Institute's TQM booklets:

- Since 1960, the United States has lost 40 percent of its market share to foreign competitors; during the same period, Japan has increased the size of its foreign market by 500 percent.
- The nine largest banks in the world are now Japanese.
- The United States used to make 90 percent of the color TV's in the world. Now we make 5 percent.
- There are no American-made VCRs, compact disc players, or single-lens reflex cameras.⁶

Japan's economic revitalization is clearly a modern day success story that is unparalleled in history. Factors other than Deming's philosophy of quality management might also have contributed to this astonishing turnaround, but the base for this transformation was clearly founded in his philosophy. Our country, like others, was a sitting duck with our emphasis on short-term results. The uniqueness of the Japanese society and their ability to band together to carry out the long-term aims of the quality philosophy had no small hand in their success.

Deming reached his 93rd birthday in October 1993 still practicing his quality management consulting business. He died two months later in December 1993. Prior to his roughly 40 years working as a consultant, he worked at the U.S. Department of Agriculture and at Western Electric. From this experience and his association with Dr. Walter Shewhart, Deming learned the importance of the control chart in determining **special cause** variation. He also began to develop his concepts on structured process improvement from Shewhart, which later became the **PDSA** cycle. His years as a civil servant with the Census Bureau in Washington, DC provided an impetus that eventually found him being called to postwar Japan to assist with the census in that country. It was during the late 1940's and early 1950's that Deming began to teach Japa-

nese business leaders his philosophy of quality management. In meetings with the Union of Japanese Science and Engineering (JUSE), Deming taught the theory that higher quality and lower operating costs were not necessarily separate pursuits—a heretical concept in those days. The Japanese listened. They all had one clear aim in mind, rebuilding the shattered economy of Japan. The result is history. In recognition of Deming's contributions, JUSE instituted the Deming Prize, an annual award for product quality and dependability. In 1960, Deming was awarded the Second Order Medal of the Sacred Treasure by the emperor of Japan.

Deming's work and his success in Japan were largely overlooked in the United States for 30 years. Then, in 1980, an NBC White Paper, "If Japan Can, Why Can't We?" introduced quality management theories and techniques and Dr. Deming to America. In 1987, President Reagan awarded Deming the National Medal of Technology.

Many theorists and methodologists in this country and in Japan have made their mark on the rising tide of quality management concepts. Like Deming, Dr. Joseph Juran emphasized the need for management involvement in quality improvement. Dr. Armand Feigenbaum believed the quest for quality should be pursued in all departments of the organization, not just the manufacturing division. He talked about the "hidden plant," that percentage of an organization's production capacity devoted strictly to waste and rework. Dr. Kaoru Ishikawa has written extensively about quality control, and he led the highly popular "Quality Circle" movement in Japan. Dr. Genichi Taguchi is best known for his "Taguchi Loss Function," which puts forth the theory that economic loss occurs whenever there is any variation from the optimal point of a process or product. Thus, just being able to control a process or its output within a range of specified limits does not avoid economic loss. Many excellent lecturers currently conduct seminars around the country helping define and explain the various parts of Deming's philosophy. William Scherkenbach, who worked both at Ford and at General Motors, has assisted Deming for more than 20 years. Ed Baker, John Dowd, Heero Hacquebord, Brian Joiner, Gipsey Ranney, and Peter Scholtes are just a few of the many assisting in the effort to get American companies moving toward a quality-centered culture.

Thirty-two states have quality award programs.⁷ States with quality awards in 1993 are listed in Table 1.

Alabama	Missouri
Arizona	Nevada
California	New Hampshire
Connecticut	New Jersey
Delaware	New Mexico
Florida	New York
Georgia	North Carolina
Idaho	Ohio
Indiana	Pennsylvania
Iowa	Rhode Island
Kansas	South Carolina
Maine	Tennessee
Maryland	Texas
Massachusetts	Utah
Minnesota	Virginia
Mississippi	Wyoming
Colorado, Illinois, Michigan, and Montana are considering the establishment of state quality awards.	

Table 1. States with Quality Awards in 1993.

ISO 9000

International attention has been drawn to quality improvement. The ISO 9000 is a series of quality standards that outline the requirements for quality management systems. It is becoming *the* quality standard in Europe and is gaining acceptance in Canada and the United States. Established standards for measuring quality have been around since the industrial revolution began. Today, there are over 76,000 U.S. military standards, more than 12,000 U.S. federal standards, and more than 35,000 U.S. industry standards developed by 432 private sector organizations.⁸

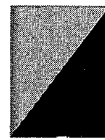

CURRENT REALITY

The Small Business Administration (SBA) estimates that 75 percent of all new businesses in the U.S. fail within the first few years of existence. Legislative efforts over the past few decades to assist small businesses have had mixed results. One of the primary reasons for the anti-trust laws passed by congress was to protect small businesses from the perceived competitive advantage held by large businesses. When the SBA was established in 1953, it was a major effort by the federal government to assist small businesses. Yet, small businesses are clearly high-risk, high-failure ventures. In poor to weak economic times, such as the early 1990's are, the small business venture is even more high-risk. But, as we have seen earlier, the percentage of small businesses embracing the quality management philosophy is relatively low when compared to larger businesses.

In many ways, the small business is a more ideal unit than the large organization for the quality management philosophy to function effectively. There are normally fewer internal cliques in small companies, and, therefore, there is less fighting and bickering between work units. The potential for effective teamwork is better in a small organization. There are fewer layers of management in most small businesses, so that the potential exists for good communications and dynamic work habits. The normally overworked small business owner and manager can often benefit the most by relying more on the skills, knowledge and attitudes of the employees who operate the processes.

On the other hand, the small business usually lacks the funds and the time to make the investment necessary to transform to a quality-centered company. Yet, that investment is very important and very worthwhile. The cost incurred by reworking or replacing the products of unpredictable, unreliable **processes**, the lost business caused by the production of poor products or services, the cost of hiring new employees caused by constant turnover are just some of the good reasons every small business should pursue the establishment of a quality culture in the workplace.

It is good to assess your reasons for changing to a quality culture. List below the reasons you and your senior staff can think of for making this transformation.

Your List of Reasons to Pursue a Quality Culture

- 1.
- 2.
- 3.
- 4.
- 5.
- 6.
- 7.
- 8.
- 9.
- 10.

The need for this **transformation** in most small businesses today is probably urgent. But, it is very important that the approach taken be a sound, comprehensive, well-planned initiative.

There are many quality methodologies and formulas for success available. Most of these will show some positive results in application. But, it is important to understand that the transition to a real quality culture is usually a long-term commitment. It will not succeed if *there is theory without action or action without theory*. In other words, it will not do just to talk about quality while not actively pursuing it. Nor will it be sufficient to establish quality action groups without a set of concepts to guide the activity. It is not a program. It is a change in the way you do business, a change in the way you look at **processes**, and a change in the way you think about the "company."

It is our recommendation that a proven philosophy, theory, and methodology be followed consistently and persistently. The Deming philosophy has a clear record of success over the past 40 years, not only in Japan but also here in this country. It is, therefore, the thesis of this guidebook to follow Deming's concepts in the pursuit of the quality **transformation**. As you begin to understand the Deming philosophy, read the works of some of the other quality experts like those listed in Appendix B. Obtain training and facilitation services that are attuned to the Deming philosophy. Then proceed by following Dr. Deming's advice, "Just do it!"

CHAPTER 2

THE DEMING PHILOSOPHY

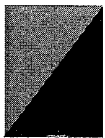

THE MAN AND HIS LEGACY

Dr. Deming's 70 years of developing and teaching concepts and techniques to improve the organizational system have had an enormous impact on quality management theory. The practice of his theories and philosophy have dramatically improved the quality and performance of companies in Japan and other countries. Businessmen the world over use his theories and techniques and are living proof of the success that is possible through the effective use of his system and his philosophy. As early as 1950, Deming promoted the revolutionary concept that quality and productivity were not mutually exclusive goals. His chain reaction, shown in Figure 4, demonstrates how higher quality actually means *lower* costs and continued survival.

The bulk of the Deming philosophy is contained in his Fourteen Points, the Deadly Diseases, the Obstacles, and **Profound Knowledge**. The latter element contains the theories of Systems, Variation, Knowledge, and Psychology. These subjects are covered in two of his books: *Out of the Crisis*¹⁰ and *The New Economics*.¹¹ In this chapter, we will describe the highlights of Deming's teachings.

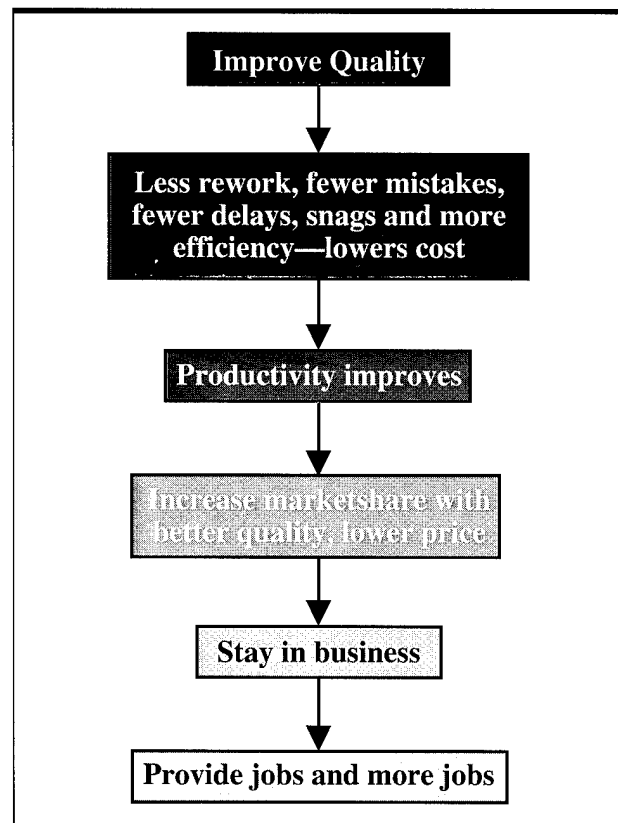
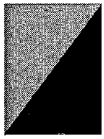

Figure 4. Deming's Chain Reaction⁹.



THE FOURTEEN POINTS¹²

Many of the fourteen points are interrelated. These points can be viewed as the guidelines for beginning to change the way you conduct business and the way you think about your company. The major transition needed to obtain a good understanding of these points is the change of focus from thinking solely profit to thinking mainly quality.

1. Create **constancy of purpose** toward improvement of product and service, with the aim to become competitive and to stay in business and to provide jobs.
2. Adopt the new philosophy. We are in a new economic age. Western management must awaken to the challenge, must learn their responsibilities, and take on leadership for change.
3. Cease dependence on inspection to achieve quality. Eliminate the need for inspection on a mass basis by building quality into the product in the first place.
4. End the practice of awarding business on the basis of price tag alone. Instead, minimize total cost. Move toward a single supplier for any one item, on a long-term relationship of loyalty and trust.
5. Improve constantly and forever the system of production and service, to improve quality and productivity, and thus constantly decrease costs.
6. Institute training on the job.
7. Institute leadership (see point 12). The aim of leadership should be to help people and machines and gadgets to do a better job. Leadership of management is in need of overhaul, as well as leadership of production workers.
8. Drive out fear so that everyone may work effectively for the organization.
9. Break down barriers between departments. People in research, design, sales, and production must work as a team, to foresee problems of production and in use that may be encountered with the product or service.
10. Eliminate slogans, exhortations, and targets for the work force asking for zero defects and new levels of productivity.
 - 11a. Eliminate numerical goals for the work force and numerical goals for management.
 - 11b. Eliminate management by objective. Eliminate management by numbers, numerical goals. Substitute leadership.
 - 12a. Remove barriers that rob the hourly worker of his right to pride of workmanship. The responsibility of supervisors must be changed from sheer numbers to quality.
 - 12b. Remove barriers that rob people in management and in engineering of their right to pride of workmanship. This means, inter alia, abolishment of the annual or merit rating and of management by objective, management by the numbers.
13. Institute a vigorous program of education and self-improvement for everyone.
14. Put everybody in the company to work to accomplish the **transformation**. The **transformation** is everybody's job.

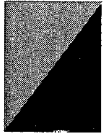

THE DEADLY DISEASES¹³

Dr. Deming described what he called the Deadly Diseases. They represent some perceived shortcomings that can erode any quality movement. Like any serious disease they are difficult to cure, and, if you are not alert, they may seriously affect the health of your organization.

1. Lack of **constancy of purpose** to plan product and service that will have a market and keep the company in business and provide jobs.
2. Emphasis on short-term profits: short-term thinking (just the opposite from constancy of purpose to stay in business), fed by fear of friendly takeover, and by push by bankers and owners for dividends.
3. Evaluation of performance, merit rating, or annual review.
4. Mobility of management; job hopping.
5. Management by use only of visible figures, with little or no consideration of figures that are unknown or unknowable.
6. Excessive medical costs.
7. Excessive costs of liability, swelled by lawyers that work on contingency fees.

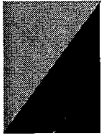

THE OBSTACLES

(The Obstacles are the pitfalls or roadblocks that often interfere with an organization's movement toward and realization of a quality culture. Not all organizations or leaders have these obstacles to surmount, but they are the common roadblocks.)

1. "Hope for instant pudding"¹⁴—The **transformation** takes time and takes effort. There is no quick path to quality.
2. "The supposition that solving problems, automation, gadgets, and new machinery will transform industry."¹⁵
3. "Search for examples"¹⁶—Attempting to transform to a quality culture by copying other company's procedures is likely to fail. Improvement of quality is a theory that can be transferred to any company, but only the theory can be transferred.
4. "Our problems are different."¹⁷—Everyone's problems are different, but the principles for improvement are universal.
5. "Obsolescence in schools"¹⁸—Business schools teach how to make a short-term profit rather than how to produce quality.
6. "Poor teaching of statistical methods in industry"¹⁹—Don't use poorly trained people to teach statistical methods to your employees. Hire competent statisticians who are leaders of **Profound Knowledge**.
7. "Use of Military Standard 105D and other tables for acceptance"²⁰—Using such standards to accept or reject products or services guarantees defects. **Continual Process Improvement** will help to ensure quality.
8. "Our quality control department takes care of all our problems of quality"²¹—In this kind of company the wrong people are responsible for quality. Quality is the responsibility of the process operators and especially of management and the board of directors.
9. "Our troubles lie entirely in the work force"²²—The workers are handicapped by the system, and the system is the responsibility of management.
10. "False starts"²³—The use of "pieces" of the quality philosophy, methodology, tools, and techniques can provide deceiving results. Remember, there is no instant pudding. The **transformation** takes time and effort.
11. "We installed quality control."²⁴—It cannot be installed. The improvement of quality requires a learning process, over time, led by management.
12. "The unmanned computer"²⁵—The computer is just a machine. It can collect and summarize data, but it cannot discern what kind of variation exists in a process. An understanding of variation is vital to improving quality.
13. "The supposition that it is only necessary to meet specifications"²⁶—Specifications do not determine quality. Quality is evidenced by something that meets or exceeds the customers' expectations.
14. "The fallacy of zero defects"²⁷—No process is without variation. The point is to continually reduce variation, but it is not to seek the impossible. To seek results within specification limits expecting zero defects is an illusion. There is still loss, because there is always variation.
15. "Inadequate testing of prototypes"²⁸—A prototype is just one instance of a product or service. It takes many instances and continual improvement of the process to approach quality.
16. "Anyone that comes to try to help us must understand all about our business"²⁹—Those who come to help you must understand how to improve **systems**. Together with those who understand the **systems**, they can enable **continual process improvement** of the **systems**.³⁰

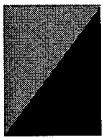

PROFOUND KNOWLEDGE

Profound Knowledge to Deming is comprised of four theories: Systems, Variation, Knowledge, and Psychology. Deming says managers do not need to become experts in these areas to be able to understand and apply them. But, he does call upon managers to develop a deep appreciation for the overall organizational **System**, to understand something about *Variation*, to grasp a theory of *Knowledge*, and to appreciate human *Psychology*. Basically, Deming's theories can be described as follows:

1. The Theory of **Systems** requires that management understand the organization as a whole **system**, a complete picture; and they must emphasize the **optimization** of that **system**. It is essential that the **aim** of the system is communicated to and understood by all members of the organization. Moreover, the best chances of achieving that **aim** come when all the parts of the **system** are working *collectively* toward the **aim**. In this regard, it is wrong for one unit of an organization to excel to the point where it adversely affects the contributions of other units to the **aim** of the company. Teamwork is required across the organization. Management must concentrate on seeing the forest as well as seeing the individual trees.

The nourishing of one or two of the trees to the detriment of the others, however, is a major mistake by management. Leadership must lead the **optimization** of the **system**. This is best accomplished by focusing on the **aim** of the company.

This theory requires a sharply different focus on your organization. Figure 5 illustrates the **systems** view as envisioned by Deming. This is in stark contrast to the standard hierarchical view depicted in the usual organization charts. The **systems** view focuses on pleasing the customers, while the organization chart focuses on pleasing the managers. The **systems** view only *implies* that management is involved, the organization chart only *implies* that customers are involved. Quality in the **systems** view is the result of the interactions of all parts of the **system**, while quality in the organization chart is the result of individual or team efforts. In the **systems** view when fault occurs, the cause is sought within the **system**. In companies governed by the organization chart when fault occurs, the cause is sought in the people.

2. The Theory of Variation involves understanding variation and knowing how to deal with it. There is variation in everything. Variation causes economic loss. The normal variation in all **processes** is called **common cause** variation. **Special cause** variation also can adversely affect a **process**. It is important

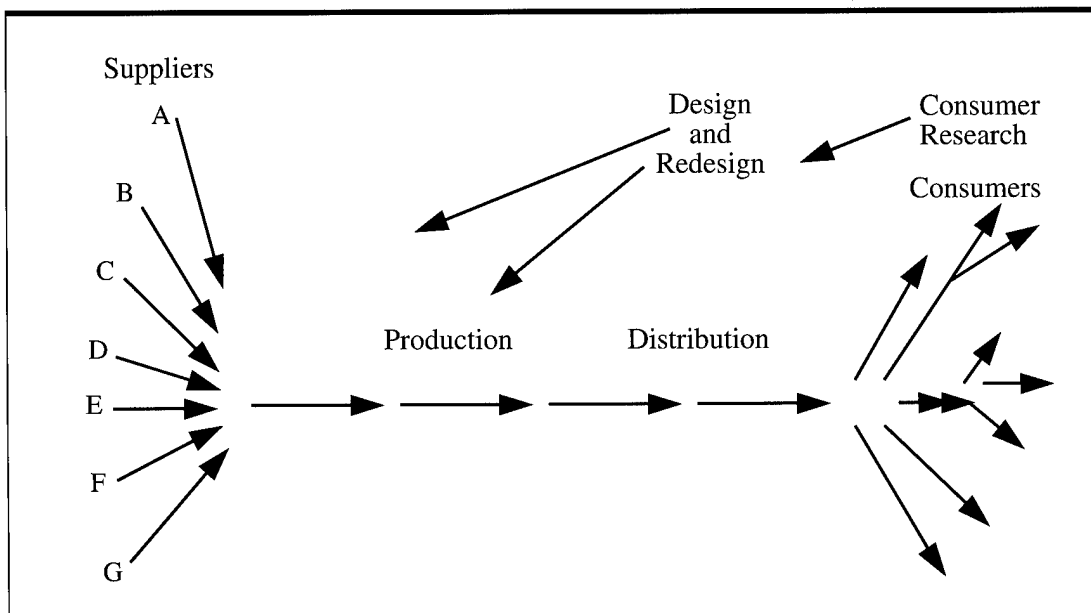

Figure 5. Deming's Systems View³¹.

to detect **special cause** variation because your approach to dealing with it should be different than the way you deal with **common cause** variation. It is often possible to detect the presence of **special cause** variation by observing data patterns. There are some simple statistical tests to help determine whether **special causes** exist. **Special cause** variation can occur when a cause outside the **process** affects the **process**. It can also occur within the process and is usually specific to a person or group. Deming identifies two kinds of mistakes arising from confusion of **special causes** and **common causes**: mistake the cause of a variation in a process as **special** when it is actually **common cause**; mistake the cause of a variation in a process as **common** when it is actually **special cause**.

3. The Theory of Knowledge is the most abstract, and in many ways the most important, of the four tenets of **Profound Knowledge**. In it Deming asserts that management is prediction. Everything you do as a manager involves predictions of one kind or another. In order to predict, you must test a theory over time. As you observe theory being tested by everyday occurrences, you obtain knowledge about what works and what does not work. With these data you can modify your theory. One exception to a theory calls into question the usefulness of that theory. The **PDSA** cycle is the method to use to analyze your **system**. The resultant predictions allow you to plan. Planning is the first step in **continual process improvement**.
4. The Theory of Psychology requires understanding the variation in everyone: leaders, employees, suppliers and customers. You must learn the skills, knowledge, and attitudes of others in order to be able to **optimize** the **system**. You need to understand that almost everyone has an innate desire to do a good job. The manager's responsibility is to encourage and enable that attribute so that all employees can improve. People are different from one another. Yet, some managers treat employees as though they should all be the same by ranking each of them against one another. Ranking is destructive. Leaders need to understand and nurture the intrinsic (innate) motivational forces that people have. They also need to apply extrinsic (external) motivational forces that produce positive results in people. Examples are fair pay, good work environment, good equipment, etc. Ranking and fear can destroy the positive intrinsic attributes in a person. Deming described the lifelong impact of what he called the "Forces of Destruction," depicted in Figure 6, to indicate the need for management to restore the intrinsic motivation, self-esteem, dignity, cooperation, curiosity, and joy of learning to all individuals working for them.

This is a synopsis of the Deming philosophy and its theories. Some might say this is all just common sense. If this is so, then why is it not in common practice? Common sense, in fact, is what has taught us to rate, rank, and grade people thereby destroying them as shown in Figure 6. Common sense, one might contend, is probably the source of the deadly diseases.

Moreover, there is considerable depth, particularly in the **Profound Knowledge** concepts, to warrant careful study and consideration of Deming's teachings. It is his thesis that you need not be an expert in his theories to make the **system** work. But you must be continually seeking improvement, continually learning more about the usefulness of his theories. It is not by chance that the first of the 14 Points is **constancy of purpose**.

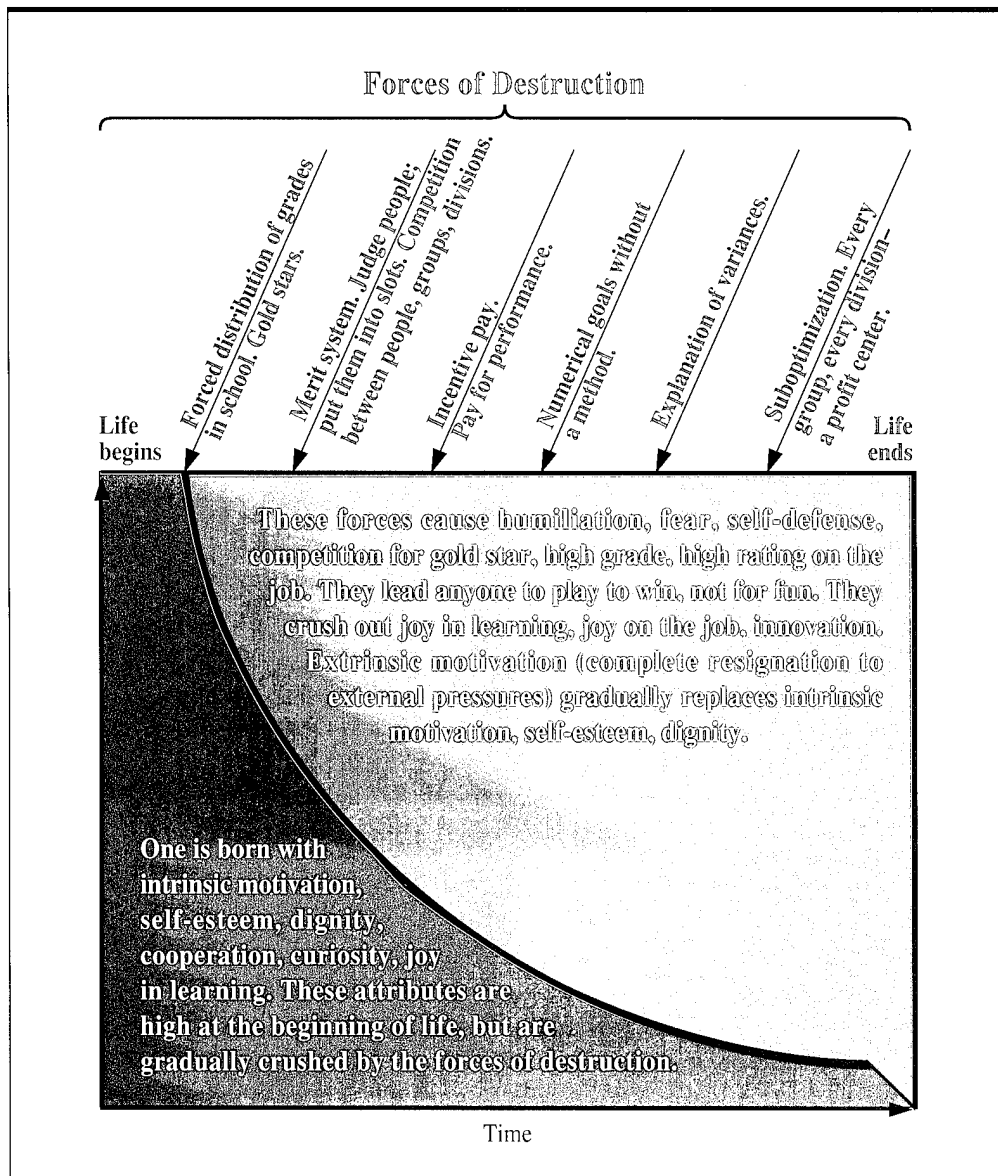
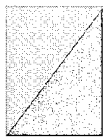

Figure 6. Forces of Destruction. "The forces along the top rob people, and the nation, of innovation.... We must replace these forces with management that will restore the power of the individual."³²

CHAPTER 3

PLANNING



PDSA CYCLE

Your transition to a quality culture begins with the **PDSA** cycle: *Plan, Do, Study, Act* (See Figure 7). This cycle should be ever present in your company's activities. No more shooting from the hip or reacting to crises without working through the **PDSA** cycle. Plan before doing; and, when you do something, do it on a small scale over time with customers. Then study the results of that experiment before making a final commitment. Make a habit of using the **PDSA** cycle as your way of doing business.

One major use of the **PDSA** cycle is with strategic planning. A carefully prepared 5-year or 10-year strategic plan is the most typical. This plan should be centered around an **aim**, or vision, statement. The plan includes the values, or guiding principles, of the organization; the mission, or reason for existence, of the company; and the objectives, or short-term steps, needed to begin the realization of the **aim**. Nothing will be more important than your clarification of the **aim** or vision, of your organization.

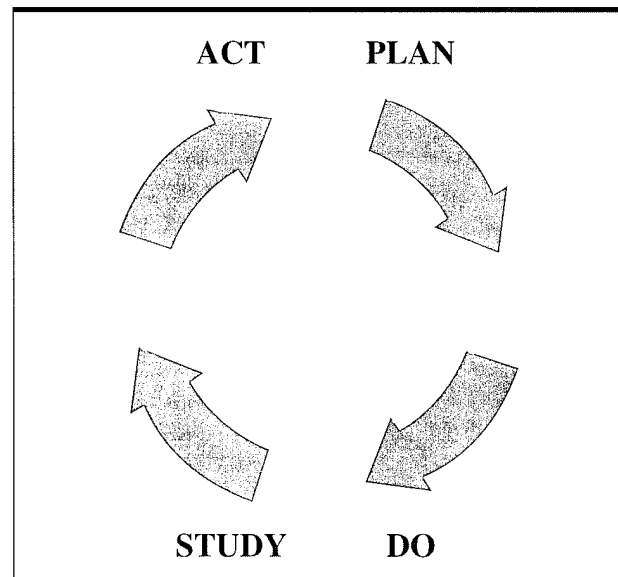
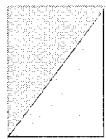

Figure 7. The **PDSA** Cycle.

The **aim** statement should be a constant byword throughout your company. The strategic planning cycle aligned with the **PDSA** cycle is illustrated in Figure 8.

Aim and mission statements are not just slogans. They are the vital statements that identify your organization. Their importance to your company and its employees is no less than the Bill of Rights and the Constitution are to the American people. It takes time to create **aim** and mission statements. The time will be well spent.



AIM

A good **aim** statement is your dream for your organization. The **aim** reflects your **constancy of purpose**. It must stand the test of time and should be value-oriented. Dr. Deming stated that "...the **aim** never be defined in terms of activity or methods. It must always relate directly to how life is better for everyone."³³ It is the overriding

vision of your company. It might answer the question: What do you want your company to be in 5 or 10 years?

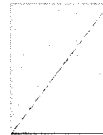

VALUES AND GUIDING PRINCIPLES

These are vital elements in developing and maintaining a quality-driven organization. A good source for guidance is the 14 points presented by Dr. Deming (see page 10). Understanding and adapting these principles to your organization will be of great benefit in guiding your company to a quality culture and maintaining these gains once achieved. However, many other principles can be tailored to your organization to support your way of doing business. Other values that might be used are concerned with ethics, responsiveness, and timeliness. Each company must determine what its own values and guiding principles are in accord with its value system and vital concerns.

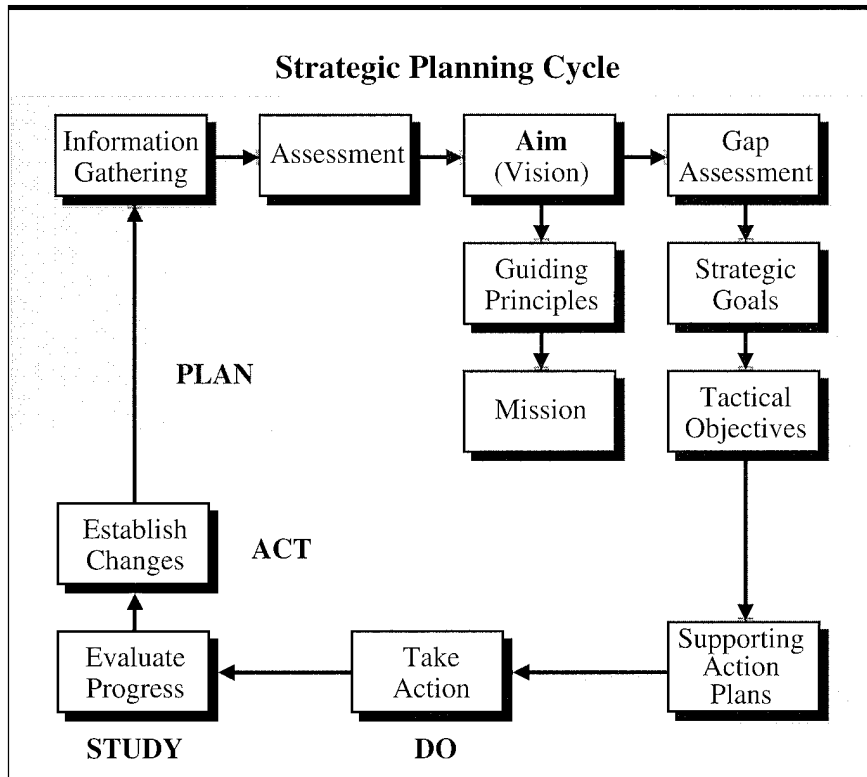
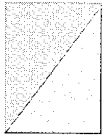

Figure 8. The Strategic Planning Cycle.



MISSION

A good mission statement will contain a message conveying the following type information:

- Why you are in business
- Who your customers are
- What your most cherished values are

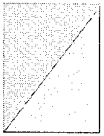

OBJECTIVES

The statements of objectives are task statements, the means by which your company intends to achieve its **aim**. One approach is to designate goals that are achievable in 1 or 2 years that will direct your company toward its **aim**. Other objectives might be longer term such as 3 to 5 years. These objectives can be to overcome obstacles or roadblocks to the **aim**. They might also be steps to improve strengths in the organization. Objectives are the means by which your company intends to achieve its **aim**. They are specific steps to be taken in a particular time frame. The people responsible for each objective are to be specified. The action item for each objective should include:

- Title of the objective and its goal
- Description of the task or tasks to be used to reach the goal
- Timetable for completion
- Responsible party or parties

The key elements, then, of long-range planning are to develop an **aim** statement, a mission statement, and the organization's values. Top management then needs to analyze the gap between the **aim** and current reality and develop the strategic goals to enable the realization of the **aim**. The objectives needed to achieve those goals are then developed with detailed action plans. These elements are normally developed by senior staff and then explained to all employees. It is important that everyone

has the opportunity for input to the strategic plan. The value of having everyone "buy off" on the strategic plan cannot be overestimated. All employees must be made to feel like part of the team from the very beginning of this process, and, as new employees are added to the company, from the very beginning of their employment with your firm.

Once the strategic *Plan* is drafted, the next step is to *Do*, often best accomplished with a pilot program to test the validity of the planned activities on a small scale, low-risk basis. Once the pilot program has been conducted, a careful *Study* should be made of the success of that program. If adjustments are necessary, they can be made at this time and then be *Studied* to evaluate the success. Any changes are then institutionalized in the *Act* step. The cycle brings us around to the beginning where we review the process, *Studying* the then current situation and *Planning* improvements. The **PDSA** cycle is never-ending, providing continual improvement of the various **processes** and **subsystems** operating in the organization.

It is recommended that the strategic planning process be initiated before the budget cycle so that its results can be incorporated into the budget. The strategic plan should be reviewed on a regular basis. A 6- or 12-month review period is typical. Each review should assess the organization's progress toward a quality culture including a review of the objectives, mission validation, and overall progress toward the organization's **aim**. Each review is a repetition of the **PDSA** cycle.

The **PDSA** cycle is the major tool to be used in a quality culture. It is a form of the scientific method. In simple terms, it means that we plan action before we do it. This means that we first learn all there is to learn about the **process** in question. We gather data, analyze data, and study the data. Then we plan an action on a small scale to attempt to improve the **process**. We study the results of that pilot effort. The next step is to finalize or institutionalize whatever it was that appeared to work. This cycle is repeated again and again in a quality culture to seek continual improvement.

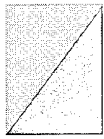

TRANSFORMATION

Top leadership must work at changing the organization to a quality culture. This **transformation** requires an emphasis on fulfilling the potential of the organization and continually improving its processes. The focus is on what your company can become rather than on where it has been; the key is on continual improvement. The **aim** of the company, its mission, the values and principles that will guide it—these are the elements to be considered to build a bridge to the future. **Transformation** begins with top leadership. Top leadership encourages and enables all to follow. This is a different view of the world. Top management must transform to the new style of leadership. Many of the old ways of doing business must be cast aside in order to achieve an effective changeover. It takes time, it takes courage, it takes financial investment, and, as Deming noted, it takes knowledge.

Recharging the Infrastructure

The **transformation** to a quality culture requires many significant changes in an organization. The roadside is littered with organizations that have attempted to transform to a quality culture without a total commitment from the senior leadership. Top management must not only be committed to quality, but they must obtain the knowledge and show the way for the rest of the company to achieve a quality culture. One of the first steps is to establish quality as the driving factor in all the company does. Senior staff meetings should become top management quality meetings. Their meetings should be quality-driven, concentrating on customer needs and satisfaction, **systems** review, continual improvement initiatives, and other quality-centered concerns.

In firms with many employees, middle management quality teams should be established. Cross-functional teams made up of middle managers should be established to provide continual review of cross-functional activities. In smaller companies where there are few if any middle managers, cross-functional teams can be composed of representatives from the various functions who interact with others in a given **process**. Ad hoc, or process action teams, can be established to review a given **process** for continual improvement or for problem solving. These ad hoc teams are often dissolved after they have accomplished their mission. Figure 9 shows one scheme for a quality-

driven organization including the main responsibilities of each type team. Keep in mind the need for a **systems** view as depicted in Figure 5.

Note the use of the **linking pin** from top management to middle management teams and from middle management teams to action teams. The purpose of the **linking pin** is to provide support from management and to facilitate communications down and up the chain of command. The **linking pin** is not a control factor but a team member with status equal to all other team members. This in no way diminishes the **linking pin's** role as a leader, but he should not automatically be considered the leader of the team.

Note also the changing emphasis as top management is responsible for the overview of the organizational **system** and each of its **subsystems**, middle management teams are responsible for **subsystems** and their component **processes**, and the action teams are responsible for individual **processes**.

It is not advisable, with the exception of cross-functional teams, to establish top management or middle management quality teams separate from the rest of the organization. The need is to ensure that the focus of standing teams is on quality and continual improvement. If cross-functional teams do not now exist, they should be established where **processes** cross functional lines and should be chartered to focus on the continual improvement of the **processes** for which they are responsible. The quality focus of all these teams conveys the important message to all employees that management is committed to quality not only in what it says but what it does.

Leadership's Roles and Responsibilities

As mentioned earlier, it is leadership's responsibility to take part in and enable the **transformation** to a quality culture. This is a double-edged sword. On the one hand, it requires that the leader know why the **transformation** is necessary. He must be firmly committed to that necessity and must lead the organization through that change. On the other hand, the leader must transform himself to the new style of leadership.

The **transformation** to a new style of leadership is perhaps the most difficult of all the changes needed to attain a quality culture. It is an individual, ego-centered changeover from, what for some might be a dictator role to a coaching role; from a close-minded order-barking role to an open-minded, counselor role.

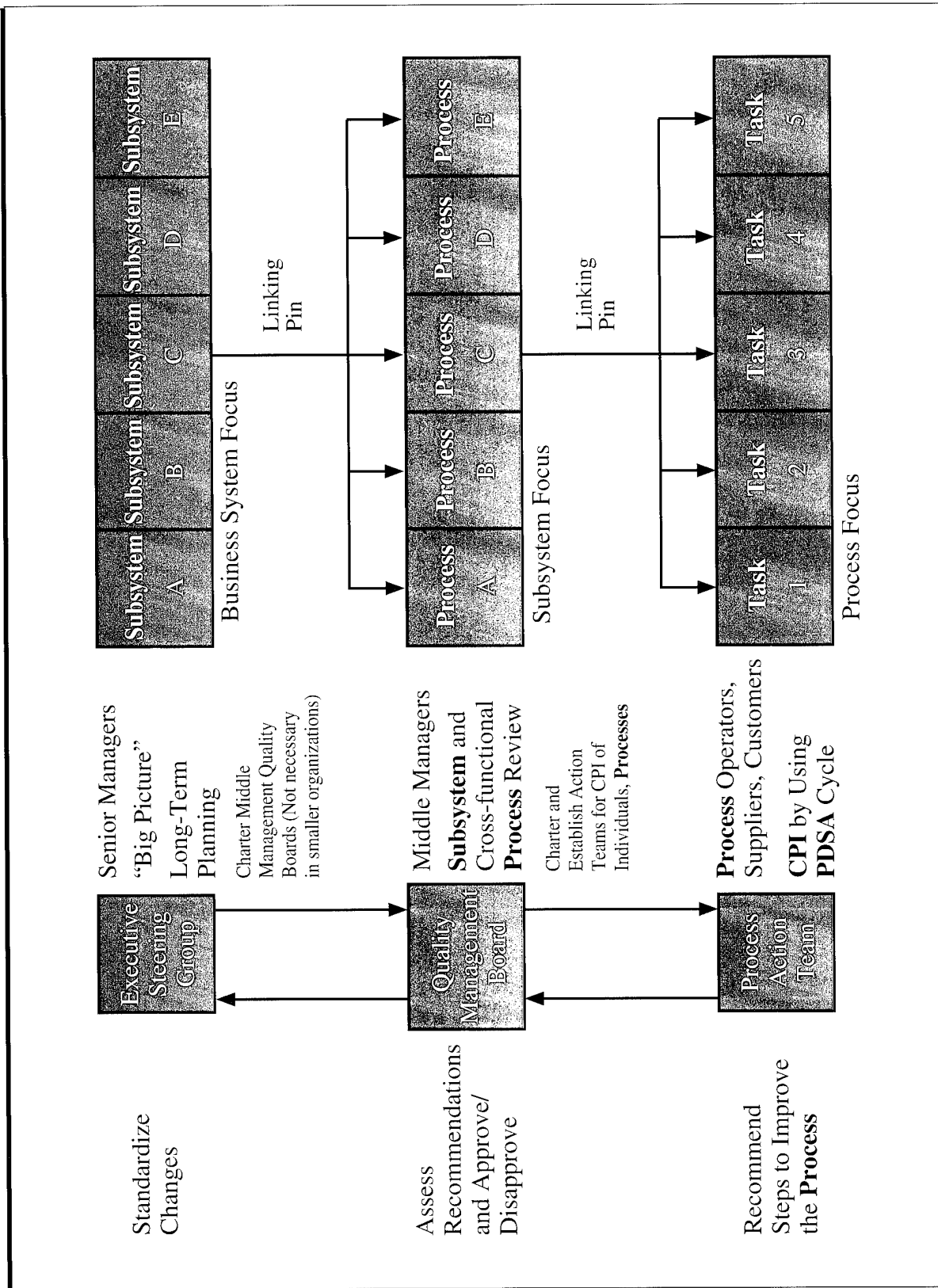

Figure 9. Typical Quality-Oriented Infrastructure.

It requires that the leader trust the employee, have faith in the employee's ability, and believe the employee wants to do a good job. It is important that leaders trust their employees and that they encourage them to take risks. The standard statement, "If you want the job done right, you have to do it yourself," must be discarded. Without trust there is no real teamwork and there is no atmosphere for innovation. In that type of **suboptimized** workplace, there is no opportunity for real growth.

The **transformation** requires that the leader provide the employee with the proper training, education, tools, and facilities to accomplish the job. It requires that the leader be willing to delegate to the employees who operate a **process** the power to make decisions for its improvement. It requires that the leader not hold back information to solidify his or her power base. In short, for some this will be a massive **transformation!**

There are many advantages awaiting the leaders who succeed with the **transformation**. The pool of experience, brain power, and enthusiasm under the leader's tutelage is a massive asset for accomplishing the day-in and day-out activities of any business. The trusted, happy employee is far less likely to cause headaches and ulcers for his leaders and for himself than is the distrusted, unhappy employee. The employee who finds joy in his work is easily joined with other committed employees into effective working teams. Everybody wins in this type organization: the employee, the leader, the organization, the customer. The result is an **optimization** of the organization.

This is not to say that the leaders in an organization are prevented from making decisions. Leadership may choose to approve or disapprove the recommended changes for improvement provided by the employees, or they may empower their employees to make those changes where they see fit.

Management must understand that a major part of their job is to predict. They must develop theories in order to predict, so they can make decisions based on those predictions. The bottom line is that the leadership, having the overview of the whole **system**, is responsible for decisions on matters related to the well-being of the organization and the pursuit of its **aim**.

The **transformation** responsibilities that fall on your shoulders, then, are as follows:

- Know and believe in the need to transform leadership and the organization.
- Change yourself to the new style of leadership.
- Be constant in your commitment to continual improvement.
- Develop a detailed plan for the **transformation**.
- Be unflagging in your support for others involved in the **transformation**.

Top management must understand that their role is to oversee the whole organization, the entire **system**. They need to be in accord with the **aim** of that **system**. They need to communicate that **aim** to all leaders and **process** operators of the organization. Their responsibility is to **optimize the system** (company) in order to steer that organization toward its **aim**. Top management is not responsible for managing the parts. That is the job of middle managers and the **process** operators directly involved with the **subsystems** and **processes**. In the optimized **system**, management and **process** operators throughout the organization must function as a team. The team understands the **aim** and strives to reach it through individual effort and cooperative teamwork.

CHAPTER 4

TEAMWORK

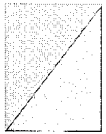

COMPETITION OR COOPERATION?

Deming urges leaders to abandon competition and to seek cooperation. He promotes this change within your organization and externally with your “competitors.” It should be clear that internal competition is harmful to the company and almost always harmful to efforts to achieve the company’s **aim**. When unit A of an organization competes against unit B of that organization, one of the units loses. The losing unit’s contribution toward the **aim** of the company is thereby lessened, and the company loses. Deming’s approach is to create a **win-win** situation whereby the company’s **aim** is achieved and none of its units “loses.” This line of reasoning goes right to the heart of the “**systems**” approach in **Profound Knowledge**. The **optimization** of the **system** is the overriding matter of importance, *not* the strengthening of one of the parts at the expense of any of the other parts in the organization.

The switch from competition to cooperation with regard to external organizations is harder for some to accept. Nonetheless, it too is an important part of the **systems** approach envisioned in **Profound Knowledge**. Deming’s point is that, rather than seek out a bigger piece of the pie by competing for it, make the pie bigger, in part, by cooperating with other companies. This results in an

increased pie slice for you as well as for the other companies. No one loses, another **win-win** situation. Deming uses a personal example of two service stations, each of which owned a tow truck. Once when he called for a tow truck, the station he called sent over the truck owned by the other station, presumably because the original station’s truck was not available. The pooling of resources increased the market for each service station without decreasing the market share of the other. The result was an increase in their market and a **win-win** for both.³⁴ This comparison is visualized in Figure 10 below.

Teamwork is integral to a quality culture. Teamwork depends on many factors. Team members need to feel equal, to feel free of fear, to experience joy in their work, to empathize with teammates, to have common objectives, to have the necessary knowledge, and to have a framework for action. Good leadership ensures that these needs are met, not only in action teams but in all facets of the company’s operation. Above all, employees need to feel empowered to improve the **processes** on which they work—in other words, to have some control over the things that dominate their daily workday activities. There are other factors that go into creating good teamwork, but the above list is critical to success.

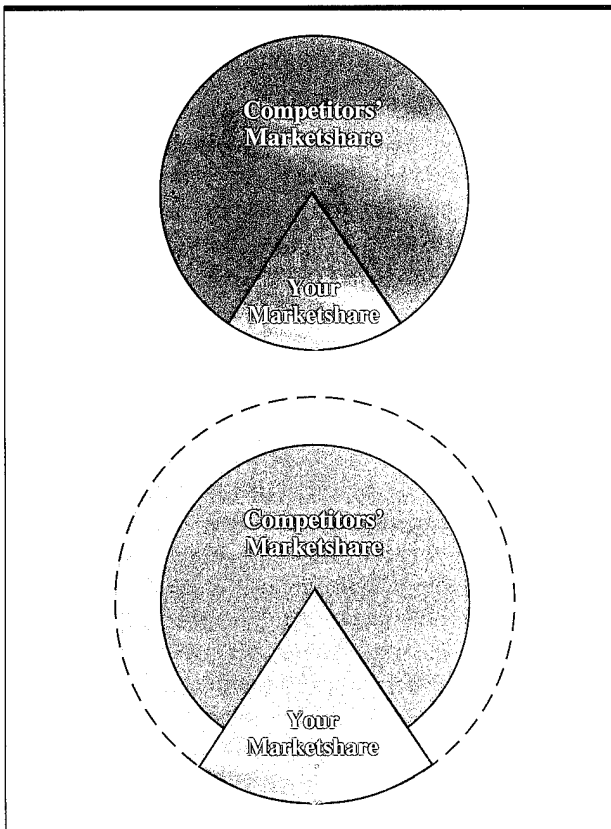
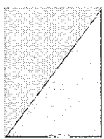

Figure 10. Increasing Your Slice of the Pie by Making the Pie Bigger.



EMPOWERMENT

Employee **empowerment** provides the employees with the power to improve the **process** on which they work, the tasks with which they are most familiar. This **empowerment** must be accompanied by an understanding of the **aim** of the organization and by leader guidance, encouragement, and support. The challenge for management is to move decision-making to the lowest appropriate level of the organization. It is recommended that the employees be given the latitude to make changes in their **processes**. Be certain, however, that the empowered employees are well prepared to assume the responsibility. They should be trained in the tools and techniques of continual improvement. The team mission and where it fits with the **aim** of the company must be communicated to them.

Using the **PDSA** cycle, establish small scope, empowered team efforts, and study their recommendations.

Management needs to respond quickly and assertively to recommendations coming from employee action teams or individual employee suggestions for improvement. It is important to realize that the employees are stakeholders in the organization, and as such, deserve to be included in the decision-making that affects their day-in and day-out activities in the workplace. Moreover, employee **empowerment** is manifest in an organization when everyone is involved in quality improvement and quality is everyone's way of doing business.

Equality

Come to the table with all team members considered equal. Everyone has an equal voice in the affairs of the team. Equality encourages the team attitude, trust, spontaneous thought, and creativity. Inequality breeds divisiveness and distrust and stifles spontaneous thought and creativity. Every member of a team needs to be made to feel like an equal and a valued member of the team. This is not to say there is a lack of respect for the rank or position of team members. Everyone is valued for their contributions to a team: leaders for their leadership ability, accountants for their ability with numbers, meat cutters for their skills, clerks for their contributions. Trust among teammates is far easier to achieve in teams where everyone feels equal. Innovation and creative thinking are enhanced where people feel free to express their ideas without regard to their position in the organization and without fear of reprisal if their ideas run counter to those of others. Freedom enables innovation and creativity.

Freedom from Fear

Freedom from fear is vital, moreover, if we are to encourage freedom of expression. Nothing will shut up someone quicker than the fear of reprisal or the fear of public embarrassment. Fear should *never* be used to "motivate" employees. Leaders must make it clear that their primary role is not to criticize and fire people but to encourage and guide them. The challenge is to avoid being judgmental. Learn to listen and expand on the ideas of others rather than hastily discarding these ideas as unworthy. Many a worthwhile idea has developed from "fly to the moon" concepts. Listen and be open to creative thinking. A crucial day-in and day-out task for leaders is to ensure that fear is removed from the workplace.

Joy in the Workplace

Fear and joy are not opposites, but fear can suppress joy. Most people have an intrinsic desire to do a good job. Everybody wants to be important. All employees need to be given the benefit of the doubt that they can do good work and that they are important. Managers who nurture this belief in their employees and who remove fear from the workplace find workers who experience joy. Workers who feel some control over their destiny in the workplace and who feel their own importance for the work they do tend to enjoy their work. Some necessary ingredients for this joy are as follows:

- Proper tools
- Good working conditions
- Good training
- Freedom from fear
- Guidance and **empowerment**
- Encouragement and praise
- Open communications
- Appropriate compensation

Appreciating Team Members

By careful listening we can better appreciate the strengths in knowledge, experience, humor, persuasiveness, logic, ability, etc. that each team member possesses. This awareness is very helpful in the development of good teamwork skills. We learn who to turn to for such matters as legal help, financial advice, details, overviews, equipment limitations, and manpower availability. The more awareness we have of our team members' capabilities the better we can function as a team.

Common Objectives

It is important that each team member knows the objectives of the team. The mission of the **process** or **subsystem** on which the team is working is always to do something or make something for someone. Whatever the team does, whether in a service industry or in a manufacturing company, it should be adding value to a product or service. This **value-added** step is the key to any objective. The team must always be aware of this focus. Again, this is the **value-added** imperative.

Knowledge

All members of the team need to possess the knowledge necessary to complete their tasks. Managers who hold back information from the members of their teams are doing themselves a disservice. Not only does this create distrust among the members, but it limits the team's ability to visualize the total picture of the **system** in which they function. For example, there is no good reason to keep from employees information related to the company's sales figures, hiring policies, future plans, and other team efforts. This kind of knowledge engenders trust and loyalty as well as providing a good perspective on the company, its **aim**, and its mission—all potentially useful information for problem solving, innovation, and creativity. Knowledge *is* power, so empower all employees with the information they need to function as first-rate citizens in their company.

CHAPTER 5

TEAMS AND MEETINGS



FRAMEWORK FOR ACTION

When involving employees in **continual process improvement** or in problem-solving action teams, do it in an organized manner. The **PDSA** cycle is a good, simple and structured approach. Figure 11 shows the highlights of a typical **process** improvement cycle.

Additional suggested details of the above procedure are included in Appendix C. This framework provides guidance that helps to avoid tampering with a **process** and introducing harmful or unnecessary changes. When used with action team **continual process improvement** meetings, it ensures all team members understand the **process**, what drives it, who contributes to it, what everyone's needs and concerns are, and what the customer wants. By going through the steps in order, the structured **process** analysis approach saves time wasted in bouncing back and forth between analysis and solution stages, which usually results in a disorganized meeting, wasted time, and the necessity for the group leader to push the group toward solutions just to get the job done.

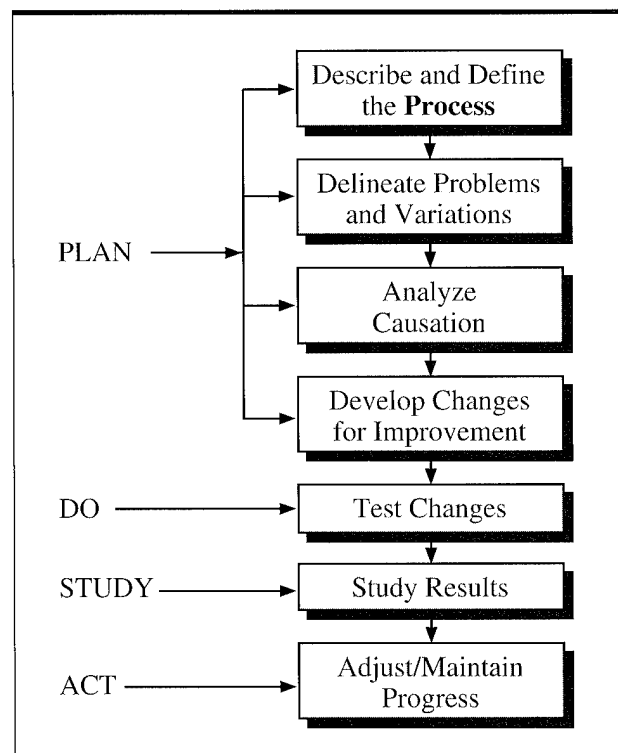
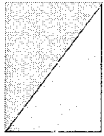

Figure 11. PDSA Cycle and Process Improvement.



MEETING MANAGEMENT

Agendas and Facilitators

An agenda should be prepared prior to every meeting and distributed well in advance of the session. This is particularly important if advanced preparation is required of the membership. The chairman normally prepares the agenda. However, a facilitator often assists in its preparation. It is advisable to use a professional facilitator in early meetings until the team becomes adept at self-facilitating. This will add to the cost of conducting meetings but should be more than offset by the time saved and the valuable guidance a facilitator will provide. The facilitator focuses on the conduct of the meeting rather than the content. The facilitator ensures the focus is maintained and the appropriate team-building techniques are employed. The facilitator also serves as quality advisor to the team.

Team Size

It is usually best to establish teams with between 5 and 10 people. Fewer than 5 members on a team can prove to be nonrepresentative; there is more opportunity for individual bias affecting team activities; and there are fewer people to contribute to the work of the team. More than 10 members can become cumbersome and unwieldy; more time is consumed ensuring that everyone has an opportunity to voice their ideas; and it is sometimes more difficult for the group to reach a **consensus** on controversial issues. The smaller the team the better the chances of fast team action. Moreover, less effort is usually needed to reach **consensus**.

Ground Rules

One of the first things for team members to establish is a set of ground rules by which they will conduct all meetings. It is essential that everyone understand and agree to all the ground rules. The ground rules must be treated as inviolable by the team. Some typical ground rules are as follows:

- Everyone is equal.
- One conversation at a time.
- No meetings held without an agreed upon quorum.

- All decisions will be reached by **consensus**.
- The 100-mile rule is in effect (meaning, it is as though the meeting were being held 100 miles from the office—no interruptions).
- If requested, confidentiality will be honored by all team members (includes the facilitator and recorder).

There are, of course many other possible ground rules. Each team must decide which rules are important to them.

Roles and Responsibilities

Each team should elect a team leader or chairperson and a recorder. Rank or position in the company should not be considered a criterion for selecting a team leader. On long-term teams, the chairperson role is sometimes rotated every 6 months or every year. The responsibilities of the chairperson are to:

1. Call the meetings,
2. Reserve the meeting room,
3. Develop and distribute the agenda,
4. Focus on the content coverage of the session,
5. Assign action items,
6. Maintain all the official records of the meetings, and
7. Ensure compliance with the team charter.

The recorder records the highlights of the meeting, any action items that develop during the meeting, and other important discussion points. It is usually not necessary to keep verbatim minutes, but if this is felt necessary, then a professional recorder should be added. Normally, however, the recorder will just keep track of major items and prepare highlight minutes. Furthermore, the role of recorder is usually rotated at each meeting. That practice spreads the work load of recording over the entire membership.

Team Charter

Each team should be provided with a charter prior to their first meeting. The charter should be prepared by the management unit establishing the team. The charter should include the following items:

- The aim and scope of the team's activities
- The reasons for establishing the team

- The time frame for completion of the aim
- The scheduled time and place for the first meeting
- The resources available for the team
- Team membership list and facilitator's name

Meeting Frequency

How often a team meets depends upon the team's mission. Available time is also a major factor in determining how often to meet. Teams charged with a problem solving mission should meet as frequently as possible and for relatively long periods of time so that their mission can be quickly accomplished. Moreover, time is saved by meeting frequently because of the diminished need to review prior meetings. On the other hand, teams established to review and continually improve **processes** or **sub-systems** might not need to meet as often or for long periods of time.



THE GROUP MIND³⁵

The key to success in a meeting is teamwork. The cumulative effect of good teamwork can be envisioned as a **group mind** (See Figure 12). The **group mind** acts as one, understanding the strengths of each of its members and using this knowledge to pursue the team's mission. The power of the **group mind** should be obvious in that it pulls together the knowledge, skills, and attitudes of each individual into one collective mind. At the same time, the interference that so often intrudes with group meetings is suppressed to ensure positive movement toward group consensus and **win-win** solutions to problems. Though it is an ideal and often difficult to achieve fully, it does **optimize** the group capabilities when its principles are followed. One of the more effective tools of the **group mind** concept is brainstorming (See the discussion in Chapter 6.). Some key factors to be considered in order to achieve the **group mind** are as follows:

- All team members must be stakeholders in the mission of the group.
- All members must feel free to make suggestions.

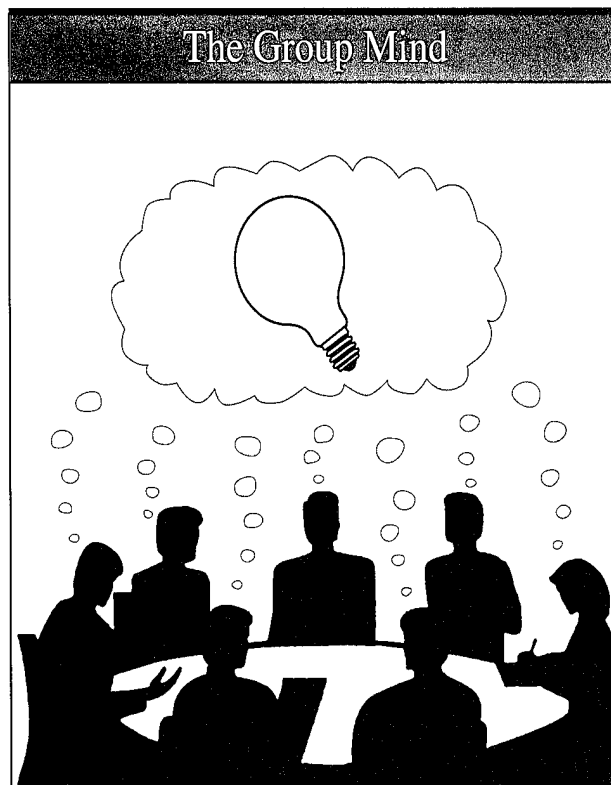

Figure 12. The Group Mind.

- All must trust the others, especially when sensitive issues surface.
- The team must desire **consensus**.
- All must subscribe to **win-win** solutions to problems.

Note that **consensus** does not mean anyone has to compromise. True **consensus** occurs when the solutions or ideas presented can be accepted by all members of the group as the most viable.

Some basic rules for assisting a team toward the **group mind** concept are as follows:

- Learn to listen to others' ideas without judging.
- Question ideas rather than questioning people.
- Ask for expansion or clarification of ideas.
- Don't dominate the conversation.
- Contribute to the conversation.
- Look for answers without losers — **win-win** solutions.

- Don't be locked in by old paradigms (old ways of thinking about things).
- Avoid disagreement — look for something good or something to build on in every idea.
- Avoid debating or fighting for an idea.
- Frequently review and summarize ideas, as you see them.
- Stay focused — don't jump ahead.
- Learn member strengths and exploit them.
- Listen!

Listen to the **process** operators. The team also needs to have a **linking pin** from the next higher level of management to ensure that the support is there from above and to facilitate good communications up and down the chain of command. In summary then, the members should be selected, by the following criteria:

- Willing to participate and enthusiastic;
- Suppliers to the **process**, if they are available;
- Customers of the **process**, if they are available;
- Key operators in the **process**;
- **Linking pin** from the next higher management level; and
- Availability to do the expected work of the team.

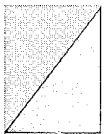

MEMBERSHIP CRITERIA

Several criteria are extremely important when selecting team membership. It is obviously important to select people who have the time to meet and conduct the probable work of the team. However, if certain people are critical operators of the **process** under study, make certain they are included on the team whether they have the time or not. The quality mission should take precedence over all others. Prospective team members should be willing to join the team and be enthusiastic about the team process. Ideally, those who supply something to the **process** (suppliers) and those who receive the output of the **process** (customers) under study should be represented on the team. Key to team membership, however, is to include those people closest to the operation of the **process** (**task** operators): the people who tighten the nuts, trim the produce, dot the "i's," and cross the "t's." It is their **process**. They should have some excellent ideas on how to improve it.

CHAPTER 6

CONTINUAL PROCESS IMPROVEMENT



CONSTANT CHANGE

Point 5 of Deming's quality philosophy is **Continual Process Improvement (CPI)** of the **process** and its output. This does not mean that we should be changing all **processes** all the time. It does mean that we should monitor all **processes** regularly, and, when the opportunity arises to eliminate unwanted variation or lessen the variation adversely affecting a **process**, we should proceed through the **PDSA** cycle to improve that **process**. Never be satisfied that a **process** is "tolerable" or "under statistical control." "If it ain't broke, don't fix it" does not apply in a quality culture.

All **processes** are in a constant state of flux. Sometimes they change ever so slightly and, other times, they change drastically within a short period of time. Obviously, improving or changing a **process** can at times be more costly and time-consuming than the **value-added** gain might seem to warrant. Nevertheless, to achieve and maintain a **quality** output, it is important that **CPI** be used for all **processes** in a quality culture-driven organization. Moreover, because **processes** are always changing, we should constantly and incessantly seek ways to improve those **processes**. We improve the **processes** in order to lessen the cost added by adverse variation and to increase the value and usefulness of the output for the customer.

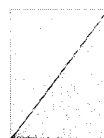

CUSTOMERS AND SUPPLIERS

Customers can be viewed at two basic levels. There are external customers and internal customers. The external customers are the ones we usually think about when we think of customers. They are the ones who purchase the products or the services. They write the checks. But there are other customers too. The internal customers are any of your company's employees who receive a product or service from any other employee or employees within the company. The engineers supply drawings to the shop foreman. The foreman is the engineers' customer, as is every employee who uses the drawings to construct the product. The people in shipping and sales are the customers of the shop. Employees submitting travel expense reports are customers of the accountants.

On the other hand, all these customers (external and internal) are furnished something by a supplier. The supplier, too, can be external and internal. More often than not, we all play the role of supplier and of customer at one time or another in our daily work activities. The engineers are suppliers in the example above, as are the foreman, the shop employees, accountants, etc. The suppliers must bear in the mind the needs and concerns of the customers. Business owners have internal suppliers and customers as well as external suppliers and customers. Everyone must key on their customers' satisfaction and reaction to products or services rendered.

CPI is a major factor in determining the reaction of customers to products or services. Business as usual might seem the shorter route to positive customer reactions, but as Figure 13 illustrates, the risks are far greater. The external customers' reaction to products or services can take the six forms seen in Figure 13. They are as follows:

1. The customer may brag about your product or service and remain a loyal customer;
2. The customer may brag about your product or service, but might be lured away by more innovative, more convenient, better quality products or services, etc.;
3. The customer may complain to you about the product or service received and remain a loyal customer, if your response is rapid and satisfactory;
4. The customer may complain to you about the product or service received and, without adequate response on your part, go elsewhere for future products or services;
5. The customer may say nothing but still remain a loyal customer as long as your product or service meets his needs; and

6. The customer may say nothing but might go elsewhere for the product or service you supply if its quality, innovativeness, convenience, etc. does not satisfy his needs.

It is, of course, reactions 2, 4, and 6 that all companies hope to avoid. That means lost business. But, these adverse reactions can be countered by ensuring that **CPI** is a normal part of your organization's culture. Beyond the seriousness of losing business, as you might with reactions 2, 4, and 6, is the higher cost associated with increased advertising, downsizing, reworking, etc. Additionally, **CPI** can save you costs by improving **processes** before they cause the problems that appear in reactions 3 and 4 above. Preventive measures, which **CPI** stresses, will normally cost far less than problem solving or fire fighting.

The first reaction is the one that every company wants. It is almost always necessary to be continually seeking ways to improve the products or services being offered and to meet with the customers' expectations. Moreover, **CPI** can carry you beyond the customers' expectations by anticipating need and creating better products and services. These are the ingredients that ensure customer

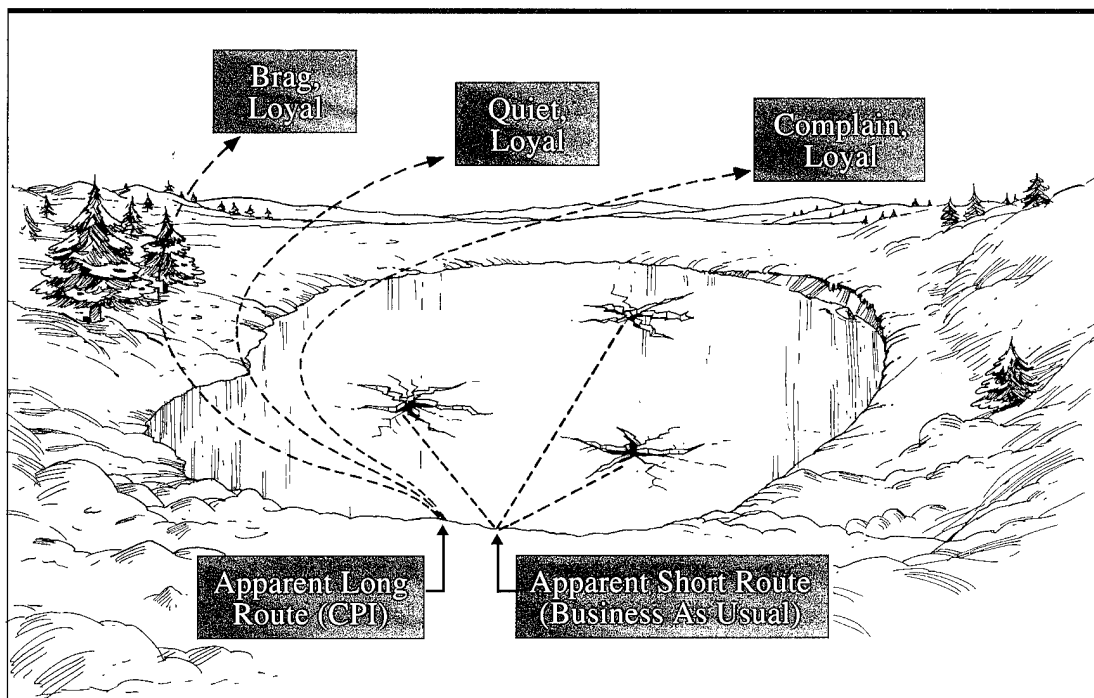

Figure 13. Customer Reactions—Avoiding Thin Ice.

loyalty. These are the things that keep your customers from going somewhere else for a product or service.

The third and fourth reactions are really opportunities for you. Once a customer has complained to you about a product or service, you have the opportunity to create a loyal customer by rapidly responding to the complaint and providing a product or service that meets or exceeds that customer's expectations. The danger in 3 and 4 lies in the customer complaining to other customers or potential customers. This can spread a bad reputation for your firm and eventual disaster. It is in your best interests to quickly mitigate complaints.

The majority of customer reactions normally falls in 5 and 6 above. The difficulty with these reactions is that they might often be unknown to you. Is the customer happy? Is the customer unhappy? Does your output meet the customers' needs or not? You can poll your customers, but you might not get forthright answers. How can you be sure your customers are satisfied? The answer is **CPI**. Moreover, **CPI** can take you beyond just satisfying your customers. Customers are often not aware how improved a product or service can be. Before we had microwave ovens to bake a potato in 4 or 5 minutes, we were delighted with the conventional oven that could provide enough heat to bake a potato in 45 minutes. Innovation, creativity and risk-taking are integral to **CPI**. They are often the key to increasing customer satisfaction by providing improved products or services the customer never dreamed were available.

The atmosphere that fosters innovation and creativity and allows risk-taking emanates from a quality culture-driven organization. In that type company, the **process** operators feel empowered to improve continually the **processes** on which they work. These employees feel free to take risks and seek innovative solutions without fear of reprisal. Therefore, management must not only take into consideration what the customers' needs and concerns are but also the ideas and recommendations the **process** operators have for improvements to the **process** and subsequent **value-added** products or services for the customer. (Refer to the earlier discussion on **empowerment**.)

At the same time, you need to listen to your customers so you understand what they want. The job of bringing your products or services up to a level that ensures customer satisfaction should be central to your operation. Along with that should be the desire to stay ahead of your customers' expectations so they are not lured away by more innovative products or services.

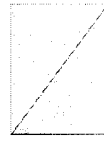

VOICE OF THE CUSTOMER/VOICE OF THE PROCESS

One of your major jobs, then, as a manager is to bring together the **voice of the customer** and the **voice of the process**. William Scherkenbach describes these two voices and the manager's responsibility to bring them together in his book, *Deming's Road to Continual Improvement*.³⁶ Scherkenbach calls the difference between the two voices the "gap."

The gap is the opportunity for improvement that exists within the **process**. However, the gap is not simply a difference between two static points. "It incorporates the location, spread, and shape of each voice."³⁷ Figure 14 on page 34 illustrates the two voices with a large gap.

The **voice of the process** is represented by the distribution of actual shipping times from the date of the order. The **voice of the customer** is represented by the distribution of shipping times requested by the customers of the **process**. The distribution in both voices is indicative of the variation that exists in both customers and **processes**. There are no two customers alike any more than two outputs of a **process** are alike. The **voice of the customer** does show a cluster at and near the center line. This center line can be referred to as the optimal point, the point where most customers are represented. It is the two optimal points in the **voice of the customer** and the **voice of the process** that management should seek to bring together, though merging the spread and the shape of each as well is the ultimate goal. The gap in Figure 14 shows that the capability of the current shipping process is unable to meet the **voice of the customer**. In all likelihood the **process** will have to be redesigned in order to close the gap that exists. Dramatic changes will be necessary to bring the two voices together.

Figure 15 on page 34 illustrates the two voices close to each other. In this case, the gap appears to be small enough, with sufficient overlap of the distributions, that continual improvement can bring the two voices into harmony. It shows that actual shipments have to a large extent met with the **voice of the customer**. Continual improvement of the **process** will help close the gap between the two voices.

The lesson of the two voices is that it is vital to bring the **voice of the customer** and the **voice of the process** together. Furthermore, it is management's job to ensure that

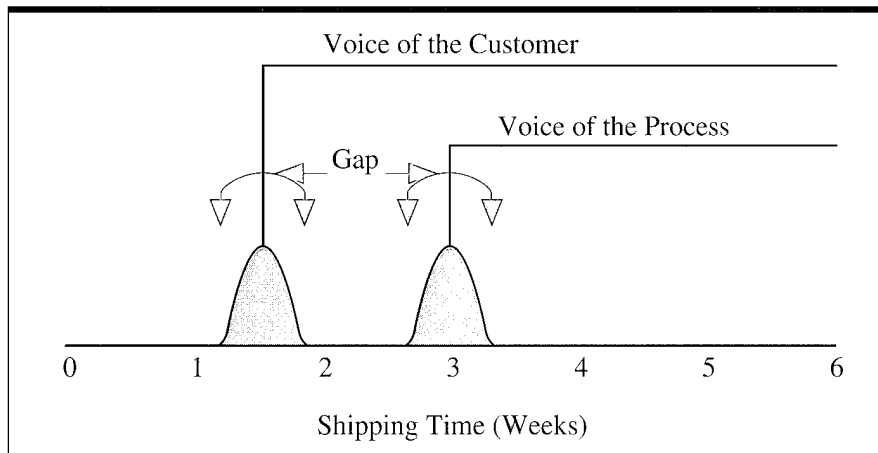

Figure 14. The Two Voices—A Big Gap.

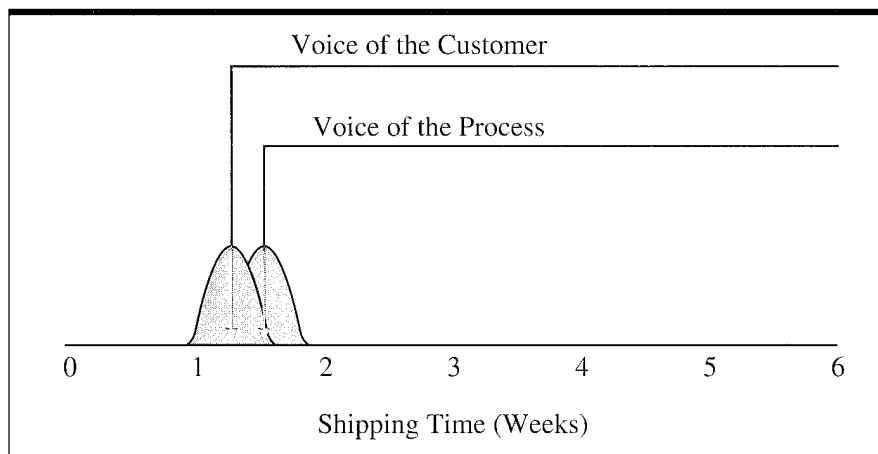
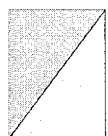

Figure 15. The Two Voices—A Small Gap.

this happens. Once that has been accomplished, management needs to monitor with **CPI** the changes in the voices to ensure they are kept together. Moreover, management needs to stay ahead of the **voice of the customer** by innovative, risk-taking efforts to improve the usefulness and desirability of the output of the **process**.

Taguchi. In what is probably a traditional way of envisioning customer quality requirements, there are established specifications with a low tolerance and a high tolerance. Scherkenbach refers to this as the “goalposts.”³⁸ Thus, with the goalposts concept, any output that falls within the range of the goalposts is considered to be a quality result, presumably meeting with the customers’ specifications. However, the loss function illustrates that any deviation from the distribution of the **voice of the customer** represents some loss, the amount of which depends upon how far the **process** output is from the optimal area, even though the output is within “specifications.” The goalposts, as a representation of customer specifications, and the loss function, with its delineation of loss, are illustrated in Figure 16.



THE LOSS FUNCTION

A different perspective of customer and process voices can be seen in the loss function developed by Genichi

As you can see in Figure 16, the Taguchi loss function illustrates the loss that occurs when concentrating on

customer specification limits as targets for output. The lesson of the loss function is to align the **voice of the process** with the **voice of the customer**, and, as Scherkenbach urges, seek to emulate the location, spread, and shape of the **voice of the customer**. That is the *optimal area* for the output of the **process**. To view your customers' requirements simply as though they fit between the goalposts will result in losses for your customers and for you. The loss function theory is crucial to continual improvement. It will help you minimize the loss.

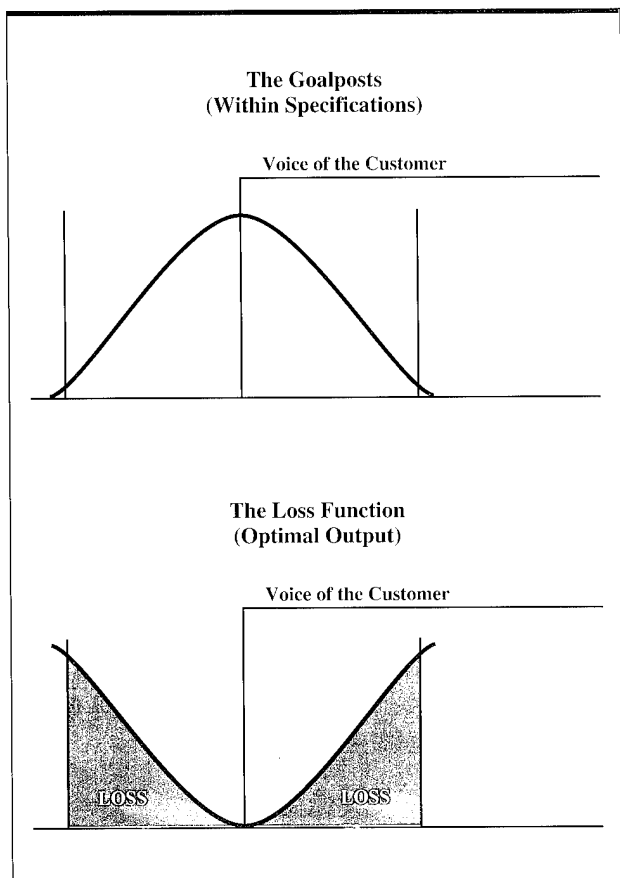

Figure 16. *The Goalposts and The Loss Function.*



PROBLEM SOLVING AND CPI

In many respects problem solving and **CPI** have the same purpose. The aims of each function are to single out unwanted variation in a **process**, find its causation, and establish changes or solutions to overcome or, at least, ameliorate the causes of the variation thereby improving the **process** and increasing the **value-added** features of the output. If a **special cause** exists, the **process** is unpredictable until the **special cause** has been removed or incorporated. In accord with the Deming philosophy, **CPI** should be a basic concept of any quality-driven company. It is an ongoing process. Too often the unwanted variation in **processes** is left untouched until it causes a major problem. Then the fire fight begins. Sometimes, as we have discussed earlier, the problem shows up in the form of customer complaints or lost business.

Nevertheless, the procedures and the tools used in firefighting, or problem solving, and in **CPI** are much the same. It is more comforting, however, to solve problems in a relatively unhurried process such as **CPI** rather than in the panic that usually accompanies fighting fires. This is not to mention the injury done to your standing with the customer receiving the faulty product or service or to your reputation as a result of the shoddy work. Why use your customers as filters for poor products or services?

The **PDSA** steps presented earlier represent a thorough, methodical approach to problem solving. It is difficult, particularly in firefighting situations, to take the time to follow each of the steps in that approach; but, properly done, the problem solving process is greatly enhanced. Even though the process cannot guarantee success, it can provide good insurance to protect against making changes that cause more problems than they overcome.

One of the most important elements of problem solving is information. Without the proper information problems cannot be solved with any degree of reliability. Solely using gut feelings to solve problems can often cause more problems than are solved. The **CPI** tools and techniques are intended to present and clarify information so it can be better understood where the causation lies and what kind of variation is affecting the **process**.

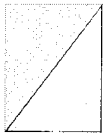

VARIATION

Few, if any, **processes** are ever constant; they are always in a state of flux. Over time the people, the materials, the environment, the methods, and the equipment change. These changes are called variations. **Common Cause** variations exist because of the **process** itself or the way it is managed. **Special Cause** variations are unpredictable abnormalities not part of the **process**. **Special causes** are often specific to the people, the materials, the environment, the methods, or the equipment involved with the **process**. At times they appear as a drastic abnormality that is not normally a part of the **process** or the way it is managed. When **special cause** variation is affecting a **process**, it is impossible to accurately predict what will occur in the **process**. The **process** is then considered to be unstable. You will recall it is management's job to predict. Therefore, the very crux of management's reason for being is affected when the **process** is unstable.

Common cause variation is to be expected in a **process**. When only **common cause** variation is affecting a **process**, it is possible to predict, within a range, what will occur in the **process**. The **process** is then considered to be stable. Obviously, it is desirable to be able to predict how a **process** will function. However, when **special causes** are affecting a process, it is not possible to predict how a **process** will function. As we will see there are some tests that can help us determine the presence of **special cause**.

Many times **special cause** variation is not readily apparent. The manager sees poor output and comes to a hasty conclusion about the cause. Often the employee is blamed for the poor output, when the fault lies in **special causes** or in the normal variation that occurs in that process. Sometimes the manager decides the **process** is faulty and changes the procedures or methods used, when the fault lies in forces outside the **process**. In either case, without the knowledge of what kind of variation is affecting the **process** to cause the poor results, the manager is acting blindly. The results can be disastrous and expensive.

Imagine a trucking company attempting to maintain a tight shipping schedule. One truck on a particular route suddenly begins to arrive at its destination consistently late. The manager, without attempting to understand the unwelcome variation, presses the driver to try to meet the schedule. The driver blames the heavy traffic. Occasionally, there is improvement. But the late arrivals continue. The manager offers bonuses to drivers who arrive on schedule. Still the one truck runs behind schedule. The manager threatens the driver with pay reductions, formal penalties and dismissal. The lateness continues. What should the manager do?

The manager has already made a thorough mess of the situation. The cause or causes for the lateness need to be uncovered. There appears to be a **process** shift in the case of this truck's route. The manager needs to find out whether the reason for the shift is **special cause** or **common cause**. If the reason is determined to be **common cause**, then ways should be found to improve the **process** in order to minimize the degree of lateness. However, careful investigation might find that the variation is **special cause**, such as a factory along the route that has changed its closing hour. The new closing hour happens to precede the time the truck is passing the factory. Thus, there is a sudden increase in traffic as the workers leave the factory. This is a **special cause** emanating from outside the trucking company's **process** but having a direct adverse impact on the route in question. With this knowledge the manager can change the roads the truck follows or change the time of departure so as to avoid the factory closing time. In this way, the manager can eliminate the **special cause** and bring the **process** back into control.

Proceeding as the trucking company manager did at first could have caused unwanted results. The driver might have tried to drive over the speed limit causing an accident or a speeding ticket. Or the driver might have gotten frustrated enough to quit under the pressure. Other drivers might have benefitted by receiving bonuses, but it would have resulted in considerable cost to the company. None of those actions would have resolved the unwanted variation. It is, then, important to determine the presence of **special cause** variation before taking action.

When **special cause** variation is located we should remove it; unless, the result of the **special cause** variation is an improvement in quality. In that case, it is desirable to attempt to locate the source of the **special cause** and somehow emulate it. More often than not, however, the task at hand is to remove the **special cause** variation. At this point it is very important to distinguish between **special cause** and **common cause**. To attempt to improve the **process** to adjust for **special cause** variation is likely to increase costs with no long-term gain. On the other hand, finding and removing the **special cause** of variation will improve the **process** and improve its predictability. If only **common cause** variation is affecting a **process**, the normal variation in a stable **process** can be dealt with by **continual process improvement** or by redesigning the **process** in order to improve it. Management very often makes the mistake of treating adverse variation as though it were **special cause**, when it is actually **common cause**. Another mistake management makes is to blame a variation on **common cause** when **special causes** are at fault.

The reasons for removing adverse **special cause** variation are:

- Reduce variation to improve predictability,
- Stabilize the **process** in order to improve it,
- Avoid having it come back and bite you when you least expect it,
- Reduce costs by eliminating unnecessary changes to **processes** and reducing dependence on inspection, and
- Improve the quality of output.

But, not all **special cause** is that easy to identify. The way to find a **special cause** is to use run charts and control charts. These tools require a sufficient number of data points plotted over time. Use of a control chart requires some statistical knowledge in order to determine the upper and lower control limits. There are several tests that can be used with run charts to provide indications of **special causes** in a **process**. Some guidelines and pitfalls for dealing with variation are shown in Figure 17.

Type of Cause	Action Taken	Result
Common	CPI or Improvement of the process	Good—Likely to improve output
Common	Adjust process to counter perceived special cause	Tampering—Likely to cause more variation
Special	Improve process to counter perceived common cause	Likely to increase cost forever
Special	Removing or incorporating special cause	Good—likely to increase predictability

Figure 17. Good and Bad Effects of **Process** Changes.

THREE IMMEDIATELY USEFUL TOOLS

There are many tools available for use in the **CPI** cycle. The three most useful, however, are flowcharts and, as mentioned, run charts and control charts. Flowcharts are very useful in visually displaying the steps in a **process**. Run charts and control charts are important for providing insight into the kind of variation and extent of variation that is affecting a **process**.

Flowcharts

It is almost always useful to flowchart the **process** under analysis. The values of flowcharting are as follows:

- Visualizes the entire **process** from beginning to end
- Illustrates the sequence of events
- Visualizes relationships between tasks in the **process**
- Highlights any duplication
- Highlights potentially unnecessary tasks
- Establishes the relative complexity of the **process**

Time, distance, weight, number counts, manpower levels, and such measures, can be added to flowcharts to add meaning and give more data for comparison purposes. When using flowcharts, it is best to use a consistent set of symbols to represent the different actions in the flow. Figure 18 shows some of the most used symbols. Many dictionaries have an extensive listing of flowchart symbols in their signs and symbols tables.

With very complex **processes** it is recommended that two flowcharts be prepared: one to show an overview of the major steps in the **process** and the other to show the detail. It is advisable to use the flowchart as a team effort. This collective approach will often provide better

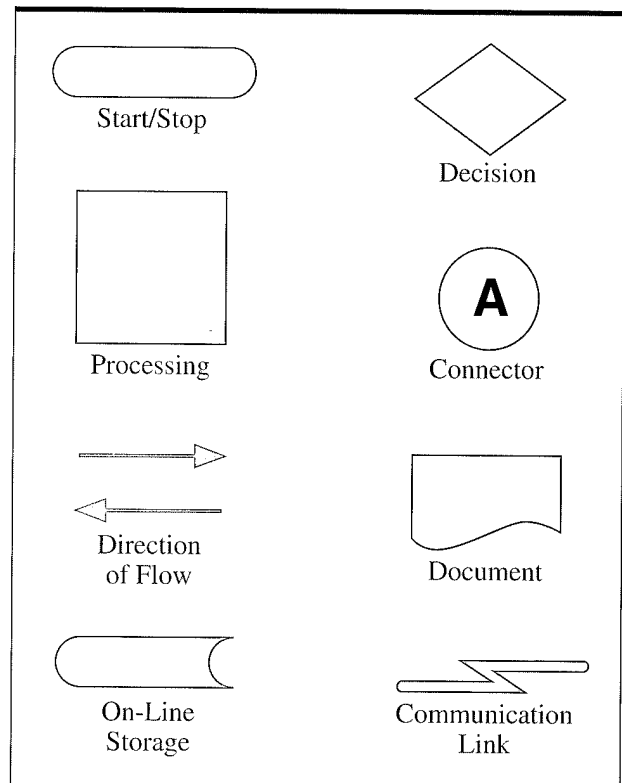

Figure 18. Flowchart Symbols³⁹.

coverage because people see different things in a **process**. One of the focuses of the flowchart is to determine the existence of duplicate and wasted tasks. The first flowchart of a **process** should illustrate the current situation, the way you think the **process** actually works now. Another chart might need to be prepared to illustrate how the **process** is *supposed* to flow, if that flow is different from the current situation. When reaching the solution stage of problem solving, it is often useful to create an *ideal* flowchart to illustrate a far simpler approach to accomplish the **aims** of the **process**. Figure 19 on page 39 is a sample flowchart.

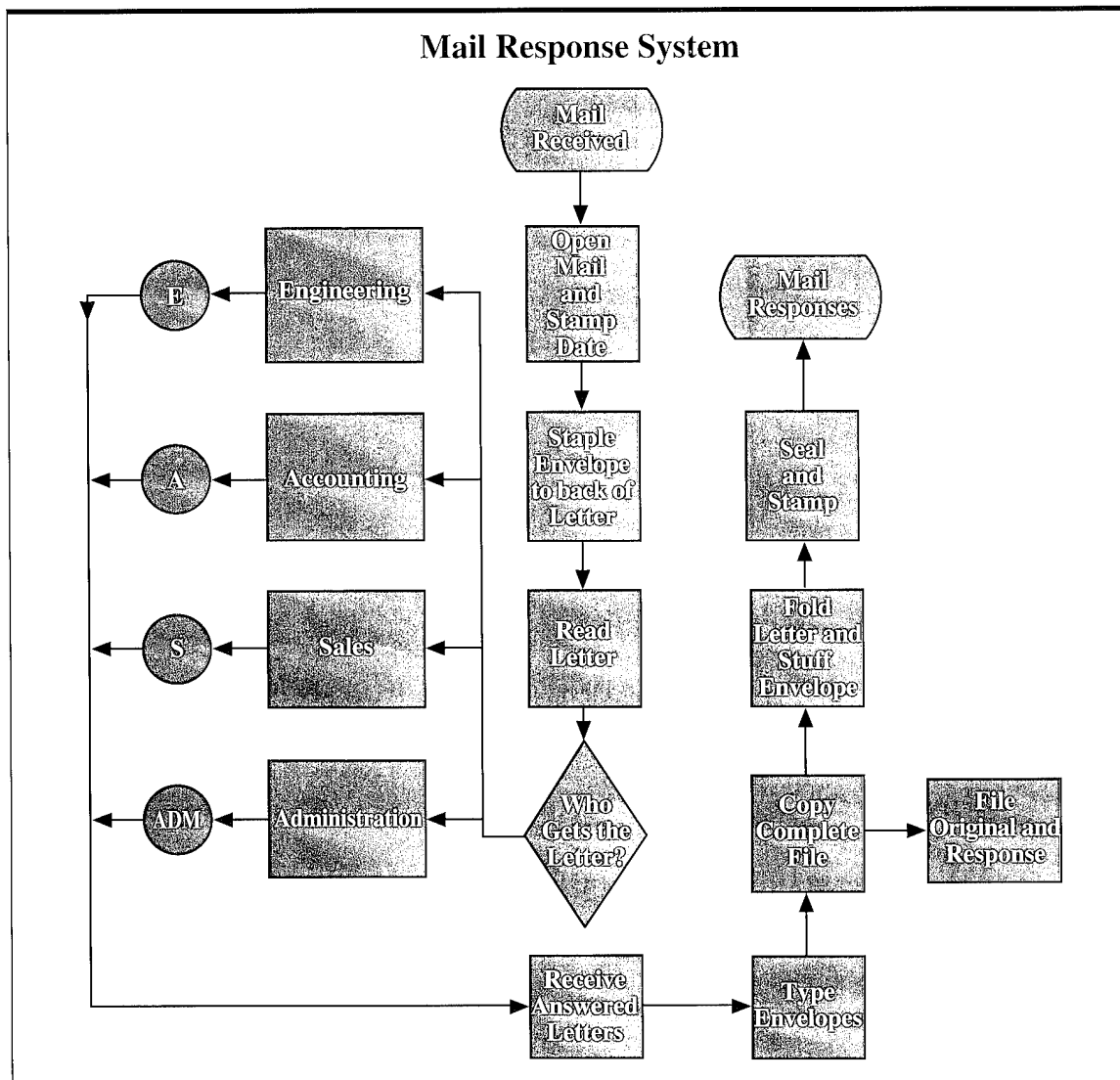

Figure 19. A Sample Flowchart.

Run Charts

The main use of run charts is to detect signals of **special cause**. The graphic representation of data in a run chart makes this possible. **Special causes** rarely can be detected by viewing tabular data. Moreover, the run chart helps describe the **voice of the process**. As noted earlier it is vital for management to be able to predict. In order to make sound predictions, the **processes** must be stable. Management needs assurance that **special causes** are not affecting the **process**. The run chart helps do that. The values of run charts are as follows:

- Assists in identifying unstable **processes**
- Signals **special cause** presence in a **process**
- Visualizes the extent of variation in a **process**
- Assists in identifying fudged figures or excess rounding
- Helps us make better decisions

The bottom line, or axis, of a run chart is called the “x-axis.” The far left line, or axis, is called the “y-axis.” The time sequence of the data is presented along the x-axis, from left to right, in the order generated. The measurements are aligned from low to high, bottom to top, along the y-axis. The data points are then entered on the run chart and connected by a straight line in the order they were generated.

To construct your run chart, first gather your data, make the entries on the run chart for each data point, then arrange the data on a separate sheet of paper in numerical

order. Count the number of data points and divide by two. If the number of data points is an odd number, round that number up to the next even number and divide by two. Then counting from the top or bottom of the data in numerical order determine the center point of the data as shown in the example below.

Draw the median line across the run chart at the 15 level on the y-axis. The run chart with an even number of data points and the calculated median as the center line is shown in Figure 20.

Odd Number (11)	Even Number (12)
19	19
18	18
16	16
16	16
15	15
15 (11+1=12÷2=6)	15 (12÷2=6)
15	15
14	14
14	14
14	14
14	14
14	14
	<u>13</u>

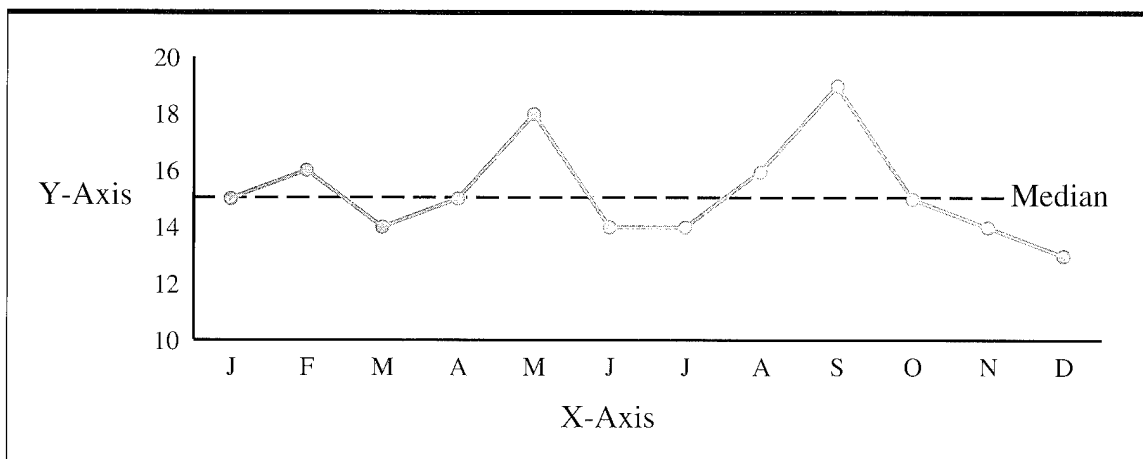

Figure 20. Run Chart with Median Line.

There are several available tests with run charts for determining the existence of **special causation** in a **process**.⁴⁰

Test 1. One means of using run charts to test for **special causation** involves first totalling the *runs* on the chart. A run is one or more consecutive data points on the same side of the median. To determine the number of runs, count the number of times the line connecting consecutive data points *crosses* the median. Add one to that number for a total number of runs in the run chart. Use that number with Table 2 to test for runs below the lower limit or above the upper limit. The first column of Table 2 is the total data points on the run chart other than those points that fall on the median line. When a run chart shows a number of runs that fall below or exceed the limits, it is a signal **special cause** variation is affecting the **process**.

Figures 21 and 22 illustrate the use of this test to detect signals of **special causation**.

Note that there are four run crossings of the median in Figure 21. Now add one to the total to get five. There are 19 data points not located on the median in the chart, so locate the number 19 in the first column of Table 2 and follow this row across to the second column, which indicates a minimum of 6 runs. One can conclude there is a signal of **special cause** in these data with only five runs where the table indicates a minimum of six runs.

Total data points on chart that are not on median	Lower limit no. of runs	Upper limit no. of runs
10	3	8
11	3	9
12	3	10
13	4	10
14	4	11
15	4	12
16	5	12
17	5	13
18	6	13
19	6	14
20	6	15
21	7	15
22	7	16
23	8	16
24	8	17
25	9	17
26	9	18
27	9	19
28	10	19
29	10	20
30	11	20

Table 2. Number of Runs Above and Below the Median.*

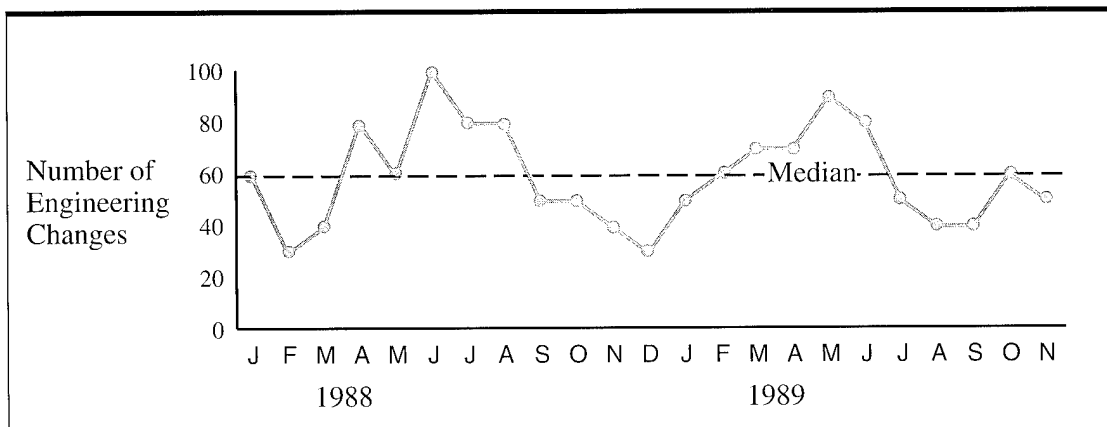

Figure 21. Too Few Runs.

*Adapted from lecture materials presented by Heero Hacgebord.

Figure 22 illustrates 16 median crossings. Add 1 to that to get 17. There are 21 data points not located on the median, so go to the 21 row in Table 2. The third column

indicates the upper limit of runs to be 15. Again there is a signal that **special cause** exists in the process represented by this chart because of too many runs.

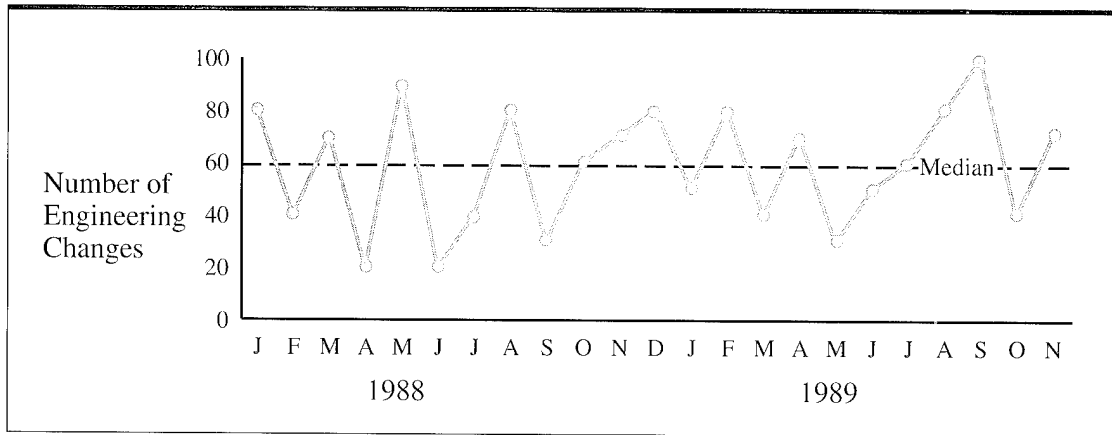

Figure 22. Too Many Runs.

Test 2. Another test using the median line on a run chart checks for runs that are too long. Ignoring any data points that fall on the median line, a run of eight or more data points in a run chart with 20 or more points is a good indication of **special causation**. A run of seven in a run

chart with fewer than 20 points is another indicator. Figure 23 illustrates this test.

Note in this illustration that there are nine data points in the run above the median signaling the presence of **special cause**.

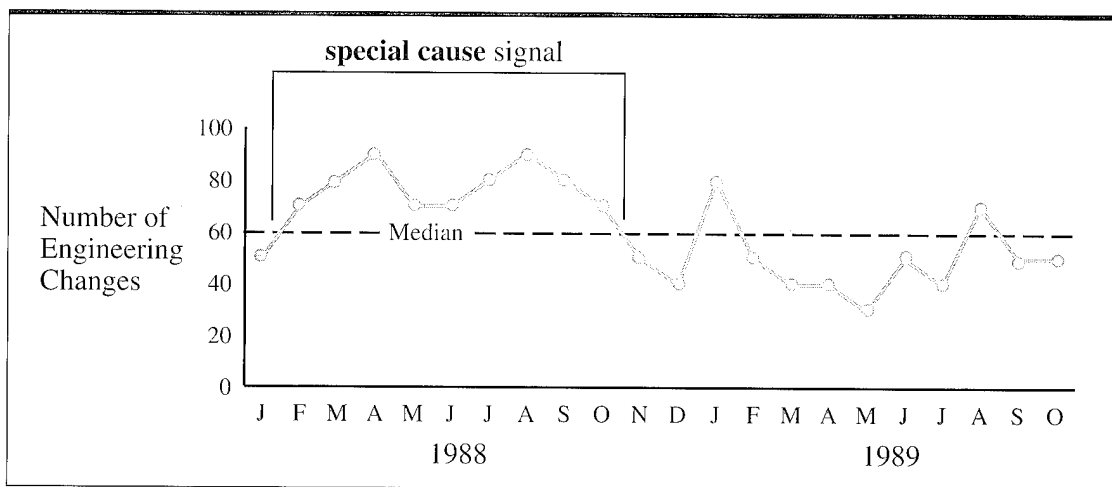

Figure 23. Runs Too Long.

Test 3. Testing for **special causation** without using the median line can be accomplished in several ways. Ignoring consecutive repeated values, a run of six or more points either increasing or decreasing in the same direction is an indicator of **special causation**. This test is illustrated in Figure 24.

Note that in Figure 24 the data points from April through November of 1989 are not considered a **special cause** signal because the August and September data points are the same thereby breaking the consecutive increase downward.

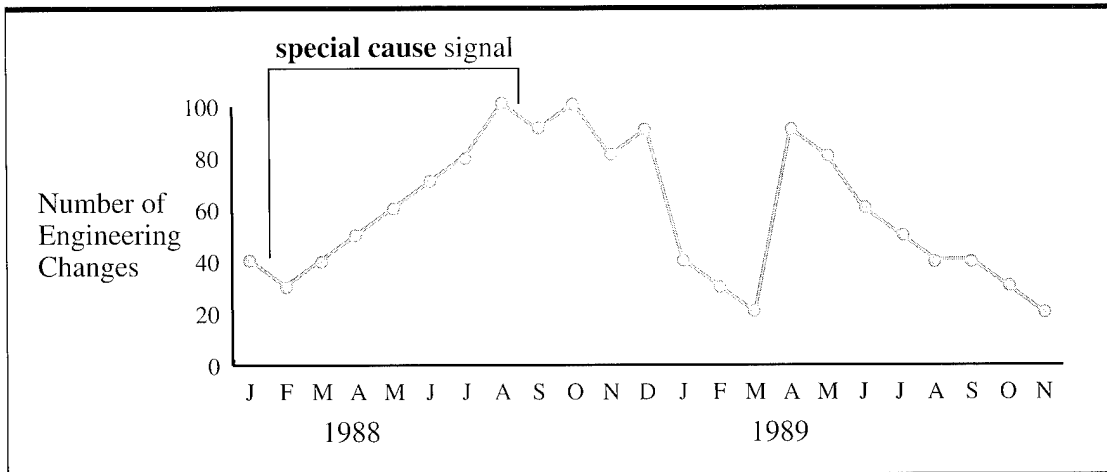

Figure 24. Trends.

Test 4. Sequences of 14 or more points alternating up and down in a saw-tooth pattern suggest the presence of a

special cause. This signal is illustrated in Figure 25. It is often the result of overadjustment or tampering with the **process**.

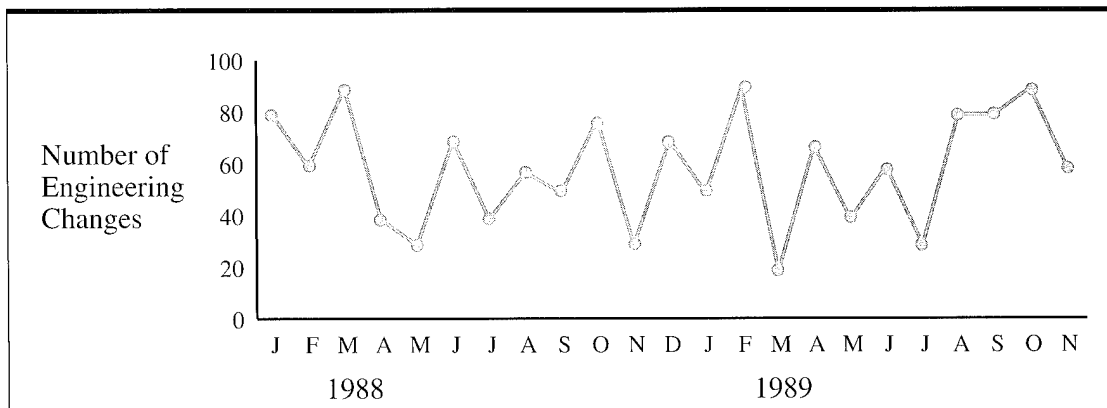

Figure 25. The Saw-Tooth Pattern.

Test 5. Sequences of seven or more consecutive points that have identical values also suggest **special causation**.

Often this filter indicates figure fudging or excessive rounding off. It is illustrated in Figure 26.



Figure 26. Too Many Identical Values in Succession.

Control Charts

The control chart is another way to describe the **voice of the process**. It has two basic uses: detecting **special cause** variation in the history of the **process** and establishing limits by which to predict the progress of a **process**. When the upper or lower limits in a control chart are exceeded by one or more data points, it is an indication of the presence of **special causation**.

The control chart is a time series chart, like a run chart, with an upper control limit and a lower control limit. However, the center line in a control chart is usually the average of the data, whereas run charts normally use the median of the data. Control chart limits are established by the use of historical data and a statistical formula. The limits are *not* set as management goals or targets nor are they customer specification limits.

The limits are guidelines for indicating **special causation**; they are not infallible. Occasionally, a **process** that appears to be stable—within the control limits—may actually be affected by **special causes**. The values of a control chart are as follows:

- Identifies whether a **process** has been operating under control
- Signals **special cause** presence in a **process**
- Visualizes the extent of variation in a **process**
- Uses control limits as a basis to establish a **process**' average and variability now and to predict it in the future

Setting control limits for control charts requires some statistical knowledge. There are several methods for setting control limits. One simple method for establishing control limits is as follows:

1. Gather data.
2. Total data.
3. Calculate data average by dividing total by the number of data entries. Data average = \bar{X} , or X bar.
4. Calculate the moving ranges ($m\tilde{R}$, or $m\tilde{R}$ tilde), differences between consecutive data entries, and reorder them high to low.
5. Determine the median of the moving ranges.
6. Multiply the median of the moving ranges by 3.14.
7. Add/subtract the result of step 6 to/from the data average to attain the upper/lower control limits.

This method of calculating control chart limits is shown in the example below and in Figure 27. Other tests for **special causes** using control charts are located in Appendix D. These tests and accompanying notes were developed by Dr. Lloyd S. Nelson and cited by Dr. Deming in *Out of the Crisis*.⁴¹

The control chart is similar in construction to the run chart. The x-axis and y-axis serve the same general purposes. As noted above, the median of the data points is ordinarily not used as the center line of the control chart. The more common center line in a control chart is the average (sometimes called the sample average) of the data. A common form of control chart uses the ranges that occur between consecutive data points to help in the calculation of control limits. Using the same data from Figure 27, we can calculate these moving ranges as follows:

Month	Datum Point	Range
January	15	1
February	16	2
March	14	1
April	15	3
May	18	4
June	14	0
July	14	2
August	16	3
September	19	4
October	15	1
November	14	1
December	13	1

Now reorder the ranges in numerical order to locate the median moving range ($m\tilde{R}$): 4, 4, 3, 3, 2, 2, 1, 1, 1, 1, 0. Divide the number of range points by two (in this case there are 11 range points, so we round up to 12) and use the result (6) to locate the sixth range from the top or bottom of the ranges in numerical order (2). We can calculate the sample average (\bar{X}) of our data by totalling the data points (183) and dividing by 12 to get an \bar{X} value of 15.25. We now have \bar{X} and \tilde{R} with which we can calculate the limits of the control chart. The formula for this calculation is as follows: $\bar{X} \pm (\tilde{R} \times 3.14) = \text{UCL/LCL}$.

Taking our data from above then we can fill in the formula as follows:

$$\begin{aligned} \bar{X} \pm (m\tilde{R} \times 3.14) &= \text{UCL/LCL} \\ 15.25 + 6.28 &= 21.53 \text{ UCL} \\ 15.25 - 6.28 &= 8.97 \text{ LCL} \end{aligned}$$

We can now add the limits to our control chart, showing an apparently stable process. The resultant control chart is shown in Figure 27 on page 46.

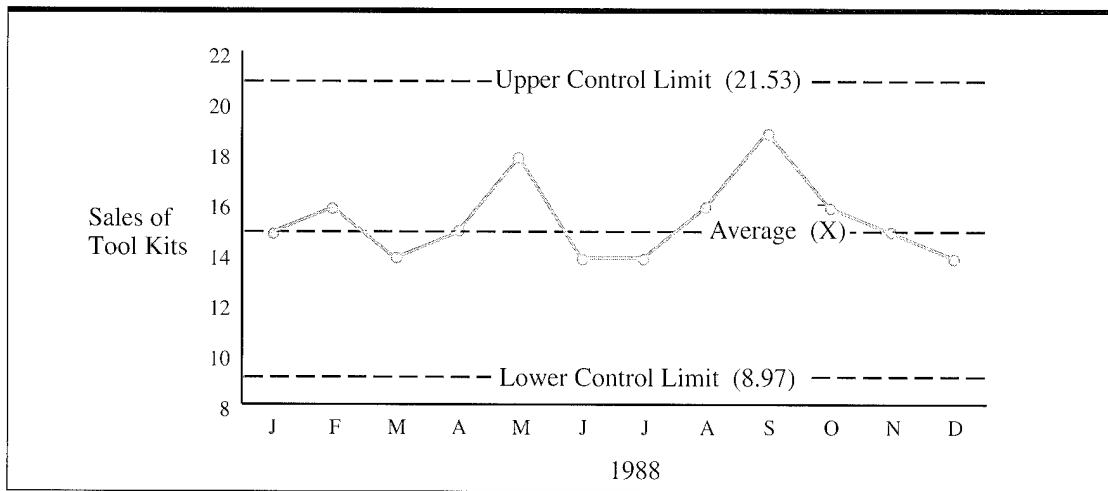

Figure 27. Control Chart with Limits.

This method of calculating control limits is often used when it is felt the control limits are inflated. This method's weakness is that the limits tend to be more variable than if the average range were used, given a stable process. Some other methods of calculating control limits include averaging subgroups of measurements and of ranges. These methods, however, are somewhat more complicated than the above formula, and for this reason are not included here. Refer to Don Wheeler's *Understanding Variation* for further guidance.⁴²

One caution here with control charts and run charts. If the **process** appears to be stable (passes the statistical tests and remains within the control limits), this does not mean that **CPI** is unnecessary. It might be comforting to know the **process** is in control, but it does not mean improvement is no longer needed. It does indicate though that it is unlikely that **special cause** variation is a factor in the **process**.



OTHER TOOLS

Cause and Effect Diagrams

Cause and effect diagrams are used primarily to assist in locating the causes of problems. They can take the form of the "fishbone chart" or can be done in outline form subordinating the causation factors until arriving at the basic causes. The values of using cause and effect diagrams are as follows:

- Helps organize major effects (symptoms) of problems
- Assists in evaluation of causation
- Illustrates relationships among problems and adverse effects
- Provides trail to follow when seeking primary causation

Figure 28 shows the outline format, often depicted in a fishbone diagram. The outline format delineates the causation factors so that the further to the right you look, the more primary the cause. The search for the primary causation of adverse effects assists in avoiding the mistake of treating the symptoms of a problem rather than treating the basic cause of the problem. In other words, be sure that you have isolated a cause of the problem not one of its effects. The typical problem has more than one cause, and efforts to uncover the so-called "root cause" may be mere exercise if other causation exists. If the root cause can be located and if it can be defined as the major cause for most of the bad effects, then by all means put a priority on removing that cause or ameliorating it. Figure 29 on page 48 is an example of a fishbone diagram. Note the major headings: people, methods, materials, environment, and equipment. They represent the usual inputs and outputs to every **process**.

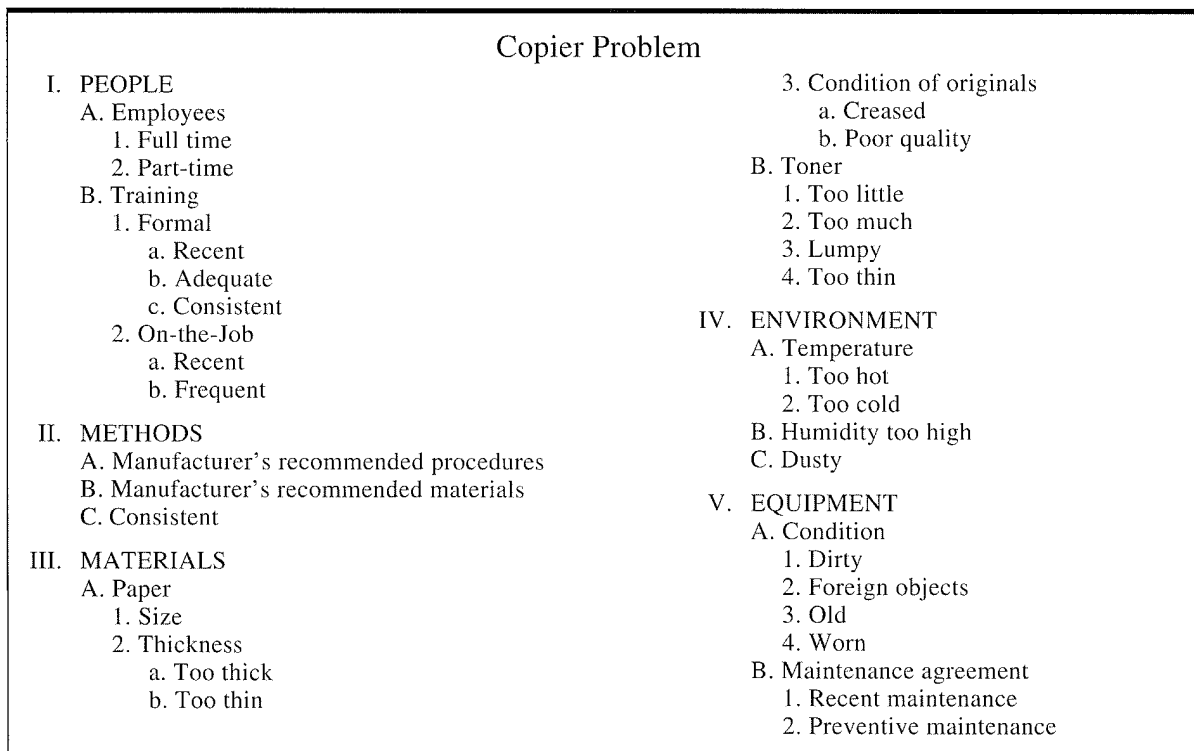

Figure 28. A Sample Cause and Effect Outline.

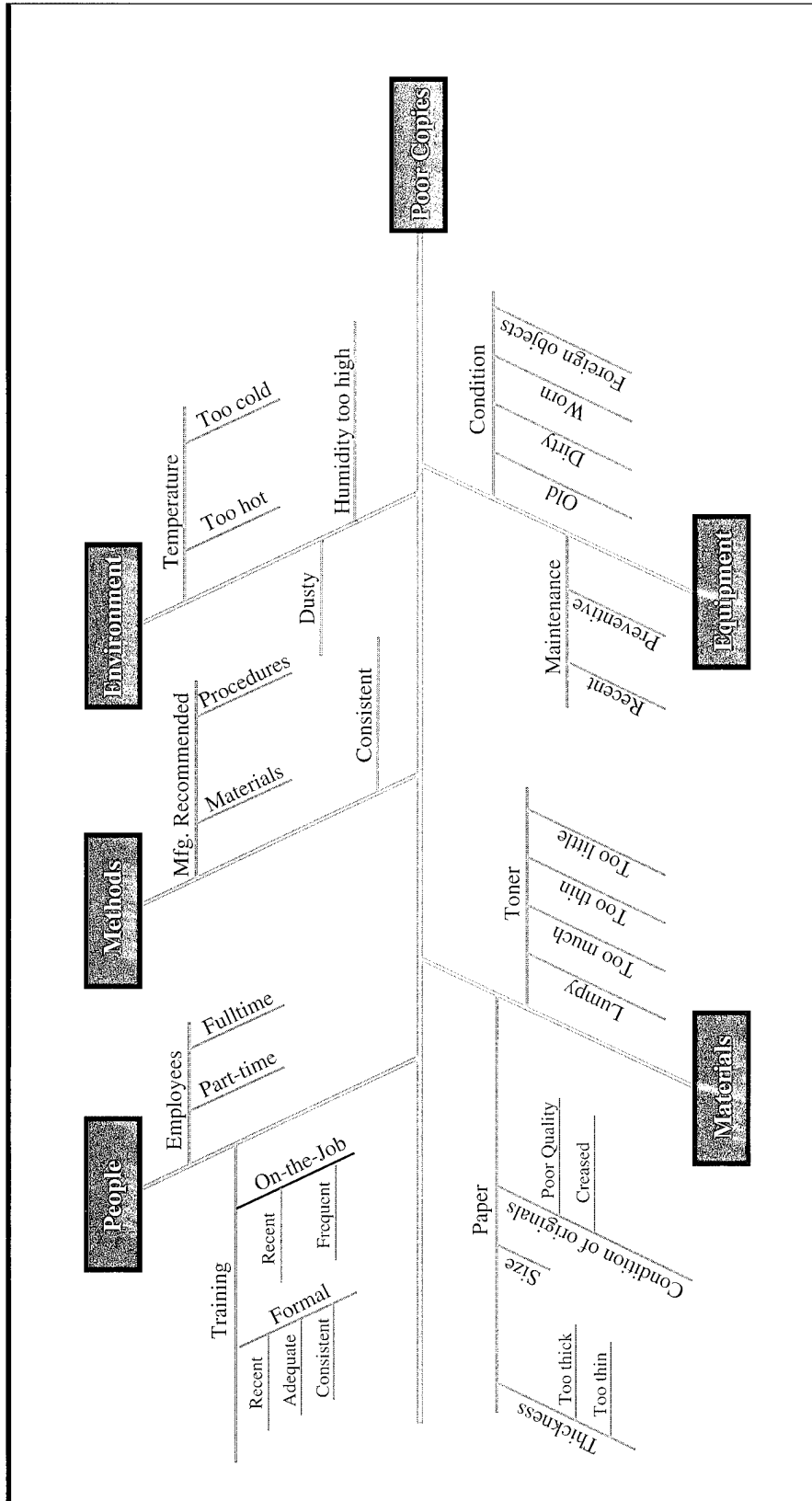

Figure 29. A Sample Fishbone Diagram.

Brainstorming

Teams may achieve the goals of the cause and effect diagram by using effective brainstorming techniques. In this procedure the group keys on the major effect of the problem. The aim is to present as many factors as the group imagination allows that might be causing the adverse effects. All ideas should be written down on flip chart paper, a white board, or other visual aid so that they can be viewed by the team. This will assist team members in building on other ideas to create new ones. When all ideas have been presented, the group then evaluates the stated causes and arrives at a **consensus** on causation. Once the causes of a problem are uncovered, it is essential to determine if **special cause** variation is present.

Brainstorming is a tool that can be used at almost all levels of **CPI**. It is often very effective in developing solutions to problems. It is very effective in creation and innovation efforts with teams. It can be done individually or in groups. It can be conducted silently or aloud. It is usually best to record all ideas presented so that the participants can clearly see them. The results of effective brainstorming are some of the fruits of the **group mind** concept. Some of the values of brainstorming are:

- Encourages creativity and innovation
- Encourages contributions from all team members

Checksheets

The checksheet takes many forms. Its basic purpose is to organize pertinent data in order to ensure certain **tasks**, events, measurements, and other essential elements take place as expected or planned. The values of a checksheet are as follows:

- Organizes pertinent data points for analysis
- Reminds us to complete all tasks in a **process**
- Provides an efficient means to collect data
- Visualizes patterns of data
- Illustrates sequence of events and relationships
- Provides opportunity to collect data for further analysis

As noted, the checksheet can take many forms depending on its purpose and the **process** in which it is used. It can be used as a control device to remind the operator that certain **tasks** need to be completed and to remind the operator of the sequence of those **tasks**. Checksheets can be used to record data or visually depict results as they occur. For example, the exact place a variation occurs can be recorded on a graphic depiction of the product under analysis. The time of the occurrence can also be recorded, and so on. A sample of a checksheet is in Figure 30.

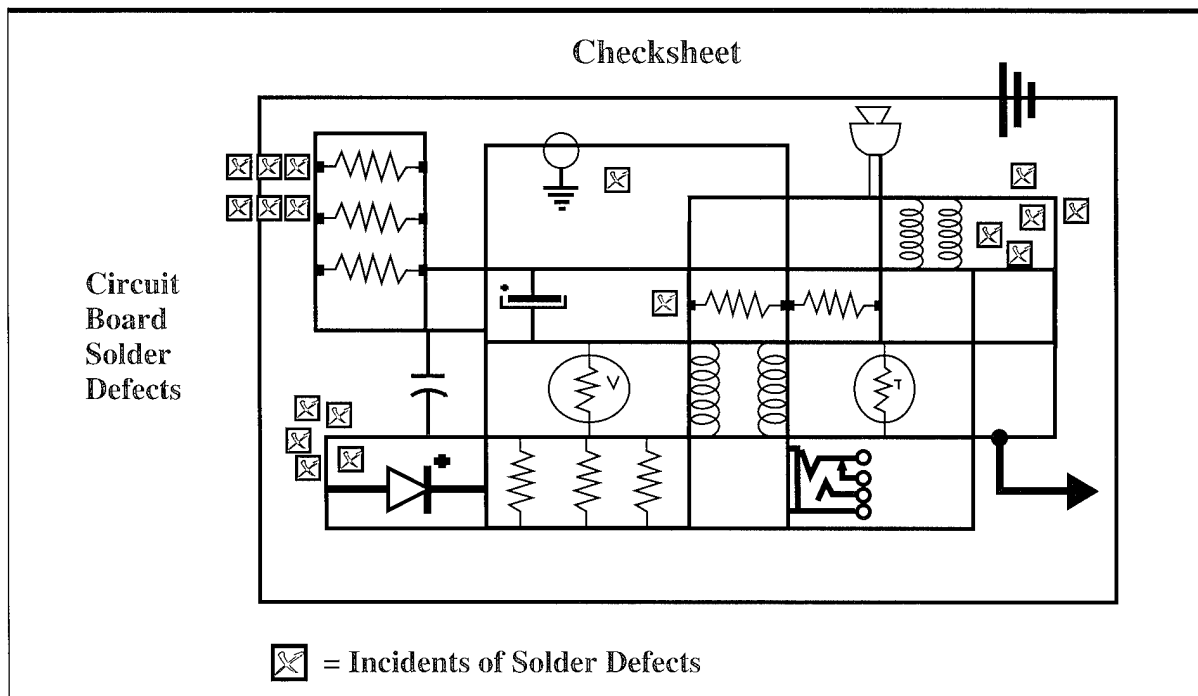

Figure 30. A Sample Checksheet.

Histograms

Histograms (bar graphs) organize and summarize data for visual analysis. The values of histograms are as follows:

- Allows rapid identification of the “shape” of data
- Facilitates comparisons among data categories

The histogram is a useful tool particularly when attempting to describe a **process** or **system**. Be alert, however, that to be effective histograms must be derived from *stable processes*. Histogram data are not in a time series, so one should be careful not to distort the meaning of the data by shielding it with a histogram. A histogram, as well as a table of the data, make good supporting material for run charts and control charts. A sample histogram is in Figure 31.

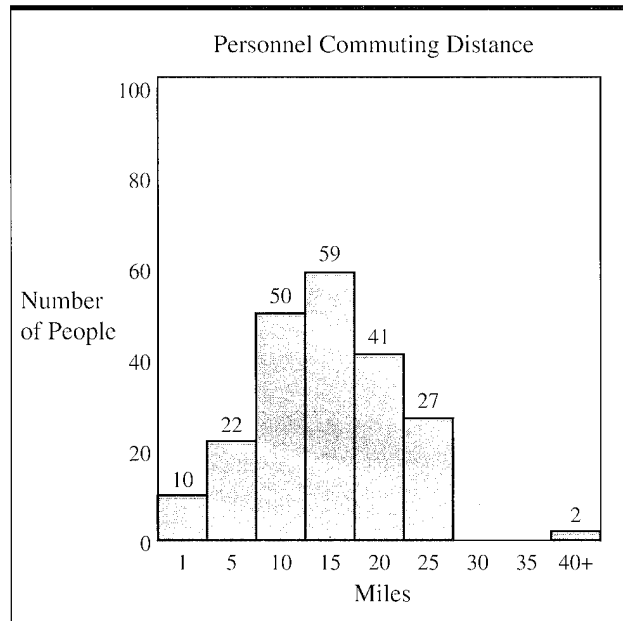

Figure 31. A Sample Histogram.

Pareto Charts

The Pareto chart is based on the premise that 80% of the adverse effects in a process come from 20% of the causes. The Pareto chart is a form of the histogram. The values of the Pareto chart are as follows:

- Assists in setting the priorities of causation
- Illustrates individual causation impacts

The Pareto chart is particularly useful where it is important and relevant to set the priorities of causation. Figure 32 is a sample Pareto chart. Note the line indicating the cumulative effect of the causation impacts.

There are many other tools that can be used to assist in understanding the **processes**, the problems and the adverse effects. See the books in Appendix B for further guidance.

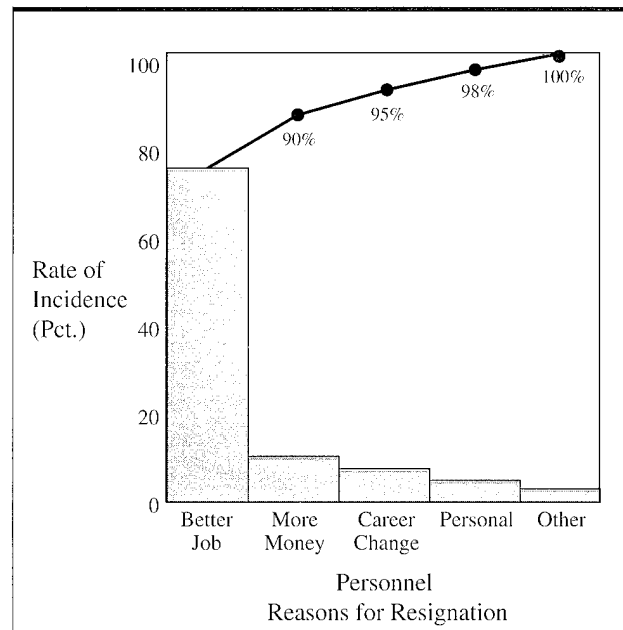

Figure 32. A Sample Pareto Chart.



MEASUREMENT

One of the major elements needed to determine the progress and success of your transition to a quality culture is your system of measurements. Measurements are necessary to locate your opportunities for improvement. They are necessary to prioritize these opportunities. They are necessary to help show you where to improve. They are necessary to evaluate the progress you have made. They are necessary to determine where you want to go. They are necessary to assure you that you have gotten there—or that you haven't. They play a major role in the **PDSA** cycle. Measurements are vital to any quality culture.

One of the first steps in using measurement is to determine what it is you want to measure. The best starting point is with the **key quality characteristics** of the product or service. **Key quality characteristics** are those elements most vital to the function of a service or product and most important to customers of the service or product. For example, some of the **key quality characteristics** of an automobile are good brakes and comfortable suspension. Some of the **key quality characteristics** of a payroll system might be on-time checks and accurate checks.

Once it is known which **key quality characteristics** are to be measured, it is necessary to provide clear operational definitions of them. An operational definition is "an agreement by a supplier and a customer that a certain procedure carried out by a supplier will be useful to them both. The usefulness of the operational definition is determined by the location, spread, and shape of the outcomes (**voice of the process**) relative to the aim (**voice of the customer**)."⁴³ A good operational definition will not only describe the appearance of the **key quality characteristic** but also the intent behind it. Moreover, an operational definition converts a concept into a measurement of some kind. As William Scherkenbach describes it, "operational definitions are the link between the letter of the law and the spirit of the law."⁴⁴ Defining on-time checks in the payroll system, for example, might involve stipulating the exact time span, designating where the check is to be delivered, or providing alternate procedures when the payment due date occurs on a holiday. It is particu-

larly important to define clearly and reach agreement with your customer on the **key quality characteristics** of the product or service you are providing. By "good brakes" does your customer mean front disk brakes, four-wheel disc brakes, or antilock brakes? Or does the customer mean some hard-to-define quality in the operation of the brakes described by negatives such as not jerky, not grabbing, or not mushy? It is important that the supplier understand as much as possible the operational definitions being used by the customer.

Operational definitions of **key quality characteristics** lead us to what we should be measuring. Then, we need to determine three vital things:

1. The method of measurement, or test, for each **key quality characteristic**,
2. The criteria for judgement or analysis of data, and
3. The decision as to whether the results indicate the degree that the criteria were or were not met.

One method for gathering useful data is to ask your customers. You might have already done this to determine the **key quality characteristics**. Other means of collecting data usually involve gathering numbers over time to provide useful data. You need to determine the scope of your measurements in order to ensure the validity of the resultant numbers. You need to determine the number of data points and the period of time over which they occur to ensure adequate coverage and to ensure the ability to test for **special causes**. You need to determine what tools will be used to assist you with the analysis. The flowchart, run chart, and control chart should almost always be used to analyze processes. Cause and effect diagrams/outlines, Pareto charts, and brainstorming are often used tools.

Measurements are very necessary after **process** improvement efforts have been taken. How well have you improved the **process**? Have you caused unforeseen variations by changing the **process**? Does the **process** need more improvement now? Should you change policy or permanently institute these changes? How well has the improvement team performed? All these questions come to the front after making changes to a **process**. A good system of measurements can answer all these questions. Measurements are a major part of the plan and study portions of the **PDSA** cycle.

CHAPTER 7

STRATEGIES

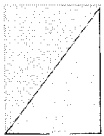

BEGIN THE TRANSFORMATION

There are a multitude of things an organization can do to get started on the **transformation** to quality management. However, there are a few important factors necessary in any successful QM effort:

- Start with top management support, nurture with top management support, and maintain top management “**constancy of purpose.**”
- Ensure that all personnel understand the organization’s **aims** and guiding principles.
- Ensure that all personnel have at least introductory training in the QM philosophy. Then, encourage and assist all personnel in further education and training.
- Ensure that **process** improvement teams receive timely training and proper facilitation.
- Delegate authority to the lowest appropriate level.
- Focus on meeting or exceeding the customers’ requirements.
- Make **CPI** the common practice throughout the company.
- Integrate the **PDSA** cycle into all company activities.

The path to QM is a long one and needs to be negotiated with care and with patience. The following are some typical steps to begin down this path.

PLAN

- Develop plans to train top management in the quality management philosophy.
- Develop plans to provide all employees with basic quality management training.

DO

- Train top managers.
- Train employees.

STUDY

- Assess management training.
- Assess employee training.

ACT

- Revise/institutionalize management training program.
- Revise/institutionalize employee training program.

PLAN

- Begin strategic planning with top management (Avoid emulating other companies. Do it your way!).
- Conduct **PDSA** steps outlined in Chapter 3.

DO

- Conduct strategic plan review with all employees (Listen to their suggestions, answer their questions, and make necessary revisions.).
- Begin strategic planning action items (Select small scale, relatively easy action items. This will build confidence and develop credibility for the **process**.).

STUDY

- Review action results.
- Review status of strategic plan.

ACT

- Institutionalize action steps deemed successful.
- Revise actions needing further work.

PLAN

- Decide how to recharge the company **infrastructure**.
- Develop action initiatives (Remain cautious, move slowly. Avoid overworking your personnel.).

DO

- Establish management teams and action teams where necessary.
- Develop cross-functional teams where **processes** involve more than one operating unit.

STUDY

- Analyze team recommendations.

ACT

- Respond to teams re: management decisions.
- Incorporate accepted changes or recycle efforts.

PLAN

- Review strategic plan.
- Revise and update action items.

These are just a few of the steps to begin the transition to a quality culture. It is important that training and education becomes a centerpiece in the plan for the future of your company. As Deming wrote, don't expect "instant pudding." Remain constant in purpose. Put the customer first. Continually improve your **processes, subprocesses, and the system**. Continue to use the **PDSA** cycle.

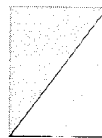

A LAST WORD

According to Dr. Deming, it is the unknown and unknowable that have the greatest impact on quality. Not all things can be measured. Not all variation is identifiable. Customers do not always accurately express their expectations. Employees who appear happy may be unhappy. Processes that appear stable may not be. Etcetera. The potential customers in the United States and in many countries around the world are becoming more and more conscious of quality. Whether your intended customer is DoD, other government agencies, or the general public, it makes sense to cut your costs by improving your quality thereby enhancing your products or services in the marketplace. The challenge lies with each of us to reach for the kind of business culture that will succeed in spite of the unknown and the unknowable. The quality management philosophy enhances the search for this culture.

Though, as noted in Chapter 1, large businesses in America have taken the lead in seeking quality improvement, many small businesses are beginning to seek a means to improve the quality of their output. The task for small businesses might seem formidable. It is a challenge. The streamlined nature of small businesses, however, and the lack of a "bureaucracy" to battle gives some advantage to the small business. And American small business managers are up to the task. The theories described in this handbook should help you develop the best direction for your company to take to improve quality. The rest is up to you. "Stay the course!" And as Deming was fond of saying, "Just do it!"

ENDNOTES

- ¹ Small Business Administration, "The State of Small Business: A Report of the President" (Washington, DC, 1991).
- ² Karen Bemowski, "Small in Size But Not in Stature," *Quality Progress*, (November 1992): 23-27.
- ³ Ibid., derived from data presented.
- ⁴ Mark Henricks, "Quality Makes a Difference," *Small Business Reports* 17, no. 12 (December 1992): 29-38.
- ⁵ W. Edwards Deming, *The New Economics* (Cambridge, MA: MIT Center for Advanced Engineering Study, 1993), 2.
- ⁶ U.S. Office of Personnel Management, *Introduction to Total Quality Management in the Federal Government*, Federal Total Quality Management Handbook series, #TQMHB-3, (Washington, DC: Federal Quality Institute, 1991) 19.
- ⁷ Bemowski, idem, *Quality Progress*, 9.
- ⁸ National Standards Association, Inc. (Gaithersburg, MD).
- ⁹ W. Edwards Deming, *Out of the Crisis* (Cambridge, MA: M.I.T. Center for Advanced Engineering Study, 1986), 3 (slightly modified).
- ¹⁰ Deming, idem, *Out of the Crisis*.
- ¹¹ Deming, idem, *New Economics*.
- ¹² Deming, idem, *Out of the Crisis*, the points are listed on pp. 23-23, and Deming follows with a detailed discussion of each point.
- ¹³ Ibid., the diseases are listed on pp. 97-98, and Deming follows with a detailed discussion of each disease.
- ¹⁴ Ibid., 126.
- ¹⁵ Ibid., 127.
- ¹⁶ Ibid., 128.
- ¹⁷ Ibid., 130.
- ¹⁸ Ibid., 130.
- ¹⁹ Ibid., 131.
- ²⁰ Ibid., 133.
- ²¹ Ibid., 133.
- ²² Ibid., 134.
- ²³ Ibid., 135.
- ²⁴ Ibid., 138.
- ²⁵ Ibid., 139.
- ²⁶ Ibid., 139.
- ²⁷ Ibid., 141.
- ²⁸ Ibid., 142.
- ²⁹ Ibid., 143.
- ³⁰ Deming, idem, *Out of the Crisis*, 23-148.
- ³¹ Deming, idem, *New Economics*, 60. Adapted from Deming's chart.
- ³² Deming, idem, *New Economics*, 125.

ENDNOTES

- ³³ Ibid., 52.
- ³⁴ Ibid., 92.
- ³⁵ This concept was used by William Bloom in group discussion classes at Bowdoin College during the 1960's and in training sessions for Process Action Teams in the Joint Chiefs of Staff at the Pentagon in the 1990's.
- ³⁶ William W. Scherkenbach, *Deming's Road to Continual Improvement* (Knoxville, TN: SPS Press, 1991).
- ³⁷ Ibid., 64.
- ³⁸ Ibid., 250.
- ³⁹ *Webster's Ninth New Collegiate Dictionary*, (1985), "Signs and Symbols," 1535.
- ⁴⁰ Much of the material in this section was gathered from one of Heero Hacquebord's excellent seminars, "Statistical Thinking for Leaders," presented at the Pentagon in 1993.
- ⁴¹ Deming, idem. *Out of Crisis*, 321
- ⁴² Donald J. Wheeler, *Understanding Variation, the Key to Managing Chaos* (Knoxville, TN: SPC Press, 1993).
- ⁴³ Furnished by William Scherkenbach, January 21, 1994.
- ⁴⁴ Scherkenbach, idem, 219.
- ⁴⁵ Lloyd S. Nelson, "Technical Aids," *Journal of Quality Technology* 16, no. 4 (October 1984), 238-239. This entire appendix is quoted directly from the above cited article.
- ⁴⁶ Generally, the individuals chart is based on "count" data usually determined by empirical observation. The X bar chart uses data comparing count data by measurements such as percentages. Both X bar and X charts normally use arithmetic averages to determine the centerline.
- ⁴⁷ Three sigma is the result one gets from using the various formulas to determine the upper limit and lower limit of a control chart. By breaking the control chart into sigma zones, Dr. Nelson provides a further ability to test for signals of **special cause** when the process appears to be within the control limits.

APPENDIX A

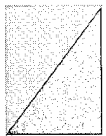

GLOSSARY

Aim. The purpose of a system, subsystem and process. The vital element of an organization that must be understood by all employees of the organization.

Common Cause. Any variation that is common to a process. When only common cause variation exists in a process, it is said to be stable, and predictions about the process can be made within a range of values.

Consensus. Agreement reached collectively by two or more persons with which everyone can abide though it might not be everyone's first choice. This agreement does not involve concessions or compromise on anyone's part.

Constancy of Purpose. The unflagging support needed for a quality culture, particularly by top management. The patience and persistence required over time to seek, to achieve, and to maintain a quality culture.

CPI. Continual Process Improvement. The ever-watchful tenet of the Deming theory of management that epitomizes the desire for better and better quality. Does not connote a constant improvement in a process but a continual awareness of processes and their changing need for improvement. Usually takes place in steps.

Empowerment. The act of enabling employees to make decisions, or at least recommendations for changes, with regards to the processes on which they work. Pushing decision-making to the lowest possible level.

Infrastructure. The organizational structure from which a company functions. In a quality-centered company, this structure is keyed to quality, good communications, and decision-making at the lowest reasonable level.

Group Mind. The cumulative effect of good teamwork. This concept is an ideal that envisions a synergy of the best in knowledge, abilities, and attitudes of all team members into one powerful, collective mind.

Key Quality Characteristics. Those elements most critical to the function of a product or service as envisioned by the customer of the product or service. It is important that the producer and customer agree to operational definitions of these characteristics.

Linking Pin. On quality teams the representative from the next higher management level who serves as the communication link to the team to ensure open communication lines and to ensure upper management support for the team's activities.

Optimization. Ensuring the system is as functional and effective as possible. This means the system's aim is being achieved, even though portions of the system may not be performing at their best. This requires a systems view.

PDSA. Plan-Do-Study-Act cycle developed by Dr. Deming. It is the guide toward learning and improvement, a procedure to follow to monitor processes/systems and to make changes.

Process. Any activity that takes an input, adds value, and produces an output. It always has a beginning and an end. Two or more processes make up a subsystem or a system.

Profound Knowledge. The philosophy espoused by Dr. Deming that centers on the theories of systems, variation, knowledge, and psychology—and their interrelationships.

Special Cause. Any variation that is caused from outside the process or that is not common cause. The existence of special cause variation in a process makes it an unstable process, and no reliable predictions about the process can be made.

Suboptimization. Said of a system that is not as functional and effective as it could be. Often characterized by internal competition or over-emphasized subsystems without regard to the aim of the system.

Subsystem. Comprised of two or more related processes, these units are the major parts of a system.

System. The whole organization, the company, that is the responsibility of top management. This is usually made up of two or more subsystems forming the whole.

Tasks. The steps in a process. The individual activities that make up the parts of any process.

Transformation. A change to a new paradigm of management (Deming). The necessary change to fully activate the quality-driven organization. It must be understood and desired by all members of the organization. It places the emphasis on the individual's and the organization's potential rather than on their past or present state.

Value-added Imperative. The requirement that every process add value to the input, which becomes the value-added product or service output of the process. If value is not added, consider abolishing the process.

Voice of the Customer. The distribution representing what the customers want. Management should seek to ensure that the voice of the process agrees with this distribution.

Voice of the Process. The distribution representing the output of the process. The control chart can be used to describe the voice of the process. Management should seek to close the gap between it and the voice of the customer.

Win-Win. The desired solution to problems and to company increased marketshare. In this scenario, there are no losers. Solutions or initiatives are sought that involve cooperation rather than competition.

APPENDIX B

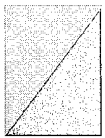

SUGGESTED FURTHER READING

- Deming, W. Edwards. Out of the Crisis. Cambridge, MA: M.I.T. Center for Advanced Engineering Study, 1986. (His initial book on quality management.)
- _____. The New Economics. Cambridge, MA: M.I.T. Center for Advanced Engineering Study, 1993. (The book reflects the maturity of Deming's philosophy, in particular with regard to **Profound Knowledge** — Must reading.)
- Ishikawa, Kaoru. Guide to Quality Control. Tokyo, Japan: Asian Productivity Organization, 1976. (Very heavy on the statistical approach to manufacturing, but most of the concepts can be translated to the service area.)
- Neave, Henry R. The Deming Dimension. Knoxville, TN: SPC Press, 1990. (A very helpful discussion of the 14 Points, the Deadly Diseases and the Obstacles.)
- Ott, Ellis R. Process Quality Control. New York, NY: McGraw-Hill, 1975. (A thorough statistical book directly related to the use of Control Charts.)
- Scherkenbach, William W. Deming's Road to Continual Improvement. Knoxville, TN: SPS Press, 1991. (Most recent book by one of the leading Deming Masters. This is Must reading for its discussion of the **Voice of the Process** and the **Voice of the Customer**.)
- _____. The Deming Route to Quality and Productivity. Rockville, MD: Mercury Press, 1987. (Good basic book relating the Deming philosophy.)
- Wheeler, Donald J. Understanding Variation, the Key to Managing Chaos. Knoxville, TN: SPC Press, Inc., 1993. (Excellent statistical book on variation. Short, to the point, description of control charts and formulas for calculating upper and lower control limits. Good for the busy executive who wants to understand the topic.)
- _____ and Chambers, David S. Understanding Statistical Process Control. Knoxville, TN: SPC Press, 1986. (A more detailed treatment of the topic for the lead mathematician/statistician.)

APPENDIX C

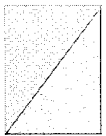

SOME DETAILED PDSA STEPS

Plan

1. Define the **process**.
 - Where does it begin?
 - Where does it end?
 - What does it do?
 - What is the **value-added imperative**?
2. Describe the **process**.
 - Have team Flowchart the steps.
 - Gather data to describe the **process** over time using such tools as run charts and control charts.
 - Establish the criteria that limit the **process** such as people, equipment, environment, materials, and methods.
 - Describe time and distance measures for **tasks**.
3. Describe the players.
 - Who are the external suppliers for this **process**?
 - Who are the ultimate customers for the output?
 - Who are the internal suppliers from **task to task**?
 - Who are the internal customers from **task to task**?
 - Who are the operators of the **process**?
4. What are the ultimate customers' expectations?
 - What does the customer expect of the output?
 - What does the customer do with the output?
 - When does the customer want the output?
5. What are the needs and concerns of the internal suppliers?
6. What are the needs and concerns of the internal customers?
7. What are the needs and concerns of the **process** operators?
8. Determine what historical data is available to understand the workings of the **process** and the expectations of the customer using such tools as customer surveys and checksheets.
9. Determine what data is needed to give a better understanding of the **process** and the expectations of the customer.
10. Determine what variations exist in the **process** and what problems are perceived.
11. Determine whether **special cause** variation is adversely affecting the **process** using run charts and control charts.
12. Use cause and effect diagrams or brainstorming to determine the primary causation.
 - Where does the customer want the output delivered?

13. Describe the effects of the variations/problems.
14. Set the priorities of the variations/problems using **special cause** variation as a first priority and Pareto charts for all variation.
15. Develop potential changes/solutions using brainstorming and cause and effect diagrams.
16. Test these changes/solutions against the earlier developed criteria and dependencies.
 - Are the criteria still met?
 - Might any of the dependencies be adversely affected?
 - Might any new adverse variations/problems be developed?

Do

1. If possible, conduct a pilot study to test the impact of the changes/solutions using customers over time.

Study

1. Study the results of the pilot study.
2. Determine whether value has been added to the output.
 - Will the output meet or exceed the customers' expectations?
 - Is the output better now than before the changes?
3. Develop measures of success or progress.
 - How will we know the changes/solutions are successful?
 - How can we monitor this success?
4. Develop implementation plan.
 - How are these changes/solutions going to be established?
 - When are they going to be established?
 - How do we standardize these changes/solutions?

Act

1. Standardize and establish changes/solutions.
2. Establish data collection to measure **process** activity.

Plan

1. Recycle the **PDSA**.
2. Establish regular period for review of the **process**.

APPENDIX D



CONTROL CHART TESTS⁴⁵

Refer back to Chapter 6, pp. 45-46, for the discussion on control charts. These are tests, other than the first listed, that can be used to detect possible **special cause** variation without regard to the upper and lower control limits.

Notes on Tests for Special Causes

1. These tests are applicable to X charts and to individuals (X) charts.⁴⁶ A normal distribution is assumed. Tests 1,2,5, and 6 are to be applied to the upper and lower halves of the chart separately. Tests 3,4,7, and 8 are to be applied to the whole chart.
2. The upper control limit and the lower control limit are set at three sigma above the centerline and three sigma below the centerline.⁴⁷ For the purpose of applying the tests, the control chart is equally divided into six zones, each zone being one sigma wide. The upper half of the chart is referred to as A (outer third), B (middle third) and C (inner third). The lower half is taken as the mirror image.
3. When a **process** is in a state of statistical control, the chance of (incorrectly) getting a signal for the presence of a **special cause** is less than five in a thousand for each of these tests.
4. It is suggested that Tests 1, 2, 3, and 4 be applied routinely by the person plotting the chart. The over-

all probability of getting a false signal from one or more of these is about one in a hundred.

5. It is suggested that the first four tests be augmented by Tests 5 and 6 when it becomes economically desirable to have earlier warning. This will raise the probability of a false signal to about two in a hundred.
6. Tests 7 and 8 are diagnostic tests for stratification. They are very useful in setting up a control chart. These tests show when the observations in a subgroup have been taken from two (or more) sources with different means. Test 7 reacts when the observations in the subgroup always come from both sources. Test 8 reacts when the subgroups are taken from one source at a time.
7. Whenever the existence of a **special cause** is signaled by a test, this should be indicated by placing a cross just above the last point if that point lies above the centerline, or just below it if it lies below the centerline.
8. Points can contribute to more than one test. However, no point is ever marked with more than one cross.
9. The presence of a cross indicates that the **process** is not in statistical control. It means that the point is the last one of a sequence of points (a single point in Test 1) that is very unlikely to occur if the **process** is in statistical control.
10. Although this can be taken as a basic set of tests, analysts should be alert to any patterns of points that might indicate the influences of **special causes** in their **process**.

Test 1. One point beyond Zone A

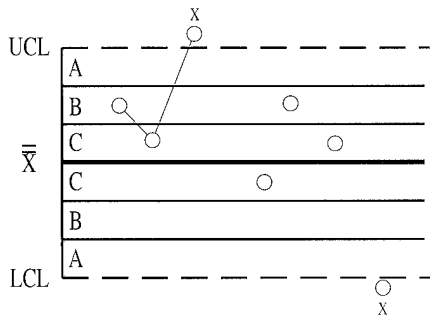

Test 2. Nine points in a row in Zone C or beyond

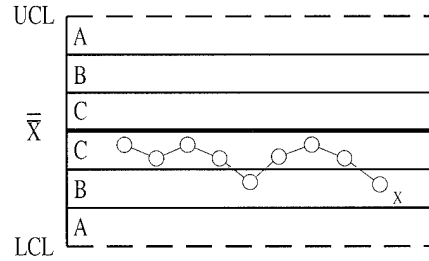

Test 3. Six points in a row steadily increasing or decreasing

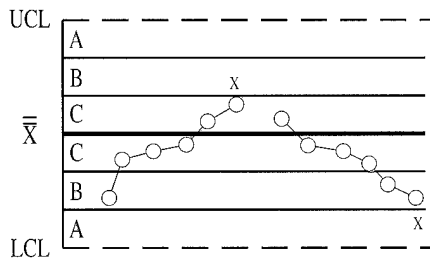

Test 4. Fourteen points in a row alternating up and down

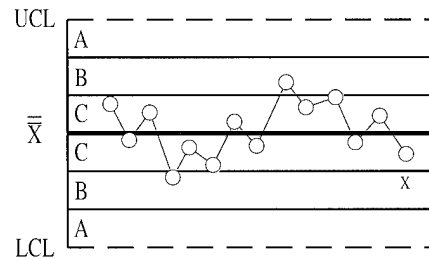

Test 5. Two out of three points in a row in Zone A or beyond

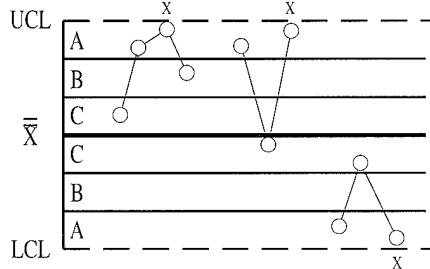

Test 6. Four out of five points in a row in Zone B or beyond

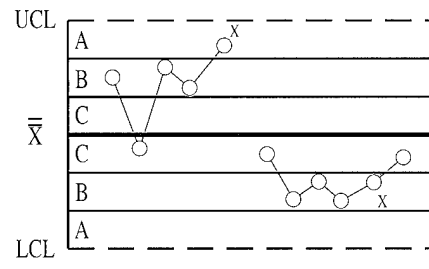

Test 7. Fifteen points in a row in Zone C (above and below centerline)

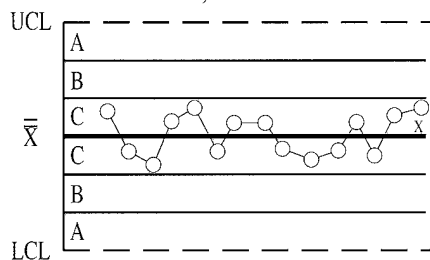

Test 8. Eight points in a row on both sides of centerline with none in Zones C

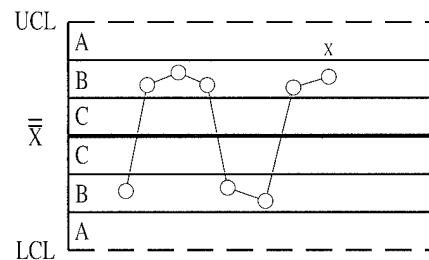

Control Chart Tests.

APPENDIX E

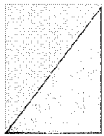

BIBLIOGRAPHY

- Bemowski, Karen. "Small in Size But Not in Stature." *Quality Progress* (November 1992): 23-27.
- Deming, W. Edwards. *Out of the Crisis*. Cambridge, MA: M.I.T. Center for Advanced Engineering Study, 1986.
- _____. *The New Economics*. Cambridge, MA: M.I.T. Center for Advanced Engineering Study, 1993.
- Hacquebord, Heero. Derived from seminar entitled, "Statistical Thinking for Leaders" (1993).
- Henricks, Mark. "Quality Makes a Difference." *Small Business Reports* 17, no. 12 (December 1992): 29-38.
- Ishikawa, Kaoru. *Guide to Quality Control*. Tokyo, Japan: Asian Productivity Organization, 1976.
- Joiner, Brian. *Fourth Generation Management*. New York, etal: McGraw-Hill, Inc., 1993
- Land, George and Jarman, Beth. *Breakpoint and Beyond*. New York, NY: Harper Business, 1992.
- Neave, Henry R. *The Deming Dimension*. Knoxville, TN: SPC Press, 1990.
- Nelson, Lloyd S. "Technical Aids," *Journal of Quality Technology* 16, no. 4, October 1984.
- Ott, Ellis R. *Process Quality Control*. New York, NY: McGraw Hill, 1975.
- Scherkenbach, William W. *Deming's Road to Continual Improvement*. Knoxville, TN: SPS Press, 1991.
- _____. *The Deming Route to Quality and Productivity*. Rockville, MD: Mercury Press, 1987.
- Small Business Administration. "The State of Small Business: A Report of the President." Washington, DC, 1991.
- U.S. Office of Personnel Management. *Introduction to Total Quality Management in the Federal Government*. Federal Total Quality Management Handbook series, #TQMHB-3. Washington, DC: Federal Quality Institute, May 1991.
- Webster's Ninth New Collegiate Dictionary*, Springfield, MA: Merriam-Webster Inc., 1985.
- Wheeler, Donald J. *Understanding Variation, the Key to Managing Chaos*. Knoxville, TN: SPC Press, 1983.
- _____. and David S. Chambers, *Understanding Statistical Process Control*. Knoxville, TN: SPC Press, 1986.