

PRICES SUBJECT TO CHANGE

0420118

N 7 5 - 1 8 1 0 5

**NASA TECHNICAL
MEMORANDUM**

NASA TM X- 62,401

NASA TM X-62,401

DISTRIBUTION STATEMENT A
Approved for public release;
Distribution Unlimited

**CHEMICAL RESEARCH PROJECTS OFFICE
FUEL TANK SEALANTS REVIEW**

R. W. Rosser and J. A. Parker

Ames Research Center
Moffett Field, Calif. 94035

19960227 054

December 1974

DYCO QUALITY INSPECTED

PLASTEC
22590

DISCLAIMER NOTICE

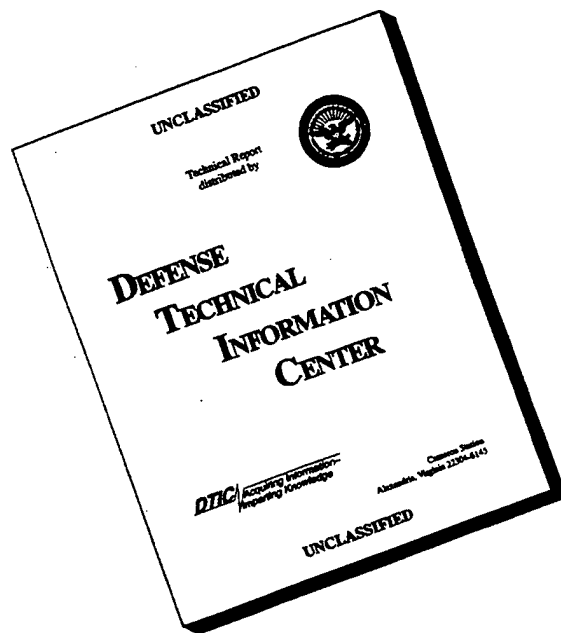

THIS DOCUMENT IS BEST QUALITY AVAILABLE. THE COPY FURNISHED TO DTIC CONTAINED A SIGNIFICANT NUMBER OF PAGES WHICH DO NOT REPRODUCE LEGIBLY.

1. Report No. TM X-62,401	2. Government Accession No.	3. Recipient's Catalog No.	
4. Title and Subtitle CHEMICAL RESEARCH PROJECTS OFFICE FUEL TANK SEALANTS REVIEW		5. Report Date	
		6. Performing Organization Code	
7. Author(s) R. W. Rosser and J. A. Parker		8. Performing Organization Report No. A-5820	
		10. Work Unit No. 743-32-01-01-00-21	
9. Performing Organization Name and Address NASA Ames Research Center Moffett Field, Calif. 94035		11. Contract or Grant No.	
		13. Type of Report and Period Covered Technical Memorandum	
12. Sponsoring Agency Name and Address National Aeronautics and Space Administration Washington, D. C. 20546		14. Sponsoring Agency Code	
		15. Supplementary Notes	
16. Abstract The status of high-temperature fuel tank sealants for military and potentially commercial supersonic aircraft is examined. The interrelationships of NASA's sealants program comprise synthesis and development of new fluoroether elastomers, sealant prediction studies, flight simulation and actual flight testing of best state-of-the-art fluorosilicone sealants. The technical accomplishments of these projects are reviewed.			
17. Key Words (Suggested by Author(s)) Fuel tank sealants Fluoroether polymers Fluorosilicone Flight testing		18. Distribution Statement Unclassified -- Unlimited STAR Category -- 23,27	
19. Security Classif. (of this report) Unclassified	20. Security Classif. (of this page) Unclassified	21. No. of Pages 151	22. Price* \$6.25

*For sale by the National Technical Information Service, Springfield, Virginia 22151

TABLE OF CONTENTS

Introduction, Dr. John A. Parker NASA - Ames Research Center	1
Program Overview, Dr. Robert W. Rosser NASA - Ames Research Center	6
AFML High Temperature Filleting Sealant Development and Evaluation, William F. Anspach Air Force Materials Laboratory	11
AFML Polymer Development for Elastomeric Sealant Applications, Dr. Christ Tamborski Air Force Materials Laboratory	14
Characterization and Degradation Studies of Sealant Candidates, Dr. Ming-Ta Hsu NASA - Ames Research Center	26
Functional Testing of Fuel Tank Sealant for Supersonic Airplanes and Adhesion Studies, Marlan Pollock The Boeing Company	34
Sealant Life Prediction Studies, Dr. Jovan Moacanin Jet Propulsion Laboratory	56
Perfluorinated Polyethers for Sealant Application Dr. Ralph de Pasquale PCR Inc.	72
Polyperfluoroether-1,3,4-Oxadiazoles and 1,2,4,H-Triazoles Dr. Donald Denson Stanford Research Institute	107
Fluoroether-1,2,4-Oxadiazole, Leonard O. Ross Stanford Research Institute	115
Study of Crosslinking and Degradation Mechanisms in Model Sealant Candidates, Dr. Kay L. Paciorek Ultrasystems, Inc.	121
Thermal and Solvent Stable Polymers: Synthesis of Terfunctional Monomers as Potential Crosslinking Agents, Dr. William D. Kray Talladega College	141

Introduction

Dr. John A. Parker

Welcome to the Ames Research Center and to the first NASA sponsored inter-agency review of the fuel tank sealants for application to supersonic aircraft.

It is the primary objective of this meeting to examine the status of the high temperature sealants technology base to determine if there are any easy opportunities to apply this technology to satisfy present operational requirements, on either military or potentially commercial (Concorde - etc.) aircraft.

To put the objectives of this program report on high temperature fuel tank sealants in perspective, it is worthwhile to review the early history of NASA's activities in this related SST requirement.

The search for improved polymers for the development of a sealant for SST application was instituted at NASA's Marshall Center. It comprised an in-house synthesis program leading to phenyl substituted siloxanes and a contract program resulting in a family of heterocyclic linked fluoroethers at Monsanto. The major milestone achieved by this effort was to demonstrate from the standpoint of thermal-fuel stability that linear perfluoroaliphatic ethers chain extended with aromatic imide-links were the best candidates discovered to date for this application. In general these materials were hard thermoplastics at room temperature and exhibited a glass transition in the temperature range of about 60°C. The Monsanto study eliminated other chain extension and crosslink structures on the basis of thermal stability, for example the isocyanurates. The program at Marshall was terminated with the demise of the American SST program.

The continuing search for improved candidates for high temperature fuel tank sealants was reinstated at the NASA Ames Research Center in the Chemical Research Projects Office with the new incentives of both NASA's SCAR program and continuation of DOT's effort to continue to evolve an advanced supersonic technology base.

A review of what had been accomplished synthetically suggested that the Dow Corning developmental sealant 77-028, a fluoroalkylsiloxane, and derivatives of the perfluoroethers offered opportunities for further development and exploitation. Boeing studies had shown that although the 77-028 had a tendency to degrade, but with the appropriate predictive analysis it might be useful in meeting the SST requirements. The Monsanto research suggested that with appropriate modifications to reduce the glass transition temperature and improve the efficiency of crosslinking processes that these basic materials have the potentiality of providing sealants with marked improvements in environmental stability.

Two years ago NASA, DOT and Boeing visited most of the Centers and talked with the principal investigators who had been concerned with the SST fuel tank sealant developments. The specific deficiencies of the base-line 77-028 sealant were identified to guide future developments. Three failure modes were evident from these discussions, namely reversion, low tear strength, and lack of reproducibility of adhesion to titanium.

Reversion: It is rather well accepted and well proven that the root cause of the observed degradation of the base-line sealant 77-028 is due to polymer reversion with the formation of cyclic tetramer from the principal chains. The practical results of this degradation process is the loss of sealant from

the seal rather than significant degradation in polymer bulk properties. For this reason compounded sealant shrinks in the joints. They seem however in the SST tank configuration to retain their inherent sealability (No-leaks). This phenomenon of reversion is generally characteristic of silicones and is a limiting factor in their application for continuous service at temperatures above 400°F. Although highly touted by some as a structure to block reversion, the cyanosiloxanes degrade rapidly after mild hydrolysis of the nitrile groups. New derivatives which have been proposed and synthesized for military application, the so called fluoro-silicone hybrids, have virtually eliminated reversion but have introduced the possibility of dehydrofluorination followed by oxidative chain scission. The new perfluoroether candidates suffer from none of these deficiencies.

Mechanical Tearing of Sealant:

Failure of sealant installation by the formation of cracks due to tearing of the sealant in the joint seems to be the most common failure mode. It seems to be an inherent difficulty with state-of-the-art formulated sealants, that they possess a rather large thermal coefficient of expansion and also exhibit a significant loss in tensile strength at elevated temperatures. These two properties couple to provide the tearing mechanism. A good possibility for eliminating their difficulty is the development of polydisperse blends, and graft or block polymers systems.

Adhesion Failure:

Difficulties with the sealant-primer-titanium interfaces manifest themselves in total lack of reproducibility in the measured peel strengths which can vary

by as much as two orders of magnitude. Just how significant peel strength is as related to failure is not clear. When coupled with chemically induced stress corrosion in the joint, the lack of integrity could completely degrade the interface structure.

From the foregoing considerations, some constraints on the evolution of new polymer types can be defined. The siloxane group is a weak link and should be reduced in concentration or blocked against reversion. Cyano substitution in siloxanes degrades stability. Vicinal substitution with HF may lead to instability and chemical stress corrosion. The perfluoro ether derivatives begin to meet most of these constraints, but require themselves innovations to reduce Tg's by chain extension and crosslinking control. Much of the chemical research to be discussed here will be concerned with characterization.

Sealant Failure Prediction Studies:

For many years Landel and Moacanin of JPL have studied elastomer failure by stress-strain measurements as a function of time, temperature, strain rate and other important parameters. The elastomers were assumed to be of constant molecular structure and the effects were not related to polymer structural degradation. What would be the net dynamic effect of uncoiling chains, straining and breaking chains while operating from a consistent polymer base, since reversion is the principal failure mode in fluorosiloxanes. To test these effects, models of varying crosslink density were found to obey the stress strain laws.

Flight Simulation:

In order to relate laboratory data to actual conditions, a small test tank was fabricated and placed in the Boeing SST flight simulator chamber. The tank was constructed to examine the three types of seals normally found in aircraft fuel tanks. However, the strain in the tank is difficult to assess, and correlation of laboratory and test tank data has not been possible to date.

Future Plans:

Contract efforts have provided an elastomer candidate with a low Tg and high thermal decomposition temperature. Under this AST program with shrinking funds we will not be able to complete all program phases so we must put our effort either into development of the rubber or into flight testing of best state-of-the-art materials.

In basic research, JPL can now advance theories to deal with polymers as they degrade and add kinetic studies to their rheology studies. However, basic research must be funded from applied programs. At this meeting we would like to entertain a critical examination of the material presented.

Advanced Supersonic Aircraft Fuel Tank Sealants

Program Overview

Dr. Robert W. Rosser

The objective of this program is to produce a flight-proof, fully characterized, predictable fuel tank sealant that meets supersonic aircraft requirements.

Figure 1 indicates interrelationships of the fuel tank sealants program. These activities comprise synthesis and development of new fluoroether elastomers, sealant prediction studies, flight simulation, and actual flight testing of best state-of-the art sealants. Figure 2 summarizes the schedule of the overall program.

Both new extension and new branching reactions that can be carried out with hexafluoropropylene oxide oligomers are under consideration. The reactions of these polymeric intermediates through nitrile cyclizations to give triazines, and nitrile co-reactions with nitrile oxides to give polyoxadiazoles are two principle systems which are being studied. Figure 3 shows representatives of the two systems under investigation with an estimation of their service limitations in the development of high molecular weight perfluoroethers having satisfactory mechanical properties at below -10°C .

In principal, the desired predictive method can be developed from a suitable combination of viscoelastic measurements (leading to the construction of a characteristic failure "property surface" for the elastomer) and stress-relaxation measurements (which assess

the extent and contribution of chemical degradation in these materials). Previous work at JPL has led to the development of short-time test methods which enable predictions to be made of the lifetime of elastomers under operating conditions, but in the absence of chemical degradation. From other studies, methods were also developed for measuring network degradation kinetics for elastomers exposed to a fuel environment at elevated temperatures; these were principally adaptations of classical chemorheological techniques. Efforts are being made to show that these methods can be combined to yield a satisfactory prediction of long-term aging using short term tests.

Actual time simulated tank studies are being conducted at Boeing. The experimental fluorosilicone sealant is installed in a test chamber which subjects it to pressures and temperatures of the flight cycle. Simultaneously, the tank is subjected to spanwise and chordwise loading representative of the fatigue spectrum expected under the most severe flight conditions.

The fluorosilicone DC77-028 is considered the state-of-the-art sealant candidate to date and efforts have been made to correlate its behavior in prediction studies and flight simulation. The DC77-028 will shortly be tested on the YF-12 NASA aircraft along with a modified version FCS-210 fluorosilicone-fluorocarbon hybrid. Correlation of the 3 test programs will then provide a baseline for future testing of new elastomeric candidates in subsequent flight cycles.

AST FUEL TANK SEALANTS PROGRAM
INTERRELATIONSHIPS

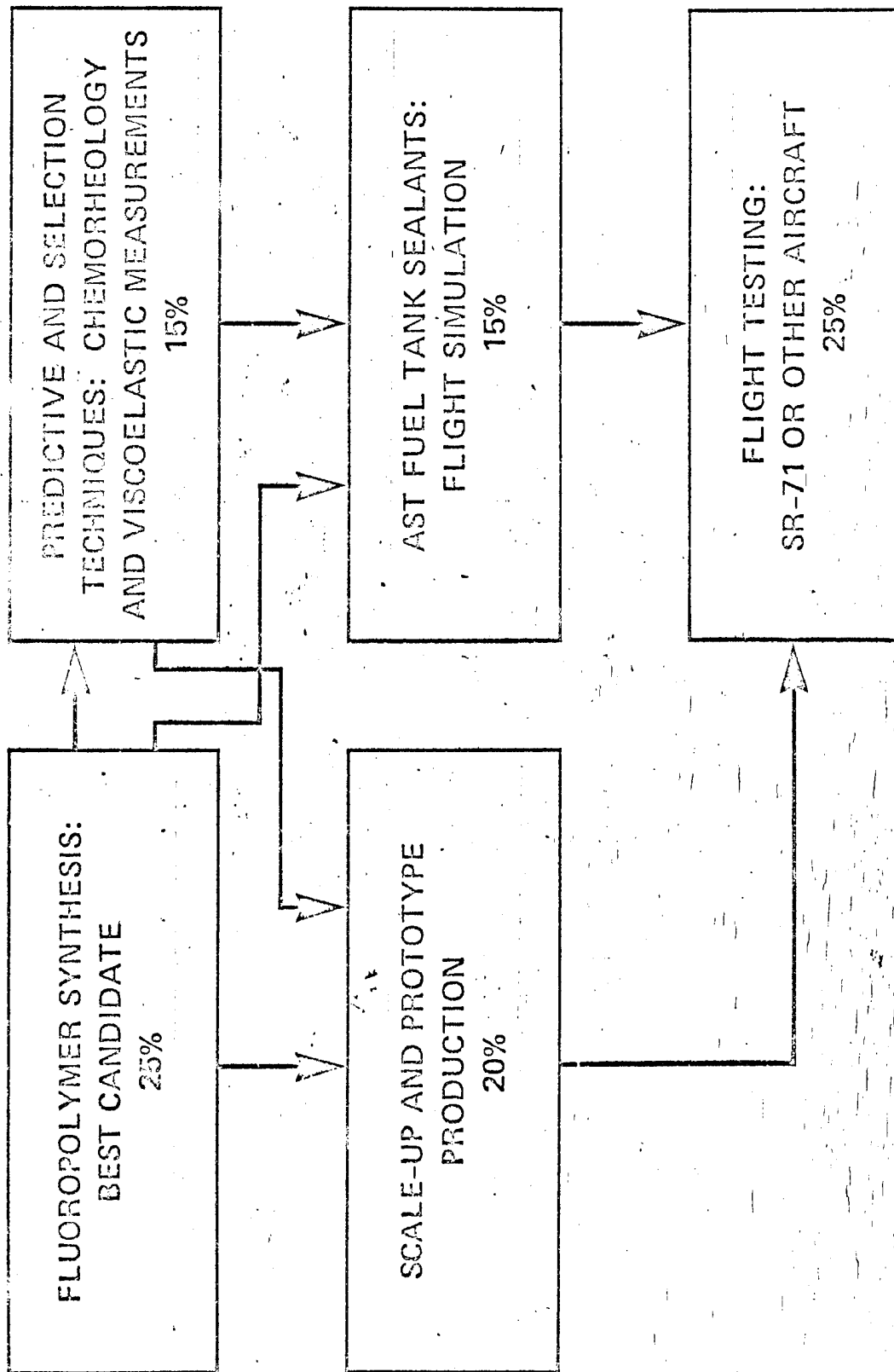

Fig. 1

HETEROCYCLIC - PERFLUOROALKYLENE ETHER COPOLYMERS

FLUOROETHER BACKBONE	CONTINUED SERVICE TEMPERATURE, °C	T _g , °C	CROSS-LINK
$\left[\begin{array}{c} \text{CF}_3 \\ \\ \text{N} \\ // \\ \text{CF} \\ \\ \text{O} \end{array} \text{---} \text{CF} \left(\begin{array}{c} \text{CF}_3 \\ \\ \text{O} \end{array} \text{CF}_2 \text{CF} \right)_m \text{---} \text{O} \left(\text{CF}_2 \right)_5 \text{O} \left(\begin{array}{c} \text{CF}_3 \\ \\ \text{O} \end{array} \text{CF}_2 \text{CF} \right)_n \text{---} \text{CF} \left(\begin{array}{c} \text{CF}_3 \\ \\ \text{O} \end{array} \text{CF}_2 \text{CF} \right)_x$	230	-43	CN
$\left[\begin{array}{c} \text{CF}_3 \\ \\ \text{N} \\ // \\ \text{CF} \\ \\ \text{O} \end{array} \text{---} \text{CF} \left(\begin{array}{c} \text{CF}_3 \\ \\ \text{O} \end{array} \text{CF}_2 \text{CF} \right)_m \text{---} \text{O} \left(\text{CF}_2 \right)_5 \text{O} \left(\begin{array}{c} \text{CF}_3 \\ \\ \text{O} \end{array} \text{CF}_2 \text{CF} \right)_n \text{---} \text{CF} \left(\begin{array}{c} \text{CF}_3 \\ \\ \text{O} \end{array} \text{CF}_2 \text{CF} \right)_x$	260	-50	C ₆ F ₅ OR CN

AST FUEL TANK SEALANTS PROGRAM
MILESTONES

TASKS	FISCAL YEAR:					
	1973	1974	1975	1976	1977	1978
ELASTOMER SYNTHESIS AND CHARACTERIZATION						
PREDICTIVE TECHNIQUES: LONG TERM STABILITY						
SCALE-UP AND PROTOTYPE PRODUCTION						
FUEL TANK SEALANTS: FLIGHT SIMULATION						
FLIGHT TESTING: SR-71 OR OTHER AIRCRAFT						

Fig. 3

AFML HIGH TEMPERATURE FILLETING
SEALANT DEVELOPMENT AND EVALUATION

William F. Anspach

I. General

In the past the AFML has conducted an aggressive program to develop high temperature filleting sealants resulting in excellent sealants based on fluorocarbons and fluorocarbon hybrids. Emphasis is currently being shifted to channel sealants for service up to 450°F. This shift is based on revised USAF requirements. Also, a dynamic test capability has been developed which provides data directly correlatable to flight test data.

II. Fluorocarbon Sealants

In 1962 requirements were established for an integral fuel tank sealant for use at 350-550°F. An excellent high solids material was developed, based on blends of Viton B/Viton LM, which met the requirements. Subsequently, stress corrosion of titanium was identified as a problem and extensive inhouse effort was devoted to its solution. The result is two fluorocarbon sealant formulations identified as Viton I and Viton II, based on duPont's LD-487 polymer, which have been characterized and are available as "off the shelf" compounds. This program is being phased out due to reduced Air Force Requirements for sealants with temperature capabilities above 450°F. We plan to flight test the Viton I and dynamic evaluations are continuing.

MILESTONES:

A. Viton I has been fully characterized and a report has been written.

B. Viton II will be fully characterized and a report submitted by 1 January 1975.

C. A basic stress corrosion study is being completed and a report will be submitted by 1 January 1975.

D. Viton I is currently undergoing dynamic evaluation.

E. The entire program will be closed out by 1 January 1975.

REPORTS ISSUED:

Technical Report AFML-TR-72-290 , April 1974, "Hydrofluorocarbon Sealants with Improved Low Temperature and Stress Corrosion Properties."

MATERIALS GENERATED:

A. Viton I - Off the shelf formulation optimized for stress corrosion properties. Has solids content limitations.

B. Viton II - Off the shelf formulation optimized without regard to stress corrosion. Offers higher solids content and better adhesion than Viton I.

Notes:

1. Both of the above sealants can meet the low temperature requirements (-65°F) listed in MIL-S-8802. Previous fluorocarbons were considered deficient in this respect.

2. Viton I is demonstrating outstanding performance in dynamic evaluations. Marginal stress corrosion properties may still restrict its use in titanium aircraft, however.

III. Fluorocarbon/Fluorosilicone Hybrids

A fluorosilicone/fluorocarbon hybrid sealant has been developed by Dow Corning under AFML contract. Inhouse characterization by the AFML shows capability at 500°F, fifty degrees higher than state-of-the-art fluorosilicones, while retaining the other desirable properties of the state-of-the-art fluorosilicones. The base material for this sealant is a hybrid fluorosilicone/fluorocarbon polymer (designated FCS-210) of the unit structure,

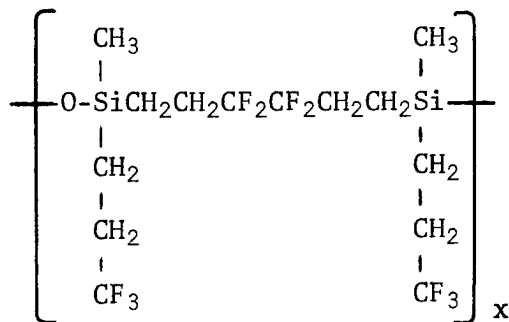

which can be crosslinked using RTV silicone technology. The sealant offers a good balance of properties, retaining the low temperature and handling characteristics of the fluorosilicones, while showing improved high temperature performance imparted by the fluorocarbons. The only disadvantage indicated by the data is that the hybrid has lost 20°F on low temperature flexibility. Recent work, however, indicates that an FCS-210/fluorosilicone copolymer can regain this low temperature flexibility without sacrificing the other advantages of the FCS-210 hybrid polymer. Dynamic evaluation of the FCS-210 sealant has verified its

improved performance at high temperature. Samples of the FCS-210 sealant have been distributed for outside evaluation and the material is ready for flight test.

IV. Dynamic Evaluations

A critical part of the sealant development program is the evaluation of promising materials. Small scale static evaluations are very useful for guiding sealant development efforts and initial screening of candidate sealants by potential users. They do not, however, provide an accurate indication of how the sealant will perform under actual flight conditions in an aircraft where they are exposed to changing environments and loading conditions. A key evaluation, therefore, is the bench scale measurement of dynamic response. For this purpose, a dynamic sealant tester has been designed and fabricated by Dow Corning, under an AFML contract, which is capable of evaluating small samples of sealants under conditions closely simulating those encountered in actual aircraft integral fuel tanks. It is a very versatile device which automatically subjects simulated sealed structural joints to mechanical loading simultaneously to environmental exposures. This unique dynamic test offers both excellent comparison of sealant candidates and opportunity for correlation to flight test data. This can be accomplished by carefully programming the mechanical loading and environmental exposures to represent actual flight profiles of existing aircraft. Preliminary data has been obtained at 500°F with the AFML's fluorocarbon and fluorosilicone hybrid sealants, as well as state-of-the-art fluorosilicone and polyester sealants. The preliminary comparison based on these early data indicates that a direct correlation with performance on advanced aircraft is possible. Although the preliminary data proved the validity of the dynamic test concept, it also exposed some weaknesses in the design and fabrication of the apparatus. Modifications have been drawn up which will greatly enhance the precision and accuracy of the data. Testing has been suspended until the modification of the apparatus has been accomplished.

AFML Polymer Development for Elastomeric Sealant Applications

Dr. Christ Tamborski

Currently the AFML is investigating a number of fluorine containing polymer systems for elastomeric sealant applications. Three polymer systems currently under investigation are the perfluoroalkylether benzoxazole polymers (AFML in-house), perfluoroalkylether-1,2,4-oxadiazole polymers (AFML in-house), and the fluorine containing silicone polymers (Dow-Corning Corp.). Figures 1-5 are concerned with the perfluoroalkylether benzoxazole polymers.

Figure 1 and 2

Preparation of perfluoroalkylether benzoxazole polymers. The type of polymer synthesized, experimental conditions, and inherent viscosity are indicated.

Figure 3

The inherent viscosity, melt transition and glass transition temperatures as a function of polymer structure are shown.

Figure 4

Comparison of the isothermal aging of a perfluoroalkylether benzoxazole with a Viton polymer (see trial 12, figure 3).

Figure 5

Thermogravimetric analysis of a perfluoroalkylether benzoxazole in air and nitrogen (see trial 6, figure 3).

Figure 6

Synthesis of a polyperfluoroalkylether-1,2,4-oxadiazole polymer.

Figure 7

Physical properties of a typical polyperfluoroalkylether-1,2,4-oxadiazole polymer. Hydrolytic and thermal stability data are shown on an unfilled sample.

Figure 8

General structure of a fluorocarbon silicone FCS polymer (Dow-Corning). When $x=2$, the sample is designated FCS 210.

Figure 9

General structure of an experimental copolymer of a methyl-trifluoropropyl silicone (LS) and a fluorocarbon silicone (FCS 210). Materials developed by Dow-Corning Corp. Non-reverting character and wide temperature range stability are indicated in random and alternating copolymer system.

Figure 10

General structure of research fluoroalkylether silicone polymers with improved low-temperature properties (Dow-Corning Corp.) Low-temperature properties due to presence of fluoroalkylether structures.

PROPERTIES OF POLYMERS

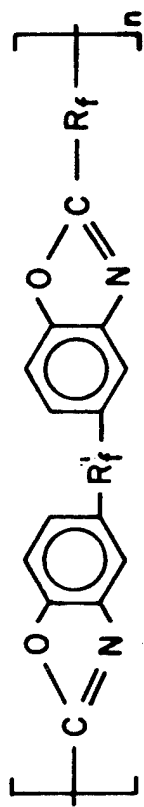

Trial No.	Rf'	Rf	$\eta_{inh}^{(a)}$ dl./g.	$T_m^{(b)}$ °C	$T_g^{(b)}$ °C
3	(CF ₂) ₃	(CF ₂) ₈	0.45	187	106
6	"	CF ₂ O(CF ₂) ₂ OCF ₂	0.94	---	29
7	"	(CF ₂) ₄ O(CF ₂) ₂ OCF ₂	0.51	---	9
8	(CF ₂) ₈	(CF ₂) ₈	0.21	179	---
9	"	CF ₂ O(CF ₂) ₂ OCF ₂	0.30	93	---
10	(CF ₂) ₂ O(CF ₂) ₅ O(CF ₂) ₂	(CF ₂) ₈	0.20	---	-5
12	"	CF ₂ O(CF ₂) ₂ OCF ₂	0.07	---	-22
14	"	"	0.28	---	-16
15	"	"	0.40	---	-15
18	"	(CF ₂) ₄ O(CF ₂) ₂ OCF ₂	0.79	---	-20

(a) 0.2g./dl., 25°C., HFIP

(b) Differential Scanning Calorimetry ($\Delta T = \frac{20^\circ\text{C}}{10 \text{ min}}$)

Fig. 1



Trial No.	R _f '	R _f	Time-Hrs.	Reaction Concentration	η_{inh} dl./g.
10.	(CF ₂) ₂ O(CF ₂) ₅ O(CF ₂) ₂	(CF ₂) ₈	192	3	0.20
11.	"	"	312	7	0.17
12.	"	CF ₂ O(CF ₂) ₂ OCF ₂	192	6	0.07
13.	"	"	216	6	0.07
14.	"	"	192	14	0.28
15.	"	"	192	20	0.40
16.	"	"	264	30	0.28
17.	"	(CF ₂) ₄ O(CF ₂) ₂ OCF ₂	240	30	0.44
18.	"	"	264	20	0.79

(a) $\frac{\text{G. Equivalent} \times 10^4}{10 \text{ ml. HFIP}}$

(b) 0.2 g./dl., 25°C., HFIP.

Fig. 2

PREPARATION OF POLYMERS

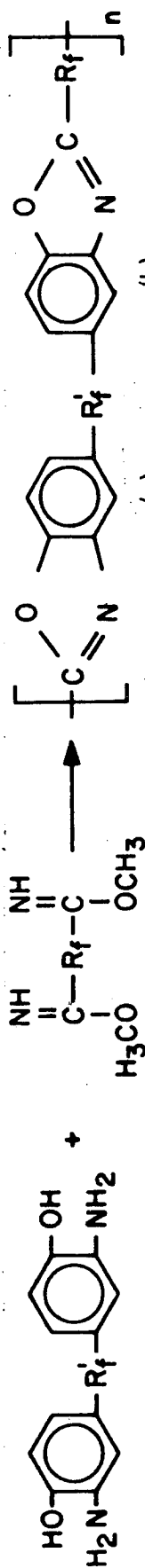

Trial No.	R_f'	R_f	(a)		(b)	
			Time - Hrs.	Reaction Concentration	Time - Hrs.	η_{inh} dl./g.
1.	$(CF_2)_3$	$(CF_2)_8$	24	5	0.10	
2.	"	"	192	5	0.27	
3.	"	"	288	5	0.45	
4.	"	$CF_2O(CF_2)_2OCF_2$	60	6	0.25	
5.	"	"	132	6	0.45	
6.	"	"	240	30	0.94	
7.	"	$(CF_2)_4O(CF_2)_2OCF_2$	312	16	0.51	
8.	$(CF_2)_8$	$(CF_2)_8$	384	2	0.21	
9.	"	$CF_2O(CF_2)_2OCF_2$	384	3	0.30	

(a) $\frac{\text{G. Equivalent} \times 10^4}{10 \text{ ml. HFIP}}$

(b) 0.2 g./dl., 25°C., HFIP.

Fig. 3

ISOTHERMAL AGING IN AIR AT 316°C.

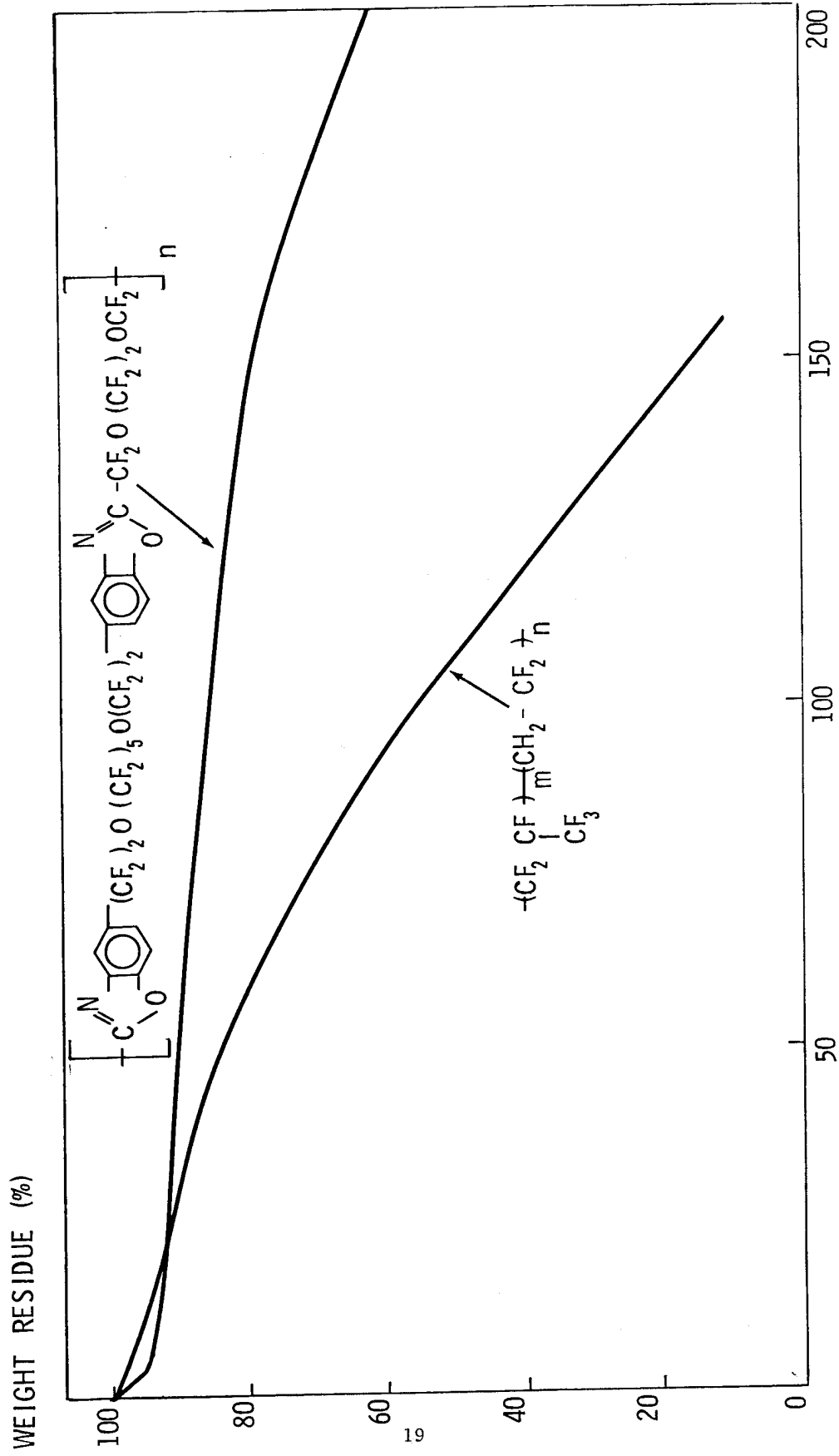

Fig. 4

TIME (hours)

WEIGHT RESIDUE (%)

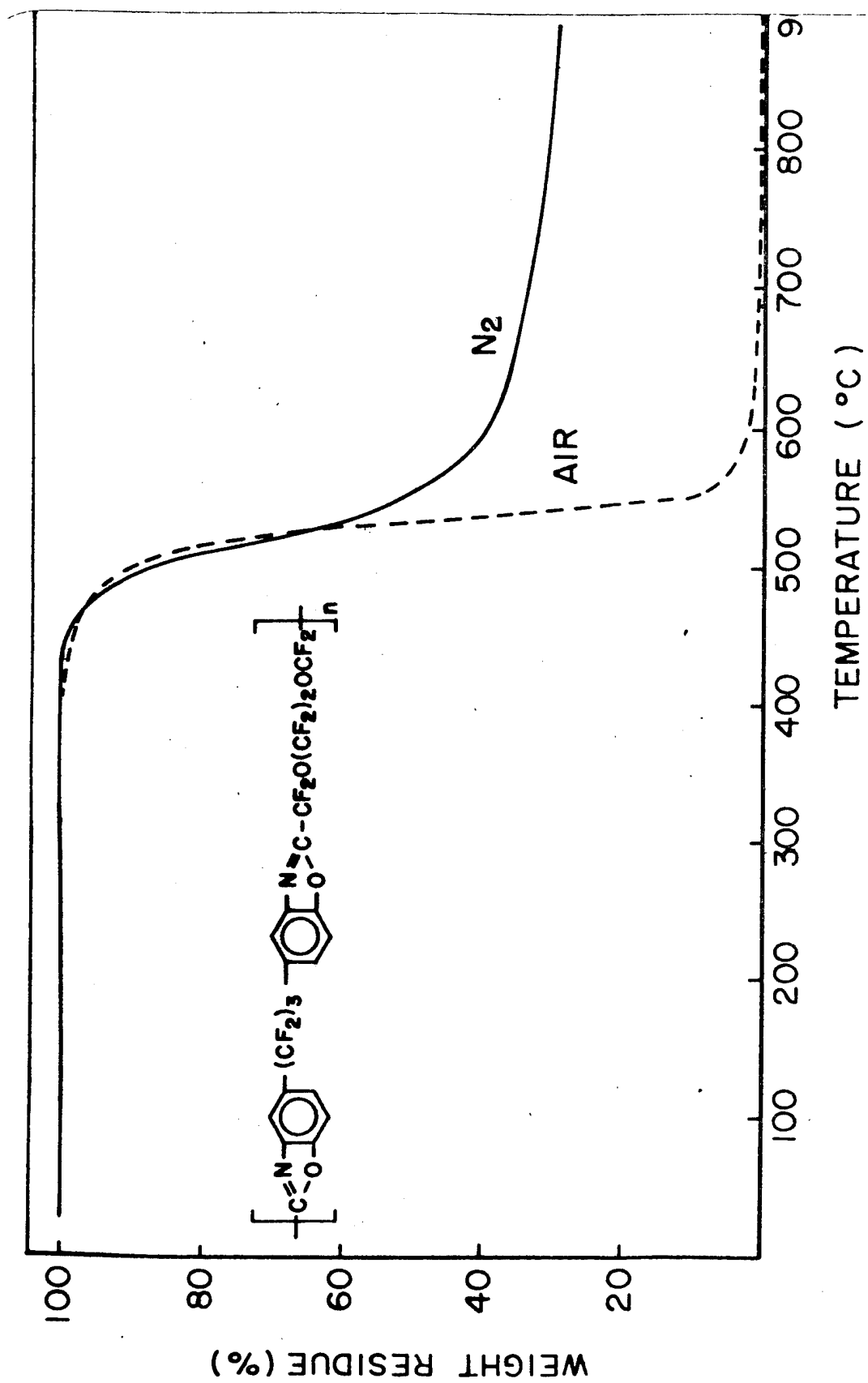
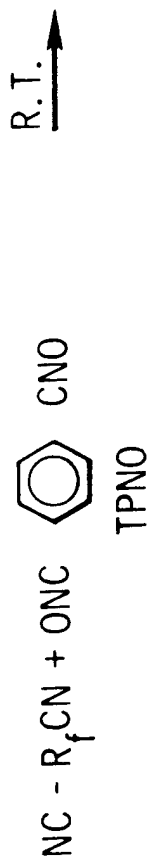
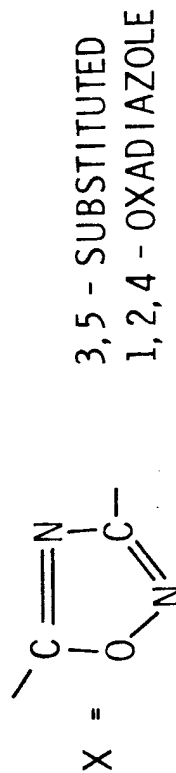

Fig. 5

POLYOXADIAZOLE SYNTHESIS



R_f = POLY(PERFLUOROETHYLENE OXIDE)



A SMALL AMOUNT OF A THIRD MONOMER IS ADDED TO THE REACTION MIXTURE TO PROVIDE CROSS-LINKING SITES.

POLYOXADIAZOLE EVALUATION

PHYSICAL PROPERTIES:

	<u>UNFILLED</u>	<u>20% (w/w) HiSiL-EP FILLED</u>
TENSILE STRENGTH, PSI	1455	2200
ELONGATION @ BREAK, %	560	595
HARDNESS, SHORE A	45-50	70
TR-10, °F	-73	
T _G , °F, ON GUM	-83	

HYDROLYTIC STABILITY, 60 DAYS @ 165°F, 100% RH --

TENSILE STRENGTH DOWN 18%

ELONGATION DOWN 6%

THERMAL STABILITY, 60 DAYS IN AIR @ 400°F --

TENSILE STRENGTH DOWN 66%

ELONGATION DOWN 68%

CUMULATIVE EST. LOSS 5.66%

USE - POTENTIAL -65°F TO +400°F SEAL MATERIAL.

Fig. 7

SECOND GENERATION: LOW SWELL SILICONE

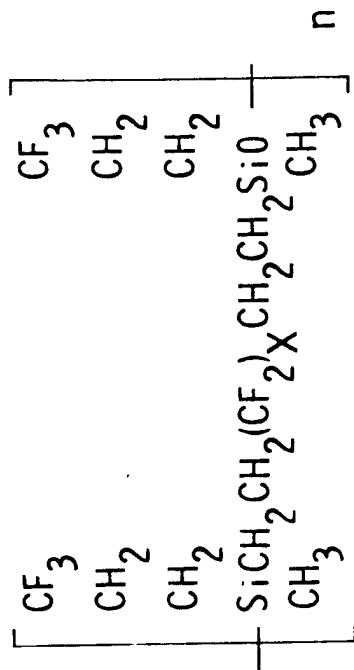

"FCS"

-25° F → 500° F ; X = 2

FUEL AND SOLVENT RESISTANCE

REVERSION RESISTANCE

RTV

Fig. 8

THIRD GENERATION:

OBJECTIVE: DEMONSTRATE THE UTILITY AND OPTIMIZE THE COMPOSITION OF LS/FCS COPOLYMERS FOR USE AS HIGH TEMPERATURE SEALANTS.

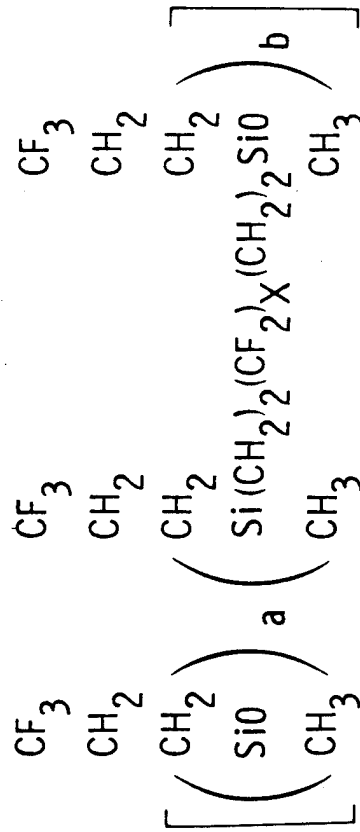

LS/FCS COPOLYMERS

X = 2

RANDOM	1:1	-36° F to 500° F	NONREVERTING
BLOCK	1:1	-58° F to 450° F	REVERTING
ALTERNATING	1:1.5	-40° F to 500° F	NONREVERTING

Fig. 9



FES 32-10

Tg -56°F
N = 10 \rightarrow 12

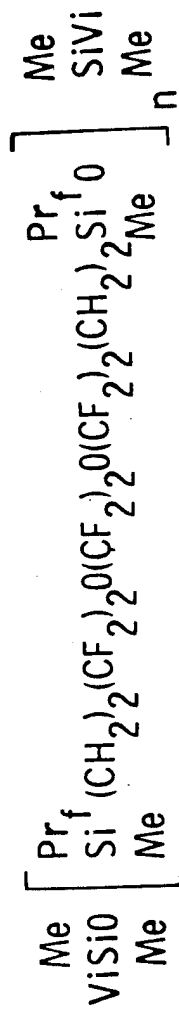

FES-222-10

Tg -40°F
N = 10 \rightarrow 12



FES 252-10

Tg -62°F
N = 10 \rightarrow 12

Fig. 10

Characterization and Degradation Studies of Sealants Candidates

by

Ming-ta Hsu

The microstructure of several high temperature sealant elastomers was studied by nuclear magnetic resonance (NMR) and infrared (IR) spectroscopy. Thermal and hydrolytic stability of sealants candidates have also been studied and their structural changes occurring during thermal and hydrolytic degradation have been examined. The purpose of this study is to determine which of the candidates is the best fuel tank sealant and whether an improved sealant is needed.

Three candidate sealant materials have been investigated. They are cyanosiloxane, fluorosilicone (DC-77-028) and fluorosilicone - fluorocarbon hybrid (DC-77108) polymers. The cyanosiloxane polymer was synthesized by Product Research Corporation and the fluorosilicone and the hybrid polymers were synthesized by Dow Corning Company.

The structure of these three polymers were studied by NMR and IR techniques. The first figure shows the NMR spectrum and IR bands of cyanosiloxane polymer. There are five different proton types. From the chemical shift of the protons we know that they are CH_3 attached to a Si; CH_2 attached to a Si; OH group; CH_2 adjacent to two CH_2 groups and CH_2 attached to a CN group. The IR shows CH; CN; Si- CH_3 ; Si- CH_2 ; OH and Si-O-Si absorption bands. The structure of the cyanosiloxane polymer is shown in figure 1. From the integral of Si- CH_2 and Si- CH_3 the ratio of m to n was found to be 3 to 2. The NMR, IR and structural changes after thermal and hydrolytic degradation of cyanosiloxane will be shown later. Figure 2 shows the IR and NMR spectra and the structure of fluorosilicone polymer. The NMR spectrum shows three different proton types (Si- CH_3 ; Si- CH_2 and CH_2CF_3) and one type of fluorine (CF_3). The terminal group of $\text{Si}(\text{CH}_3)_3$ shows a small sharp peak at a higher field. There are about 2% vinyl groups present in the polymer as a cross-link site to react with the curing agent. The vinyl group can be detected by NMR and is not shown in the figure. The IR shows CH; Si CH_2 ; Si CH_3 ; Si-O-Si and CF_3 bands. The IR and NMR of fluorosilicone-fluorocarbon hybrid polymer are shown in Figure 3. The proton NMR spectrum is similar to that of fluorosilicone except that the ratio of Si CH_2 to Si CH_3 is 4 to 3. The ^{19}F NMR shows an extra peak at -114.7 ppm which is the chemical shift of the CF_2 group. The IR spectrum of the hybrid is similar to that of fluorosilicone, except the intensity of the Si-O-Si band

(2)

of the hybrid is weaker and shows an extra CF_2 band. The hybrid also contains about 5% vinyl groups.

Thermogravimetric analysis plots of these elastomers in nitrogen are shown in Figure 4. We can see that fluorosilicone is the most stable polymer and the cyanosiloxane is the least stable polymer. Cyanosiloxane starts to degrade at 250°C and gradually loses weight yielding a white residue about 40% of its original weight. The white residue is believed to be silicon dioxide and it should be noted that the percentage of SiO_2 theoretically possible from cyanosiloxane polymer is 40%. Fluorosilicone and the hybrid will also give some SiO_2 residue. Chain scission and depolymerization of the polymers occurred during thermal degradation. The volatile materials were not studied the microstructure of the thermal degradation residue of the three polymers at different weight losses were examined. The solubility of the 20% weight loss material from the cyanosiloxane polymer decreased and the NMR showed a decrease in the OH peak. A new small C=N band was found in the IR and we believe that Si-OH and CN groups are the sites for crosslinking during the thermal degradation. Cyanosiloxane polymer is not a hydrolytically stable material. For example, when boiling this polymer with kerosine in the presence of small amounts of acid or base, the texture of the polymer changed and the IR indicated a decrease in the CN band with formation of a carboxyl band. Apparently the CN group was rapidly hydrolyzed to the carboxyl group and from this evidence it is concluded that cyanosiloxane is not a good sealant polymer candidate.

The IR spectra of thermally degraded residue at 10-30% weight loss of both fluorosilicone and the hybrid indicate no apparent changes. The NMR spectra at 10% weight loss of both polymers show a disappearance of the vinyl group peaks and the terminal group of the fluorosilicone. The molecular weight distribution of the fluorosilicone studied by GPC also changed. The solubility of the hybrid decreased and its viscosity changed from a viscous liquid to a solid at 24% weight loss. Random chain scission with depolymerization accompanied by crosslinking appears to be the mode of thermal degradation in the fluorosilicone polymers.

It is well known that siloxane polymers will undergo reversion to tetramers at higher temperatures. The theory behind the hybrid synthesis is to reduce the reversion rate by

(3)

introducing the fluorocarbon chain between silicon atoms. It is true that the reversion rate of the hybrid is reduced. When fluorosilicone and the hybrid were heated at 250°C for 48 hours in a sealed tube under vacuum, tetramer was found in the fluorosilicone studied by GPC but no small molecules were found for the hybrid. The decrease in the solubility of the hybrid indicated that crosslinking occurred with the vinyl group under these conditions since the NMR showed a disappearance of the vinyl peaks.

A summary of the thermal properties of the three candidates are shown in Figure 5. The Tg of the hybrid is quite high. The activation energy of the hybrid is lower than the fluorosilicone polymer, but the fluorosilicone polymer undergoes reversion slowly even at 250°C. We believe improvements in the area of polymers for fuel tank sealant applications are still needed.

CYANOSILOXANE POLYMER

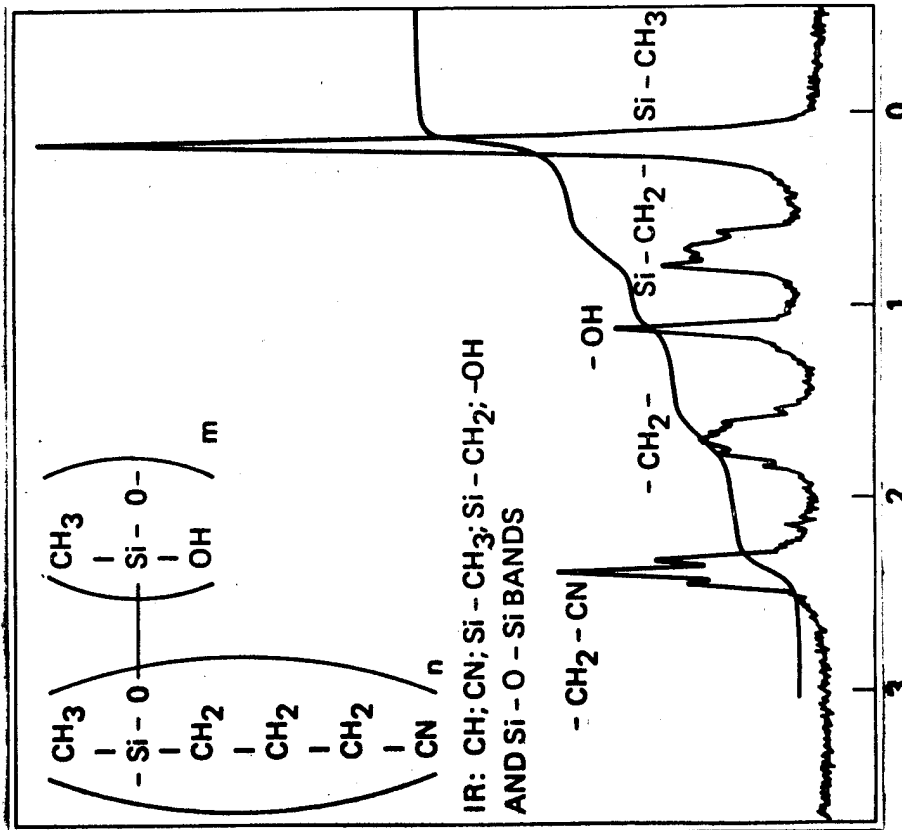

HSU - 1

Fig. 1

FLUROSILICONE POLYMER

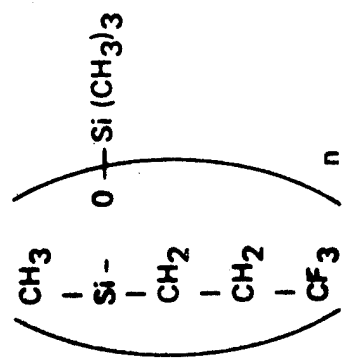

IR: C - H; Si - CH₂; Si - CH₃; Si - O - Si
AND - CF₃ BANDS

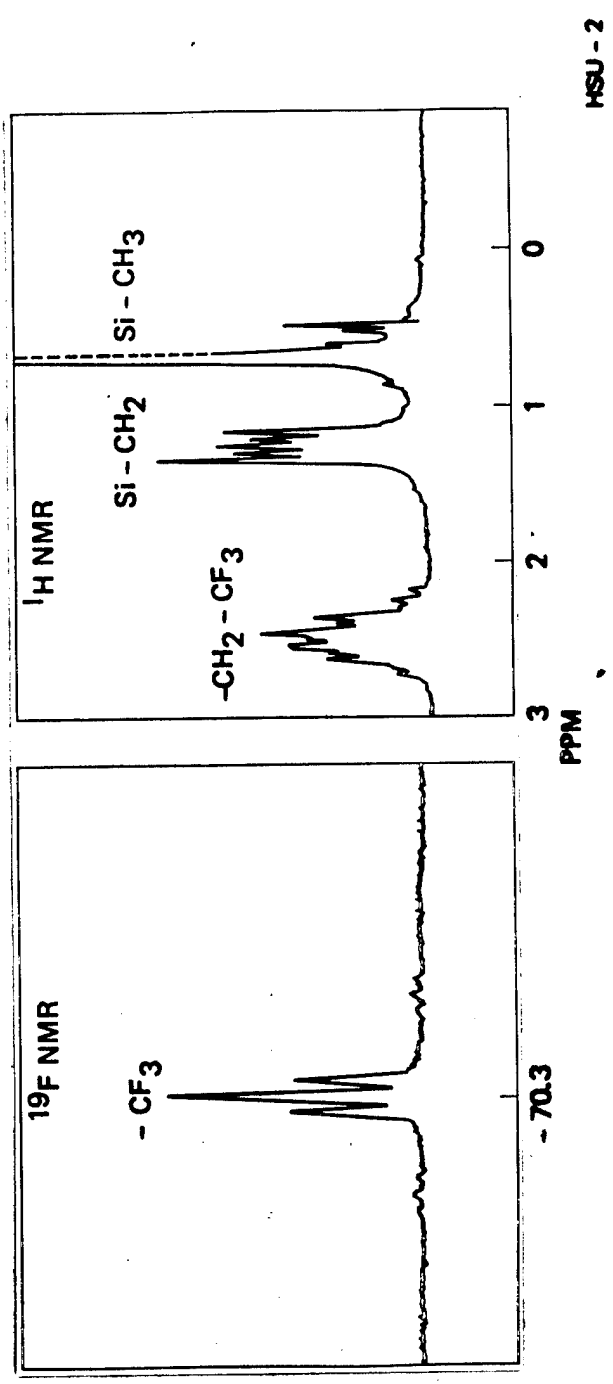
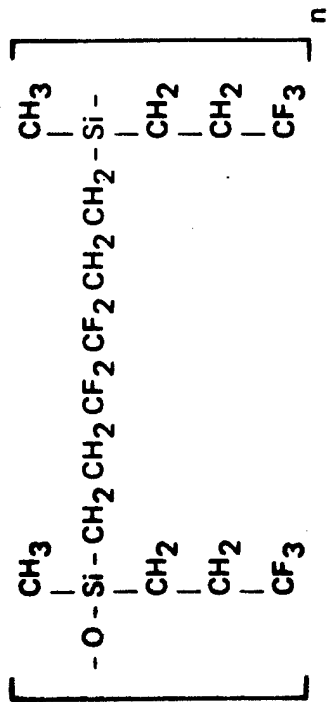

Fig. 2

FLUOROSILICONE - FLUOROCARBON HYBRID POLYMER



IR: C - H; Si - CH₂; Si - CH₃; Si - O - Si; - CF₃
AND CF₂ BANDS

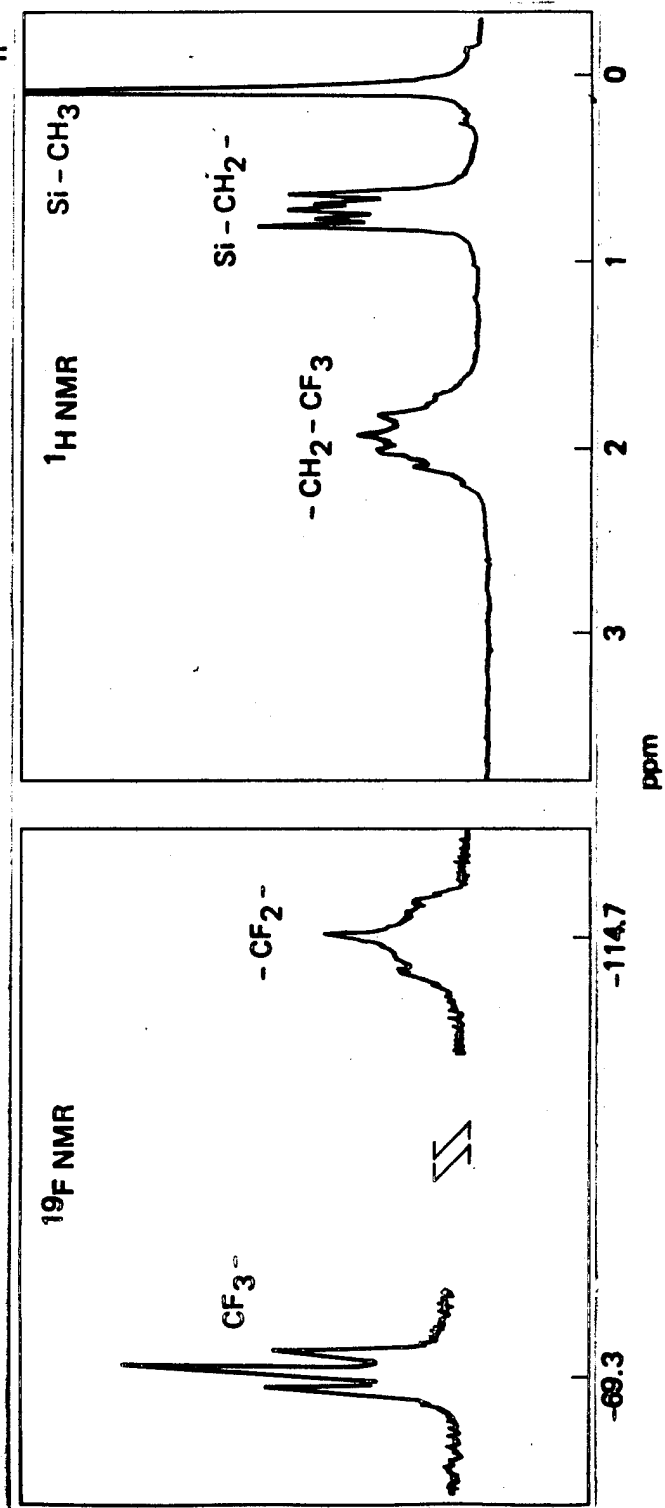

Fig. 3

**THERMOGRAVIMETRIC ANALYSIS OF THE THREE
CANDIDATE SEALANT MATERIALS IN NITROGEN**

- CYANOSILOXANE
- - - FLUOROSILICONE
- - - FLUOROSILICONE-
FLUOROCARBON HYBRID

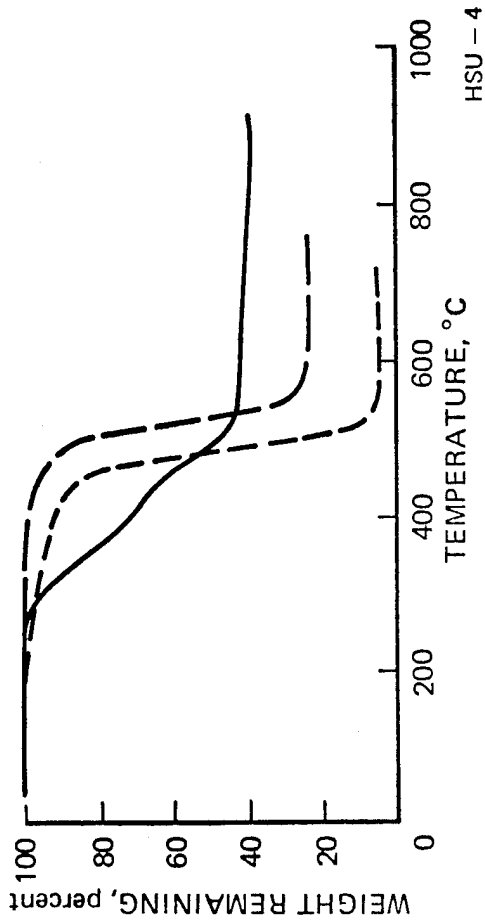

Fig.4

HSU - 4

THERMAL DEGRADATION OF SEALANTS CANDIDATES

MATERIAL	T _g °C	ACTIVATION ENERGY	HEATING CONDITION	RESULT
FLUOROSILICONE (FS)		55 kcal/mole IN NITROGEN	360°C IN NITROGEN FOR 164 min	10% WEIGHT LOSS
UNCURED UNFILLED BASE	-70	33 kcal/mole IN AIR	250° IN A SEALED TUBE UNDER VACUUM FOR 48 hrs	TETRAMER WAS FOUND BY GPC
			TGA STOP AT 10% WEIGHT LOSS	NO APPARENT IR CHANGE TERMINAL AND THE 2% VINYL PEAKS DISAPPEARED IN NMR
FLUOROSILICONE - FLUOROCARBON (FS-FC) HYBRID	-35	43 kcal/mole IN NITROGEN	360° IN NITROGEN FOR 107 min	12% WEIGHT LOSS
			250° IN A SEALED TUBE UNDER VACUUM FOR 48 hrs	NO SMALL SIZE MOLECULES WAS FOUND BY GPC. SOLUBILITY DECREASED.
UNCURED UNFILLED BASE		24 kcal/mole IN AIR	TGA STOP AT 14% WEIGHT LOSS	NO APPARENT NMR, IR CHANGE EXCEPT THE 5% VINYL PEAK DISAPPEARED IN NMR. SOLUBILITY DECREASED.
			FS CURED AND FILLED	300° IN AIR FOR 184 min
FS-FC HYBRID CURED AND FILLED	-28	-	300° IN AIR FOR 113 min	10% WEIGHT LOSS
CYANOSILOXANE UNCURED	-50	-	TGA STOP AT 20% WEIGHT LOSS	OH PEAK DECREASED IN NMR. SOLUBILITY DECREASED. SMALL OH BAND WAS FOUND IN IR

FUNCTIONAL TESTING OF FUEL TANK SEALANT
FOR SUPERSONIC AIRPLANES
AND
ADHESION STUDIES

Page 1. Introduction

Existing test methods for fuel tank sealants are devised to measure sealant properties and resistance to expected fuel tank environments. Although they are useful screening tools and can eliminate unsatisfactory materials, they are not suitable for estimating service life. The test methods customarily involve exposing physical property test specimens to various static environments as well as to cycling changes in temperature, pressure, fuel and fuel vapor, and judging resistance on the basis of property changes. Also, functional tests are performed using sealed joints exposed similarly, loaded structurally and tested for leaks. Loads and cycling environment are not imposed simultaneously and the functional test specimens are normally too large to respond to changes at a rate simulating a flight profile. Testing of large sealed tanks has revealed effects on sealant fillets not experienced with test specimens:

2. So in November of 1972, Boeing entered into a contract with NASA-Ames to design and fabricate a small test tank that would duplicate the materials and construction representative of a Mach 2.7 SST fuel cell; to modify an existing flight cycle chamber to accommodate the tank; fit the tank with actuators to induce cycling loads during cycling environment; and put the system into operation.

Physical property specimens and specimens for a JPL study were suspended in the tank and one test was conducted at the completion of the contract in March 1974. Two hundred and five cycles had been imposed. The JPL specimens were also exposed to an accelerated cycle.

3. The tank is shown here attached to the cover of the flight cycle chamber. It is made of 6 Al-4V titanium. The two hydraulic actuators load the test area which is the lower right hand corner.
4. The tank is shown here being lowered into the flight cycle chamber.

5. This is a sketch of the test area of the tank showing the location of the faying surface (DC 77-053), injection (DC 77-066) and fillet (DC 77-028) seals. The injected sealant is covered by a fillet. Of course the entire tank is sealed as well.

6. The flight cycle is one most representative of the average expected by a fleet of SST's in 1990. It was developed during the period of the U.S. SST program.

The accelerated cycle shown is part of another program. It is shown here because JPL specimens are being exposed to it.

7. Loads tabulated here are imposed at the time and in the number and magnitude shown. They may be more severe than would be experienced in most actual SST fuel tanks but the tank structure can safely endure it.

8. In May of 1974, the contract was renewed with the addition of adhesion studies and possible flight tests of the DC 77-028 sealant in a YF12A. From other programs we concluded that inconsistent and unpredictable adhesion of DC 77-028 to titanium is its most serious deficiency and deserving of more attention.

9. The recognized factors affecting adhesion are catalyst ratio, cure, primer and application of the primer. They are not independent variables. This chart shown the combinations of factors that we are investigating.

There has also been suspicion that titanium substrates inhibit cure. This is being studied using hardness of the cured sealant as the criterion.

9A. Adhesion tests are made using a lap shear specimen of this configuration. Tests will be conducted initially (no exposure) after 6 weeks of accelerated cycling and after a period of accelerated cycling to be decided later in the program. The failed specimens will be examined closely to compare the degree of adhesive failure versus cohesive failure.

And now for the results to date:

10. After 205 flight cycles there were no visible changes to the sealant in the tank. After 302 cycles splits were noticed in 2 locations. One was in the test area where the fillet covers the injection seal. Expansion of the injection sealant probably caused rupturing of the fillet. It was not unexpected.

11. The other split was not in the test area. It was adjacent to the load block that transfers loads into the tank structure.

The tank is leak free despite the splits.

12. This table is of the results of the tests of specimens suspended in the tank. There were 10 per point for tensile, 5 per point for hardness and 4 per point for weight and volume change. In such a short time of exposure changes were not expected to be great and at 205 cycles they were not except for weight and volume change. We searched for, but could not determine a reasonable explanation for this, so a second set of specimens was prepared and exposed. Results were more as expected.

13. The JPL specimens from the accelerated cycle were submitted monthly for 14 months.

Specimens from the flight cycle were submitted after 4 different periods.

The results will be reported by JPL.

14. Not enough data have been developed to draw concrete conclusions from the adhesion studies. These hardness tests of aluminum vs. titanium substrate were made on slabs of sealant applied without primer to cleaned aluminum and titanium substrates. Hardness was measured on the side that had been next to the metal. Results also served to indicate effects of catalyst ratio on cure. This curve is of specimens made using a 14 day room temperature cure. Apparently the prescribed 10 pph catalyst to base ratio is optimum with the system more forgiving if the amount of catalyst is on the low side rather than the high side. The cure may be inhibited by titanium.

15. This curve represents effects using 24 hours of 160⁰F cure with similar results.

16. Use of 24 hours of 160⁰F plus 1 hour of 300⁰F cure also indicate the same.

17. Results from 1 set of lap shear specimens using the 24 hours of 160⁰F followed by 1 hour of 300⁰F cure again indicate that 10 pph catalyst is optimum. There is no significant difference between air cure and heat cure of the primer, but there was much more data scatter when a heat cure was used.

18. It is too early in the program to draw many definite conclusions since only a few combination of factors have been investigated. However, there are consistent indications that 10 pph catalyst to base ratio is optimum and, at least with one combination of factors, cure appears to be inhibited by the presence of titanium.

NAS2-7341

FUNCTIONAL TESTING OF FUEL TANK SEALANT
FOR SUPERSONIC AIRPLANES
AND
ADHESION STUDIES

Fig. 1

July 25, 26, 1974

BACKGROUND

TANK TEST INITIATED IN NOVEMBER OF 1972 AND CONTINUED
TO MARCH, 1974

- o TANK WAS DESIGNED AND FABRICATED
- o FLIGHT CYCLE CHAMBER WAS MODIFIED TO
ACCOMMODATE IT
- o PHYSICAL TEST SPECIMENS AND JPL STRESS
RELAXATION SPECIMENS WERE EXPOSED WITH THE TANK
- o ONE TEST WAS CONDUCTED AFTER 205 HRS OF 426-441 °F
FUEL VAPOR EXPOSURE
- o JPL SPECIMENS WERE ALSO EXPOSED TO AN ACCELERATED
CYCLE

Fig. 2

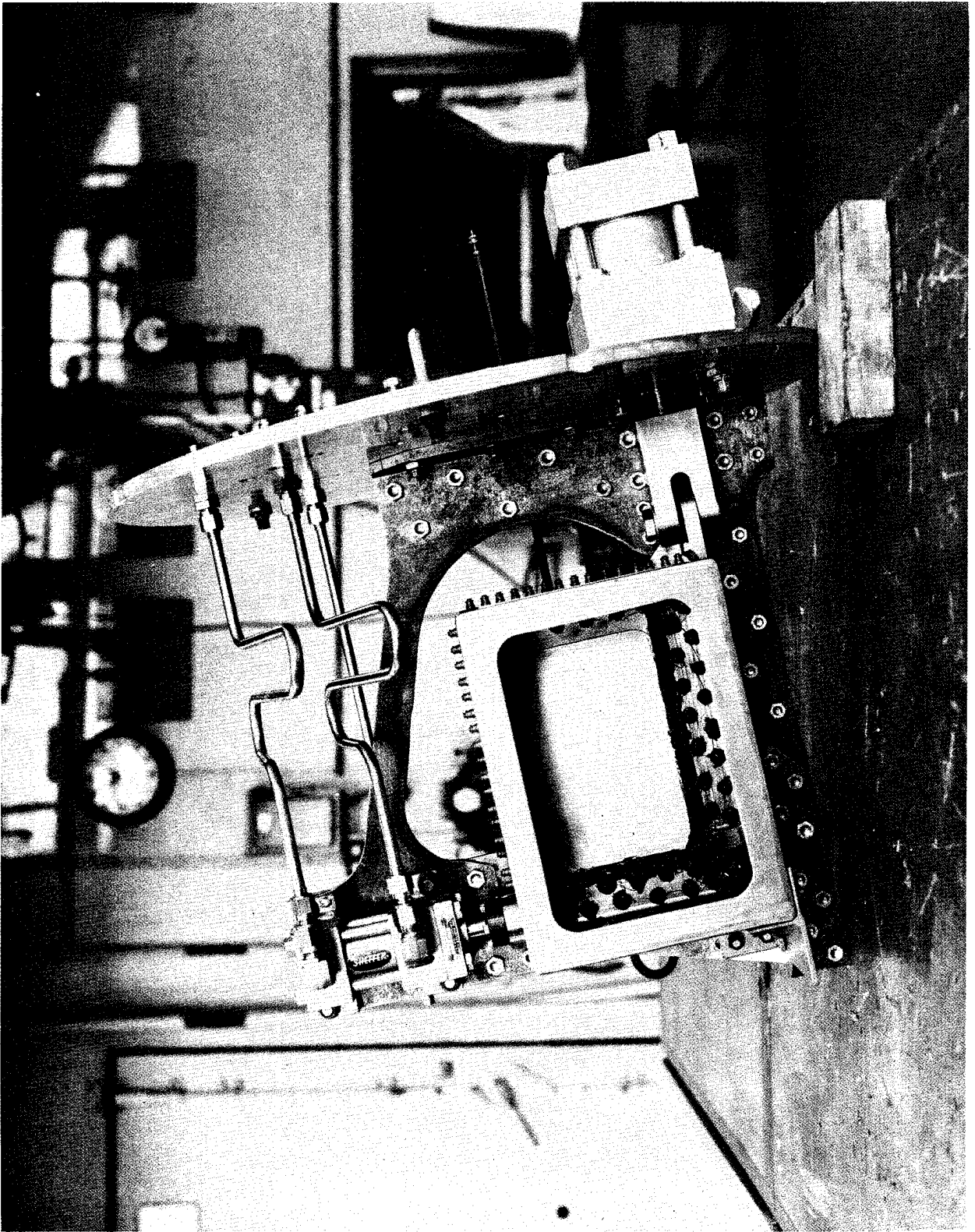

Fig. 3 - Small tank and actuator assembly

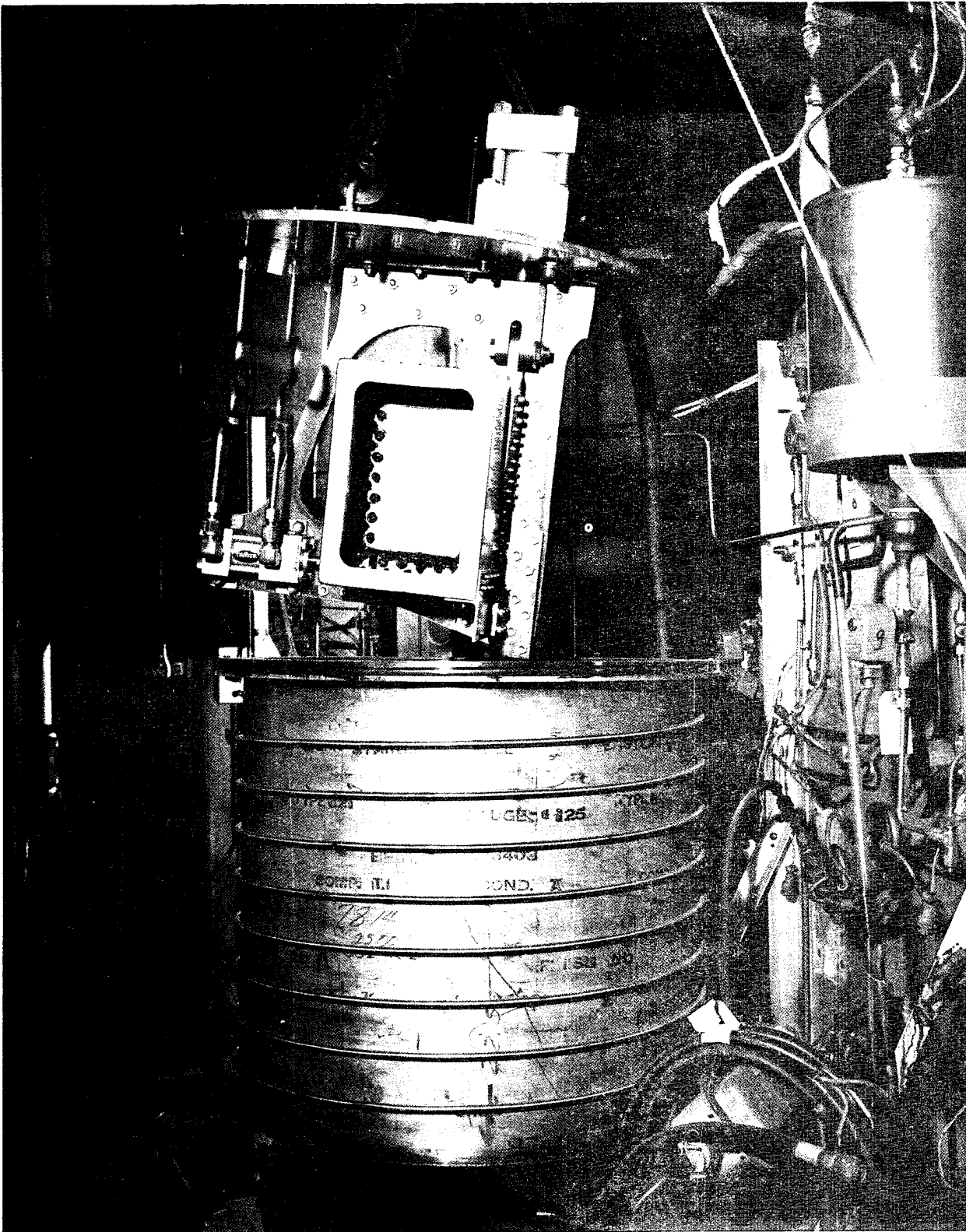

Fig. 4 - Small tank and actuator assembly and flight cycle chamber

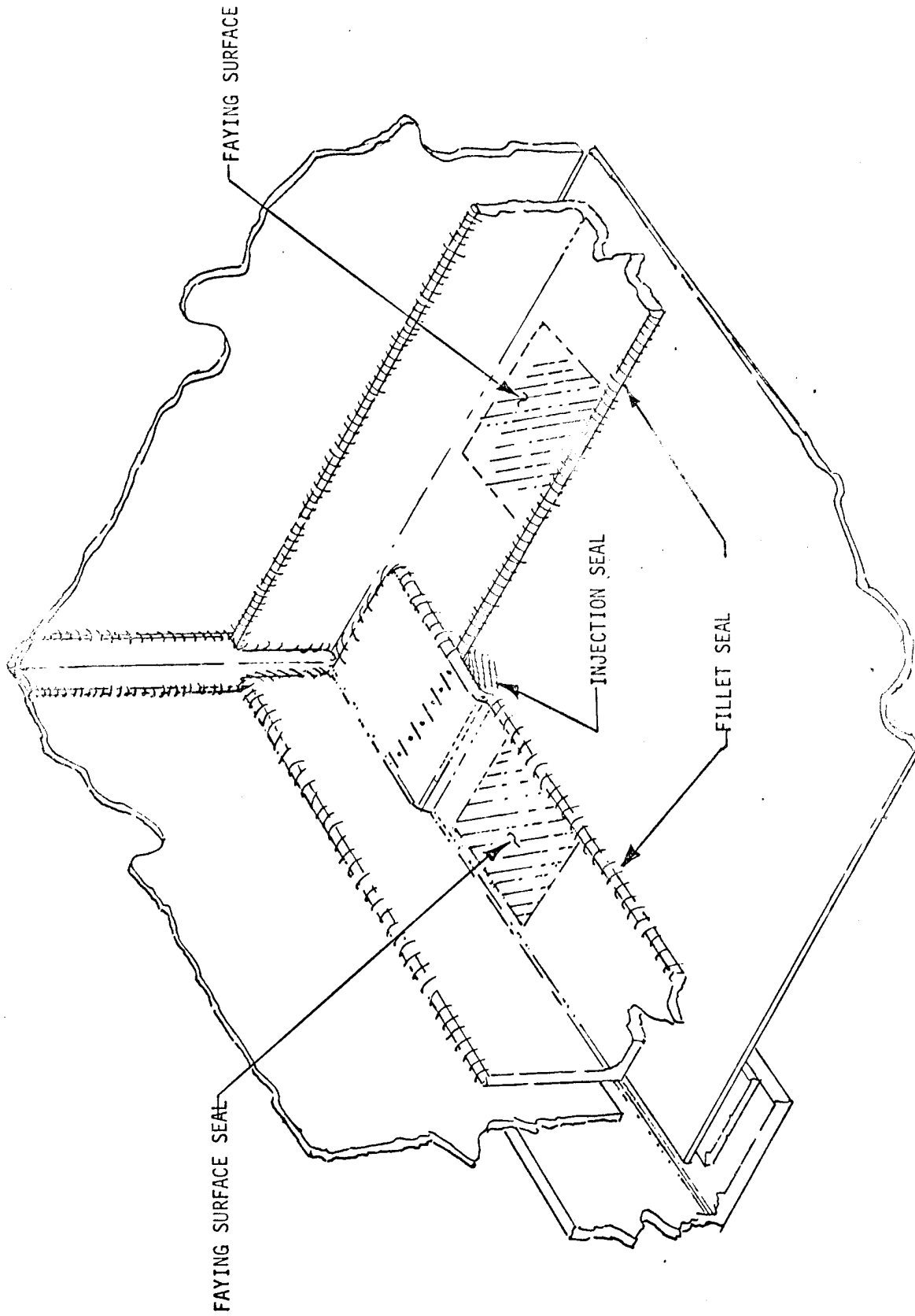
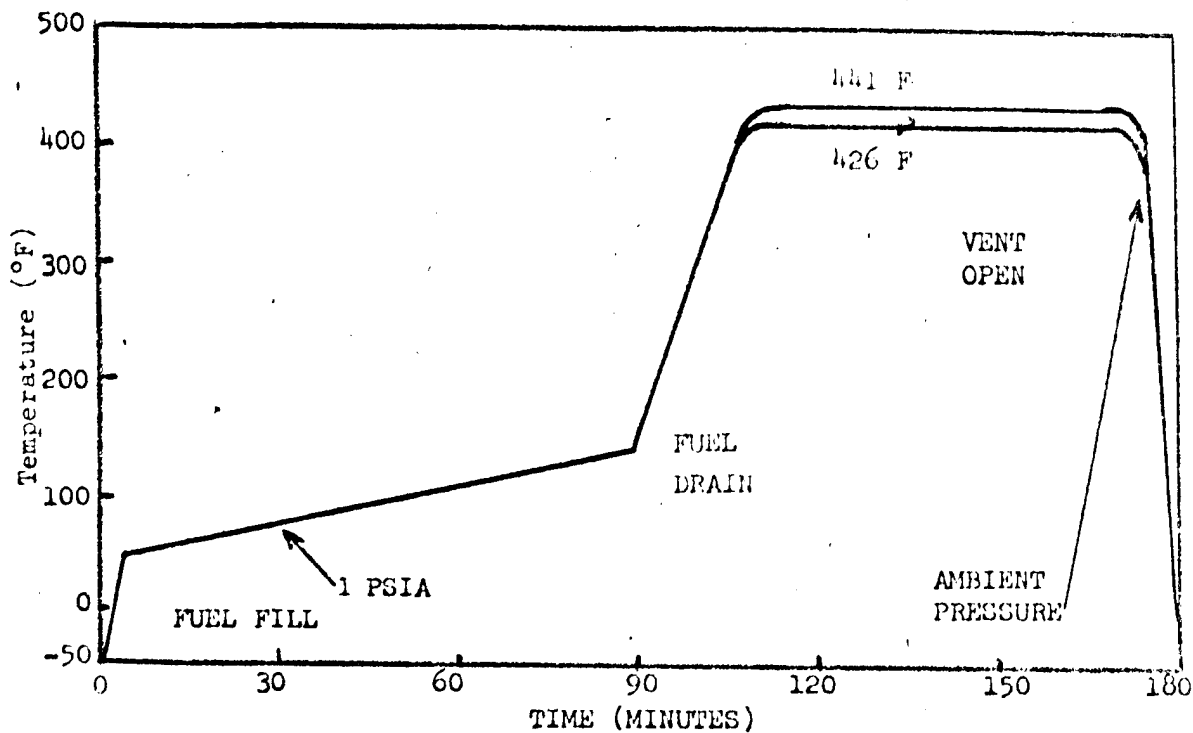

Fig. 5 - Test area

STANDARD FLIGHT CYCLE



ACCELERATED EXPOSURE CYCLE

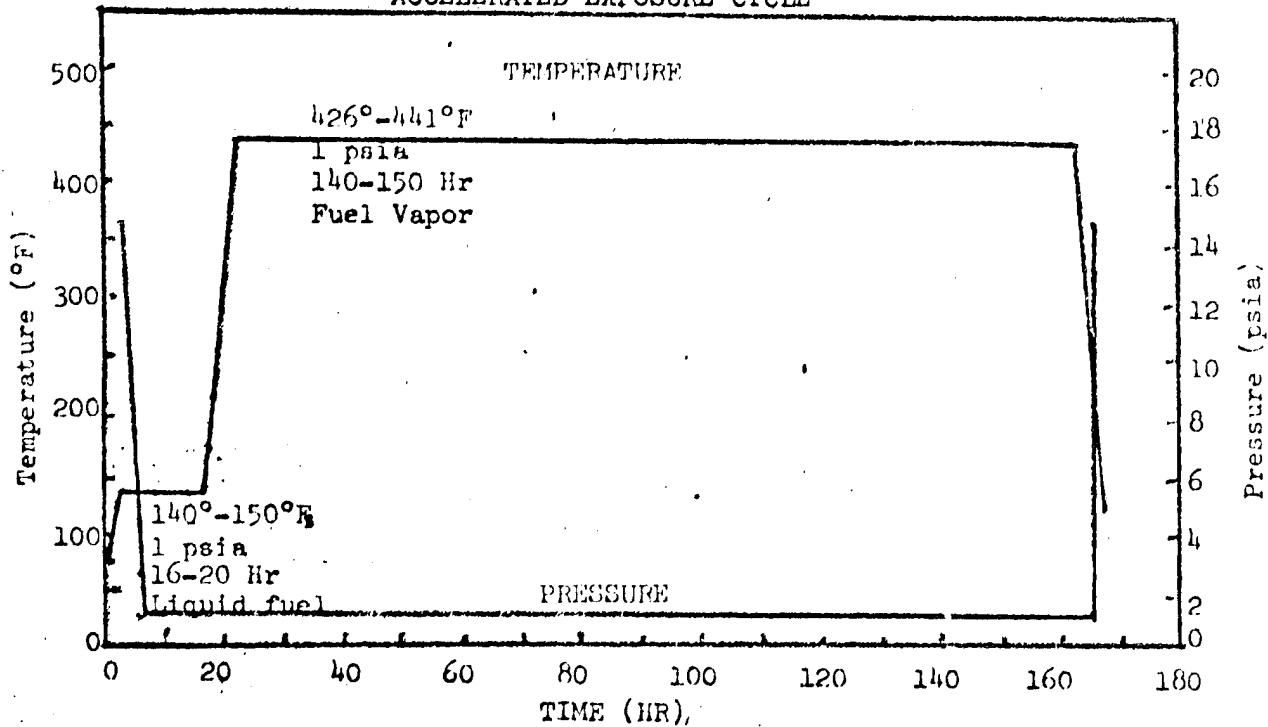

Fig. 6

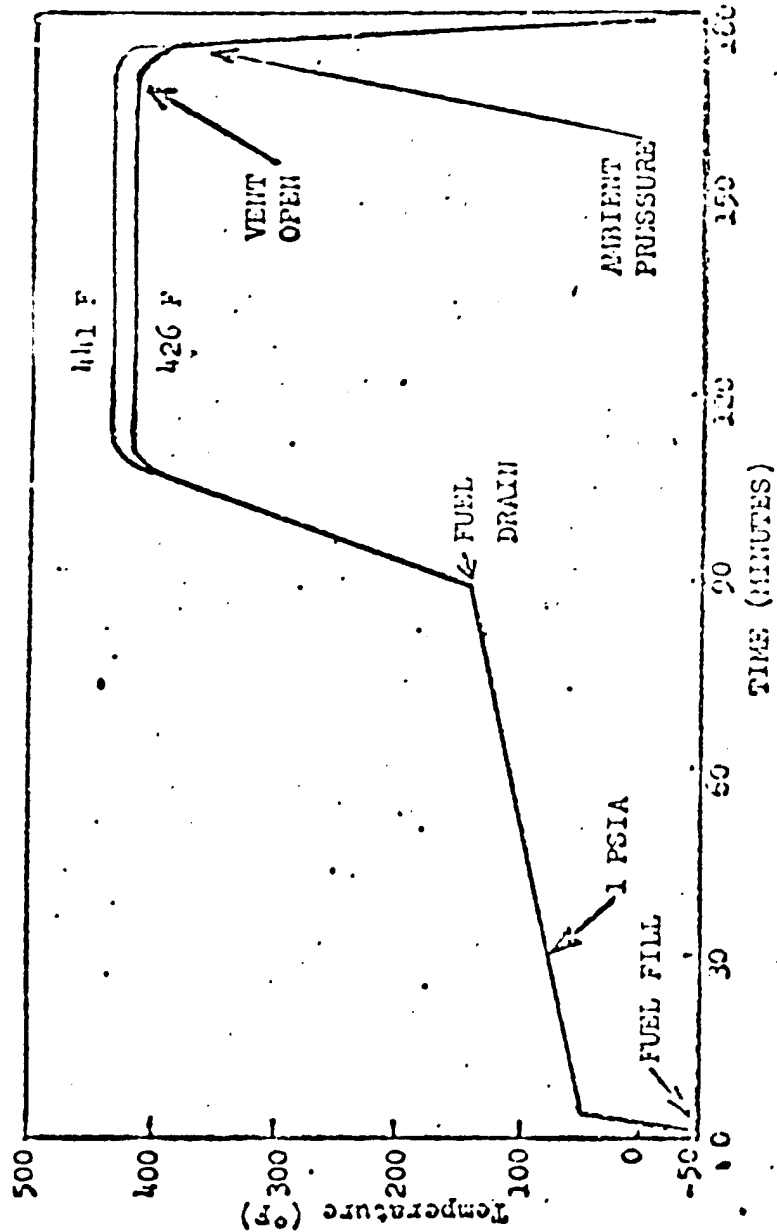

Fig. 7 - Standard flight cycle

FLIGHT CYCLE TEMP. °F	NO OF LOAD CYCLES	MAGNITUDE OF LOAD, LBS. SPAINWISE	CROSSWISE
-50	20	+ 16,600	+ 1400
		- 6,300	
-50 to +441	10	+ 16,600	+ 1400
		- 6,300	
441	10	+ 8,300	+ 700
		- 3,100	

CONTRACT RENEWED IN MAY, 1974

TO CONTINUE TEST, POSSIBLY COOPERATE IN
SEALING SOME BAYS OF YF12-A AND INVESTIGATE
FACTORS AFFECTING ADHESION.

Fig. 8

THE **BOEING** COMPANY
SEATTLE, WASHINGTON

ADHESION STUDIES

DC 77-028 (DC 94-529) ONLY

VARIED FACTORS

<u>CATALYST RATIO</u>	<u>CURE</u>	<u>PRIMER</u>	<u>PRIMER TREATMENT</u>
5 PPH	14 DAYS R.T.	DC 1200	AIR DRY 90 MIN.
10	24 HRS. 160°F	DC 77-123	AIR DRY 90 MIN. +
12	24 HRS. 160°F +	X3-6061	1 HR 300°F
15	1 HR 300°F		

ALUMINUM VERSUS TITANIUM SUBSTRATE

Fig. 9

pulled at a head travel of one-inch per minute.

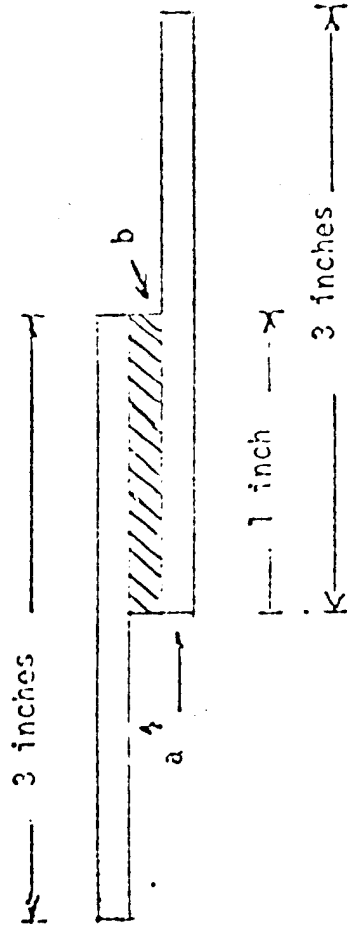

a = 6Al-4V titanium panel (.05 inch thick)

b = sealant (.017 inch thick)

Fig. 9a



Fig. 10.

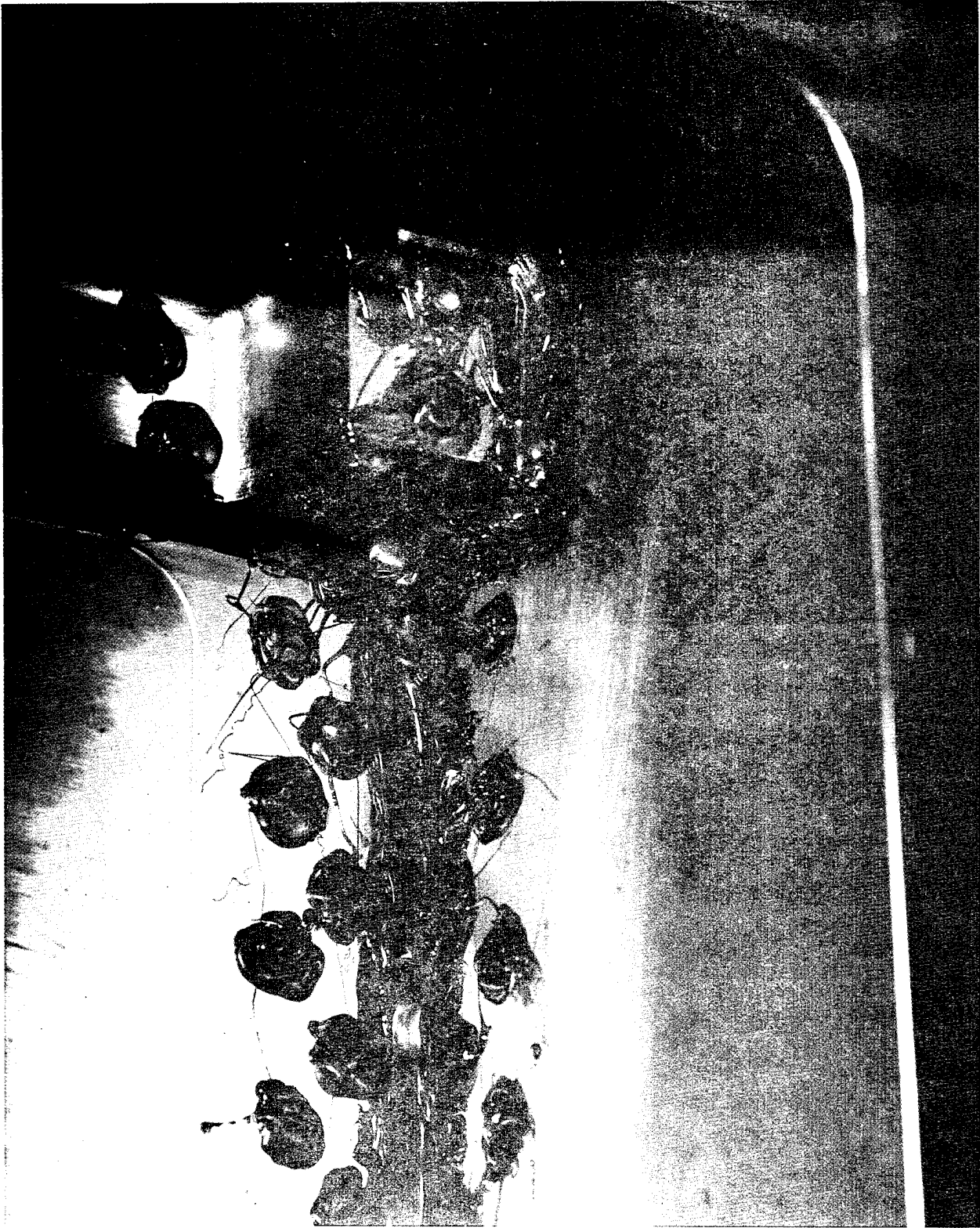

Fig. 11

PROPERTIES OF LOT EAEK 122001 OF DC 77-028

	FLIGHT CYCLE			
	1ST SET		2ND SET	
	INITIAL	205 CYCLES*	60 CYCLES	97 CYCLES
HARDNESS, SHORE A	38	49	40	39
TENSILE STRENGTH AT R.T.	673 psi	755 psi	666 psi	614 psi
TENSILE STRENGTH AT -50°F	1506 psi	1718 psi	1665 psi	1559 psi
TENSILE STRENGTH AT +450°F	148 psi	131 psi	128 psi	92 psi
TENSILE ELONGATION AT R.T.	210%	119%	191%	198%
TENSILE ELONGATION AT -50°F	299%	190%	287%	274%
TENSILE ELONGATION AT +450°F	49%	28%	38%	32%
VOLUME CHANGE		-10%	+1.5%	+1.7%
WEIGHT CHANGE		-8.8%	+ .4%	+1.9%

* THE VOLUME LOSS, WEIGHT LOSS AND HARDNESS CHANGE ARE SURPRISINGLY HIGH FOR THIS RELATIVE SHORT TIME EXPOSURE.

Fig. 12

JPL SPECIMENS

ACCELERATED CYCLE

14 MONTHS. UP TO 8,030 HOURS OF 426-441°F
FUEL VAPOR EXPOSURE.

FLIGHT CYCLE

SPECIMENS SUBMITTED AFTER 60, 97, 205 AND
302 CYCLES

Fig. 13

THE **BOEING** COMPANY
SEATTLE, WASHINGTON

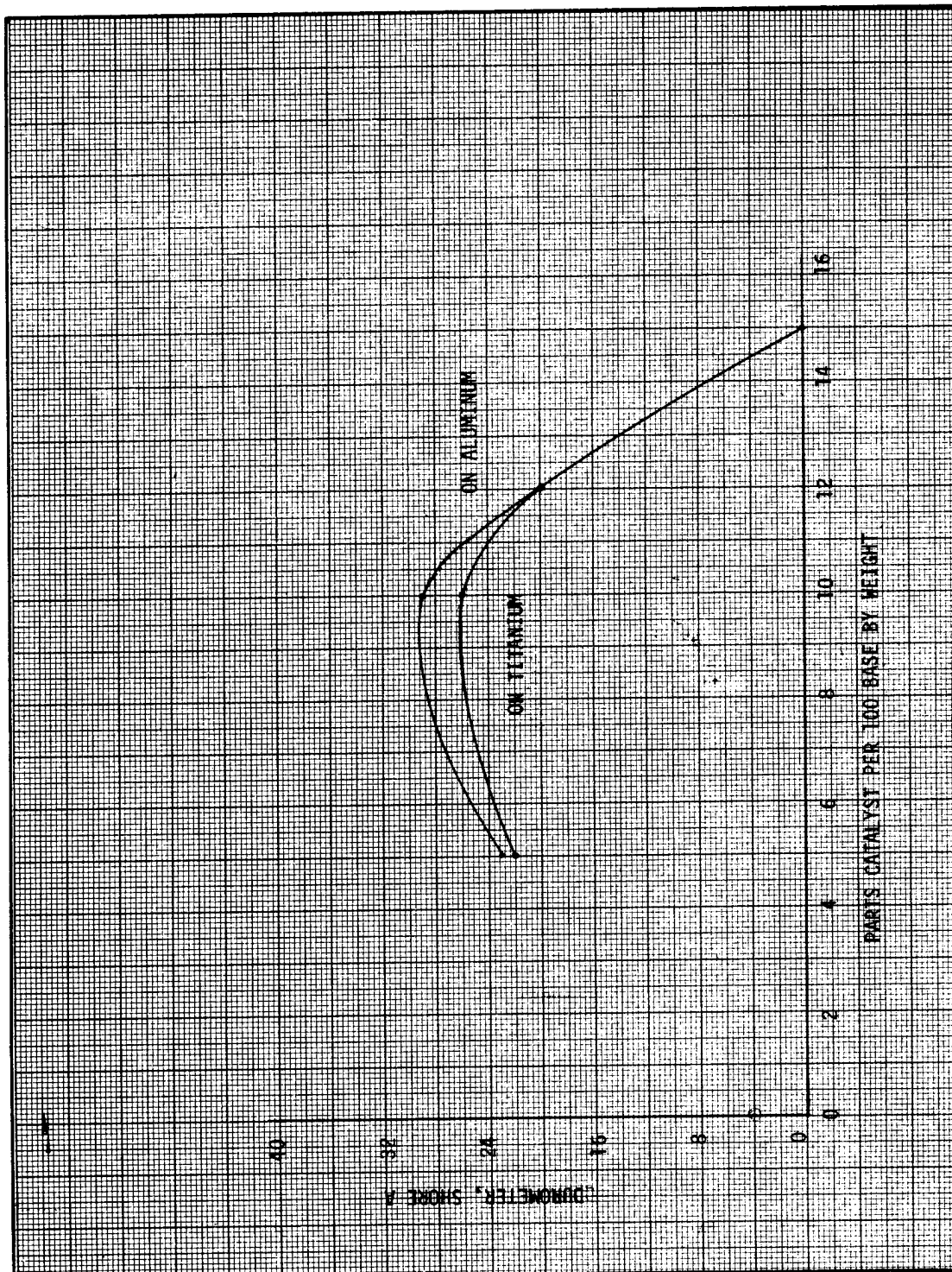

Fig. 14

CALC			REVISED	DATE	EFFECT OF CATALYST RATIO ON HARDNESS ROOM TEMPERATURE CURE	
CHECK						
APR						
APR						
THE BOEING COMPANY						PAGE

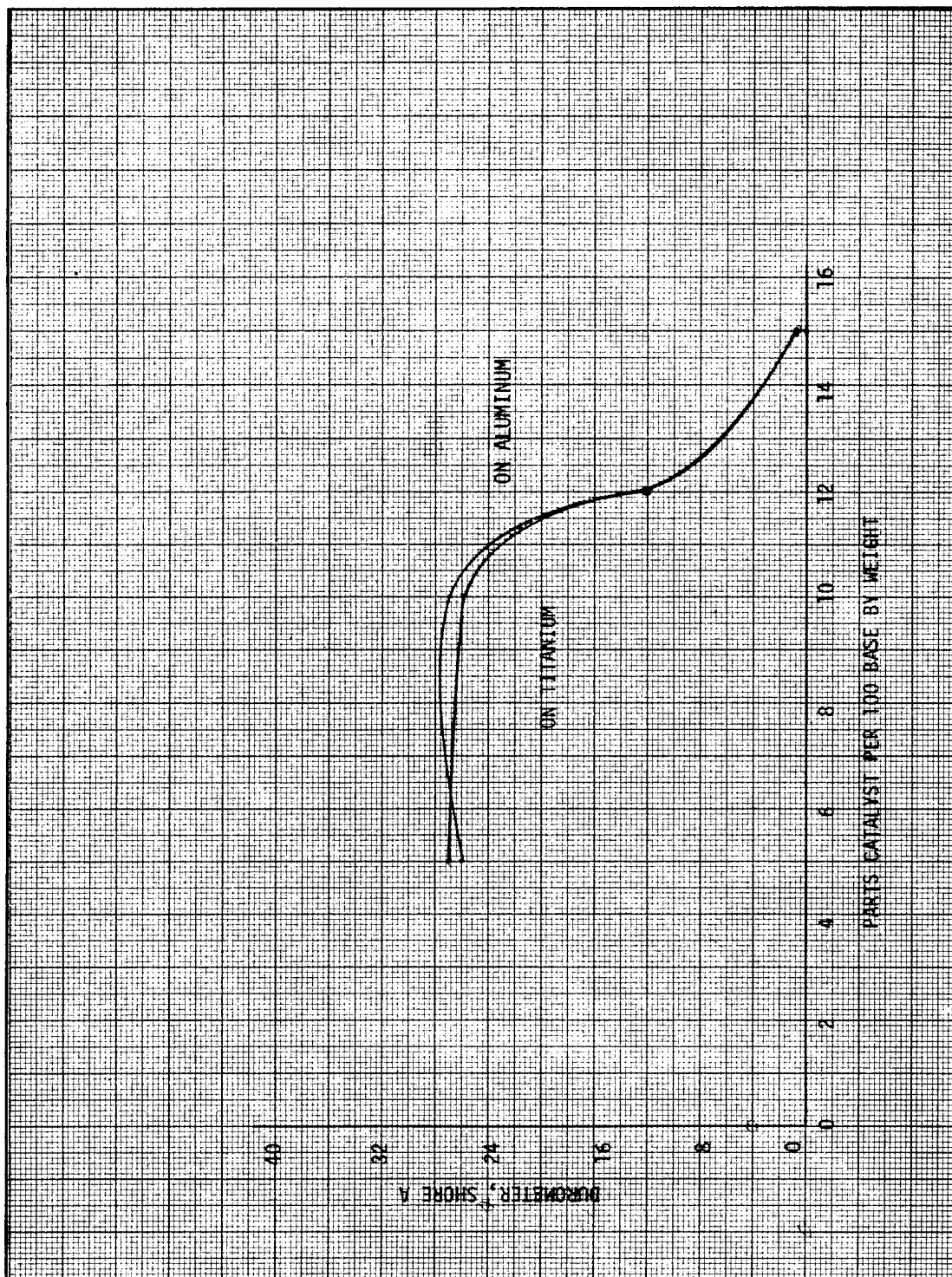

Fig. 15

CALC		REVISED	DATE	EFFECT OF CATALYST RATIO ON HARDNESS DC 77-028 160°F CURE	
CHECK					
APR					
APR					
				THE BOEING COMPANY	PAGE

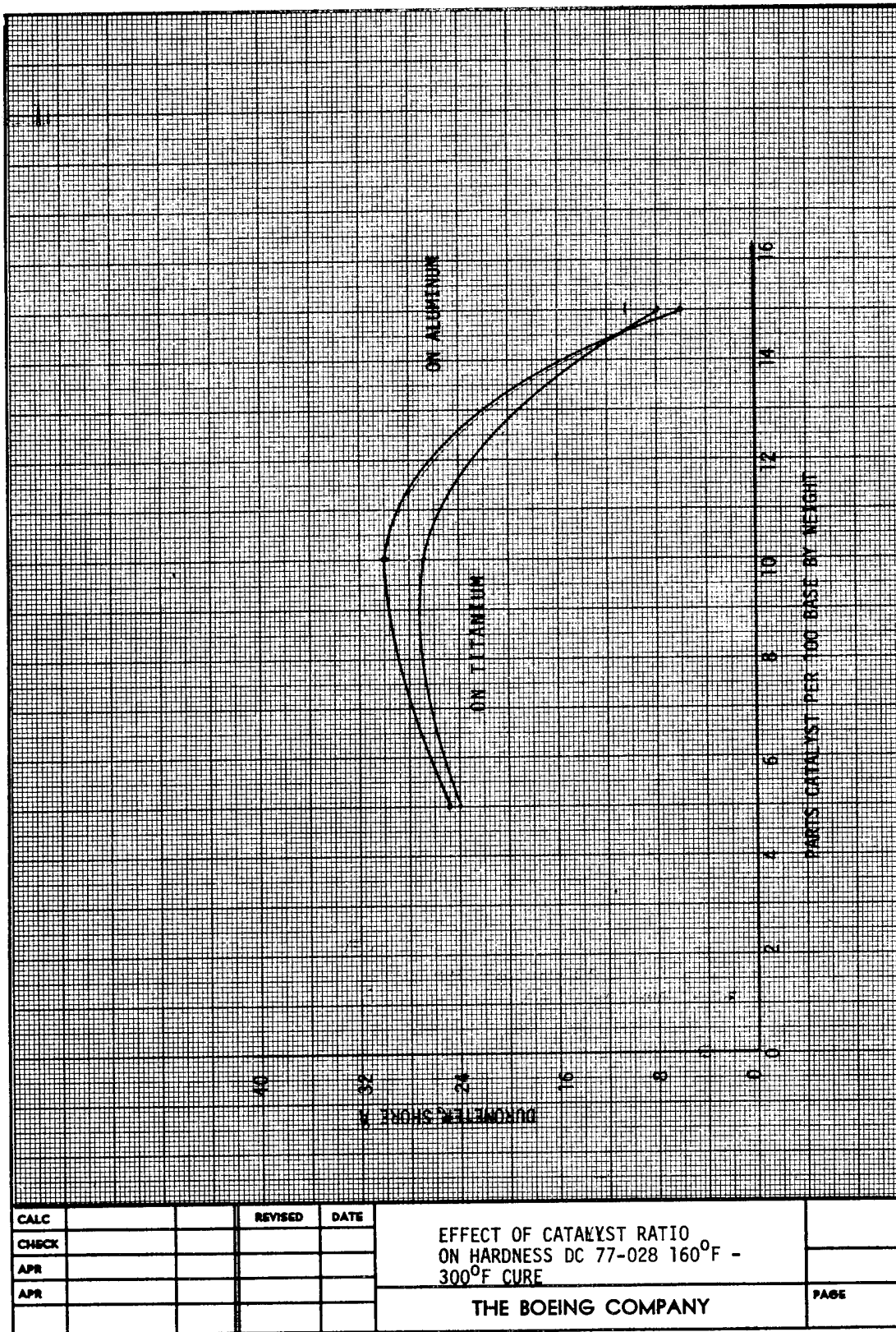

Fig. 16

CALC		REVISED	DATE	EFFECT OF CATALYST RATIO ON HARDNESS DC 77-028 160°F - 300°F CURE	PAGE
CHECK					
APR					
APR				THE BOEING COMPANY	

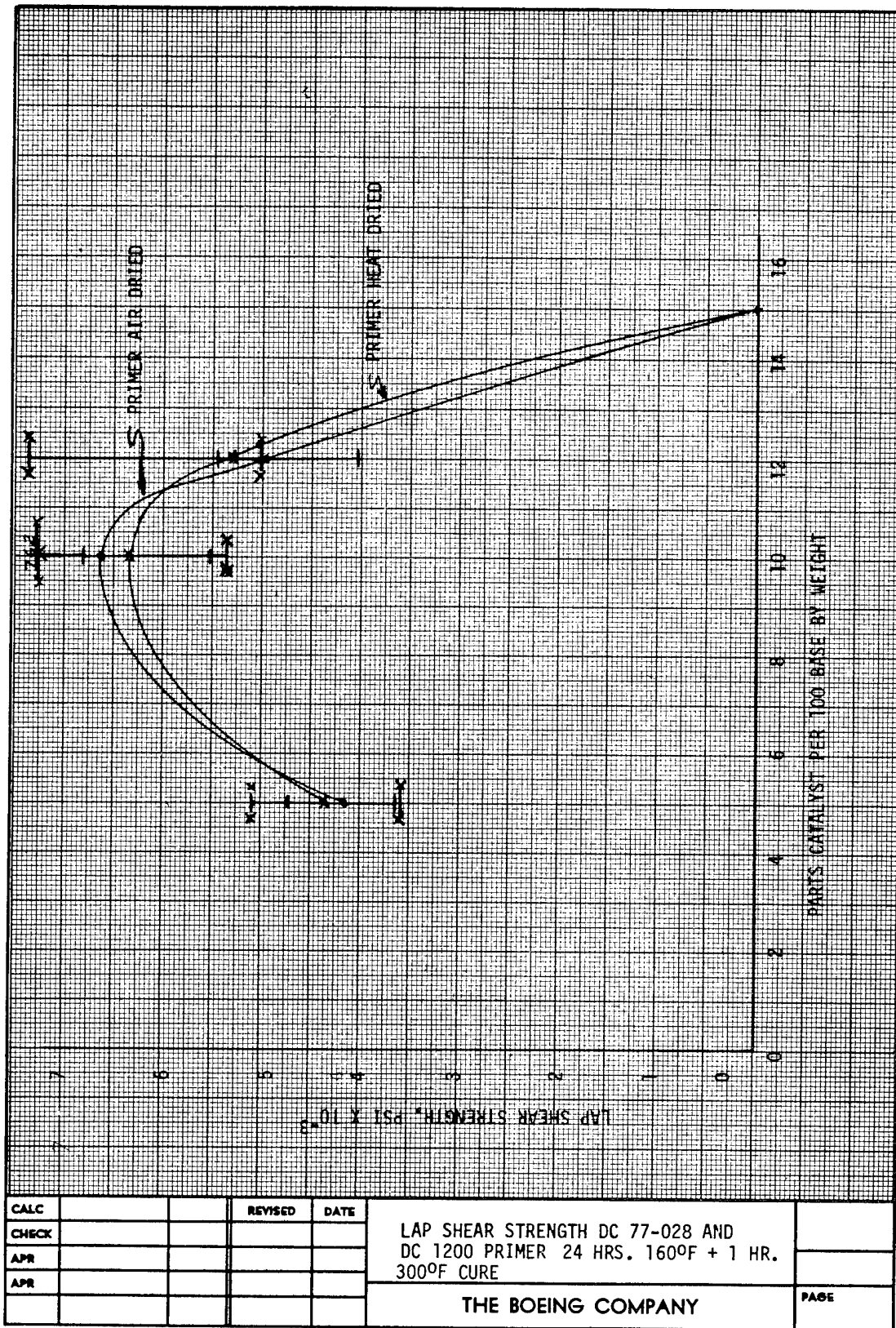

Fig. 17

SUMMARY AND CONCLUSIONS

- o RATIO OF 10 PPH CATALYST TO BASE IS OPTIMUM WITH A LOWER AMOUNT BETTER THAN A LARGER AMOUNT.
- o PRESENCE OF TITANIUM AND ITS OXIDES MAY INHIBIT CURE.

Fig. 18

JPL SEALANT LIFE PREDICTION STUDIES^{*}

J. Moacanin
Jet Propulsion Laboratory
Pasadena, CA

The long range goal of JPL studies is to develop test methods for the prediction of lifetime for elastomeric sealant composition from short term tests. The approach is based on the extensive studies on elastomers carried out at JPL which showed that when the stress-strain-time relationships for an elastomer in simple tension, failure included, are normalized appropriately (Fig. 2), a surface (i.e., tensile property surface) (Fig. 1) having a universal shape ensues (Fig. 3). Because of the "universality" of this surface it is possible to greatly extend the effective time scale and to make reasonable life-time predictions for different deformation modes over times far in excess of the duration of experiments; for ex., Fig. 4 shows data on two different ethylene-propylene elastomer compositions.

The work performed on the DC 77-028 fluorosilicone sealant showed that the tensile property surface for this composition has the same shape as that of other elastomers and that the shape remains unchanged even after chemical degradation, i.e., aging (Fig. 5). It was also established that both the tensile strength and the elongation at break of degraded samples can be predicted from data obtained from equilibrium swelling measurements alone (i.e., cross-link density determinations) in conjunction with a knowledge of the tensile property surface. This establishes that changes in sealant properties produced by chemical degradation can be estimated from a knowledge of change in cross-link density.

* This report represents one phase of research carried out at the Jet Propulsion Laboratory, California Institute of Technology, under Contract No. NAS7-100, sponsored by the National Aeronautics and Space Administration. Presented at Amès Research Center, July 25, 1974.

It was established from sol-gel measurements and stress relaxation measurements that the primary mode of chemical degradation for the DC 77-028 sealant in fuel at elevated temperatures is one of crosslink scission with extensive recombination; only minor amounts, estimated to be less than about 5%, of random chain scission occurs (Figs. 6 and 7). This sealant system represents the first known case where chemical degradation occurring via crosslink scission was established. In addition, this system is unique in that very extensive recombination of the broken crosslinks also occurs concomitantly with crosslink breakage.

The second phase of the effort is directed toward the development of methods which would use failure criteria based on the "property surface" obtained from experiments in simple tension to predict multiaxial failure in a fillet (Fig. 8). For the initial approach a stress analysis was carried out on the Boeing fillet flex test configuration (Fig. 9). This analysis can be extended to the DOW dynamic cup test (Fig. 10). For extension, the deformation is nearly identical to the Boeing test, i.e., circular vs. linear fillet; the torsion mode would have to be added. An analysis was carried out for the Boeing test, using a somewhat idealized configuration (Fig. 11) along with the linear elastic theory. The analytic solution was used to ensure that boundary conditions for the more exact numerical analysis (Fig. 12) approach the proper limits. Results of preliminary analysis for radial stress (Fig. 13) and tangential stress (Fig. 14) are shown.

To provide the necessary experimental input, strip biaxial tests are planned to be carried out on the sealants. These tests will provide the link with uniaxial tests. Also examination of fillet deformation shows that strip biaxial deformation is a reasonable approximation for a number of in-service conditions.

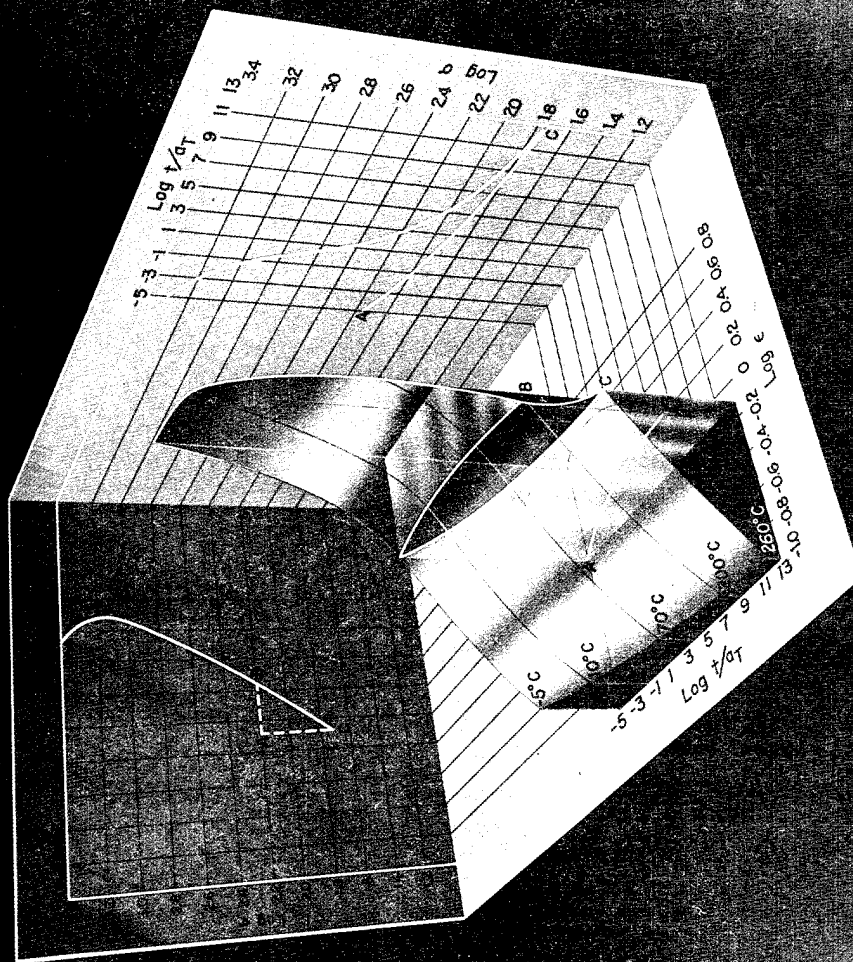

Fig. 1



2

"PROPERTY SURFACE" IS UNIVERSAL IN NORMALIZED COORDINATES

COORDINATES:

$$\sigma = \frac{v_e h(\phi) v_2^{1/3}}{T_0}, \quad \epsilon = \frac{t}{T}, \quad \text{AND} \quad \tau = \frac{t}{a_T (a_x a_\phi) a_c}$$

RELATIONSHIPS:

	σ	ϵ	τ
TEMPERATURE	T_0/T	1	a_T
CROSSLINK DENSITY	v_e	1	a_x
FILLER	$h(\phi)$	1	a_ϕ
PLASTICIZER (AND/OR SOL FRACTION)	$v_2^{1/3}$	1	a_c

PROPULSION DIVISION
POLYMER RESEARCH SECTION

JM
382
7/25/74

Fig. 2

UNIVERSALITY OF SHAPE OF
TENSILE PROPERTY SURFACE

- SBR RUBBER, FILLED AND UNFILLED
- VITON
- DIMETHYLSILOXANE (FILLED SILICONE RUBBER)
- EPR RUBBER, FILLED AND UNFILLED
- BUTYL RUBBER, FILLED AND UNFILLED
- FLUOROSILICONE RUBBER, FILLED AND UNFILLED
- FLUOROSILICONE SEALANT COMPOSITIONS
- EPT-10 AND AFE-233 IN HYDRAZINE (DIFFERENT FILLERS)



TENSILE STRAIN FAILURE ENVELOPE FOR AF-E-332 AND EPT-10

4

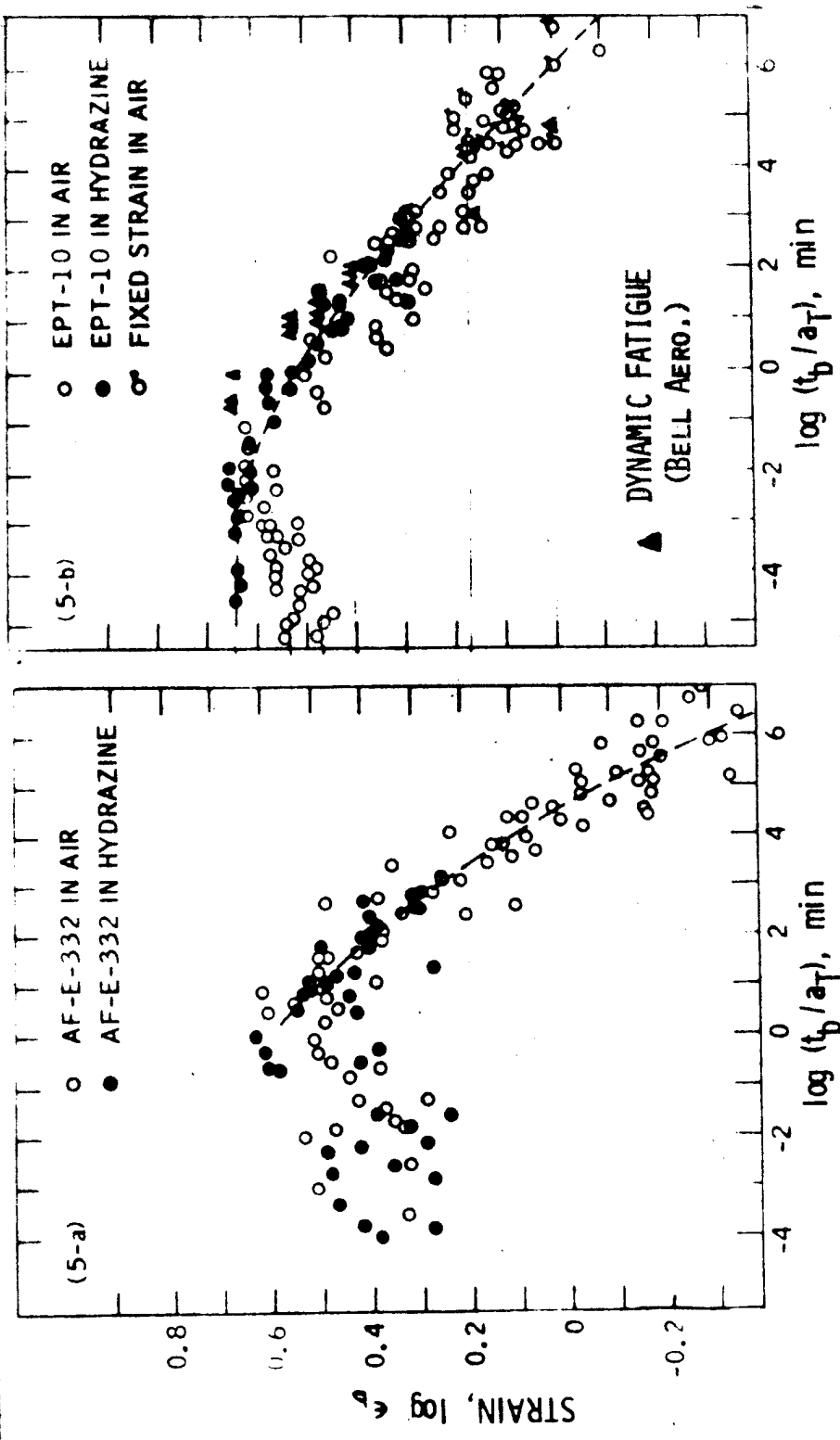

PROPELSION DIVISION
POLYMER RESEARCH SECTION

382
7/25/74

Fig. 4



EXTENSION TO AGED ELASTOMERS

- "PROPERTY SURFACE" SHAPE REMAINED UNCHANGED FOR FLUOROSILICONE FUEL TANK SEALANTS AFTER AGING AT ELEVATED TEMPERATURE IN PRESENCE OF FUEL VAPOR; HENCE, CHANGES IN PHYSICAL PROPERTIES FROM AGING CAN BE INFERRED FROM CHANGES IN CROSSLINK DENSITY AND SOL FRACTION AND FOR EXTENT OF SWELLING (BY FUEL).

PROPULSION DIVISION
POLYMER RESEARCH SECTION

JM
382
7/25/74

Fig. 5



6

SUMMARY OF DC77-028 CHARACTERIZATION

SEALANT CHARACTERIZED BY "UNIVERSAL" TENSILE PROPERTY SURFACE

PROPERTY SURFACE SHAPE REMAINS UNCHANGED EVEN AFTER EXTENSIVE DEGRADATION; HENCE, CHANGES IN TENSILE PROPERTIES DETERMINED BY CHANGES IN ν_e AND SOL/GEL

MEANINGFUL ACCELERATED AGING CONDITIONS ARE DIFFICULT TO ACHIEVE (CHEMICAL PROBLEM)

SEALANT DEGRADES MAINLY AT CROSSLINKS; RECOMBINATION REACTIONS ARE EXTENSIVE

PROPULSION DIVISION
POLYMER RESEARCH SECTION

JM
382
7/25/74

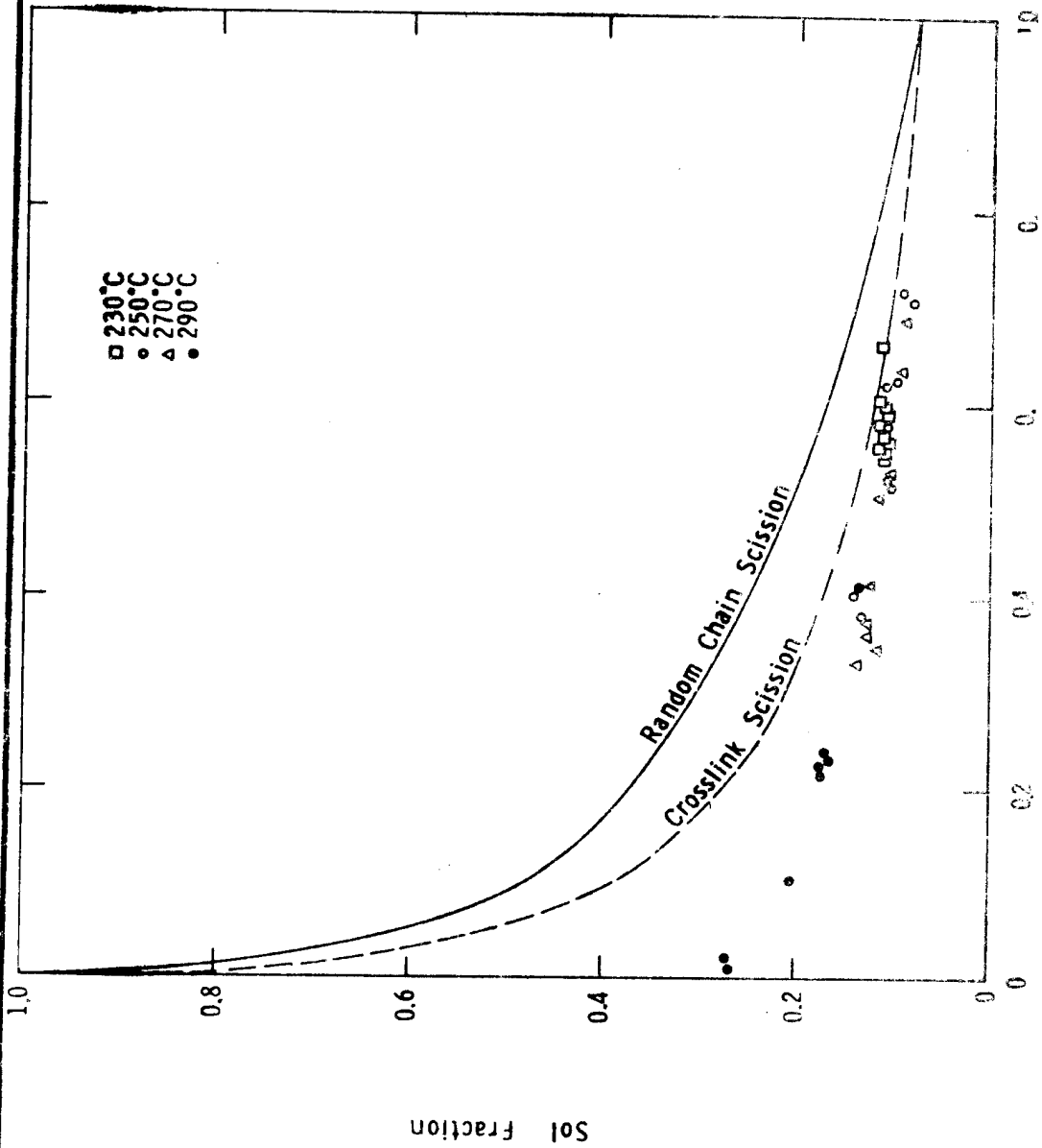

Relative Network Chain Concentration

Fig. 7

LIFETIME UNDER MULTIAXIAL LOADS (IN PROGRESS)

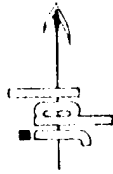

- EXTENSION TO MULTIAXIAL LOADS EVALUATED BY:
- NUMERICAL STRESS ANALYSIS OF BOEING FILLET FLEX TEST (UNDERWAY)
- STRIP BIAXIAL CONSTANT STRAIN-RATE FAILURE DATA TO BE USED FOR COORELATION WITH UNIAXIAL "PROPERTY SURFACE." AS APPROXIMATION TO FILLET CONDITION

BOEING SEALANT DEFLECTION TEST



Fig. 9

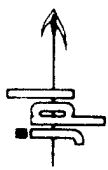

DOW DYNAMIC TEST

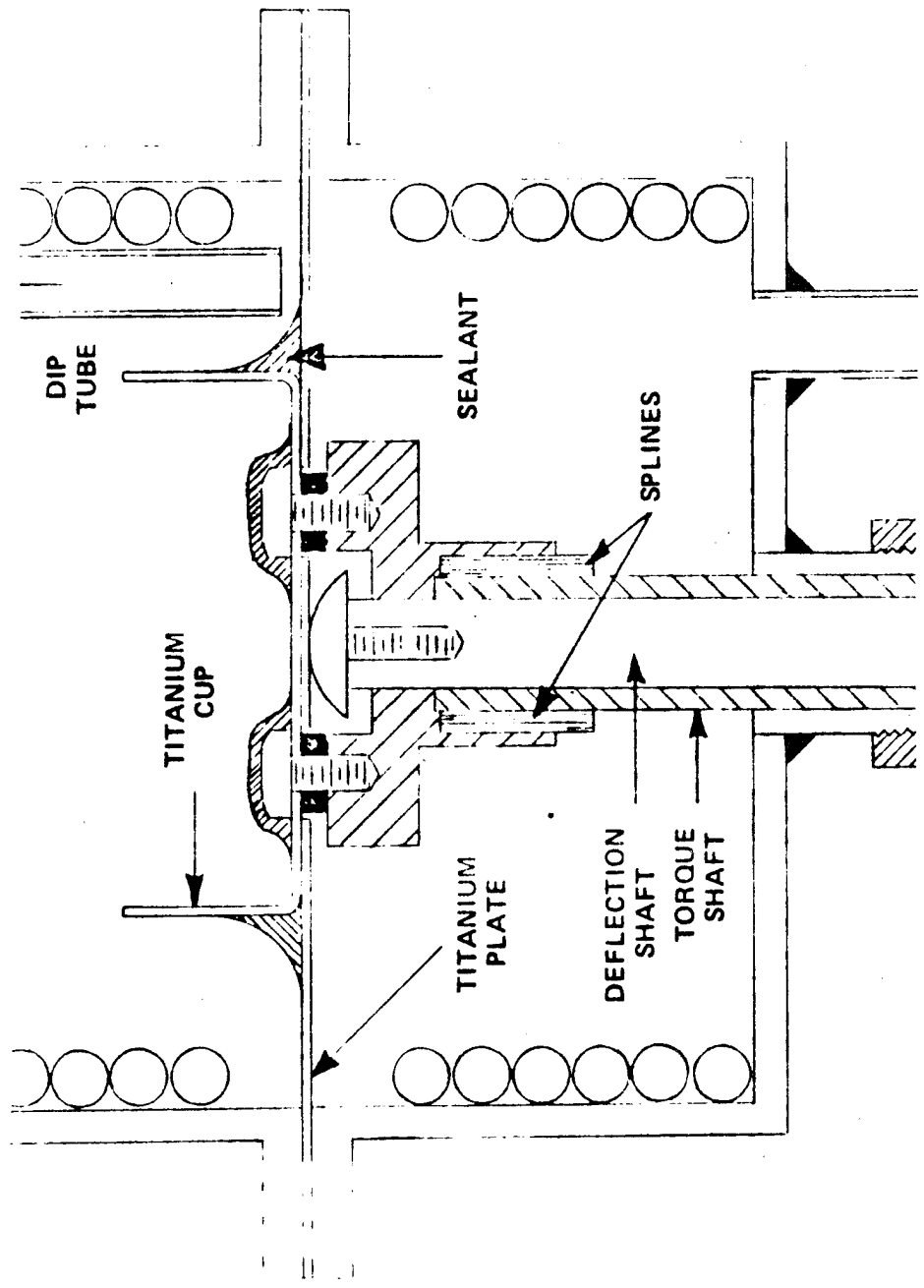

PROPULSION DIVISION
POLYMER RESEARCH SECTION

JM
382
7/25/74

Fig.10

SEALANT CONFIGURATION

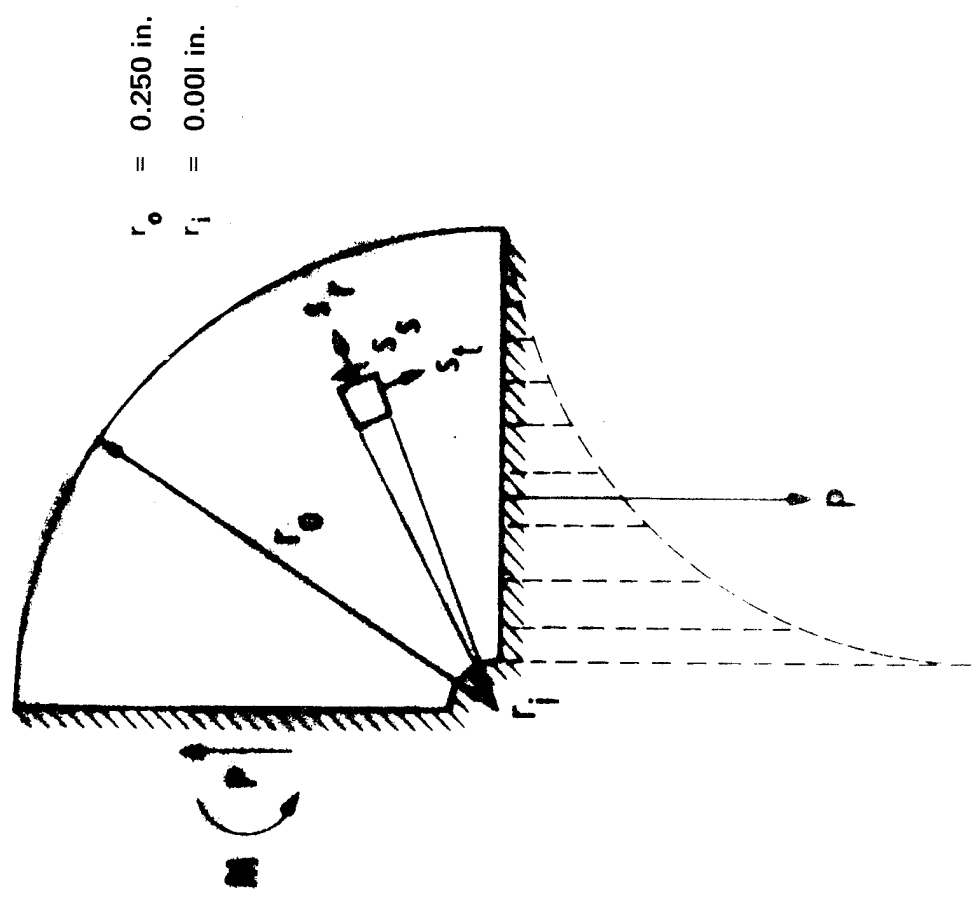

Fig.11

SEALANT CONFIGURATION

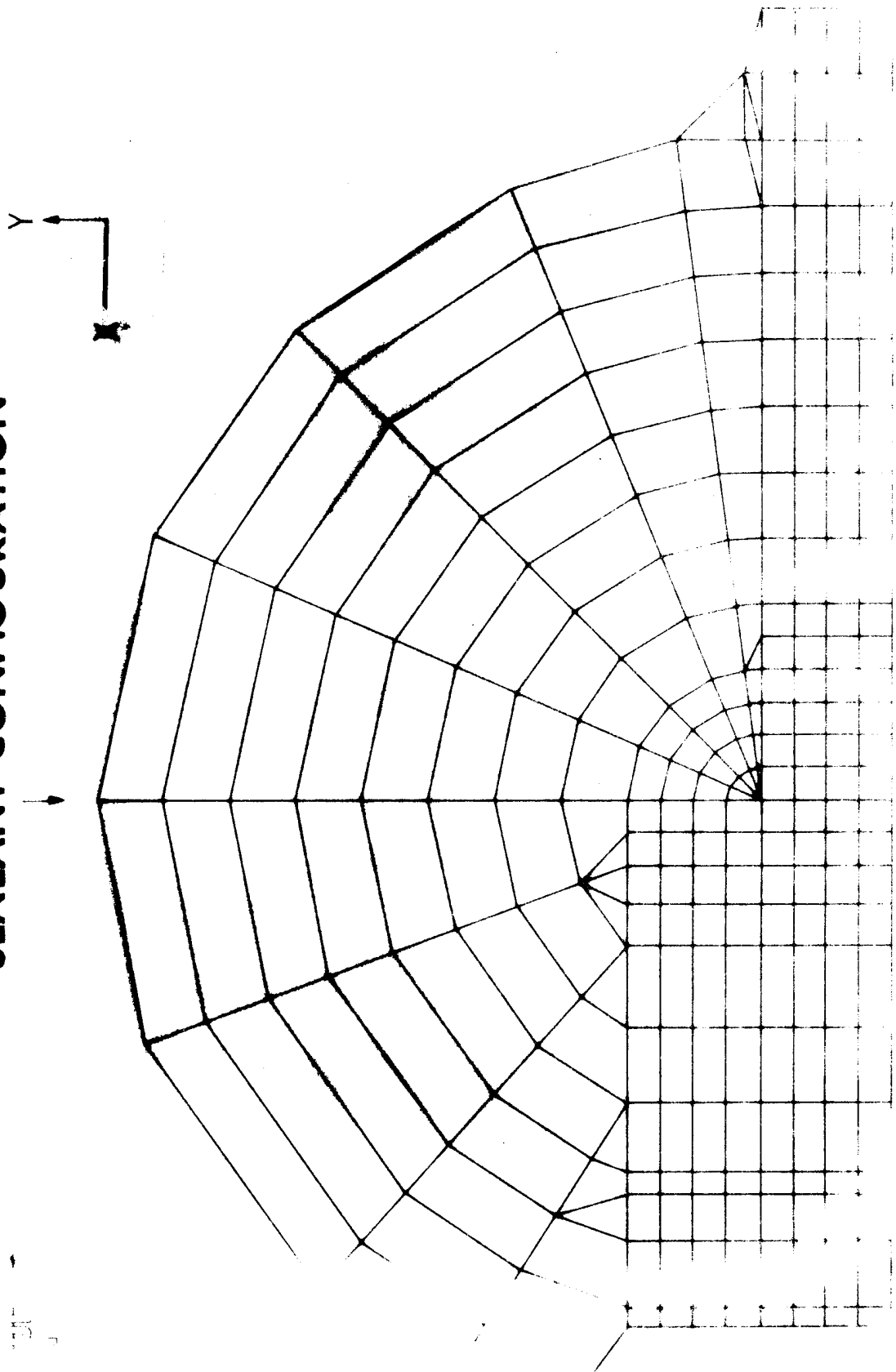

Fig. 12

CASE 3

RADIAL STRESS

PSI

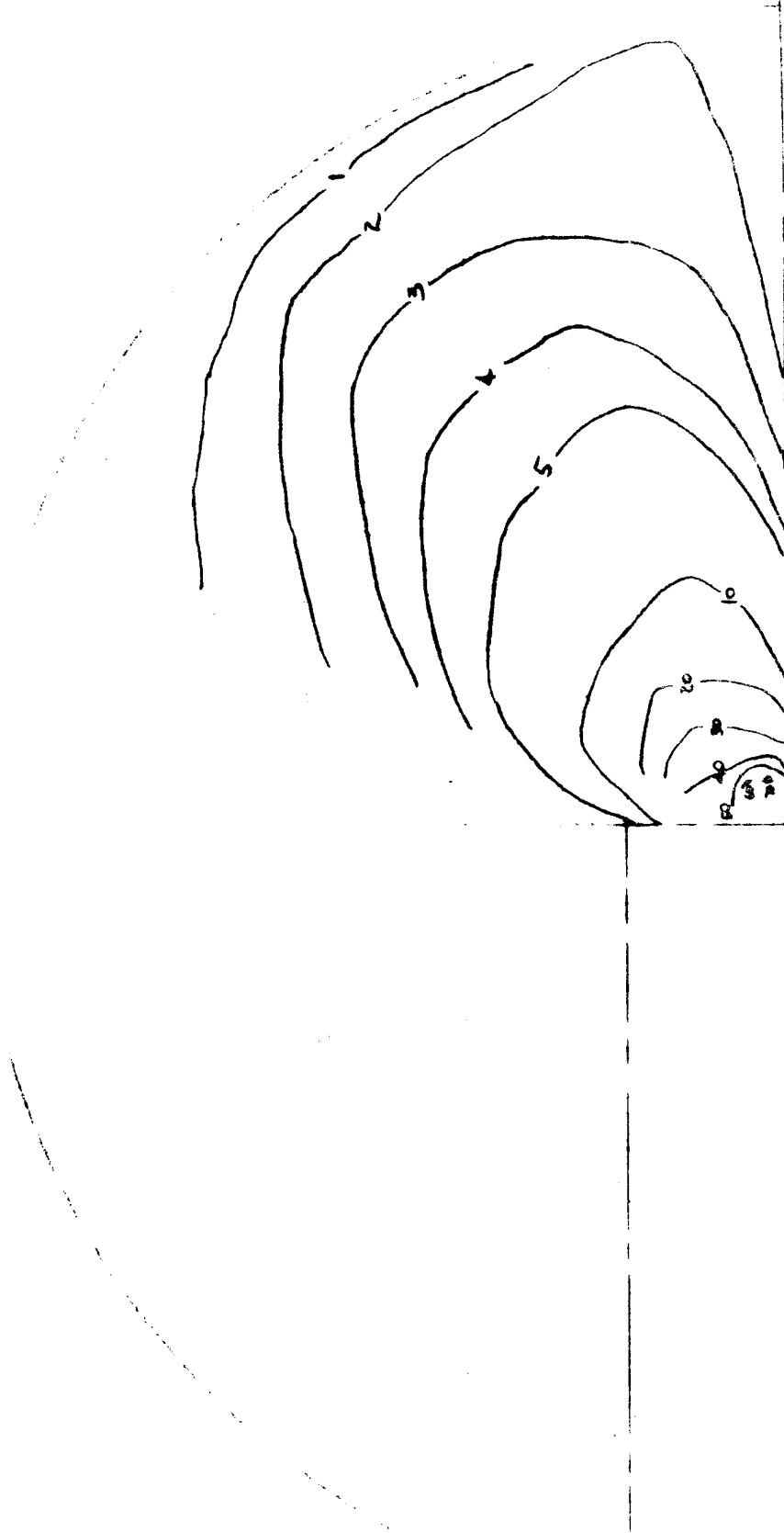

Fig. 13

CASE 3
TANGENTIAL STRESS
PSI



Fig. 14

PERFLUORINATED POLYETHERS FOR SEALANT APPLICATION

Dr. Ralph de Pasquale
PCR, Inc.
Gainesville, Florida

Technological advances in the field of aeronautics and astronautics have created a demand for materials of construction which will function for extended period in extreme environments. These requirements have necessitated a broad research and development program within Governmental agencies, particularly in the area of non-metallic materials such as sealants and elastomers, designed to provide solutions to both immediate and anticipated problems.

Sealants are required that exhibit high thermal stability, low temperature flexibility, resistance to fuels, and titanium compatibility. This effort is direct toward the preparation of fuel tank sealants which will maintain bonding properties under extreme conditions. The project is devoted to the synthesis of long chain perfluoroaliphatic ether based polymers since these materials have demonstrated unusually desirable properties. To cite two examples, "Krytox" (the perfluoroalkylene polyethers of du Pont) and the linear perfluoroalkylene polyether substituted triazines developed at PCR have excellent low and high temperature properties.

In general, fluorocarbon polymers have shown reduced mechanical properties when compared to their hydrocarbon analogs. While fluoropolymers can be vulcanized, the loss in mechanical properties may be attributed to the cross-linking segment. In many instances this segment is chemically "weaker" than the initial fluorocarbon backbone. This problem may be circumvented by simultaneously polymerizing and cross-

linking difunctional fluorocarbon ether materials in which the resultant three dimensional structure contains only thermal-oxidatively stable links.

The objective of this program is the preparation of long chain perfluoropolyethers with functional terminal groups and the investigation of methods of converting them to stable cross-linked polymers for sealant applications.

At the onset the program was directed toward the synthesis of long-chain perfluoroalkylene ether dinitriles and diisocyanates and conversion of these materials to polytriazines and polyisocyanurates, respectively. As the work proceeded, emphasis gradually shifted from isocyanates to acetylenes.

DISCUSSION OF SLIDE I

The near ultimate candidate sealant material should possess the following properties: thermo-oxidative stability (air stability to ca 400°C), low temperature properties ($T_g \sim -50^\circ\text{C}$), solvent resistance (hydrocarbon fuels), and hydrolytic stability. These strenuous requirements dramatically minimize applicable chemical structures. A structure which is expected to possess such properties is a perfluorinated alkylene ether, $(R_fOR_f)_n$. Commercial materials of this type are available, e.g., Krytox (du Pont) and Fomblin (Montedison) Fluids; however, as their names imply, they are fluids. Current technology which could lend to high molecular weight perfluorinated alkylene ethers is non-existent. As a substitute we chose to study systems which would closely approximate such structures. These would consist of high molecular weight perfluoroalkylene ethers with two terminal functional groups. By appropriate chemical sequences these functional groups could be converted to stable aromatic or heteroaromatic rings via chain extension or polymerization reactions. Thus, the final structure would consist of perfluoroalkylene ether units joined by a stable ring.

SLIDE I

Thermo-oxidative Stability

Low Temperature Properties

Solvent Resistance

Hydrolytic Stability

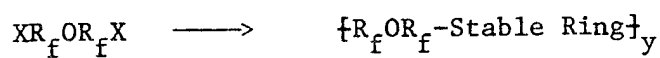

Stable Ring = aromatic or heteroaromatic

R_fOR_f = High molecular weight prepolymer

DISCUSSION OF SLIDE II

The initial synthetic approach was to simultaneously polymerize and cross-link the difunctional perfluoroalkylene ether to a three dimensional matrixed material. The functional groups chosen for study were nitriles and isocyanates, which would be chemically converted to triazines and isocyanurates, respectively. Another functional group of interest not shown on the slide would be an acetylene, which could be converted by trimerization to an aromatic ring. To date, our major emphasis has been on the dinitriles. At an early stage of experimentation, emphasis was shifted from the isocyanates to the acetylenes. For the sake of brevity, work on the isocyanates will not be presented at this time.

SLIDE II

Difunctional Material $\xrightarrow[\text{link simultaneously}]{\text{Polymerize and cross-}}$ 3-Dimensional Matrixed Material

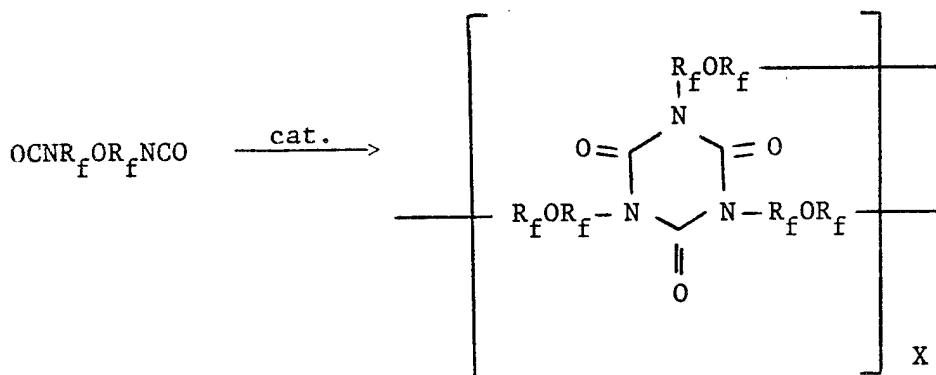
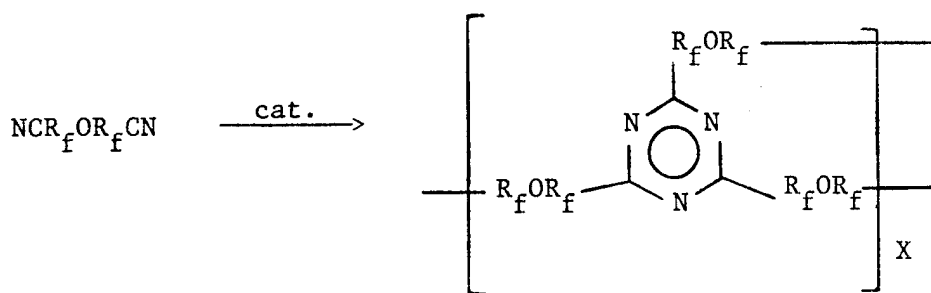

Polytriazines and Isocyanurates

DISCUSSION OF SLIDES III AND IV

During the initial stage of this contract sizeable quantities of perfluoroalkylene ether diacid fluorides (EDAFs) and subsequently dinitriles were prepared by routes previously described in the patent literature. Routes to these materials are shown in Slides III and IV. The dinitriles derived from 6,7,8-EDAF, and 7-EDAF dimers were prepared and isolated. Samples of several of these materials were sent to NASA.

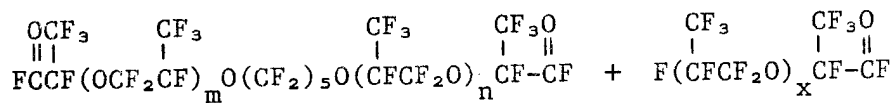
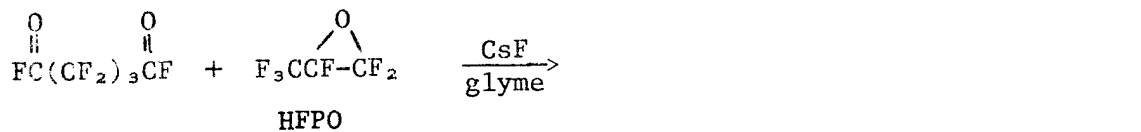

EDAFs

$$m + n = 4 - 7$$

$$x = 3 - 7$$

$$m + n = 5; \text{ 7-EDAF b. p. } 127^\circ/0.5 \text{ mm}$$

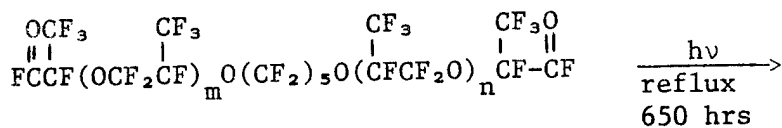

$$m + n = 5 - \text{ 7-EDAF}$$

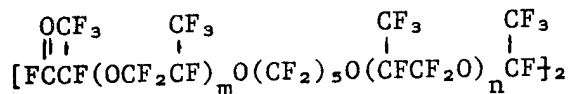

$$m + n = 5$$

7-EDAF Dimer

89% Conversion

73% Selectivity

B.P. 224-235° at 0.8 - 1 mm

DISCUSSION OF SLIDE V

Treatment of either 8-EDAF or 7-EDAF dimer dinitrile with ca. 1% (mole) of NH_3 at ca. 220° afforded three dimensional polytriazines that possessed the thermal and low-temperature properties shown in the slide. However, these materials had poor mechanical properties; they were easily broken or sliced. Samples of these materials were submitted to NASA.

The observed mechanical properties of these materials might be due to the fact that for each triazine ring formed, the nitrile functionality increases by one. Due to the length and the flexibility of the fluorinated ether connecting groups, it is conceivable that after a minimal number of rings are formed, nitrile substituents from adjacent rings in the same chain may react with each other to form triazines. Continuation of this process would lead to a tight, interwoven ball that would be expected to possess poor elongation.

SLIDE V

EDAF Dinitrile $\xrightarrow{\text{NH}_3}$ 3-Dimensional Polytriazines

Polymerized and Cross-Linked Simultaneously

Thermal - TGA Break $\sim 500^\circ\text{C}$

Low Temperature - <u>EDAF-DN</u>	<u>Tg ($^\circ\text{C}$, DTA)</u>
8	-40
7-Dimer	-60

Mechanical - Cheese-like, easily sliced

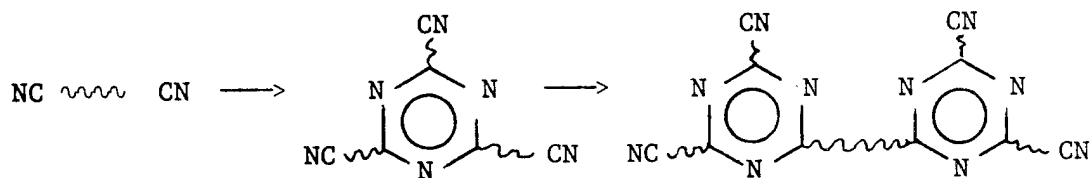

etc \rightarrow

tight ball,
poor elongation

DISCUSSION OF SLIDE VI

There are several approaches that could be applied to the enhancement of the mechanical properties and elasticity of these polytriazines.

1) It has been reported (Brown) that by mixing various proportions of monofunctional nitriles with dinitriles and subsequent conversion of these mixtures to polytriazines, products with physical properties ranging from infusible to intermediate elastomeric products to fluids are obtained. With regard to our system, it is conceivable that dilution of the initial dinitrile mixture with monofunctional nitrile could increase linearity at the expense of cross-linking, resulting in a more elastomeric material.

Mixtures of 8-EDAF dinitrile and varying amounts of either

$\begin{array}{c} \text{CF}_3 \\ | \\ \text{C}_3\text{F}_7\text{O}(\text{CFCF}_2\text{O})_2\text{CFCN} \end{array}$ or $\begin{array}{c} \text{CF}_3 \\ | \\ \text{C}_7\text{F}_{15}\text{CN} \end{array}$ were subjected to polymerization conditions.

The resulting polymers derived from a high percentage of monofunctional nitrile in the initial mix were more tacky. However, this could be due to the effect of the plasticizing action of a low molecular weight triazine formed during polymerization. In general there seemed to be slight improvement in the cheese-like properties of these materials as indicated by a qualitative manual examination of the stretch, feel, etc., of the resulting polymer. We have yet to investigate the effect of fillers/reinforcers on the mechanical properties of this material.

2) It is documented (Hooker) that polytriazines derived from perfluoroaliphatic dinitriles are tough, and in some cases brittle. Thus, it

is conceivable that, by mixing an fluoroaliphatic dinitrile with a long chain fluoroaliphatic ether dinitrile and subsequently polymerizing this preformed mixture to a polytriazine, the material that results would display properties intermediate between the polytriazine derived from homopolymerization of the nitriles.

In the second approach, various mole % mixtures of 7-EDAF dimer dinitrile and perfluorosebaconitrile were polymerized with catalytic amounts of ammonia at ca. 225°C. The results of these experiments are shown in the slide. These materials gradually lost their cheese-like properties as Tg increased; the material with Tg = -20° was tough. However, for the materials with Tg $\bar{<}$ -20° the elongation was not influenced to any appreciable extent.

SLIDE VI

APPROACHES TO IMPROVE MECHANICAL PROPERTIES

- 1) Increase linearity by decreasing functionality

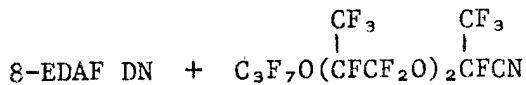

A

Polymerize >

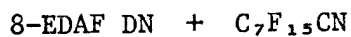

B

Mole ratio from 10:1 to 3:1

Mixed polymers generally harder than pure DAF

- 2) Mixed Dinitriles

<u>7-EDAF Dimer (g)</u>	<u>NC(CF₂)₈CN (g)</u>	<u>Tg (°C)</u>
5	--	-60
2.5	1.5	-40
2.5	2.5	-20
1	5	+10
--	5	>100 (plastic)

The harder the material, the greater the Tg, the less cheese-like

DISCUSSION FOR SLIDE VII

3) Lastly, a linear poly(imidoylamidine) could be prepared and, in a separate step, ring closed by reaction with a $R_f\text{COF}$ or $(R_f\text{CO})_2\text{O}$ compound. If a certain percentage of the R_f groups contained a C_6F_5 or a CN ($\text{C}\equiv\text{CH}$) substituent, the resulting polymer could be cured with a diphenoxide salt or a dinitrile oxide, respectively. A pendent CN group (Hooker) also could be cured with a variety of catalysts including $(\text{Bu}_3\text{Sn})_2\text{O}$, $\phi_4\text{Sn}$, or $(\text{Bu}_3\text{Sb})_2\text{O}$. The resulting material would be a cured completely triazine system, i.e., triazine rings linking perfluoro-alkylene ether groups with triazine rings as stable cross-links.

In this approach a perfluorinated alkylene ether poly(imidoylamidine) was prepared using 8-EDAF dinitrile as the starting material. The procedure involved conversion of the dinitrile to the diamidine which was a viscous oil. The diamidine was then treated with an equivalent of more dinitrile at 25°C in Freon E4 solvent. The reaction proceeded smoothly as judged by infrared. The amidine and nitrile bands disappeared and were replaced by imidoyl amidine bands. The resulting moderately viscous solution was then treated with an excess of trifluoroacetic anhydride and on concentration afforded a viscous, barely flowable, material showing only triazine bands in the infrared.

By modification of the last step in the sequence, pendent groups can be incorporated into this material affording a prepolymer which is then amenable to cross-linking or chain extension. Hooker Chemical Company has used a similar procedure for preparing fluoroaliphatic triazine

polymers containing pendent CN groups. Unfortunately, the compound used

in Hooker's study, $[\text{NC}(\overset{\text{O}}{\parallel}\text{C}(\text{CF}_2)_3)_2\text{O}]_n$, was prepared by a tedious synthesis.

We have considered alternate syntheses which are flexible so that, if successful, they could include the incorporation of several (CN, C₆F₅, CF=CF₂, C≡CH) pendent groups. It should be noted that closure of the poly(imidoamidine) to the triazine can also be affected by the use of an acid fluoride as well as an anhydride. Thus, our approach centered upon the syntheses of bifunctional materials, one of which is a COF group.

SLIDE VII

3) Prepare linear triazines and cross-link through pendent groups

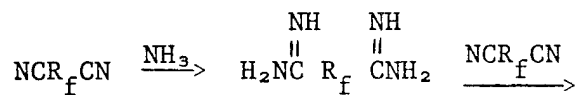

Diamidine

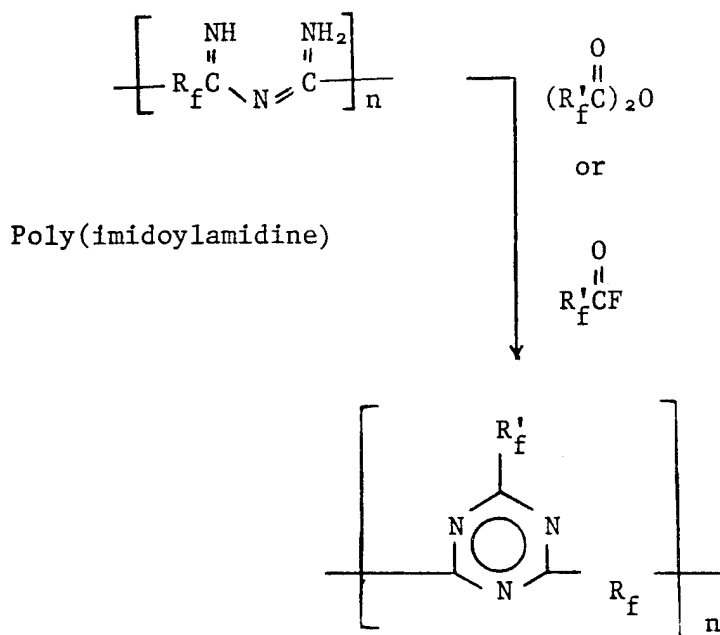

R'_f = Mixed CF_3 and $(\text{CF}_2)_n\text{X}$ where X = functional group (cross-link site)

X = CN, $\text{C}_6\text{F}_5\text{O}$, $\text{C}\equiv\text{CR}$

Hooker Chemical Co. $\text{R}_f = (\text{CF}_2)_8$, Tg -15 to -5°C (cured, X = CN)

DISCUSSION FOR SLIDE VIII

The simplest acid fluoride containing a C_6F_5 (or XC_6F_4) group is pentafluorobenzoyl fluoride; however, at the onset it was not known whether an aryl acid fluoride would effect ring closure of an imidoylamidine. Pentafluorobenzoyl fluoride was prepared by halogen exchange (KF, tetraglyme, 67% yield). Reaction between this material and the imidoylamidine derived from $(HFPO)_4$ nitrile does not afford triazine even at 100° . In contrast $(HFPO)_4$ acid fluoride rapidly closes the same imidoylamidine at $25^\circ C$.

Apparently, the C_6F_5 group deactivates acid fluoride initiated ring closure of the imidoylamidine: this effect was expected but the magnitude of the effect (no reaction at $100^\circ C$) is surprising.

The first route on the slide was tested for the preparation of various substituted (CN, $CF=CF_2$, $C\equiv CH$, C_6F_5) fluoroaliphatic acid fluorides.

The aryl ester-acid was prepared in 46% yield ($Ar = C_6F_5$); however, on treatment with SF_4 in HF the product mixture was void of a COF band. The order of reactivity of several functional groups with SF_4 decreases in the order $CO_2H > CO_2R > COF$. From this datum the above synthesis was based on the selective SF_4 reduction of an ester in the presence of an acid fluoride. In the absence of HF, SF_4 reduction of esters is very slow at moderate temperature. The major product from the above SF_4 reduction arises from ring closure. While fluoroaliphatic acid fluorides are not appreciably reactive with SF_4 under the conditions of the experiment, it has been noted previously that the presence of $C=O$ groups γ to a COF group affords ring closed products on SF_4 treatment, presumably via a kinetically

avored, cyclic, low energy intermediate. Further work on this route was discontinued.

The second scheme is a potential route to a nitrile acid fluoride. According to earlier reports nitrile groups are unreactive to SF_4 at temperatures below $\sim 200^\circ$. The intermediate compound was prepared at 120° and the crude reaction mixture (roughly 85% desired component, 15% diester) was then treated with SF_4/HF at $85^\circ \text{C}/22 \text{ hr}$. Work-up afforded a good yield of one component whose structure was assigned from spectroscopic data. Apparently, the presence of HF enhances the activity of a CN group toward SF_4 .

SLIDE VIII

ATTEMPTED GENERAL PREPARATION OF

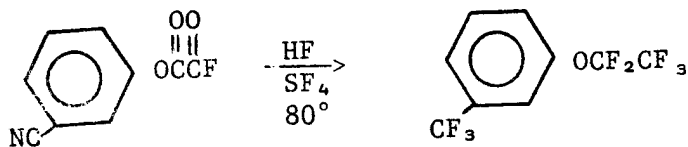
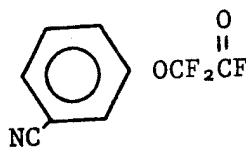
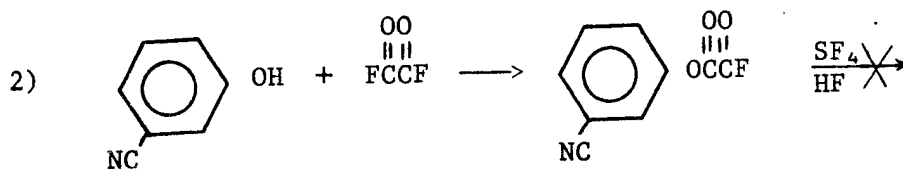
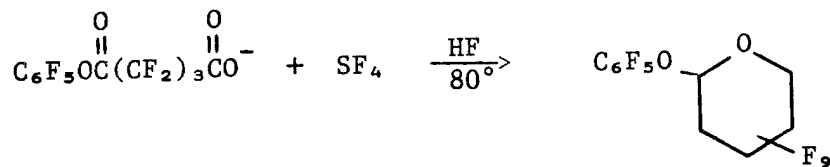
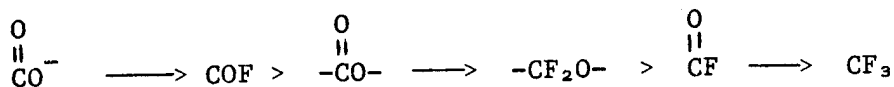
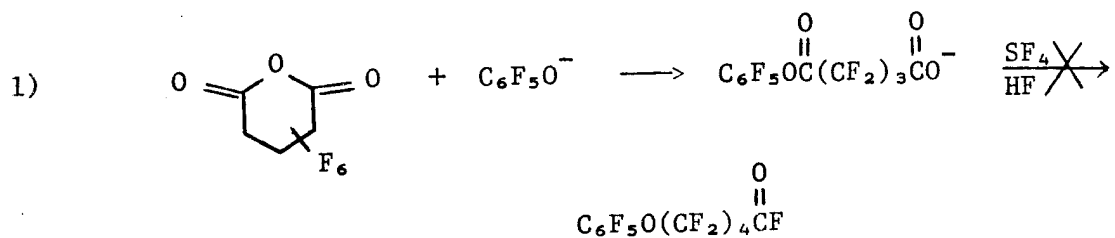
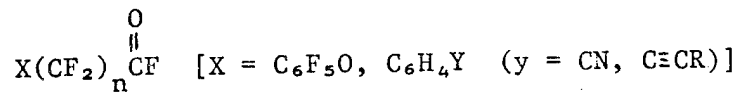

DISCUSSION OF SLIDE IX

At this stage it was decided that it would be more appropriate to pursue alternate syntheses at a latter stage of this effort. The Hooker route to a nitrile anhydride was then carried out as shown on the slide. Similarly, a du Pont route to a pentafluorophenoxy acid fluoride was run.

The poly(imidoamidine) derived from 8-EDAF was treated with excess $C_7F_{15}CN$ to convert any unreacted amidine function to imidoamidine groups. This material was then separated into two portions and treated with an 85:15 and 70:30 mole ratio of $(CF_3CO)_2O$: $[NC(CF_2)_3CO]_2O$, respectively. Volatiles were removed and the residue, a viscous liquid, showed both CN and triazine bands in the infrared. These samples should contain roughly 15 and 30% pendant CN groups on triazine rings. Both samples were submitted to NASA.

A similar reaction using a mixture of $C_6F_5OCF_2CF_2COF$ and $C_7F_{15}COF$ to ring close the polyimidoamidine is under investigation. Cross-linking studies of polytriazines containing pendent CN and C_6F_5O will follow.

SLIDE IX

Hooker Chemical Company Route

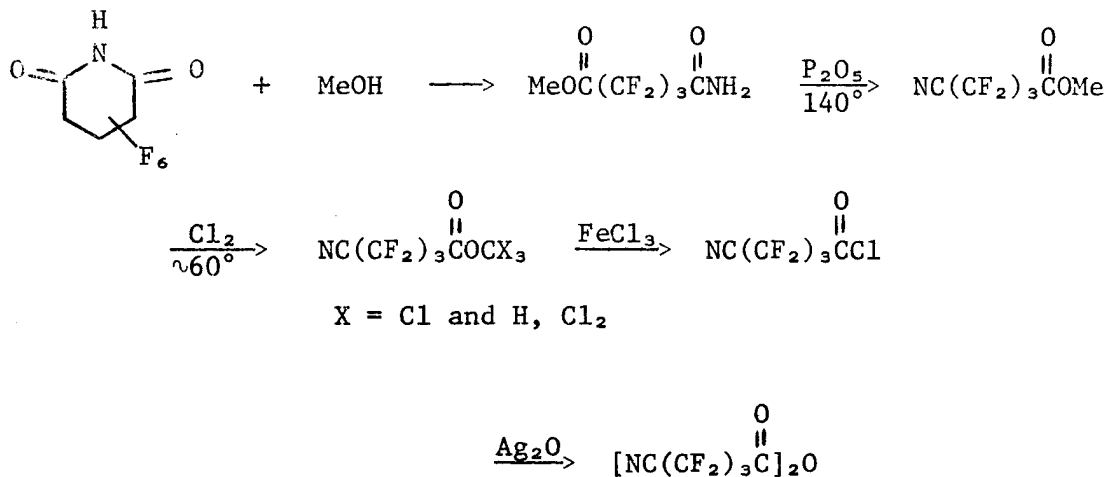

DuPont Route

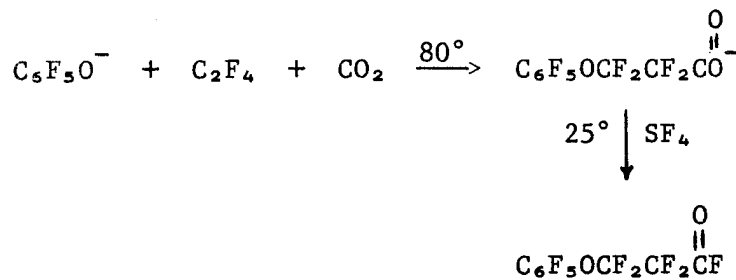

Polytriazazine with CN Pendant from 8-EDAF Dinitrile

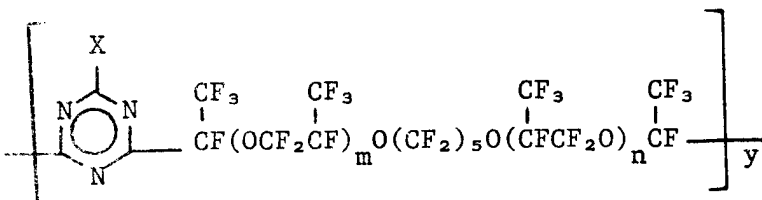

$$m + n = 6$$

$$\text{X} = \text{CF}_3 \text{ (70\%), } (\text{CF}_2)_3\text{CN (30\%)}$$

$$= \text{CF}_3 \text{ (85\%), } (\text{CF}_2)_3\text{CN (15\%)}$$

DISCUSSION OF SLIDE X

In search for thermally-oxidatively stable sealants, perfluoro-alkylene ether dinitriles were prepared and converted to fluoropolymers by reaction through the CN group (trimerization \rightarrow triazines, reaction with $-CNO \rightarrow$ oxadiazoles). It was hypothesized that analogous reactions with acetylenic functional groups would yield material which possesses similar thermal oxidative properties but would be superior in terms of hydrolytic stability. Our experimentation leading to the preparation of highly fluorinated acetylenes is discussed below.

To the best of our knowledge, highly fluorinated diacetylenes have not been reported in the literature. Routes to monoacetylenes (Haszeldine) have been reported; however, in general, these routes are multistep and might prove difficult to apply to the preparation of diacetylenes. Thus, we considered alternate, shorter, routes to these compounds as shown in the slide.

In the first sequence an acyl acetylene was preparable but in low yields. The SF_4 reaction was not attempted. In the second route it was determined that long chain perfluoroalkyl methyl ketones are difficult to isolate, due to their ease of dimerization, even under mild conditions. The third route seems most applicable to the preparation of fluorinated acetylenes.

SLIDE X

FLUORINATED ACETYLENES

Haszeldine (1952)

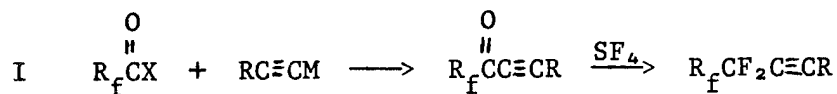
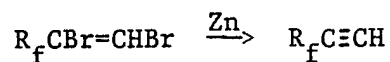
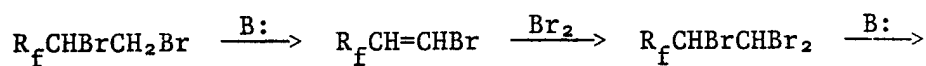
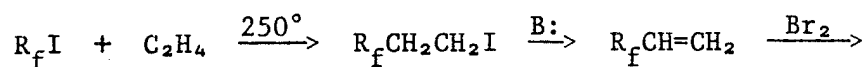

X = halogen

R = H, ϕ

M = MgX, Cu

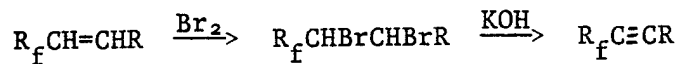
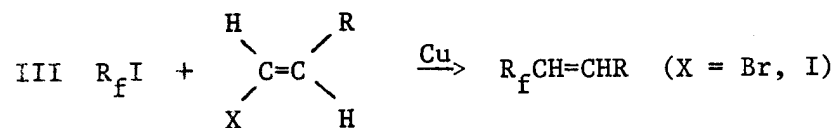
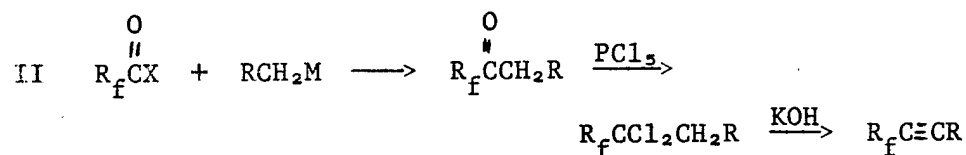

(R = ϕ)



(R = Cl)

DISCUSSION OF SLIDE XI

Perfluorovinyl compounds are prepared in good yield by copper coupling experiments in dipolar aprotic solvents (Burdon). We have observed that this reaction is not general; when the alkyl iodide has an α -oxygen substituent only degradation products occur. An oxygen atom β to the iodide affords the expected product smoothly. With regard to the iodide containing the α -oxygen substituent it is suspected that the organocopper reagent is initially formed, in keeping with reactions of this sort, and then decomposes to a perfluoroethyl copper species which then reacts to give the observed product.

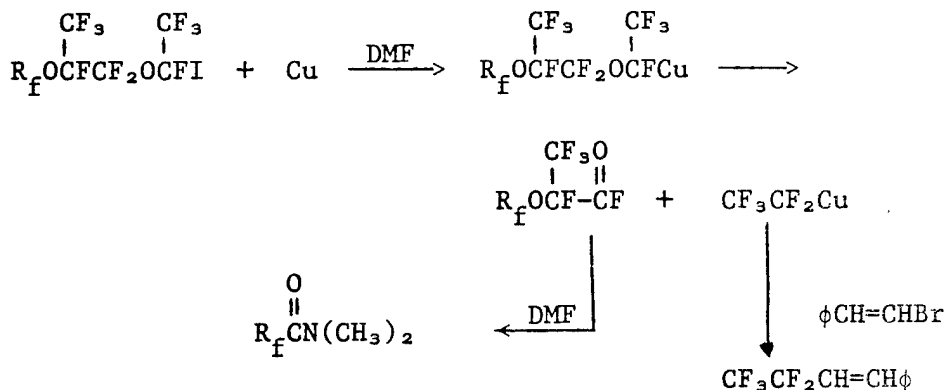

The reactions between the R_fI and vinyl halide seem stereospecific. Thus, an 80:20 mixture of trans and cis $\phi\text{CH}:\text{CHBr}$ yield roughly an 80:20 composition of trans:cis $\text{R}_f\text{CH}=\text{CH}\phi$, respectively. Reaction between either a 95:5 or 75:25 trans:cis composition of $\text{ICH}=\text{CHCl}$ and R_fI gives the expected $\text{R}_f\text{CH}=\text{CHCl}$ composition for a stereospecific reaction.

Compounds of the general structure $R_f\text{CH}=\text{CH}\phi$ brominate and dehydrohalogenate (KOH) smoothly. The end product, $R_f\text{C}\equiv\text{C}\phi$ is formed in yields ranging from 70-90% based on starting $\phi\text{CH}=\text{CHR}_f$. This route was successfully applied to the preparation of, to the best of our knowledge, the first fluorinated diacetylene, $\phi\text{C}\equiv\text{C}(\text{CF}_2)_6\text{C}\equiv\text{C}\phi$.

SLIDE XI

Route III

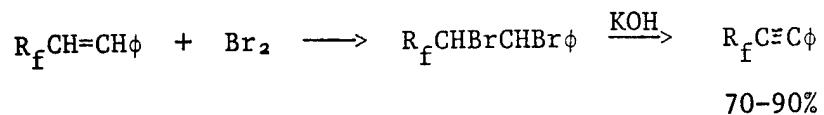
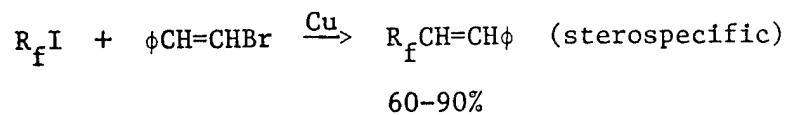

$R_f = C_7F_{15}, (CF_3)_2CFOCF_2CF_2$ or for diiodide

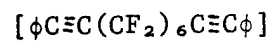

If $R_f = R_f CF_2 \overset{CF_3}{\underset{|}{O}CFI}$ get $CF_3 CF_2 C\equiv C\phi$, via decomposition of

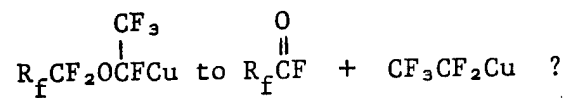

DISCUSSION OF SLIDE XII

Difficulties were encountered in dehydrohalogenating $R_fCH=CHCl$ (trans) compounds. The difficulty in elimination may be due to the cis geometry of the departing H and Cl substituents. This may account for the formation of R_fH as a major by-product in the KOH dehydrohalogenation, i.e., trans elimination of a positive chlorine (Cl^+) and negative R_f fragment (R_f^-).

The attempted preparation of $C_7F_{15}C\equiv CCF_3$ from $C_7F_{15}CH=CHCF_3$ (trans) via halogenation and dehydrohalogenation is instructive. The trans olefin is reluctant to brominate (hv, Vycor flask); only 15% dibromide is formed after one week. In contrast, chlorination proceeded readily in a static system in pyrex. An interesting series of compounds is formed on treatment of the dichloride with KOH. It is believed that the formation of $C_7F_{15}H$ and $C_7F_{15}C\equiv CH$ as major liquid products in this reaction is a consequence of the stereochemistry of chlorine addition and HCl elimination reactions.

Assuming a random trans or cis chlorine addition to the olefin and a random trans or cis mono elimination, four intermediate haloolefins would result (I - IV, slide).

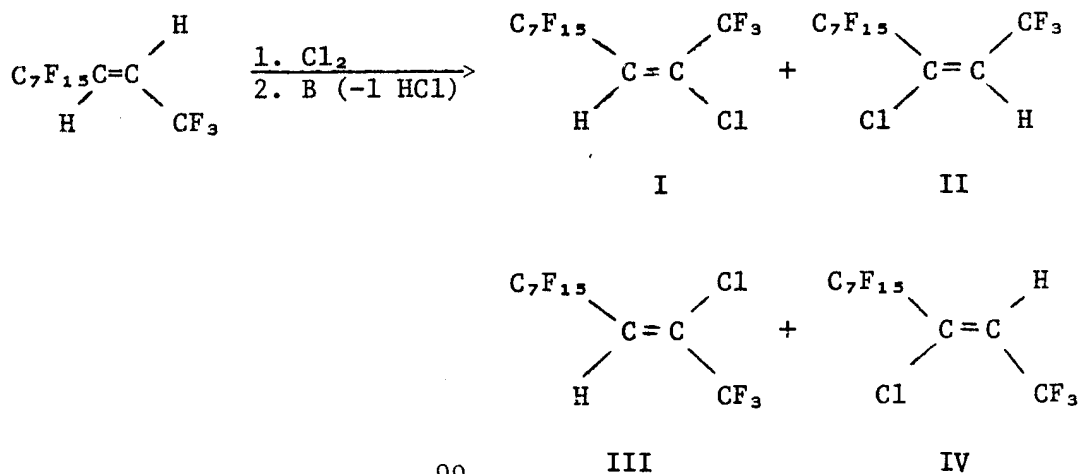

It is argued that the first two (cis R_f groups) would predominate over the last two (trans R_f groups) since they are formed by the most favored processes, i.e., trans addition of Cl_2 and trans elimination of HCl . Incidentally, both cis addition and cis elimination again forms the halo olefins with cis R_f groups. It then follows that $C_7F_{15}H$ could result from I via trans loss of Cl^+ (quite common in fluoroalkyl chemistry) and $C_7F_{15}^-$ by KOH treatment, and $C_7F_{15}C\equiv CH$ could be formed from II by similar loss of $Cl^+CF_3^-$.

Further substantiation of this route could be obtained by a gas analysis of the volatile products ($CF_3C\equiv CH$ and CF_3H).

Conventional H-Cl trans elimination from either III or IV could afford the $C_7F_{15}C\equiv CCF_3$ acetylene. If time allows, the stereochemistry of the Cl_2 addition and the HCl elimination (isolate I-IV) will be investigated.

If this explanation is found to hold for the scheme, the desired acetylene ($C_7F_{15}C\equiv CCF_3$) may be formed as the major product by starting with the cis olefin, $C_7F_{15}C=C$ $\begin{matrix} /CF_3 \\ /H \end{matrix}$, or isolating the trans haloolefins,

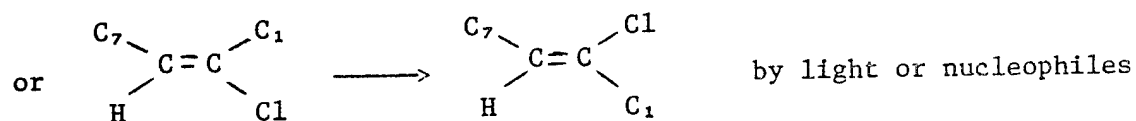
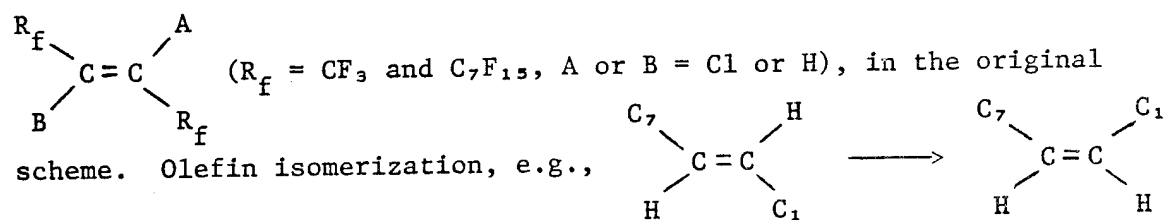

might yield the olefins of the appropriate geometry.

SLIDE XII

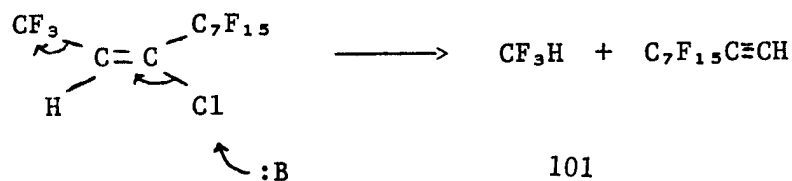
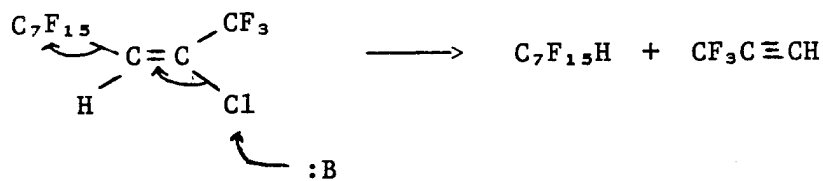
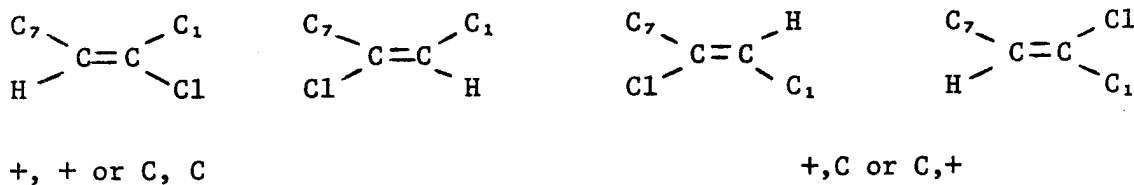
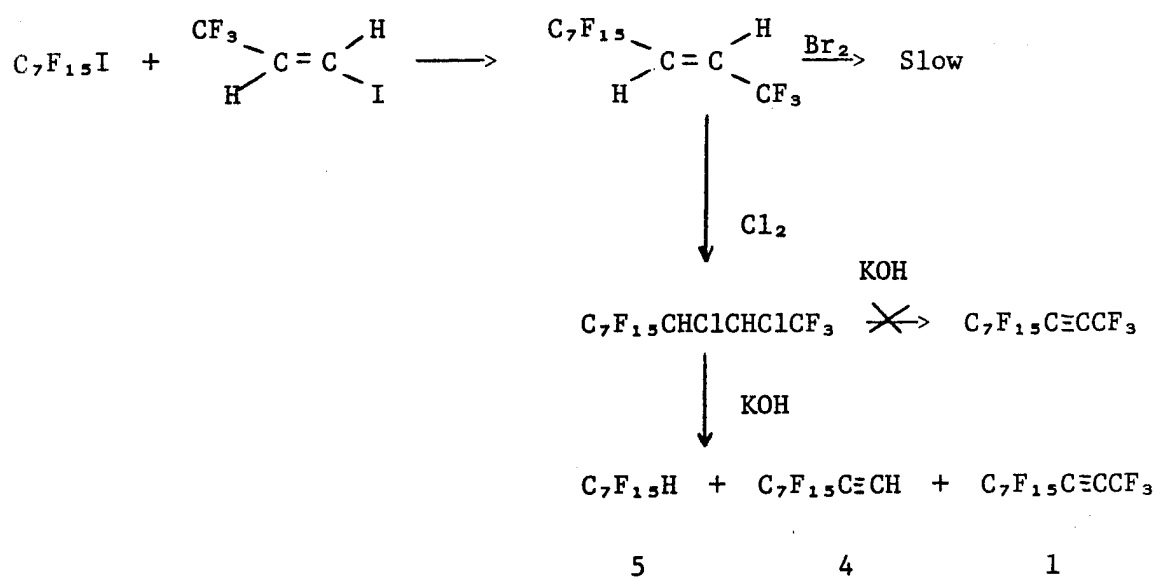
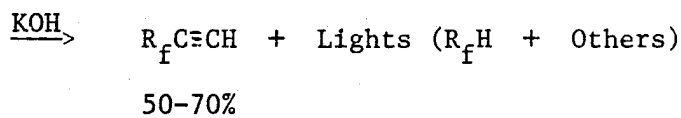
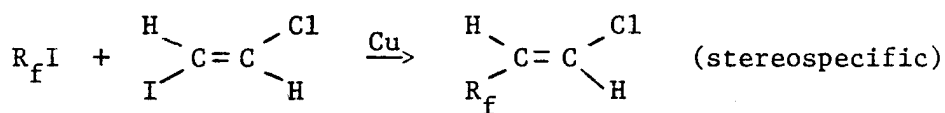

DISCUSSION OF SLIDE XIII

In order to ascertain the ability of fluorinated acetylenes to form cyclic products when reacted with a series of unsaturated substrates, reactions between an acetylene and a 1,3-dipole, diene, and reactive olefin were studied. The results are shown on the slide.

The above reactions are clean; unreacted starting material accounts for the remainder (>98%) of material balance.

SLIDE XIII

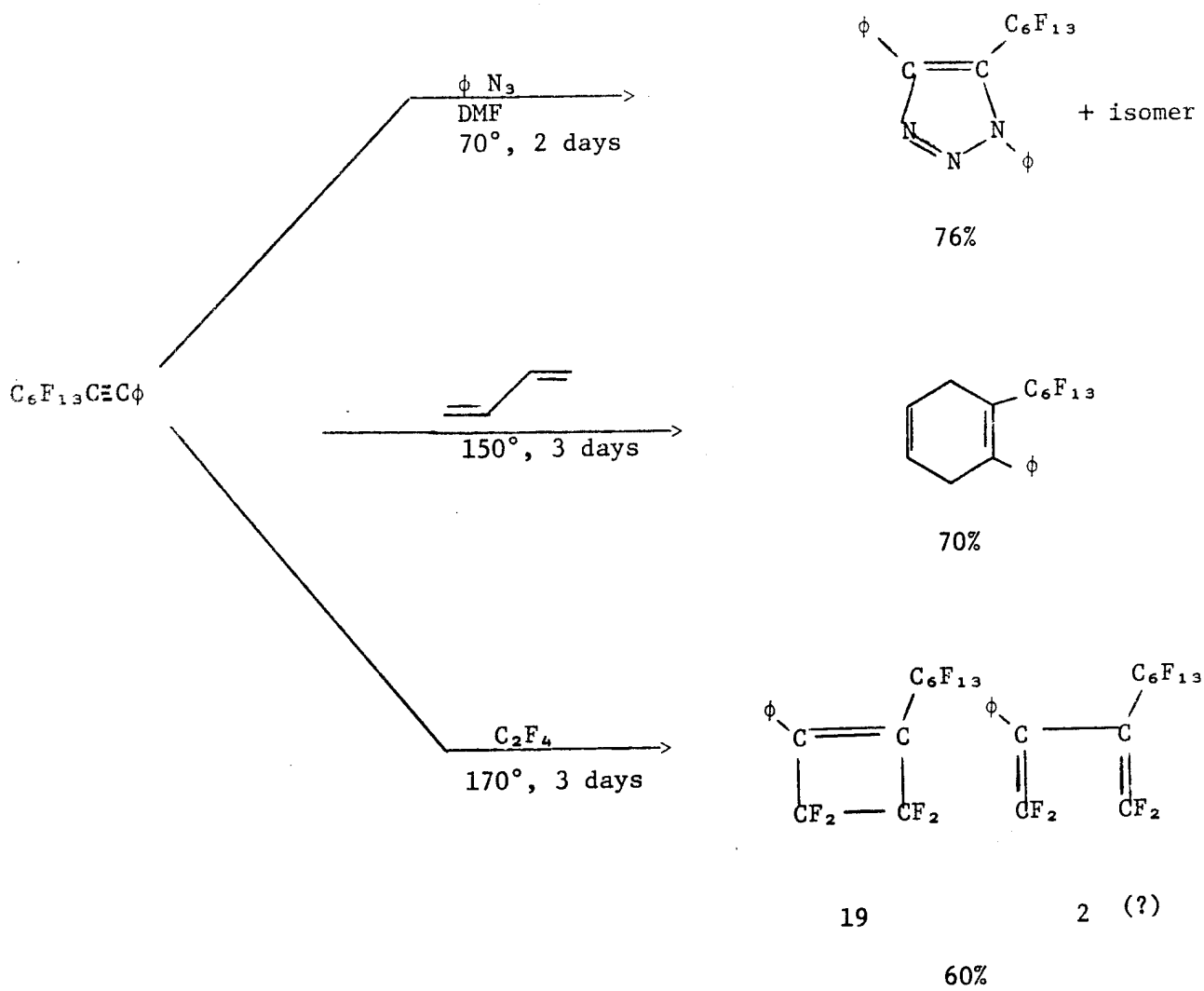

Clean, no other products

Unreacted starting material - material balance

DISCUSSION OF SLIDE XIV

Experimentation planned for the near future is outlined on the last slide.

SLIDE XIV

FUTURE WORK

1) Triazines

Pursue linear poly(imidoylamidine \rightarrow Triazine route incorporating pendent groups. (C_6F_5O , CN, $C\equiv CR$)

Then cross-link

2) Preparation of diacetylenes from HFPO EDAFs

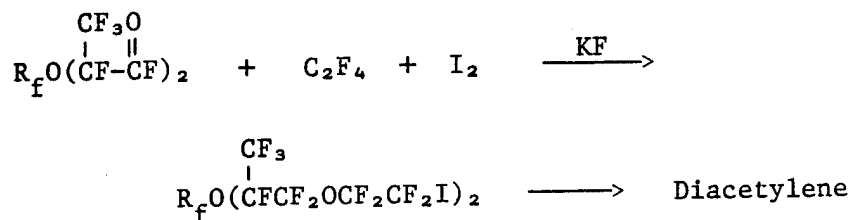

3) Copolymerize diacetylenes with

a) bis dienes, e.g.,

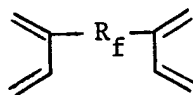

or

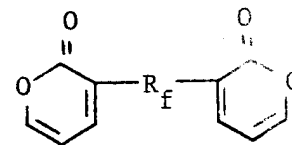

to give

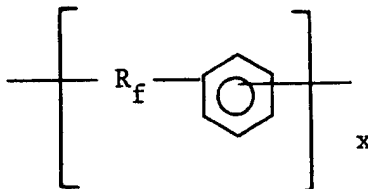

Systems

b) Bis 1,3-dipolar reactants, e.g., bis-nitrile oxides and imines, bis-tetrazoles, bis-azides, etc.

4) Prepare polyfunctional acid fluorides and convert to nitriles

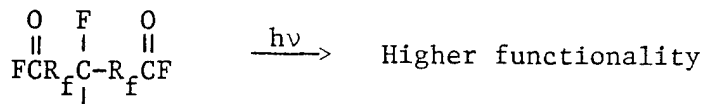
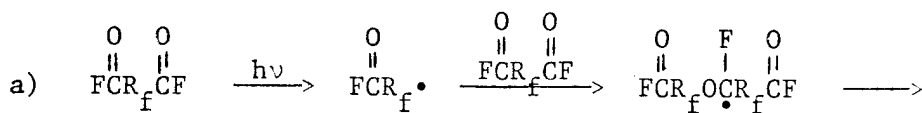

→ To nitriles for incorporation into polymerization schemes

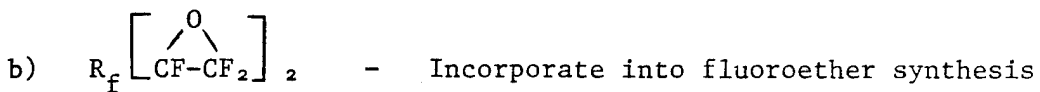

POLYPERFLUOROETHER-1,3,4-OXADIAZOLES AND 1,2,4,H-TRIAZOLES

D. D. Denson
Stanford Research Institute
Menlo Park, California 94025

Summary:

The synthesis and characterization of polyperfluoroether-1,3,4-oxadiazoles and 1,2,4,H-triazoles was undertaken as shown on Slide 1. 1,3,4-oxadiazoles containing a phenylene linkage were also prepared.

Slide 2 illustrates the first synthetic approach for the preparation of polyperfluoroether-1,3,4-oxadiazoles. An analogous approach was employed for the preparation of the poly-1,3,4-oxadiazoles containing a phenylene linkage as shown on Slide 3. Interfacial condensation and homogeneous solution polymerization methods were studied.

Slide 4 provides a summary of the conditions for these reactions.

Slide 5 illustrates an alternative route to polyperfluoroether-1,3,4-oxadiazole. This approach afforded the best polymeric materials.

Bulk polymerization techniques are applicable to this approach. A similar approach was employed for the synthesis of polyperfluoroether-1,2,4,H-triazoles and is shown on Slide 6.

Slide 7 provides a summary of the molecular weights Tga's and Tg's for the polymers prepared during this study.

POLY-1,3,4-OXADIAZOLES AND POLY-1,2,4,H-TRIAZOLES

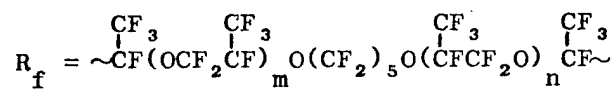
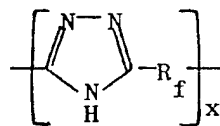
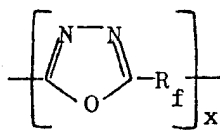
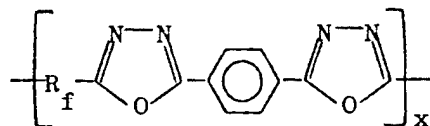

$$\bar{M}_n \approx 1500$$



Fig. 1

PREPARATION OF POLY-1,3,4-OXADIAZOLES

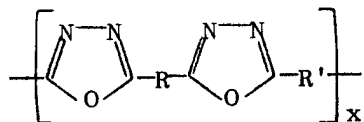
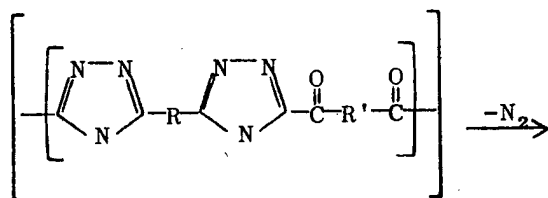
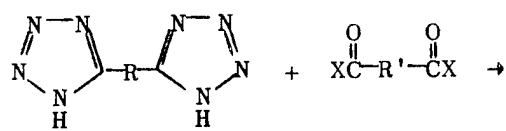

Fig. 2

PREPARATION OF POLY-PHENYLENEBIS-1,3,4-OXADIAZOLES

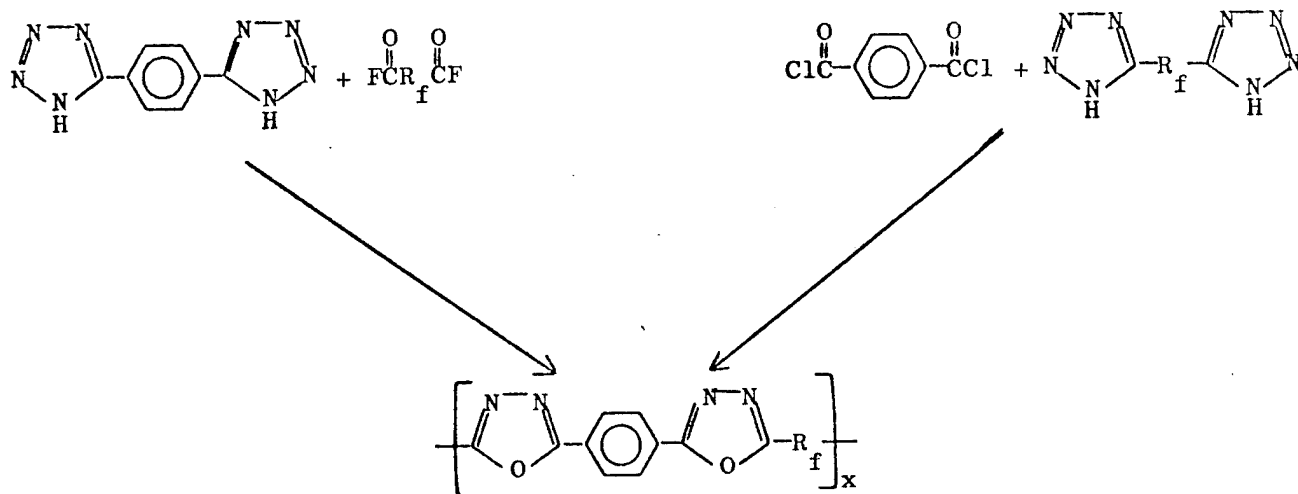
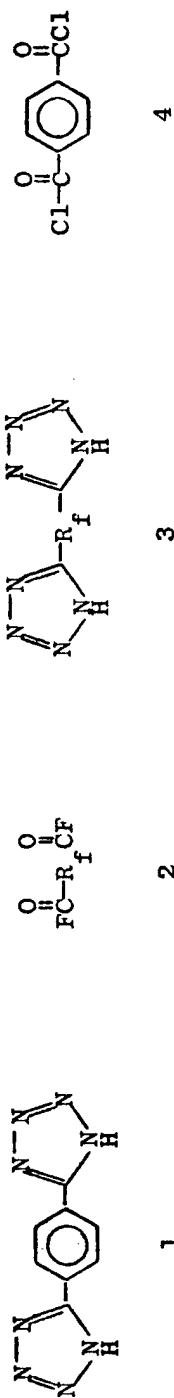

Fig. 3

REACTION CONDITIONS FOR PREPARATION OF POLY-1,3,4-OXADIAZOLES



Reaction	Molar Ratios	Solvent	Temp, °C	Time, hr
1 + 2	1:1	Pyridine/F112	100	24
1 + 2	1:1	DMF/F112	100	24
1 + 2	1:1	Pyridine/HFB	85	48
1 + 2	1:1	AcN	90	24
1 + 2	1:1	Pyridine/F112	100	72
3 + 4	1:1	AcN	90	72
3 + 4	1:1	DMF/F112	100	24
2 + 3	1:1	AcN/F112	95	72
2 + 3	1:1	HFB	85	48

Fig. 4



ALTERNATIVE SYNTHESIS OF POLY-1,3,4-OXADIAZOLES

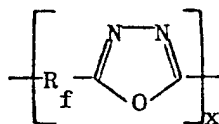
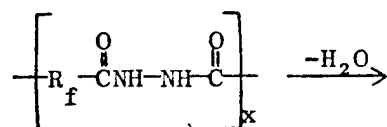
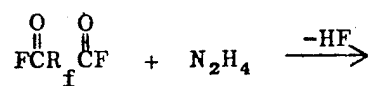

Fig. 5

SYNTHESIS OF POLY-1,2,4,5-H-TRIAZOLES

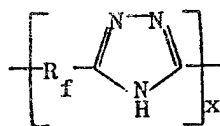
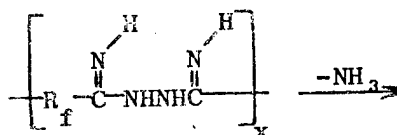
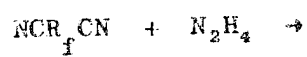

Fig. 6

SUMMARY OF POLYMER PROPERTIES

Polymer	Route	T_g	$T_d (\frac{1}{2})$	\bar{M}_n
		--	290°C	8K
	$\text{ClC} \text{---} \text{C}_6\text{H}_4 \text{---} \text{CCl} + \text{NCR}_f\text{CN} + \text{FCR}_f\text{COF}$	--	290°C	8K
		--	300°C	Low
	$\text{FCOR}_f\text{COF} + \text{N}_2\text{H}_4$	-18°C	300°C	8-310K
	$\text{NCR}_f\text{CN} + \text{N}_2\text{H}_4$	+13°C	425°C	--

Fig. 7



FLUOROETHER-1,2,4-OXADIAZOLE

L. O. Ross

Stanford Research Institute
Menlo Park, California 94025

Summary:

The synthesis of a high temperature stable elastomeric fluoroether-1,2,4-oxadiazole was accomplished by the reaction of terephthalonitrile and perfluorinated alkylether dinitrile (m.w. ~1500) at carbon tetrachloride reflux in 50% yield. (Slide 2). The by-products of the reaction were identified as dimerized terephthalonitrile endcapped with the perfluorinated alkylether dinitrile and trimerized terephthalonitrile endcapped with perfluorinated alkylether dinitrile (Slide 2). Mechanical and physical property data on the elastomer was excellent and is shown on Slide 5. Experiments designed to improve the yield of the elastomer are shown in Slide 3. In all cases, no elastomeric material was obtained.

Alternate preparations to fluoroether-1,2,4-oxadiazole via the reaction of terephthalamidoxime and the perfluoroalkylether diacidfluoride (m.w. ~1500) gave a low molecular weight oil, characterized as a perfluoroalkylether-1,2,4-oxadiazole (Slide 4). Varying the reaction conditions did not provide a high molecular weight elastomer.

Preparation of a perfluoroalkylether-1,2,4-oxadiazole that did not contain an aromatic group was also attempted (Slide 4). The preparation involved the reaction of a perfluorinated alkylether diamidoxime (m.w. ~1500) with a perfluorinated alkylether diacidfluoride at ambient temperatures. The product was a low molecular weight oil.

Future work using the Rheovibron and gel permeation chromatography in Freon solvents was presented with the intent of using these techniques in a follow-on project.

Approaches:

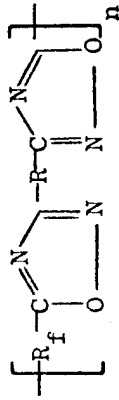
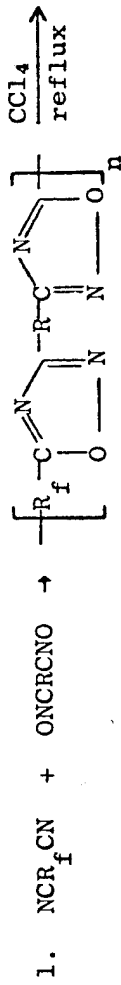

R_f = perfluoroalkylether



Ref. Robert Rosser, NASA-Ames, Moffett Field, California

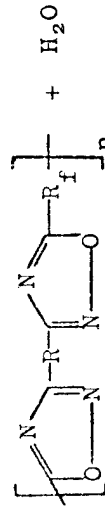
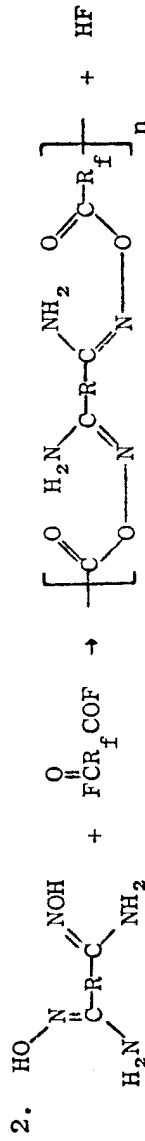

Ref. H. C. Brown, Polymer Preprints, 5, 243 (1964).

Slide 2

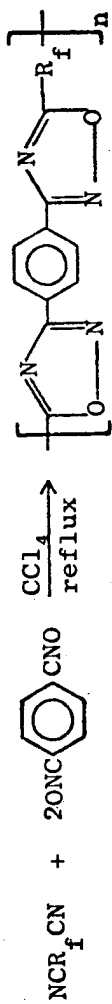

soluble in Freon 112

50% yield

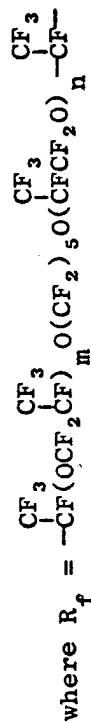

average molecular weight = 1443

- $m + n = 5$ 4.5%
- $m + n = 6$ 81.0%
- $m + n = 7$ 14.5%

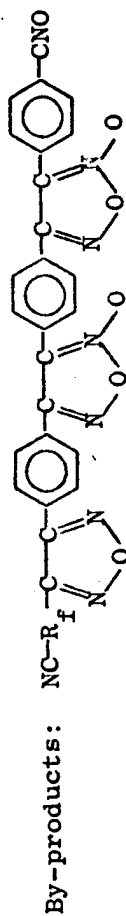

20% yield

insoluble in Freon 112

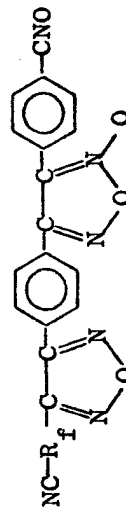

17% yield

soluble in CCl_4



Slide 3

Experiment	Reactants	Conditions/Solvent	Products
1	NCR CN + p-ONC ϕ NCO	Freon 112/reflux 24 hrs	Low molecular weight polymer and polybis- furanan N-oxide
2	NCR CN + p-ONC ϕ NCO	55° DMF/Freon TF 24 hrs	Low molecular weight polymer
3	NCR CN + p-ONC ϕ NCO	110° DMF/Freon 112 24 hrs	Low molecular weight polymer
4	NCR CN + p-ONC ϕ NCO	DMF (reflux) 24 hrs	Low molecular weight oils
5	NCR CN + p-ONC ϕ NCO	110° Freon 112/ BF ₃ (etherate)	Polybisfuranan N-oxide and starting dinitrile



Slide 5

PHYSICAL AND MECHANICAL PROPERTY DATA

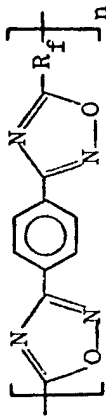

Tga (nitrogen): heat rate = 5.06°/min weight loss: 5% at 393°C
50% at 435°C
70% at 445°C
100% at 500°C

Tg = -43°C and -13°C

Molecular weight >20K

Maximum elongation >1300

Maximum tensile strength = 28.75 psi



STUDY OF CROSSLINKING AND DEGRADATION MECHANISMS
IN MODEL SEALANT CANDIDATES

K. L. Paciorek, R. H. Kratzer, and J. Kaufman
Ultrasystems, Inc., 2400 Michelson Drive, Irvine, Ca. 92664

The objective of this investigation was to determine on specific model compounds the relative thermal, thermal oxidative, and hydrolytic stability of potential crosslinks useful for curing perfluoroalkylether elastomers. Two heterocyclic ring systems were studied, namely triazines, and 1,2,4-oxadiazoles.

Five compounds, n-perfluoroheptyl-s-triazine, a perfluoroether substituted triazine, $[C_3F_7OCF(CF_3)CF_2OCF(CF_3)]_3C_3N_3$, 1,4-[bis-(5-n-perfluoroheptyl)-1,2,4-oxadiazolyl]-benzene, its perfluoroalkylether substituted analogue, and 3,5-bis(n-perfluoroheptyl)-1,2,4-oxadiazole were synthesized and characterized. To eliminate the effect due to a tertiary fluorine present in branched materials, the pure n-compounds were prepared. The n-perfluorooctanonitrile was obtained from n-perfluorooctanoic acid via the sequence shown below in an overall yield of 83%

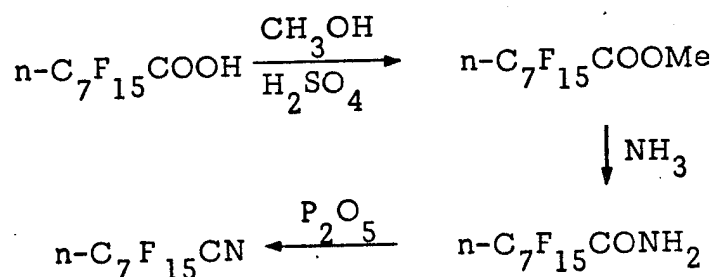

Heating of the n-perfluorooctanonitrile at 190°C in a sealed tube with 5 mole percent of silver oxide gave the n-perfluoroheptyl triazine in 84% yield, mp 27-29°C. Using the same technique the perfluoroether triazine $[C_3F_7OCF(CF_3)CF_2OCF(CF_3)]_3C_3N_3$, bp 101-104°C/0.001 mm, was afforded in 78% yield from the respective nitrile.

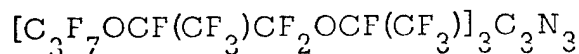
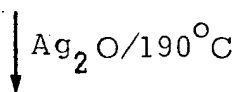
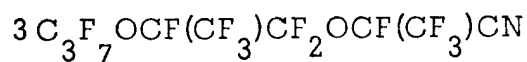
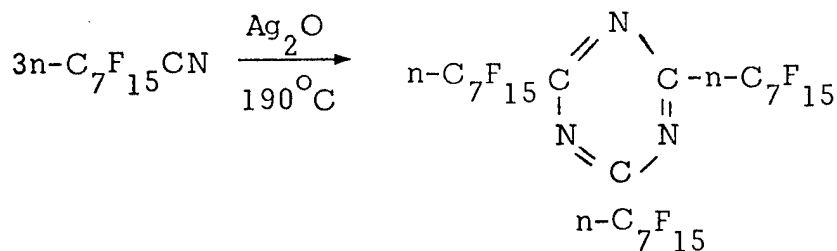

In Figures 1 and 2 are presented the respective DTA curves of the two compounds. It should be noted that the triazine synthesis using silver oxide catalysis (E. Dorfman and W. E. Emerson, "Perfluoroalkylenetriazine Elastomeric Polymers", ML-TDR-64-249, Part II (1965)) appeared to be less tedious and gave better yields of the desired products than the amidine route.

3,5-Bis(n-perfluoroheptyl)-1,2,4-oxadiazole, mp 27-28°C, was synthesized following the procedure of H. C. Brown and C. R. Wetzel: (J. Org. Chem., 30, 3734 (1965))

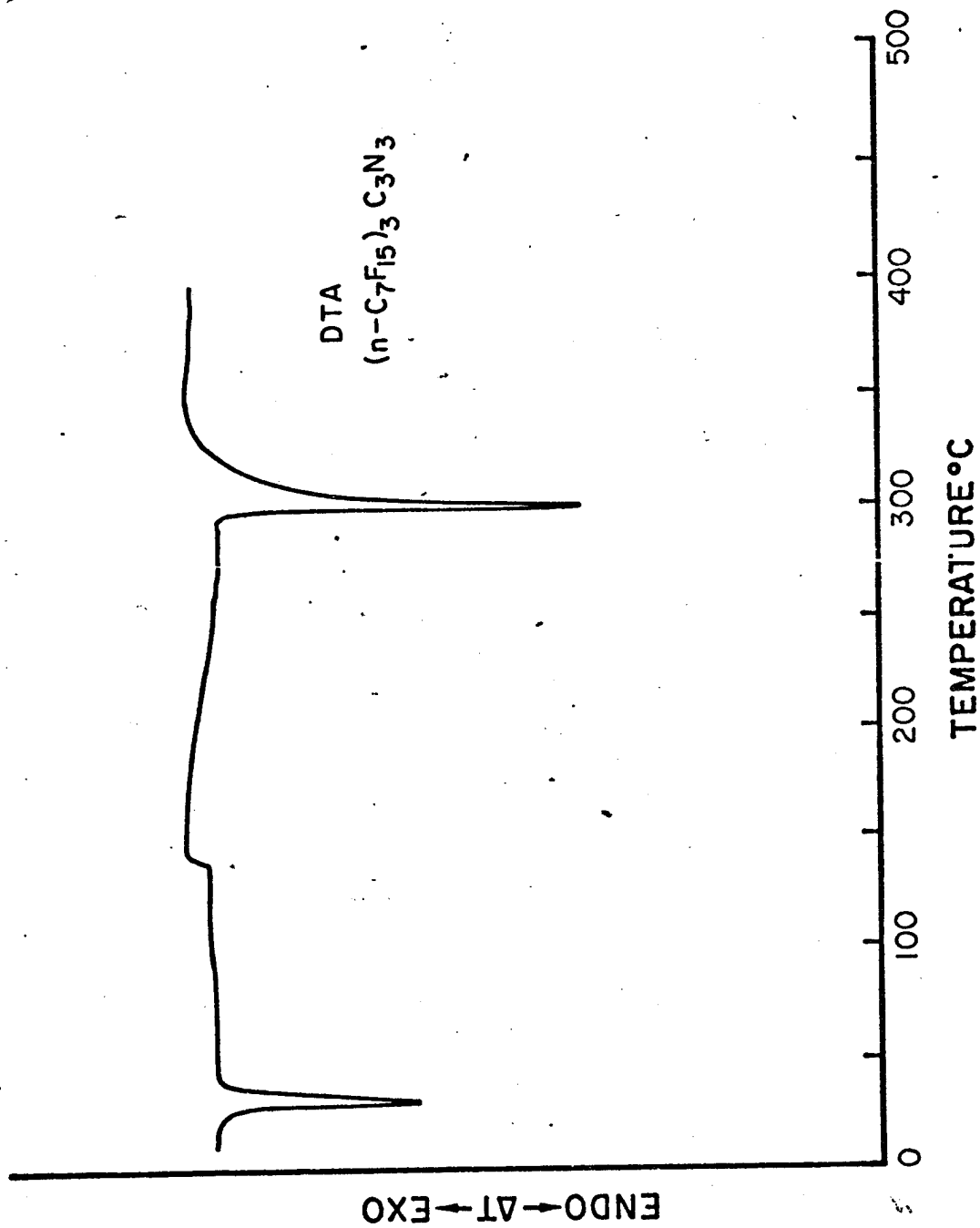

Fig. 1 DTA of $(n-C_7F_{15})_3C_3N_3$

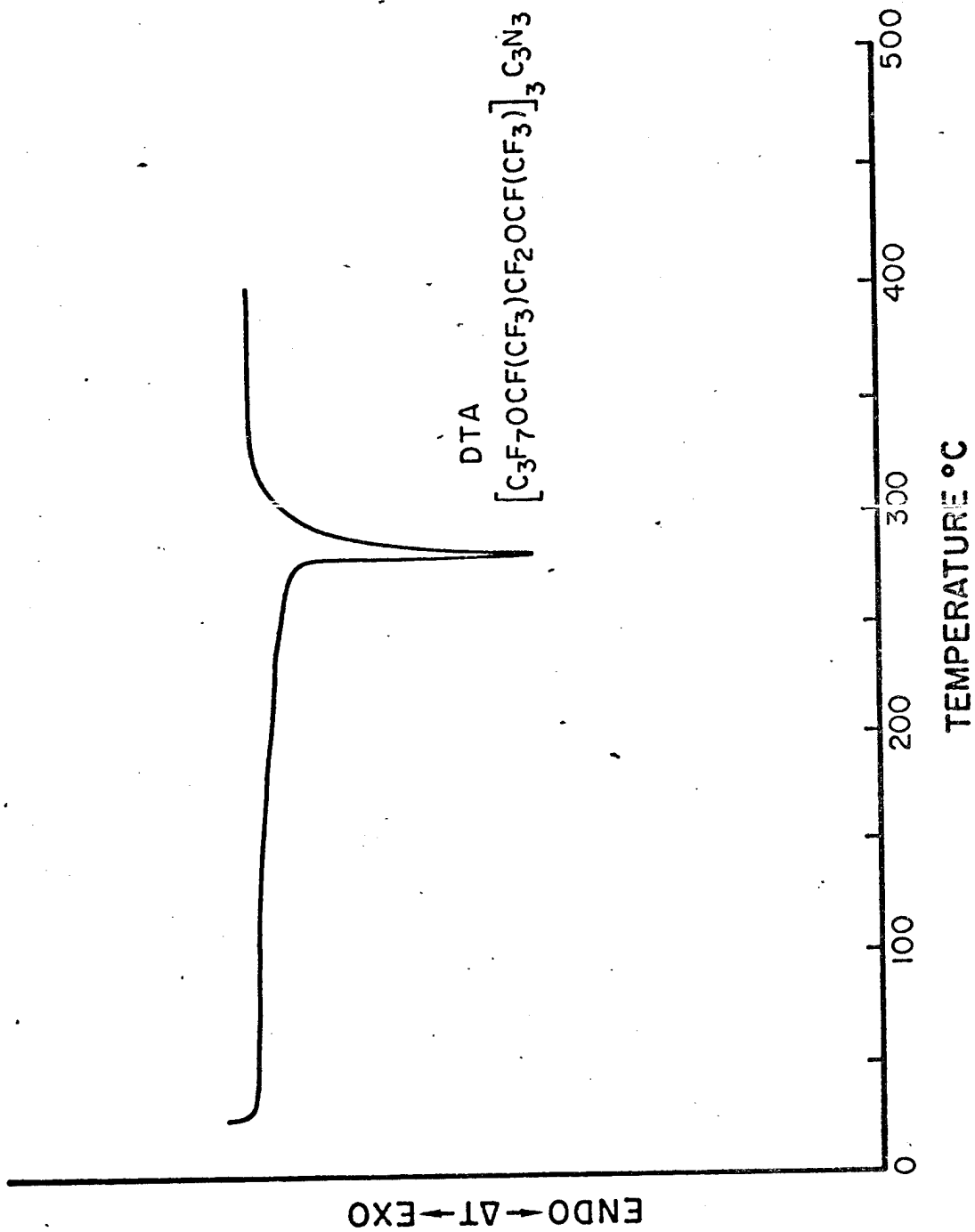
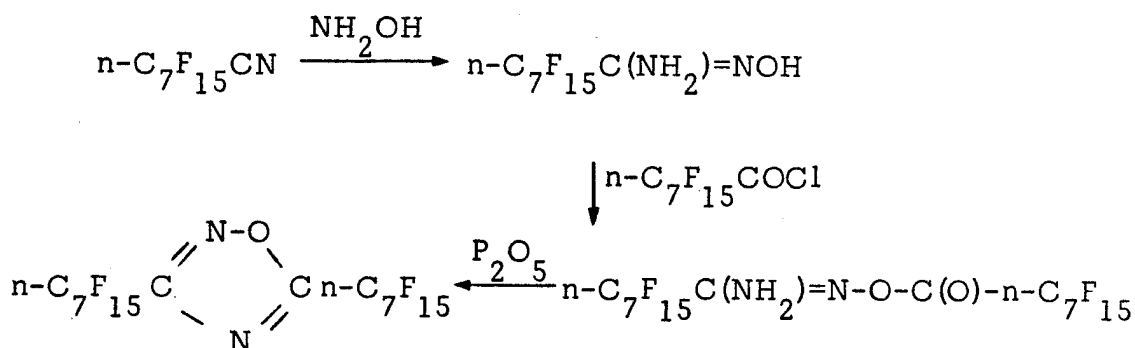

Fig. 2 DTA of $[C_3F_7OCF(CF_3)CF_2OCF(CF_3)]_3C_3N_3$



in an overall yield of 46%. The differential thermal analysis curve of this material is given in Figure 3.

To determine the optimum reaction conditions for the preparation of 1,2,4-oxadiazoles from the interaction of terephthalonitrile-bis-N-oxide and the given perfluorinated nitrile the DTA of the mixtures were determined (see Figures 4 and 5).

Interaction of terephthalonitrile-bis-N-oxide (received from Hughes Aircraft Company) with an excess of n-perfluorooctanonitrile at 50-57°C gave 1,4-[bis-(5-n-perfluoroheptyl)-1,2,4-oxadiazolyl]-benzene, mp 127-128°C, in 78% yield. In a similar manner the perfluoroalkylether substituted terephthalonitrile-bis-N-oxide derived oxadiazole was prepared. The reaction was carried out at 85-90°C; the product, bp 140-142°C/0.001 mm, was obtained in 62% yield. As indicated above the optimum reaction temperature was determined from a DTA curve of the mixture of the two components. It should be noted that in view of the thermal instability of terephthalonitrile-bis-N-oxide and the relatively non-reactive nature of the perfluoroalkylether nitrile the range for the reaction temperature is very narrow.

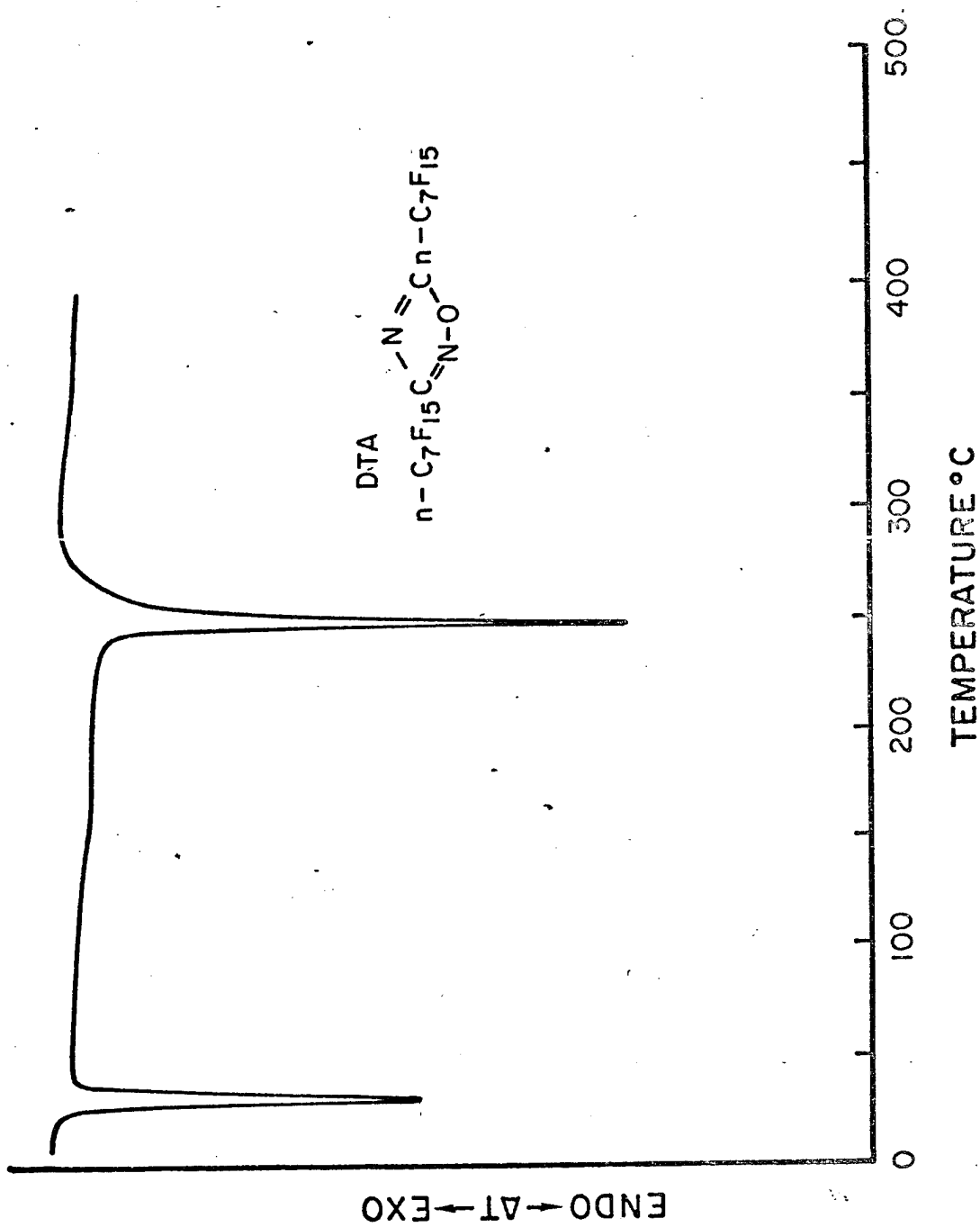

Fig. 3 DTA of 3,5-bis(perfluoroheptyl)-1,2,4-oxadiazole

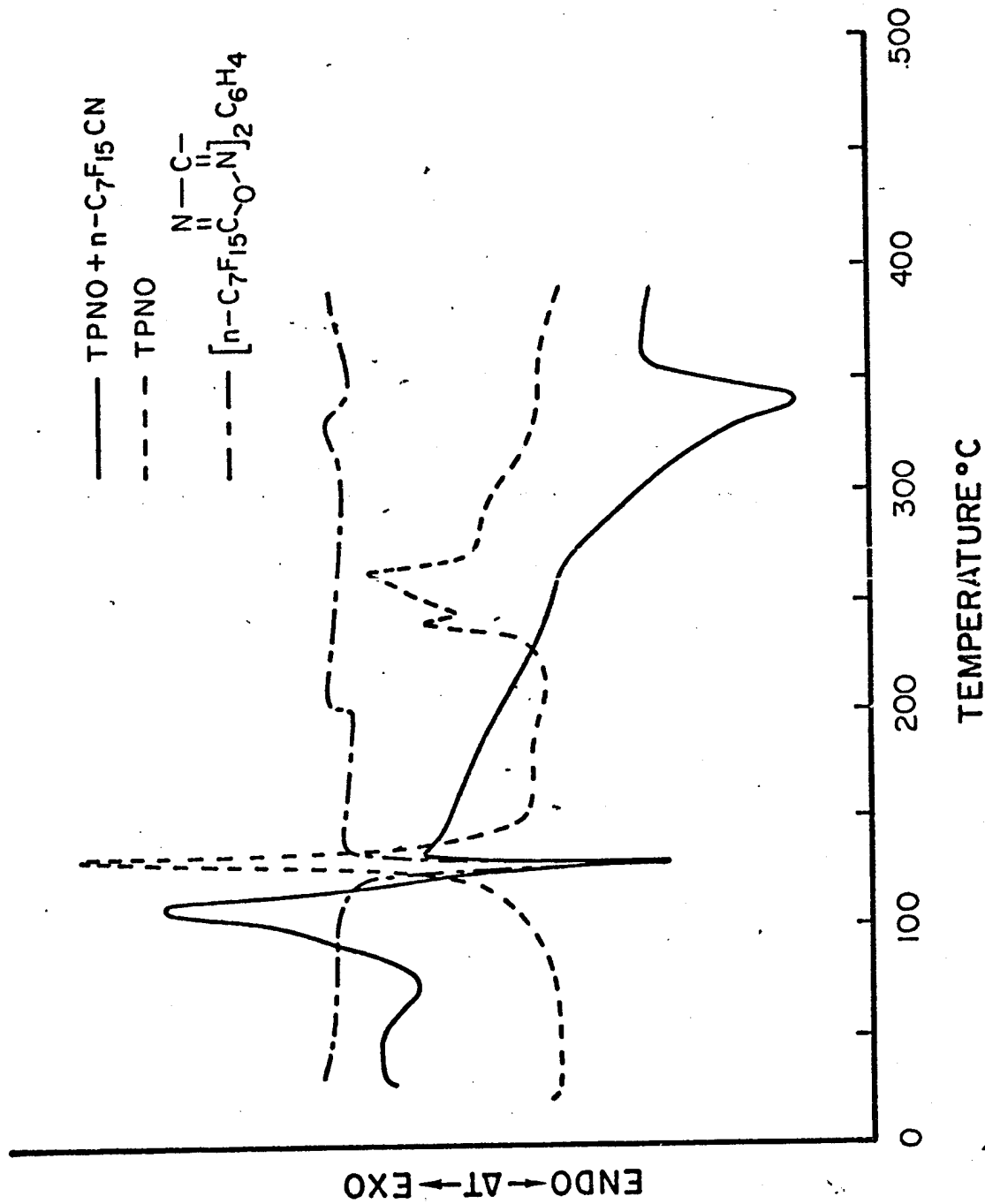

Fig. 4 DTA curves of terephthalonitrile-bis-oxide -- n-octanonitrile system

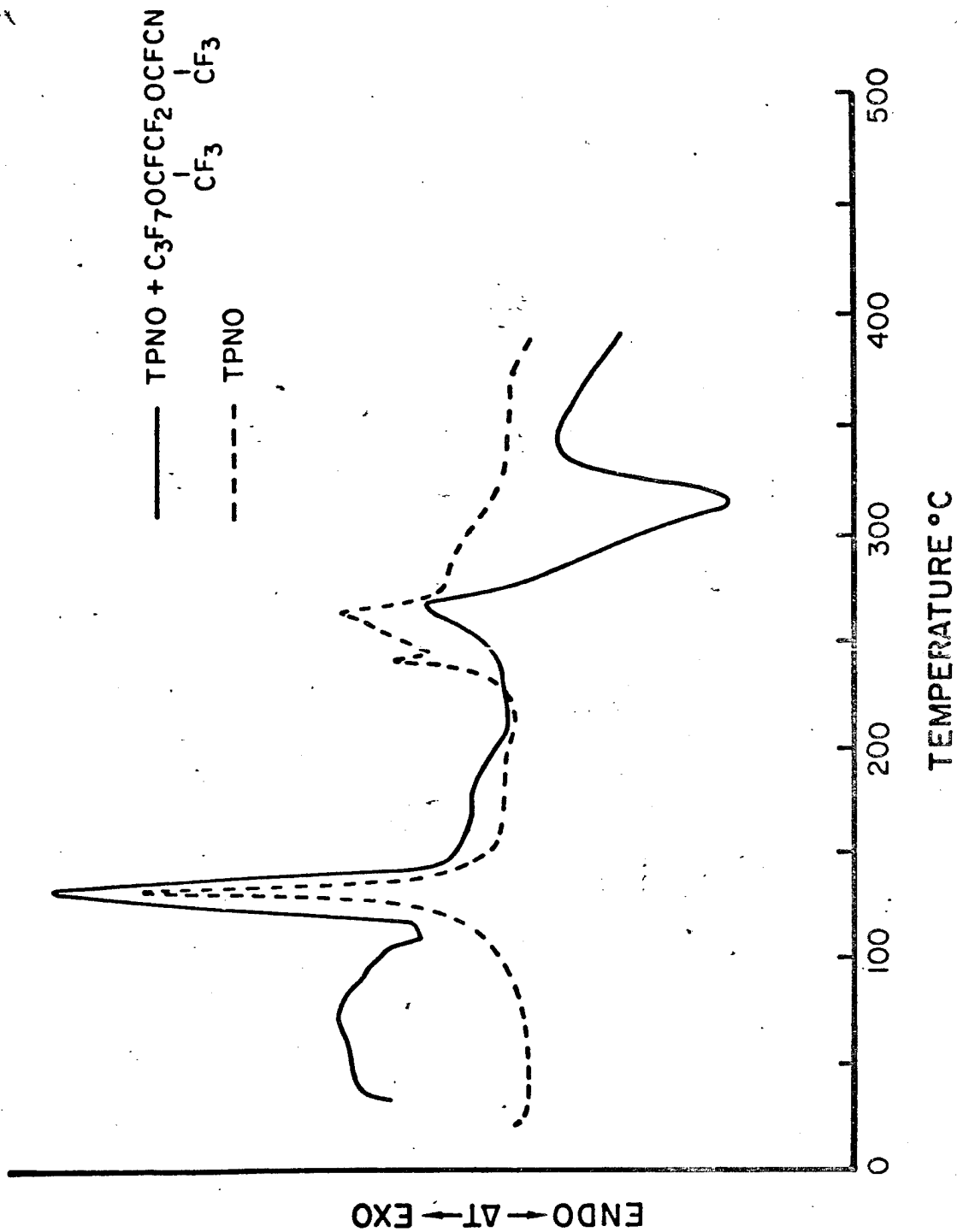
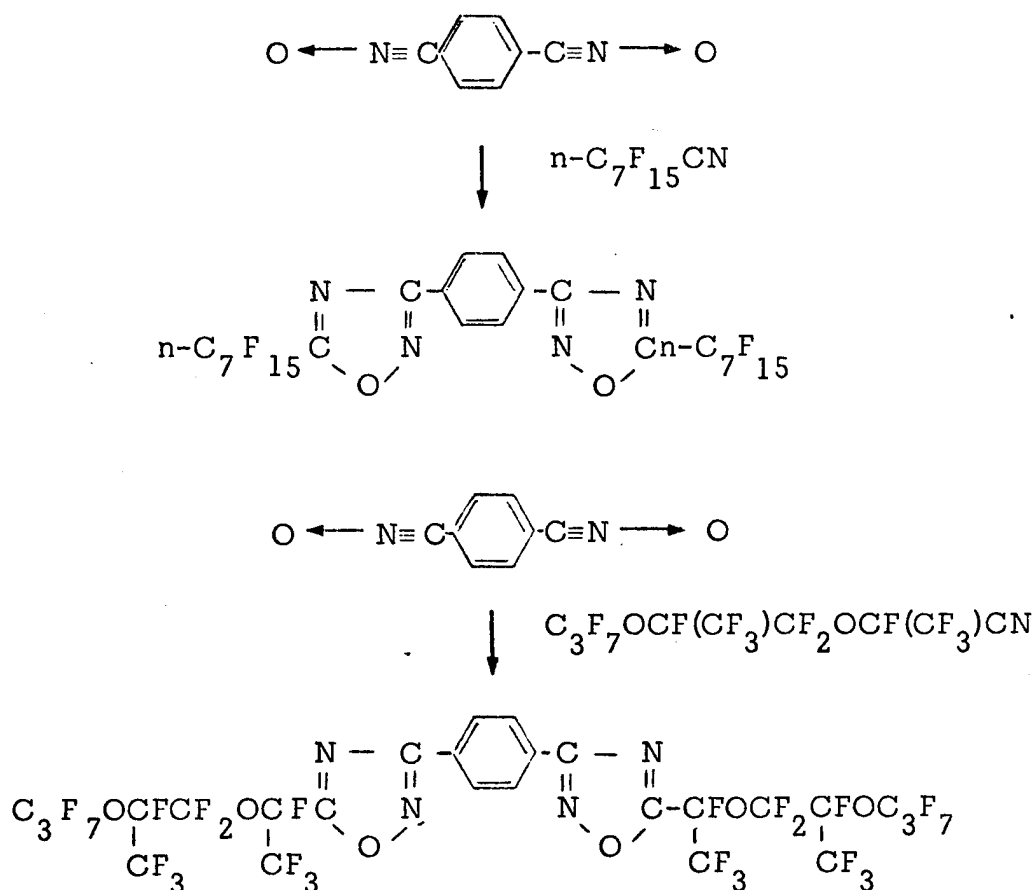

Fig. 5 DTA curves of terephthalonitrile-bis-oxide-r-perfluoroalkylether nitrile system



The fact that the melting point is lowered by the perfluoroalkylether group is apparent in comparison of the physical properties of the two oxadiazoles. Thus the perfluoroheptyl substituted material is a high melting solid whereas the perfluoroalkylether derived compound is a liquid at room temperature (see Figures 4 and 6).

The degradation investigations were performed in sealed ampoules of ca 50 ml volume over a period of 48 hr at 235 and 325^oC. The media studied were nitrogen, air, and nitrogen/water. The quantities of material employed were between 0.5-1.0 g, whereas the gas pressures used were ca 350 mm at room temperature. In the experiments involving water, it was weighed into the ampoules. At the conclusion of an experiment the ampoules

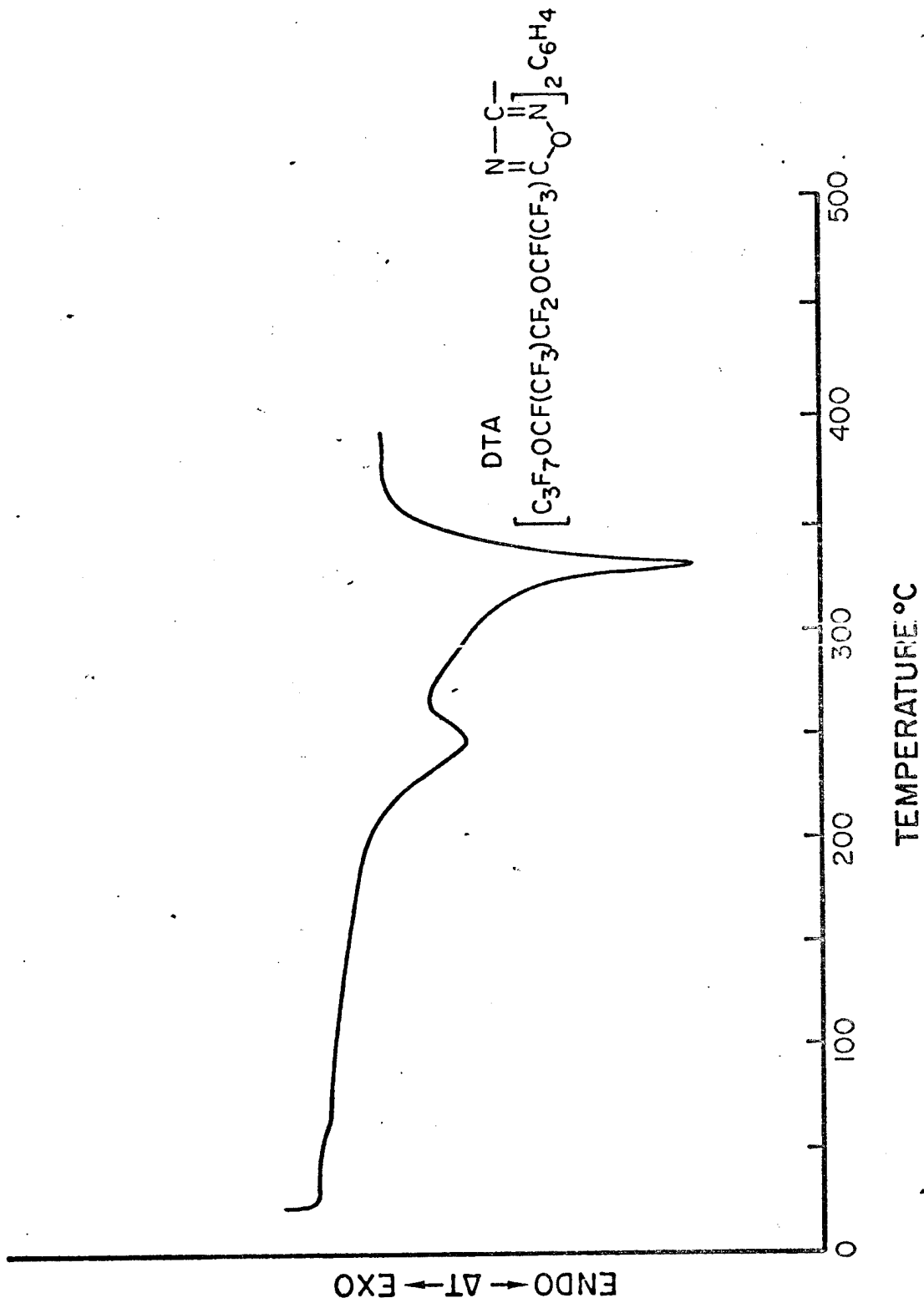

Fig. 6 DTA of perfluoroalkylether substituted 1,2,4-oxadiazole

were cooled in liquid nitrogen and were opened into the vacuum system. The noncondensibles were measured and determined by mass spectrometry. The liquid nitrogen condensibles which were volatile at room temperature were fractionated from a warming trap through -23 , -78°C into a liquid nitrogen cooled trap. Each fraction was measured, weighed, and analyzed by infrared spectroscopy and mass spectrometry. The residue itself was weighed and subjected to gas chromatography, infrared and mass spectral analyses, and DTA.

The tris-*n*-perfluoroheptyl-*s*-triazine was recovered quantitatively unchanged in nitrogen at 235 and 325°C and in air at 235°C (no oxygen depletion occurred). In air at 325°C 98.3% of the starting material was recovered unchanged, however, 88% (4.3 mg) of the available oxygen was used up. Thus it could be deduced that in the presence of additional air (oxygen) more extensive decomposition would have taken place. Conducting the test at 235°C in nitrogen/water resulted in complete transformation of the triazine. No starting material was recovered. The infrared spectrum of the residue indicated pure $n\text{-C}_7\text{F}_{15}\text{CONH}_2$, however the DTA curve showed an additional endotherm at ca 85°C (compare Figures 7 and 8). Among the condensible volatiles CO_2 and fluorinated hydrocarbons were found. These results are summarized in Table I.

The formation of SiF_4 and to a degree CO_2 is most likely due to reaction of the active fluorinated species, possibly R_fCOF , with the ampoule walls. In all the decomposition studies fluorinated hydrocarbons were observed; in some instances in just trace quantities. In the fully fluorinated materials no hydrogen is present, however some hydrogen is available from the Si-OH entities in the ampoule walls.

The perfluoroalkylether triazine (See Table II) was recovered unchanged (99.4%) from the treatment in nitrogen, air, and nitrogen/water at 235°C . At 325°C in air it underwent ca 1.5% degradation (37% of the

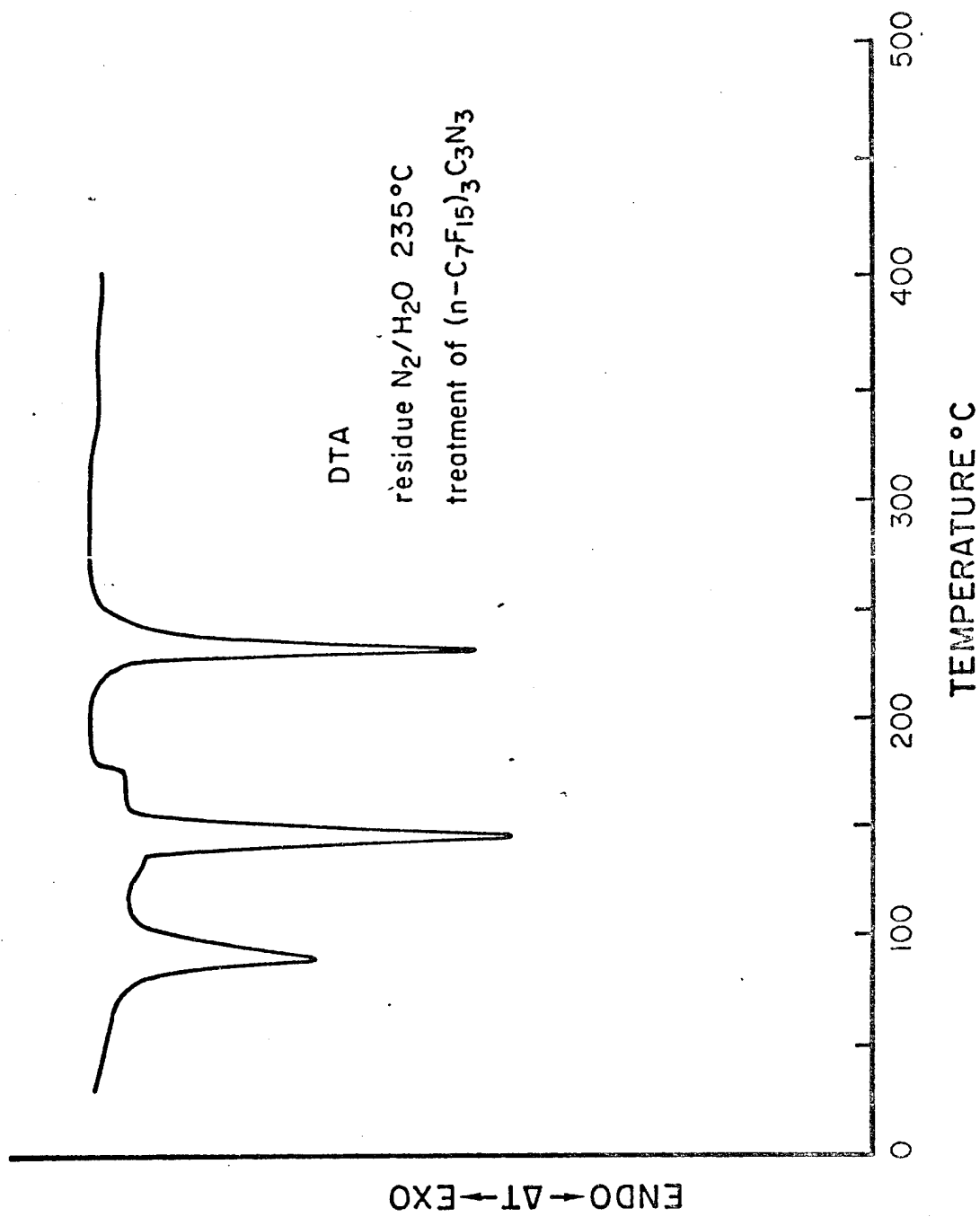

Fig. 7 DTA of the residue N₂/H₂O 235°C treatment of n-perfluoroheptyl-s-triazine

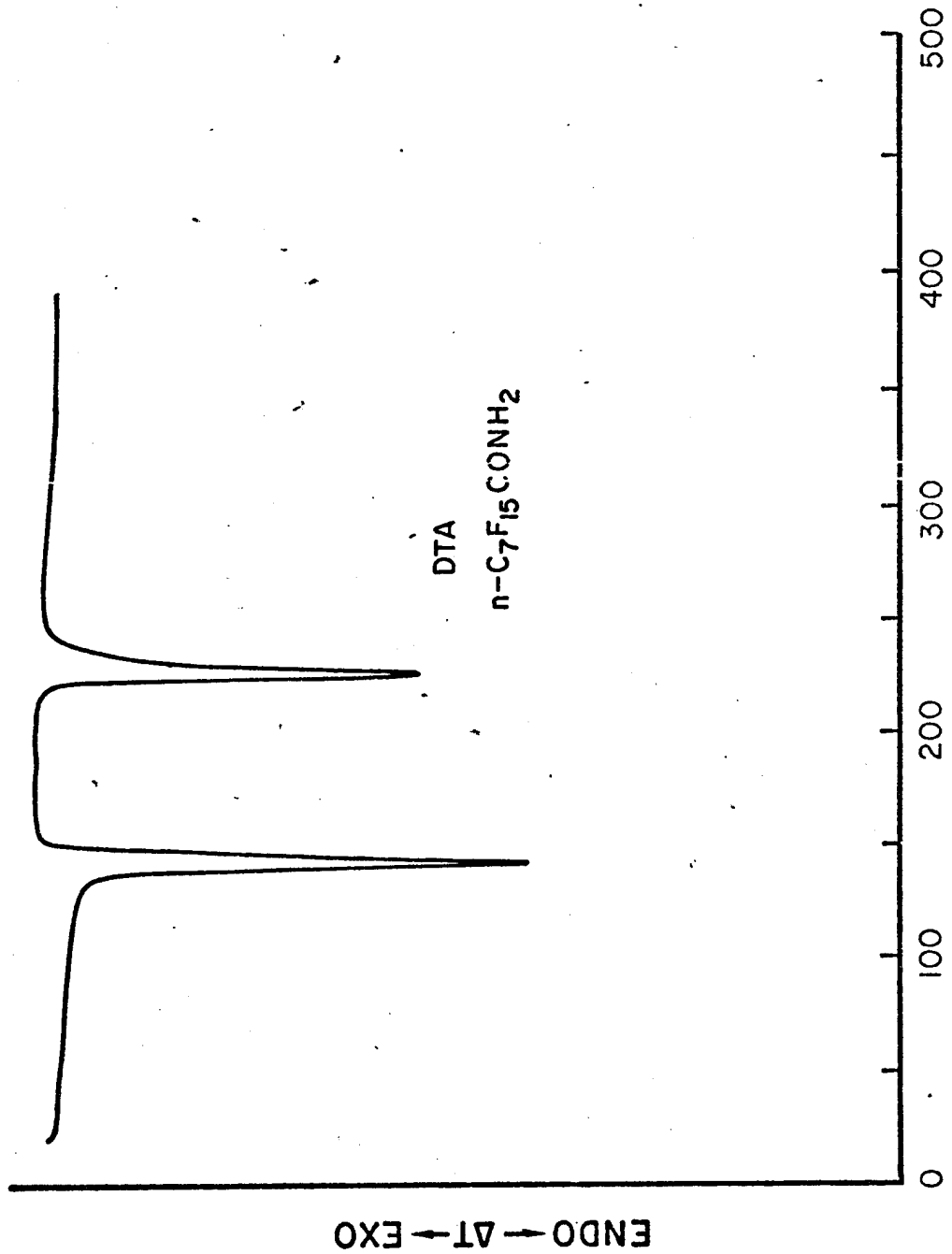

Fig. 8 DTA of n-perfluorooctanamide

TABLE I
 DEGRADATION OF
 $(n-C_7F_{15})_3C_3N_3$

Temp °C	Atm	SM ^a %	Volatiles Formed							
			SiF ₄		CO ₂		CO		R _f CN % ^d	Other mg
			mg	% ^b	mg	% ^c	mg	% ^c		
235	Air	100	0.34	0.03	1.10	0.11	-	-	-	-
235	N ₂ /H ₂ O ^e	none	-	-	10.77	1.18	-	-	-	344.7
325	N ₂	99.8	0.25	0.02	0.72	0.08	-	-	0.16	-
325	Air	98.3	10.35	1.04	16.02	1.79	0.15	0.03	0.21	3.0

a In all these degradations a 1-g sample of material was employed; the percent given is that of starting material recovered.

b Percent of total fluorine present.

c Percent of total carbon present.

d Percent of starting material.

e The water employed was 101.0 mg (5.606 mmol). The involatile residue amounted to 763.7 mg assuming it to be $n-C_7F_{15}CONH_2$, this corresponds to 59.9% of the triazine used; the 344.7 mg include some water and fluorinated hydrocarbons.

TABLE II
DEGRADATION OF

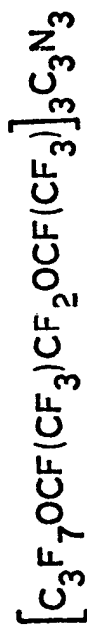

Temp °C	Atm	SM ^a %	Volatiles Formed							
			SiF ₄		CO ₂		CO		R _f CN ^d %	Other mg
			mg	% ^b	mg	% ^c	mg	% ^c		
235	Air	99.6	1.12	0.11	2.07	0.23	0.06	0.01	-	1.0
235	N ₂ /H ₂ O ^e	99.4	-	-	0.86	0.10	-	-	-	99.5
325	N ₂	98.9	1.80	0.19	1.82	0.22	0.20	0.04	T	5.0
325	Air	98.5	6.4	0.69	8.60	1.03	0.69	0.13	T	0.1

a In all these degradations a 1-g sample of material was employed; the percent given is that of the starting material recovered.

b Percent of total fluorine present.

c Percent of total carbon present.

d Percent of starting material.

e The water employed was 103.9 mg (5.767 mmol); the 99.5 mg recovered in volatiles was mainly water plus traces of fluorinated hydrocarbons.

available oxygen was depleted) the main products formed were CO_2 , SiF_4 , and CO ; traces of nitrile and compounds $[\text{R}_f\text{CO}]_2\text{O}$ and R_fCOF were also detected.

The 3,5-bis-n-perfluoroheptyl-1,2,4-oxadiazole exhibited excellent thermal, thermal oxidative, and hydrolytic stability as obvious from the data given in Table III.

Both of the hydrogen containing oxadiazoles decomposed extensively in air and nitrogen at 325°C . The data are summarized in Tables IV and V. No starting material was recovered from the air studies at 325°C ; all the oxygen present was depleted. The n-perfluoroheptyl substituted oxadiazole was oxidatively (at 235°C , in air) somewhat less stable than the perfluoroalkylether oxadiazole, i.e., 94.7 versus 99.5% of starting material recovered. Furthermore the oxygen depletion at 235°C was ca 3% for the perfluoroalkylether oxadiazole whereas in the case of the perfluoroalkyl substituted material it amounted to 51%. In nitrogen/water at 235°C the hydrogen-containing oxadiazoles were recovered virtually unchanged; only small quantities of carbon dioxide and fluorinated hydrocarbons were formed.

The infrared spectra of all the TPNO derived 1,2,4-oxadiazole residues (after the 235°C treatments) exhibited weak absorptions at $5.72\ \mu$ (perfluoroalkylether substituted material) and at $5.80\ \mu$ (perfluoroalkyl substituted material). As can be seen from Tables IV and V both of the oxadiazoles afforded substantial quantities of the fluorinated nitriles on degradation. Thus it would seem that the low stability of these materials is due to dissociation. The infrared absorptions in the 5.70 - $5.80\ \mu$ region could very well be due to the amide formation from the reaction of the liberated nitrile with water. In the experiments where water was added this finding is readily explained; in the other tests water can be either formed by oxidation of CH entities or via the reaction of reactive species with ampoule walls. Inasmuch as the degree of decomposition for the perfluoroalkylether substituted oxadiazole

TABLE III
DEGRADATION OF

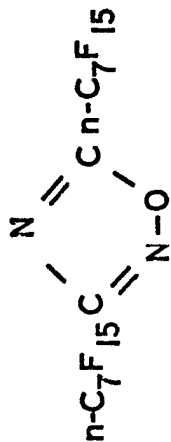

Temp °C	Atm	SM ^a %	Volatiles Formed							
			SiF ₄		CO ₂		CO		R _f CN %	Other mg
			mg	% ^b	mg	% ^c	mg	% ^c		
325	N ₂	99.7	T	T	0.32	0.05	-	-	-	0.3
325	Air	99.3	-	-	0.67	0.13	-	-	-	0.1
235	N ₂ /H ₂ O ^d	99.1	-	-	0.20	0.03	-	-	-	64.1
235	N ₂	99.5	-	-	-	-	-	-	-	-
235	Air	99.5	-	-	0.11	0.02	-	-	-	0.3

a In all these degradations a 0.6-0.7-g sample of material was employed; the percent given is that of the starting material recovered.

b Percent of total fluorine present.

c Percent of total carbon present.

d The water employed was 64.5 mg (3.580 mmol); the 64.1 mg recovered in volatiles was almost pure water with just traces of fluorinated hydrocarbons.

TABLE IV

DEGRADATION OF

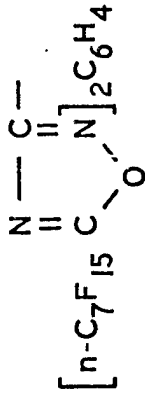

Temp °C	Atm	SM ^a %	Volatiles Formed							
			SiF ₄		CO ₂		CO		R _f CN % ^d	Other mg
			mg	% ^b	mg	% ^c	mg	% ^c		
235	N ₂	98.8	0.07	0.01	1.71	0.15	-	-	0.77	0.3
235	Air	94.7	0.72	0.09	12.19	1.08	0.51	0.07	3.27	2.1
235	N ₂ /H ₂ O ^e	98.3	-	-	5.91	0.52	-	-	-	108
325	N ₂	none	70.80	8.55	94.44	8.43	1.75	0.25	18.93	93.9
325	Air	none	263.0	31.82	170	15.20	7.86	1.11	?	255.6

a In all these degradations a 1-g sample of material was employed; the percent given is that of the starting material.

b Percent of total fluorine present.

c Percent of total carbon present.

d Percent of starting material.

e The water employed was 100.6 mg (5.584 mmol); the 108 mg recovered in volatiles was mainly water plus some fluorinated hydrocarbons.

TABLE V
DEGRADATION OF

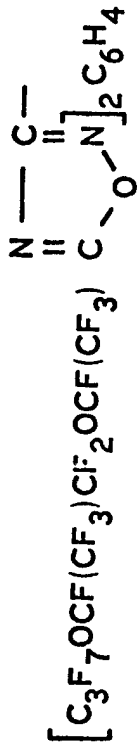

Temp °C	Atm	SM ^a %	Volatiles Formed							
			SiF ₄		CO ₂		CO		R _f CN % d	Other mg
			mg	% b	mg	% c	mg	% c		
235	N ₂	100	T	T	0.76	0.16	-	-	0.1	0.5
235	Air	99.5	T	T	0.83	0.19	-	-	0.10	0.4
235	N ₂ /H ₂ O ^e	99.1	-	-	2.48	0.53	0.07	0.02	-	35.8
325	N ₂	none	65.95	19.59	61.95	14.22	5.42	1.95	16.24	169.3
325	Air	none	58.86	16.11	65.14	13.78	4.39	1.46	19.68	193.3

a In all of these degradations a 450 mg sample of material was employed; the percent given is that of the starting material recovered.

b Percent of total fluorine present.

c Percent of total carbon present.

d Percent of starting material.

e The water employed was 33.3 mg (1.848 mmol); the 35.8 mg recovered in volatiles was mainly water plus some fluorinated hydrocarbons.

in the presence of added water was not really different from that under purely thermal and thermal oxidative conditions one is tempted to speculate that the extent of decomposition is determined solely by thermal dissociation of the oxadiazole. In the case of the 1,4-[bis-(5-n-perfluoroheptyl)-1,2,4-oxadiazolyl]-benzene the presence of oxygen appears to accelerate this process as can be seen by comparing the results found for these conditions at 235°C (see Table IV).

To summarize, based on the limited investigation performed to date the bis-perfluoroalkyl substituted 1,2,4-oxadiazole appears to exhibit the best thermal, thermal oxidative, and hydrolytic stability of the systems studied. The low thermal and oxidative stability of the 1,2,4-oxadiazoles derived from terephthalonitrile oxide seems to stem from the ready dissociation of these materials rather than the oxidative attack upon the CH moieties on the benzene ring. The thermal stability of the two triazines appears to be equivalent under the conditions employed; however the perfluoroalkyl triazine appears definitely oxidatively less stable than the perfluoroalkylether analogue, whereas its hydrolytic stability is the worst of all the materials investigated. The hydrolytic instability of the perfluoroalkyl triazine as compared to the 1,2,4-oxadiazoles is hard to explain and it must be associated both with the triazine ring itself as well as the $-\text{CF}_2-\overset{|}{\text{C}}=\text{N}$ linkage. The hydrolytic stability of the perfluoroalkylether substituted triazine is most likely derived from the presence of the tertiary fluorine on the carbon attached to the triazine ring. It is believed that this behavior is completely independent of the ether linkage and that a perfluoroalkyl substituent attached via a $-\text{CF}(\text{CF}_3)$ group to the triazine ring will exhibit the same hydrolytic stability as the studied perfluoroalkylether system.

THERMAL AND SOLVENT STABLE POLYMERS: SYNTHESIS OF TERFUNCTIONAL
MONOMERS AS POTENTIAL CROSSLINKING AGENTS

By William D. Kray

The original research proposal outlined the possible synthesis of terfunctional monomers by the direct alkylation of acetanilide or 1-alkoxy-2phenyl ethane derivatives with para substituted α,α,α trichloro toluenes. The resulting polyfunctional triphenylmethane derivatives could then be converted to a variety of polyfunctional monomers.

Attempted alkylation of acetanilide with α,α,α trichlorotoluene and aluminum trichloride (Fig. 1) gave a high melting solid with properties inconsistent with the anticipated product ^{1,2}. With the apparent failure of the above procedure other routes to the desired products had to be developed.

The literature is replete with numerous examples of triphenyl carbinol derivatives, with the exceptions of polyvinyl, polyethynyl and polycyanotriphenyl methanes. The first line of endeavor was the reaction of methyl para-fluorobenzoate with the Grignard reaction from parabromotoluene (Fig. 2). This gave p-fluorophenyl-Bis (p-Toluy)l methanol in good yields. The resulting carbinol was converted to the chloride and brominated with NBS in CCl_4 . The yields in all steps were excellent. However the attempted Moffett oxidation gave only a tarry residue and this possible route needs further investigation.

Another procedure investigated was the reaction of methyl or propyl-p-fluorobenzoate with the Grignard reagent from the tetrahydropyranyl ether of p-bromobenzyl alcohol. The resulting Bis-(para-hydroxymethyl phenyl)-para-fluorophenyl carbinol was formed in good yield, This latter compound is available for conversion to other derivatives such as the bis formyl, bis carboxyl and the bis cyano derivatives.

The preparation of the bis-vinyl and the bis ethyl derivatives posed a slightly different problem. The first attempt involved the reaction of methyl-p-fluorobenzoate with the Grignard reagent from 1-(p-Bromophenyl)1-methoxy ethane. The product Bis[4-(2Methoxy-ethyl)-phenyl]-4-fluoro phenyl) methanol was obtained in good yield. Attempts to cleave the methoxy groups with HBr.HOAc were unfruitful. The cleavage of the ethers with dibromotriphenyl phosphorane presented problems because the resulting triphenyl phosphine oxide was similar to the desired product. Fortunately this procedure was easily overcome by a shorter more direct route to the desired vinyl derivatives. The reduction of p-bromoacetophenone followed by dehydration of the alcohol gave p-bromostyrene in good yield. The resulting Grignard reagent from p-bromostyrene reacted smoothly with p-fluorobenzoate esters to give the desired Bis(4-vinyl phenyl)-(4 fluoro-phenyl)-carbinol. The preparation of ethynyl phenyl carbinols is being studied at the present time.

The preparation of triphenyl carbinol derivatives presented one minor problem (Fig. 3) which was the conversion of the carbinol to a more oxidatively stable ether. Initial studies with base-induced displacements on 2,2,2 trifluoroethyl tosylate were fruitless. This was not unexpected because of the poor nucleophilicity of tertiary carbinol anions. However, triphenyl methanol can be converted to the tosylate and the tosylate converted to the 2,2,2-trifluoroethyl ethers with 2,2,2 trifluoroethanol and an equivalent amount of triethyl amine. This non-acidic method will be used to convert the vinylphenyl and the ethynylphenyl carbinols to the desired fluorinated ethers.

Synthesis of 1,1,1-triphenyl-2,2,2,-trifluoroethane derivatives

One area that shows good promise is the direct alkylation of aniline with arylfluoroketones (Fig. 4). When trifluoroacetophenone is heated at reflux with aniline hydrochloride, excellent yields of 1,1-Bis(4-aminophenyl)-1-phenyl-2,2,2-trifluoroethane are obtained. Unfortunately when p-fluorobenzaldehyde is used (Fig. 5), the para-fluoro group is displaced, rendering this route unfeasible for aryl fluorinated ketones. However there are several possible routes to overcome this problem area.

1. Dobner, Ann. d. Chem. 217, 242. [1883]
2. Bayer Villiger. Ber. 37,2857 (1904)

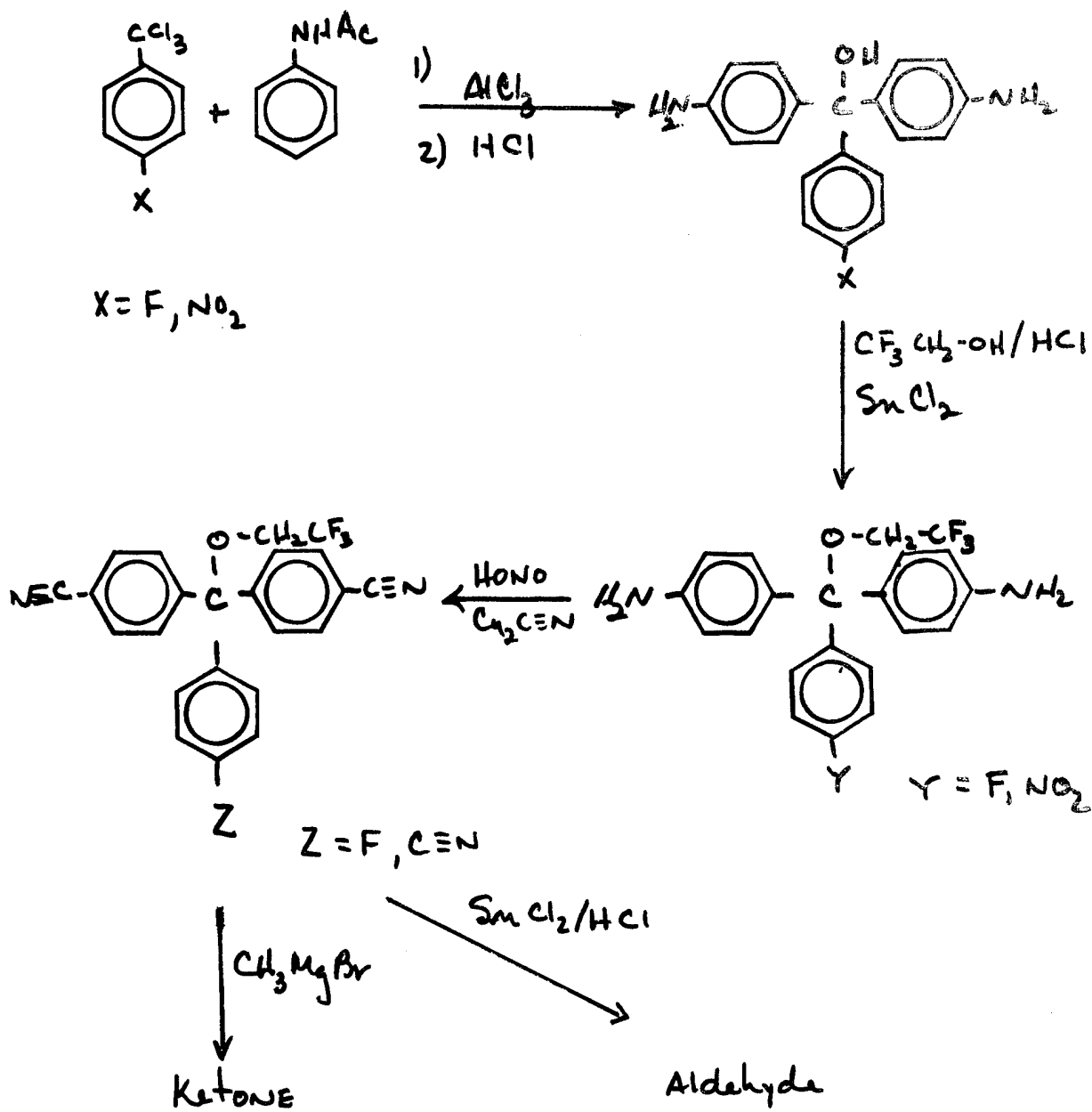

Fig. 1

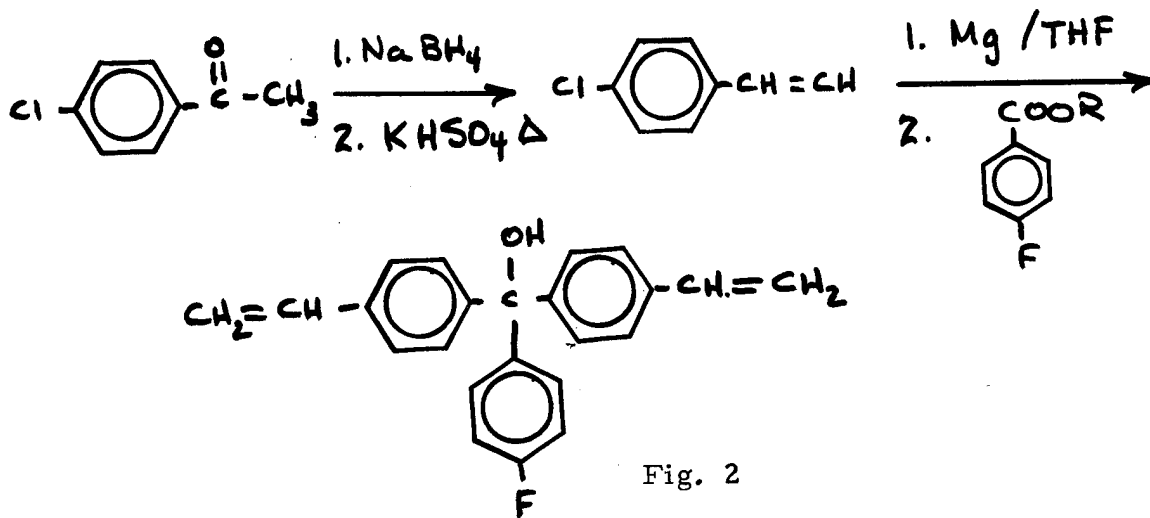
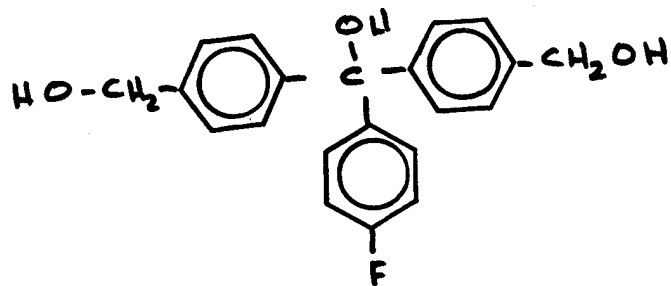
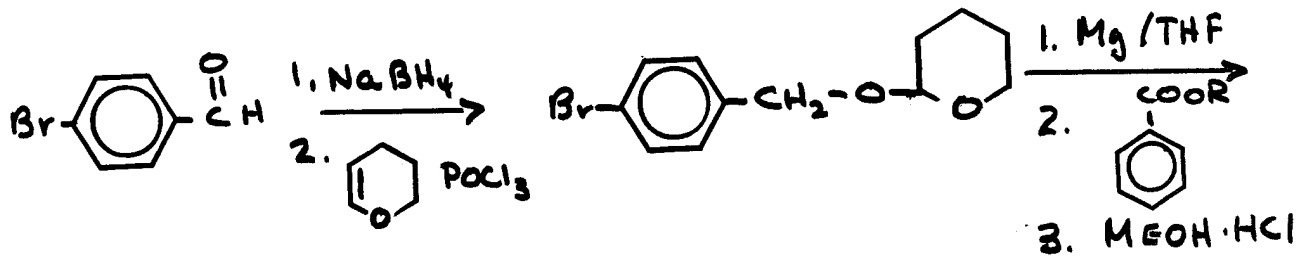
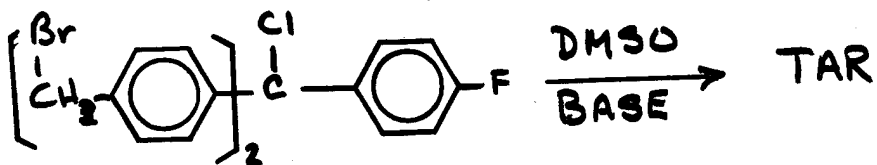
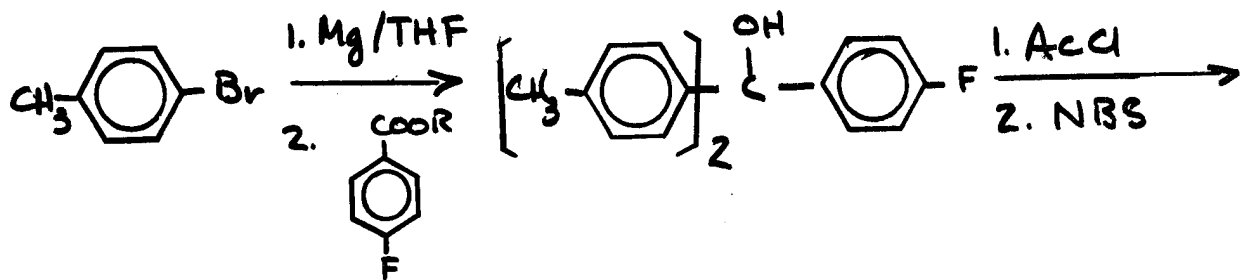

Fig. 2

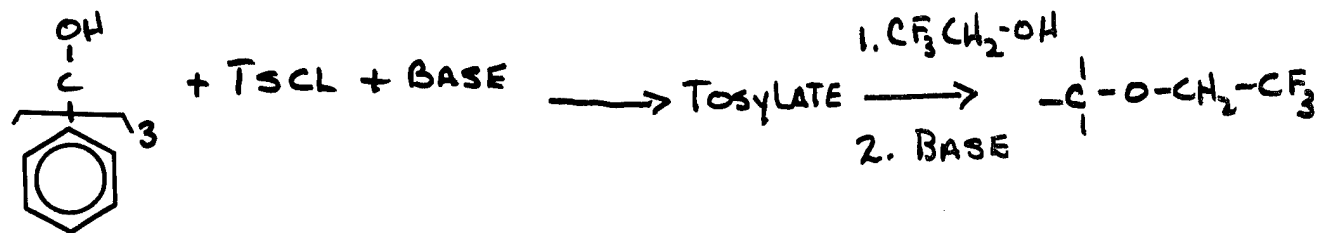
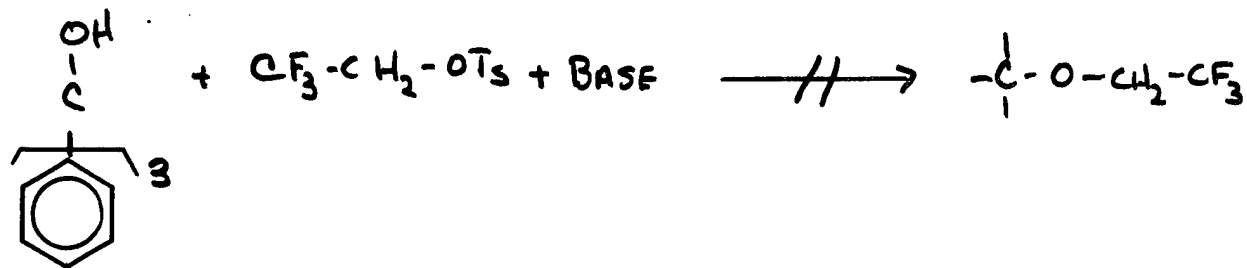
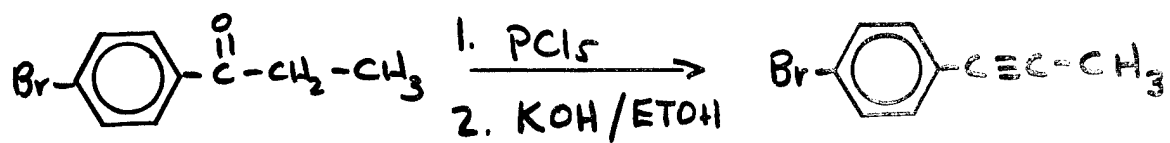

Fig. 3

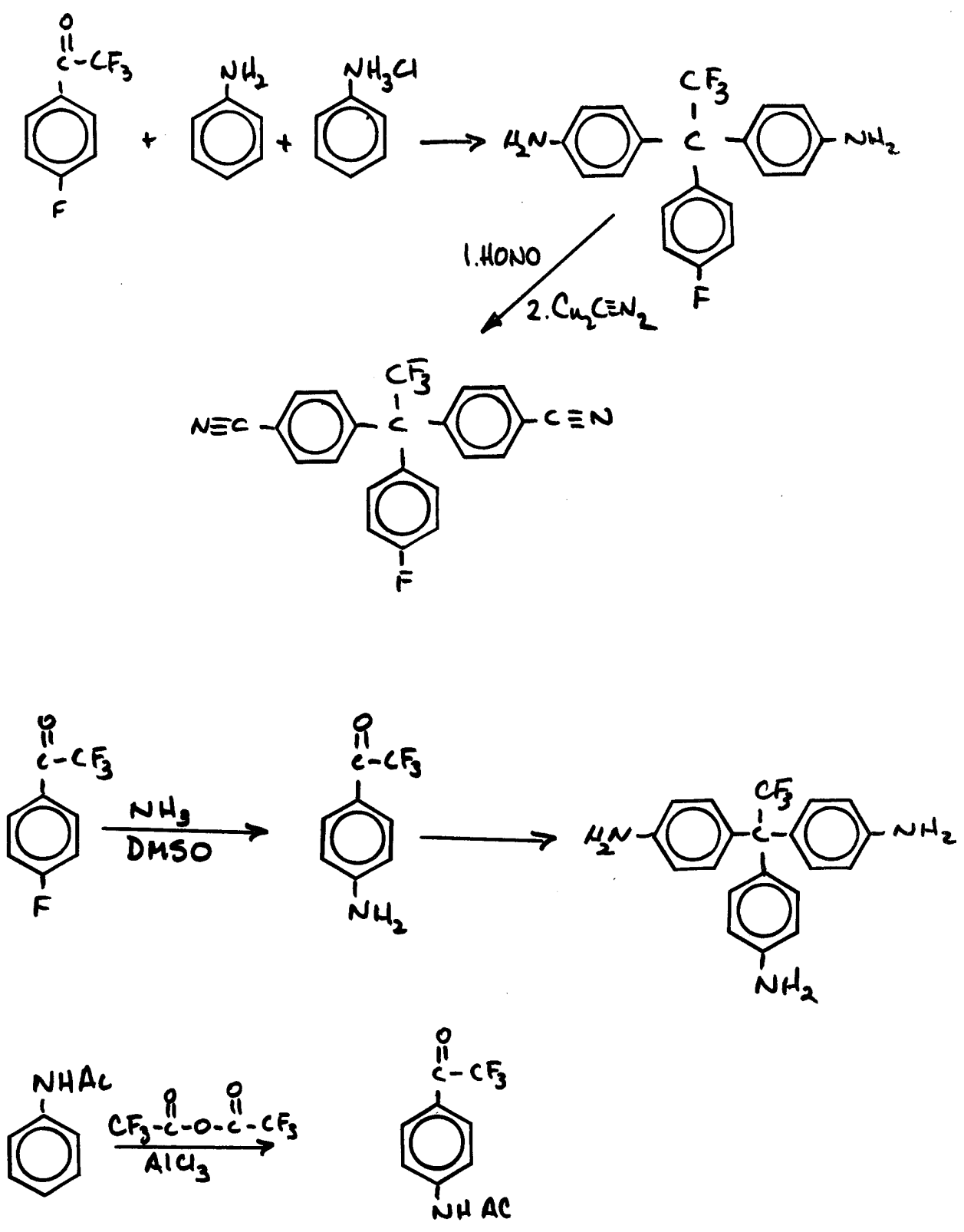

Fig. 4

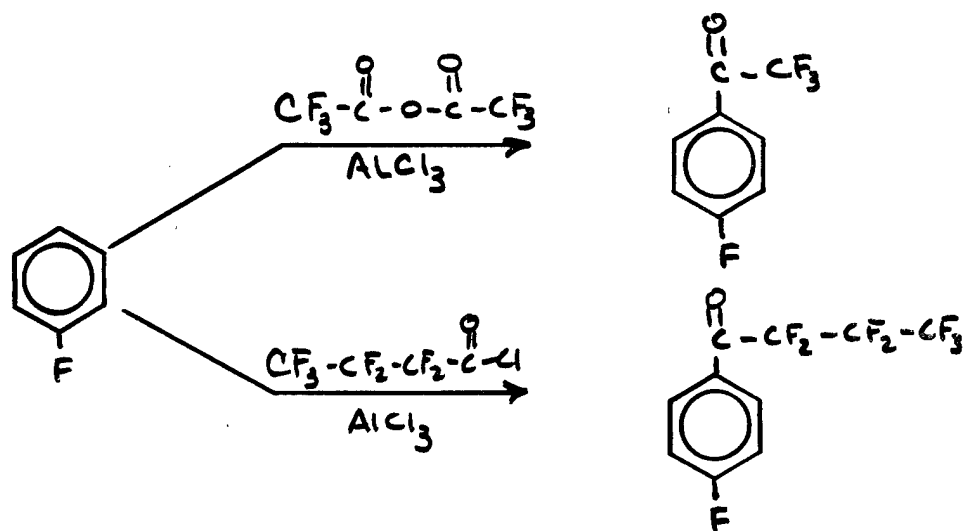
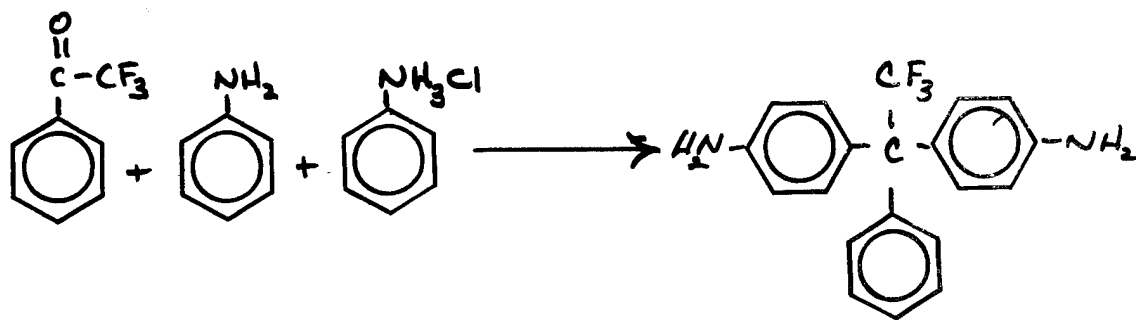
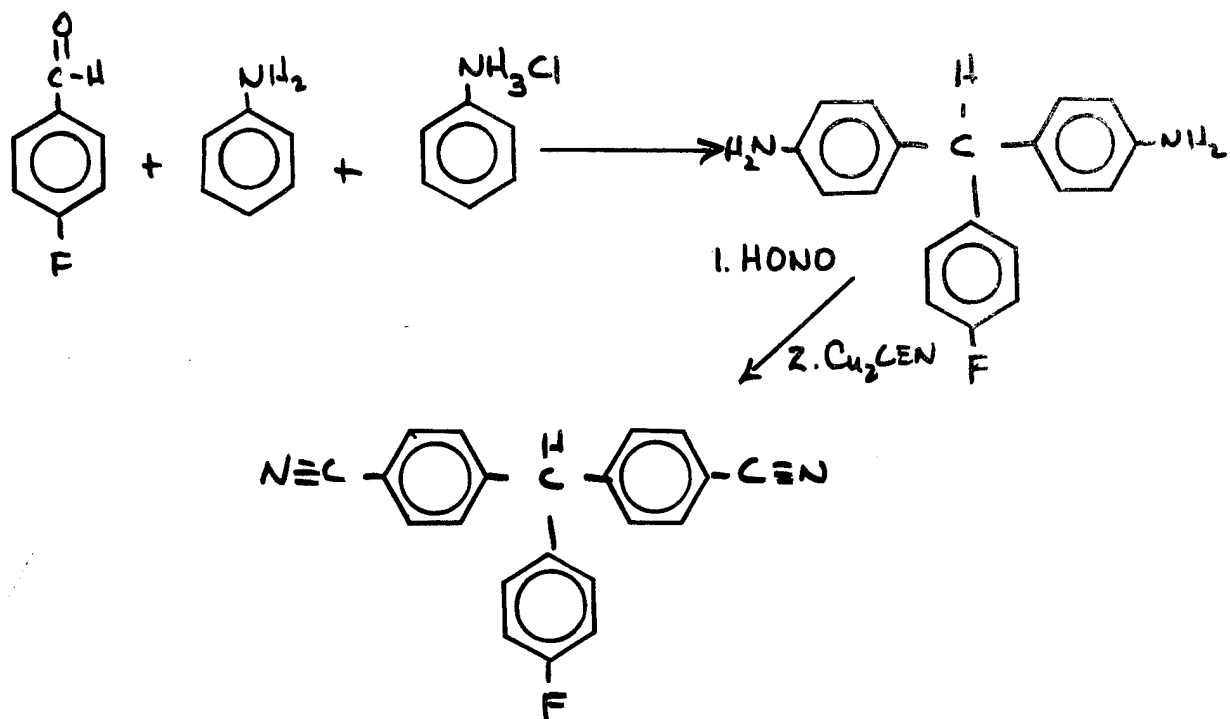

Fig. 5