

PRICES SUBJECT TO CHANGE

D420153

N75-13975-84

THE WIDE WORLD OF PLASTIC TOOLING 8TH  
WESTERN PLASTICS FOR TOOLING CONFERENCE

6 April 1974

DISTRIBUTION STATEMENT A

Approved for public release;  
Distribution Unlimited

DISTRIBUTED BY:

**NTIS**

National Technical Information Service  
U. S. DEPARTMENT OF COMMERCE

19960227 052

-22663

PLASTEC

22654

DTIC QUALITY INSPECTED

# DISCLAIMER NOTICE

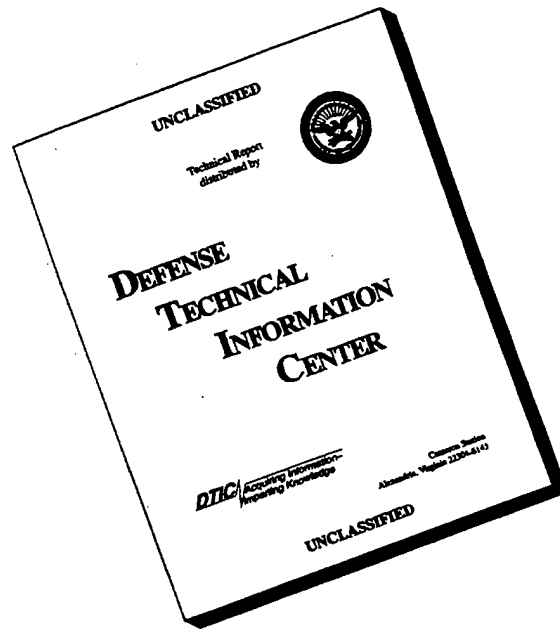

**THIS DOCUMENT IS BEST QUALITY AVAILABLE. THE COPY FURNISHED TO DTIC CONTAINED A SIGNIFICANT NUMBER OF PAGES WHICH DO NOT REPRODUCE LEGIBLY.**

# THE WIDE WORLD OF PLASTIC TOOLING

## 8th ANNUAL WESTERN PLASTICS FOR TOOLING CONFERENCE

APRIL 3 - 6, 1974 MASTER HOSTS INN, SAN DIEGO, CALIFORNIA

THE WIDE WORLD OF PLASTIC TOOLING  
(Society of the Plastics Industry, Inc.)  
66 p HC \$4.25

N75-13975  
THRU  
N75-13984  
Unclas

H2/27 05604

Reproduced by  
NATIONAL TECHNICAL  
INFORMATION SERVICE  
US Department of Commerce  
Springfield, VA. 22151

PRICES SUBJECT TO CHANGE



Co-Sponsored By



PLASTICS FOR TOOLING GROUP

Western Section

The Society of the Plastics Industry, Inc.

and

SAN DIEGO STATE UNIVERSITY

Department of Industrial Arts

N O T I C E

THIS DOCUMENT HAS BEEN REPRODUCED FROM THE BEST COPY FURNISHED US BY THE SPONSORING AGENCY. ALTHOUGH IT IS RECOGNIZED THAT CERTAIN PORTIONS ARE ILLEGIBLE, IT IS BEING RELEASED IN THE INTEREST OF MAKING AVAILABLE AS MUCH INFORMATION AS POSSIBLE.

WESTERN PERIODICALS COMPANY  
13000 Raymer Street  
North Hollywood, California 91605

Is pleased to announce the availability of the following publications:

SOCIETY OF THE PLASTICS INDUSTRY  
Western Section

- |     |  |                      |
|-----|--|----------------------|
| 8th | ANNUAL WESTERN PLASTICS FOR TOOLING CONFERENCE.<br>The Wide World of Plastic Tooling.<br>San Diego State University. April 3-6, 1974 | \$10.00<br>Hard Copy |
| 7th | ANNUAL WESTERN PLASTICS FOR TOOLING CONFERENCE.<br>California State University at San Diego.<br>April 13-14, 1973                    | \$ 7.50<br>Hard Copy |
| 6th | ANNUAL WESTERN PLASTICS FOR TOOLING CONFERENCE.<br>The Wide World of Plastic Tooling.<br>San Diego State College. March 24-25, 1972  | \$15.00<br>Hard Copy |
| 5th | ANNUAL WESTERN PLASTICS FOR TOOLING CONFERENCE.<br>San Diego State College. April 2-3, 1971  | \$15.00<br>Hard Copy |

Also:

- |  |   |                            |
|--|---|----------------------------|
| 28th Conference<br>May 5-7, 1971         | Technical, Sales/Marketing, Management,<br>Papers | \$15.00<br>Hard copy       |
| 27th Conference<br>May 27-29, 1970       | Management & Markets Bridge to the<br>Future      | \$15.00<br>Hard copy       |
| 26th Conference<br>April 23-25, 1969     | Technical and Management Papers                   | \$10.00<br>Microfiche only |
| 25th Conference<br>May 1-3, 1968         | Technical and Management Papers                   | \$10.00<br>Microfiche only |
| 24th Conference<br>April 26-28, 1967     | Technical and Management Papers                   | \$10.00<br>Microfiche only |
| 23rd Conference<br>March 30-Apr. 1, 1966 | Technical and Management Papers                   | \$10.00<br>Microfiche only |
| 22nd Conference<br>March 25, 26, 1965    | Technical and Management Papers                   | \$10.00<br>Microfiche only |

All shipments are F.O.B. North Hollywood, California.  
California residents add 6% sales tax.  
EXPORT PRICES please add 20% to cost of material.

TABLE OF CONTENTS

<u>Name</u>	<u>Title</u>	<u>Page</u>
MacDonnell, Robert J.	Resin Application Equipment.....	1 ✓
Ryan, William M.	Urethanes, Elastomers for Tooling.....	5 ✓
Schuetz, Robert C.	Ft. Carson Involvement in Plastics at the Training Aid Center.....	9 ✓
Poasy, Wm.	H. T. Epoxy Tooling Resins with Improved Handling and Safety Characteristics.....	14 ✓
Winter, L. E.	Basics of Plastic Tooling.....	18 ✓
Clow, William E.	Quality Control & Product Design in a High- Volume FRP Manufacturing Plant.....	21 ✓
Bushman, Edwin F. and Bushman, Bruce E.	Resins Scarce? Make Tools and Parts with Solid Waste and Conglomerate-Composites.....	23 ✓
Gomez, Arthur R.	Advanced Tooling Techniques using a Thermo- plastic Compound.....	37 ✓
Ball, Derek; Feldman, T. and Pickett, E.	Applications of Curved Systems.....	45 ✓

# THE WIDE WORLD OF PLASTIC TOOLING

## 8th ANNUAL WESTERN PLASTICS FOR TOOLING CONFERENCE

APRIL 3 - 6, 1974 MASTER HOSTS INN, SAN DIEGO, CALIFORNIA



Co-Sponsored By



PLASTICS FOR TOOLING GROUP

Western Section

The Society of the Plastics Industry, Inc.

and

SAN DIEGO STATE UNIVERSITY

Department of Industrial Arts

## HIGHLY FILLED PLASTICS

RESINS SCARCE? MAKE TOOLS AND PARTS WITH SOLID  
WASTE AND CONGLOMERATE-COMPOSITES.

Edwin F. Bushman

and

Bruce E. Bushman

(Presented at the 8th Annual Western Plastics For  
Tooling Conference, San Diego, Calif. 1974, of the  
Society of the Plastics Industry, Inc.)

19 Lagunita, P. O. Box 581  
Laguna Beach, Calif. 92652  
(714) 494-6393

## RESIN APPLICATION EQUIPMENT

Robert J. MacDonell  
 Venus Products, Inc.  
 Kent, Washington

Abstract

The development of Hydraulic Injection and mixing of catalyst internally, under pressure, with a balanced system of high ratio pumps, has allowed the development of mechanical application equipment. This equipment is capable of economical handling and converting of material in the open mold laminating process. Casting systems, as well as spray systems, can be considered in the mechanized process. Large volume markets are being developed as a result of advanced methods of handling and converting with these more competitive processing techniques.

Material development generally precedes equipment to accommodate its useage and equipment development advances at a more rapid rate than the industry as a whole. The simplicity of the open mold laminating process and its many advantages such as producing complex shapes of various dimensions, relatively low cost tooling, making use of modest skill labor and low investment applicating devices, such as the bucket and brush, initially accommodated the resin and glass to make open mold laminating a product manufacturing success.

Evolution of material handling, caused by the necessity to find the better way, introduced the spray method for applying resin to the glass and mechanization through spray equipment was accepted by the industry. Coupled with the roving cutter (figure 1) glass and resin could then be applied rapidly and effectively to the open mold.

Increased quality of both resin systems and glass, allowed more sophistication to spray-up equipment and today it is available to such a degree of excellence that hand held spray-up units offer positive metering, internal mixing, low pressure spray of non-aspirated resin solids capable of rapidly wetting out quality treated rovings

expressly designed for this particular application. Industries acceptance of this amount of mechanical assist is universal and can be considered the conclusion of resin applicating equipment and of Generation I.

## Generation II.

Elimination of the human error factor and its resultant effect of more consistent and economical use of materials at higher volume rates is the object of Generation II mechanization.

The reciprocator principle, for spray applications in the production of sheet stock, is a prime example of the advantages gained by Generation II mechanization. The dual spray heads, one to apply gel coat and the other to apply the resin and glass composite, are mounted on the traversing carriage (figure 2) and are triggered remotely. The consistant rate of travel of these spray heads and the fact that they are always the same distance from the mold, allows accurate placement of the materials to a degree previously impossible. Gel coat can be applied over the entire mold with no greater than a 1 mil error factor.

Laminate thickness can be accurately controlled by controlling the rate of mold travel with the aid

of a solid state mold drive control. A mechanical roll out system eliminates man power and the time encountered by a hand operation even though the ability to apply a uniform laminate would have resulted in an easy to finish laminate.

The complete reciprocator, with the H.I.S. (Hydraulic Injection System) pumping units, is shown in figure 3. Material metering and mixing units with a high degree of material control, are essential to making Generation II mechanisms practical. Non misting, minimal overspray systems are mandatory to environment control and allow the single operator machine to be used in the same area in which its production is to be utilized. From 10 to 80 square foot of laminate, per minute, can be accomplished with these units, on a continuous basis.

The mechanized impregnator has made a tremendous contribution to open mold laminating of large structural parts, such as barges, barge covers, building panels and boats. The impregnator unit (figure 4) shows the H.I.S. casting system supplying catalyzed resin between the dams on the upper trough formed by the squeeze rolls. The feed rolls are supplying woven roving and glass mat through the nip of the squeeze rolls where the composite is impregnated.

#### BIOGRAPHY

Robert MacDonell has a background in research and development; liaison between engineering, production and plastic technology. He has been with Venus Products, Inc., since 1963, and has been totally involved in equipment for the open mold laminating and spray-up industry. He worked on the development of the Hydraulic Injection System (H.I.S.) which has since allowed mechanized equipment for the P.K.P. Industry to become a reality. For the past several years Bob has devoted most of his time to the mechanization program. He is active in several organizations including the Pacific Northwest Chapter of the S.P.E.

Micrometer adjustment of the compression value of the squeeze rolls controls the resin to glass ratio up to 50% with no more than a plus or minus 2% error. Figure 5 shows the impregnated material being placed on the mold. The unit can place the impregnated material, on the mold, at up to 30 feet, per minute.

The impregnator is available in several mounted forms to accommodate various applications. Figure 6 shows the most versatile of the material handling devices, the bridge crane impregnator. It is a completely mobile material handling applicator. Its travel, controlled by one operator, is mobile in any direction and the turret is rotatable 360°. The same operator has complete control of material delivery rates. An elevator staging can be controlled either by the operator or laminator to assist in the placement of the impregnated materials.

Other Generation II mechanized systems are now in their final test stage and will be available near the end of 1974. The materials are available and of high quality and versatility to allow great use of Generation II equipment. With the present material shortages requiring close accounting of materials by all manufacturers, the advancement to mechanization should be faster than normal and Generation II should evolve to Generation III applicators (automation) most rapidly.

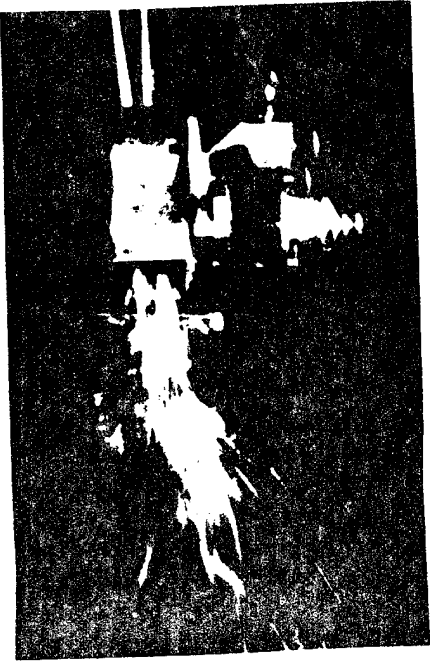

Figure 1

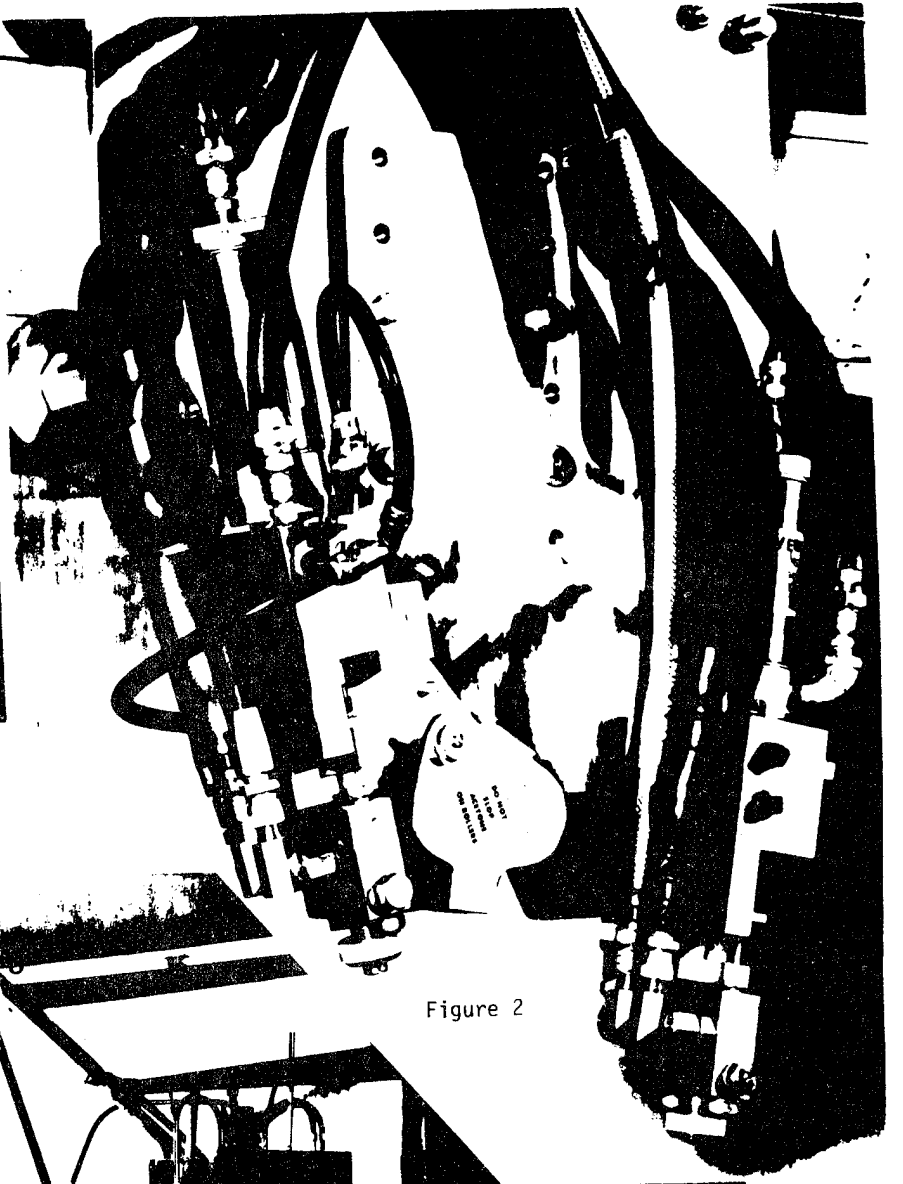

Figure 2

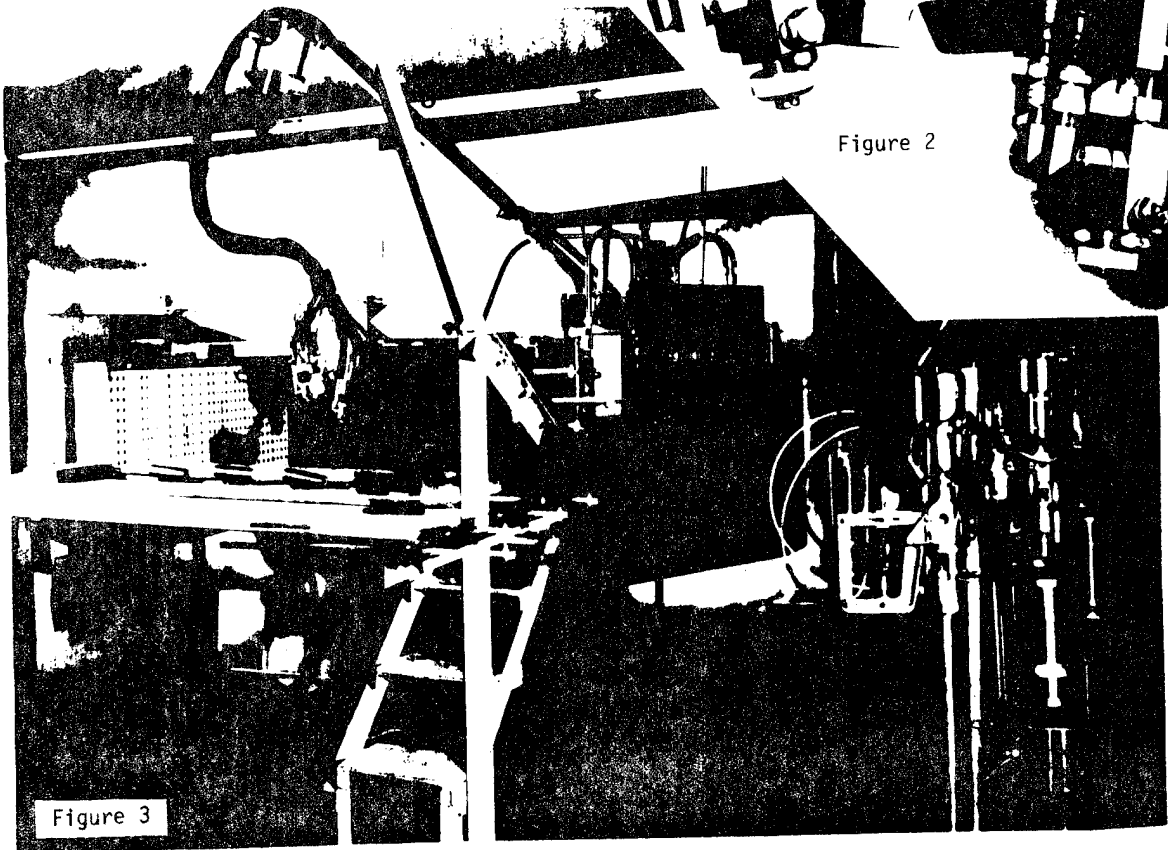

Figure 3

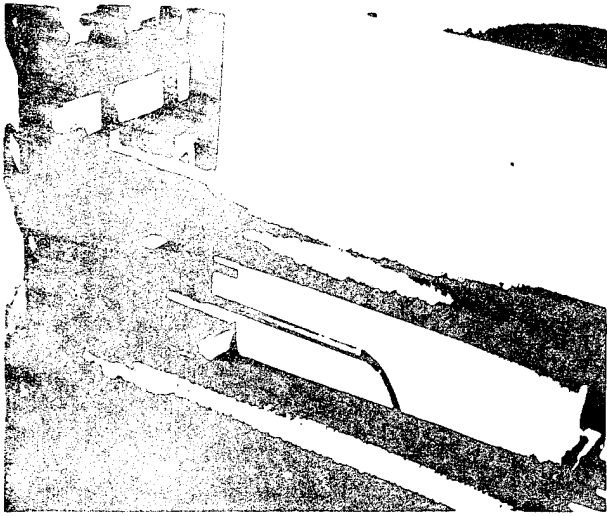

Figure 4

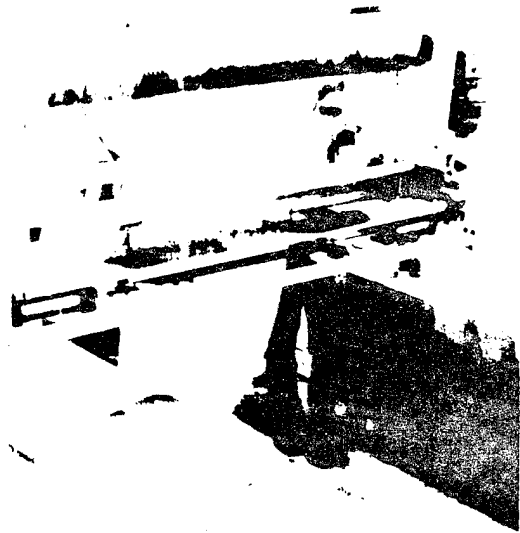

Figure 5

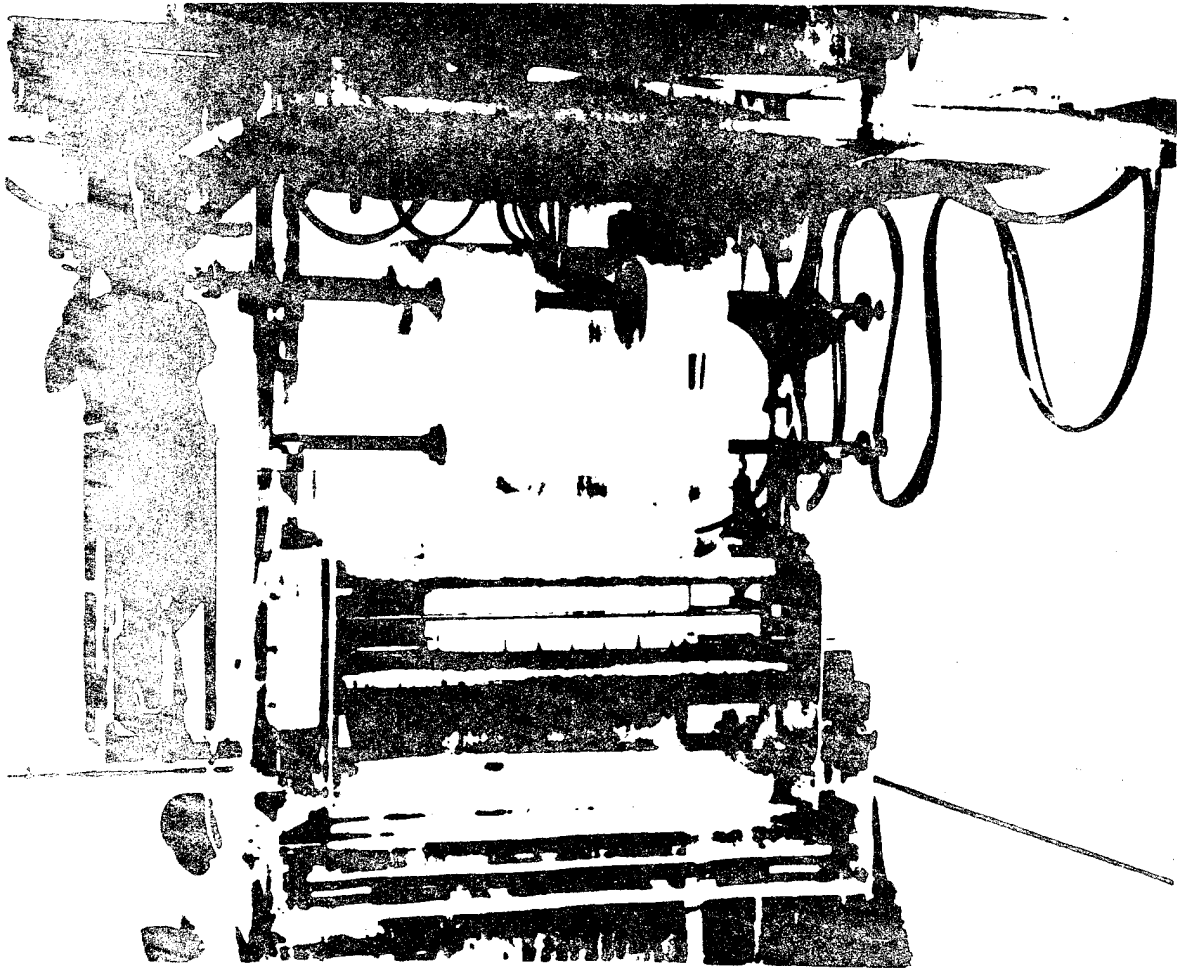

Figure 6

URETHANES, ELASTOMERS  
FOR TOOLING

William M. Ryan  
HYSOL DIVISION, THE DEXTER CORPORATION  
City of Industry, California

Abstract

This paper provides an introduction to urethane vocabulary, describes certain urethane laboratory tests, and discusses some handling hazards common to most urethane tooling elastomers marketed today.

1. INTRODUCTION

You probably chose urethane in the first place because you wanted rubber-like properties in a liquid castable compound and you knew that urethanes were unusually tough and abrasion resistant plastics and so they should be durable.

But, urethanes, like aspirin, are not all alike. Certainly the wrong urethane will not cure your headaches.

Selecting the right urethane from the wide variety presently available can be a difficult problem. Urethane suppliers provide laboratory data on their materials and you have the difficult task of relating their lab tests to your needs.

So, a few moments spent familiarizing yourself with your supplier's urethane vocabulary and his lab tests are well spent.

2. URETHANE CHEMISTRY AND VOCABULARY

Urethanes, chemically, are materials derived from the reaction of an isocyanate (NCO) and a hydroxyl (OH) or amine (NH<sub>2</sub>) group. When the isocyanate (R-NCO) reacts with the hydroxyl (OH) group of an alcohol or glycol (HO-R'), the resulting product is actually a urethane (R-NH-CO-O-R') when an amine (RNH<sub>2</sub>) is used in place of the alcohol, the resulting product is called a urea (R-NH-CO-NH-R'). (1) Urethanes containing the amine derived urea linkages are generally tougher than urethanes containing only glycol derived urethane linkages. Hydroxyl containing materials are termed alcohols, diols, triols, tetrols, or polyols, depending upon the number of hydroxyl groups each contains. An alcohol contains only one hydroxyl group, but is rarely used, as a mono hydroxyl group acts as a

chain stopper. The general term polyol is used to refer to compounds containing two or more hydroxyl groups. Diols (2 groups) are used as chain extenders while triols (3 groups), and tetrols (4 groups) are used as cross linkers to increase hardness.

Your supplier may refer to the part containing the isocyanate (NCO) as the prepolymer and caution you to protect it from moisture in the air. The isocyanate group can not easily tell the difference between the OH in water and the OH in the curing agent. However, when it reacts with the OH in water a bubble of carbon dioxide is formed.

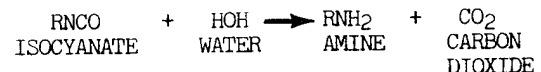

For this reason, contact with water may cause skinning and gelation in storage or bubbling during cure.

3. URETHANE LABORATORY TESTS

3.1 HANDLING RELATED TESTS

Your supplier usually describes handling in terms of:

- (1) Mix ratio
- (2) Viscosity of each component
- (3) Mixed viscosity
- (4) Pot life
- (5) Cure time and cure temperature

Mix ratio is given by weight or volume and, as urethanes are ratio sensitive, a tolerance of 5 to 10% should be maintained for best results.

Viscosity is given in CPS (centipoise) and is conveniently measured with a Brookfield Viscometer. A spindle rotating at a set speed through the fluid causes the meter to deflect and this deflection is converted directly to CPS. The number of the spindle and speed in RPM (revolutions per minute) are recorded. Recording the speed is important because all fluids do not give the same viscosity at every speed. A fluid whose viscosity does not change with speed is referred to as a Newtonian fluid. A fluid whose viscosity drops with increasing speed is called thixotropic and a fluid whose viscosity increases with increasing speed is called dilatant.

Viscosity decreases with increasing temperature and increases when temperature drops. Generally, viscosities are reported at 25°C.

Pot life, given in minutes or hours, is a measure of the usable life of the compound once mixed. Like viscosity, pot life is temperature dependent. Low temperature extends pot life; high temperature shortens it.

Pot life is determined in the laboratory by measuring viscosity versus time. (Figure 1)

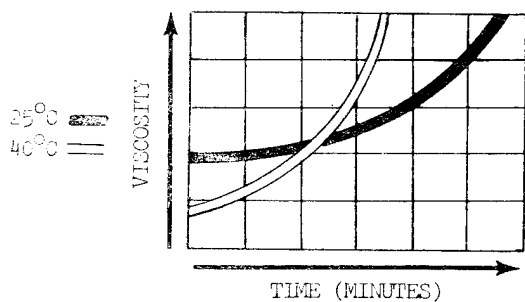

Figure 1  
Pot Life

Another method of measuring pot life requires use of a gell meter such as the Sunshine gell meter. Ten grams of the mixed urethane is placed in a test tube. The tube is placed in a constant temperature bath and a glass probe inserted in the tube. The probe rotates in the tube until the viscosity exceeds 100,000 CPS at which time a buzzer sounds and the number of minutes to gell is read directly from the meter.

Cure time is the time required to reach maximum mechanical properties. It also is extended by lower temperatures and shortened by higher temperatures. Often parts appear completely cured, but if subjected to sufficient stress, may fail when the suggested cure time is not allowed.

Cure time is determined in the laboratory by measuring a mechanical property such as hardness with respect to time. (Figure 2)

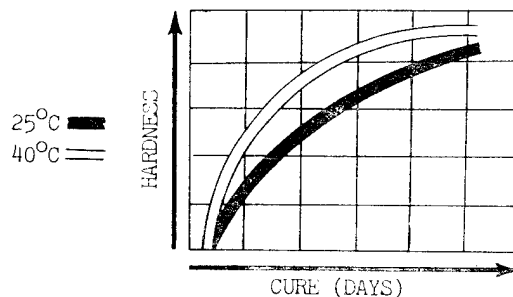

Figure 2  
Cure Time

### 3.2 PERFORMANCE RELATED TESTS

Urethane castable elastomers are available with an enormous range of mechanical properties. The following are most often considered:

- (1) Hardness
- (2) Tensile
- (3) Elongation
- (4) Tear Strength
- (5) Compression Set
- (6) Thermal Stability

Hardness is generally measured with a Shore Durometer. (2) The Durometer consists of a simple meter which is pressed against a flat surface, this depresses a indenter and causes the gauge to deflect. The Durometer is available in several ranges. Shore A and Shore D being the two commonly used for plastics. Both scales read from 0 to 100. The Shore A scale is used on soft elastomers while the Shore D scale is used for hard elastomers. The A and D scales overlap but no convenient conversion is available. 95 Shore A converts to about 50 Shore D. 80 Shore A is about 30 Shore D. Above 95 Shore A, the D scale should be used and below 25 Shore D, the A scale is more accurate.

Liquid cast urethanes are available from 15 Shore A to 95 Shore D.

Tensile and elongation are determined by cutting a specimen per ASTM (The American Society for Testing Materials) D412 as in Figure 3.

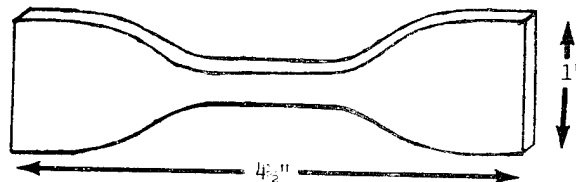

Figure 3  
Standard Dumbbell per ASTM D412

The cross sectional area of the Dumbbell is measured with a micrometer and two marks are made one inch apart in the narrow section. The sample is placed in a machine and stress applied by moving one end at 20 inches per minute. Ultimate elongation is taken by measuring the distance between the marks at break, subtracting the original inch and reporting the result in percent. Ultimate tensile strength is taken by recording the pounds necessary to break the specimen and dividing by the cross sectional area. The result is expressed in pounds per square inch (PSI).

Urethane elastomers are available which exceed 1,000% elongation and others are available with tensile strengths exceeding 10,000 PSI.

ASTM D624 describes two of the four popular tear strength tests. The various tests differ in the shape of the specimen used, but all involve pulling a specimen and recording the pounds required to rip or tear it apart.

The ASTM D624 Die C (Graves Tear) is shown in Figure 4.

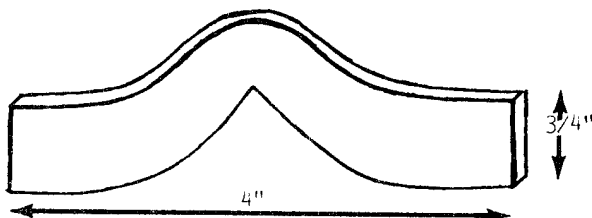

Figure 4  
ASTM D624 Die C Tear

In the Graves tear strength test the thickness of the specimen is measured and the pounds required to tear divided by this thickness in inches and the result recorded as pounds per linear inch (PLI).

Urethanes are available with Graves Tear as high as 1,000 PLI.

Compression Set as in ASTM D395 is defined simply as "the residual decrease in thickness of a test specimen measured 30 minutes after removal from a suitable loading device in which the specimen had been subjected for a definite time to compressive deformation under specified conditions of load application and temperature". (3) In Method B (compression under constant load) a one half inch thick by one inch diameter button is squeezed to stops and held at the test temperature for the given time, released, allowed to rebound as best it might, and the set, expressed as a percentage of the original, recorded.

Urethanes subjected to compression at 70°C for 24 hours exhibit sets around 30 to 50%.

Thermal stability has been measured in the lab by exposing a sample to elevated temperature for pro-

longed periods of time and recording changes in mechanical properties. More recently Differential Scanning Calorimetry (DSC) and Thermogravimetric Analysis (TGA) are being used to provide more accurate information on the exact temperatures at which thermal decomposition reactions occur. (4) In TGA, a graph of weight loss versus temperature or weight loss versus time, at any given temperature, is obtained. (5) In DSC, a graph of quantitative thermal energy flow is obtained. The DSC graphs pinpoint the onset temperatures of oxidative decomposition (weight gain) or volatile decomposition (weight loss) and can detect rearrangements, melts, and crystallizations not observable via TGA.

Some urethanes are available which will operate up to 150°C.

#### 4. URETHANE SAFETY

Having chosen a urethane with the properties that you can handle, you should also give thought to safety before you begin. A system containing Toluene diisocyanate (Figure 5) will require masks and ventilation to protect people from the "asthma" like symptoms of exposure.

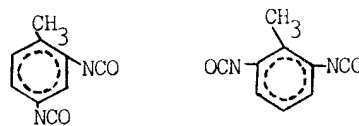

Figure 5  
2,4 & 2,6 Toluene diisocyanate (TDI)

Or you could use a 0% free TDI (Figure 6) or polymeric isocyanate based system (Figure 7). As these systems have lower vapor pressure less exotic ventilation is required.

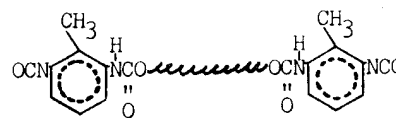

Figure 6  
0% Free TDI Prepolymer

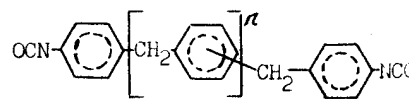

Figure 7  
Polymeric Isocyanate

Recent OSHA rulings have required use of special equipment to handle urethanes containing methylene bis 0-chloro aniline (MOCA). MOCA (Figure 8) gives excellent mechanical properties but most prefer to use alternate urethanes rather than redesign their handling areas.

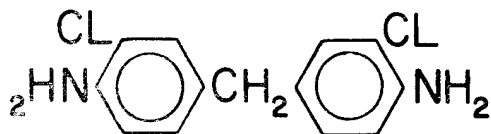

Figure 8  
MOCA

#### 5. CONCLUSION

Armed with common vocabulary, understanding of your supplier's lab tests, with a keen eye on safety practice, you are now well on your way to making parts until the material either becomes in short supply, unavailable, or obsolete and you have to start over.

#### 6. REFERENCES

- (1) Sealants, Adolfas Damusis  
Reinhold Publishing Corporation, 1967  
Chapter 5, pages 116-174
- (2) Bulletin R-12 Shore Durometer  
Shore Instrument & Manufacturing Co.  
Jamaica, New York
- (3) Book of ASTM Standards  
American Society for Testing Materials  
1958  
Part 9, page 1263
- (4) Thermal Analysis an Overview  
Paul F. Levy  
American Laboratory, January 1970
- (5) Advances in Urethane Science and  
Technology  
K. C. Frisch and S. L. Reegen  
Technomic Publishing, 1971  
Volume 1, Chapter 3, pages 49-63

#### 7. BIOGRAPHY

Bill Ryan is a Project Leader with the HYSOL DIVISION of THE DEXTER CORPORATION and is active in urethanes and epoxies as they relate to electrical insulation and tooling. Bill is a member of the American Chemical Society and a member of the Public Affairs Subcommittee of the Southern California Section of the American Chemical Society.

**FT. CARSON INVOLVEMENT IN PLASTICS  
AT THE TRAINING AID CENTER**

Robert C. Schuetz  
Ft. Carson, Colorado

**1. INTRODUCTION**

There is approximately (40) personnel involved in the Training Aid Center at Ft. Carson. Our primary purpose is to support the training of the soldier by any means possible. The Training Aid Center consists of an Audio-Visual section, which supplies film strips and tapes for classroom instruction, a Graphics section, which handles the printed material, a photography shop, and a Devices Center. The Devices Center is the one I work out of. We have (10) people at this time, which consists of four Plastic Model Makers, a Plastic Engineer Technician, which is my title, two wood model makers, a machinist, painter and draftsman. To assure that we keep abreast with new developments in the Plastics Field, the Model Makers and Myself attend a (5) week course at a major University every year. This consists of some Suppliers and Formulators in plastics bringing in their products for us to test and work with. We also go into Chemistry and new methods of Tooling.

I would like to give you just a little background of the responsibility Training Aids Centers have had in the Military up to now. Some twenty years ago the Training Aids Centers mainly consisted of Charts used for diagraming and describing equipment which would be used by the G. I. In the late 1950's it was expanded into Woodworking and some sheet metal materials to make working models of military equipment to be used in classroom demonstrations for training purposes. Wood Models were a good starting point but each model had to be cut out. This was very time consuming and the models were limited as to just how detailed they could be made.

In the early 1960's the Training Aid Center started to work with sheet plastics material, primarily plexiglass, which enabled them to

Fabricate working models of military equipment and dye or color code them to show the moving parts of each model. At this time the people involved were unskilled and not knowledgeable of Plastics and what methods were needed in order to work with it properly.

Today the Training Aid Centers are involved in many different types of plastics. Each major post in the United States is in some form or degree in Plastics. We at Ft. Carson are deeply involved and continuously experimenting to find new methods and materials to fill the expanding needs of the military. Due to the more sophisticated equipment used by the soldier now we must provide training aids that are capable of keeping personnel that are in the instructors classes alert and also keep the instructors from becoming complacent in their teaching duties.

In order to give you a more specific idea of what we are accomplishing in Plastics, I have put together a number of Slides that will depict the operation and capability of our Training Aid Center. These slides are pictures of what we have actually fabricated in our plastics shop. We will attempt to cover Thermo-plastics, Thermo-set plastics, Epoxy Tooling, RTV Rubber Molds, Vacuum Forming of Thermo plastics, and Rigid Urethane Foams. We are at this time setting the stage to get the equipment and become involved in Injection Molding.

**2. VACUUM FORMING**

The first group of slides I have with me will cover vacuum forming of sheet material. Before we are ready to set up our vacuum forming machine for a production run, we

fabricate a model from pattern pine or hydra-stone. When making up this wood model we take into consideration the depth of the draw and what sheet material would be best suited for the finished product. The materials we are most familiar with are Hi-Impact Styrene, ABS, Kydex, Uvex and PVC. Because of the cost and the time cycle, of heating and cooling Hi-Impact Styrene we fabricate numerous items from it. When making up this wood model we also take into consideration the depth of the draw, how thick the material should be and if the material can be removed easier from a female or male pattern. One other big factor is, that in order to keep the cost low, can the tooling be designed in such a way that the excess material is easily removed with a band saw or other inexpensive piece of equipment.

Our vacuum forming machine will hold a 3' X 4' sheet of plastic material. One of the items we fabricate with this machine, is our instrument Flying Hood. The Instrument Flying Hood is used, by the helicopter pilots, to block his view out of the aircraft. He must look straight ahead at his instrument panel. We have set up the tooling to fabricate five hoods per cycle. The important contact points of the hood are on the inside, therefore, our tooling is a male type. There is enough draft on the sides to allow the part to be easily removed. This particular part is fabricated from Hi-Impact Styrene and is .125 thousandths thick. We also have an instrument flying hood that is in the development stages, for the Air Force, which is quite different and used for instrument flying in fixed wing aircraft. The material for this hood is Hi-Impact Styrene and is .157 thousandths in thickness.

In some cases, it is necessary to use an assist to keep the material from veining and properly forming around the tooling. Our vacuum form machine has the overhead assist which can be used as a plug or we can set it up for prestretching the sheet plastic. When making aggressor helmets which are used by the military in field problems we do use the overhead assist. These helmets fit over the military helmet liner and are also fabricated from Hi-Impact Styrene.

Another one of the items we fabricate, using the vacuum form process, is a helicopter. Most of the parts are vacuum formed of Uvex material. We use 1/4" Uvex and because of the deep draw this will give us the necessary rigidity for the body and tail. The parts must

be cemented or glued together and Uvex is easily dissolved and softened with methylene chloride and will adhere well. The blades and some of the other parts are machined from Lexan. Because of the length of the blades the Lexan was chosen as it is stronger. The scaled down model of the helicopters was an important training aid because it is used in the classrooms by instructors to show hospital personnel in large cities how to load and unload the stretchers from the helicopters safely.

### 3. RTV RUBBER MOLDS

Another phase of our involvement in plastics is the RTV rubber molds. We call these molds skin molds because the RTV rubber is between 1/4" and 1/2" thick over the item we wish to reproduce. We back the RTV rubber with a rigid backing of urethane elastimer. This supports the RTV rubber and holds it in shape. It is usually a two piece mold and we clamp the two halves together so this is another reason for the rigid backing. The finished product will be no better than the master or plug that the mold was made off of, so it is important to repair any imperfections in the master.

Some of the thermoset materials that we use in reproducing items from RTV molds are urethane elastimers, polyurethanes, polyesters and urethane foams. The RTV mold that I showed you was for an M16 rifle. The material used to pour this rifle is urethane elastimer. The rifles are used for training and weigh approximately the same weight as the original rifle. We reinforce the rifle with a metal rod down the middle and to this rod we weld studs to fasten the rifle slings to. The rifles cost the government between \$9.00 and \$11.00 to produce and are less costly to use in some training exercises than the original M16 which sells for \$180.00.

Urethane elastimers are very sensitive to moisture so we put nitrogen gas in the containers to help absorb the moisture. Urethanes must also be mixed thoroughly to get the proper cross linking of the A & B components. If mixed by hand you will mix in a lot of air and this will lead to an inferior product. We therefore, use a machine to mix our components. Elastimers have about a 20 minute pot life and if mixing by hand you may not get the material thoroughly mixed before it starts to set up. If you mix by hand you must also try to vacuum out the air that you have induced

into the material. During the handmixing and vacuuming you have lost valuable time. If the urethane starts to set up before you pour it into a mold the part will not have good detail and you will have an inferior product. Demold time for parts will run about six hours. The exotherm in urethanes is very low therefore, urethane materials are easy on RTV molds.

#### 4. POLYESTERS

Polyesters, which we utilize for some parts has a high exotherm and the heat created from polyesters can be very hard on molds. The demolding time of polyesters is usually fifteen to twenty minutes. Polyesters do not have the elasticity of the urethanes, but the demold time is faster and to keep the exotherm down we load the polyester resin with hydrastone or filler. This in some instances also strengthens the material.

#### 5. URETHANE FOAM

Urethane foams also have a place in Training Aids. When it becomes necessary to reproduce an item that would be to heavy to handle easily, the foams have been very convenient. In a Terrain Map for example the urethane foams will give us all the detail of the 3 dimensional terrain map and also be very lightweight. Once the mold has been made we are able to reproduce four models that are 3' X 5' in one day. Symbols, Flags etc can be placed on the Map with a thumb tack or straight pin and will not damage the surface. We also fabricate mannikins from rigid urethane foam. They are produced from a 6 lb per cubic foot density foam. When they are completed they weigh approximately 40 lbs. Another item made from foam is the mine. An RTV mold is sprayed with a cellulose nitrate base paint and the foam is thoroughly mixed and poured into the mold. The paint adheres to the foam and when we have removed the part from the mold, we have a smooth painted surface. Some of our fancy plaques are also made from foam. In order to fabricate these we make a plaque from a piece of porous walnut wood and use this for our plug or master. The RTV rubber will pick up all the grain in the wood and when we reproduce our plaques from foam it has the appearance of being fabricated from wood.

To receive the full benefit from the expansion of the foam it must be mixed thoroughly and at a high rate of speed. The part can be

removed from the mold in approximately 45 minutes

One of our finest Training Aids is our 2 to 1 scale M16 rifle. To fabricate this rifle we have incorporated vacuum form parts cast in RTV molds, and parts machined from thermoplastic materials. The stock and forend of the rifle was vacuum formed from .157 thousandths translucent UVEX. Most of the receiver parts were machined from Lexan. The parts on the inside are all color coded for identification purposes. The rifle will feed a round into the chamber, and it will also extract and eject the round from the chamber. Because the rifle is transparent you can observe all the parts function. We also build the M60 machine gun in a 2 to 1 scale using translucent materials. All the parts operate on it and are also color coded.

Our machine shop is fairly well equipped and in the near future we hope to become involved in injection molding. Our plans are to purchase a machine that is capable of shooting 32 ounces.

#### 6. CONCLUSION

As I hope I have shown you, we are involved in many areas in the plastic field and are learning every day. It is a very challenging field that is always interesting and who knows what we will be asked to fabricate tomorrow.

Thank you.

#### 7. BIOGRAPHY

Schooling: Two years Jr. College in designing and engineering and metallurgy in Denver, Colorado. Also worked three years in a tool and die shop in Denver. Background in electronics. Have been attending Plastic courses at Georgia Tech. for the past five years.

At present employed at Fort Carson, as an Engineer Technician-Plastics.

## TAKING THE MYSTERY OUT OF PLASTER

Thomas L. Ravins  
Georgia-Pacific Corporation  
Gypsum Division  
Portland, Oregon

### Abstract

The most common variable in Gypsum Cement is setting time. If a better understanding of this property is developed by the user, a high percentage of trouble encountered in the use of fast or slow setting plaster can be averted.

The many possible modifications of Industrial Gypsum Cements have brought its application to fields where ordinary plasters were formerly used, and it has replaced wood and other types of pattern and model raw materials because of its high strength and ready utility.

Little is known of its complexities and reactions. A brief explanation of the most important one, setting time, may bring about a better understanding of its uses and limitations.

Plaster, or gypsum cement, has been used for pattern, model and mold making for thousands of years.

Gypsum, the basis for gypsum cements, is a mineralogical term derived from the Greek word "Gypsos", meaning chalk. Its use dates back to the early Egyptian dynasties, and its chemistry is generally credited to Lavoisier in the 18th century. It is from the mines and plants in and around Paris that the term "Plaster of Paris" was coined.

The first recorded discovery in the United States was in upper New York state in 1792. Benjamin Franklin, while ambassador to France, learned of its use as a fertilizer, and on his return introduced it to the farmers in this country. It is now mined and quarried throughout various locations in the United States, Canada and Mexico. The purest form for industrial use is found in deposits in Kansas and Oklahoma.

Chemically, it is calcium sulphate dihydrate  $\text{CaSO}_4 \cdot 2\text{H}_2\text{O}$ . Its chemical makeup in its purest form is:

Calcium Oxide	32.6%
Sulphur Trioxide	46.5%
Water	20.9%

Gypsum, in its crystalline form has two molecules of water combined in the lattice structure. Removal of 3/4 of this combined water by calcination

or heating converts it to calcium sulphate hemihydrate  $\text{CaSO}_4 \cdot \frac{1}{2}\text{H}_2\text{O}$ , or plaster.

There are two forms of calcium sulphate hemihydrate, the alpha form and the beta form. The beta form is the most common, produced by heating powdered gypsum in large kettles at atmospheric pressure to remove 1-1/2 molecules of water from the crystal. The alpha form is produced by heating sized rock in autoclaves or in a chloride solution, and is the one familiar to pattern and model makers, under the various trade names of Densite, Denscal, Hydrocal, and Ultracal gypsum cements.

During the early 1950's, these products emerged as a variety of specialized plasters for specific industries, including automotive, aircraft, foundry, ceramics, and plastics. Through technology and development, products were further designed to meet individual shop requirements. Among these requirements were control of strength, hardness, density, plasticity and setting time.

The manufacturer can change these properties with the addition of accelerators, retarders, and chemicals to control expansion and viscosity. The user need only add water, mix and cast. The manufacturer takes care to control uniformity from batch to batch and bag to bag. However, the product is susceptible to change through improper storage, exposure to high humidity, and reaction with soluble salts in water in certain areas.

The most common and by far the most critical change is setting time. If a better understanding of this property is developed by the user, a high percentage of trouble encountered in the use of fast or slow setting plaster can be averted. Perhaps a brief explanation of the theory of setting time will assist in this understanding.

The mechanism of setting at time of use is a reaction between water and plaster. At first

sight this reaction appears to be a simple one, although we know from experience this appearance of simplicity is deceptive. Many theories have been developed over the reaction which takes place, and the most accepted one is recrystallization. When the plaster is mixed with water, an induction period begins, measured by an increase in temperature. The resulting mixture then passes through stages of supersaturation and recrystallization to form an interlocking crystal mass characteristic of set plaster.

Some physical factors, such as percent mixing water, temperature of mixing water, amount of stirring, size of particles, age after calcining and age after grinding have an effect on the time of set. Calcined gypsum is very sensitive to the effect of some accelerators and retarders, and in some cases both the hardening action and the end product are quite different than in others, even though the setting has been retarded the same amount in each case. It is my purpose to give a summary of the effects of admixtures on a time of set, and advantages or disadvantages of such admixtures for certain desired effects.

Accelerators. Certain inorganic salts increase the solubility of calcium sulphate in solution. They also accelerate "time of set". Such accelerators are soluble halides and salts.

Another type of accelerator is one having the same crystal form as gypsum. The presence of such a material promotes crystallization without requiring the usual degree of supersaturation. Gypsum itself is an example of this type of accelerator.

Retarders. Commercial retarder, glue, casein, tanic acid, and sodium citrate are the most effective retarders. For instance 0.2% of commercial retarder will increase the time of set 2-1/2 to 3 hours. It is believed that such substances act as protective colloids.

Alcohol, sugar, and soluble citrates decrease the solubility of calcium sulphate and retard the time of set.

Retardation of set is by far the most serious problem occurring in the use of plaster or gypsum cements in the pattern and model industry. Some observations made on the physical properties as a result of this problem are strength and hardness. Retarders have a decided weakening effect. A certain amount of water is essential for the proper hardening of plaster or calcined gypsum. More water than is thus required is always added in order to properly mix the material for use. If the set is delayed too long, some of this water is lost by evaporation, and some is removed from the field of action by rising to the top of the cast. There is also the possibility that organic colloidal retarders may coat some of the grains of calcined gypsum and prevent the water from reaching them. The net result is a loss of strength.

Shrinkage. The tendency of retarded plaster or

calcined gypsum to settle out before it hardens has a decided influence on the shrinkage of a casting. Unretarded gypsum expands when it sets, a fact familiar to everyone. But if the same material is heavily retarded, there is a shrinkage from the original volume of the plastic mixture. In this case you may get a harder, denser material but it would not be suitable as a casting plaster.

The after effect of hardened plaster by the addition of accelerators and retarders is very important. Salts of sodium, magnesium, and iron have a tendency to cause efflorescence on the set material, no doubt due to the formation of their corresponding sulphates. This may not be serious if small quantities of such salts are used, but is liable to give trouble if large quantities are present. Acid and acid salts cause a swelling and formation of large pores in the plaster. As probably all commercial calcined gypsums contain some calcium carbonate, the trouble is probably due to carbon dioxide.

It is now apparent that gypsum cements, although simple in chemical composition, can become complex if setting time is not properly controlled. The manufacturer places all available technology into the proper control of this physical property. If a change takes place due to improper storage or exposure to extreme weather and contamination, the user can make adjustments in setting time in the shop. Common accelerators and retarders readily available in most areas are:

<u>Accelerators</u>	<u>Retarders</u>
Ground Gypsum	Commercial Retarder
Potassium Sulphate	Sodium Citrate
Potassium Chloride	Sucrose

#### BIOGRAPHY

Thomas L. Ravins, Product Manager for Georgia-Pacific's Industrial Gypsum Products is located in their headquarters in Portland, Oregon. He has been involved in the chemistry, formulation, sales and practical application of Industrial gypsum products since 1955. A graduate of St. Benedict's College, he holds a B.S. in Chemistry.

## H. T. EPOXY TOOLING RESINS WITH IMPROVED HANDLING AND SAFETY CHARACTERISTICS

Wm. Romey, Sales Representative  
Furane Plastics, Inc.  
Sub. of M&T Chemicals Inc.

### Abstract

This presentation will explain the improved handling characteristics and safety advantages of new low toxicity, high temperature tooling systems. The influence of proper curing procedures on final high temperature tool performance is also discussed.

### 1. INTRODUCTION

The use of high temperature tooling resins has been inhibited by certain characteristics associated with those materials such as toxicity, the tendency to stain hands and clothes, disagreeable odors, and elaborate high temperature cures. Recent development of a new class of high temperature resin systems either overcomes or minimizes these restrictions; thus stimulating new interest in the area of high temperature resins.

We propose to examine the advantages of these new resin systems, i.e., low toxicity and improved handling, in addition to associated physical properties and examples of applications of these materials.

### 2. LOW TOXICITY

With the advent of the Occupational Safety and Health Act (OSHA), industry is becoming increasingly aware of potential safety hazards associated with epoxy resins and catalysts. The Society of the Plastics Industry (SPI) has recognized these safety problems and has produced a guide which clarifies the toxicity potential of products for the benefit of the industrial user. The hazard category is given in terms of degrees, as follows:

- Class 1 - Practically non-irritating
- Class 2 - Mildly irritating
- Class 3 - Moderately irritating
- Class 4 - Strong sensitizer
- Class 5 - Extremely irritating
- Class 6 - Suspected carcinogen in animals.

Because of this increased awareness, resin formulators regard safety as important a criterion as strength and tem-

perature resistance when considering a new resin system.

One resin system, EPOCAST 21-A/B, which is representative of this new class of high temperature resins, was developed with the objective of obtaining the lowest toxicity possible without sacrificing high temperature properties. All components which make up this resin system have an SPI classification lower than Class 3. As a result, this system is classified SPI 3. This is a significant point in that the vast majority of all high temperature epoxy tooling systems have an SPI classification of 5 or 6. Reduced toxicological hazards are a direct benefit when using this new class of resins as compared with most existing high temperature resins. Good safety and housekeeping procedures should be used with these materials, regardless of the low toxicity, as infrequently an individual shows an allergic reaction. This occasionally appears after repeated or prolonged contact with the hardener.

### 3. IMPROVED HANDLING

In addition to the low toxicity, improved handling is another characteristic identified with the new systems. Two factors which are directly a part of handling are hand stain and odor. While these factors are not considered as serious as toxicity ratings, they are important to the man using the materials. Many of the good quality high temperature tooling systems on the market today stain the skin and clothes, and have strongly disagreeable odors. The new systems do not have hardeners based upon aromatic amines and, therefore, have no skin stain effect, and low odor.

Another factor of handling is workability. Workability is a

highly subjective concept involving viscosity, thixotropic properties, the ability to be easily mixed, pot life, the ability to wet out cloth, and many other characteristics. There is no established method of qualifying workability and, because of the subjectivity, the new system cannot easily be compared to existing high temperature systems. In actual usage, however, most shop people are very pleased with the workability of these new systems.

Elaborate high temperature cures are required for many of the high temperature tooling resin systems currently in use. Another improved handling feature of this system is a simple cure cycle: one hour at 250°F. and one hour at 350°F. is normally all that is required to attain full properties.

Table I identifies the handling characteristics of a typical low toxicity system.

#### 4. PHYSICAL PROPERTIES

It is quite obvious that the advantages of safety and improved handling would be only academic if the physical properties were not such as to provide required performance. Table II shows typical properties developed from a representative new low toxicity resin system. In addition to the properties shown it would, perhaps, be helpful to elaborate upon the concepts of heat distortion, shrinkage, mark-off, and physical properties at temperature.

##### 4.1 Heat Distortion

It is clear that there are many opportunities for non-metallics in tool fabrication, particularly if temperatures are under 350°F., and it is to these areas that the new safety systems are directed. Useful criteria are found in ASTM heat distortion temperatures which are measured under flexural stress at increasing temperatures. Although resin systems are usually screened and compared without benefit of glass cloth reinforcement, most suppliers of H.T. epoxies base comparisons on cured, laminated systems--the usual structure of an H.T. tool. Laminates do show considerably higher heat distortion temperatures (H.D.T.) than resin systems without benefit of reinforcement. For a given system, the influence of state of cure and the influence of prolonged heat aging will alter H.D.T.

##### 4.2 Shrinkage

Another advantage of glass reinforcement in high temperature tools is its ability to greatly reduce shrinkage during cure. The cure shrinkage of resin as compared to the same resin reinforced with glass fabric is very substantial. Uneven shrinkage is related to warpage of the laminated jig and fixture, particularly if one surface is resin rich and the opposite surface is low in resin content. Tool fabricators must achieve a proper distribution of

resin and its reinforcement of fabrics to minimize warpage.

##### 4.3 Mark-Off

A loose term used to describe impressions formed on the molding face of an H.T. tool is mark-off. It is not a significant problem for holding jigs such as welding fixtures, but a serious problem for matched non-metallic dies or vacuum molds. Materials which retain hard Durometer readings at high temperature or which, if marked-off by the coarseness of a fabric weave, demonstrate good elastic or "spring-back" qualities rather than the effects of flow or creep in the face of the non-metallic tool, will have good mark-off resistance. This is a practical measure of quality of high temperature tooling.

##### 4.4 Physical Properties at Temperature

The fundamental criteria on which high temperature tooling materials should be selected are the available strength and moduli of the laminates at temperature. These comparisons must be tempered by an understanding of heat distortion temperatures, shrinkage, and mark-off of H.T. tools.

#### 5. APPLICATIONS

High temperature epoxy resins have been used for many years for low cost reliable tooling. Over these years the required service temperatures have been steadily increasing. Today there are applications where the resin systems must have heat distortion points in the 450-500°F. temperature range. For applications in this temperature range, systems are being developed which have the same safety and handling characteristics as described previously; an example is EPOCAST 41-A/B. The subject of this paper, however, is the safety systems which have been perfected and are in use. These systems operate comfortably in the 350°F. range.

The following list shows applications where the new low toxicity resin systems would be more than satisfactory.

- a. Plastic Laminating Molds. The hand lay-up of epoxy, polyester, or phenolic prepreg or "A" stage materials with cure temperatures of 250-350°F. Contact, atmospheric (vacuum bag), or autoclave pressures could be used. Most tools are glass fabric impregnated with high temperature epoxy resin systems behind a gel coat face.
- b. Bonding Fixtures. The adhesive assembly of metals and/or plastic structures requires the application of modest pressures (5 to 10 psi) at temperatures sufficient to cure the adhesive, usually 250-350°F. Glass fabrics laminated with H.T. epoxy systems satisfy the needs of most H.T. bonding fixtures.
- c. Molds for Urethane Foams. The preparation of shaped urethane foam structures requires a mold capable of

withstanding exotherm temperatures developed by the self-foaming resin system. It is doubtful that the skins reach temperatures over 300-350°F.

- d. Injection Mold Inserts. For short production runs, plastic molds cast about accurate models and fitted into steel reinforcing frames or chases, obviate the necessity for cost consuming machine time. These plastic molds are best prepared from high temperature epoxies. Pressures and temperatures may be high for the injection molding process (up to 450°F.) and only a limited number of resins will satisfy these needs.
- e. Vacuum Form Dies. The forming and shaping of pre-heated thermoplastic sheets are important applications for the fabrication of both small and very large parts. The thermoplastic sheets give up their heat to the molds while cooling, and some cooling provisions must be provided. Temperatures are usually in the 300-350°F. range. H. T. epoxy vacuum forming molds (parts are formed under vacuum pressure) must compete with cast aluminum molds.
- f. Matched Non-Metallic Dies. Limited production of semi-cured, resin-impregnated fabrics into finished articles using steel mold construction is too costly. Some success has been experienced in using reinforced H. T. epoxy molds, usually at temperatures up to 350°F. Two halves, mated with appropriate

pins or dowels, are used. Matched metal molding of impregnated fabrics with resin binders of polyimides, polybenzimidazoles and others, will find available plastic molds very limited because of high temperature and high pressure (up to 100 psi) requirements.

- g. Foundry Core Driers. Support of oil or resin bonded sand cores in the drying oven for foundry uses may make demands on H. T. plastics for fixture supports. Very few materials are available to withstand long hours of service up to 500°F. as cores pass through ovens for drying. Phenolics, high temperature epoxies and drying oils are more frequently used.
- h. Welding Fixtures. Heat from welding or brazing tools may be shielded very comfortably by H. T. epoxy jigs and fixtures. Requirements are not too severe, and opportunities abound in this area.

## 6. CONCLUSIONS

The classification of resin systems discussed above provide the latest advancements in safety and performance which are expected of today's high temperature tooling resin systems. For the specialized application where 400-500°F. operation temperatures are expected, new systems are being developed which offer an SPI Class 3 rating and the improved handling characteristics.

TABLE I  
HANDLING CHARACTERISTICS - LOW TOXICITY SYSTEM

Viscosity, Resin, EPOCAST 21-A, light gray Hardener 21-B, amber colored	5,000 - 6,000 cps at 77°F. 1,000 - 2,000 cps at 77°F.
Mix Ratio	100 parts by weight EPOCAST 21-A 15 parts by weight Hardener 21-B
Work Life	2-3 hours at 77°F., 100 gram mass. Work life will be less if material is at higher temperature.
Cure	Stage curing is advisable to produce best part. Typical cure would be one hour at 250°F. plus one hour at 350°F.
SPI Class	3
Skin Stain Effect	None
Odor	Low

TABLE II  
PHYSICAL PROPERTIES - LOW TOXICITY SYSTEM  
 Cure: 1 hour at 250°F., 1 hour at 350°F.

<u>Property</u>	<u>Results</u>	<u>Test Method</u>
Specific Gravity, gm/cc, 21-A 21-B	1.15 ± .05 1.0 ± .05	ASTM D-792
With No. 7500 glass fabric laminate (heat cured) (Volan A finish, 8 ply, hand lay-up)		
Flexural Strength, psi, 77°F. 300°F.	40,000 25,000	ASTM D-790
Modulus of Elasticity in Flexure, psi 77°F. 300°F.	2.1 × 10 <sup>6</sup> 1.6 × 10 <sup>6</sup>	ASTM D-790
H.D.T. of Laminate, °F.	400	ASTM D-648
H.D.T. resin system alone, °F.	310-320	ASTM D-648
Thermal Expansion Coefficient in/in/°C.	2.5 × 10 <sup>-5</sup>	ASTM D-696
Durometer D Hardness, min.	90	ASTM D-2240

## "BASICS OF PLASTIC TOOLING"

by

L. E. Winter

Ren Plastics Div., CIBA-GEIGY Corp.

LAMINATES IN TOOLING

The most widely used method of tool fabrication involves the use of fiberglass reinforcement (in the form of cloth, matting, or chopped strands) which is impregnated with a resin system.

Most tool makers prefer to have smooth face on the finished tool and this requires a gel or surface coat. Gel coat epoxy resins are usually of paste consistency and are applied to the prepared pattern with a short bristle brush or squeegee. Care must be exercised when applying the gel coat to avoid entrapping air bubbles.

The application of the fiberglass reinforcement may begin as soon as the gel coat has become "tack free". This is the point when the gel coat may be lightly touched with the finger without having any of the resin sticking to the finger. Once the gel coat is tack free, brush a coat of the laminating resin over the entire surface. If a layer of glass cloth were to be applied directly to the gel coat, it would, in all probability, stick to the gel coat and tear it loose. A coat of laminating resin will allow the tool maker to move the glass cloth without danger of ruining the gel coat.

As the layers of glass cloth are applied, each should be preceded by brushing on a coat of laminating resin. By applying dry cloth over the coat of laminating resin, a much more air free laminate will be produced since the glass cloth will act as a wick; the resin will push all air ahead as it wicks its way up through the glass cloth. Continue this procedure until the desired thickness is reached.

Larger laminated tools will require exterior reinforcement of some type to help retain configuration. Reinforcement selection is determined by the tool use, economics, and temperature ranges the tool will be subjected to.

Tools for use at room temperature and at slightly elevated temperatures (up to 350° F) are usually treated just as any normal laminated tool; however, tools which will be operating at 400° and above should be vacuum bagged during cure to remove all excess resin. Vacuum bagging will produce a tool with more uniform distribution of resin and glass cloth, hence, a tool more capable of withstanding thermal cycling.

CAST TOOLS

Because of cost and general brittleness, tools which are entirely of a cast epoxy resin are usually small in size. This method of tool construction is obviously the easiest and fastest way to build a tool. Simply mixing the resin and hardener and pouring into the prepared pattern can produce a tool if one or two basic principles are remembered.

Follow the resin manufacturer's recommendation for maximum thickness to which the resin system may be cast; exceeding this maximum thickness will only cause excessive shrinkage and warpage of the tool. There are resin systems which are designed to be cast in all thicknesses. Cast resins shrink during cure and will predominately take this shrinkage from the open side of the pattern. Small metal form dies, hydropress form dies, chucking jaws and holding fixtures have been successfully fabricated with cast epoxy resins.

Another widely accepted use for casting resins in tooling is that of producing prototype parts; small intricate shapes are easily reproduced by casting. One manufacturer builds each prototype camera entirely of cast epoxy resins. After the prototype has been approved for production, the unit is disassembled and the parts used for master patterns.

#### SURFACE CAST TOOLS

When a solid cast tool becomes too expensive, or when the stress in the tool will surpass the normal properties of the epoxy resin, the fabricated tool should have only the working face of cast epoxy.

A core is fabricated with the face 1/2" to 1" back from the desired contour. The prepared pattern is then spaced from this core, all edges are sealed off (except for pouring and venting spouts), and the epoxy is cast between the core and pattern to form the face over the core. Cores in the aerospace industry are usually constructed of kirkcaldie or aluminum.

#### AGGREGATE

Tools which have high compressive strength and in some cases, high ability to conduct heat, are constructed with a core of epoxy resin blended with various aggregates such as aluminum, crushed rock, or other inorganic materials. A gel coat is used to impart a smooth surface to the tool, and after the gel coat has become tack free, the core material is prepared and packed behind the gel coat.

When great compressive strength is required of the tool, the ratio of resin to particle may be as low as two parts of aggregate to one part epoxy resin. Prototype injection dies and limited run compression mold dies are built using this ratio of epoxy resins with an aluminum particle. This same type of construction has been used for years to build molds for vacuum forming thermo plastic sheet material. For vacuum forming molds, the ratio between the aggregate and resin is raised to around five parts of aggregate to one part of epoxy resin. This ratio will produce a core which is porous. The drilling of vacuum breath holes is then limited to just drilling through the gel coat, since the entire core acts as a vacuum chamber.

#### TOOLING WITH A SPLINE

Although building master patterns with templates and splined contours is not new, it has taken the epoxy resin formulators many years to develop resin systems which will have the "feel" and "drag" of plaster. Building master patterns with the contours splined with epoxy resins offers many advantages, the greatest of which is the permanence of the surface and resistance to weathering and mechanical damage. Techniques employed in splining epoxy resins are similar to those for splining with plaster materials.

Epoxy pastes have been used for years to patch and repair thousands of items, from water valves to concrete blocks, but some of the newer uses of epoxy paste are great assets to the tool builder who needs duplication of contour in limited areas.

Jig pads and contour boards formerly required many hours of hand grinding to obtain an accurate duplication of a compound surface. Utilizing epoxy pastes in this application involves fabricating the basic jig pad or contour board to approximate contour and then spacing it away from the contour master. Epoxy paste resins are then forced into the gap between. Because it is of a paste consistency, the epoxy will not run out, and will exactly duplicate the contour.

#### RELEASE AGENTS

Because of the excellent adhesive qualities of epoxy resin, it is necessary to employ release agents on patterns used in plastic tooling.

Of the wide variety of materials used for patterns, nearly all require either different release agents or methods.

- (1) Plaster must be thoroughly dried (8 hrs. at 150°F) and sealed. Clear laquer cut 50-50 with thinner is the best sealer. Do not use shellac. After sealing, apply a generous coat of paste wax and wipe off excess. After remaining wax is dry, it should be lightly buffed. Follow this with a spray coat of PVA or PVC to achieve desired gloss.
- (2) Plastic and metal patterns may be treated in the same manner and usually require only a coat of wax. Silicone release or TFE type release may also be used.

- (3) Wood is the most difficult because of grain and gassing tendencies. Generally follow the procedure outlined for plaster patterns. If in doubt, contact your resin supplier.

#### MIXING RESINS

Misunderstanding of the difference between epoxy and polyester resins has caused many tool failures. Polyesters start to cure the day they are manufactured. Adding a catalyst only speeds up that which is going to happen anyway. Epoxies, on the other hand, will never solidify until they are mixed with their hardener. Epoxies rely on a chemical cross-link with a hardener in a precise ratio. If the mix ratio for an epoxy is listed at "100 to 10", each molecule of hardener will cross-link with ten molecules of resin. Putting more hardener into the mix will only cause an excess of molecules with nothing to react with and will remain liquid.

Thorough blending of resin and hardener is very important. Generally the density of epoxy resin is higher than the mix of epoxy resin and hardener. Because of this, any un-mixed resin will settle to the bottom of the casting and cause soft spots on the tool face.

Thorough blending consists of:

- (1) Hand - Use a sturdy paddle, mix for 5 minutes stopping at least twice to scrape sides, bottom and stirring paddle.
- (2) Power - Mix 2 minutes at 1800 RPM with a propellor type mixing blade, minimum. Stop during mixing to scrape sides and bottom.

#### DE-AIRING RESINS

Some castable resin systems, notably polyurethanes, require de-gassing or de-airing in order to achieve high quality castings. After blending, but before gellation, the resin system should be subjected to repeated short exposures to vacuum. Three or four times of rapid vacuum build up and collapse will usually de-air any resin system.

#### TRIMMING AND FINISHING PROCEDURES

Trimming fiberglass laminate tools is usually accomplished through the use of a diamond rotary saw or a band saw. In the case of band saw use, follow the recommended feed and speed rates for aluminum. Carbide blades are recommended. Final dressing to finished trim is usually done with a rotary disc sander followed by hand filing.

Drilling speed and feed rates of aluminum are used. It has been found that an increased clearance rake angle will aid in cooling the drill bit.

Because of the highly abrasive nature of fiberglass, carbide and diamond tools are suggested where ever practicable.

N75 13981

D420159

PL-22660

QUALITY CONTROL & PRODUCT DESIGN  
IN A HIGH-VOLUME FRP MANUFACTURING PLANT

William E. Clow, BSc.  
Kimstock, Inc.  
Santa Ana, California

Abstract

Essential standards for producing a profit in the highly competitive FRP manufacturing business. Attainment of growth through a rigid quality control program and cognizance of the essentials of good product design.

This presentation will not be highly technical. The purpose is to outline what are considered to be essential standards for producing a profit in a highly competitive business. Most of the presentation will be centered around Kimstock, Inc. tub-shower production plant in Santa Ana, California. Since its acquisition by Tridair Industries in 1969 Kimstock has increased its volume from less than 100 parts per day to over 500. This growth would not have been attained profitably without a rigid Quality Control Program and cognizance of the essentials of good product design.

Product design. Kimstock utilizes the services of an industrial design consultant to prepare conceptual drawings and ultimately the final design. All pattern work is done by outside professional pattern makers. The cost to make the design, patterns, and master molds is approximately \$8,000 for a pair of right and left tub/shower units. Production molds cost \$800 to \$1,200 each. A sanitary fixture design must not only be aesthetically pleasing, but it has to satisfy building code requirements and the needs of production. This leads to compromise--usually at some expense to aesthetic values. It is a rare contractor who will guarantee enough volume to pay off mold costs. This infers that most new designs be carefully developed for wide acceptance.

All fiberglass plumbing fixtures sold in the United States are required to meet American National Standards specifications. Regional or local jurisdictional approvals are generally contingent upon having approval and listing by the International Association of Plumbing and Mechanical Officials or the Southern Building Codes Congress. Their provisions include USAS standards. Consideration must also be given to meeting specifications promulgated by FHA, BOCA, and ICBO. Basic requirements cover strength, sanitation, drainage, area and durability.

In developing a new design, Kimstock is especially concerned with minimizing the possibility of mold damage and avoiding part repair. This requires adequate draft so that the part pulls easily from the mold and avoidance of sharp radii wherever possible. Sharp radii create stress points and require pre-filling or very careful rolling of the glass and resin so that the gel coat is properly supported. Inattention to this detail can increase overall labor costs as much as 25 percent in a high-volume shop. Low-volume shops have the same problem but it is easier to control the process with fewer people and parts to contend with.

Quality control. In a high-volume shop all raw materials must be rigidly controlled. Faced with today's shortage of plastics material, this is not easy to control. If the material is slightly off "spec" the buyer cannot easily get substitute material even though the manufacturers are very cooperative.

In the fiberglass tub/shower field, the finish must comply with USAS specifications Z124.1 and 124.2. Gel coat is required to pass scrub, boil, impact, porosity, tensile, and wear tests as well as satisfy the manufacturer's performance tests for production purposes.

On an automated line it is very critical that materials perform within narrow limits. Consequently, Kimstock subjects every batch of gel coat and resin to a series of tests before acceptance. These include testing for particle size, gel time, gel to peak temperature, viscosity, and porosity. Porosity is a significant item as it cannot be detected on a part until it is pulled from the mold, which means there could be as many as 30 or 40 parts in process that need rework. Gel time is so important that Kimstock inventories gel coat with different gel times. One material is formulated for normal air temperatures and the other for colder temperatures encountered early in the day and late at night. When gel coat is not cured adequately, the line must be slowed or transfer will occur. "Transfer" is a term used to indicate that the glass fiber pattern is visible from the outside or finished surface. This is caused by the fibers being pushed into the gel coat by the rollers as they work the glass-resin mixture so that all fibers are properly impregnated. Transfer can also occur from resin that is off "spec."

In addition to material tests, Kimstock employs an extensive on-line quality control program, approved and monitored by the NAHB Research Council.

Gel coat thickness is generally controlled by making wet film gage tests as the part is sprayed. Resin and fiberglass

thickness is checked by a probe carried by the chopper gun operator and the line inspector. Material usage is also carefully monitored by taking a daily inventory and comparing it to the number of square feet of the parts produced. A full-time air checker is used to make sure that material is rolled out properly and that there is no area where the gel coat is not adequately supported. When the part is pulled, every unit is weighed to determine if too little or too much material is being applied. An inspector works next to the puller station to check every unit. Any point requiring repair is marked on the unit and the location is checked on a layout sheet that stays with the part until it passes final inspection.

In compliance with NAHB and IAPMO requirements, units are also subject to further tests on a statistical basis. Once a month, on a random basis, an independent laboratory service conducts field tests for NAHB. Tests include porosity checks, burn tests, material thickness and deflection tests. Periodically, samples are cut from a unit and sent to the NAHB Test Laboratory for detailed analysis. Glass to resin ratio is determined by burning off the resin and weighing the residue. This test is conducted by the NAHB Laboratory and our resin supplier.

Biography. Mr. Clow is a graduate of the University of British Columbia with a Bachelor of Applied Science degree in mechanical engineering. His background includes many years in manufacturing of wood, metal, and plastic products. He is Chief Engineer and Manager of Procurement for Kimstock, Inc., a division of Tridair Industries. He spent five years with Tridair as corporate Facilities Engineer. In that capacity he was responsible for design, layout, and construction of their large plant in Torrance, California which has a fiberglass shop for production of structural containers for the air cargo industry and motorcycle accessories. Kimstock, Inc. produces fiberglass tub-showers as well as specialty products such as chemical toilet shelters and concrete forms.

## RESINS SCARCE? MAKE TOOLS AND PARTS WITH SOLID WASTE AND CONGLOMERATE-COMPOSITES.

By Edwin F. Bushman, Plastics Engineer, and Bruce E. Bushman, Physicist

### ABSTRACT

Petrochemical feedstock shortages have plagued the resin and fabrication industry in 1973-74, causing fabricators to cast about for ways to stretch short supplies of thermoset and thermoplastic resins for molds, tools and parts, and to preserve jobs. This paper suggests ways the scarce resins may be combined with readily available solid aggregates, fines and powders, to make useful solid molds or products. Low density and biodegradable organic agricultural wastes and products, solid metallic and nonmetallic wastes, and discarded materials of construction and industry are shown to have use in making inexpensive and serviceable "conglomerate composite" tools and parts. Types and sources of solid and low density wastes for plastics uses are discussed, along with ecological benefits. Emphasis is also placed on use of local or native mineral, earth, rock, forest and agricultural materials by plastic workers in remote or underdeveloped regions of the world, distant from industrial and machine tool centers.

In simpler times the catch-all term "plastics tooling" sufficed to cover any type of cast, filled or laminated molds and tools of resinous nature. Extenders proposed are widely varied, and the authors propose generic nomenclature for highly filled resinous tools and parts:

- "conglomerate-composites" for mixed fillers,
- "bio-composites" for biodegradable fillers,
- "rock composites" for mineral, sand, earth, and rock fillers,
- "metal-composites" for metallic fillers,
- "wash-composites" for water soluble fillers.

By stressing principles of high packing of solid particulate matter to achieve low volume void (resin) content of the cast conglomerate-composite item, the authors indicate ways to stretch scarce and expensive resin supplies to build the most parts and make the most jobs with available skills.

### INTRODUCTION

Plastics resins for tooling and molding have suddenly become scarce and quite expensive. Causes are the large demand and severe shortages of petrochemical feedstocks. Thrift has been ridiculed by several generations of Americans,

accustomed to a wealth of raw materials and energy. The press roundly ridiculed a recent president as "Light Bulb Johnson" for his penchant for switching off unused lights in the White House. Today the president requests we do so because energy sources are badly overextended.

Thrifty ways to extend scarce resins with cheap and available fillers and reinforcements are now more important than ever. This paper discusses heavily filled and fortified plastics, the types and sources of fillers, and methods to reduce precious resin content of plastics tools and parts. Most fillers are commercial specialties, expressly manufactured for that purpose. Besides these commercial and well-known fillers, usually mineral, are some presently discarded as solid waste by cities, industries, and agriculture. These solid discards can be combined with a little resin or cement binder and made into useful tools or parts, benefitting both the plastics industry and the ecology.

### FILLERS ARE AVAILABLE EVERYWHERE.

Inorganics such as sand, mica, ground limestone, iron ore, bauxite, clay, adobe, talc, ground pumice, lava, decomposed granite, silt, graphite and many other mineral deposits are excellent fillers for plastics, as are glass spheres, glass microballoons, crushed ground glass, cinders and crushed smelter slag.

Organic fillers widely used in plastics compounding have been alpha cellulose fiber, kraft fiber, weed fibers, cotton fibers, wood flour, sawdust, wood chips, agricultural waste and fiber such as jute, bagasse, sisal, hemp, ramie, coconut, palm, etc. Organic fillers stressed for biodegradability besides the above are starch, wheat flour, and cereal grains. Special water soluble fillers are cane and beet sugar, table salt, and zein.

Fiber waste from textile processing has been chopped, macerated, carded, and compounded as fiber filler and reinforcement. Such fibers are cotton, jute (burlap), hemp (rope, twine), sisal, rayon, nylon, polyester, modacrylic, etc. Due to resin scarcity and high prices, formerly wasted thermoplastics are suddenly being collected as packaging and processing scrap, crushed, mixed with other waste fillers, heated, extruded, and made into useful objects or into pellets for molding. Modern Plastics (February 1974, pp. 38-42) states that the latter recovery of plastics waste from industrial processes will amount to 250,000 tons per year in the United States.

## FILLERS FOR ELASTICS TOOLS

This SPI Plastics for Tooling Conference emphasizes so-called "non-metal" tools. These are usually made by casting epoxy resins, sometimes with a little aluminum powder filler or needles, or by laminating epoxy or polyester resins with glass fiber. Past conferences have described cast plastic tools using many thousand pounds of epoxy resin. Today this seems extravagant, when resins are allocated or rationed to fabricators, such as 1/2 or 1/3 of 1972 purchases. New fabricators, with no 1972 purchasing history, are particularly pressed for raw materials.

One might reply that the obvious alternative to plastics tooling, if resins are scarce, is to return to metal tooling. Alas, metals are also scarce, because they require great amounts of energy for smelting, refining, rolling, extruding. The past drought in the Northwest reduced available hydroelectric power, making aluminum reduction by electrolysis possible only at a drastically reduced rate. The steel industry has dropped some important alloys and gauges commonly used in tooling. Shortages of normally abundant metal shapes and aggregates and powders again draw our attention to cast, "non-metal" tooling, which can be made with little matrix resin and a lot of cheap, solid waste castoffs from industry, agriculture, and cities. Some of these materials and the resulting composites are on display, and may be incorporated in your uses. They are listed in the tables. Since such a wide variety of fillers may be incorporated in a cast plastic tool or part, we have searched out new nomenclature. When a variety of fillers and aggregates are combined with resins or cements in a solid, we call it a "conglomerate-composite", like the rock classification of that name. If the fillers are mineral or rock, we call the result a "rock composite". If biodegradable fillers are the filler and aggregate, then the tool or part is a "bio-composite". Some of the fillers may be water-soluble as well, and are "wash-composites," disintegrating by solution. "Metal-composites" use metallics.

Many types of solid metal particles, aggregates and shapes are available as prime or solid wastes, and are listed in Table I. Nonmetal fillers are listed in Table II. IIIa to IIIc for "rock-composites," IIIa,b are for "bio-composites." Table II elaborates on expanded mineral and organic fillers and aggregates, which may be combined with resin or cement binder to make lightweight tool backup, or "syntactic foam" type of composite.

Tables III to VI list physical properties of some fillers and composites, as an aid to selection of materials for a specific

purpose. Properties of various ingredients will influence properties of the composite, although not always in direct proportion to percent composition, as in weight. Heat conductivity of a metal-powder filled resin is frustratingly poor, because the metal particles are surrounded by masses of resin which is a poor conductor of heat. Point contacts of metal particles will provide electrical conductivity, but very little heat passage. Methods of packing solid metal particles and aggregates have been researched by the authors, and will be discussed.

## SCRAP METAL AGGREGATES (See Table I)

Tool use of solid waste fillers collected from machine and mold shops, industry, lumbering, construction, mining, milling, smelting, agriculture, and food processing will benefit the national ecology. Instead of generating scrap and waste, as does the machining of a new tool in steel, metal/composite tooling can utilize solid wastes.

The metal finishing industry operates local shot blasting, tumbling and shot peening establishments for preparation of metal parts for plating and painting. This industry offers virgin metal, glass, and mineral abrasive particles in various sizes and shapes. Steel balls and rods, steel shot and crushed iron grit of assorted sizes are useful in casting a multi-sized metal/composite aggregate tool. Also, this industry disposes of waste shot and fines from the operation as trash. Useful metal/composite tools and molds have been cast from such metal-blasting waste.

## SYNTACTIC FOAM

Castable syntactic "foam" may be made by mixing hollow microballoons made of phenolic, sarax, epoxy, glass, or ceramic, with a catalyzed liquid bonding resin such as polyester, epoxy, or urethane, or an inorganic cement or plaster. Useful low density solids result, with controllable densities of from twelve to fifty pounds per cubic foot.

Useful low density syntactic "foams" have been made for bulkhead and sandwich core pouring or sprayup in double-hulled boat construction. In some of these mixtures, low density waste particles, such as ground nut shells, corncobs, pumice, wood, radiolarian, diatomaceous or foraminiferous earths may be incorporated to reduce costs. In tooling, such low density, rigid, solid syntactic "foam" provides strong tool backup or cavity fill. In hydrospace, the low density, solid syntactic foams of high compression strength are used as deep water floats and bouyant structures. Low density plaster and concrete mixes incorporate expanded minerals, such as perlite or vermiculite.

## PURCHASE SOURCES

### Metal Fillers and Aggregates

#### Aluminum powder, aggregate

Alcoa  
Reynolds  
Almeg  
Chase  
Anaconda  
Kaiser  
Alcan  
etc.

#### Copper, Brass powder, aggregate

Kennecott  
Anaconda  
Chase  
Calumet-Hecla  
Globe-Morenci  
Alcan  
etc.

#### Steel & Iron shot & grit, Steel balls, rods, cones

Pangborn-Carborundum  
Cleveland Metal Abrasives  
Pittsburgh Crushed Steel  
National Pulv. Metals  
Abbott Ball  
etc.

#### Magnesium Particles

Dow  
Alcoa  
Kaiser  
etc.

### Resins

#### Polyester (31 manufacturers)

#### Epoxy (10 prime)

Ciba-Geigy  
Shell  
UCC  
Dow  
Reichhold  
Celonese

#### Epoxy compounders (about 50)

#### Urethane compounders (about 20)

#### Gel coats

#### Polyester

Ferro, PPG  
Glidden  
etc.

#### Epoxy

Hysol  
Hastings  
Furane  
Ren  
etc.

#### Glass cloth (prime weavers)

Stevens  
UMM, Uniglass  
Burlington  
Hexcel  
Clark Schwebel

#### Glass mat (prime)

OCF  
PPG  
Ferro  
JM  
FG Inds.

#### Woven Roving

OCF

Clark Schwebel

Ferro

Kaiser

JM

Bean

King

Fiberglass Industries

Stevens

Uniglass

Burlington

Hexcel

## CHEAP FILLERS FOR LOW COST BACKUP IN TOOL- ING

### SURPLUS AGRICULTURAL COMMODITIES AND SOL- ID WASTES FROM MINING, INDUSTRY, CON- STRUCTION

Several hundred miles east of Vancouver, B.C., lies the beautiful wheat capital city of Regina, Saskatchewan. Alberta and Saskatchewan provinces provide most of Canada's wheat supply, and export thousands of tons to China and India.

We thumbed through a 1970 National Geographic recently and discovered that during the 1969 wheat glut, mountains of threshed wheat were allowed to rot out in the weather, because there was literally no market, even at \$1.50/2-bushel bag. A photograph shows a Regina rancher trading 2 huge bags (four bushels) of surplus wheat for 2 tickets to a Regina Roughriders pro football game. It occurred to us that many parts of the world, including USA and Canada, occasionally produce enormous supplies of surplus farm commodities and slightly spoiled or off-grade produce and waste products, such as grains, nuts, pods, beans, seeds, and pits, which have no value to the producer or processor. But to an ingenious plastics or tooling engineer, these waste farm products can be converted with resin bonding into molds, tools, light weight tool backup, structural sandwich core castings, etc., using metal/composite molds. Our exhibit illustrates such fillers in castings.

Following is a list of farm supplies and products which often have little or no value as (a) surplus supply, (b) off-grade (c) spoilage, or (d) processing discard. Combined with resin binder, light weight structures result. Drying and treatment against rodents is advised before casting. (Rats will eat hard plaster objects containing starch, while dogs ate the 1936 Illinois license plates made of soy bean plastic.) Glass fibers are universally used in skin laminating of resinous tooling, but agricultural fibers are also useful.

**TABLE II. WASTE, CHEAP FILLERS AND BACKUP AGGREGATE**

**A. BIODEGRADABLE FILLERS**

Beans, dried  
Pinto  
Blackeye  
Fava  
Coffee  
Cacao  
White  
Red  
Kidney  
Lima  
Garbanzo  
Soy  
Kuhui  
Celluloses  
Wood chips  
Pine needles  
Vegetable fiber  
Tree bark  
Ground corn cobs  
Ground fillers  
Sawdust  
Wood flour  
Apricot shell  
Walnut shell  
Peach shell  
Cornmeal  
Cracked wheat  
Arrowroot  
Maise  
Starch  
Sugar  
Salt  
Cereal grains  
Wheat  
Barley  
Oats  
Rice  
Sorghum  
Corn  
Milo  
Sunflower seeds  
Miller  
Pumpkin seeds  
Wood seeds  
Nuts, unshelled  
Walnuts  
Pecan  
Hazel  
Brazil  
Pistachio  
Almond  
Acorn  
Coconuts  
Peanuts  
Processed grains  
Expanded wheat  
Expanded rice  
Peppered corn  
Pods, seed  
Pine cones  
Eucalyptus pods  
Waste Products of canners, processors  
Peach pits  
Date pits  
Apricot pits  
Cherry pits  
Olive pits

Grape seeds (pomace)

**B. AGRICULTURAL FIBERS (BIODEGRADABLE)**

Bagasse  
Jute  
Sisal  
Hemp  
Ramie  
Coconut  
Silk  
Cotton  
Wool  
Animal fiber, bristle  
etc.

**C. NONBIODEGRADABLE FILLERS**

Mineral Fillers  
Large aggregates  
Gravel  
Coral  
Sea shell  
Stone, crushed  
Cobbles, beach, river  
Pebbles, beach, river  
Mine dump waste rock  
Slag  
Pumice rock  
Lava  
Glass cullett, marbles  
Cinder  
Medium particles  
Decomposed granite  
Coarse sand  
Mine-mill screenings  
Smelter slag screenings  
Pumice  
Glass beads, shot  
Asbestos  
Roofing granules, slate  
Roofing granules, synthetic  
High aspect ratio mica  
Adebe  
Fine particles  
Beach sand  
Diatomaceous earth  
Rock dust  
Cement mill waste fines  
Ground limestone  
Portland cement  
Gypsum  
Clay  
Talc  
Asbestos floats  
Bag house dust (air filter)  
Ground Glass fines  
Glass spheres or balls  
Glass microballoons  
Mica

**CRISIS IN CARBON CHEMISTRY**

Considerable attention has been given in recent months to the crisis of feedstocks plaguing the industries based upon carbon chemistry, and that includes electrical energy, natural gas for heating and resins, petroleum fuels, for transportation, inter-

mediates for polymers, plastics, rubbers, fibers, soaps, pharmaceuticals, and on and on. Obviously, as the Shah of Iran said in January 1974, we must stop burning fossil fuels and save them for their petrochemical feedstock content, which is vital to the carbon chemistry dependence of our modern civilization.

Alternatives have been covered by many writers. Carbon compounds can be derived from living plant and animal tissue, and can be synthesized from carbon found in rocks and the atmosphere. Energy demands can be met by means not involving burning of fossil fuels. Such energy sources are nuclear fusion and fission, solar power, wind power, tide action power, hydroelectric stream power, geothermal steam power, ocean thermal gradient power, etc. Fossil fuel reserves of the United States, North America, and the earth have been partially developed, and vast reserves of the more expensive deposits, such as shale oil, tar sands and coal await exploitation. But if alternate energy sources are speedily developed, fossil fuels can be saved to protect the carbon chemistry feedstock needs of an expanding world petrochemicals industry.

#### THE NEED FOR ALTERNATE POLYMER CHEMISTRY

When John Wesley Hyatt made celluloid from gun-cotton and Dr. Baekeland developed phenolics from benzene and formaldehyde, the plastics industry launched a tremendous surge into polymers based on feedstocks of carbon chemistry. Some 204 billion pounds and a hundred years later, we find our supply of carbon chemistry feedstocks in short supply and prices rising sharply.

Little attention has been paid by the plastics, rubber, and fiber industries to alternate feedstocks, polymers and means of supplying the needs of society. But the similar chemical behavior of silicon and boron in polymer formation has been known for many years. Valence is similar, compound formation parallel but more difficult. Most important is the greater abundance of raw materials for silicon polymer and fiber chemistry (8). While carbon comprises only 0.027% of the earth crust and atmosphere, silicon is 25.7% and oxygen 49.2%. Boron is not as abundant as carbon, but has less competition for its use, and is abundant in California deposits. Ironically, the present polymer industry is tied almost exclusively to the chemistry of carbon, one of the rare elements on earth.

In our discussion of fillers for resins and structures, silicates will be common, very abundant minerals. Aluminum is 7.4% and iron 4.7% of the earth's crust, and their oxides or silicates are good fillers, as well as their metal particles.

#### HIGHLY FILLED RESINS IN TOOLING

Fillers have long been added to resins for functional purposes, to reduce reaction temperature, shrinkage or cost. Cellulosic fillers have predominated in urea, melamine and phenol formaldehyde high-pressure molding powders. Glass fiber, asbestos and mineral powder fillers are used in BMC and SMC. Tooling epoxy resins incorporate light filling of aluminum powder. Automobile body putties are polyester with paste loadings of mineral powder and fumed silica thixotropic powder. Cultured marble is polyester heavily filled with CaCO<sub>3</sub> fines, cast and vibrated into molds behind colored gel coats.

Theory of very highly filled plastics involves some important considerations. Oil absorption of some fillers is high, rapidly increasing viscosity, limiting flow and loading. Some fillers, such as spherical (baller) glass beads, have low oil absorption, and excellent flow. Flake or jagged particles may mix and flow poorly. Curled metal chips do not pack densely. Fillers have a wide variety of particle shapes and sizes. Most studies have been made on spherical particles, because mathematical calculations are easier for solid particle to void space ratio, or packing.

An adequate adhesive bond line without excess resin is necessary between adjacent filler particles. Bond to particle surface must be strong, involving filler clean of substances which might inhibit or release the resin adhesion. The science of maximum packing of solid particles, and of proper sizing and shapes of solid particles in the composite, is vital.

Some fillers may affect curing rate of reactive resins, or flow rheology of thermoplastics. Physical or chemical properties of the finished composite will be a function of the various fillers and aggregates incorporated.

The extent to which a given volume of liquid casting resin may be "stretched" by adding fillers and aggregates in a casting depends upon success in achieving maximum solid volumetric content, minimum resin volume content. Studies published in metallurgical, mining, ceramic and nuclear fuels journals, indicates 4.2% volume void space is theoretically possible in a 5 to 7 size particle system, with vibration packing. In resin castings with various solid particles of solid waste type, 50 to 75 % solid filler packing by volume is achievable, and higher packing is possible using special considerations and an assortment of sizes and shapes from fine to large. Diameters of spherical fillers should increase seven-fold between sizes for maximum packing. Vibration and

mechanical tamping may help.

Several species of fillers may be incorporated in a given composite, including several metal types, mineral powders or rock aggregates, wires, rods, etc. Provisions for heating and cooling may be cast into composite tools, as in cast epoxy resin tooling.

ICMA, Milan, Italy, has developed a process for adding wood-filler to plastic at 60% density. The plastic resin is PP or PE. Bolton-Emerson, Inc., Lawrence, Massachusetts, now offers a complete line of sheet equipment for \$130,000. Applications include filler panels to provide stiffening in construction and transportation, and moderately load-bearing uses in auto dash boards, furniture, doors, acoustics, conduit, drawers, and interior moldings.

#### CONCLUSION

With resins scarce and expensive, all the conventional mineral and cellulosic fillers are being added to stretch out resin supply.

Additional emphasis is being put on unusual fillers, such as biodegradables, metallics, and solid wastes.

Thermoplastic and thermoset composites are being reemphasized using a conglomeration of fillers.

#### BIBLIOGRAPHY

1. "Plastic Tooling," William P. BENJAMIN, 1973, McGraw-Hill Book Company, New York and London.
2. "Alcan Metal Powders," brochure, Alcan Metal Powders Division, Alcan Aluminum Corporation, Elizabeth, New Jersey.
3. "Integrally Heated Tools For Compression Molding," Blaise LEWARK, 1973, 7th Annual Western Plastics For Tooling Conference, SPI, pp. 6-10.
4. "Mechanical Packing of Spherical Particles," R.K. MC GEARY, Journal of the American Ceramic Society, 44 (10) 513-521, (1961)
5. "Density and Packing in an Aggregate of Mixed Spheres," D.R. HUDSON, Journal of Applied Physics, 20, 154-162 (1949).
6. "A Study of the Packing of Milled Fiberglass and Glass Beads," John V. MILEWSKI, 1973, 28th Annual Conference, Reinforced Plastics/Composites Institute, SPI.
7. "The Versatile World of Conglomerate/Composites," Part I, Edwin F. BUSHMAN, and Bruce E. BUSHMAN, 1973, 31st Annual Conference, Society of Plastics Industry of Canada.
8. "A Strategic Resource Study of the

Fiber, Reinforcement, Resin, and Elastomeric Industries: Shortages, Feedstocks, Product, Strengths, Vulnerabilities," Edwin F. BUSHMAN, 1974, 29th Annual Conference, Reinforced Plastics/Composites Institute, SPI.

9. "Polymer Tooling for 200-500° F Service, Materials Selection and Fabrication Techniques," Paul R. CAREY, 1969, 11th Annual Seminar on Plastics For Tooling, SPI and Purdue University, Eng. Bulletin #134, Engineering Extension, Purdue University, West Lafayette, Indiana.
10. "Handbook of Chemistry and Physics," Chemical Rubber Publishing Company, Cleveland, Ohio.
11. "Resin Stretching: Accent on Performance," Modern Plastics, (January 1974, page 50 ff.)
12. "Reclaimed Waste: It's Like 250,000 Tons of New Resin Capacity," Modern Plastics (February 1974, page 38 ff.)
13. "Process Engineering," Plastics Technology (January 1974, page 14).
14. "Starch Makes Plastics Biodegradable," G. GRIFFIN, Polymer Symposium (Chicago), August 1973, American Chemical Society.
15. "Major Breakthrough in Low Cost Plastic Housing Using Jute Reinforced Polyesters," A.G. WINFIELD, B.L. WINFIELD, 29th Annual Technical Conference, 1974 RP/C Institute of SPI, Section 7-A, pages 1-11.
16. "Polyester Resins Reinforced with Har Mica", R.T. WOODHAMS, M. XANTHOS, 29th Annual Technical Conference, 1974 RP/C Institute of SPI, Section 4-E, pages 1-6.
17. "Cultured Marble," R.B. BROPHY, Gruber Industries, 1968.

## BIOGRAPHIES

Edwin F. Bushman has worked with petroleum, polymers, mineral and organic fillers since college days at the University of Illinois, California Institute of Technology, and Scripps Institute of Oceanography prior to WWII. He researched methods and equipment for underwater casting and photography and large molds for relief maps during WWII. His first polymer metal-composite mold was made in 1945-46. He has been active in plastics engineering and consulting on all polymer methods and practices. He has served Bell and Howell Company, Gulf Oil Corporation, General American Transportation Corporation, USS Chemicals Division of US Steel Company, Sierra Engineering Company, A & E Plastics, and others. A native of Illinois, he lives with his large family at 19 Lagunita, Laguna Beach, California.

Bruce E. Bushman was born 8 April 1947 in Aurora, Illinois. He was educated at Mater Dei High School in Santa Ana, California; at Seattle University (B.S., physics, magna cum laude); at the University of Illinois; and at California State University at San Diego.

TABLE I  
TYPES OF COMMON METAL PARTICLES AND SCRAP AGGREGATE

Type of Metal Aggregates	Mg	Al	Bronze-Brass	Copper	Fe-Steel	Pb	Ni	Zn or Kirk-site
Spherical Shot		X		X	X	X		
"Ingot"		X						
Nodules		X						
Needles		X						
Pellets		X		X				
Chopped Wire		X		X	X			
Chopped Rods	X	X			X			
Punch Press Sheet Slugs		X			X			
Punch Press Plate Slugs	X	X			X			
Powders	X*	X	X	X	X	X	X	X
Dust		X	X		X			
Blanchard Grinder Filings		X	X		X			X
Saw Filings		X	X	X	X			X
Machining Chips		X	X	X	X			X
Reinforcing Rod Scraps					X			
Scrap Railroad Spikes					X			
Waste Nuts, Bolts			X	X	X			
Old Nails					X			
Shot Blast Waste					X			
Old Welding Rods			X		X			
Obsolete Rivets					X			
Bag House Fines (Air Filter)			X	X	X			X
Automobile Brake Drum Filing					X			

\* Explosion or flame hazard

TABLE III

VARIOUS ALLOYS	DENSITY		
	S.G. gms./cc	Lbs./cu.ft.	Lbs./cu.in.
<b>ALUMINUM/COPPER</b>			
10 AL, 90 Cu	7.69	480.06	0.277
5 AL, 95 Cu	8.37	522.51	0.302
3 AL, 97 Cu	8.69	542.49	0.313
<b>ALUMINUM/ZINC</b>			
91 AL, 9 Zn	2.80	174.80	0.101
<b>BELL METAL</b>			
78 Cu, 22 Zn	8.70	543.11	0.314
<b>BISMUTH/LEAD/TIN</b>			
53 Bi, 40 Pb, 7 Sn	10.56	659.23	0.381
<b>BRASS</b>			
YELLOW: 70 Cu, 30 Zn, cast	8.44	526.88	0.305
" " " " " rolled	8.56	534.38	0.308
" " " " " drawn	8.70	543.11	0.314
RED, GUN METAL: 90 Cu, 10 Sn	8.78	548.11	0.316
85 Cu, 15 Sn	8.89	554.98	0.321
80 Cu, 20 Sn	8.74	545.61	0.316
75 Cu, 25 Sn	8.83	551.23	0.318
<b>GERMAN SILVER</b>			
26.3 Cu, 36.6 Zn, 36.8 Ni	8.30	518.14	0.300
63 Cu, 30 Zn, 6 Ni	8.30	518.14	0.300
<b>LEAD AND TIN</b>			
87.5 Pb, 12.5 Sn	10.60	661.73	0.382
63.7 Pb, 36.3 Sn	9.43	588.69	0.340
20.5 Pb, 69.5 Sn	8.24	514.40	0.296
<b>MANGANESE BRONZE</b>			
95 Cu, 5 Mn	8.80	549.36	0.317
<b>MONEL METAL</b>			
71 Ni, 27 Cu, 2 Fe	8.90	555.60	0.321
<b>PHOSPHOR BRONZE</b>			
79.7 Cu, 10 Sn, 9.5 Sb, 0.8 P	8.80	549.36	0.317
<b>STEEL</b>			
99 Fe, 1 C	7.83	488.80	0.282
86 Fe, 13 Mn, 1 C (Manganese)	7.81	487.55	0.282
<b>WOODS METAL</b>			
50 Bi, 25 Pb, 12.5 Cd, 12.5 Sn	10.56	659.23	0.381

DATA SOURCE: Handbook of Chemistry and Physics

TABLE IV

VARIOUS SOLIDS (@ 70°F)	S.G. Gm./cc	Lbs./ cu.ft.	Lbs./cu.in.
AGATE (CHALCEDONY)	2.5-2.7	156-168	0.0903-0.0972
ANORTHITE	2.74-2.76	171-172	0.0987-0.0990
ASBESTOS	2.0-2.8	125-175	0.0725-0.101
ASBESTOS SLATE	1.8	112	0.0650
BARITE, BARYTES	4.3-4.6	268-286	0.156-0.166
BASALT	2.4-3.1	150-190	0.0870-0.110
BAUXITE	2.55	159	0.0920
BIOTITE (BLK, MICA)	2.69	168	0.0970
CALSPAR, CALCITE	2.6-2.8	162-175	0.0940-0.101
CEMENT, SET	2.7-3.0	170-190	0.0985-0.110
CHALCEDONY, FLINT	2.55-2.63	159-164	0.0922-0.0950
CHALK	1.9-2.8	118-175	0.0684-0.101
CLAY	1.8-2.6	112-162	0.0650-0.940
COAL, BITUMINOUS	1.2-1.5	75-94	0.00434-0.00545
CORUNDUM	3.9-4.0	245-250	0.143-0.145
DOLomite	2.84	177	0.1025
EMERY	4.0	250	0.145
EPIDOTE	3.25-3.50	203-218	0.117-0.126
FELDSPAR	2.55-2.75	159-172	0.0920-0.0996
FLINT	2.63	164	0.0950
FLOURITE	3.18	198	0.115
GALENA	7.3-7.6	460-470	0.264-0.272
GARNET	3.15-4.3	197-268	0.114-0.155
GLASS, COMMON	2.4-2.8	150-175	0.0870-0.101
GRANITE	2.64-2.76	165-172	0.0955-0.0996
GRAPHITE	2.30-2.72	144-170	0.0334-0.0984
GYPSUM	2.31-2.33	144-145	0.0834-0.0840
HEMATITE	4.9-5.3	306-330	0.177-0.192
HORNBLende	3.0	187	0.108
LIMESTONE	2.68-2.76	167-171	0.0967-0.0987
LIMONITE	3.6-4.0	225-249	0.130-0.145
MAGNESITE	2.95-3.2	184-199	0.106-0.116
MAGNETITE	4.9-5.2	306-324	0.177-0.187
MALACHITE	3.7-4.1	231-256	0.134-0.148
MANGANITE	4.2-4.4	262-274	0.152-0.159
MARBLE	2.6-2.84	160-177	0.0927-0.1025
MICA	2.6-3.2	165-200	0.0960-0.116
MUSCOVITE	2.76-3.00	172-187	0.100-0.108
OPAL	2.2	137	0.0793
PORCELAIN	2.3-2.5	143-156	0.0828-0.0903
PORPHYRY	2.6-2.9	162-181	0.0938-0.105
PYRITE	4.95-5.1	309-318	0.179-0.184
PYROPHYLLITE	2.66-2.90	166-181	0.0963-0.105
QUARTZ	2.65	165	0.0960
RUTILE	4.18-5.13	261-321	0.152-0.186
SANDSTONE	2.14-2.36	134-147	0.0777-0.0852
SERPENTINE	2.50-2.65	156-165	0.0904-0.0960
SLAG--IRON-COPPER	2.0-3.9	125-244	0.0721-0.141
SLATE	2.6-3.3	162-205	0.0938-0.118
SOAPSTONE	2.6-2.8	162-175	0.0938-0.101
TALC	2.7-2.8	168-174	0.0974-0.101

Data Source: Handbook of Chemistry and Physics

Table Va

Ambient Coefficient of Thermal Conductivity (K Factor)

	<u>Btu/hr/ft<sup>2</sup>/°F/in</u>
Silver	2900
Copper	2690
Aluminum	1390
Cast Aluminum	950
Alloy Steel	312
Cast Stainless Steel	156
30 Mesh Copper Pellets	4.44
30 Mesh Aluminum Pellets	4.00
Cast Epoxy Unfilled	1.60
Cast Polyester	1.30
Silicone Rubber	1.30
Epoxy Laminate (40% Glass)	0.97
Wood (Silver Maple)	0.95
40 pcf Urethane Foam	0.36
Silicone Foam	0.30
Fiberglass Cloth	0.26
Air	0.17
2pcf Urethane Foam	0.13
55% Aluminum Needles + Epoxy	66
24% Aluminum Needles + Epoxy	20.1
77% 30-40 Mesh Aluminum Pellets + Epoxy	19.4
91% + 325 Mesh Copper Powder + Epoxy	11.3
Epoxy Powder Coated Aluminum Pellets	11.1
70% Alcoa 123 Aluminum Powder + Epoxy	10.2
73% + 325 Aluminum Powder + Epoxy	9.9
Expanded Aluminum Metal + Fiberglass + Epoxy Laminate	8.7
72% + 325 Iron Powder + Epoxy	6.2
56% + 325 Silica Powder + Epoxy	5.4
Cast Epoxy (Unfilled)	1.6
15% Phenolic Microballoons + Epoxy	1.4
40% Fiberglass + Iron Filled Epoxy Laminate	0.9

Data Source: Paul Carey (7)

Table Vb

Specific Heat of Hi-Temp Tooling Materials (Btu/lb./°F)

Silver	0.056
Copper	0.10
Aluminum	0.23
Polyesters and PVA Film	0.28
Polyester Casting (Unfilled)	0.30-0.56
Silicone	0.32
Epoxy Laminate (40% Glass)	0.39
Hi-Temp Epoxy Resin	0.20-0.30

Data Source: Paul Carey (9)

Table Vc - Specific Gravity and Specific Heat of Common Solid Substances

Solid	Specific gravity	Specific heat, Btu/lb-°F	Solid	Specific gravity	Specific heat, Btu/lb-°F
Asbestos	2.0-2.8	0.195 at 68-212 F	Graphite	...	0.3-.38 at 70-2200 F
Ashes, cinder	.64-.72	.2 at 32-212	Gypsum	2.31	.259 at 50-212
Asphalt	.99-1.43	.55	Hay & straw	.32	....
Asphaltum	.87-1.51	.22	Ice	.92 at 32 F	.492 at 32
Beeswax	.96	.82 at 60-144	Kaolin	2.40-2.60 (bulk)	.22 at 68-212
Borax	1.70	.238 at 51-208	Leather, dry	.87	.36
Brick, soft	1.70-1.89		greased	1.03	....
common	1.79-2.0		Lime	.85-1.20 (bulk)	....
fire	1.70-2.10	.2-.25 at 64-212	Limestone	2.28-2.74	.217
hard	1.89-2.10		Linoleum	1.20	....
vitrified	2.0-2.2		Magnesite, refractory	2.90-3.09	.27 at 60-1200
Calcium carbonate	2.71-2.97	.21 at 32-212	Marble	2.69-2.90	.21 at 32-212
Camphor	.99	.44 at 68-353	Naphthalene	1.49	.325 at 68-140
Caoutchouc	.91-.99	....	Paper	.71-1.15	.349
Celluloid	1.35-1.39	....	Paraffin	.87-.95	.7 at 32-68
Cellulose	1.51	.32 at 32-212	Pitch, coal tar	1.07-1.15	.45 at 60-212
Celotex	.21-.26	.4	Plaster of Paris, set	2.31	1.14
Cement, loose	1.15-1.68 (bulk)	.20 at 68-212	Plastics		
set	2.69-3.0	.20 at 68-212	acrylonitrile	1.06	.35
Cereals	.42-.77	....	butyrate	1.2	.35
Charcoal, pine	.37	.17	polyethylene	.92-1.0	.55
oak	.53	....	polyvinyl chloride	1.38	.2
Clay, dry	1.01	.22 at 68-212	Porcelain	2.29-2.50	.26 at 60-1750
damp	1.76	....	Potassium nitrate	2.08	.19 at 59-212
Coal, anthracite	.83-.93 (bulk)	.26-.37	Potatoes	.71	.84
bituminous	.71-.87 (bulk)	....	Resin, phenol	1.25	.33-.37 at 167-212
lignite	1.25	....	Riprap, limestone	1.28-1.36	....
peat, dry	.75	....	sandstone	1.44	....
Coke	.37-.51 (bulk)	.24 at 68-500	shale	1.68	....
Concrete	2.22-2.50	.18-.19 at 72-372	Rubber, India	.91-.93	.48 at 32-212
Cork board	.16	about .49	hard	1.20	.33-.40 at 32-212
Cotton	1.49	....	Salt, rock	2.15	.219 at 55-113
Dolomite	2.76-2.95	.22	Sand, dry	1.44-1.92 (bulk)	.195 at 32-212
Dry ice	1.51-1.67	.204 at 75-135	Sandstone	2.16-2.64	.22
Earth, dry	1.04-1.41	.0014 at 68	Shale	1.44-2.72	....
moist	1.30-1.60	.0052 at 68	Shellac	1.20-1.22	.40 at 60-212
mud	1.28-2.08	.0067 at 68	Silicone carbide	....	.23 at 60-950
Emery	3.75-4.34	....	Slag	2.76	....
Fat, beef	.91-.98	.52 at 43-79	Sodium carbonate	2.44	.306
		.79 at 79-108	Sodium nitrate	2.24	.231
		.54 at 151-216	Starch	1.54	....
Flour	.45-.75	....	Stone	....	about .2
Glass, crown	2.29-2.90	.16 at 50-122	Sugar, cane	1.63	.30 at 68
flint	2.90-5.90	.12 at 50-122	Tar, coal	.95-1.33	.35-.45 at 68-392 F
jena	2.37-2.58	.20 at 66-212	Tile	1.79-1.89	.150
pyrex	2.24	.196 at 68-212	Wool	1.30	0.325
Granite	2.60-2.72	0.19 at 54-212 F			

REPRODUCIBILITY OF THE ORIGINAL PAGE IS POOR

Table VI

Coefficient of Linear Expansion of Hi-Temp Tooling Materials

<u>Material</u>	<u>Coefficient</u> <u>(10<sup>-6</sup> in/in/°F)</u>
Polyester (Cast)	56-28
Epoxy (Cast)	50-18
12.7 phr Glass Microballoons--Epoxy	44
13.6 phr Phenolic Microballoons--Epoxy	44
70 Weight % Aluminum Filled Epoxy	31
Epoxy (Filled Heat Resistant Casting)	30-18
Low Pressure Polyester Glass Laminate	30-12
Low Pressure Epoxy Glass Laminate	20-11
High Pressure Glass Laminate	17-5.5
Aluminum	13
Hi-Temp Epoxy Fiberglass Laminate	11
Stainless Steel (Cast)	10.4-6.4
Alloy Steel (Cast)	8.3-8.0
Malleable Iron	7.5-5.9
Grey Iron (Cast)	6.0
Fiberglass	2.3

Data Source: Paul Carey (9)

**TABLE VII**

Conversion Tables--Metric to U.S. Std.

Volume

1 Liter @ 4°C and 760 mm pressure (= 1 kg water)  
1 U.S. gallon = 0.83267 Imperial Gallon

Metric				U.S. Std.				
Liter	ml-liter	cu. cm.	cu. meter	bushels	gal.	fl. oz.	cu. in.	cu. ft.
1	1,000.	1,000.027	.001000027	.0283782	0.264178	33.8147	61.0250	0.03531
		1,000,000	1.					35.3144
					7.481		1728	1.
		16.3872					1.	.000578704
3.785		3,785			1.			0.1336+

Length

1 micron =  $10^{-4}$  cm  
 =  $3.93700 \times 10^{-5}$  in. (U.S.)  
 =  $10^4$  Angstroms  
 1 centimeter = .01 meter  
 = 0.393700 in. (U.S.)  
 = 3.28083 feet (U.S.)  
 = 39.3700 in. (U.S.)  
 = 1.09361 yards (U.S.)  
 1 mm = 0.0393700 in. (U.S.)

Area

1  $\text{cm}^2$  = 0.15500 sq. in. (U.S.)  
 1  $\text{meter}^2$  = 10.76387 sq. ft. (U.S.)  
 1 sq.ft.(U.S.) = 144 sq. in. (U.S.)  
 = 0.09290341 sq. meter  
 1 in.<sup>2</sup> (U.S.) = 6.451626 sq. cm.  
 = .0069444 sq. ft. (U.S.)

Conversion Table--Metric to U.S. Avoirdupois

Weight

milligram	gram	kilogram	ounce	pound	short ton	metric ton
	453.5924277	0.4535924	16	1.	$5 \times 10^{-4}$	
1,000,000.	1,000	1.	32.150742	2.2046223	0.0011023112	0.001
1,000.	1.	.001	0.0352739			
		907.18486	32,000	2,000	1.	0.907185
		1,000.		2,204.6		1.

Pressure

1 pound per sq. in. (U.S.) =  $0.07031 \text{ kgm/cm}^2$  =  $70.31 \text{ gm/cm}^2$   
 =  $703.1 \text{ kgm/meter}^2$

Energy

calory	kilo-calory	watt-hour	kilowatt-hour	foot-pound	B.T.U.	Joule
252.0	0.2520	0.2928	$2.928 \times 10^{-4}$	777.5	1	
$8.605 \times 10^5$	860.5	0.001	1	$2.655 \times 10^6$	3415	
$3.241 \times 10^{-7}$	$3.241 \times 10^{-4}$	$3.766 \times 10^{-4}$	$3.766 \times 10^{-7}$	1	$1.286 \times 10^{-3}$	1.356
$2.39 \times 10^{-7}$	$2.39 \times 10^{-4}$	$2.778 \times 10^{-4}$	0.2778	0.7376	$9.486 \times 10^{-4}$	1

1 h.p. = 42.44 BTU/min. = 2544.5 PTU/hr.  
 = 745.7 Watts = 0.7457 kilowatts  
 = 33,000 Ft.-Lb/min.

Data Source: Handbook of Chemistry and Physics

ADVANCED TOOLING TECHNIQUES USING  
A THERMOPLASTIC COMPOUND

Arthur R. Gomez  
Douglas Aircraft Company  
Long Beach, California

Abstract

This paper is a compendium of a variety of manufacturing applications and the material evaluations performed on the thermoplastic tooling compound known as "Rigidax." It attempts to relieve the high cost of tooling for small, odd-shaped, low-volume parts and considers the problems in supporting thin flexible parts during machining.

1. INTRODUCTION

The aerospace industry has always the problems of providing support tooling and fixtures for small, odd-shaped, thin-walled aircraft parts. The large number of such parts constitutes an expense in the tool design, tool fabrication and tool storage. Costs are high for removing these tools from storage and reworking them to the latest changes, especially for a low-volume production run.

For these reasons, the conventional metal working support tooling concepts were set aside and a literature search was made in the thermoplastic compounds field. The number of available materials or compounds for such applications as potting or encapsulation material was small.

The most effective was polyethylene glycol which is utilized for a particular application in honeycomb-bonded panels.

The operations involved in heating thermoplastic materials, pouring, and reheating, or melting off, are not normal functions of the machine shop. Operators resist using thermoplastic materials and must have impressive evidence of operating benefits before they will accept its use. Such a material must be easily meltable, reduce scrap rate, provide ease of indexing and not be detrimental to machine or cutting tools.

A reusable, thermoplastic material possessing such characteristics is Rigidax, first introduced to this machining study in 1969, and studies were conducted over a 2-year period, under Douglas Independent Research and Development.

A complete material analysis of this tooling compound was made to determine maximum compressive strength, shrinkage, possi-

bilities of residual contaminant, and a physical study of the milling cutter dampening features of this material.

Application techniques such as encapsulating, brush coating, etc., were studied before subjecting the tooling material to a cost comparison with a polyethylene glycol, epoxy resin and "Cerrobend" materials.

A wide variety of odd-shaped metal parts of different materials were cast in Rigidax and successfully supported during machining. Some of the types of parts which merit encapsulating in Rigidax for machining are:

- Small parts not easily secured to a machine table
- Irregularly shaped parts for which setup and orientation are difficult and time consuming
- Flexible parts or parts with thin members, which are incapable of supporting themselves with sufficient rigidity during machining
- Temporary hydropress forming dies
- Development tooling for the construction of new aircraft ducting paths.

The use of Rigidax to support large quantities of lightweight latch pin parts during machining reduced the scrap rate of these parts approximately 40 percent.

The cost of resurrecting old tooling for a single rework was avoided by substituting a thermoplastic compound base during machining. Other temporary tooling was provided in the same manner which allowed continued machining of a tightly scheduled large DC-10 landing gear fitting.

Cutter tool chatter was minimized in the machining of light-weight thin-walled detonator seat support by adding a recast operation of backup material for continued machining operations. This castable material was used to remove a contour pattern from the surface of master plaster tool, and then became the forming die for two prototype aluminum material AQ condition pieces on a hydropress forming operation.

The necessary support equipment to provide a small machine shop with a fast, low-cost tool-up capability includes a melt pot unit, a set of infrared lamps for preheat and remelt, and a supply of thermoplastic material.

A cost comparison study of the tool-compound held method versus conventional techniques was made, which showed a cost avoidance of approximately \$15,682, programmed over a 9-month period. This figure is based on decreased machine setup, machine run time, lower rejections and eliminated scrap rates.

## 2. DISCUSSION

### 2.1 MATERIAL

The aerospace industry's demands for more strength from thin members, particularly from those of exotic materials, have introduced substantial machining problems. Rigidax was introduced to alleviate the problems of machining high-strength, heat-resistant alloys which are extremely susceptible to contamination. The McDonnell Douglas Astronautics Company -- Western Division, at Huntington Beach, used Rigidax in the machining of several parts for the Manned Orbiting Laboratory (MOL) program. Douglas began an investigation of the material at Long Beach to determine handling characteristics and to develop application methods to enhance shop procedures.

Rigidax is available commercially in four grades:

- (1) Type WS (water soluble) Color: Off-white
- (2) Type WI (water insoluble) Color: Metallic gray
- (3) Type WI-NMF (water soluble -- nonmetallic) Color: Red
- (4) Type WI (water insoluble) Color: Green

The green water-insoluble type was selected for this program because of its better physical properties and its ability to maintain straight machining reference surfaces.

Before any attempts were made to use this material, several bench tests were performed to determine its handling characteristics in both the molten and solid states. For testing purposes, a thickness of 1/2 inch was selected for encapsulating components less than 12 inches in height. Because of the possibility that holding failure might occur during machining, safety personnel requested verification and support data from the supplier and received the following specifications:

Compressive Strength	3500 psi
Tensile Strength	1400 psi

Impact	37 ft/lb
Density	0.066 lb/cu in.
Specific Volume	15 cu in./lb

Further studies considered storage of the material indoors as well as outdoors, and the flow or casting features of the material in its molten state. Also considered were the times required to melt varying thicknesses of material, and for the material to harden.

Outdoor experiments, exceeding 1000 hours exposure at temperatures between 50° and 95°F, were conducted on a 1-inch-thick, 4 by 6-inch block of Rigidax. A thermometer embedded at the center of the specimen showed that the material accumulated heat and, reaching a maximum internal temperature of 120°F, softened to the extent that it could be moved with finger pressure. This factor precludes the use of this material as a permanent tool since outdoor storage would be required. No other damage to the material was observed.

Results of studies on flow and casting characteristics indicated that the molten material poured with the consistency of light molasses. It was also observed that secondary interlocking material layers provided for correction of errors in encapsulation. Also, in cases where a material leak occurred between the supports during pouring, the material outflow was quickly stopped by pouring tap water over the flow.

Machining metal chips are picked up and suspended in molten Rigidax, and resist efforts to remove them. While not affecting the melting or hardening times appreciably, more material should be added when large quantities or excessively large chips are accumulated. Thus, addition of new material will reduce the chip content sufficiently.

A mold release spray (DPM 3494) should be used to prevent the encapsulation from adhering to the surface table after part preparation.

When removing Rigidax from the part, the bulk of the material is usually broken away with a hammer. It is often removed, at least in part, by being melted with an infrared lamp. As a result of various melt-down tests, an average rate of 10 minutes per pound was established, using four 750-watt infrared lamps set to a height of 11 inches. Rigidax blocks melt at essentially the same rate as material cast around parts.

Due to its heat-retention characteristics, tests were run to determine the hardening times of various thicknesses of Rigidax. Blocks 3 by 8 inches, and 1, 1-1/2, and 2 inches thick, were subjected to 300- and 500-in./lb loads over a 1-inch-square area for 15 seconds. All specimens were allowed to cool at room temperature. These tests showed that Rigidax requires 4 to 6 hours to reach full hardness. This amount of cool-down time is too long for production purposes and clamping on soft Rigidax can move the workpiece causing loss of machining reference planes.

In attempts to reduce the 4- to 6-hour requirement, several specimens were allowed to cool at ambient temperature for 30 minutes, then dipped in cold water (40°F) for 90 minutes. The Rigidax achieved full hardness, affording a 2- to 4-hour reduction in cool-down time.

Machinability tests showed excellent stability. Using both the room-cooled and water-cooled samples, an end-mill cutter was used at maximum feed to cut smooth surfaces at various cutting speeds and depths.

## 2.2 CHEMICAL ANALYSIS

Studies were conducted to examine the possible adverse effects of this material on the surfaces of steel, magnesium, and aluminum parts. A total of 4 steel, 10 aluminum, and 2 magnesium panels were coated with Rigidax Type WI-green and, after removal of the compound, were subjected to the following appropriate processes:

- Aluminum panels anodized per DPS 11.01
- Steel panels cadmium plated per DPS 9.28
- Steel panels nickel plated per DPS 9.76-1
- Magnesium panels conversion coated per DPS 9.41
- Sandwich corrosion tests on aluminum conducted per DLP 13.704

Additional composition studies were conducted using infrared and X-ray fluorescence analyses. Results indicate that after the tooling compound is removed from the part, vapor degreasing is mandatory.

Used in accordance with vendor instructions, Rigidax shows no significant detrimental effects to the metal surfaces and to subsequent chemical operations. Further chemical information on this material may be found in Laboratory Report DAC-4927, "The Effects of Rigidax Compound Type WI-Green on Magnesium, Steel, and Aluminum Alloys," dated January 21, 1970.

## 2.3 MACHINE SHOP TESTING

Machine shop experiments were developed to evaluate the applicability of Rigidax in the machine shop, and its long-term handling characteristics and limitations. A variety of odd-shaped parts of several materials were selected to permit a broad-based study of methods for holding or enclosing parts during machining. Steel banding strips were used as a dam to enclose the parts. Another tooling material, Babbitt Rite, was found to be very useful for securing the ends of the steel banding, and for sealing the area to be poured. Some of the parts which particularly lend themselves to encapsulation in Rigidax for machining are:

- (1) Small parts not easily secured to the machine table, or where the attaching hardware would interfere with machining
- (2) Irregularly shaped parts for which setup and orientation are difficult and time consuming
- (3) Flexible parts, or parts with thin members, which are

incapable of supporting themselves with sufficient rigidity during machining

- (4) Parts which could be damaged by being secured to the machine table.

In the past, machining operations on difficult-to-hold parts have involved time-consuming setups and have resulted in a high scrap rate. Now, using Rigidax, several production parts of this type have been successfully reworked without schedule impact. Conventional methods of holding such parts for rework could have easily resulted in scrapping the items.

Before starting machine shop tests, several guidelines were established for the use of Rigidax. First, the encapsulation or potting of a production piece must take into consideration the shape, size and quantity of the parts. Such consideration reduces the extra steps which could be required. Second, the part must be set up over a surface table and encapsulated with one or two surfaces as references. These Rigidax reference surfaces align the workpiece to the machine. Techniques used to lock parts in Rigidax include the following:

- (1) Installation of a material support as the base for a flexible part
- (2) Brush application of small portions of Rigidax for localized support
- (3) Use of steel pads beneath the material support of a nonmagnetic part to enable the assembly to be held securely on the magnetic chucks of the machine.

In several experiments, this tooling compound was used as the intermediate holding material between the bed of the machine and the part. In these applications, the part was encapsulated, and the Rigidax was keyed to clamping angles.

Large quantities of small, odd-shaped parts lend themselves readily to Rigidax holding techniques. For instance, the application of Rigidax to one side of an odd-shaped part permits the part to be held in a conventional vise. This combination of conventional equipment and castable material is demonstrated on snug-fit tools. A snug-fit tool is cast on both sides of the part with the parting plane at the center. The periphery of the cast material can be fitted to the conventional equipment which holds the assembly on the machine. Conversely, clamping angles, T-bolts, and blocks which interlock the ways of the machine bed can be preset and cast in place, thereby aligning and referencing the part to the machine.

In tests performed to study the holding capacity of this material on laminated panels, a 0.040-inch-thick boron composite panel was sandwiched between 0.125-inch-thick layers of Rigidax. The Rigidax supported the panel adequately during drilling of 1-inch-diameter holes, without excessive delamination.

Small, more or less symmetrical parts lend themselves to interesting applications, including multiple-machining methods.

In one case, 36 lightweight aluminum latch pins were encased in groups of 12. A straddle mill was used to cut four separate surfaces during each pass of the cutter.

The previous method, machining each piece individually, was time consuming and rejections exceeded 50 percent.

A partially assembled instrument panel provided a problem especially suited to Rigidax. While this part was held securely in the tooling compound, a portion of the upper surface of the panel was machined to permit installation of an 0.190-inch plate. Due to its partially assembled state, normal orientation planes were not usable, so the panel was cast in Rigidax to permit setup in the machine. The affected surface was removed by an end mill cutter and the part was delivered on schedule. Other methods could not be expected to affect this particular rework due to the flexibility of the panel.

Large parts are not excluded from this casting procedure as is demonstrated by the encapsulation of two 8- by 10- by 28-inch base pads for a 700-pound landing gear forging. Several important factors were identified, including:

- The cooling rate of the material is slow enough to allow each succeeding layer to interlock with the preceding layer.
- Pouring of 225 pounds of material can be accomplished in less than 5 hours by using a 20-minute cycle to reload and melt each 75-pound batch of the tooling compound.
- When large quantities of Rigidax are used, it is difficult to determine when the material has completely hardened.

Small tool-steel parts tend to warp in heat treat after machining in the standard vise-held setup. The same parts, held in Rigidax, show no such tendency. Tests performed on tooling blades held in Rigidax during machining show that this procedure can be used for grinding, end-mill cutting and lapping operations.

#### 2.4 MATERIAL IMPACT DAMPING

As a coating or potting material, Rigidax exhibits excellent damping and stabilizing qualities in large and small parts during fabrication. Because prototype tests indicated a substantial material damping effect, a preliminary attempt was made to compare the Rigidax-held part to a conventionally clamped part. The ratio of damping was determined by encapsulating 12 aluminum angles into varying thicknesses of Rigidax. Vibration was induced by striking the exposed leg of the angle. Frequency patterns were converted to percentages for each damping decay pattern of compound-held or clamped angles. The rigidizing effect on the angles by the surrounding material is immediately apparent. Damping effects ranged to as high as a 3:1 ratio over 80 percent of the samples. The results indicated that increasing the thickness of the tooling compound beyond 2-1/2 inches does

not proportionately increase the damping quality. They also indicated that other uses of this material can reduce unpredictable component movements (such as for isolating a portion of a completed panel assembly for vibration test).

Before attempting hydropress forming with a Rigidax die, compression tests were made to determine the pattern of compressibility and rupture of three grades of Rigidax: Rx blue, Px pink, and G green, all of Type W1 (water insoluble).

Four samples of each were compression loaded on the Insoll machine at a rate of 500 pounds per minute.

The material compressed until, at an interim 1200-pound load, a slight settling occurred; then continued until edge cracks appeared. During loading, the material moved outward slowly until the 6000-psi level was passed, indicating that the cohesive strength of the material, and its characteristic flow, is continuous.

All samples (0.375-inch-thick by 2.250-inch-diameter coupons) cracked or ruptured above the 3500-psi recommended compressive strength.

Efforts to reduce the cool-down time of Rigidax were conducted, concentrating on cold water quench. Previous study of ambient cool-down time (4 to 6 hours for materials in 1- and 2-inch thicknesses) remain, valid. Ambient temperature cooling for 30 minutes, then dipped in cold water (40°F) for 90 minutes, will reduce the cool-down period. Finally, cold water (40°F) soaking of 1- and 2-inch-thick material blocks allowed the material to reach full hardness within 30 minutes.

#### 2.5 SPECIAL TOOLS

##### 2.5.1 Special Tooling for Landing Gear Forging

The size and complexity of the DC-10 landing gear forging with its very expensive programmed tools for milling operations, often prohibits the use of backup or supplemental tooling. Machine overload and/or tool rework delays can cause critical schedule stresses. A Rigidax special tool was completed and tested to evaluate the degree of assistance such an interim tool could provide to relieve a lagging production schedule.

The type of tool selected was a snug-fit nesting milling tool. The part was set 2 inches deep in a 4-inch pad of Rigidax that had been poured under a finished part. The tool was specifically designed without clamps on one side of the tool, to allow maximum spindle freedom. This material development study was planned to perform only those material cuts that did not interrupt the performance of programmed tooling on subsequent machining operations.

The sequence of operations used in preparation for this technique is briefly described below:

- Rigidax (430 pounds) was melted in an air-circulating oven for 3 hours at 250°F, in a 55-gallon drum.

- A large metal plate was provided with adjustable swivel pads.
- The landing gear fitting was placed over the adjustable pads and the part was leveled.
- A wooden container was built around the part.
- A draft angle was built about the part, and through-holes were plugged with Babbitt-Rite material.
- The part was undercoated with mold release spray (DPM 3494).

The complete application, from tool concept to machine operation, took approximately 10 hours, including cool-down time.

Tooling cost avoidance factors are realized based on the number of parts, the amount of material to be removed, and the number of surfaces to be machined. Tooling studies, fixture design, and tool fabrication are minimized. Tool storage space is not required, as the material is melted and returned to supply after use.

#### 2.5.2 Dual Surface Machining of Wind-Tunnel Wing Model

With the increasing use of high-speed, numerically controlled machines, the age-old and time-consuming task of resetting a production part when its opposite surface requires alternate machining, is unacceptable. A tooling plan was initiated to develop a method for resupplying Rigidax material to the underside of a wind-tunnel wing model each time it was turned over. The new material was poured into the cavity created by the previous cuts. The temperature of the material remained high enough to melt the previously poured surface, causing material cohesion. The wing material was an aluminum tooling plate, 4 inches thick, 28 inches wide, and 60 inches long. During rough machining, two 5-inch wide pads running along the leading and trailing edges of the subscale wing were cast to provide longitudinal support. This support was subsequently removed after 50 percent of the milling cut was finished and a block pad of Rigidax was cast as a center support for the part.

The material box in this tool permitted the material to be easily poured under the part, where the damping properties of the Rigidax would perform best. Subsequent dimensional inspection of the wing model showed that the aluminum tooling plate twisted only 0.010 inch at the outboard end. Conventionally held wind-tunnel models of this size usually twist approximately 0.125 inch.

A cost avoidance of 137 man-hours was estimated by Industrial Engineering in a comparison of the faster casting methods for locating and supporting the under surface of the wing, to the time-consuming, manual adjustment of height jacks.

## 2.6 INTERIM TOOLS

### 2.6.1 Machining a Thin Member

The greatest challenges to a machinist's talent are posed in the development laboratories. Here, intricate and delicate metal-removing tasks are the rule. Into this area, Research and Development personnel introduced low-temperature melting Rigidax for aiding in the close-tolerance machining of a detonator test assembly. A thin window-frame member with a cross-sectional area of 0.006 square inch was designed to rupture at a given explosive charge pressure. Backup support to the 0.020- ± 0.005-inch-thick window frame was completed in less than 2 hours. By conventional methods, this operation would have included a rough cutting pass, followed by a filing or lapping operation.

### 2.6.2 Dimensional Layout

In machine shop procedures, considerable layout time is required to dimensionally scribe the milling and drilling areas of odd-shaped parts prior to machining. Several difficult parts were selected to study methods of reducing this indirect cost. The parts were potted in Rigidax to suit the holding fixture during ink bluing and dimensional scribing operations. It was found that the layout man-hours can be reduced by 30 percent or more, depending on the mechanic's working knowledge of the material.

## 2.7 PRODUCTION TOOLS

Three problems must be faced when trimming large diameter thin-wall tubing:

- The tube's diameter (5 to 7 inches) is slightly stretched from its original diameter.
- A parallel cut with the tube centerline is required.
- The thin wall of the tubing prohibits mechanical clamping.

Several experimental holding tools were made for supporting large diameter tubing and for aligning them 0.060 inch away from the 28-inch-diameter blade used for trimming. Temperature rise within the Rigidax, due to cutting, is checked by a water-soluble quenching spray. Several unsuccessful attempts were made to lock the Rigidax holding tool with the machine's clamping bar and table. Results indicated that the bottom half of a female die was preferred, using a rubber strap to hold the workpiece.

In casting Rigidax to the shape of the bulge formed tube, sufficient surface friction is generated to hold the part. Rubber straps help to contain the tube in the holding tool. The direction of stretch in these straps, when trimming T-shaped tubing, should be toward the center diameter of the tube, in order to seat the opening in the tool cavity.

Damage to the tooling compound is easily repairable by simply clearing out the damaged area and replacing the broken material. A hand-held Iodine Quartz lamp is used to remelt the replacement material.

As a result of these studies, Rigidax is being implemented into production tooling operations. Eight Rigidax tools are in production, and several more are in design. A Tooling Data Sheet is being upgraded to outline procedures for building these trim tools.

The tool fabricating thinking has changed considerably from the previous applications wherein the machine shop preferred a support tool for the production part during machining only, and the material was subsequently remelted and returned to storage. In the trim operation, permanent tooling is preferred. Rigidax costs were compared to costs of two other castable materials currently being used by the tooling department, with the following results:

Material	Reusable	Est Price/Lb (\$)
Rigidax Green Type W1	Yes	2.00
Carveable Epoxy Resin		
REN DP-146-70	No	4.32
Cerrobend	Yes	4.00

The use of bulge forming techniques to form intricately shaped parts with close tolerances makes it difficult to support these parts by conventional clamping tools. Rigidax makes loading and unloading of the tube easier and faster. It also eliminates the need for applied template, previously needed to mark trim lines on the tubes.

## 2.8 FORMING DIES

The hydropress is used in production to form sheet stock parts by applying a uniform pressure over all sides of a male die. Because of a continuous flow of low-volume developmental parts, the only significant cost item is the die. Elimination of the die costs by creating a temporary tool aid is obviously an advantage. The working pressure of the hydropress unit (3500 psi) is below the breakage or fracture point of the material. An exploratory study was made to determine the degree of formability of aluminum sheet stock between 0.032 and 0.063 inch thickness around a Rigidax die. Two dies, with three-sided shapes 1-1/2 inches high were made, and two doubler dies, with reverse flanges and 0.060-inch joggles at each end were also fabricated.

A smaller, U-channel die, with a 0.125-inch joggle on the center web was completed. Satisfactory forming of parts over these dies was accomplished using 6061 aluminum, O and AQ condition 12,000-psi yield-strength material.

A minimum radius of 1T was accomplished over a staircase-type forming block, demonstrating good material flow over the material's waxy surface. The thickness of the die is important, and a sturdy base is required to stabilize material movement within the die. Nonetheless, the stability of a 2-inch-thick die base will form approximately 6 to 7 parts before die material movement is detected. These preliminary tests were limited in

scope, but were indicative that the material's compressive strength, though marginal, can replace hard metallic dies, at least in some cases.

Forming for limited production reduces tool material cost and fabrication time and, because the material is reusable, tool storage of these tooling compound dies is unnecessary.

## 2.9 EQUIPMENT

A portable melting unit was adequate for handling 80 percent of our investigative efforts of parts requiring up to a 75-pound tank of material. A second tank unit was designed and built to handle more than 400 pounds of material, employing a 55-gallon drum and using an air-circulating oven to melt the material in approximately 3 hours at 250°F. Light-duty shop cranes were used to transport the molten material to the pouring site.

When material is cast into large tools, removal of the material for reuse is difficult. Attempts to saw-cut Rigidax on the band saw or other mechanical saws proved futile. Even at minimum speeds, the saw blade heat melted enough material to clog the teeth. Breaking the Rigidax away with a hammer and chisel caused material chips to fly in all directions.

Numerous hand saws with varying types and numbers of teeth per inch were investigated. Best results were achieved with six teeth per inch, in a staggered-tooth blade configuration.

The hand saw must be passed through the material slowly to keep the saw teeth from loading. The adhesive property of this material will lock to the teeth of power saws and hand saws if rapidly cut.

Melting by infrared heaters is restricted by the size of the ovens available and by problems in controlling and handling the flow of molten material. A hand-held commercially marketed infrared gun can apply a melt temperature of 250-300°F over a 2-inch-diameter area, when held approximately 2 inches above the material. Being hand-held, the direction of material flow can be controlled. Originally designed for melting plastic (Olefin) material, the unit is heated by an enclosed Iodine Quartz lamp, operating on 110-volt ac current.

Melt temperature is achieved within seconds; an optical filter system, designed to reduce the visible portion of the spectrum, protects the operator's eyes.

Localized heating of a Rigidax tool proved the gun's effectiveness in repair situations. Material originally removed with a chisel was merely positioned over the hole and remelted. The price of this unit is approximately \$80.00. Replacement lamps cost \$7.50 each, and last about 2000 hours.

## 2.10 HEATING AND STOWAGE UNIT

It is impractical, if not impossible, to predetermine and schedule parts which will be difficult to hold by conventional methods. The decision to use Rigidax may arise from any of several

planning areas. Thus, in order to supply this holding material to the entire shop, a portable unit with an oven and melt pot was designed. It was built to fit the space available between the machines, and is 33 inches wide, 54 inches long, and 64 inches high. A removable 5-gallon pot of molten material can be lifted from its pipe mount for special pouring operations.

An oven for melting the Rigidax from the parts is mounted on the unit. The oven is 36 inches square by 18 inches high and is designed to drain directly into the pot. Melting is accomplished by four infrared lamps of 750 watts each, which are removable for special melting problems. 440-volt, 30-ampere electrical power for the sta-melt pot and oven is provided through a single, arc-tite connector.

A new silica foam material was used to enclose the sides of the oven. This 1-1/2-inch-thick material retains all heat inside the oven, thus ensuring the safety of personnel.

Additional accessory tools were made to assist the positioning of the part to be machined before encapsulating the part in Rigidax. Several precision V-blocks, gage blocks, and cutter gage blocks were made which are used to position the workpiece or to reference the cutter to those surfaces which are hidden in Rigidax.

### 3. SUMMARY

Our studies have proved that Rigidax can be extremely valuable in providing temporary milling tools for machining odd-shaped parts such as the DC-10 landing gear forging. It is very useful as a holding device for precision-tolerance layout of critical parts for machining. The support provided by this material during critical

machining of developmental thin-wall parts, reduced manhour requirements and increased the operator's confidence level.

In production, the material is ideally suited as a holding fixture for support of thin-wall tubes while making saw cuts.

Hydropress forming with Rigidax dies can be accomplished for production of approximately six to eight parts, in an annealed condition.

It is impractical at this time to estimate the cost savings which can be realized by using Rigidax in preplanned production tooling.

### 4. BIOGRAPHY

In his 7 years with the Douglas Aircraft Co., Long Beach, California, Mr. Gomez has developed accessory equipment to reduce product cost in plastics and in laser alignment and measurement techniques. As a member of the facility coordinating team, he assisted in setting up the new Manufacturing Development Center, designed to produce graphite/epoxy components for commercial and military aircraft.

Mr. Gomez received a B.S. degree in Industrial Technology - Manufacturing from California State University, Long Beach in 1966. He also holds a Certificate of Completion for "National Security Management," a 2-year course conducted by the Industrial College of the Armed Forces.

He holds professional memberships in the Society of Materials and Process Engineers, the Society of Manufacturing Engineers, and Toastmasters International (A.T.M. Distinction). He is Associate Professor at California State University, Long Beach, and is a member of the Advisory Council, Industrial Technology Department, at CSULB. He also holds Community College Teacher's credentials.

## APPLICATIONS OF CURVED SYSTEMS

Derek Ball, Thomas Feldman,  
and Edwin Pickett  
San Francisco Art Institute

Abstract

*Dealing effectively with contemporary social and cultural change is perhaps the greatest challenge we face today. The technological response to the ever-changing pattern requires integration of the roles of social scientists, engineers and artists in order to bring about creative and potent uses of scarce energy and resources. To the artist, esthetic considerations are integral to simplicity of form and purity of function--it is our belief that art must take an active part in the formation of practical solutions to today's most pressing problems.*

## 1. INTRODUCTION

Our challenge, as artists, is to make the necessary beautiful, to give to the functional the power of awakening the imagination, and to transform the utilitarian into the inspirational. One of our fundamental tasks is to find meaningful vehicles for artistic expression. It is a task which is rendered complex in a world of rapid change, in a time when every day brings new inventions, new materials and new tools to bear on the quality of our lives. It is a task, however, which must play an integral role in the shaping of the present and the future.

Artists through time have served to express (and to heighten awareness through

that expression) the nature of man's relationship with his environment, with other men, and with himself. Importantly, their work serves and orients.

We believe that the key ingredient of the cultural and technological revolution being experienced by twentieth century western man is one of attitude, one of perspective, one of point of view. Survival, once a personal or community matter, is now a matter of a complex set of tightly interwoven interrelationships. The perspective of our time is necessarily global.

The rigidity of rectilinear life support systems born in past centuries bears little resemblance to the open and fluid systems

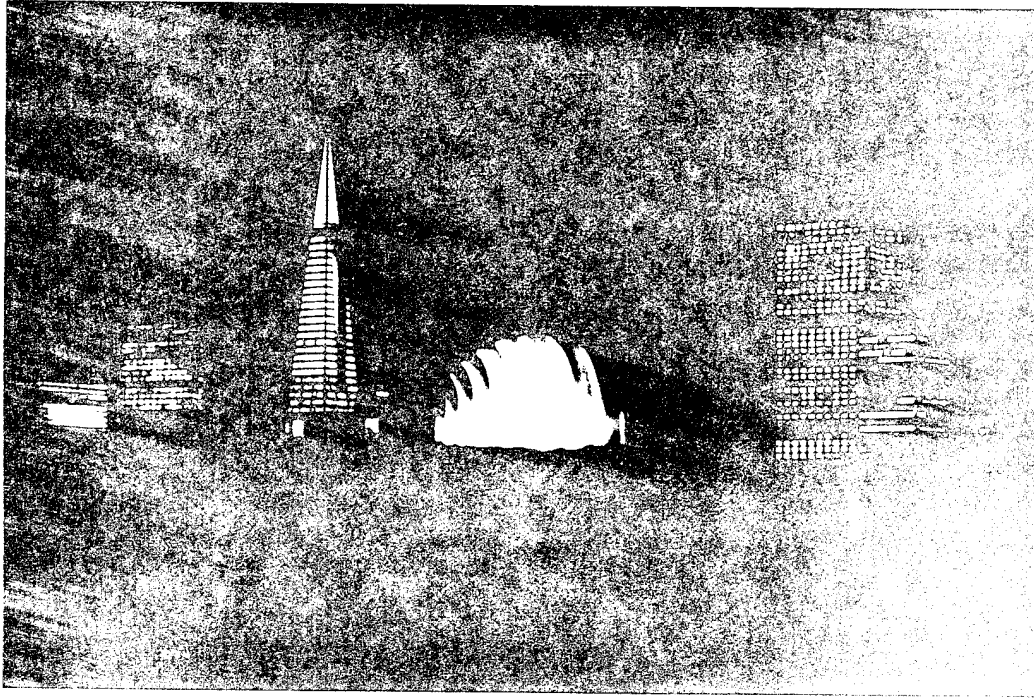

ARTIST'S VIEW OF SCALE MODEL OF SCULPTURE/STRUCTURE AGAINST THE SAN FRANCISCO SKYLINE.

thinking characteristic of the 1970's. Grid planning is now judged, in many of its traditional applications, inefficient, oftentimes hazardous, and, frequently lacking in beauty. Man is beginning to learn that the solution to large problems does not lie in breaking them up into little problems. We are beginning to learn that the human experience cannot be divided into cubes and minutes, that we are dealing with a flow, a space-time continuum. We are learning to apply a new approach to construction based on the natural geometry of space.

Indeed, we are witnessing a very basic reorientation in point of view. For the artist, it poses a new responsibility-- and the perspective proffers a wide realm of possibilities.

## 2. PROJECT ONE: SELF-SUPPORTING STRUCTURE

A teaching project was begun in the summer of 1973 to build a structure based on the principle that a convoluted form enables a very thin skin to be entirely self-supporting and capable of spanning a very large distance.

The project was given a grant of \$1900 by the Union of Independent Colleges of Art and was supported by the San Francisco Art Institute where construction work was carried out and where the final structure will ultimately feature. The Reinforced Plastics/Composites Institute of The Society of the Plastics Industry, Inc., organized and for the most part procured raw materials for the construction of the sculpture-structure.

The structure was considered throughout as a piece of sculpture with the functional aspect of finally serving as a studio especially suitable as an environment in which to work with transparent materials. Esthetic considerations dominated the planning and building of the structure so that the finished work would be thought of primarily as a beautiful form and only secondarily as a utilitarian object. To facilitate this degree of control over the finished form, work from the very first drawings was carried out at full size and

adjustments made throughout in accordance with a feeling for proportion relating to human scale. It is for this reason that no scale models were made until after the full size form had been built because relationships within a form and our relationship to a form change with a change of scale.

The final form is 30'x20'x12', elliptical in plan and elevation and semicircular in section, constructed separately in two halves each comprising five panels of

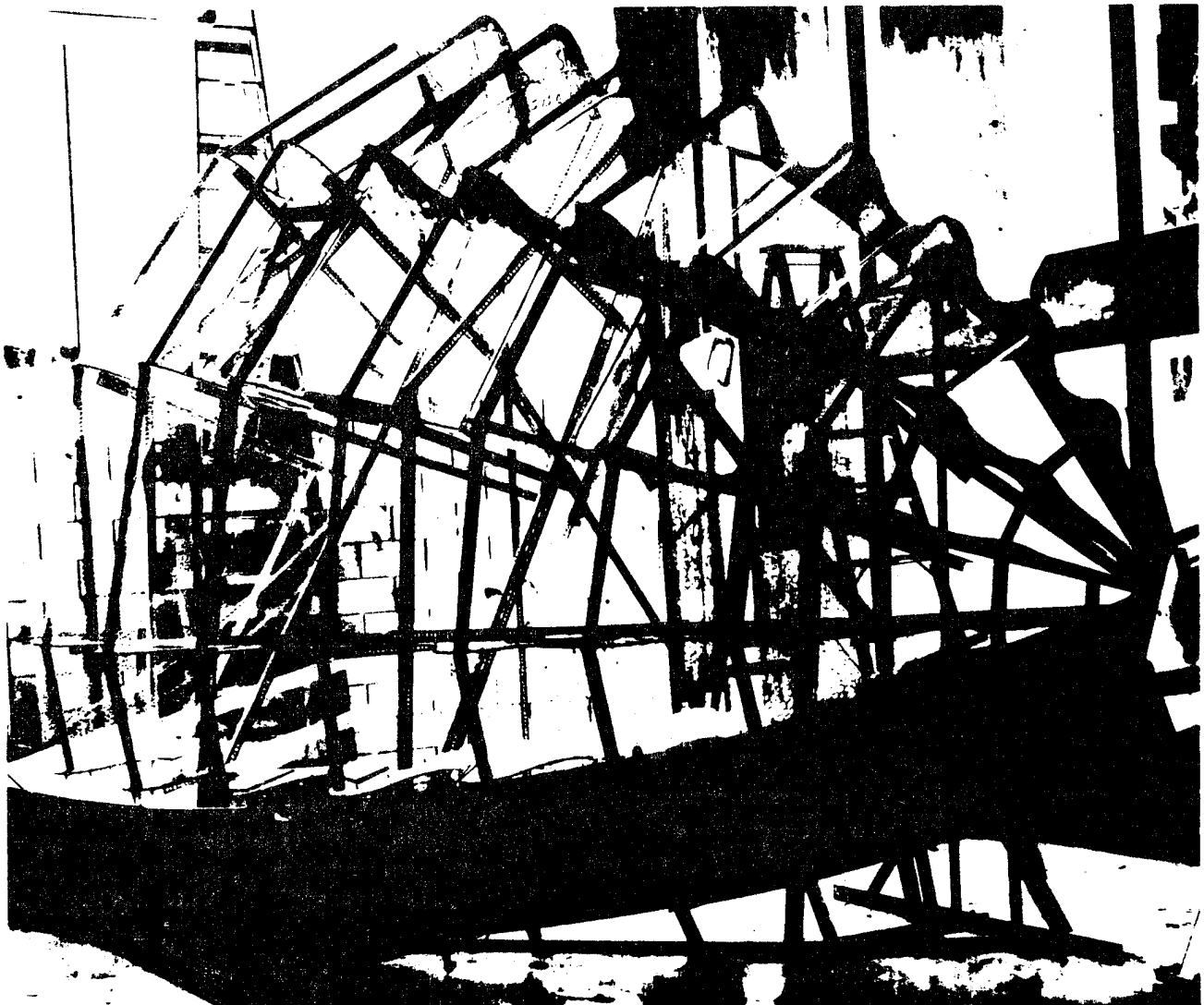

SKELETAL VIEW OF WOODEN CONSTRUCTION WITH CHICKEN WIRE SUPPORTED BY METAL SCAFFOLD SYSTEM BEFORE PLASTER WAS APPLIED.

varying widths though all taken from the same mold. Strengthening is by means of transverse convolutions which diminish as the section becomes smaller. The calculation of these is in accordance with ratios of proportion to the total scale of the structure.

The original intention was to use a matched dye system or vacuum forming machine to form panels from thermoplastics (polycarbonate or acrylic) transparent or

translucent enough to provide unassisted daylight illumination of the interior. However, restriction of sheet sizes and the difficulty of procuring a machine large enough to make panels of usable dimensions led us to decide upon the alternative of a one mold system for forming fibre glass panels.

The evolution from transparent material to fibre glass carried with it the possibility of the inclusion of color, though

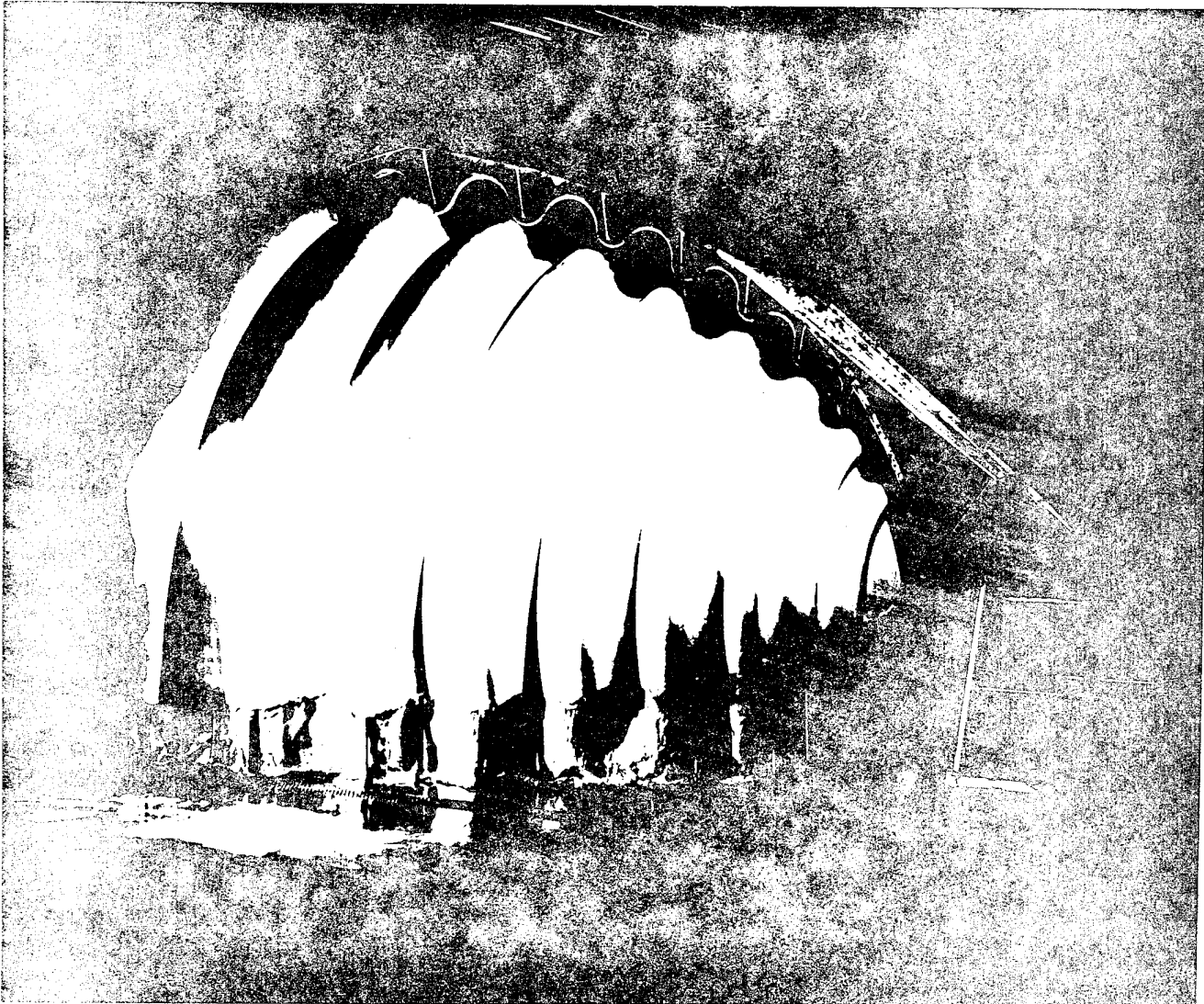

QUARTER PLASTER CAST FROM WHICH MOLDS ARE TAKEN FOR THE FIBRE GLASS SCULPTURE/STRUCTURE. TWO TONS OF PLASTER WERE USED IN THIS CAST 10'x15'x12' HIGH.

the value of the universal acceptance of industrial highly finished uniformly colored surfaces was questioned. As a result a painter began working with the inclusion of patterns on the surface which do so much to animate as well as camouflage natural forms such as shells, insects and fish. The main color is a reflective blue camouflaging the structure so that it sits into the sky rather than being seen against it. Lighter blue is splashed in from both ends of the form which, together with a subtle misting of silver in the concave convolutions, modulates the blue in the same way as there is a modulation between the horizon and the overhead sky.

*We are grateful for materials generously contributed in a time of short supply by:*

*Anderson Constructors  
Beaufort Manufacturing Co.  
Binks Manufacturing Co.  
Cook Paint and Varnish Company  
Douglass and Sturgess Limited  
Hexcel Corp.  
Kaiser Glass Fiber  
Koppers Company, Inc.  
Monaco Laboratories, Inc.  
Multimedia Presentations, Inc.  
New Generations Publishing Co.  
PPG Industries, Inc.  
Ram Chemicals  
Reichhold Chemicals  
Royell Inc.  
Silmar Division Vistron Corp.  
The Norac Co.  
Venus Products*

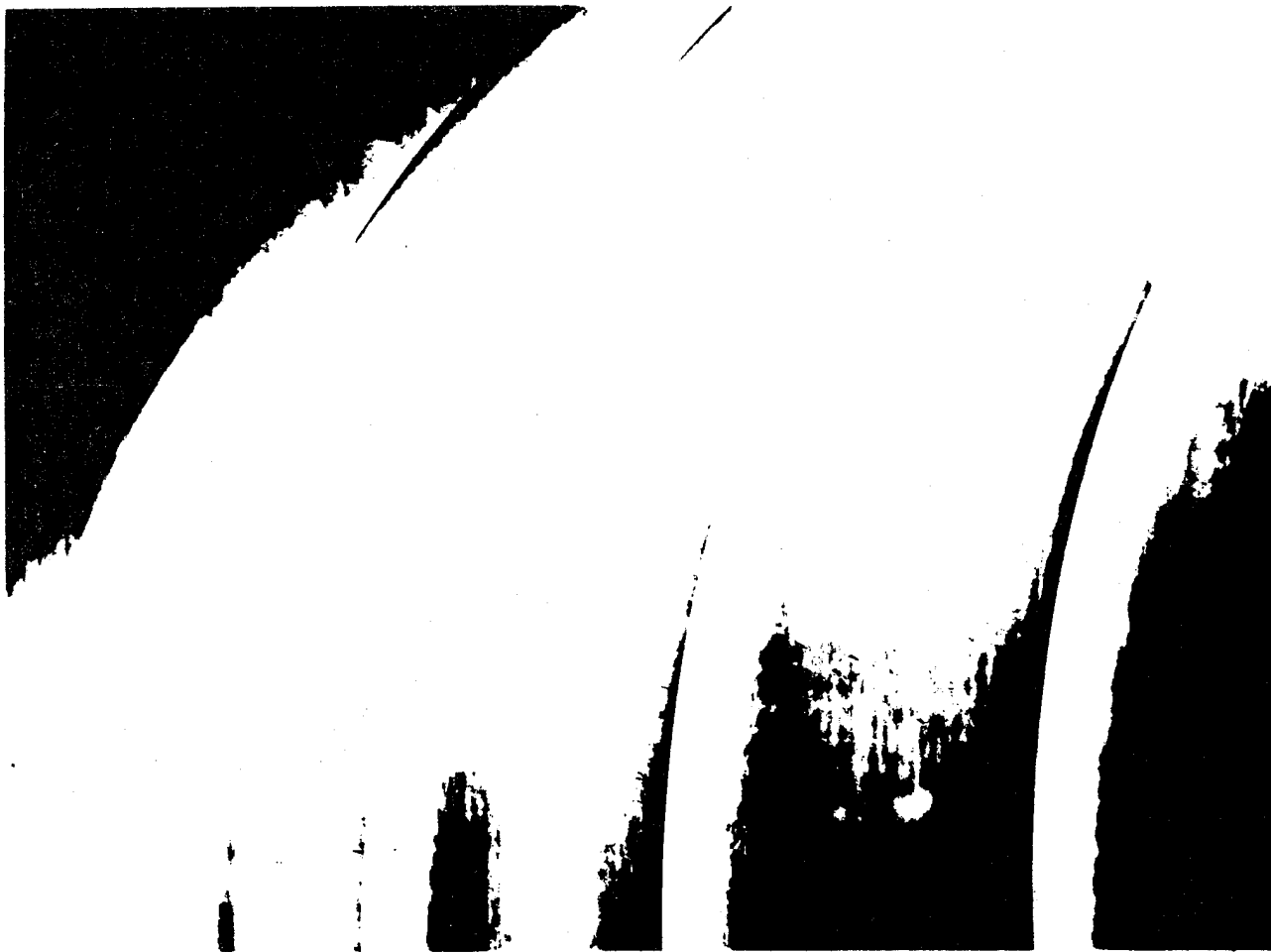

CLOSE-UP OF THE CONVOLUTED SURFACE OF THE SCULPTURE/STRUCTURE

## 2.1 CALCULATION OF THE CONVOLUTIONS

Once the self supporting principle of convolutions was established, it was necessary to formulate a solution that would give the necessary relationship between visual rightness of form, economy of materials and structural strength.

The surface should significantly modulate the effect of light, where convolutions too deep would create black voids that would break up the total continuity and convolutions too shallow would create a visually anaemic form.

If the convolutions were too deep, an excess of material would be used (both for the increased surface area and to strengthen the vertical section between convex and concave curves that would otherwise buckle). Whatever strengthening was done, the end result of deep convolutions would be a form likely to concertina.

Shallow convolutions would be more liable to buckle both when being pulled from the mold and around the subsequent fixings. To counteract this tendency the thickness of the panels would have to be substantially increased.

A solution that seemed right visually was given a mathematical formula as follows:

Concave convolutions are  $\frac{2}{3}$  the diameter of convex convolutions. Convolutions diminish progressively by 10% as the section of the building becomes smaller and the center point for each curve is offset from the ellipse line beginning at 3" with the largest convolution and progressively reducing by  $\frac{3}{10}$ ".

SCHEME FOR CONVOLUTIONS FORMING  
PLAN AND ELEVATION PROFILES

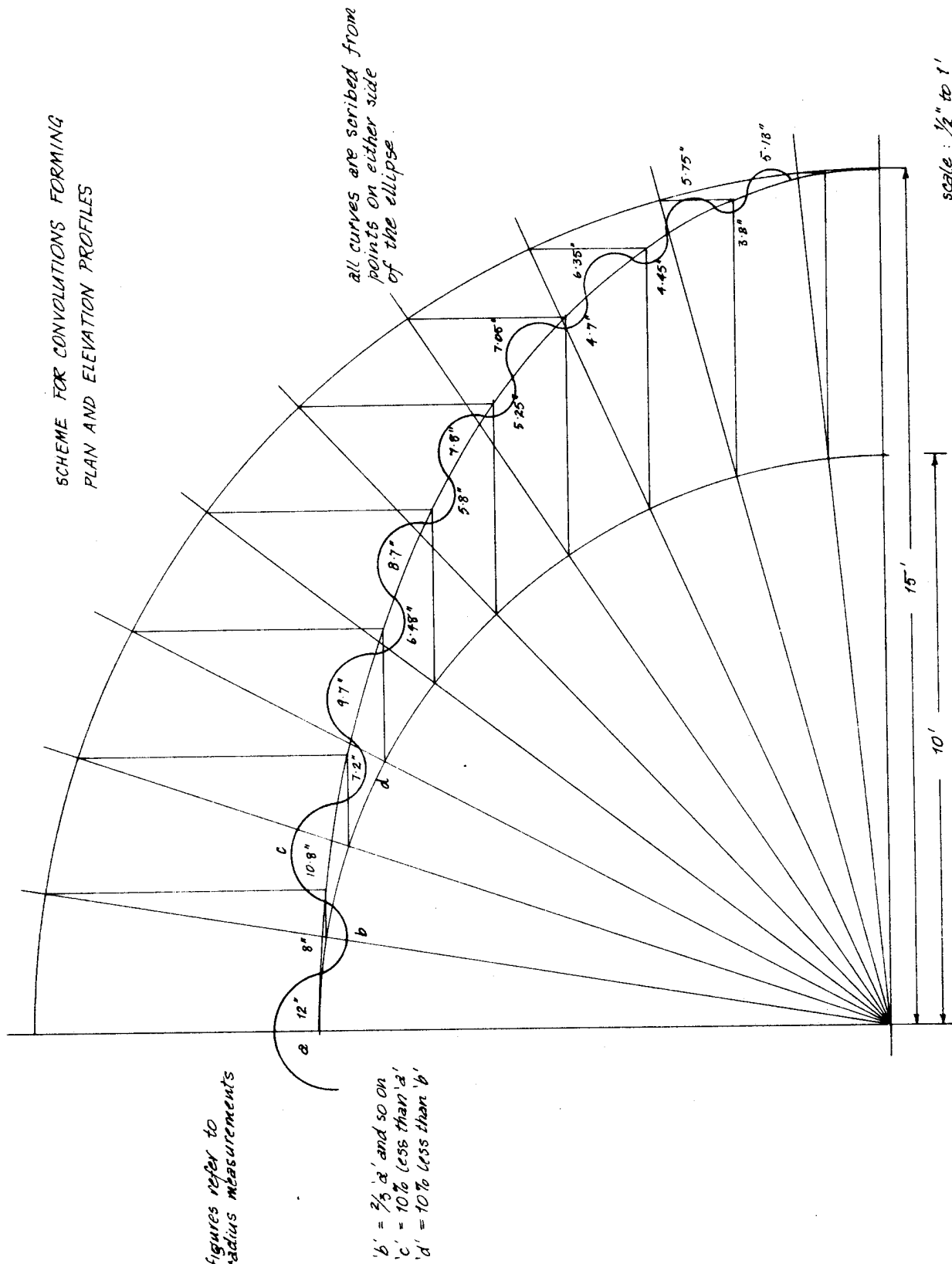

all curves are scribed from  
points on either side  
of the ellipse.

figures refer to  
radius measurements

'b' =  $\frac{2}{3}$  'a' and so on  
'c' = 10% less than 'a'  
'd' = 10% less than 'b'

scale:  $\frac{1}{2}$ " to 1'  
Jan 26<sup>th</sup> 1974. Derek Ball

## 2.2 ROTATING BLADE

A metal blade cut to the convolutions of the structure, backed with wood, strengthened by a T section and braced diagonally to eliminate flex, was pivoted from the axis to sweep across the contour of the surface of the model with the function of screeding wet plaster to the exact form required.

The shutter was counterbalanced with anchor chains so that the maximum weight of the chains counterbalanced the heaviest position of the shutter. As the shutter was raised the effort required to lift it became less and correspondingly the weight of the anchor chains was reduced link by link as they were lowered to the floor.

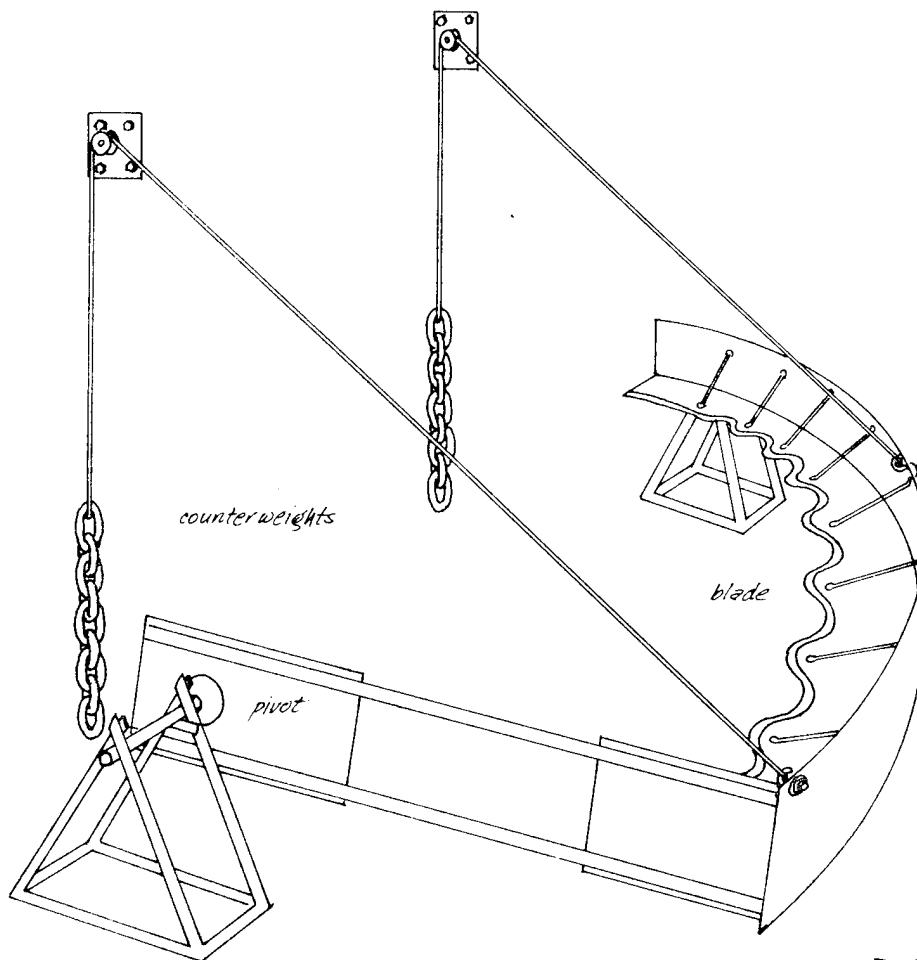

Jan 26<sup>th</sup> 1974  
Derek Ball

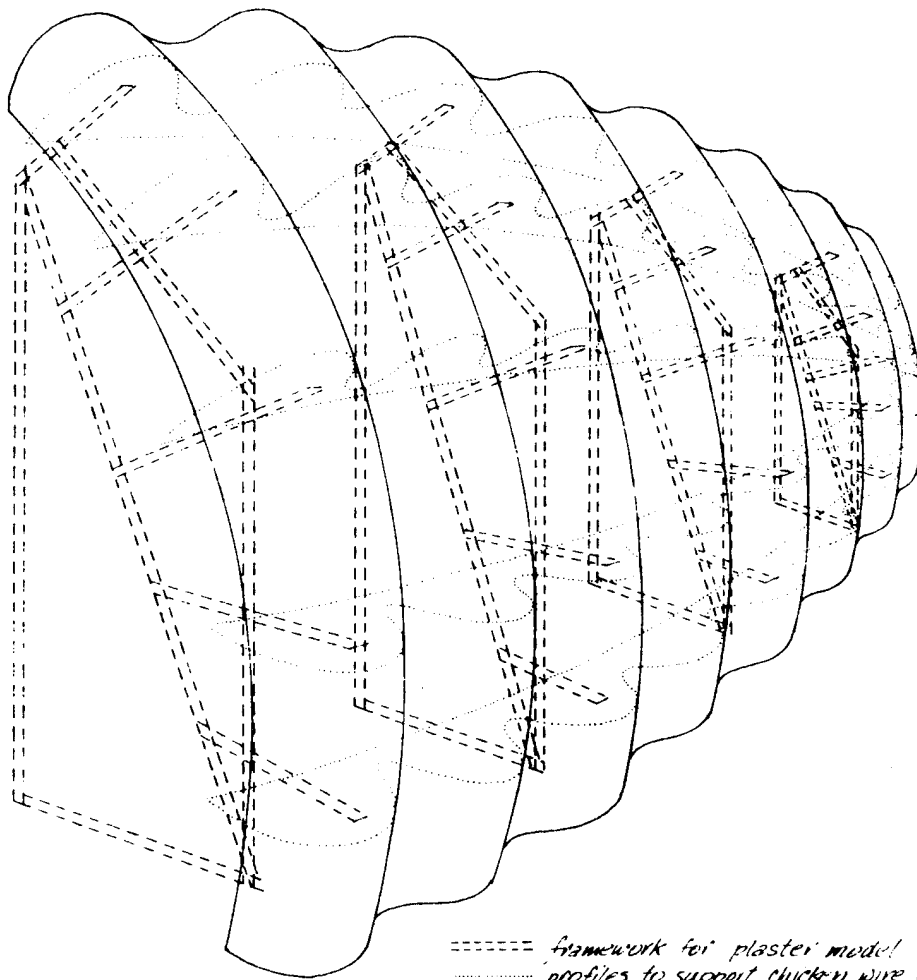

----- framework for plaster model  
 ..... profiles to support chicken wire and plaster  
 ————— highly finished plaster skin

Jan 26<sup>th</sup> 1974  
 Derek Ball

### 2.3 FRAMEWORK

The framework over which the shutter moved was as lightweight and economical of materials as possible.

A dexion framework and plywood profiles were enough to support 2000 lbs of plaster comprising the surface of the model and the later additional weight of the mold.

### 2.4 JOINING THE PANELS TOGETHER

So that all panels fit flush with each other a recessed lip had to be molded in as an extension to most of the panels.

This was done by laying onto the mold a sheet of 1/8" thick rubber (flexible enough to drape into the contour of the mold), cut to match the scallop edge of the panel, and fibre glassing up over the edge of this to form a built-in lip.

It is necessary only to have two of these edge profiles cut from a single sheet. They must be used one way up for one half of the structure and inverted for the other half, otherwise the scallops will not match up at the center.



## 2.5 DRAWING STRAIGHT LINE OVER A CONVOLUTED SURFACE

A taut nylon line strung with corks was stretched between mold edges along the line required to be drawn on the mold. Through each cork was a fine vertical line hung with a pointed weight.

This makes a fully adjustable system for plotting points on the mold. The lines can be adjusted through the corks quickly yet are held firm by them. The weights are adjusted to just above the mold surface and dots made on the mold to correspond with their position. The dots are later connected into a line.

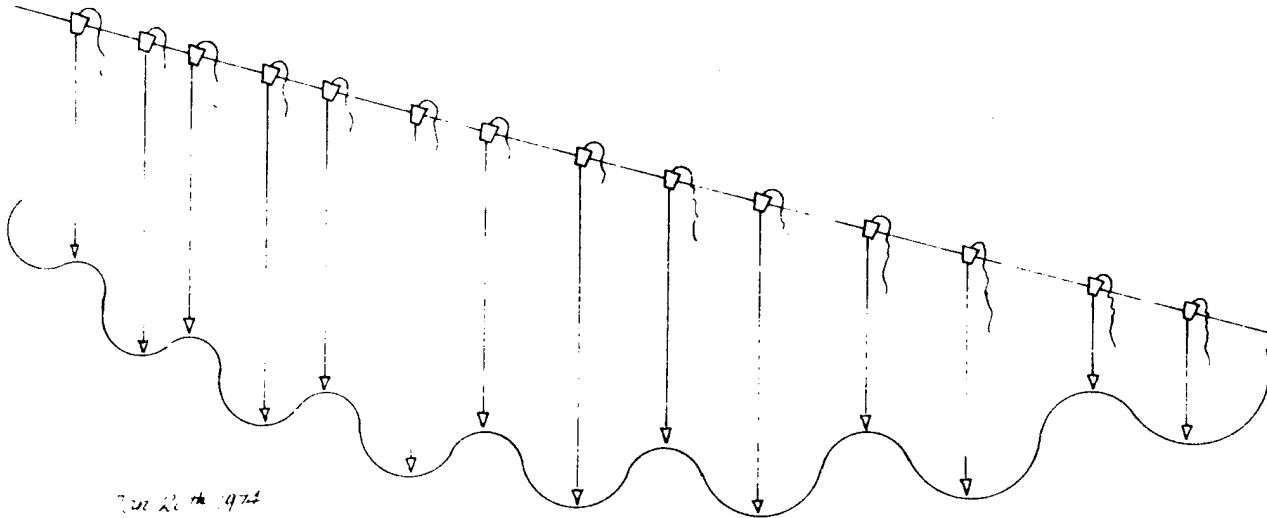

*See also 1974  
Cork Ball*

## 2.6 OBTAINING THE EDGE OF THE PANELS

It was essential that the overlapping joining of the panels be homogeneous with the total form of the structure as are markings or ridges on organic forms.

A straight edge would not be suitable and any use of curves would have to be in relationship to the convolutions. A method to automatically ensure that relationship was found by draping a cord so that it touched the tops of all the convolutions. A light then cast the shadow of the cord a pre-arranged distance and, providing the light was lined up with the center of each convolution in turn, a symmetrical curve resulted that was conditioned by the convolutions and was therefore harmonious with them.

## 2.7 OBTAINING THE PORTION IN EXCESS OF THE SEMICIRCULAR SECTION

The base panels are largely comprised from below the axis. The mold does not include much of this area as it would require an almost 360 degree model to take the mold from. However, the missing area can be obtained by rotating the panel so that the top edge of the ground line to be drawn in somewhat diagonally across the surface of the mold.

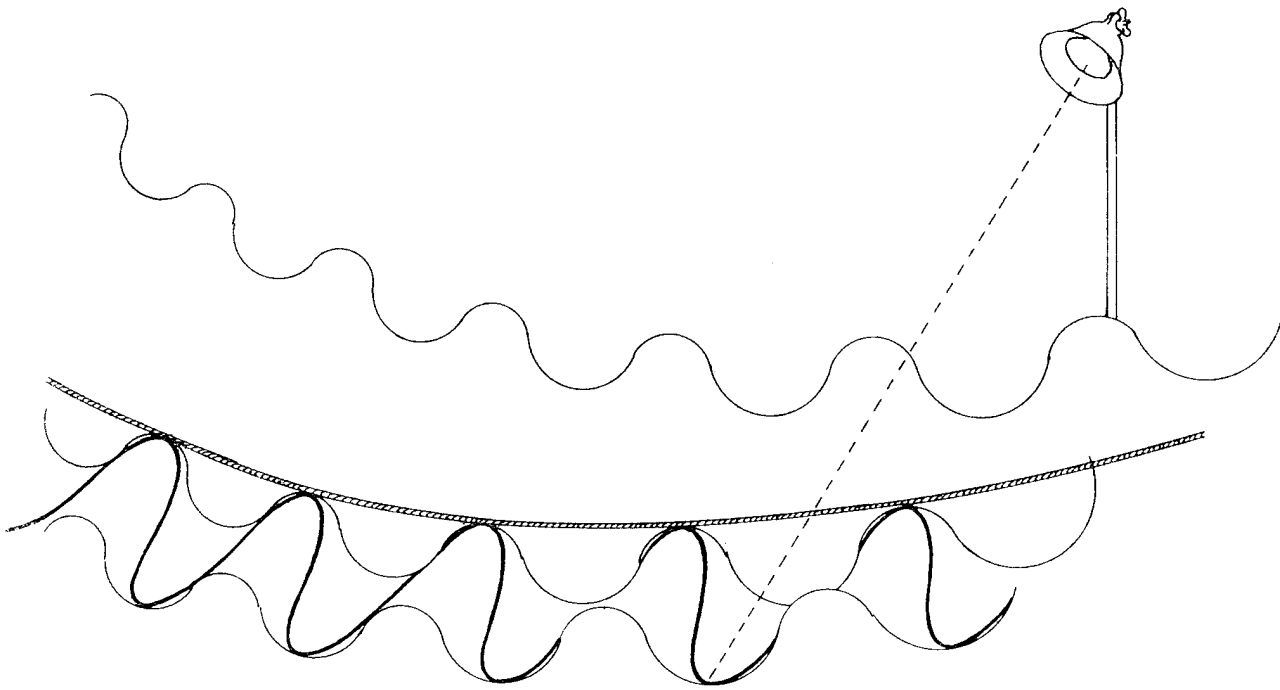

2.6 OBTAINING THE EDGE OF THE PANELS

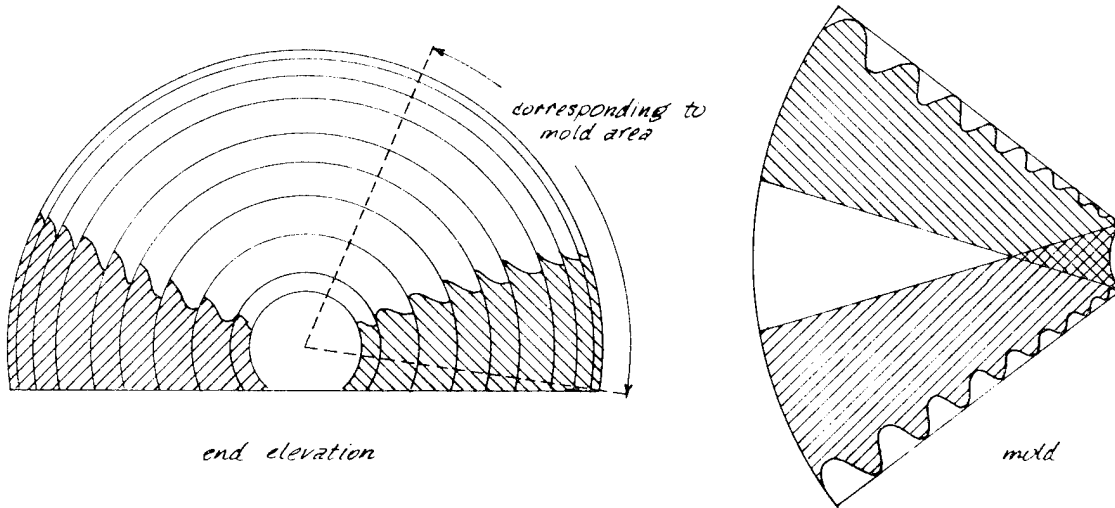

scale: 3/16" to 1'  
 Jan 26<sup>th</sup> 1974. Derek Ball

2.7 OBTAINING THE PORTION IN EXCESS OF THE SEMICIRCULAR SECTION

2.8 OBTAINING THE PANELS FROM THE MOLD

The center panel of the structure (1) has no overlaps. The side panels (2a&b) have overlaps on one edge only--the opposite side for each panel. The base panels (3a&b) have a straight ground line and overlap at the scallop edge. The panels for the other half of the structure are obtained using the same method.

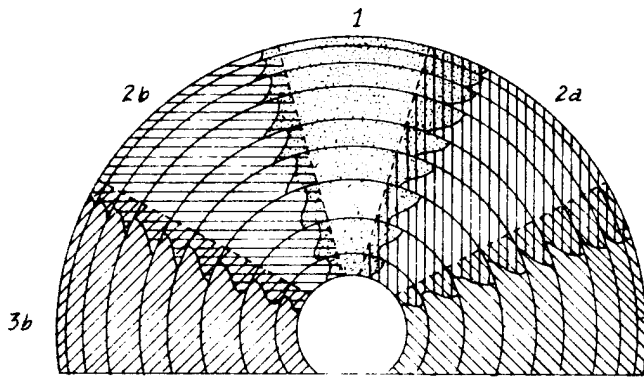

*panels assembly - end view*

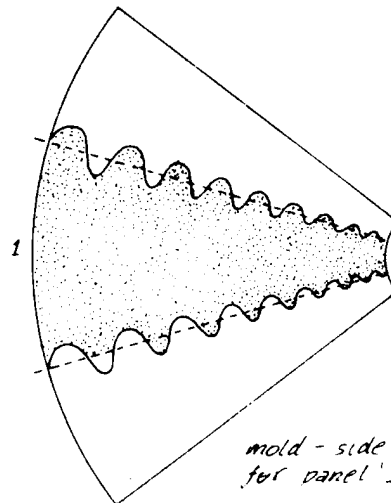

*mold - side view for panel '1'*

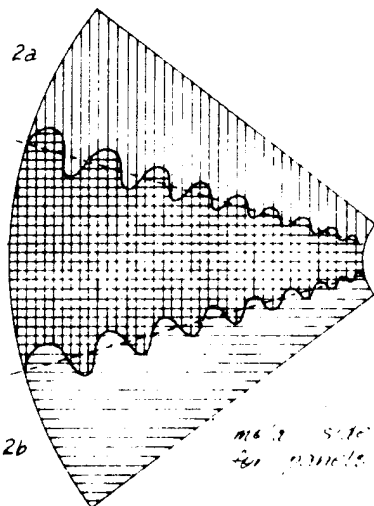

*mold side view for panels 2a and 2b*

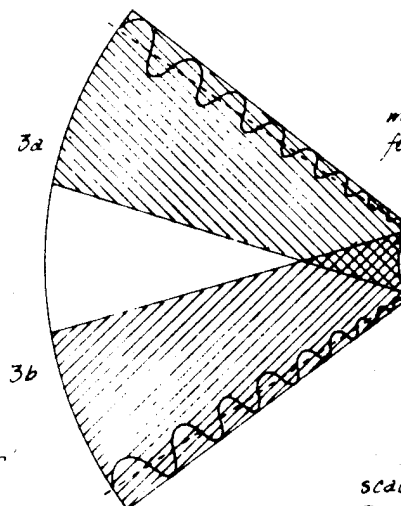

*mold - side view for panels '3a' and 'b'*

*scale 3/16" to 1'  
Jan 26<sup>th</sup> 1974  
Peret Ball*

### 3. FURTHER APPLICATIONS OF CURVED SYSTEMS

Currently we are considering the feasibility of constructing versions of other sculpture/structures. Several are described below.

#### 3.1 SPRUNG PIPE MEMBRANE SUPPORTING STRUCTURE

Four holders are made up of four or five tubes fixed into a radiating pattern so that P.V.C. pipes fitted into them arch between the holders creating the framework of a hemisphere.

The pipes are held at their intersections by a polypropylene connector which is bent to allow the pipes to be passed through the holes, then springs back when released to hold them in a rigid relationship to one another.

The framework can then be draped with thin polyethylene or Mylar, or a membrane can be slung from it, and held down at ground level to form an enclosed structure suitable for any temporary use.

It is waterproof and extremely lightweight for its size.

#### 3.2 SPIRAL STRUCTURE

The chief advantage of this system is that a structure can be made simply by cutting out a pattern directly from flat flexible sheets. No forming is required.

Tabs serve the dual function of locating the separate pieces and holding the structure together. If thermoplastics were used heat would be applied to the tabs to bend them over forming a permanent fastening.

#### 3.3 A FIVE SEGMENT SNAP TOGETHER MODULE SYSTEM FOR A HEMISPHERICAL STRUCTURE

A circular hemispherical structure convo-

luted so as to be self supporting, designed for the utilization of continuous cast acrylic which would enable panels 12 ft. or more in length to be formed as single pieces.

The method of fastening the panels is formed into the sheet. The panels snap together avoiding the necessity of introducing another material for fixings not usually compatible with the characteristics of plastics.

This is a quickly erected knockdown system for either temporary or permanent use. The panels can be continually reused without sustaining any damage. Application for kiosks, booths and conservatories.

#### 3.4 DOUBLE BRACED MODULE FOR ARCHED VAULT SYSTEM

An adaptation of the coffered tunnel vault so extensively used in antiquity, reduced to a thin skin self supporting curved system which best utilizes the unique properties of thermoplastics.

An easily produced module for any size of structure. The diameter of the arch is determined by the module but length is infinitely variable. This has particular application to market garden greenhouse systems where cultivation is usually in long rows.

When the modules are assembled the turned-in butting flanges form a double thick continuous curvilinear bracing system in two directions designed to give maximum strength from the lightest possible material.

The fixings are not permanent; therefore the modules can be stored easily and economically and should sustain no damage from continual reuse.

GROUND LINE MEMBRANE SUPPORTING STRUCTURE

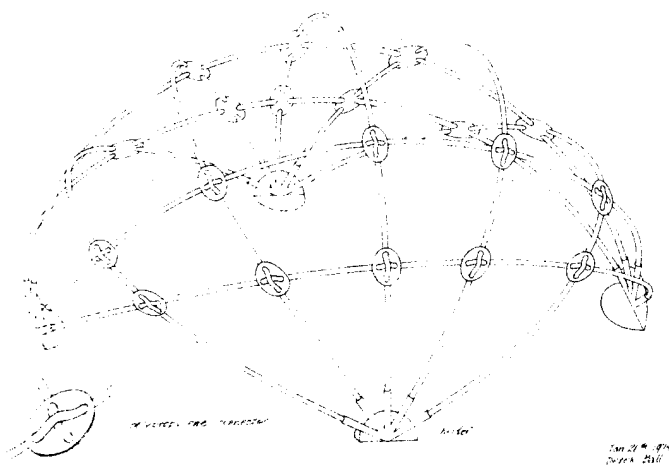

3.1 SPRUNG PIPE MEMBRANE SUPPORTING STRUCTURE

Jan 24<sup>th</sup> 1979  
Derek Ball

SPIRAL STRUCTURE

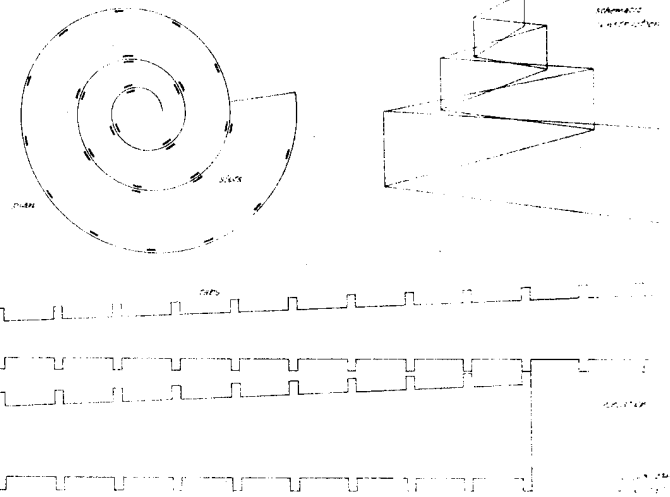

3.2 SPIRAL STRUCTURE

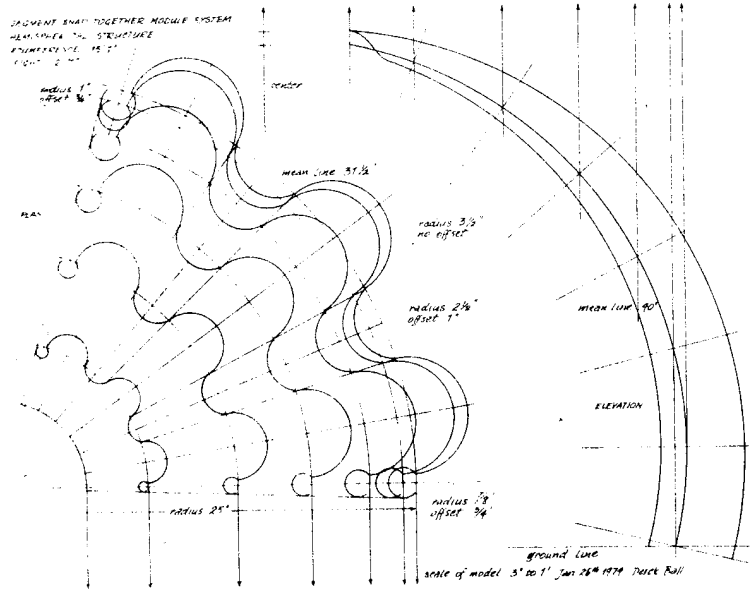

3.4 DOUBLE BRACED MODULE FOR ARCHED VAULT SYSTEM

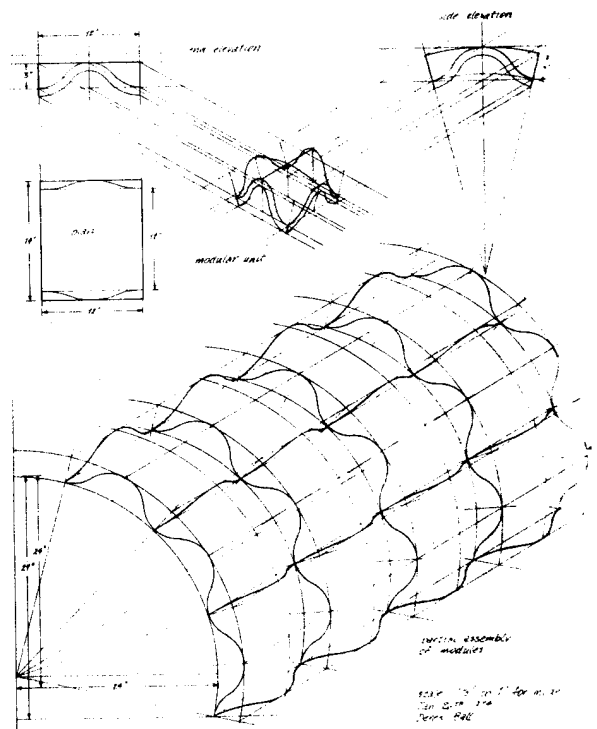

#### 4. EXTENSIONS

Possibilities for the application of plastic materials in curved systems extend in many directions. Dramatic use in theater is one.

The conceptual framework for a presentation created by Tom Feldman in 1972 clearly required innovative staging. Conventional notions needed to be set

aside in order to effectively integrate in the drama many forms of media and communication and to fully convey both the perplexing nature of modern dilemmas and the richness of human experience. The presentation was based upon an organic theme; an organic environment necessarily followed. The production's physical requirements were unique: individual components to be de-emphasized; continuity

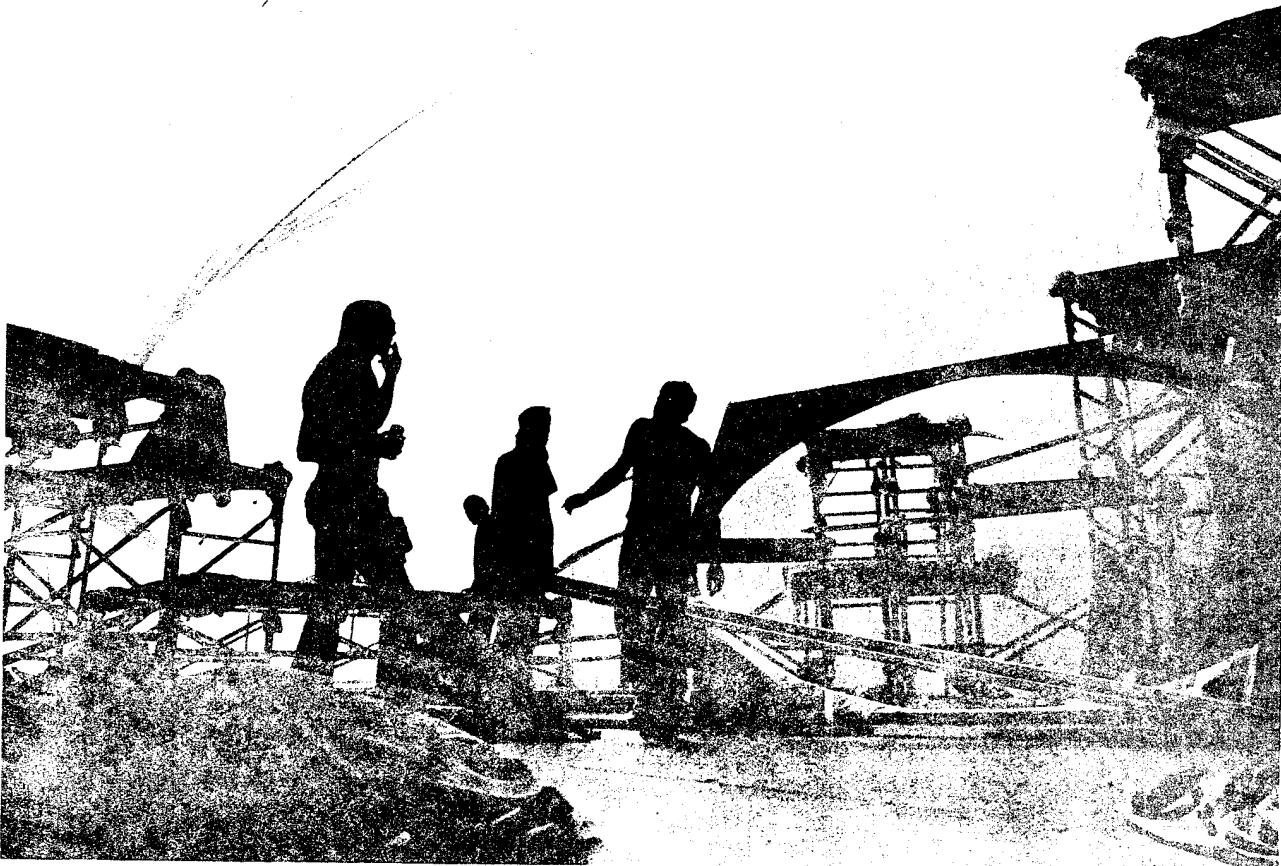

INTERIOR VIEW OF STAGE-ENVIRONMENT DURING CONSTRUCTION. LATER ON THIS SPACE WAS USED AS "STAGE WINGS"; ACTORS ENTERED STAGE BY THE USE OF TRAP DOORS FROM WITHIN.

and integration predominant; lineality, absent. Practical and theatrical considerations in stage construction called for lightweight, durable and portable materials.

In response to these specifications, Ed Pickett created an amoebic stage environment for this presentation. Inflating 3500 sq ft of 20 ml vinyl to graduated

levels (4' to 16'), a soft convoluted setting was constructed.

The thematic metaphor provided by this plastic sculpture/structure was basic to the production; it served both as a visual representation of an abstract concept and as a functional property. And it "played" a dramatic role in captivating an audience.

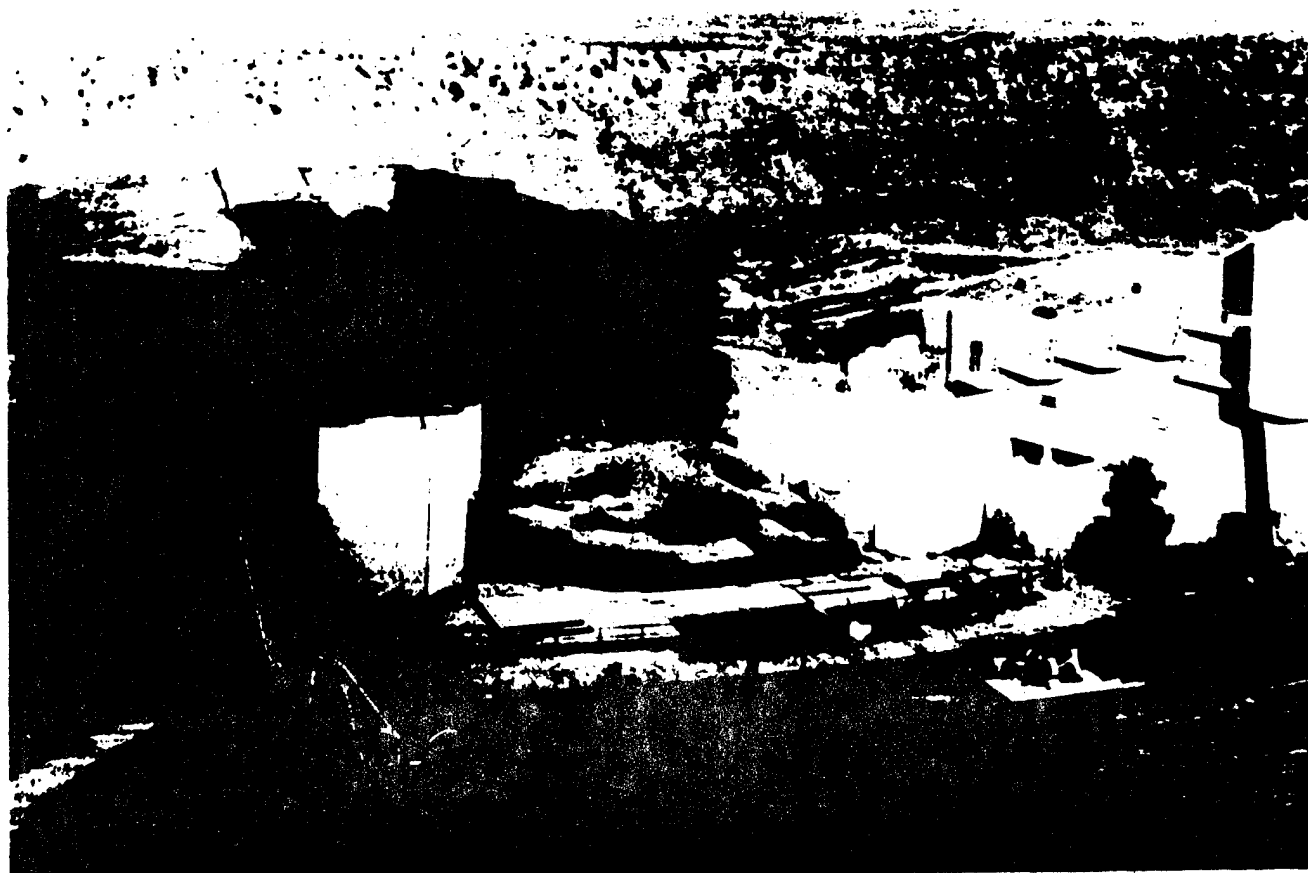

**VIEW OF THE SET FOR INITIATION. 3500 SQ FT OF INFLATED VINYL WERE USED TO CREATE THIS STAGE-ENVIRONMENT. EDGES ARE SECURED BY THE USE OF 6' LONG WATER BAGS LAID END TO END. IN THE FAR BACKGROUND IS DENVER, COLORADO. THE PHOTO WAS TAKEN FROM MID-THEATER, RED ROCKS AMPHITHEATER.**

## 5. CONCLUSION

We believe that one of the most important ideas realized in this century lies in the inventions of plastics. Yet many unique and esthetic applications of this material remain unexplored. Plastic materials are a special set--needlessly limited to the simulation of other materials. With inherent characteristics such that "impossible" shapes, structures and multidimensional forms are made possible, plastic materials provide a vast new resource which can change, expand, and evolve. The synthesis of natural materials into functionally innovative solutions arrives in an era of rapidly changing demands. The synthesis parallels a point of view. We think it can be said that Plastics offer a contemporary and future-directed perspective.

It has been our intention to use plastic esthetically, to use it literally and functionally, to pursue its limits, to involve its strengths, and to define new possibilities with it. Plastic is both a material for us and a way of thinking: infinitely flexible, transformative, conceptually free. We believe that it may have as profound an impact on history as Darwin's theory of evolution.

### DEREK BALL

Born in New Zealand, Derek Ball graduated from Auckland University. Ball was the recipient of a Frances Hodgkins Fellowship and later taught in England for two years. He came to the United States to work primarily with plastic. Fascinated by the non-material quality of plastics and its ability to take on form without space, Ball is finishing an MFA in the sculptural qualities of plastic at the San Francisco Art Institute. Derek Ball intends to remain in the USA to work out applications of plastics with

particular emphasis on low cost methods of manufacture.

### THOMAS FELDMAN

Born in New York City, Tom Feldman graduated from the University of Denver in 1972. While in Colorado he was creator, director and producer for a series of original dramatic performances which utilized conventional forms, actors and dancers, as well as multiple image projections, video production and contemporary staging techniques.

Feldman has an extensive background in media including film, newspaper, magazine, radio and television production and recently with multimedia shows. Currently he is acting as a creative consultant to several large institutions in Los Angeles.

Born London, England, 1938, Ed Pickett studied at Leicester College of Art, 1954-1958; Intermediate Diploma in Art, 1956; National Diploma in Art, 1958; Boise Travelling Award, 1958; Government Scholarship to Royal College of Art, London, 1960; graduated Associate of the Royal College of Art, 1964; exhibited RCA Galleries, 1966; "Towards Art I," 1966, "Towards Art II," 1967, at the Arts Council Galleries, England; retrospective show (in conjunction with Canadian sculptor Jerry Pethick), "Plastics," at St. Clement Hall, London, 1968; "Sculpture in the Open Air," Battersea Park, London, 1968; sculptures for "Holography," Palace of Fine Arts, San Francisco, 1970; "Environmental Sculpture," Red Rocks Amphitheater, Colorado, 1972; "Sculpture," Diego Rivera Gallery, 1973; awarded UICA Research Grant (Thermoplastic Sculpture/Structure), 1973.

Since 1968 has worked as a sculptor almost exclusively in plastics, has taught the subject in England, and since 1970 has been teaching sculpture and establishing a unique plastics research facility for artists at the San Francisco Art Institute.