

NASA Technical Memorandum 83719

(NASA-TM-83719) EVALUATION OF TWO  
POLYIMIDES AND OF AN IMPROVED LINER  
RETENTION DESIGN FOR SELF-LUBRICATING  
BUSHINGS (NASA) 17 p HC A02/MF A01 CSCL 11H

N84-27887

Unclas  
G3/27 19616

# Evaluation of Two Polyimides and of an Improved Liner Retention Design for Self-Lubricating Bushings

Harold E. Sliney  
Lewis Research Center  
Cleveland, Ohio

DTIC QUALITY INSPECTED 4



Prepared for the  
Joint Lubrication Conference  
cosponsored by the American Society of Mechanical Engineers and  
the American Society of Lubrication Engineers  
San Diego, California, October 22-24, 1984

DISTRIBUTION STATEMENT A

Approved for public release;  
Distribution Unlimited



DEPARTMENT OF DEFENSE  
PLASTICS TECHNICAL EVALUATION CENTER  
ARPA/COM, DOVER, N. J. 07801

19960229 034

PLASTIC 47538

# DISCLAIMER NOTICE



**THIS DOCUMENT IS BEST QUALITY AVAILABLE. THE COPY FURNISHED TO DTIC CONTAINED A SIGNIFICANT NUMBER OF PAGES WHICH DO NOT REPRODUCE LEGIBLY.**

EVALUATION OF TWO POLYIMIDES AND OF AN IMPROVED LINER RETENTION  
DESIGN FOR SELF-LUBRICATING BUSHINGS

Harold E. Sliny  
National Aeronautics and Space Administration  
Lewis Research Center  
Cleveland, Ohio 44135

ABSTRACT

Two different polyimide polymers were studied; in addition, the effectiveness of a design feature to improve retention of the self-lubricating composite liners under high load was evaluated. The basic bearing design consisted of a molded layer of chopped graphite-fiber-reinforced-polyimide (GFRPI) composite bonded to the bore of a steel bushing. The friction, wear, and the load carrying ability of the bushings were determined in oscillating tests at 25°, 260°, and 315° C at radial unit loads up to 260 MPa. Friction coefficients were typically 0.15 to 0.25. Bushings with liners containing a new partially fluorinated polymer were functional, but had a lower load capacity and higher wear rates than those containing a more conventional, high temperature polyimide. The liner retention design feature reduced the tendency of the liners to crack and work out of the contact zone under high oscillating loads.

INTRODUCTION

Polymer composites are an important class of bearing materials. They are frequently used without oil or grease lubrication and therefore depend upon their self-lubricating characteristics to achieve acceptable friction and wear properties. The tribological properties of many polymeric composite bearing materials have been extensively documented, e.g., Refs. 1 to 11. Of all the composites widely used in current technology, those based upon certain polyimide polymers have the highest temperature capabilities. Composites of polyimides with graphite fiber reinforcement have been shown to have promising tribological properties (1, 2, 5, 8 to 10).

E-2083

Polyimides are a family of organic polymers in which the repeating linkage is the imide group. They are formed by the polymerization of aromatic dianhydrides with aromatic diamines. The monomers from which the polyimides are synthesized have a marked influence on their properties including their thermal and oxidative stabilities. Among the polyimides with the highest temperature capabilities in tribological applications are certain partially fluorinated polyimides (3). In this program, an objective was to evaluate self-lubricating bushings to 315° C which is well above the maximum temperature capability of most polymers. Therefore two partially fluorinated polyimides were chosen for the preparation of graphite fiber reinforced polyimide (GFRPI) bushing liners. They were selected because composites of both polymers have shown good tribological properties in pin on disk studies reported by Fusaro (3 and 10).

A liner edge retention feature similar to that which Gardos (1) had found to improve the dynamic load capacity of self-lubricating bushings was also evaluated.

The scope of the present study included determination of friction, wear, and dynamic load capacities of GFRPI-lined bushings at ambient temperature, 260° and 315° C. Radial loads were 69, 138, 207, and 276 MPa (10, 20, 30, and 40 ksi). Oscillating conditions were  $\pm 25^\circ$  (100° per cycle) at 0.33 Hz (20 cpm). Test durations at each load/temperature condition were a maximum of 25 000 oscillating cycles or until the bushing failed. The dynamic load capacities of bushings with and without liner edge retention shoulders were compared.

#### BEARING DESCRIPTION

##### Design

Test bushings with and without liner edge retention shoulders are depicted in Fig. 1. They are simply metallic cylindrical outer shells with bonded composite liners. The liner length is 12.7 mm and the bore diameter is 12.73 to

12.74 mm. Journal diameters are sized to give a 0.04 to 0.05 mm (0.0015 to 0.0020 in.) diametral clearance. The outer shell is 440-c steel with a hardness of  $R_c$  27. The bushing outside diameter is 15.9 mm. For bushings without edge retention shoulders, (fig. 1(a)), the liner extends to the ends of the bushings. For bushings with edge retention shoulders (fig. 1(b)), the liner dimensions are unchanged but the overall length of the bushing is increased to 17.3 mm by the width of the two 2.3 mm thick edge retention shoulders.

#### Bearing Materials

The journals are fabricated of 17-4 PH steel heat treated to a hardness of  $R_c$  45 to 47. The O. D. surfaces are ground and buffed to a surface finish of 0.10 to 0.15  $\mu\text{m}$  (4 to 6  $\mu\text{in.}$ ) rms.

The self-lubricating liner consists of a 1:1 ratio by weight of polyimides and chopped graphite fibers. The polyimides used are both partially fluorinated condensation-type polymers. The basic structure of the two polymers are represented in Figs. 2(a) and 2(b). These polymers will be referred to throughout this paper as polyimide A and polyimide B respectively. Polyimide B is a relatively new high temperature polymer. Cure procedures for composites of this polymer are still under study and therefore may not yet be optimized.

The chopped graphite fibers used in the GFRPI bearing liners are normally 6 mm long, and consist of filaments with a diameter of  $8 \times 10^{-3}$  mm. They are prepared by the graphitization of polyacrylonitrile fiber for 10 hr at 1600° C. This yields an intermediate degree of graphitization with an imperfect graphitic crystal structure and a specific gravity of 1.76. The fibers have an elastic modulus of 255 GPa ( $37 \times 10^6$  psi) and a tensile strength of 1.90 GPa (275 000 psi).

The composite liners were transfer molded directly into the bushings. The procedures for the preparation and molding of the composite liners are described in Ref. 8.

### Bearing Test Equipment and Procedure

The bearing tester used in this program is shown in Fig. 3. The test bearing (bushing) is held with a 0.013 mm (0.0005 in.) nominal interference fit in a 17-4 PH steel housing which positions the bushing and transmits load during cycling. The test bearing is supported on each side by three large, grease-lubricated ball bearings (a total of six) mounted in fixed housings.

The bearing frictional torque is obtained from a strain gauge between the support bearings and the drive mechanism, which measures the combined frictional torque of the test and the support bearings. The torque magnitude of the support bearings remains constant and is significantly lower than the test bearing. Any change in the total torque system, therefore, is the result of frictional changes in the test bearing. The machine is instrumented to allow complete machine shutdown at predetermined torque cutoff points when failure occurs in the test bearings.

Bearing wear during cycling is monitored by a dial indicator mounted below the bushing holder, which measures changes in holder position due to wear of the bushing and/or shaft. In addition to the dial gauge wear readings, "before and after" measurements of the bores are made with a tapered bore gauge. These wear measurements cannot distinguish between wear due to material removal and to creep or plastic deformation of the bearing material. However, they do give the increase of internal clearance which is important in this type of bearing. The clearance determines bearing backlash which is a critical factor in many applications of oscillating bearings.

Loading of the test bearing is accomplished with a pneumatic loading cylinder. The cylinder is connected to the bearing holder through a lever system so that a maximum of  $1.3 \times 10^5$  N (30 000 lb) can be applied to the test bearing. The shaft is crank driven by a motor and gearbox unit. In this program, the shaft oscillated  $\pm 25^\circ$  at 20 cpm.

The test bearing and shaft are heated with resistance heaters. A thermocouple is tack-welded to the edge of the test bearing housing as close as possible to the bearing.

## EXPERIMENTAL RESULTS AND DISCUSSION

### Wear and Friction

The liner wear usually followed a consistent pattern with test duration. A schematic of a typical wear-time (expressed as accumulated oscillating cycles) profile is given of Fig. 4. The profile characteristically has three major regimes: run-in, steady state, and accelerated wear (after the liner fails). Wear is expressed as radial wear which, during run-in, is a combination of liner deformation and material loss; steady state wear is true volumetric wear caused almost exclusively by loss of liner material from the load zone, and accelerated wear includes wear of the journal on the metallic bearing shell after liner failure.

Figures 5 to 7 are wear and friction coefficient profiles obtained during the bushing tests; radial wear and friction force were continuously recorded during the test.

### Bushings Without Liner Edge Retention, Fig. 1(a)

Liners of polyimide A composites. Figure 5(a) illustrates the effect of radial load at ambient temperature. At 69 MPa (10 000 psi) and 138 MPa (20 000 psi), the bushings functioned very well for the full 25 000 oscillating cycles with a steady state friction coefficient of 0.2 and no detectable wear after a brief period of mild run-in wear. At 207 MPa (30 000 psi), the liner survived 25 000 oscillating cycles, but had cracked and chipped early in the test as indicated by a very high wear rate during run-in. At 276 MPa, (40 000 psi) severe fracturing of the liner occurred at 8000 cycles followed by severe accelerated wear and a marked increase in friction coefficient. Steady state friction coefficients were unaffected by load.

Analogous data at bushing temperatures of 260° C and 315° C are given on Figs. 5(b) and 5(c). Low steady state wear and a friction coefficient of about 0.1 were observed at 260° C and a 69 MPa radial load. The liner was in good condition after the 25 000 oscillating cycles. However for loads of 138 and 207 MPa, liner failure occurred after about 7000 oscillating cycles. The liners were extensively cracked with much chipping at the bearing edges. At 315° C, the friction coefficient was initially 0.2 during a brief run-in, but the steady state friction coefficient was 0.1 or less. Failure occurred by cracking and edge chipping of the liner after 8000 cycles at 69 MPa.

In summary, the dynamic load capacities of these bushings without edge retention are about 138 MPa at room temperature, between 69 MPa and 138 MPa at 260° C, and less than 69 MPa at 315° C. In all cases, liner failure occurred because of edge chipping and crack propagation in the liner, followed by liner material being extruded out of the ends of the bearing.

These results strongly suggested that the design modification to provide liner edge retention should improve load capacity. This concept was evaluated in the bushing tests described below.

#### Bushings with Liner Edge Retention, Fig. 1(b)

A simple modification in bushing design shown on Fig. 1(b) was made. The metallic outer rings were machined to provide 0.3 mm high shoulders at both ends of the bearing bore. With a 0.5 mm liner thickness, 0.2 mm (0.008 in) of radial wear is required before the journal contacts the metal shoulder. Although the shoulders do not support the top 0.2 mm of the liner, they provide lateral restraint where it is most needed, at the bonded interface of the composite liner and the metallic outer ring.

Composite liners containing the two different polyimides were evaluated in the bushings with edge retention shoulders.

Bushings with liners containing polyimide A. The composite liners and the test procedures were identical to those used for the bearings without edge retention. The only variable was the addition of edge retention shoulders.

Figure 6(a) illustrates the effect of radial load at ambient temperature on bushings with this modification. No liner failure occurred in 25 000 oscillating cycles at 69, 138, or 207 MPa.

At 260° C (fig. 6(b)) no liner failure occurred at 69 or 138 MPa, but higher loads were not employed because the liner wore to the retaining shoulder after 25 000 cycles at 138 MPa. At 138 MPa steady state friction coefficients were 0.20 to 0.25. At 315° C (fig. 6(c)), the liner was intact after 25 000 cycles at 69 MPa but again the liner was worn to the retaining shoulder. The steady state friction coefficient was about 0.26.

The liner retention feature clearly increased the load capacity of the bushings. Liner fracture and edge chipping which caused failure of the unmodified bushings was absent in bushings with edge retention shoulders.

However, friction coefficients tended to be higher and more erratic at 260° C and 315° C than in the case of the unmodified bushings.

Bushings with composite liners containing PFPI polyimide B (fig. 1(b)).

Figure 7(a) shows the results of room temperature tests. Liner edge retainers were effective in preventing liner edge chipping and cracking but at 138 and 207 MPa, the liners wore down to the retaining shoulder in less than 25 000 cycles. At 260° C, the bushings survived 25 000 cycles at 69 and 188 MPa. Only 0.05 mm of radial wear occurred in 25 000 cycles at 69 MPa, but at 138 MPa the liner was worn 0.2 mm to the metallic shoulder after 25 000 oscillating cycles. At 315° C and 169 MPa the liner was intact but worn to the level of the retaining shoulder after 25 000 cycles. The friction coefficient rose steadily from 0.2 early in the test to 0.3 after 25 000 cycles.

In summary, the liner edge retention shoulders were effective in increasing the load capacity of the bushings by inhibiting fracture of the relatively brittle polyimide composites. However, composites of polyimide A had higher friction coefficients at 260° C and 315° C in bushings with edge restraint than in the unmodified bushings. This can be attributed to the high thermal expansion coefficient of the composite which tends to reduce bearing clearance at elevated temperatures. On the average, friction coefficients for composites of polyimide B were higher than for composites of polyimide A in room temperature tests but were about the same at 260° C and 315° C.

#### CONCLUDING REMARKS

In this program to evaluate the performance of bushings (plain cylindrical bearings) with chopped graphite fiber reinforced polyimide (GFRPI) composite liners, the following were observed:

1. Composite liners of two different partially fluorinated polyimides showed promise as self-lubricating materials for use to at least 315° C. Friction coefficients were typically in the range of 0.15 to 0.25. Load carrying ability was comparable for both compositions for short durations. However, time to failure was consistently of shorter duration for one of the polyimides which is a recently developed material for which cure procedures have not yet been fully optimized.
2. The use of liner edge retention shoulders at both ends of the metallic outer shells of the bushings improved their dynamic load capacity. The increases in load capacities for the better liner composition were from 138 MPa (20 000) to 207 MPa (30 000 psi) at room temperature, from 69 MPa (10 000 psi) to 138 MPa (20 000 psi) at 260° C, and from less than 69 MPa (10 000 psi) to 69 MPa at 315° C.
3. The mode of failure for bushing liners without edge retention was chipping and crack initiation at the edge of the liner followed by inward crack

propagation, and finally gross fracture of the composite liner. On the other hand, for bushings with edge retention, failure occurred only when the liner wore down to the metal edge retention shoulder resulting in metal/metal contact and high bearing torque. In that failure mode, load limit is more a function of an arbitrary maximum acceptable wear rate than of liner integrity, at least up to a load of 276 MPa (30 000 psi).

#### ACKNOWLEDGEMENT

The bearing tests were performed at the North American Division of Rockwell International under the direction of Mr. Frank Williams.

#### REFERENCES

1. Gardos, M. N. and Mc Connell, B. D., "Development of High-Load, High Temperature, Self-Lubricating Composites," ASLE Pre Print No. 81-LC-3A, Pts. I-IV (1981).
2. Bartenev, G. M., Lavrentev, V. V., Friction and Wear of Polymers, Elsevier, N. Y., (1981).
3. Fusaro, R. L., "Polyimides Formulated from a Partially Fluorinated Diamine for Aerospace Tribological Application," NASA TM-83339 (1983).
4. Lancaster, J. K., "Friction and Wear," Chapter 4, Polymer Science, North-Holland Publ. Co., Amsterdam (1972), Ed. Jenkins, A. D., pp. 251-321.
5. Lancaster, J. K., "Dry Bearings: A Survey of Materials and Factors Affecting Their Performance," Tribol., 6, 6, pp. 219-251 (1973).
6. Theberge, J. E., and Arkles, B., "Wear Characteristics of Carbon Fiber Reinforced Thermoplastics," Lubr. Eng. 30, 12, pp. 585-589 (1974).
7. Wolverson, M. P. Theberge, J. E., and Mc Cadden, K. L., "How Plastic Composites Wear at High Temperatures," Mach. Des. 55, 3, pp. 111-115 (1983).
8. Sliney, H. E., "Some Load Limits and Self-Lubricating Properties of Plain Spherical Bearings with Molded Graphite Fiber-Reinforced Polyimide Liners to 320° C.," Lubr. Eng., 35, 9, pp 497-507 (1979).

9. Fusaro, R. L., and Sliney, H. E., "Friction and Wear Behavior of Graphite Fiber Reinforced Polyimide Composites," ASLE Trans. 21, 4, pp 337-343 (1978).
10. Sliney, H. E., and Jacobson, T. P., "Graphite Fiber Reinforced Polyimide Liners of Various Compositions in Plain Spherical Bearings," Proceedings of the 2nd Int. Conf. on Solid Lubrication, American Society of Lubrication Engineers, Park Ridge, IL (1978), pp. 258-267.
11. Sliney, H. E., and William, Frank J., "Performance of PTFE-liner Composite Journal Bearings" Lubr. Eng., 39, 8, pp 511-518 (1983).

ORIGINAL QUALITY  
OF POOR QUALITY

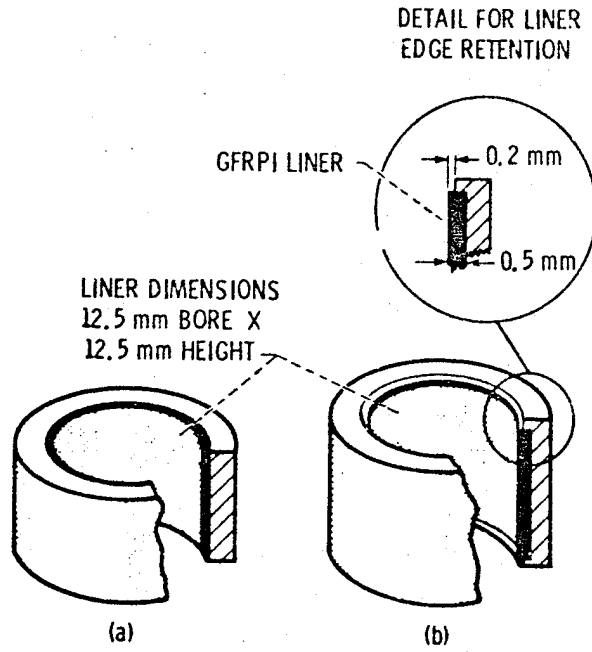

Figure 1. - Test bushings with self-lubricating liners of graphite fiber reinforced polyimide.

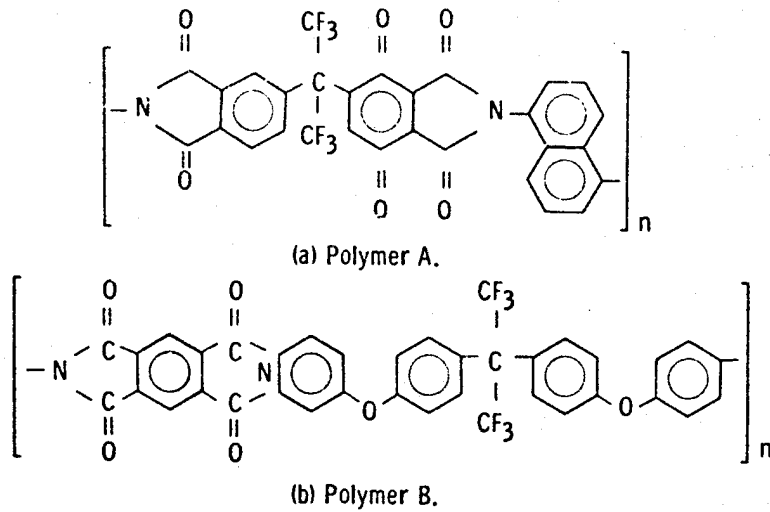

Figure 2. - Molecular structures of polyimides used in composite liners for self-lubricating test bushings.

ORIGINAL PAGE IS  
OF POOR QUALITY

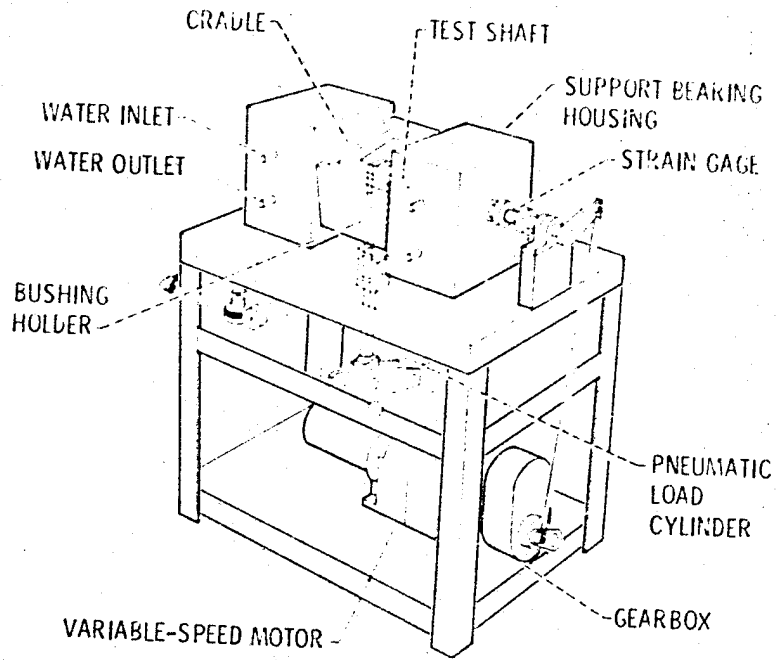

Figure 3. - Plain bearing tester.

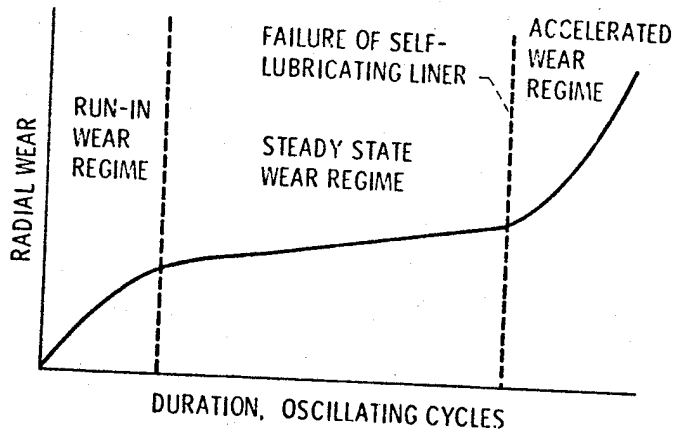

Figure 4. - Typical wear profile of bushings with self-lubricating liners.

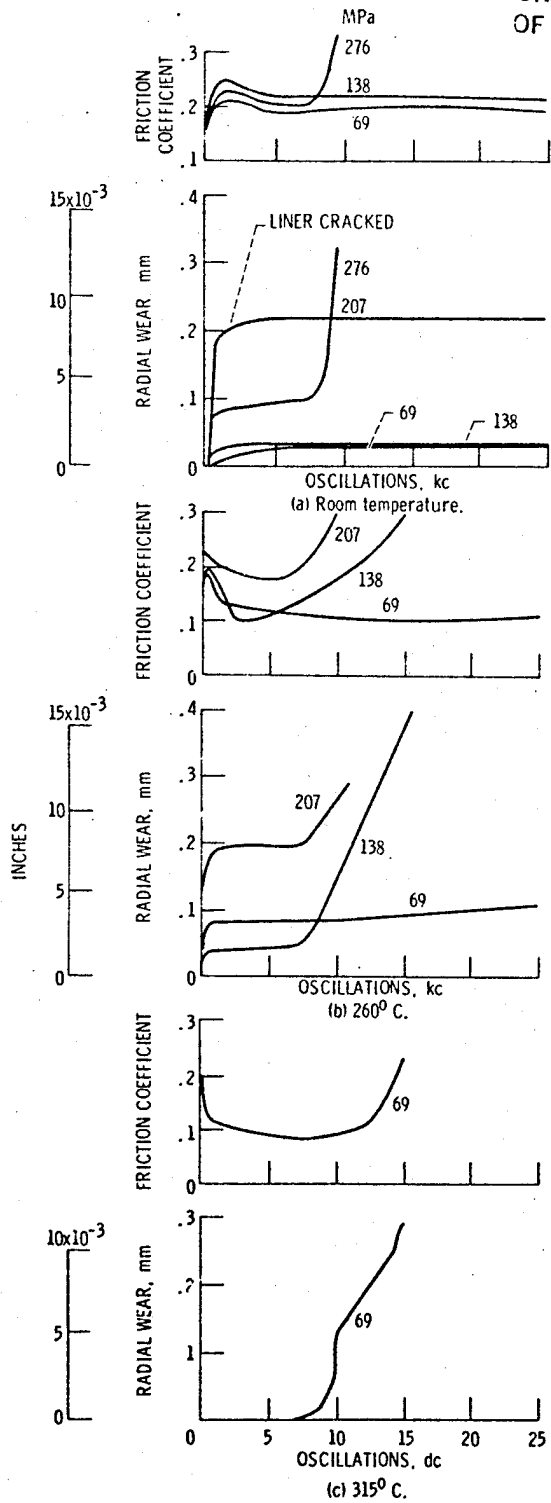

Figure 5. - Bushings without liner edge retention, polyimide A composite liner, 20 CPM, +25° to -25° oscillating 17-4 PH journal.

ORIGINAL PAGE IS  
OF POOR QUALITY

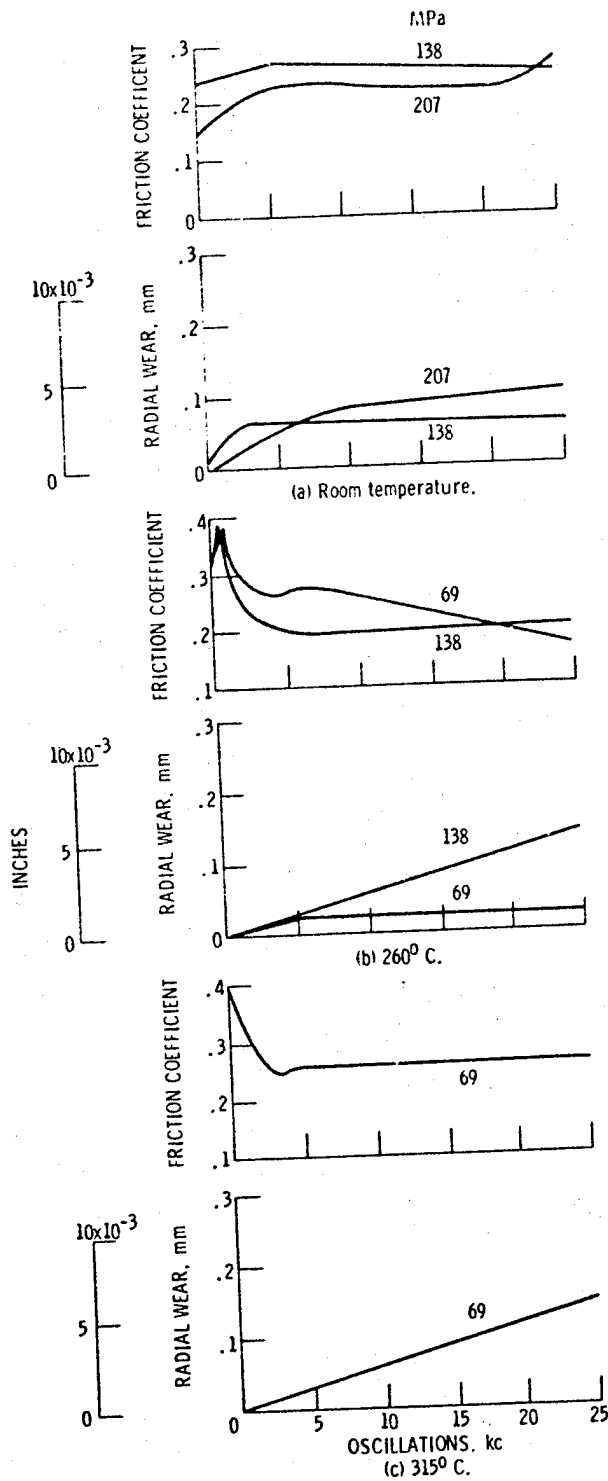

Figure 6. - Bushings with liner edge retention, polyimide A composite liner, 20 cpm + 25° to -25° oscillating 17-4 PH journal.

BY AIR MAIL

ORIGINAL PAGE IS  
OF POOR QUALITY

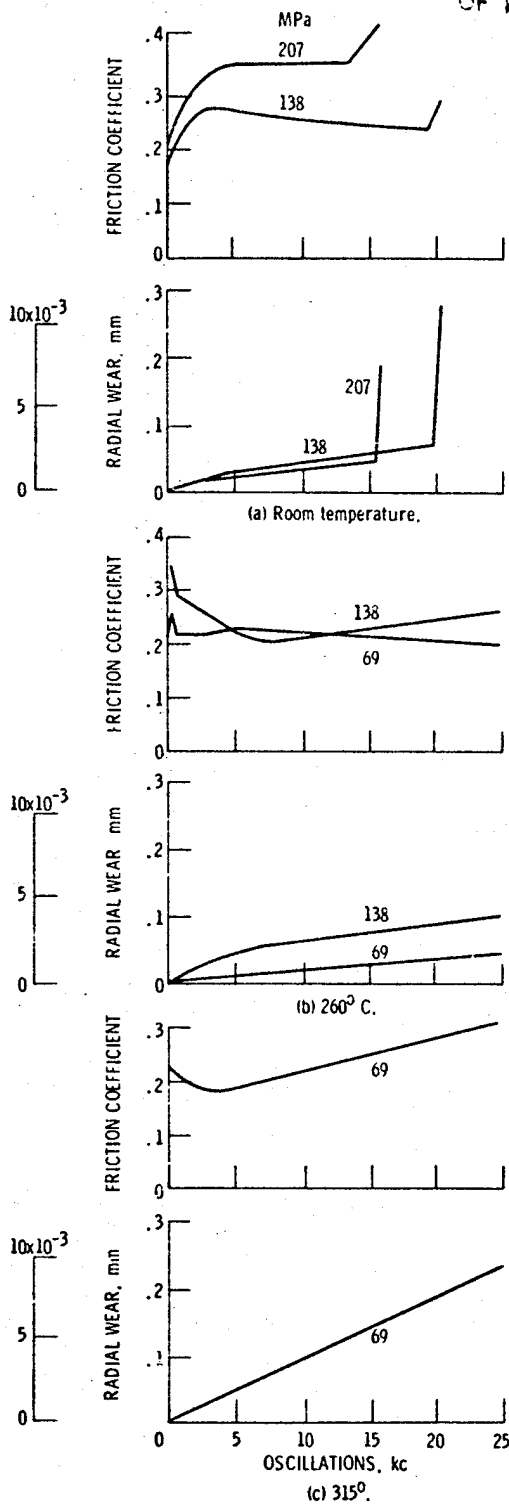

Figure 7. - Bushings with liner edge retention, polyimide B composite liner 20 cpm, +25° to -25° oscillating 17-4 ph journal.