



HARVARD COLLEGE OBSERVATORY

60 Garden Street, Cambridge, MA 02138

Sesquicentennial Year 1989

FINAL TECHNICAL REPORT NAGW-2570

Title of Investigation: *Absolute Radiometric Calibration of Solar
Extreme Ultraviolet Spectrometers*

Principal Investigator: W. H. Parkinson
Harvard College Observatory
60 Garden Street, MS-50
Cambridge, MA 02138
617/495-4865 (fax -7455)

Co-Investigator & Project Scientist: Peter L. Smith, Harvard College Observatory
Other Co-Investigators: L. D. Gardner, Smithsonian Astrophysical Observatory
J. L. Kohl, Smithsonian Astrophysical Observatory
J. A. R. Samson, University of Nebraska

Duration: 06/01/91 - 05/31/94

DISTRIBUTION STATEMENT A

Approved for public release;
Distribution Unlimited

19960311 077

Absolute Radiometric Calibration of Solar Extreme Ultraviolet Spectrometers

1. INTRODUCTION

Accurate solar extreme ultraviolet (EUV) spectral irradiance data are needed for research in solar, ionospheric/thermospheric, and planetary physics, as well as for space weather forecasts and spacecraft operations and tracking. Because of instrument performance degradation, in-orbit radiometric recalibration methods and capability are a fundamental prerequisite for such measurements. In this laboratory research program, we studied methods for in-orbit radiometric intercomparisons and calibration, and collaborated in the radiometric calibration of the Ultraviolet Coronagraph Spectrometer (UVCS) now observing the solar corona from the ESA/NASA SOHO mission.

2. METHODS FOR IN-ORBIT RADIOMETRIC CALIBRATION

There are two complementary methods for EUV radiometric calibration: one uses a standard source of spectral radiance; the other, an absolute detector. Each method has advantages and disadvantages; they cover somewhat different wavelength ranges and there are different calibration points within each range.

2.1 The 'Standard' Source of EUV Spectral Radiance

A hollow cathode EUV spectral radiance transfer standard that is small and rugged has been evaluated, characterized, and calibrated using the BESSY synchrotron radiation source by a team of scientists from the Physikalisch-Technische Bundesanstalt (PTB) and the University of Hannover (Danzmann *et al.* 1988). We refer to this as the PTB BESSY/Hannover (PBH) EUV source. The emission consists of many lines, mostly the resonance lines of neutral, singly, or doubly ionized rare-gas atoms. About 50 lines, roughly evenly separated in the wavelength range 20 to 150 nm, are unblended and, therefore, have been selected for radiometric calibration purposes (Hollandt, Kühne, Huber & Wende 1996). The spectral range of the Solar Ultraviolet Measurements of Emitted Radiation (SUMER) and UVCS SOHO instruments can be completely covered with strong lines emitted by the source. We constructed and evaluated a low-power version of the PBH source in order to determine whether it would be suitable for in-flight radiometric calibrations.

The PBH spectral radiance standard hollow cathode is commercially available in uncalibrated form from Prof. M. Kock at the University of Hannover. Calibration of the source is performed on a 'commercial' basis by the PTB Radiometry Laboratory at BESSY (Hollandt, Kühne & Wende 1994) using facilities developed, in part, in collaboration with the SOHO mission. As part of radiometric calibrations of the SOHO spectroscopic instruments, the BESSY Radiometry Laboratory calibrated combinations of the PBH EUV source coupled with a 1-m focal-length, $f/100$, collimating mirror. Spectral-line flux values per cm^2 , comparable to solar line irradiances at 1 AU when integrated over the ~ 1 cm diameter of the collimated beam, were provided.

With funds from this grant, we obtained two spectral radiance sources from Prof. Kock and two mirrors from the PTB/BESSY Radiometry Lab. One source/mirror combination was delivered to us in August 1991 and was used 'as is' in the apparatus described in Sect 2.3. The second was calibrated in July 1993 at BESSY in collaboration with the SUMER/SOHO calibration activities and delivered to us in the Fall of 1993 to be used for illumination of UVCS in the intercomparison of its radiometric scale with that of SUMER. The uncalibrated system was used for alignment, signal level checks, and optimization.

2.2 Standard Detector for EUV Radiation

Rare-gas ionization chambers, or Samson chambers (Samson 1967), make use of the fact that incident photons produce a known number of ions when they pass through an optically thick sample of gas. For the rare gases, this 'quantum yield' per photon is 1.0, *i.e.*, one photon produces one electron. Ionization chambers are so well-characterized that they are the basis for routine calibrations of the photodiode 'standard' EUV detectors provide by NIST and, therefore, have potential for use in on-orbit radiometric calibration of spectrometers.

We determined the wavelength band and sensitivity that would be available from selected combinations of rare gases and the thin metal film filters that are used to constrain the gas. The ionization cross sections and

transmission data were available from the scientific literature and from trade catalogues. One result of our study was that the concept could work but that the availability (Spring 1994) of space-qualified thin film filters that could be used to define a number of distant wavelength bands had not been verified: for example, we learned from the EUVE Electronic Newsletter of April 12, 1994, that very small pinholes may develop in these filters.

2.3 Laboratory Set-up for Evaluation of Standard Source and Detector

We constructed the apparatus shown schematically in Fig. 1 for our laboratory evaluation and intercomparison of the two complementary methods for in-orbit radiometric calibration of instruments for measuring the full-disk, spectrally-resolved solar EUV flux from 10 to 125 nm. The three major components are shown: a calibrated-source/mirror combination, an ionization-chamber/filter mechanism, and a spectrometer.

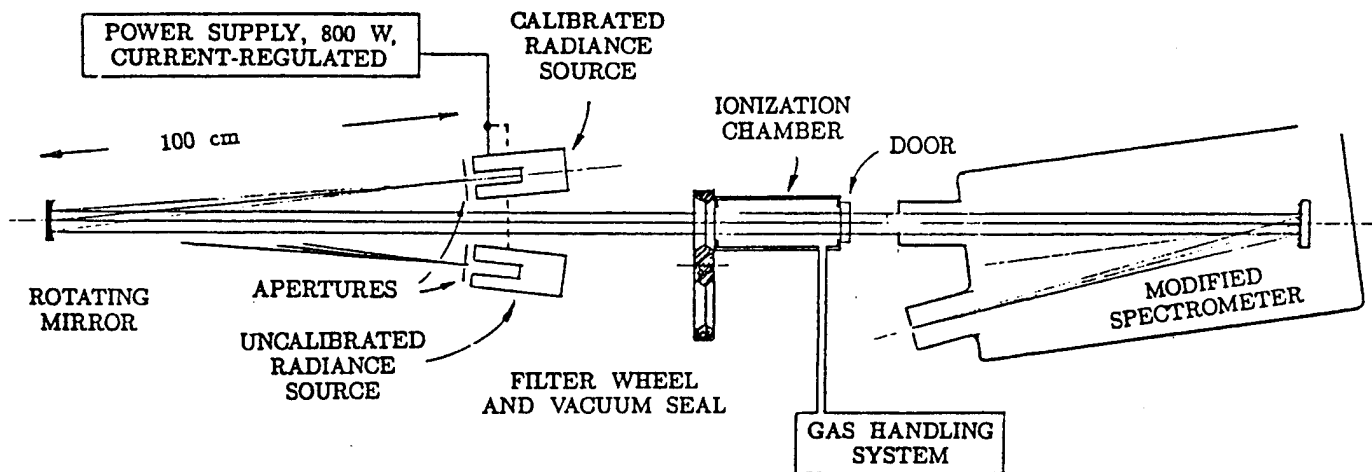

Figure 1. Schematic diagram of laboratory set-up. The diagram is approximately to scale, but the beam diameter, which is actually about 1 cm, has been enlarged for clarity. The spectral radiance sources, mirror, and filter wheel are all enclosed in a vacuum chamber. The bias voltage supplies and current measuring apparatus for the ionization chamber and the photon-counting detector for the spectrometer have been omitted. The spectrometer modifications resulted in the equivalent of a Wadsworth-mount spectrograph, with the optical aperture of the spectral radiance standard serving as the entrance slit.

3. CALIBRATION

The calibration and characterization of the radiance standard were completed in July 1993. The wavelength range was 50 - 130 nm. As a result of some changes in the characterization, modifications were made in our calibration set-up. The PBH EUV source was used here in 1995 in the final end-to-end test of the UVCS¹ instrument (Kohl *et al.* 1995).

4. OTHER RELATED ACTIVITIES

We participated with Drs. Jay Holberg and Bill Sandel of the Lunar & Planetary Laboratory at the University of Arizona, in exploring the idea of using the ultraviolet Wadsworth-mounted ultraviolet spectrometers (UVS) on the Voyager Spacecraft for solar EUV radiometry. These spectrometers have been radiometrically stable for some time and are therefore capable of making long-term, precise measurements of the solar spectral irradiance between 50 and 170 nm. If the detection efficiencies of the UVS were confirmed through

¹At the time of writing this report, the SOHO had been placed in orbit and UVCS had successfully seen "first light" in both the Ly- α and OVI channels.

a dedicated program of underflights, and if a campaign of regular Voyager observations of the Sun were instituted, some of the needs for timely, long-term solar EUV flux data could have been efficiently met in this decade. The motivation for and findings of this study were presented at two radiometry meetings: (1), The Fourth International Meeting on New Developments and Applications in Optical Radiometry, Baltimore, MD, October 1992, and, (2), The Ninth Workshop on the Vacuum Ultraviolet Calibration of Space Experiments, Boulder, CO, March 1993. The references to the resulting publications are in Sect. 5.

In 1991, Smith served on the NASA Science Working Group (SWG) for SOURCE. The SWG reaffirmed the need for in-flight calibration methods for solar EUV spectral radiometers and included our concept for on-board 'standard' radiance sources and rare-gas ionization cells in the 'strawman' payload. Smith represented the SOURCE SWG at the two radiometry meetings mentioned above and presented a paper on SOURCE at both.

5. PUBLICATIONS

SOURCE: The Solar Ultraviolet Radiation and Correlative Emissions Mission, P. L. Smith, J. L. Lean, A. B. Christensen, K. L. Harvey, D. L. Judge, R. L. Moore, M. R. Torr & T. N. Woods, *Metrologia* **30**, 275-277 (1993). Also see P. L. Smith *et al.*, The Ninth Workshop on Vacuum Ultraviolet Calibration of Space Experiments, ed. T. N. Woods [Boulder, CO: NCAR].

Using the Voyager Spacecraft for Solar EUV Spectral Radiometry, P. L. Smith, B. R. Sandel & J. B. Holberg, *Metrologia* **30**, 397-401 (1993); invited paper. Also see P. L. Smith *et al.*, The Ninth Workshop on Vacuum Ultraviolet Calibration of Space Experiments, ed. T. N. Woods [Boulder, CO: NCAR].

Absolute, Extreme-Ultraviolet Solar Spectral Irradiance Monitor (AEISSIM), W. H. Parkinson, P. L. Smith & G. Schmidtke, Proc. Workshop on the Solar Electromagnetic Radiation Study for Solar Cycle 22, ed. R. F. Donnelly, [Boulder: U.S. Dept. of Commerce Environmental Research Laboratories], pp. 332-337 (1992).

Absolute, Extreme-Ultraviolet Solar Spectral Irradiance Monitor (AEISSIM), W. H. Parkinson, P. L. Smith & G. Schmidtke, U.S.-Taiwan Bilateral Workshop on Solar Variability Effects on the Atmosphere and Space Processing; invited paper, (1991).

In-Orbit, EUV Radiometric Calibration of Satellite Instrumentation, P. L. Smith, M. C. E. Huber, W. H. Parkinson, M. Kühne & M. Kock, in *Extreme Ultraviolet Astronomy*, ed. R. F. Malina & C. S. Bowyer [New York: Pergamon], pp. 390-394 (1991).

6. REFERENCES

Danzmann, K., M. Guenther, J. Fisher, M. Kock & M. Kühne 1988, *The High Hollow Cathode as a Radiometric Transfer Source for the Extreme Vacuum Ultraviolet*, *Appl. Opt.* **27**, 4947.

Hollandt, J., M. Kühne, M. C. E. Huber & B. Wende 1996, private communication.

Hollandt, J., M. Kühne & B. Wende 1994, *High-Current Hollow-Cathode Source as a Radiant Intensity Standard in the 40-125-nm Wavelength Range*, *Appl. Opt.* **33**(1), 68.

Samson, J. A. R. 1967, *Techniques of Vacuum Ultraviolet Spectroscopy*, pp. 265.