

BDX-613-2407

Simultaneous Measurement of Multilayered Composites

By R. V. Heckman

Published June 1980

Milestone Report

19960307 010

DISTRIBUTION STATEMENT A
Approved for public release;
Distribution Unlimited

Prepared for the United States Department of Energy
Under Contract Number DE-AC04-76-DP00613.



**Kansas City
Division**

DTIC QUALITY INSPECTED 1

PLASTIC
391779

This report was prepared as an account of work sponsored by the United States Government. Neither the United States nor the United States Department of Energy, nor any of their employees, nor any of their contractors, subcontractors, or their employees, makes any warranty, express or implied, or assumes any legal liability or responsibility for the accuracy, completeness or usefulness of any information, apparatus, product or process disclosed, or represents that its use would not infringe privately owned rights.

Printed in the United States of America

Available From the National Technical Information Service, U.S. Department of Commerce, 5285 Port Royal Road, Springfield, Virginia 22161.

Price: Microfiche \$3.00
Paper Copy \$4.50

BDX-613-2407
Distribution Category UC-38

SIMULTANEOUS MEASUREMENT
OF MULTILAYERED COMPOSITES

By R. V. Heckman

Published June 1980

Milestone Report

Technical Communications



**Kansas City
Division**

SIMULTANEOUS MEASUREMENT OF MULTILAYERED COMPOSITES

BDX-613-2407, Milestone Report, Published June 1980.

Prepared by R. V. Heckman

A theoretical treatment of the eddy current problem involving a two-layered conductor laminate is presented for a rectangular cross section coil, with experimental eddy current measurements indicating that a frequency of 1.5 MHz should be used to measure a 6.45 μm aluminum conductor, a 0.5 MHz frequency should be used to measure a 50.8 μm aluminum conductor, and a frequency of 30 MHz should be used to measure lift-off. The schematic and the basic design of a two-frequency microprocessor controlled eddy current system is also presented.

DC/djb

This report was prepared as an account of work sponsored by the United States Government. Neither the United States, nor the United States Department of Energy, nor any of their employees, nor any of their contractors, subcontractors, or their employees, makes any warranty, expressed or implied or assumes any legal liability or responsibility for the accuracy, completeness or usefulness of any information, apparatus, product, or process disclosed, or represents that its use would not infringe privately owned rights.

**The Bendix Corporation
Kansas City Division
P. O. Box 1159
Kansas City, Missouri 64141**

A prime contractor with the United States
Department of Energy under Contract Number
DE-AC04-76-DP00613

CONTENTS

Section	Page
SUMMARY.	6
DISCUSSION	7
SCOPE AND PURPOSE.	7
PRIOR WORK	8
ACTIVITY	8
<u>Theoretical Aspect of the Multilayered</u> <u>Eddy Current Problem</u>	8
<u>The Two-Conductor Problem for Delta Coils</u> <u>and Rectangular Cross Section Coils.</u>	9
<u>Experimental Measurements.</u>	20
<u>System Construction.</u>	22
ACCOMPLISHMENTS.	22
FUTURE WORK.	23
SYMBOL TABLE	34
REFERENCES	36

ILLUSTRATIONS

Figure		Page
1	A Delta Function Coil Above a Two-Conductor Plane.	10
2	A Coil of Rectangular Cross Section Above a Two-Conductor Plane.	13
3	Lift-Off Determination at 3.2 MHz, Kapton on 0.25 Mil Aluminum	26
4	Lift-Off Determination at 32 MHz, Kapton on 0.25 Mil Aluminum	27
5	Lift-Off Determination at 3.2 MHz, Kapton on 2 Mil Aluminum.	28
6	Lift-Off Determination at 32 MHz, Kapton on 2 Mil Aluminum.	29
7	Variation of Coil Resistance With Lift-Off at 3 MHz (Calculated Russian Expression) . .	30
8	Variation of Coil Resistance With Lift-Off at 30 MHz (Calculated Russian Expression) . . .	31
9	Schematic of a Two-Frequency Eddy Current System	32
10	Block Diagram of the NDT Microcomputer Designed by ORNL	33

TABLES

Number		Page
1	Physical and Electrical Properties of the Pancake Coils (Planer Coils)	21
2	Sensitivity of Phase and Amplitude for Aluminum in the 3.76 to 6.45 μm Range at Various Frequencies Using Probe C.	22
3	Sensitivity of Phase and Amplitude for Aluminum in the 46.74 to 51.82 μm Range for Various Frequencies Using Probe C.	23
4	Sensitivity of Phase and Amplitude for Aluminum in the 46.74 to 51.82 μm Range for Various Frequencies Using Probe B.	24
5	Sensitivity of Phase and Amplitude for Aluminum in the 24.4 to 127.0 μm Range at Various Frequencies Using Probe C.	25

SUMMARY

The simultaneous measurement of multilayered composite materials is a reoccurring problem. At present, Bendix Kansas City does not have a nondestructive method capable of measuring the thickness and conductivity of the individual layers of a composite consisting of conductors and nonconductors. Multi-frequency eddy current techniques offer the potential of being able to provide such a nondestructive test.

This project is investigating both the theoretical and experimental aspects of this problem. This particular report presents a theoretical solution to the two-layered and n-layered flat laminar composite materials. In addition, the results of some preliminary experimental measurements and the basic system design of a two-frequency eddy current system is discussed. The results of this theoretical and experimental work will be used in modeling the particular composite structures of interest.

DISCUSSION

SCOPE AND PURPOSE

The overall objective of this project is to develop nondestructive testing techniques to measure the physical characteristics of the individual layers of composite materials. This report will deal primarily with the theoretical aspects of multi-frequency eddy current techniques. A derivation of the vector potential for a two-layered conductor as well as for the general multi-layered conductor problems will be presented. The report will also give the technical specifications for the two-frequency eddy current system that is being built together with the schematic and design details of the microprocessor that will be used in the system to perform data reduction and control the measurement process. Later reports will deal with the subjects of energy dependent beta-backscatter and optical reflection methods using a light-section microscope. Concurrent with these development activities a literature search is being conducted and other appropriate nondestructive testing techniques will be evaluated as they are discovered.

Although eddy current testing is not a new technique, the use of multiple frequencies is a relatively new application. The mathematics of the technique are so complex that only with the advent of the microprocessor has extensive use of the technique been feasible. The developments presented and the basic instrumentation being built is based on the work performed primarily at Oak Ridge National Laboratory (ORNL), and Lawrence Livermore Laboratories (LLL).

The composite structures of interest are primarily multi-layered structures made of aluminum and Kapton. One structure of interest consists of a 0.203-mm-top kapton layer over a 0.050-mm-aluminum conductor. These two layers are then bonded to a 0.305-mm-kapton base with a 0.127-mm-copper back plane. The other composite of interest consists of a 0.051-mm-top kapton layer, a 0.0127-mm-physical vapor deposited aluminum conductor, a 0.203-mm-kapton layer, and a 0.127-mm-aluminum back plane. In both of these structures the ultimate goal is to determine the thickness of each insulator and conductor, and to simultaneously measure the conductivity of the aluminum components. In addition to these two laminates, several other structures are being considered but the initial development activity will be targeted at the above materials.

PRIOR WORK

Prior work has been performed relating to measurement techniques for aluminum thickness. Most of this work centered around the development of beta-backscatter techniques.¹

In a sense, this project is a continuation of that activity; however, the purpose is to extend the measurement capability to enable measurement of multiple layers simultaneously.

ACTIVITY

Theoretical Aspect of the Multilayered Eddy Current Problem

Eddy currents have been recognized for well over 100 years. As early as 1879 D. E. Hughes used induction coils to sort metals.² Numerous articles were written on the subject. The earliest reports dealing with both the theory and practical aspects are by Forster in the early 1950's.³⁻⁵ Hochschile, Waidelich, and Renken also were early contributors to the theory of eddy currents. In 1962 Vein⁷ and in 1964 Cheng and Burrows²⁻⁹ gave treatments based on delta function coils. In 1963 C. V. Dodd and D. A. Deeds¹⁰ developed a relaxation theory to calculate the vector potential of a coil with a finite cross section. The primary drawback of the relaxation technique is the extreme amount of computer memory and time required for computation. In 1967, Victor Sergeevich Sobolev, Yurii Mikahilovich Shkarlet,¹¹ developed a set of integral equations for the vector potential. In 1969 Dodd, Deeds et al¹² developed a similar set of integral equations. In the case of the Russian authors, they developed approximate solutions to these equations using tabled integrals whereas Dodd and Deeds developed computer programs to evaluate these equations using a small computer. Later in 1971, Dodd, Cheng, and Deeds produced a general analysis of the eddy current problem of stratified conductors. From this general analysis Dodd, and others have developed a vast library of interactive computer programs that allow optimization of probe parameters and accurate predictions of the experimental values of amplitude and phase.¹³

In this report, the development of the closed end integral equations originally derived by Dodd and Deeds for the two-layer conductor case will be presented with the equations for the general n-layered conductor case.

The Two-Conductor Problem for Delta Coils and Rectangular Cross Section Coils

Using Bruce Maxwell's (LLL) equations, and assuming that the medium is linear and isotropic but not homogeneous, that the vector potential has axial symmetry, and that the current density (J_0) is a sinusoidal function of time ($J_0 = J_0^1 e^{j\omega t}$), then it can be shown that the vector potential A for a delta function coil must satisfy the equation:

$$\frac{\partial^2 A}{\partial r^2} + \frac{1}{r} \frac{\partial A}{\partial r} + \frac{\partial^2 A}{\partial z^2} - \frac{A}{r^2} = -\mu J_0 + j\omega\mu\sigma A \quad (1)$$

$$- \mu \frac{\partial(1/\mu)}{\partial r} \frac{1}{r} \frac{\partial r A}{\partial r} + \frac{\partial(1/\mu)}{\partial z} \frac{\partial A}{\partial z}$$

When I is the total driving current in a delta function coil at (r_0, Z_0) , Equation 1 then becomes:

$$\frac{\partial^2 A}{\partial r^2} + \frac{1}{r} \frac{\partial A}{\partial r} + \frac{\partial^2 A}{\partial z^2} - \frac{A}{r^2} - j\omega\mu\sigma A + \mu I \delta(r - r_0) \delta(Z - Z_0) = 0 \quad (2)$$

For the special case of a two-conductor plane, Equation 2 for each of the four regions shown in Figure 1 can be written as:

$$\frac{\partial^2 A}{\partial r^2} + \frac{1}{r} \frac{\partial A}{\partial r} + \frac{\partial^2 A}{\partial z^2} - \frac{A}{r^2} = 0 \text{ Regions I and II} \quad (3)$$

$$\frac{\partial^2 A}{\partial r^2} + \frac{1}{r} \frac{\partial A}{\partial r} + \frac{\partial^2 A}{\partial z^2} - \frac{A}{r^2} - j\omega\sigma_i A = 0 \text{ Regions III and IV} \quad (4)$$

These equations can be solved by the separation of variables technique and by then evaluating the following boundary conditions for the different regions, namely:

$$A^{(1)}(r, \ell) = A^{(2)}(r, \ell) \quad (5)$$

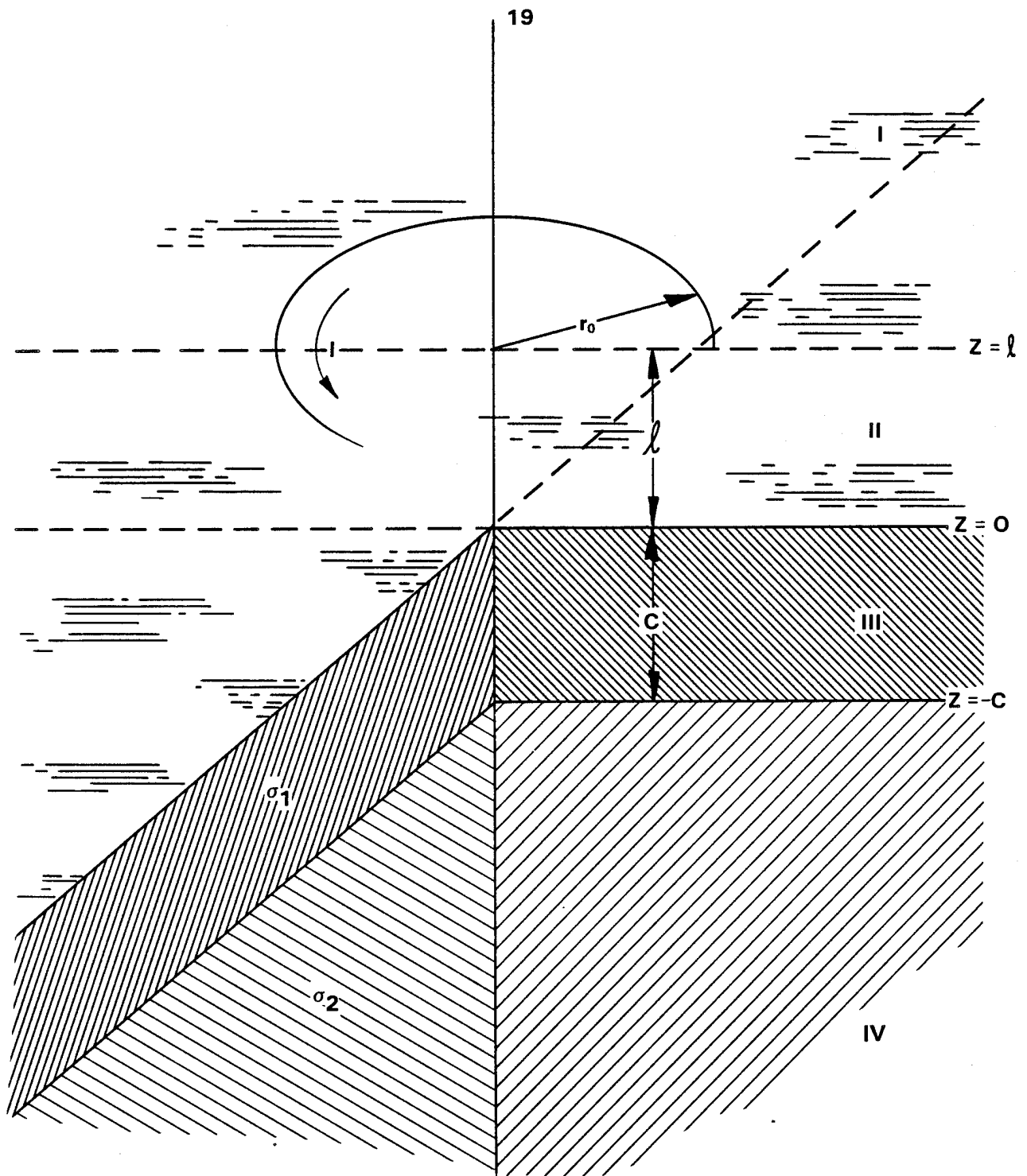

Figure 1. A Delta Function Coil Above a Two-Conductor Plane

$$\left. \frac{\partial A^{(1)}}{\partial z}(r, z) \right]_{z=l} = \left. \frac{\partial A^{(2)}}{\partial z}(r, z) \right]_{z=l} - \mu I \delta(r-r_0) \quad (6)$$

$$A^{(2)}(r, 0) = A^{(3)}(r, 0) \quad (7)$$

$$\left. \frac{\partial A^{(2)}}{\partial z}(r, z) \right]_{z=0} = \left. \frac{\partial A^{(3)}}{\partial z}(r, z) \right]_{z=0} \quad (8)$$

$$A^{(3)}(r-c) = A^{(4)}(r, -c) \quad (9)$$

$$\left. \frac{\partial A^{(3)}}{\partial z}(r, z) \right]_{z=-c} = \left. \frac{\partial A^{(4)}}{\partial z}(r, z) \right]_{z=-c} \quad (10)$$

The following expressions can be obtained for the vector potential in each region:

$$\begin{aligned} \text{Region I } A^{(1)}(r, z) &= \frac{\mu I r_0}{2} \int_0^\infty J_1(\alpha r_0) J_1(\alpha r) e^{-\alpha l - \alpha z} \\ &\quad \left\{ X e^{2\alpha l} + \left[\frac{(\alpha + \alpha_1)(\alpha_1 - \alpha_2) + (\alpha - \alpha_1)(\alpha_2 + \alpha_1) e^{2\alpha_1 c}}{(\alpha - \alpha_1)(\alpha_1 - \alpha_2) + (\alpha + \alpha_1)(\alpha_2 + \alpha_1) e^{\alpha_1 c}} \right] \right\} d\alpha \end{aligned} \quad (11)$$

$$\begin{aligned} \text{Region II } A^{(2)}(r, z) &= \frac{\mu I r_0}{2} \int_0^\infty J_1(\alpha r) e^{-\alpha l} \\ &\quad \left\{ X e^{\alpha z} + \frac{(\alpha + \alpha_1)(\alpha_1 - \alpha_2) + (\alpha - \alpha_1)(\alpha_2 + \alpha_1) e^{2\alpha_1 c}}{(\alpha - \alpha_1)(\alpha_1 - \alpha_2) + (\alpha + \alpha_1)(\alpha_2 + \alpha_1) e^{\alpha_1 c}} e^{-\alpha z} \right\} d\alpha \end{aligned} \quad (12)$$

$$\begin{aligned} \text{Region III } A^{(3)}(r, z) &= \mu I r_0 \int_0^\infty J_1(\alpha r_0) J_1(\alpha r) e^{-\alpha l} \\ &\quad \left\{ \frac{(\alpha + \alpha_1) e^{2\alpha_1 c} e^{\alpha_1 z} + (\alpha_1 - \alpha_2) e^{-\alpha_1 z}}{(\alpha - \alpha_1)(\alpha_1 - \alpha_2) + (\alpha + \alpha_1)(\alpha_2 + \alpha_1) e^{2\alpha_1 c}} \right\} d\alpha \end{aligned} \quad (13)$$

$$\text{Region IV } A^{(4)}(r, z) = \mu I r_0 \int_0^\infty J_1(\alpha r_0) J_1(\alpha r) e^{-\alpha z} \alpha \left\{ \frac{2\alpha_1 e^{(\alpha_2 + \alpha_1)c} e^{\alpha_2 z}}{(\alpha - \alpha_1)(\alpha_1 - \alpha_2) + (\alpha + \alpha_1)(\alpha_2 + \alpha_1) e^{2\alpha_1 c}} \right\} d\alpha \quad (14)$$

where:

$$\alpha_i \equiv \alpha^2 + j\omega\mu\sigma_i$$

and J_1 are Bessel Functions of the First Order

The value of the derivation of the vector potential for a delta coil is that if one assumes that the phase and amplitude of each loop is identical and that the coil has a rectangular crosssection as shown in Figure 2 then the vector potential for a rectangular coil can be written as:

$$A(r, z) \text{ (total)} = \sum_{i=1}^n A_i(r, z) = \sum_{i=1}^n A(r, z, \ell_i, r_i)$$

or

$$A(r, z) \text{ (total)} \int_{r_i}^r \int_{\ell_1}^{\ell_2} A(r, z, r_0, \ell) dr d\ell \quad (15)$$

where

$A(r, z, r_0, \ell)$ is the vector potential produced by a current density $I(\ell_1, r_0)$.

To evaluate the above integral equation for each of the four regions it can be shown that:

$$A^{(i)}(r, z) \equiv F_i(r, r_2, z, \ell_2, M_1, M_2) - F_i(r, r_2, z, \ell_1, M_1, M_2) - F_i(r, r_1, z, \ell_2, M_1, M_2) + F_i(r, r_1, z, \ell_1, M_1, M_2) \quad (16)$$

where:

$$F_1(r, r_m, z, \ell_n, M_1, M_2) = \mu I \bar{r}^2 \sum_{k=0}^{\infty} \frac{2(k+1)}{(2k+1)(2k+3)} \int_0^\infty J_{2k+2}(\alpha r_m) J_1(\alpha r)$$

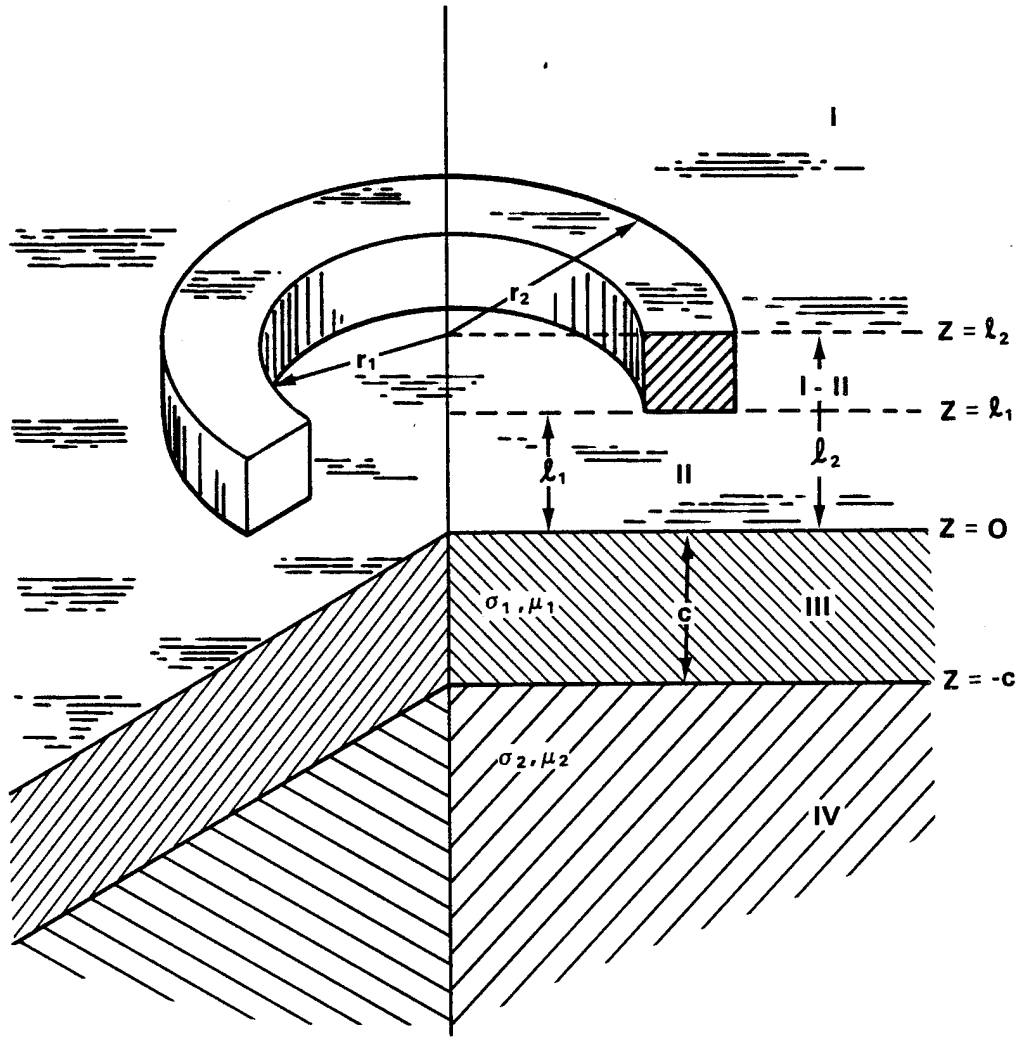

Figure 2. A Coil of Rectangular Cross Section Above a Two-Conductor Plane

$$X \frac{r_m^{-\alpha z}}{\alpha^2 e} \left\{ e^{\alpha \ell} n_{-e}^{-\alpha \ell} n \left[\frac{(\alpha + \alpha_1)(\alpha_1 - \alpha_2) + (\alpha - \alpha_1)(\alpha_2 + \alpha_1) e^{2\alpha_1 c}}{(\alpha - \alpha_1)(\alpha_1 - \alpha_2) + (\alpha + \alpha_1)(\alpha_2 + \alpha_1) e^{2\alpha_1 c}} \right] \right\} d\alpha$$

$$\bar{r} = \frac{r_1 + r_2}{2} \quad (17)$$

$$\bar{r}^2 \omega \mu \sigma_i \equiv M_i$$

In the above, all dimensions are normalized in terms of \bar{r} , defined above, (except \bar{r}).

In region I-II, the region between the top and bottom of the coil, we have to break the problem into two parts, one for the vector potential for the part of the coil below the point of interest, and the other for the part of the coil above the point. The total vector potential is the sum of the two.

$$\frac{z}{r} \equiv z$$

$$\bar{r} \alpha \equiv \alpha$$

$$A^{(12)}(r, z) = F_1(r, r_2, z, \ell_2 = z, M_2) - F_1(r, r_1, z, \ell_2 = z, M_1, M_2) \\ - F_1(r, r_2, z, \ell_1, M_1, M_2) + F_1(r, r_1, z, \ell_1, M_1, M_2) \\ + F_2(r, r_2, z, \ell_2, M_1, M_2) - F_2(r, r_1, z, \ell_2, M_1, M_2) \\ - F_2(r, r_2, z, \ell_2 = z, M_1, M_2) + F_2(r, r_1, z, \ell_1 = z, M_1, M_2) \quad (18)$$

This problem has been solved for the general case of n-layers of conductors using a matrix notation. The magnitude of the vector potential can be expressed as:

$$A(r, z) = \iint G(r, z; r', z') J(r', z') dr' dz' \quad (19)$$

where $G(r, z; r', z')$ is a Green's Function for a δ -Function Current at (r', z') , and $J(r', z')$ is a Bessel function of the first order at (r', z') .

$$\left[\frac{\partial^2}{\partial r^2} + \frac{1}{r} \frac{\partial}{\partial r} - \frac{1}{r^2} + \frac{\partial^2}{\partial z^2} - j\omega\mu\sigma + \omega^2\mu\varepsilon \right] G(r, z; r', z')$$

$$= -\mu\delta(r-r')\delta(z-z') \quad (20)$$

where μ , ε , and σ are the permeability, permittivity, and conductivity, of the medium respectively.

Green's function for a coil located in an n-layered medium with a unit current δ -function coil located below $k^1 - 1$ and $k - 1$ conductors, is:

$$G^{(n)}(r, z; r', z') = \int_0^\infty [\beta_n(\alpha) e^{-\alpha n z} + C_n(\alpha) e^{\alpha n z}] J_1(\alpha r) d\alpha \quad (21)$$

for $n=1, 2, \dots, k-1, k, 1', 2', \dots, k'-1, k'$ where $J_1(x)$ is a Bessel

function of the first kind and the first order and we have defined

$$\alpha_n^2 = \alpha^2 + j\omega\mu_n\sigma_n - \omega^2\mu_n\varepsilon_n.$$

$$\left[G^{(n)}(r, z; r', z') \right]_{z=z_n} = \left[G^{(n+1)}(r, z; r', z') \right]_{z=z_n} \quad (22)$$

and

$$\left[\frac{1}{\mu_n} \frac{\partial G^{(n)}(r, z; r', z')}{\partial z} \right]_{z=z_n} = \left[\frac{1}{\mu_{n+1}} \frac{\partial G^{(n+1)}(r, z; r', z')}{\partial z} \right]_{z=z_n}$$

$$+ \delta_{n,k} \delta(r-r') \quad (23)$$

To apply these equations is extremely tedious involving $2(k + k' - 1)$ linear equations in $2(k + k' - 1)$ unknowns. The problem can be simplified from a notational standpoint by using a matrix formulation. If we define the following matrices, the column matrix,

$$\bar{a}_n = \begin{bmatrix} B_n \\ C_n \end{bmatrix} \quad (24)$$

and the 2 by 2 transformation matrix, $T_{n+1, n}$, whose elements are:

$$(T_{n+1, n})_{11} = \frac{1}{2} (1 + \beta_{n+1, n}) e^{(\alpha_{n+1} - \alpha_n) z_n} \quad (25)$$

$$(T_{n+1, n})_{12} = \frac{1}{2} (1 - \beta_{n+1, n}) e^{(\alpha_{n+1} + \alpha_n) z_n} \quad (26)$$

$$(T_{n+1, n})_{21} = \frac{1}{2} (1 - \beta_{n+1, n}) e^{-(\alpha_{n+1} + \alpha_n) z_n} \quad (27)$$

and

$$(T_{n+1, n})_{22} = \frac{1}{2} (1 + \beta_{n+1, n}) e^{-(\alpha_{n+1} - \alpha_n) z_n} \quad (28)$$

Then the boundary condition equations can be written

$$\bar{a}_{n+1} = \bar{T}_{n+1, n} \bar{a}_n \quad (29)$$

for $n=1, 2, \dots, k-1, 1', 2' \dots k'-1$

Both B_k and C_k can be related to the lowest region C_1 using successive transformations:

$$\bar{a}_k = \begin{bmatrix} B_k \\ C_k \end{bmatrix} = \bar{T}_{k, k-1} \bar{T}_{k-1, k-2} \dots \bar{T}_{3, 2} \bar{T}_{2, 1} \bar{a}_1 \quad (30)$$

where

$$a_1 = \begin{bmatrix} O \\ C_1 \end{bmatrix} \quad (31)$$

$$\text{and } \bar{a}_{k'} = \bar{T}_{k', k'-1} \bar{T}_{k'-1, k'-2} \dots \bar{T}_{3', 2'} \bar{T}_{2', 1'} \bar{a}_{1'} \quad (32)$$

$$a_{1'} = \begin{bmatrix} B_{1'} \\ O_{1'} \end{bmatrix} \quad (33)$$

If a 2 by 2 matrix is further defined for the upper region as:

$$\bar{U}(n', 1') = \bar{T}_{n', n'-1} \bar{T}_{n'-1, n'-2} \dots \bar{T}_{2', 1'} \quad (34)$$

$$\bar{V}(n,1) = \bar{T}_{n,n-1} \bar{R}_{n-1,n-2} \cdots \bar{T}_{3,2} \bar{T}_{2,1} \quad (35)$$

Then a_k and a_k can be written as

$$\bar{a}_k = V(k,1) \bar{a}_1 \quad (36)$$

$$\bar{a}_{k'} = V(k',1') a_{1'} \quad (37)$$

Green's functions for regions below the coil then become:

$$G^{(n)}(r,z;r',z') = \int_0^\infty \frac{U_{11}(k',1') e^{-\alpha_0 z'} + U_{21}(k',1') e^{\alpha_0 z'}}{V_{22}(k,1) V_{11}(k',1') - V_{12}(k,1) U_{21}(k',1')} \frac{\alpha r' J_1(\alpha r')}{2\beta_0} \\ \cdot \left\{ V_{12}(n,1) e^{-\alpha n z} + V_{22}(n,1) e^{\alpha n z} \right\} J_1(\alpha r) d\alpha \quad (38)$$

For the region above the coil Green's Function is written as:

$$G^{(n')}(r,z;r',z') = \int_0^\infty \frac{V_{12}(k,1) e^{-\alpha_0 z} + V_{22}(k,1) e^{\alpha_0 z}}{V_{22}(k,1) V_{11}(k',1') - V_{12}(k,1) U_{11}(k',1')} \frac{\alpha r' J(\alpha r')}{2\beta_0} \\ \cdot \left\{ U_{11}(n',1') e^{-\alpha n' z} + U_{21}(n',1') e^{\alpha n' z} \right\} J_1(\alpha r) d\alpha. \quad (39)$$

The matrix elements of $\bar{U}(n',1')$ can be expressed explicitly for $3' \leq n' \leq k'$

$$U_{\ell 1}(n',1') = \frac{1}{2^{n'-1}} \exp \left[(-1)^1 \alpha_1 z_1 - (-1)^\ell \alpha_n z_{n'-1} \right] \sum_{i_1}^{1,2} \sum_{i_2}^{1,2} \sum_{i_3}^{1,2} \cdots \\ \sum_{i_{n'-3}}^{1,2} \sum_{i_{n'-2}}^{1,2} \left[1 + (-1)^{i_1 + \ell} \beta_{n',n'-1} \quad 1 + (-1)^{i_{n'-2} + 1} \beta_{2',1'} \right] \quad (40)$$

$$\prod_{s=1}^{n'-3} \left[1 + (-1)^{i_s + i_{s+1}} \beta_{n'-s,n'-s-1} \right] \cdot \exp \left[\sum_{s=1}^{n'-2} (-1)^{i_s} \alpha_{n'-s} (z_{n'-s} - z_{n'-s-1}) \right]$$

$$V_{\ell 2}(n,1) = \frac{1}{2^{n-1}} \exp \left[(-1)^2 \alpha_1 z_1 - (-1)^\ell \alpha_n z_{n-1} \right] \sum_{i_1}^{1,2} \sum_{i_2}^{1,2} \sum_{i_3}^{1,2} \cdots \sum_{i_{n-3}}^{1,2} \sum_{i_{n-2}}^{1,2}$$

$$\begin{aligned}
& \cdot \left[1 + (-1)^{i_1 + \ell} \beta_{n, n-1} \quad 1 + (-1)^{i_{n-1} + 2} \beta_{2, 1} \right] \\
& \cdot \prod_{s=1}^{n-3} \left[1 + (-1)^{i_s + i_{s+1}} \beta_{n-s, n-s-1} \right] \\
& \cdot \exp \left[\sum (-1)^{i_s} \alpha_{n-s} (z_{n-s} - z_{n-s-1}) \right]
\end{aligned} \tag{41}$$

From these matrix elements all electromagnetic quantities can be calculated. The vector potential becomes:

$$\begin{aligned}
A^{(n')} (r, z) &= n_c I \int_{\ell_1}^{\ell_2} \int_{r_1}^{r_2} G^{(n')} (r, z; r' z') dr' dz' \\
&= \frac{1}{2} n_c I \int_0^{\infty} \frac{1}{\beta_o \alpha_o \alpha (V_{22} U_{11} - V_{12} U_{21})} \cdot \left[V_{12} e^{e \alpha_o \ell_1} + V_{22} e^{\alpha_o \ell_2} \right] \\
& \cdot \left[1 - e^{-\alpha_o (\ell_2 - \ell_1)} \right] J(r_2, r_1) \\
& \cdot \left[U_{11}(n', 1') e^{-\alpha_{n'} z} + U_{21}(n', 1') e^{\alpha_{n'} z} \right] J_1(\alpha r) d\alpha
\end{aligned} \tag{42}$$

$$\text{where } J(r_2, r_1) = \int_{\alpha r}^{\alpha r_2} x J_1(x) dx \tag{43}$$

$$\begin{aligned}
A^{(n)} (r, z) &= \frac{1}{2} n_c I \int_0^{\infty} \frac{1}{\beta_o \alpha_o \alpha (V_{22} U_{11} - V_{12} U_{21})} \left[U_{11} e^{-\alpha_o \ell} + U_{21} e^{\alpha_o \ell_2} \right] \\
& \cdot \left[1 - e^{-\alpha_o (\ell_2 - \ell_1)} \right] J_1(r_2, r_1) \left[V_{12}(n, 1) e^{-\alpha_n z} + V_{12}(n, 1) e^{\alpha_n z} \right] \\
& \cdot J_1(\alpha r) d\alpha
\end{aligned} \tag{44}$$

$$\begin{aligned}
A^{(c)}(r, z) &= n_c I \left\{ \int_{r_1}^z \int_{r_1}^{r_2} G^{(k')} (r, z; r' z') dr' dz' + \int_z^{\ell_2} \int_{r_1}^{r_2} G^{(k)} (r, z; r' z') dr' dz' \right\} \\
&= \frac{1}{2} n_c I \int_0^\infty \frac{J(r_2, r_1) J_1(\alpha r)}{\beta_o \alpha_o \alpha (V_{22} U_{11} - V_{12} U_{21})} \left\{ (U_{11} e^{-\alpha_o z} + U_{21} e^{\alpha_o z}) \right. \\
&\quad \cdot (V_{12} e^{-\alpha_o \ell_1} + V_{22} e^{\alpha_o z}) \left[1 - e^{-\alpha_o (z - \ell_1)} \right] + (V_{12} e^{-\alpha_o z} + V_{22} e^{\alpha_o z}) \\
&\quad \left. \cdot (U_{11} e^{-\alpha_o z} + U_{21} e^{\alpha_o \ell_2}) \left[1 - e^{-\alpha_o (\ell_2 - z)} \right] \right\} d\alpha \quad (45)
\end{aligned}$$

This formulation is particularly useful since it lends itself to computer solution. If a calculated value of the property is all that is required rather than an analytical expression then $U(n^1, 1^1)$ and $V(n, 1)$ matrices can be calculated directly by a simple iterative process on a computer. One can define two primed matrices as:

$$V_{\ell, 2}(n, 1) = \frac{1}{2^{n-1}} e^{-(-1)^\ell \alpha_n z_{n-1} + (-1)^2 \alpha_1 z_1} V_{\ell, 2}(n) \quad (46)$$

and

$$U_{\ell, 1}(n', 1') = \frac{1}{2^{n'-1}} e^{-(-1)^\ell \alpha_n z_{n'-1} + (-1)^\ell \alpha_1 z_1} U_{\ell, 1}(n') \quad (47)$$

then the numerical value of two elements of a modified transformation matrix,

$$t_{i, 2} \equiv \left[1 + (-1)^{i+2} \beta_1 / \beta_2 \right] = V_{i, 2}(2, 1) \quad i=1, 2 \quad (48)$$

then the numerical value for the four elements of the transformation to the next layer area given by:

$$t_{ij}(n, n-1) \left[= 1 + (-1)^{i+j} \beta_{n-1} / \beta_n \right] \exp \left[(-1)^j \alpha_{n-1} (z_{n-1} - z_{n-2}) \right] \quad (49)$$

from this we calculate:

$$V'_{12}(n,1) = t_{11}(n,n-1)V'_1(n-1,1) + t_{12}(n,n-1)V'_{22}(n-1,1) \quad (50)$$

$$V'_{22}(n,1) = t_{21}(n,n-1)V'_{12}(n-1,1) + t_{22}(n,n-1)V'_{22}(n-1,1) \quad (51)$$

Successive transformation matrices for the lower regions can be obtained by repeating this procedure for the remaining regions.

The preceding calculations are complex and cumbersome; however, with the aid of computer techniques to evaluate the integrals, they provide a means for generating theoretical electromagnetic properties for any multilayered problem. This proceeding development follows the approach used by Dodds, Deeds, and Cheng and is in fact a compilation of calculations taken from several of their reports.¹⁴ For a complete treatment of these problems the above references should be consulted.

Experimental Measurements

Using an RF vector voltmeter three hand wound pancake coils were evaluated at LLL. Maxfield wound the coils and assisted in making the measurements. Measurements were made to determine the sensitivity of the probes at various frequencies to both conductor and non-conductor thickness (lift-off). The physical and electrical properties of the three probes are listed in Table 1. Three different sets of samples were evaluated. The first set consisted of three pieces of physically deposited aluminum having thicknesses of 3.86, 5.05, and 6.45 μm . The second set was made of six samples consisting of the following thicknesses of PVD aluminum.

51.82, 51.31, 48.77, 48.77, 46.74, and 46.74 μm .

The third set was PVD copper with the following thicknesses, 25.4, 50.8, and 127.0 μm . All of these samples were deposited on 101.6 μm of kapton. The lift-off determinations were made by placing successive thicknesses of 25.4 μm kapton on these samples. The thickness variation data is given in tabular form in Tables 2, 3, 4, and 5. For the 3.86 to 6.45 μm samples the best thickness sensitivity was achieved with the 5.3 μH impedance probe at a frequency of 1.5 MHz, while the best thickness sensitivity for the thicker aluminum (46.74 to 51.82 μm) was shown for frequencies less than 1.0 MHz with a 0.25 μH impedance probe. The best thickness sensitivity for copper was achieved at 0.5 MHz with the 5.3 μH probe.

The lift-off data is given in graphical form in Figures 3 through 6. Lift-off measurements were made at two frequencies, 3.2, and 32 MHz. These two frequencies were chosen as a result of

Table 1. Physical and Electrical Properties of the Pancake Coils (Planar Coils)

Coil Designation	Number of Turns	Outside Diameter (cm)	Resistance (Ω)	Inductance L_c (μ H)
A	78	0.90	5.66	38.2
B	52	0.90	2.50	17.0
C	26	0.45	55.00	5.3

theoretical calculations of variation in coil impedance with conductor substrate thickness for various lift-off values. These calculations indicate that 3 MHz might be adequate but that a frequency of 30 MHz would be less sensitive to conductor substrate variations. These calculations are shown in graphical form in Figures 7 and 8. As seen in Figure 3, at 3.2 MHz with a 6.45 μ m substrate, lift-off is a function of both phase and amplitude. At 32 MHz for lift-off measurements in excess of 50.8 μ m, lift-off is essentially a function of the amplitude only.

Similarly, for the 50.8 μ m aluminum substrate at 3.2 MHz lift-off is a function of both phase and amplitude while at 32 MHz above 25.0 μ m lift-off, lift-off is purely a function of amplitude.

As result of these measurements, the following conclusions were made.

- In designing a dual frequency system to measure conductor and nonconductor thickness for the 6.45 μ m substrate, the lower frequency component should be in the area of 1.5 MHz and the high frequency component around 30 MHz.
- For the 50.8 μ m substrate, the low frequency component, a frequency of 0.5 MHz should be used while 30 MHz appears best for the high frequency component.

Since 30 MHz may be difficult to achieve, a 3.0-MHz coil might be adequate; however, the separation would not be as good, and the influence of substrate thickness variation would be considerably greater than with a 30-MHz probe.

Table 2. Sensitivity of Phase and Amplitude for Aluminum in the 3.76 to 6.45 μm Range at Various Frequencies Using Probe C

Thickness (μm)	Frequency (MHz)							
	0.5		1.05		1.5		5.0	
	A*	B*	A	B	A	B	A	B
3.76	7.00	69	13.8	74	18.0	70	41	62
4.05	7.15	68	13.5	71	17.0	66	36	63
6.45	7.20	67	13.0	68	16.3	62	36	68

A* is Amplitude (mV).

B* is Phase (degrees).

System Construction

The multi-frequency system is being constructed. The design of an NDT microprocessor module has been built and the analog digital interface is now being designed. The initial system will be a dual frequency unit. The schematic is Figure 9.

The control and data reduction operations are performed by the microprocessor unit. A functional schematic of this system is Figure 10.

An analog-to-digital converter with 12-bit resolution will be used (Figure 10).

For display purposes two LED displays will be used. These are integral display units having the drivers built into the display module.

The modeling of the problem is performed on a mainframe computer and the calibration coefficients obtained from this analysis are then programmed. This work will be performed in the next phase of development.

ACCOMPLISHMENTS

A thorough study of the theoretical aspects of eddy current measurements was made. The exact solution for the two-layered

Table 3. Sensitivity of Phase and Amplitude for Aluminum in the 46.74 to 51.82 μm Range for Various Frequencies Using Probe C

Thickness (μm)	Frequency (MHz)					
	1.0		1.59		3.2	
	A*	B*	A	B	A	B
51.82	7.0	64	10.3	71	17.5	79
51.31	7.0	64	10.0	71	17.5	79
48.77	7.0	64	9.8	71	17.5	79
48.77	7.0	64	9.9	71	17.5	79
46.74	7.0	63	9.9	71	17.5	78
46.74	7.0	63	9.8	71	17.5	78

A* is Amplitude (mV)

B* is Phase (degrees).

and n-layered composite structure was derived following the approach used by Dodd, and others.¹⁵ From this treatment it can be shown that simultaneous measurements of multi-layered composites is feasible. Experimental measurements made using a vector voltmeter show that a frequency of 1.5 MHz offered the best sensitivity for aluminum conductors in the 6.4 μm range, while the high frequency component should be at least 30 MHz. For the 50.8 μm material, the low frequency component should be in the area of 0.5 MHz while the high frequency should be approximately 30 MHz.

Using the Dodd designs, a two-frequency eddy current system has been built. The data reduction and control of this system is handled by a microprocessor module. In order to implement this equipment the calibration coefficients for the materials in question must be obtained.

FUTURE WORK

The next phase of this project will involve development of software. Since Bendix does not have a compatible computer

Table 4. Sensitivity of Phase and Amplitude for Aluminum in the 46.74 to 51.82 μm Range for Various Frequencies Using Probe B

Thickness (μm)	Frequency (MHz)							
	1		6		10		30	
	A*	B*	A	B	A	B	A	B
51.82	16.6	63.0	78	82	134.0	84	127.0	69
51.31	16.0	62.5	78	82	133.0	84	127.0	69
48.77	16.2	61.5	78	82	132.0	84	127.0	69
48.77	16.3	61.0	78	82	131.0	84	127.0	69
46.74	16.5	60.0	77	82	131.0	84	126.0	70
46.74	16.5	60.0	77	82	131.0	84	126.0	70

A* is Amplitude (mV).

B* is Phase (degrees).

system, this work will have to be accomplished at LLL or ORNL. A mathematical model of the laminate and its parameters must be developed. Probe coil parameters must be optimized, and the actual experimentally measured values must be compared with the theoretical model so that the calibration coefficients can be determined.

Table 5. Sensitivity of Phase and Amplitude for Aluminum in the 24.4 to 127.0 μm Range at Various Frequencies Using Probe C

Thickness μm	Frequency (MHz)							
	0.5		1.0		2.0		4.0	
	A	B*	A	B	A	B	A	B
24.4	4.9	40	6.9	56	11.5	70	21	78
50.8	4.2	47	6.4	64	11.5	74	21	81
127.0	3.9	56	6.7	69	12.2	76	22	81

A* is Amplitude (mV).

B* is Phase (degrees).

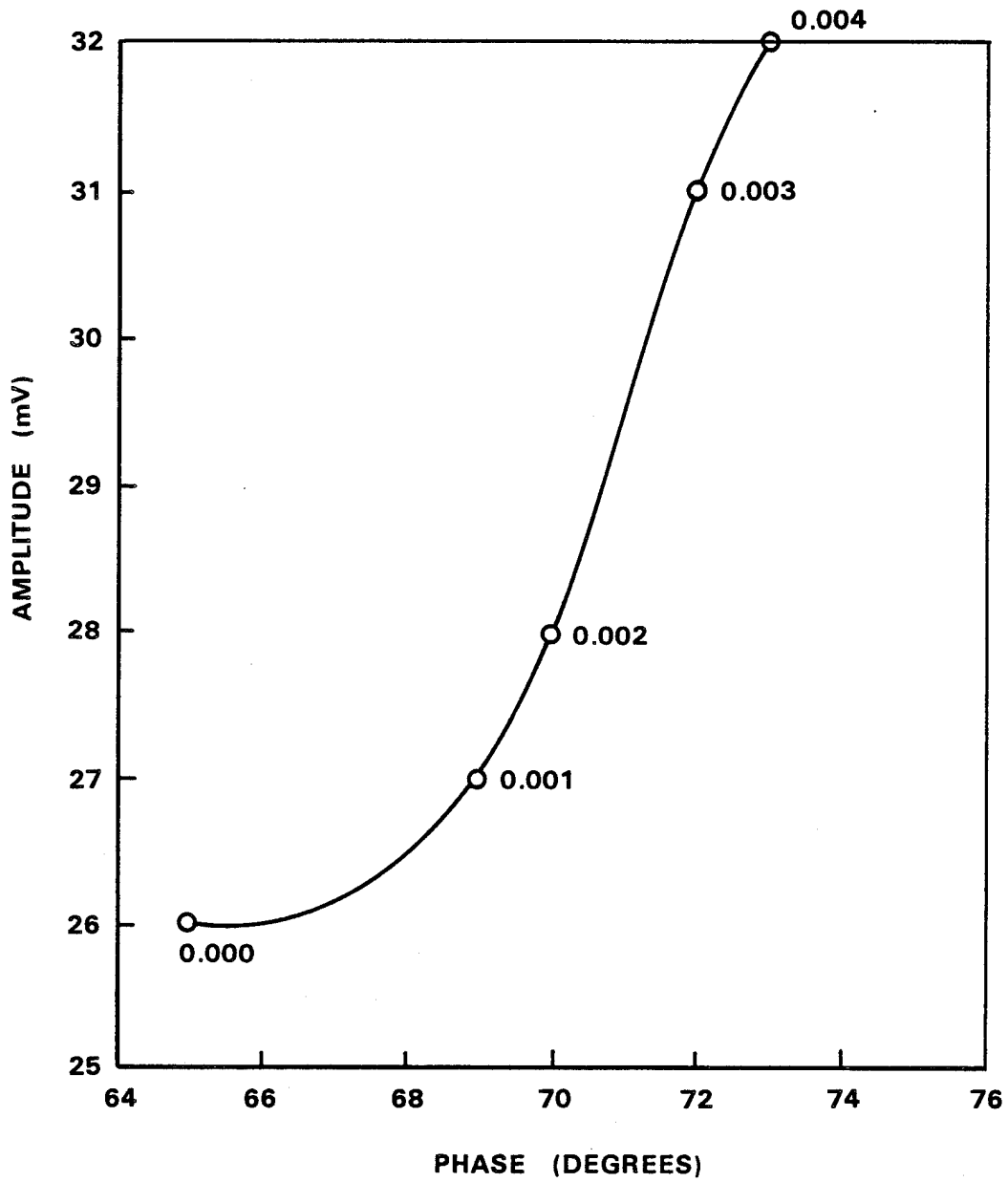

Figure 3. Lift-Off Determination at 3.2 MHz, Kapton on 0.25 Mil Aluminum

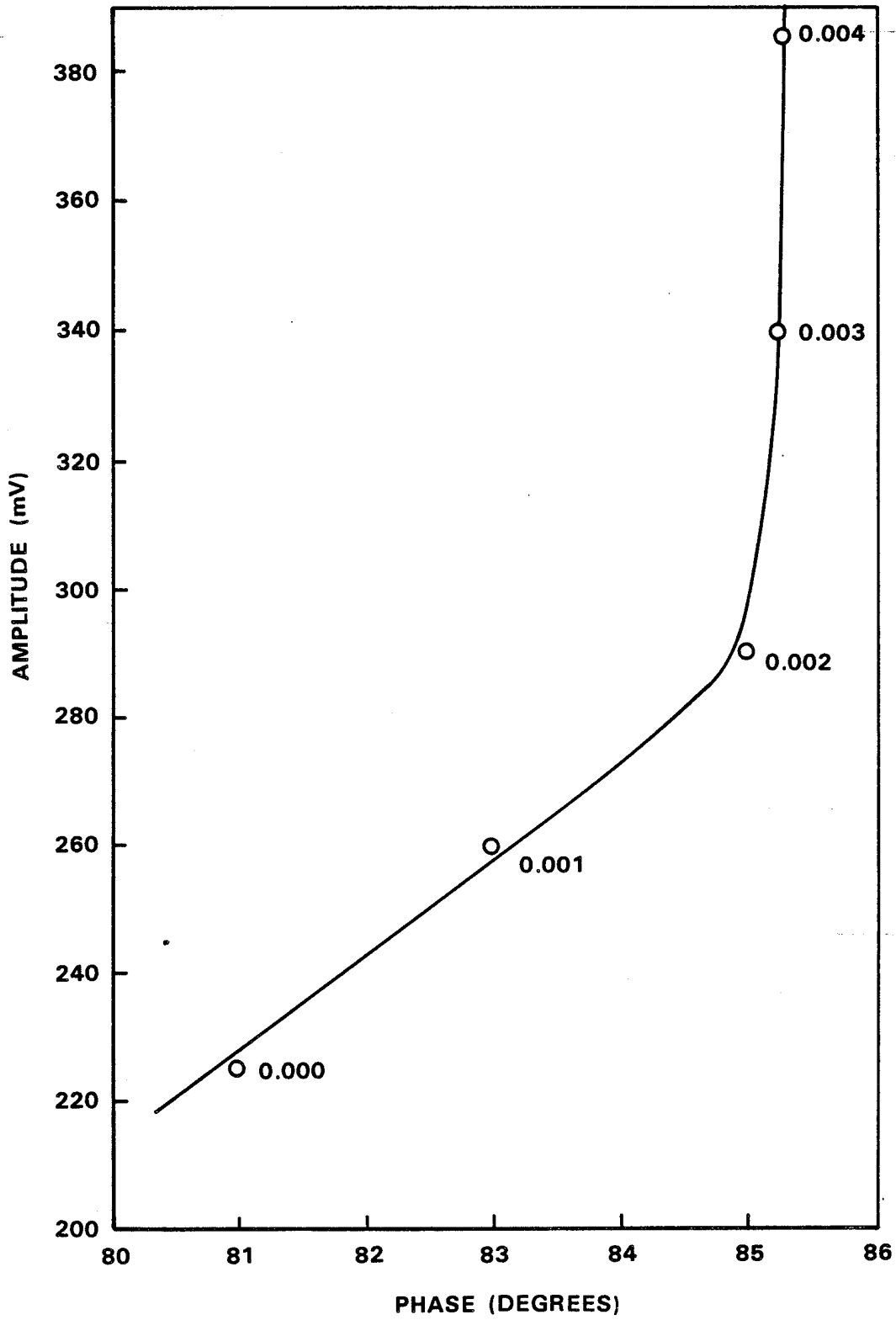

Figure 4. Lift-Off Determination at 32 MHz, Kapton on 0.25 Mil Aluminum

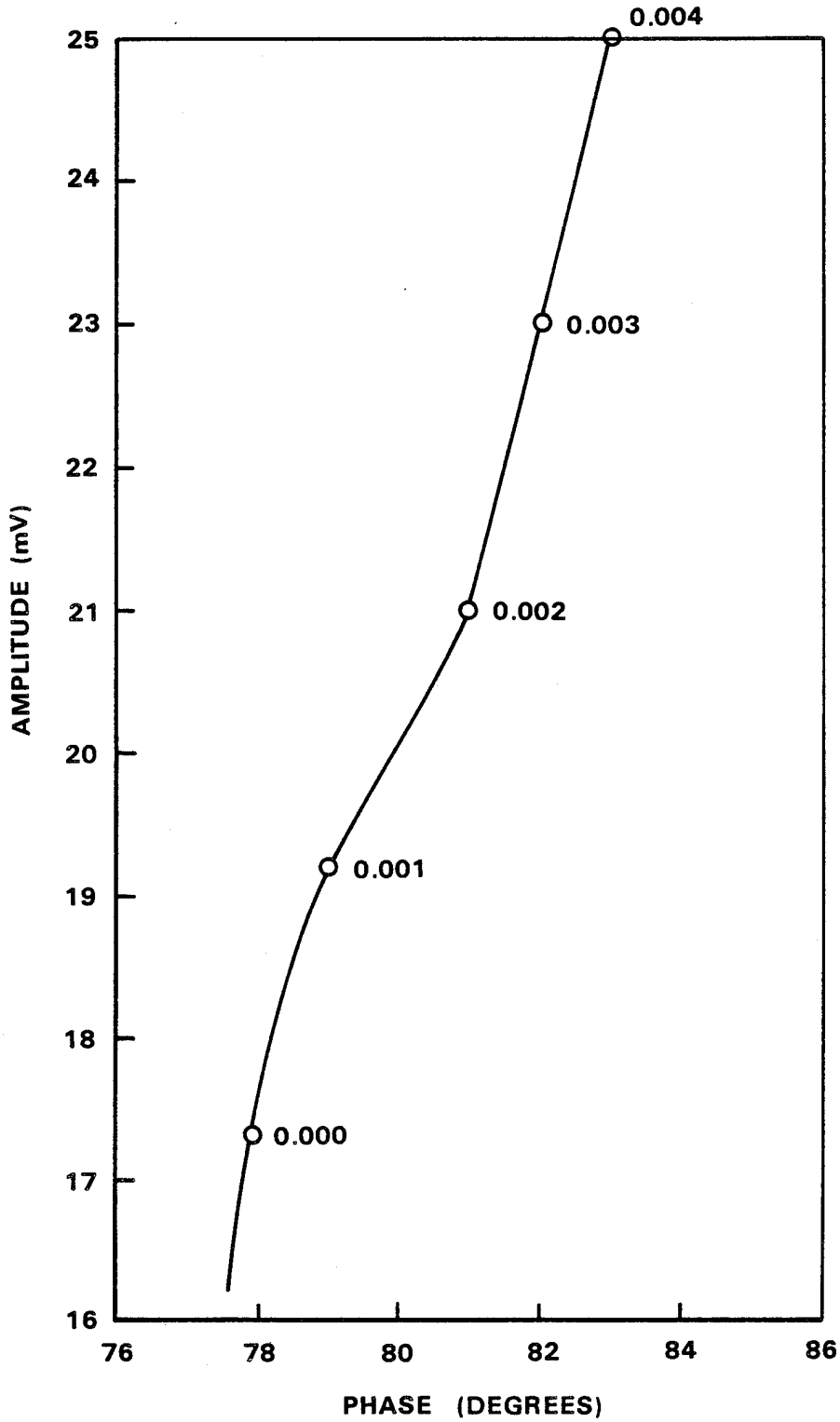

Figure 5. Lift-Off Determination at 3.2 MHz, Kapton on 2 Mil Aluminum

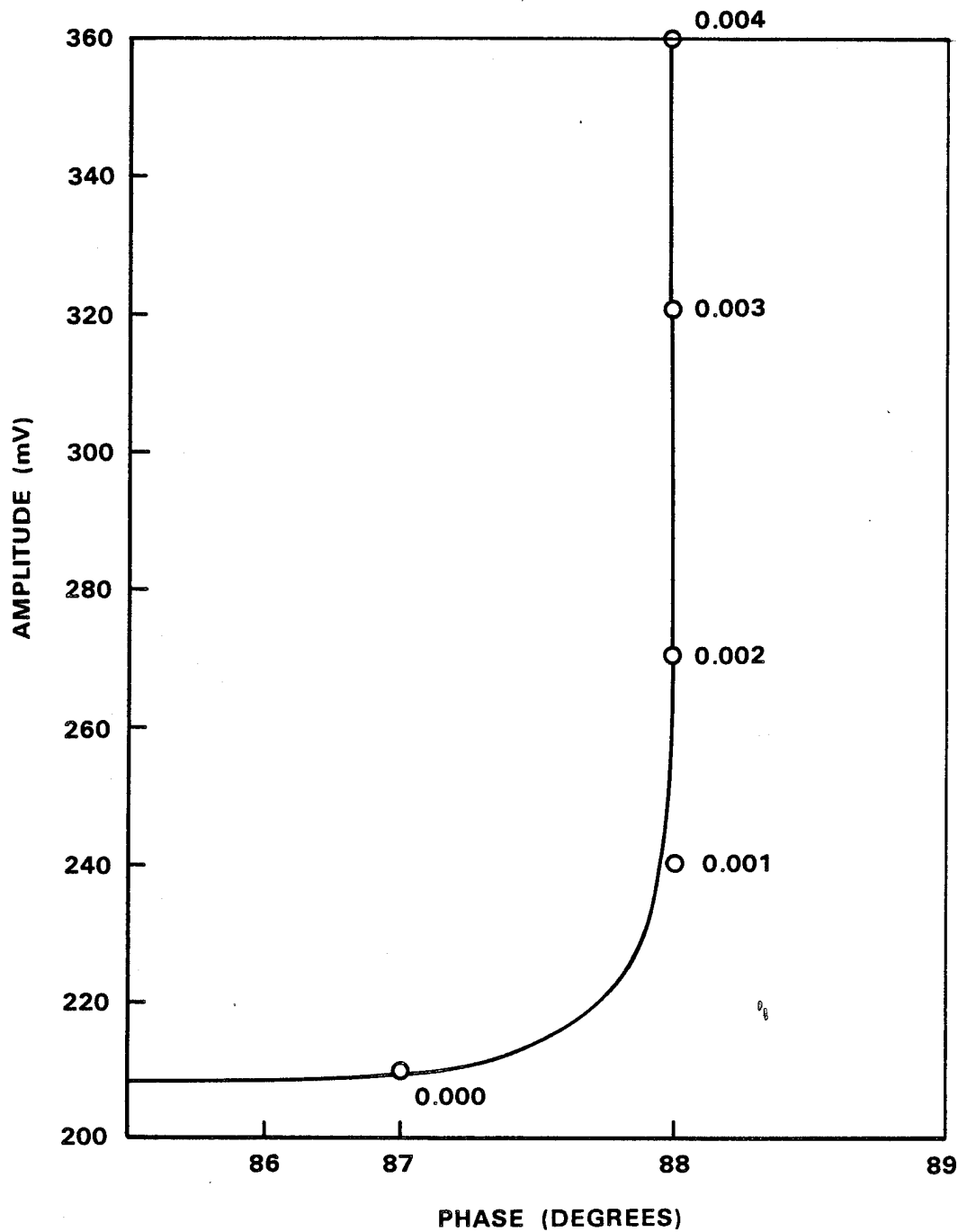

Figure 6. Lift-Off Determination at 32 MHz, Kapton on 2 Mil Aluminum

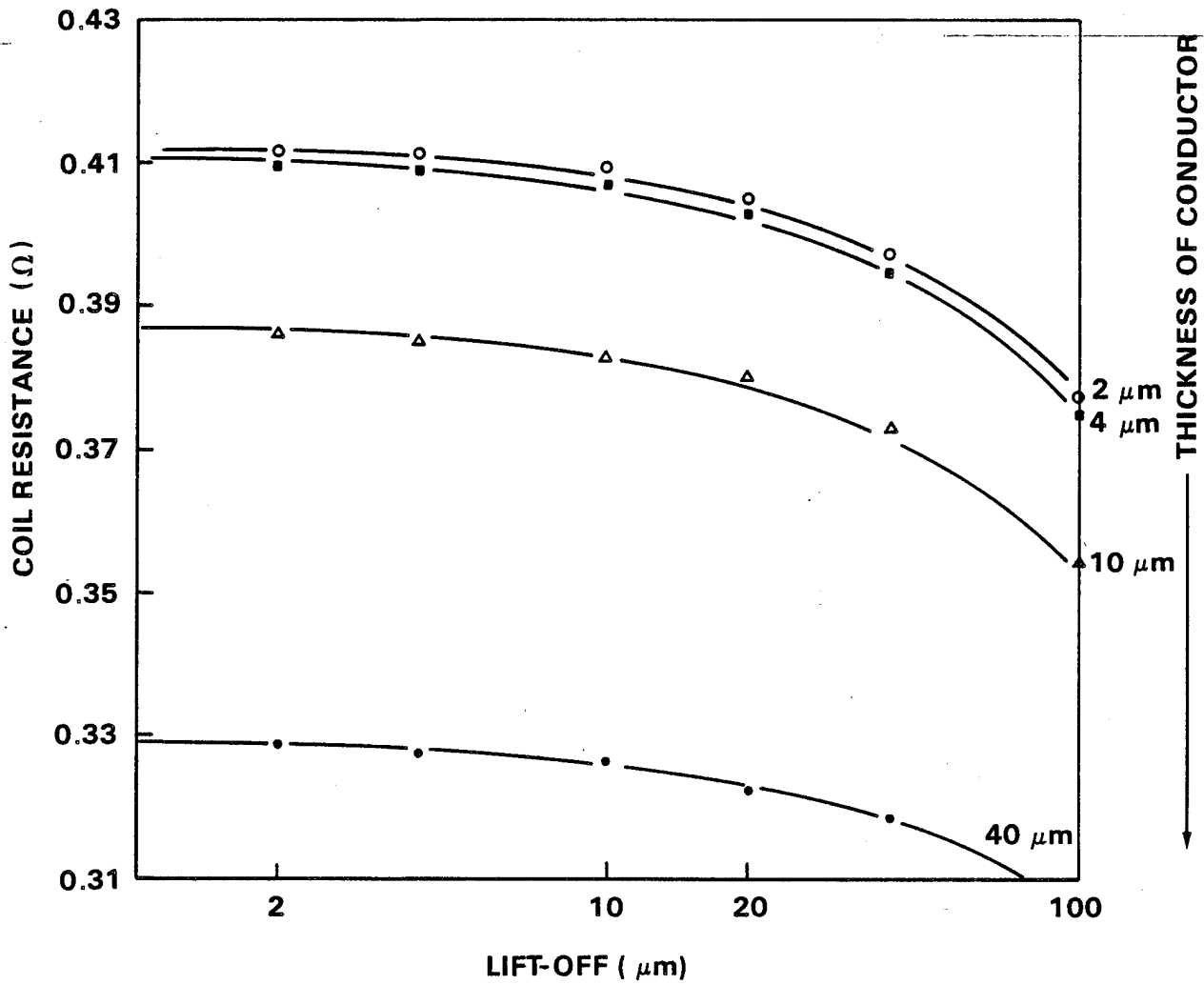

Figure 7. Variation of Coil Resistance With Lift-Off at 3 MHz (Calculated Russian Expression)

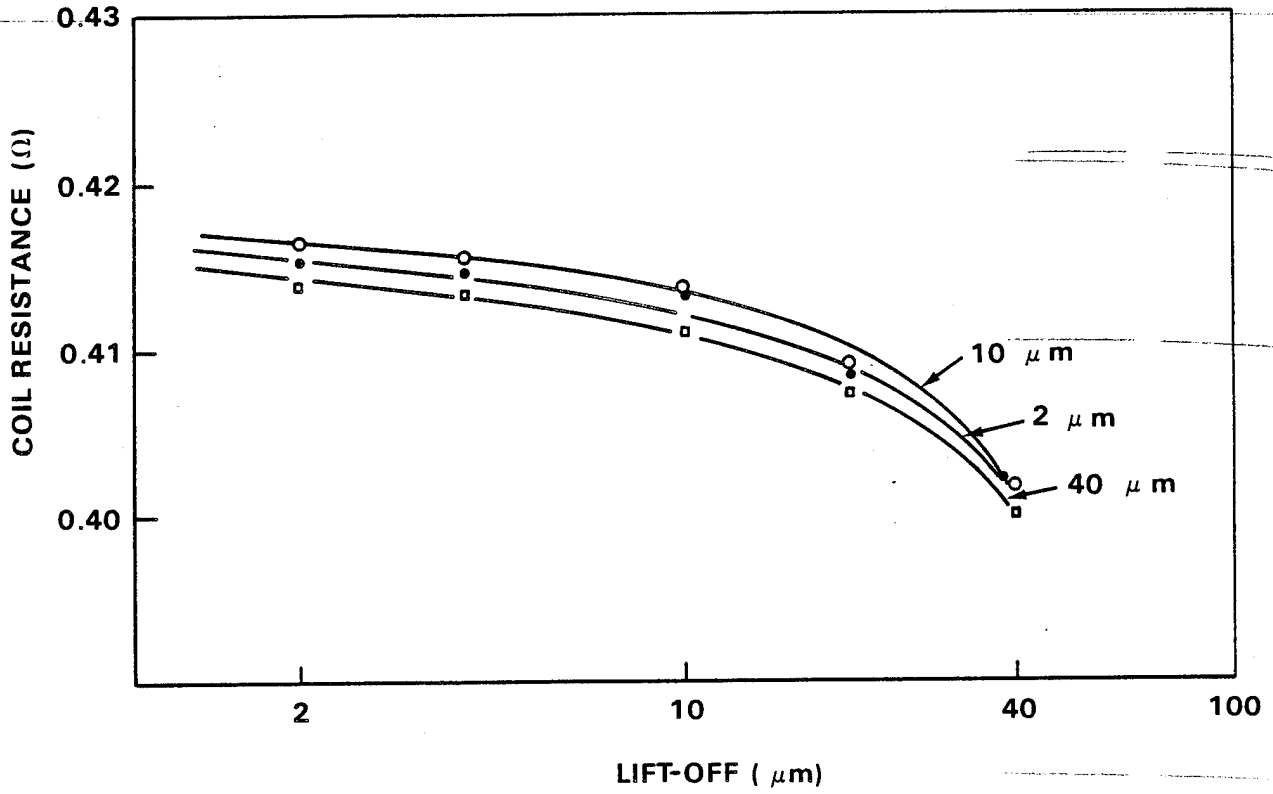

Figure 8. Variation of Coil Resistance With Lift-Off at 30 MHz (Calculated Russian Expression)

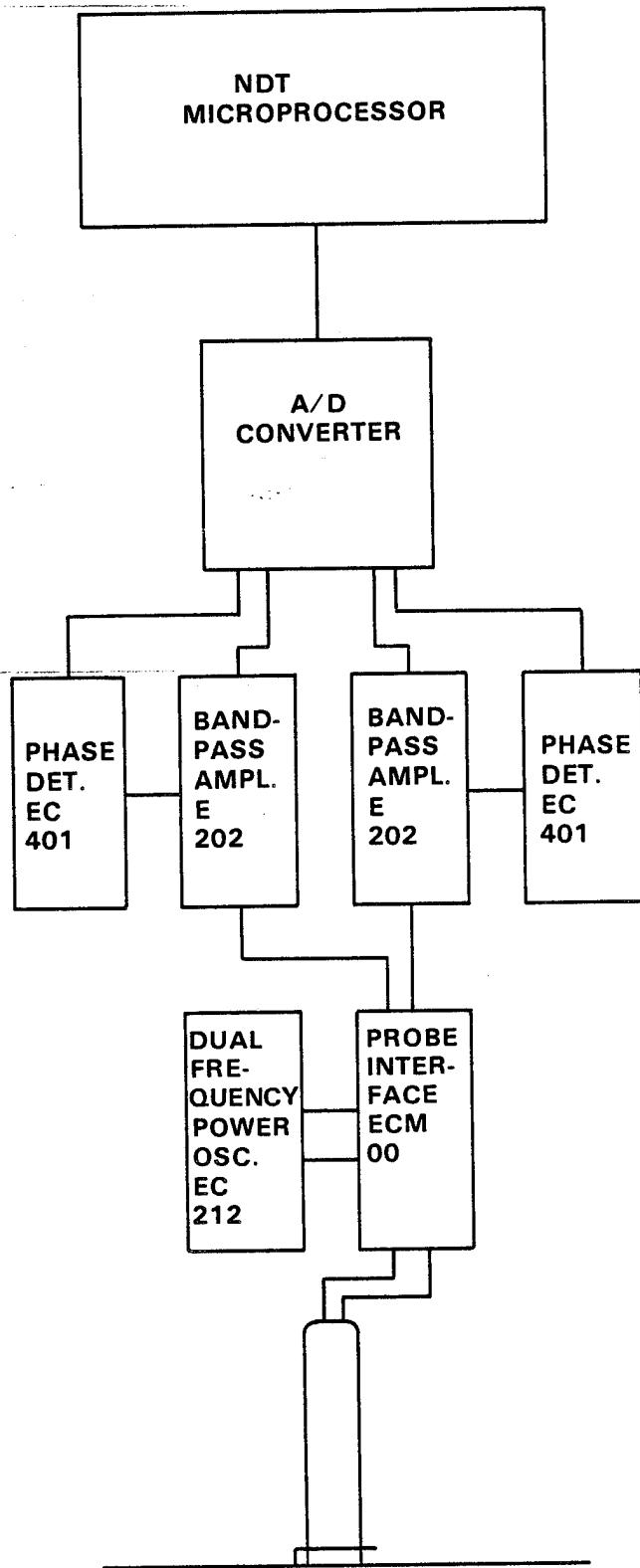

Figure 9. Schematic of a Two-Frequency Eddy Current System

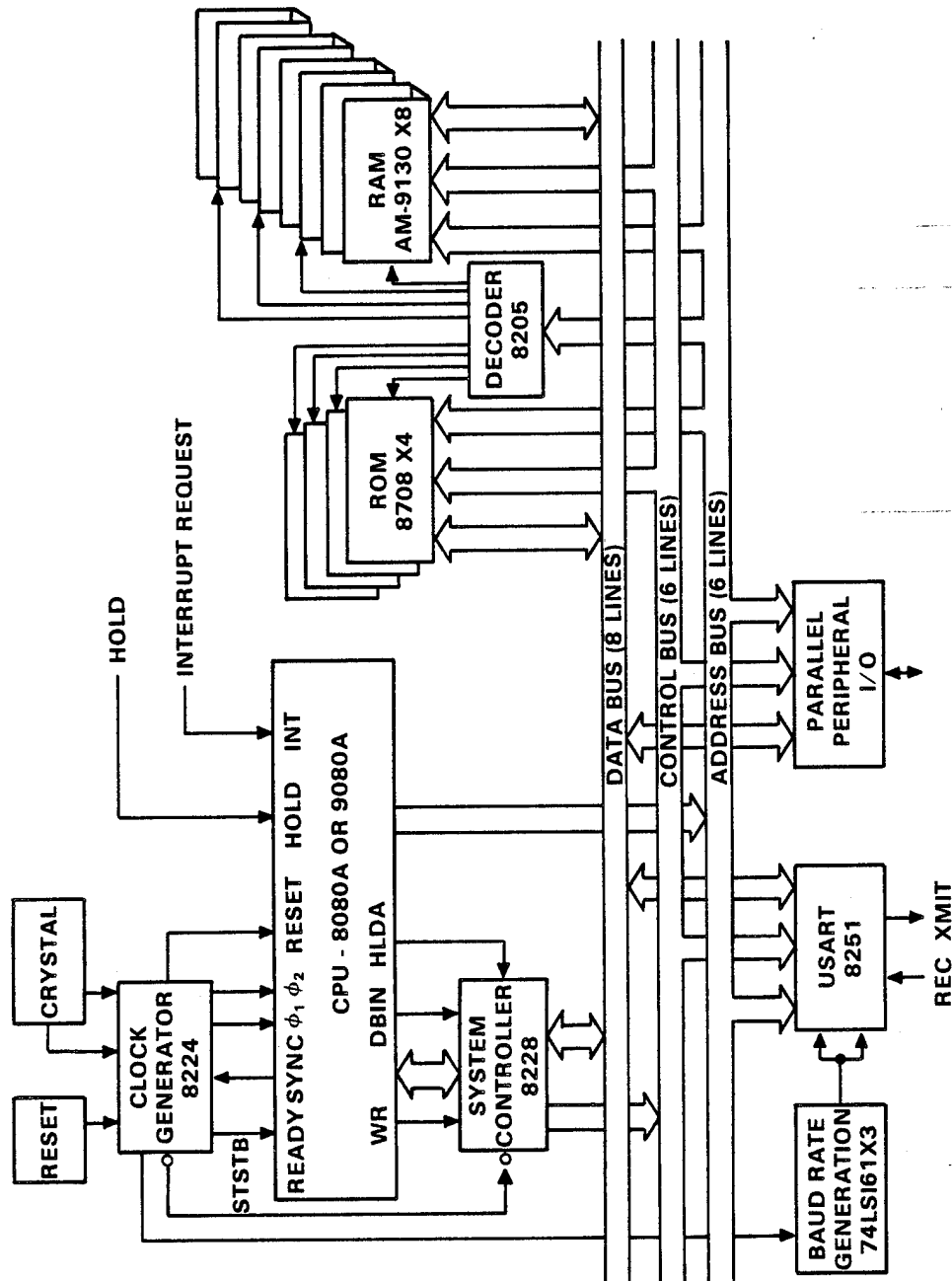

Figure 10. Block Diagram of the NDT Microcomputer
Designed by ORNL

SYMBOL TABLE

A_1 vector potential

α separation constant, unless otherwise defined

$$\alpha_i \equiv \alpha^2 - \bar{r}^2 \omega^2 \mu_i \epsilon_i + j \bar{r}^2 \omega \mu_i \sigma_i$$

$$\alpha_0 \equiv \alpha^2 - \bar{r}^2 \omega^2 \mu_0 \epsilon_0$$

β separation constant, unless otherwise defined

$$\beta_i \equiv \frac{\mu_0}{\mu} \alpha^2 - \bar{r}^2 \omega^2 \mu_i \epsilon_i + j \bar{r}^2 \omega \mu_i \sigma_i$$

$$\beta_0 \equiv \alpha^2 - \bar{r}^2 \omega^2 \mu_0 \epsilon_0$$

δ the classical delta function

e is the exponential function

E is the electrical potential

ϵ is permittivity; ϵ_0 is the permittivity of free space

G is Green's function

I is current, unless otherwise defined

j is $\sqrt{-1}$, unless otherwise defined

J is current density, unless otherwise defined

L is inductance

ℓ_0 is distance of delta coil above surface

ℓ_i is the coil vertical dimension

M is the mutual inductance

M_i is the mutual inductance of coils = $\bar{r}^2 \omega \mu \sigma_0$.

N is the number of turns per unit cross-sectional area

n is the number of turns

v is the radial dimension of cylindrical coordinates

r_0 is the nominal dimension of the delta coil

r_i is the radial dimensions of coils

\bar{r} is the average coil radius = $\frac{r_1+r_2}{2}$

σ is the conductivity of a conductor,

σ_i is the conductivity of individual conductor layers transformational

T is a transformation matrix

U_{ij} is a transformational matrix

μ permeability of conductor, μ_0 permeability of free space

μ_i permeability of a conductor layer.

V is the voltage

V_{ij} is a transformational matrix

ω is the angular frequency

Z is the complex impedance

z is the vertical dimension in cylindrical coordinates.

REFERENCES

- ¹Abel, W. B., Beta-Backscatter Measurements of Aluminum Coatings on Mylar Substrates (Topical Report). Bendix Kansas City: BDX-613-1028, Rev., September 13, 1974 (Available from NTIS).
- ²Hughes, D. E., Phil. Mag. 8 (5), 50 (1879)
- ³Forster, Friedrich, Z. Metallk 43, 163-171 (1952)
- ⁴Forster, Friedrich, and Kurt Stambke, Z. Metallk 45 (4), 166-179 (1954).
- ⁵Forster, Friedrich, Z. Metallk 45 (4), 197-199 (1954)
- ⁶Hochschild, R., "Electromagnetic Methods of Testing Metals," Progress in Nondestructive Testing, Vol. 1 (McMillan Company, New York, 1959).
- ⁷Vein, P. R., J. Electron, Control 13, 471-494 (1962)
- ⁸Cheng, Davis H.S., "The Reflected Impedance of a Circular Coil in Proximity of a Semi-Infinite Medium" Phd. Dissertation, University of Missouri, 1964.
- ⁹Burrows, Michael Leonard, A Theory of Eddy Current Flow Detection, University Microfilms, Inc., Ann Arbor, Michigan, 1969.
- ¹⁰Dodd, C. V.; Deeds, W. E., "Eddy Current Impedance Calculated by a Relaxation Method," pp. 300-314 in Proceedings of the Symposium on Physics and Nondestructive Testing, Southwest Research Institute, San Antonio, Texas, 1963.
- ¹¹Sobolev, V. S.; Shkarlet, H. V., Contact and Transmission Transducers for Inspection by the Eddy Current Method; translated by Perry Vodit Translation Service, Ithaca, New York (1967).
- ¹²Dodd, C. V.; Deeds, W. E.; Luquire, J. W.; and Spoeri, W. G., Some Eddy-Current Problems and Their Integral Solutions ORNL-4384, April, 1969.
- ¹³Dodd, C. V., "Solution to Electromagnetic Induction Problems, Ph.d. Dissertation, University of Tenn., ORNL-TM1842, (1967).
- ¹⁴Dodd, C. V.; Cheng, C. C.; Deeds, W. E.; "General Analysis of Probe Coils Near Stratified Conductors." International Journal of Nondestructive Testing, Vol. 3, pp. 109-130 (1971).

¹⁵Dodd, C. V.; Cheng, C. C.; Simpson, W. A.; Deeds, D. A.; Smith, J. H.; The Analysis of Reflection Type Coils for Eddy Current Testing, ORNL-TM-4107 (1973).

BDX-613-2407

SIMULTANEOUS MEASUREMENT OF MULTILAYERED COMPOSITES, R. V. Heckman, Milestone, June 1980.

A theoretical treatment of the eddy current problem involving a two-layered conductor laminate is presented for a rectangular cross section coil, with experimental eddy current measurements indicating that a frequency of 1.5 MHz should be used to measure a 6.45 μm aluminum conductor, a 0.5 MHz frequency should be used to measure a 50.8 μm aluminum conductor, and a frequency of 30 MHz should

SPECIAL PROJECTS: Nondestructive Measurement
SIMULTANEOUS MEASUREMENT OF MULTILAYERED COMPOSITES, R. V. Heckman, Milestone, BDX-613-2407, June 1980.

A theoretical treatment of the eddy current problem involving a two-layered conductor laminate is presented for a rectangular cross section coil, with experimental eddy current measurements indicating that a frequency of 1.5 MHz should be used to measure a 6.45 μm aluminum conductor, a 0.5 MHz frequency should be used to measure a 50.8 μm aluminum conductor, and a frequency of 30 MHz should

SIMULTANEOUS MEASUREMENT OF MULTILAYERED COMPOSITES, R. V. Heckman, Milestone, BDX-613-2407, June 1980.

A theoretical treatment of the eddy current problem involving a two-layered conductor laminate is presented for a rectangular cross section coil, with experimental eddy current measurements indicating that a frequency of 1.5 MHz should be used to measure a 6.45 μm aluminum conductor, a 0.5 MHz frequency should be used to measure a 50.8 μm aluminum conductor, and a frequency of 30 MHz should

be used to measure lift-off. The schematic and the basic design of a two-frequency microprocessor controlled eddy current system is also presented.

be used to measure lift-off. The schematic and the basic design of a two-frequency microprocessor controlled eddy current system is also presented.

be used to measure lift-off. The schematic and the basic design of a two-frequency microprocessor controlled eddy current system is also presented.