



**US Army Corps
of Engineers**
Construction Engineering
Research Laboratories

USACERL Technical Report 96/34
January 1996

Energy Conservation and Air Toxic Compliance Plan for Department of Defense Industrial Facilities

by
Mike C.J. Lin
Jeri I. Northrup
Martin J. Savoie
Robert Lorand
Walter Smith, Jr.
Sheldon Landsburger

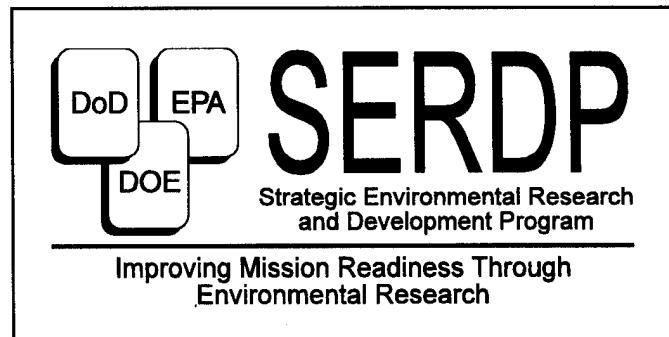

Defense Energy Program Policy Memorandum 91-2, Executive Orders 12759 and 12902, and the Clean Air Act Amendments all impact Department of Defense (DOD) facility operations. Because most of the technologies used by DOD industrial activities are over 40 years old, such energy and environmental directives often exceed facilities' performance capabilities. Cost-effective compliance with these directives requires a thorough evaluation of the activities and their potential for improvements.

This study is part of the Strategic Environmental Research and Development Program, which seeks to develop tools to help DOD industrial operators make informed decisions whether to change/modify processes,

or to adopt new technologies to achieve energy and environmental goals. Initial efforts of this project reviewed DOD industrial operations and developed a Level-I process energy and pollution reduction (PEPR) analysis tool to help installations prepare prioritized implementation plans to meet required energy and environmental goals. A PEPR workshop and an energy/emission review at Pine Bluff Arsenal and a plating process study at Watervliet Arsenal were also conducted. The study concluded that, by aggressively pursuing the PEPR technique, as much as a 70 percent process energy reduction is possible, while collateral economic benefits often surpass the energy savings.

19960311 188

Approved for public release; distribution is unlimited.

DTIC QUALITY INSPECTED 5

The contents of this report are not to be used for advertising, publication, or promotional purposes. Citation of trade names does not constitute an official endorsement or approval of the use of such commercial products. The findings of this report are not to be construed as an official Department of the Army position, unless so designated by other authorized documents.

DESTROY THIS REPORT WHEN IT IS NO LONGER NEEDED

DO NOT RETURN IT TO THE ORIGINATOR

USER EVALUATION OF REPORT

REFERENCE: USACERL Technical Report 96/34, *Energy Conservation and Air Toxic Compliance Plan for Department of Defense Industrial Facilities*

Please take a few minutes to answer the questions below, tear out this sheet, and return it to USACERL. As user of this report, your customer comments will provide USACERL with information essential for improving future reports.

1. Does this report satisfy a need? (Comment on purpose, related project, or other area of interest for which report will be used.)

2. How, specifically, is the report being used? (Information source, design data or procedure, management procedure, source of ideas, etc.)

3. Has the information in this report led to any quantitative savings as far as manhours/contract dollars saved, operating costs avoided, efficiencies achieved, etc.? If so, please elaborate.

4. What is your evaluation of this report in the following areas?

a. Presentation: _____

b. Completeness: _____

c. Easy to Understand: _____

d. Easy to Implement: _____

e. Adequate Reference Material: _____

f. Relates to Area of Interest: _____

g. Did the report meet your expectations? _____

h. Does the report raise unanswered questions? _____

i. General Comments. (Indicate what you think should be changed to make this report and future reports of this type more responsive to your needs, more usable, improve readability, etc.)

5. If you would like to be contacted by the personnel who prepared this report to raise specific questions or discuss the topic, please fill in the following information.

Name: _____

Telephone Number: _____

Organization Address: _____

6. Please mail the completed form to:

Department of the Army
CONSTRUCTION ENGINEERING RESEARCH LABORATORIES
ATTN: CECER-TR-I
P.O. Box 9005
Champaign, IL 61826-9005

REPORT DOCUMENTATION PAGE

Form Approved
OMB No. 0704-0188

Public reporting burden for this collection of information is estimated to average 1 hour per response, including the time for reviewing instructions, searching existing data sources, gathering and maintaining the data needed, and completing and reviewing the collection of information. Send comments regarding this burden estimate or any other aspect of this collection of information, including suggestions for reducing this burden, to Washington Headquarters Services, Directorate for Information Operations and Reports, 1215 Jefferson Davis Highway, Suite 1204, Arlington, VA 22202-4302, and to the Office of Management and Budget, Paperwork Reduction Project (0704-0188), Washington, DC 20503.

1. AGENCY USE ONLY (Leave Blank)		2. REPORT DATE January 1996	3. REPORT TYPE AND DATES COVERED Final
4. TITLE AND SUBTITLE Energy Conservation and Air Toxic Compliance Plan for Department of Defense Industrial Facilities		5. FUNDING NUMBERS FAD 94 080018	
6. AUTHOR(S) Mike C.J. Lin, Jeri I. Northrup, Martin J. Savoie, Robert Lorand, Walter Smith, Jr., and Sheldon Landsburger			
7. PERFORMING ORGANIZATION NAME(S) AND ADDRESS(ES) U.S. Army Construction Engineering Research Laboratories (USACERL) P.O. Box 9005 Champaign, IL 61826-9005		8. PERFORMING ORGANIZATION REPORT NUMBER TR 96/34	
9. SPONSORING / MONITORING AGENCY NAME(S) AND ADDRESS(ES) Executive Director, SERDP Program Office 901 N. Stuart St., Suite 303 Arlington, VA 22203		10. SPONSORING / MONITORING AGENCY REPORT NUMBER	
11. SUPPLEMENTARY NOTES Copies are available from the National Technical Information Service, 5285 Port Royal Road, Springfield, VA 22161.			
12a. DISTRIBUTION / AVAILABILITY STATEMENT Approved for public release; distribution is unlimited.		12b. DISTRIBUTION CODE	
13. ABSTRACT (Maximum 200 words) <p>Defense Energy Program Policy Memorandum 91-2, Executive Orders 12759 and 12902, and the Clean Air Act Amendments all impact Department of Defense (DOD) facility operations. Because most of the technologies used by DOD industrial activities are over 40 years old, such energy and environmental directives often exceed facilities' performance capabilities. Cost-effective compliance with these directives requires a thorough evaluation of the activities and their potential for improvements.</p> <p>This study is part of the Strategic Environmental Research and Development Program, which seeks to develop tools to help DOD industrial operators make informed decisions whether to change/modify processes, or to adopt new technologies to achieve energy and environmental goals. Initial efforts of this project reviewed DOD industrial operations and developed a Level-I process energy and pollution reduction (PEPR) analysis tool to help installations prepare prioritized implementation plans to meet required energy and environmental goals. A PEPR workshop and an energy/emission review at Pine Bluff Arsenal and a plating process study at Watervliet Arsenal were also conducted. The study concluded that, by aggressively pursuing the PEPR technique, as much as a 70 percent process energy reduction is possible, while collateral economic benefits often surpass the energy savings.</p>			
14. SUBJECT TERMS Department of Defense energy conservation environmental compliance		industrial facilities	15. NUMBER OF PAGES 100
			16. PRICE CODE
17. SECURITY CLASSIFICATION OF REPORT Unclassified	18. SECURITY CLASSIFICATION OF THIS PAGE Unclassified	19. SECURITY CLASSIFICATION OF ABSTRACT Unclassified	20. LIMITATION OF ABSTRACT SAR

Foreword

This study was conducted for Office of the Director of Defense Research and Engineering, under the Strategic Environmental Research and Development Program (SERDP), and was funded by Funding Acquisition Document (FAD) No. 94-080018; Work Unit 94-080018, "Energy Conservation and Air Toxic Compliance Plan for DOD Industrial Facilities." The technical monitor was Dr. John Harrison, Executive Director, SERDP.

The work was performed by the Industrial Operations Division (UL-I) of the Utilities and Industrial Operations Laboratory (UL), U.S. Army Construction Engineering Research Laboratories (USACERL). The USACERL principal investigator was Dr. Mike C.J. Lin. Ralph E. Moshage is Acting Chief, CECER-UL-I; John T. Bandy is Operations Chief, CECER-UL; and Gary W. Schanche is Chief, CECER-UL. The USACERL technical editor was William J. Wolfe, Technical Resources.

COL James T. Scott is Commander and Acting Director, and Dr. Michael J. O'Connor is Technical Director of USACERL.

Contents

SF 298	1
Foreword	2
List of Figures and Tables	5
1 Introduction	9
Background	9
Objective	11
Approach	12
Scope	13
Mode of Technology Transfer	13
Metric Conversion Factors	14
2 DOD Industrial Energy Consumption	15
Process Energy Estimation	15
Energy Management Analysis Conducted by IDA	17
3 Army Industrial Facilities Review	19
Site Visit at Holston Army Ammunition Plant	19
Site Visit at Rock Island Arsenal	21
Current Energy Projects at Rock Island Arsenal	24
Site Visit at Aberdeen Proving Ground (APG) and the Army Environmental Center (AEC)	26
4 Review of Emission Inventory and Energy Conservation Programs	28
Naval Air Emission Tracking System (NAETS)	28
Army Air Pollution Emission System (APES)	29
Renewables and Energy Efficiency Planning (REEP)	30
5 Characterization of Heavy Metal Air Toxic Sources	31
6 Watervliet Arsenal Plating Process Study	32
Plating Shops Information	32
Process Flow in Most Shops	33
Plating Data Needs	34
Current Data Collection and Reduction	36
Future Data Collection Needs	36

	Database Development for NAETS Plating Module	36
	Plating Module Emission Factors	37
	Materials Data Base	37
	Reports	37
	NAETS Implementation	38
	Hardware	39
	Methodology of Instruction	39
	Evaluation of NAETS Implementation	39
7	Process Energy and Pollution Reduction Level I Analysis	41
	Energy and Emission Review at Pine Bluff Arsenal	41
	Background	44
	Review Objectives, Goals, and Review Team	47
	Facility Cost Structure Establishing Value	49
	Analyzing the Existing Process and Energy Infrastructure	49
	Creating the New Process	70
	Estimating Dollar Benefits Based on a Level I Analysis	72
	Preliminary Conclusions	73
8	PEPR Analysis Tool Development	75
	Overview/Scope	75
	Basic Structure	76
	Future Use of the Program	80
9	Conclusions and Recommendations	81
	Conclusions	81
	Recommendations	82
	References	83
	Appendix A: Characterization of Potential Metal Air Toxics	84
	Appendix B: Audit Response From Pine Bluff Arsenal	96
	Distribution	

List of Figures and Tables

Figures

1	Development of process energy and pollution reduction (PEPR) analysis tool	12
2	DOD process energy consumption, FY 1991, CONUS	15
3	Typical electroplating flow diagram for work	35
4	Steam one-line areas 1, 2, 3, and 4	45
5	One-line electrical balance, PBA	46
6	Primary how-why diagram for process improvements at Pine Bluff Arsenal	48
7	Line No. 1 dipfill	51
8	Line No. 2 dryfill	52
9	WP fill block process flow diagram	53
10	WP fill how-why diagram; improve process operations	59
11	WP fill how-why diagram; improve environmental performance of the process	60
12	WP fill how-why diagram; improve overall productivity of process	61
13	Improve performance of L8A3 production how-why diagram; improve energy effectiveness	62
14	Improve performance of L8A3 production area how-why diagram; reduce environmental pollutants	63
15	Improve performance of L8A3 production area how-why diagram; improve manufacturing productivity	64

16	Improve performance of site-wide central systems how-why diagram No. 1; central thermal system	65
17	Improve performance of site-wide central systems how-why diagram No. 2; central electrical system	66
18	Improve performance of site-wide central sytems how-why diagram No. 3; central environmental systems	67
19	Steam use for boilers 32, 33, and 34	68
20	Weakness analysis of central utility systems	69
A1	Mass size distribution	92
A2	Elemental size distribution	92

Tables

1	Army Materiel Command base energy consumption, FY93	16
2	Achieving process optimization through process change	42
3	Estimating dollar benefits for P.B.A. based on a level I analysis	43
4	Electrical consumption and cost	43
5	Natural gas consumption and cost	44
6	Improvements to optimize the central steam system and improve the effectiveness of energy utilization at the point-of-use	54
7	Improvements to optimize the central electrical system and improve the effectiveness of energy utilization at the point-of-use	54
8	Improvements to optimize the central industrial waste water treatment system, sanitary waste water treatment, central water treatment, and incineration facilities	55
9	Weakness analysis for white phosphorous production line	55
10	Weakness analysis for red phosphorous l8a3 production line	55

11	Process improvements to reduce emissions and energy consumption at the point-of-use	56
12	Process improvements to reduce emissions and energy consumption at the point-of-use	57
13	Central heating plant boilers for production area	68
14	Potential dollar benefits from process improvements at Pine Bluff Arsenal	72
15	Common process steps that could be included in the process module database	76
16	Necessary data for each process module	77
A1	Typical level of Pb and Cd concentrations in several locations	86
A2	USEPA source categories of hazardous elements	86
A3	Industrial sources of hazardous heavy metals	87
A4	Summary of techniques for analyzing the eleven elements	94

1 Introduction

Background

The Department of Defense (DOD) is the largest user of energy within the Federal Government, responsible for the equivalent of 1.6 percent of national energy use. Total cost of petroleum consumed by the DOD in fiscal year 1991 (FY91) was \$6.4 billion. Approximately 1200 Defense installations contain over 400,000 buildings, which occupy 2.5 billion sq ft.* Energy use for Defense installations costs \$2.9 billion per year—a cost aggravated by the fact that the great majority of DOD industrial activities use technologies over 40 years old. Since the end of the cold war, U.S. Defense requirements have changed significantly. This change represents an opportunity to redirect a tremendous national resource towards the environmental challenges in the 1990s. In this climate, recent directives are beginning to apply stricter energy conservation and environmental requirements of DOD installations.

Defense Energy Program Policy Memorandum (DEPPM) 91-2 and Executive Order 12759 assign energy efficiency goals for Federal facilities for FY2000 as compared to an FY85 base year. Specifically, each DOD component is directed to prescribe policies and establish appropriate measures of energy efficiency under which the aggregate of its industrial energy-consuming facilities will increase energy efficiency by at least 20 percent in FY2000 in comparison to FY85. On 8 March 1994, Vice President Gore announced that President Clinton had signed Executive Order 12902, which calls for an increased energy efficiency in Federal industrial facilities by at least 20 percent by 2005 compared to FY 90 and requires agencies to implement all cost-effective water conservation projects (Section 302(b)). The Executive Order also increases the energy savings requirement for agencies to 30 percent by 2005 compared to FY85 in Btu per gross square foot (Section 301(a)).

Title III of the Clean Air Act Amendments of 1990 directs the U.S. Environmental Protection Agency (USEPA) to establish criteria controlling the emissions of 189 air toxics. The majority of these air toxic emissions come from industrial activities. Regulations governing the control of emissions of these chemicals from industrial

* Metric conversion factors are provided on p 14.

activities are being developed by USEPA beginning in 1992 for 41 source categories, and continuing through 2000 for the remaining 250 source categories.

These new energy and environmental directives in most instances exceed the performance capabilities of DOD's installed industrial technologies. Currently fewer than one third of the Army's industrial facilities are on target to meet the required 1985 energy reduction goals for industrial facilities of 8 percent by 1995. Moreover, the goal has been increased to 20 percent by 2000. This increase will require Army industrial facilities to adopt an even more accelerated energy reduction program. Beginning in 1995, the Clean Air Act Amendments will require DOD industrial facilities to significantly reduce their overall emissions of air toxic chemicals.

Future DOD industrial facilities will employ state-of-the-art production technologies being developed jointly by the Army's ManTech program and DOE's Sandia National Laboratory. However, problems can still be anticipated to occur in DOD industrial base where cost effective compliance with these directives will require a thorough evaluation of current DOD industrial activities and their potential for improvements. To address the energy and environmental concerns, a 5-year proposal was submitted to the Strategic Environmental Research and Development Program (SERDP) for funding.

SERDP was established by Congress in Public Law 101-510 (Title 10, U.S.C. 2901-2904) on 5 November 1990. SERDP is a joint multi-agency effort that supports environmental quality research, development, demonstration, and applications programs. The SERDP Council (the principal policy and program decisionmaking body) has guided the combined efforts of the DOD, Department of Energy (DOE), and the U.S. Environmental Protection Agency (USEPA) to ensure that SERDP is aggressively implemented. SERDP uses six thrust areas to execute the strategy: (1) cleanup, (2) compliance, (3) conservation, (4) pollution prevention, (5) global environmental change, and (6) energy conservation/renewable resources.

This study addresses the compliance and energy conservation thrust areas simultaneously. Compliance includes research and development to support environmental monitoring, waste treatment, end-of-pipe recycling and disposal, marine risk assessment, and environmental management. Compliance also demands an understanding of the fate and transport of defense-related wastes and pollutants, as well as ecological and health impacts of these materials on the environment. The energy conservation/renewable resources thrust area addresses the generation, transmission, use, and conservation of energy.

Major objectives for energy conservation/renewable resources include:

1. By the year 2005, identify methods and systems to reduce facility energy consumption by 20 percent (as compared to that in 1990) in terms of both energy per square foot and "process" energy
2. Reduce carbon dioxide emissions to 1990 levels by the year 2000
3. Reduce all other emissions to comply with regulations
4. Use alternate energy sources.

To reach these objectives, the DOD must formulate and adopt a strategy to meet the DEPPM goals for industrial energy efficiency and Clean Air Act toxic emissions. Developing a process energy and pollution reduction (PEPR) analysis tool is an early step in meeting this goal since such a tool would help DOD industrial operation managers make informed decisions whether to change/modify processes, or adopt new technologies to reduce energy consumption and comply with environmental goals.

Objective

The overall objective of this project was to develop a strategy to help DOD installations meet DEPPM goals for industrial energy efficiency and Clean Air Act air toxic emissions reduction in a cost effective manner. The specific objective of this part of the project was to identify technologies for the existing DOD industrial base that reduce energy consumption and air toxic emissions by improving the performance and operation of industrial processes. This project builds on the following ongoing research programs:

1. Modernization of energy production facilities by the Army, Air Force, and the Electric Power Research Institute (EPRI, Palo Alto, CA)
2. Air pollutant emission source inventory surveys by the Army and Navy
3. Industrial energy auditing surveys being conducted by the Army
4. Air toxic emissions source survey developed by Navy and Air Force for the Navy facilities in San Diego, CA
5. Industrial air toxic emissions research being conducted by the USEPA's Air and Energy Engineering Research Laboratory,

Approach

Several tasks were defined and carried out to help develop a process energy and pollution reduction (PEPR) analysis tool to assist DOD industrial operation managers make informed decisions whether to change/modify processes or to adopt new technologies to achieve energy reduction and environmental compliance goals (Figure 1):

1. Regulatory reviews of Clean Air Act Amendments and Energy Policy Act as well as Executive Orders were performed.
2. A literature search on heavy metal air toxic sources was carried out.
3. Data requirements were determined by conducting a data sources search.
4. Air toxics and other pollutant emission data were found from some U.S. Army Construction Engineering Research Laboratories (USACERL) developed emission inventory programs such as the Air Pollution Emission System (APES) sponsored by Army Environmental Center (AEC) and the Naval Air Emission Tracking System (NAETS) sponsored by Naval Facility Engineering Service Center (NFESC).

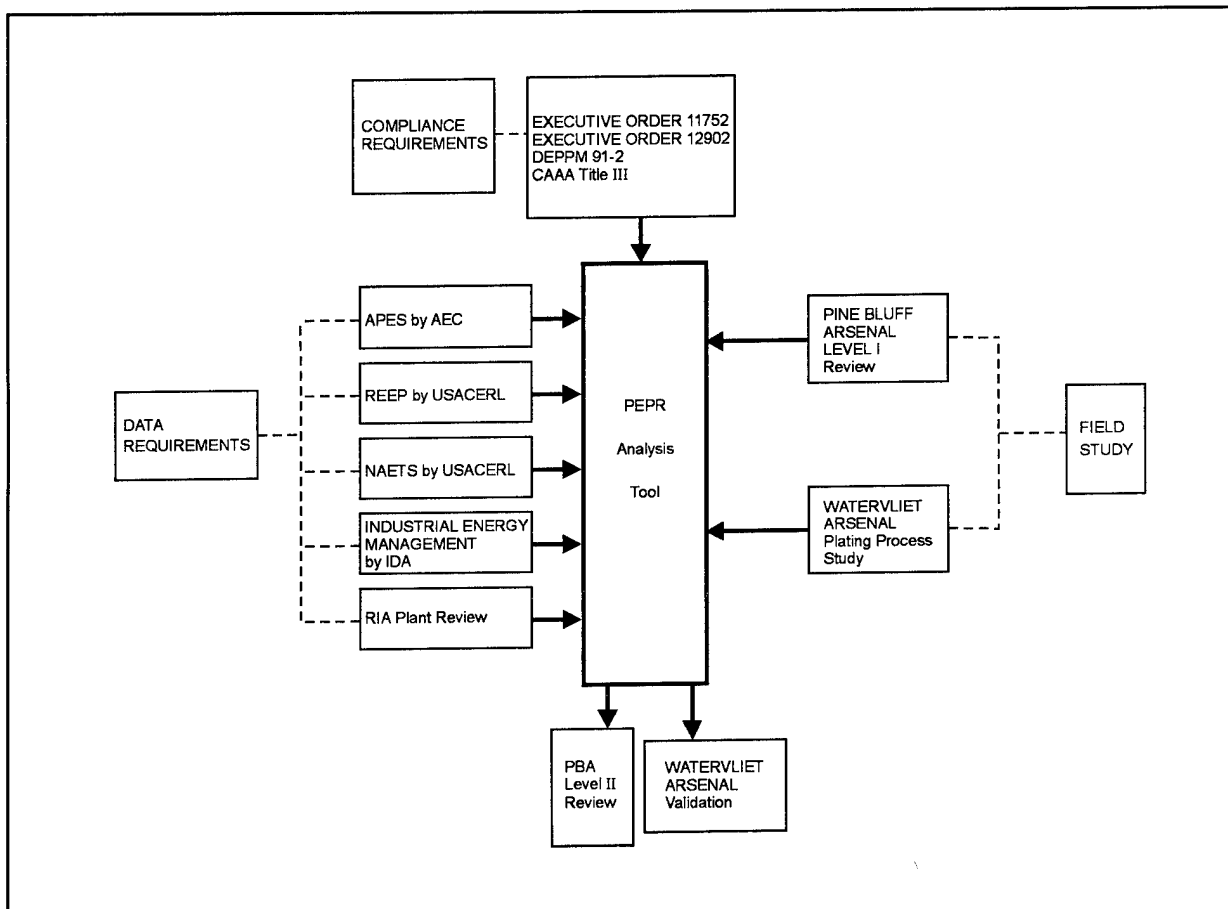

Figure 1. Development of process energy and pollution reduction (PEPR) analysis tool.

5. Overall energy consumption data and conventional energy conservation opportunities were found in the USACERL-developed Renewables and Energy Efficiency Planning (REEP) program. Data inputs from DOD industrial facility inspections and a study by the Institute for Defense Analysis (IDA), Alexandria, VA, on DOD industrial energy management were also taken into consideration.
6. Field studies were conducted at Pine Bluff Arsenal (Level I process review) and Watervliet Arsenal (plating process study).

Milestones for this project were:

- | | | |
|-----------------------------------------------|-----------|-------|
| • Identify significant industrial energy uses | September | 1994 |
| • Identify significant air toxic sources | February | 1995 |
| • Develop level-I PEPR analysis tool | September | 1995. |

Scope

This study is part of the Strategic Environmental Research and Development Program. A software tool will be developed to help DOD industrial operators to achieve the energy and environmental goals. In addition to energy and environmental engineering, group dynamics and human potential research techniques are included in the tool development package. This project attempts to extend the mass and energy flow modeling concepts to industrial activities and their potential air toxic emissions. Initial efforts are focused on developing a level-I PEPR analysis program that will help installations prepare a prioritized implementation plan to meet the required energy reduction and environmental compliance goals. The product developed from this project could be used by all DOD industrial operations. It is also applicable to commercial industries of similar operations.

Mode of Technology Transfer

The information from this study will be used to develop and validate a PEPR analysis program for the energy and emission intensive processes. It is anticipated that the information derived from this study will be disseminated in the Army Research, Development, and Acquisition Bulletin, and that the results of an energy/emission review and of the software tool development be presented at the Industrial Energy Technology Conference.

Metric Conversion Factors

The following metric conversion factors are provided for the standard units of measure used throughout this report:

$$1 \text{ in.} = 25.4 \text{ mm}$$

$$1 \text{ ft} = 0.305 \text{ m}$$

$$1 \text{ lb} = 0.453 \text{ kg}$$

$$1 \text{ psi} = 6.89 \text{ kPa}$$

$$1 \text{ ton} = 0.907 \text{ metric ton}$$

$$^{\circ}\text{F} = (^{\circ}\text{C} \times 1.8) + 32$$

2 DOD Industrial Energy Consumption

To solve the energy and emission-related problems for DOD industrial facilities, it is necessary to find out first which installations are the major process energy consumers and pollutant emitters. Identifying the major processes in these energy and emission intensive installations is required to develop cost-effective solutions. A review of past work on process energy estimation and process energy reduction studies is presented below.

Process Energy Estimation

Estimating DOD process energy consumption is not an easy task. A recent USACERL-developed DOD utility energy database showed that, in FY91, the CONUS process energy consumptions for Army, Navy, Air Force and DLA/DC are approximately 8.5, 15.5, 12.5 and 0.2 trillion Btu respectively. About 14 percent of the total DOD CONUS energy is used in various processes. Note that an installation's identification of energy "process energy" is voluntary. The reported values may be lower than metered values. Figure 2 shows the reported process energy consumptions for each of the four services,

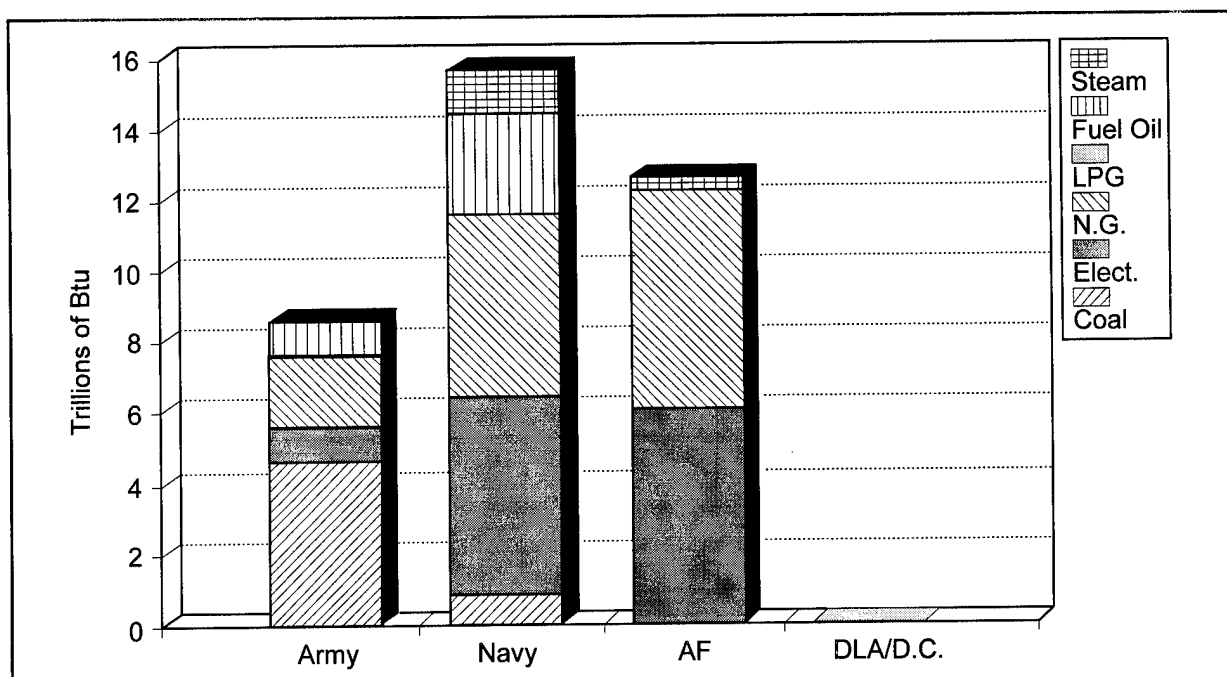

Figure 2. DOD process energy consumption, FY 1991, CONUS.

and the amount of each source of energy (fuel oil, LPG, natural gas, coal, electricity, or steam) used by each service.

A previous USACERL study (Sliwinski 1983) estimated process energy consumptions by linear regression assuming that energy usage is a function of both weather-related and production-related variables. Table 1 lists the percentages of the total energy consumed as process energy for Army industrial facilities and the total energy consumption in 1992 for the Army Materiel Command (AMC) installations. On average, about 46 percent of the total energy was consumed as process energy. In 1992, AMC used about 11.8 trillion Btu in processes. At this rate of consumption, a 20 percent savings in process energy would amount to 2.4 trillion Btu, or at \$5/MBtu, approximately \$12 million. USACERL's DOD utility energy database shows that the Army used one quarter of the DOD process energy. This implies that a 20 percent reduction in process energy could save the DOD about \$50 million a year.

Table 1. Army Materiel Command base energy consumption, FY93.

AMC Rank	Installation Name	Total MBTU/yr	Energy Mbtu/hr	Operator G or C	Process %Pro. Eng	Energy MBtu/Hr
1	Aberdeen Proving Ground	2404995	275	G	41	113
2	Redstone Arsenal	1614038	184	G	50	92
3	Holston Army Ammo Plant	1366074	156	C	70	109
4	Rock Island Arsenal	1262472	144	G	39	56
5	Radford Army Ammo Plant	1191737	136	C	68	93
6	Picatinny Arsenal	1053072	120	G	27	32
7	Fort Monmouth	984888	112	G	23	26
8	Lake City Army Ammo Plant	899831	103	C	16	16
9	Red River Army Amm0 Depot	846610	97	G	71	69
10	Pine Bluff Arsenal	728624	83	G	75	62
11	Stratford Army Engine Plant	690761	79	C	—	—
12	Detroit Arsenal	681964	78	G	59	46
13	Tobyhanna Army Depot	675671	77	G	—	—
14	Anniston Army Depot	666293	76	G	60	46
15	Lone Star Army Ammo Plant	659007	75	C	36	27
16	White Sands Missile Range	637172	73	G	39	28
17	Iowa Army Ammo Plant	619304	71	C	19	13
18	Longhorn Army Ammo Plant	572197	65	C	65	42
19	Watervliet Arsenal	570620	65	G	35	23
20	Tooele Army Depot	538745	62	G	21	13
21	Lima Army Tank Plant	476480	54	C	57	31
22	Letterkenny Army Depot	465991	53	G	47	25
23	New Cumberland Army Depot	445310	51	G	61	31
24	Scranton Army Ammo Plant	426246	49	C	42	20
25	Corpus Christi Army Depot	382044	44	G	—	—
26	McAlister Army Ammo Plant	339480	39	G	57	22
27	Dugway Proving Ground	320519	37	G	15	5
28	Sacramento Army Depot	243054	28	G	62	17

AMC Rank	Installation Name	Total MBTU/yr	Energy Mbtu/hr	Operator G or C	Process %Pro. Eng	Energy MBtu/Hr
29	Twin Cities Army Ammo Plant	234763	27	C	8	2
30	Joliet Army Ammo Plant	232831	27	C	—	—
31	Milan Army Ammo Plant	221662	25	C	44	11
32	Harry Diamond Lab	220041	25	G	44	11
33	Hawthorne Army Ammo Plant	217319	25	C	48	12
34	Lexington Bluegrass Army Depot	195845	22	G	19	4
35	Kansas Army Ammo Plant	195731	22	C	49	11
36	Pueblo Depot Activity	165994	19	G	—	—
37	Seneca Army Depot	164946	19	G	42	8
38	Rocky Mountain Arsenal	157631	18	G	—	—
39	Vint Hill Farms Station	151275	17	G	—	—
40	USA Natick RD & E Center	148997	17	G	24	4
41	Cameron Station	148435	17	G	—	—
42	Indiana Army Ammo Plant	139164	16	C	48	8
43	Sierra Army Depot	132841	15	G	26	4
44	Yuma Proving Ground	131126	15	G	54	8
45	Louisiana Army Ammo Plant	124905	14	C	75	11
46	Savannah Depot Activity	122847	14	G	8	1
47	Sunflower Army Ammo Plant	116386	13	C	67	9
48	Materials Technology Lab	108611	12	G	—	—
49	Riverbank Army Ammo Plant	90012	10	C	34	3
50	Mississippi Army Ammo Plant	82040	9	C	—	—
51	Badger Army Ammo Plant	75310	9	C	—	—
52	Newport Army Ammo Plant	67660	8	C	8	1
53	Ravenna Army Ammo Plant	62089	7	C	41	3
54	Jefferson Proving Ground	60447	7	G	16	1
55	Umatilla Depot Activity	30499	3	G	—	—
56	St. Louis Army Ammo Plant	17649	2	C	—	—
57	Fort Wingate Depot Activity	16780	2	G	—	—
58	Volunteer Army Ammo Plant	13485	2	C	80	1
59	Cornhusker Army Ammo Plant	3178	0	C	—	—
60	Sharpe Army Depot	0	0	G	—	—
	1992 AMC Total	25613698	2924			
	1992 AMC Bases With Process Energy Estimates				45	1172

Energy Management Analysis Conducted by IDA

The Office of the Assistant Secretary of Defense (Production and Logistics) has tasked the Institute for Defense Analyses (IDA) to study costs and benefits of energy management practices of DOD process facilities. Their first task was to define the term "process facilities," which was defined as the entire group of facilities that report process energy in the Defense Energy Information System's Utility Energy Reporting System (DEIS). In FY91, the process energy reported in DEIS-II totaled \$278 million.

It was divided among the following categories: (1) Air Force Logistics Center, (2) Navy Shipyards, (3) other Navy industrial facilities, primarily reserve industrial plants, (4) Arnold Air Force Station, (5) Army ammunition plants and (6) other disparate installations with small process energy consumption. Using the DEIS-II database, the focus was narrowed to some 90 facilities worldwide. To allow in-depth analysis, the focus was further narrowed to a small sample of four facilities: (1) Oklahoma City Air Force Air Logistics Center, (2) Puget Sound Naval Shipyard, (3) Arnold Engineering Development Center, and (4) Holston Army Ammunition Plant. These sites were selected after consultation with Headquarters staffs of the three service branches. This sample was determined to be small enough to allow in-depth analysis, but also large enough to include representatives of most of the important classes of facilities.

Each of the case studies consisted of an overview of the facility's mission, a description of data sources, estimates of the energy consumption profile, estimates of the immediate outlook for energy cost savings projects, and a summary of the salient points learned at each facility. The main findings were that:

1. IDA projected that a 20 percent reduction in energy cost, relative to FY91 levels, was technically possible and economically justifiable.
2. Smaller projects hold more promise than larger ones for immediate, relatively cheap cost reductions. (It seems generally true that small projects yield higher returns.)
3. Some of the most interesting developments in industrial energy conservation are in the areas of organization and information.

It appears that the technical expertise already existed in the organization to identify and develop economically viable projects. However, the Department did not have an organizational structure that encouraged teamwork between the energy managers and the production personnel, or that widely disseminated adequately detailed information on energy consumption and costs to operators. IDA believes one root cause of these institutional difficulties is the lack of an incentive structure that rewards the actual operators and decisionmakers for energy conservation. Institutional misalignments are a major obstacle to rational energy management. IDA also believes that changes to the process-servicing utilities, such as steam and compressed air, may be the most fruitful place for energy managers to look for energy cost reductions.

3 Army Industrial Facilities Review

To better understand the Army industrial facilities, industrial operations were reviewed at three large energy-consuming AMC installations: Holston Army Ammunition Plant (HAAP), Rock Island Arsenal (RIA) and Aberdeen Proving Ground (APG). The activities at these three sites cover almost all the major Defense industrial operations. In addition, APG was visited because it is currently the largest energy user among the AMC installations. Furthermore, the Army Environmental Center (AEC) is located at APG, and it was necessary to obtain the air emission inventory reports from AEC. Coincidentally, IDA had selected HAAP as the representative Army site for their Defense process energy management study and the visit schedule fit with the schedule for this study; no additional payment was needed to cover the Contractor's time charge. The visit to RIA was recommended by the Facilities Operations Chief of AMCCOM, which is also located at RIA.

Site Visit at Holston Army Ammunition Plant

Millard Carr, of the Office of the Deputy Undersecretary of Defense, Environmental Security, Conservation and Installations has been active in energy matters for several years. Mr. Carr had retained IDA for a preliminary study of energy consumption in industrial operations in DOD. Dan Utech of IDA and Jeri Northrup, of USACERL, were to visit Holston Army Ammunition Plant from 1 to 4 March 1994 as the one Army installation to be included in the study. Meetings were held at HAAP with Scott Shelton, contracting, and Jerry Bouchillon, energy specialist, of the contractor staff.

Plant information was collected by interviewing Mr. Bouchillon and Mr. Shelton. There was no audit other than the interviews. An inspection tour was conducted in the morning of the first day. The rest of the 2.5-day site visit was spent in conference collecting pertinent data by interview.

Safety is the primary concern in plant operations. It appeared that many energy conservation opportunities are not considered because conservation processes are not well understood and there is some apprehension that any change in operations may result in unsafe conditions. The contractor, Eastman Corporation, runs the plant on a cost plus profit basis, with a profit of about \$4 million per year. The contractor is not

compensated for energy savings and has no financial incentive to institute changes in operation.

The following specific problems were found:

1. The 700 ton/day capacity plant produces around 20 ton/day of explosives. Glacial acetic acid is produced in one of the sections of the plant compound and transferred to another. The buildings are placed at great distances apart and barriers are added for safety. This geometry requires long runs of steam from the central steam plant.
2. Two 125,000-lb per hour steam boilers are run at 55 percent efficiency; about 20 percent of the steam produced is wasted in leaks and dumps. As is the case at many Army sites, new equipment was installed, but has never been used. For example, an installed pulverized coal boiler has never been used. Steam pressure is reduced from 400 to 70 lb for the processes in one area and from 300 to 35 lb in another. No apparent need for the high pressure steam was found. The repair of steam leaks is the contractor's responsibility, but there is no group designated to do this.
3. Steam is used for increasing the process temperature, but there may be other, possibly more efficient ways to achieve the desired effect. A condensate polishing system is being installed at one section of a plant where condensate is being dumped. Some new above ground steam lines are being installed in production lines that are shut down. There are 13 meters, but they are not being read.
4. Central air compressors are common and they are reported to have great losses. Leaky air lines are known to be significant energy sinks. Currently funded projects may not show monetary savings because the production lines affected are or may be slated for shutdown in the near future.
5. As with other installations, the change from steam power to electric is ongoing. Presently, electricity supplies 5.6 percent of the energy and represents 27 percent of the energy bill. This may increase as air conditioning and new office space are added.
6. Many technical decisions are made that affect industrial processes without data to back them up. For example, when asked to verify the assumption that the HMX (high melting explosive) uses 5 times more energy to make than RDX (research development explosive), the response was that "no data was available." A more detailed evaluation of plant operation to identify energy and pollution reduction opportunities appears to be justified.

Site Visit at Rock Island Arsenal

The visit to Rock Island Arsenal was recommended by Mr. Sabah Issa, Chief, Facilities Operation, AMCCOM and was coordinated through Mr. Robert Burchett, Energy Coordinator, AMCCOM. A planning meeting convened earlier at SAIC's McLean, VA offices on 1 March 1994, involving USACERL, AMCCOM, AMC/HQ, DOD and contractors with capabilities in industrial process energy evaluations and air emissions work, identified an approach that included some initial site visits. The plan for the 5 April 1994 site visit was to obtain sufficient information on the most broadly used processes that also have significant energy and air emissions impacts, develop energy-saving/air emission reduction strategies for these processes, and put the information into a tool that could be used by installation personnel to identify and quantify these opportunities. Among the processes under consideration were:

- chemical production
- heat treating
- machining and metal working
- plating
- painting
- solvent cleaning and degreasing
- central heating/cooling
- incineration
- utility systems
- controlled atmosphere testing.

The specific objectives of the Rock Island Arsenal (RIA) visit were to:

1. Familiarize the team with the kinds of industrial processes likely to be encountered in Army installations of this type
2. Determine whether the processes at this installation could be considered "typical" or representative to a sufficient degree to provide a basis for procedures to be embedded in a proposed PEPR tool
3. Meet with Mr. Bob Burchett and other AMC staff at RIA to identify additional sites that should be evaluated for process energy reduction and pollution prevention opportunities.

Production Plant Review

Rock Island Arsenal has state-of-the-art manufacturing capabilities geared toward the production of products such as howitzers, gun mounts, small arms, grenade launchers, and associated parts. It offers complete production capabilities—from a foundry/

forging operation through welding and machining, and finishing and assembly. Most of these production operations have been consolidated under one roof over the past few years in the Major Charles B. Kingsbury Manufacturing Center, reported to be the world's largest government manufacturing facility. It represents a \$220 million investment on the part of the government under the Renovation of Armament Manufacturing (REARM) project. The center also serves as a training institute for local industrial firms and colleges.

A guided tour of the center was arranged by Mr. Bob Burchett. Also accompanying the project team on the tour were Mr. David Osborn, RIA's Energy Coordinator, and a tour guide. The specific production areas/processes visited were as follows:

World War I Wing—Tank and Carriage Assembly Plant. This wing is the oldest structure within the Kingsbury Center, and houses a variety of operations. Included are numerically-controlled design and production tools. Tolerances can be maintained to approximately 0.003 in. on average using state-of-the-art laser technology. Inspections are also automated. The advanced automation methods such as the robotic live tooling lathe cell, enables two people to control a whole group of machines. The machines do the combined work of turning (lathe), milling, drilling, and tapping. Everything is designed to minimize the movement of material and human error. Statistical process control is built in. In addition to the manufacture of recoil mechanisms, gun mounts, and towed-howitzer assemblies, the wing also makes rubber and plastic moldings, and houses nondestructive evaluation (NDE) equipment.

Most of the equipment is operated on a laid-away/in-place schedule owing to the nature of the typical requirements. Most operations occur over an 11-hour first shift. Due to the sporadic production requirements, and special warm-up/shut down needs of the equipment, all equipment on/off is controlled manually. Monitoring of electricity use is planned, using meters with remote read-out capability. Additionally, it was pointed out that the steam system mains are metered, as is gas use, and compressed air use. This information is fed into an energy accounting software (FASER) to aid in evaluating energy use patterns.

New Wing—Casting, Metalworking. Investment casting—a highly accurate casting method used in place of machining to manufacture howitzer kits—is performed in this building. Equipment is also available to manufacture springs. This building also houses seven axis machines and the newest computer-controlled metalworking equipment. Ultrasonic stress relief equipment is used rather than traditional heat treatment processes.

World War II Wing—Assembly and Painting. A wood block floor is the characteristic feature of this wing of the center, where machining and assembly operations, and spiral welding and bronze overlaying are done. Again, the equipment is computer operated.

The paint spray area is capable of applying chemical agent resistant coatings (CARC), a specialty process. Also within this wing, gun mounts are subjected to hydrostatic testing. The basement houses clean rooms for assembly operations that require well controlled environmental conditions. Water treatment is also accomplished here, with the water being used for a variety of purposes—washing hardware, as well as for distribution to the steam plant.

The storage/loading area has over 15,000 storage slots that can be accessed by an integrated stacker—a computerized operation that uses robotic equipment.

Plating Area. Wastewater used in plating operations is treated in a reverse-osmosis system housed in the basement. Chemicals for the plating operations are supplied by a gravity feed system. The control is automated to properly mix chemicals, achieve the correct temperatures, etc. A baghouse is used to capture particulates. A heat exchanger on the roof reclaims heat using automated controls. The entire area is kept under negative pressure to ensure that sufficient fresh air is always available. The requirements are approximately 15 air changes per hour.

Welding Shop. Most of the welding equipment uses electricity. Oxy-acetylene canisters are located outside the building for safety. Welding of parts is also done with ultrasonic equipment, and is performed automatically using computer numerical control. A 15 kW laser cutter is also used.

Foundry/Forging. The foundry uses a variety of furnaces (e.g., electric induction) to melt the various metals for casting/forging purposes. It is the only full-service DOD foundry, and has been operational for 6 years. The direct arc electric furnaces can handle up to 5 tons of material and operate at temperatures of 3300 °F. Samples of the slugs from these furnaces are taken periodically to check on quality.

Nonferrous metals are melted in the induction furnaces. About 22 lb of alloys can be processed in 18 minutes. These materials are used in investment casting. This is a precision casting method that results in machined-like quality at significantly lower costs. The molds for the parts are made of Furan. It was pointed out that heat recovery was also used in the foundry area.

Forging is done with hydraulic presses that can exert up to 1,000 tons of pressure; 16,000 psi hammers are also used. Robotic welders are used here and electron beam welding is also done in this building.

Current Energy Projects at Rock Island Arsenal

David Osborn reviewed the projects recently implemented or planned at RIA, and provided copies of RIA's Energy Award Nomination documents for FY91 and FY93. He also provided us with an Energy Study that had been performed in 1989 addressing buildings 208 (Heavy Gun Plant), 220 (Machine Shop), and 222 (Forge Shop). These buildings, along with the new wing, comprise the renovated manufacturing complex described above. Examples of energy efficiency projects implemented at RIA to date are:

1. Buildings
 - Increased insulation to reduce heat loss
 - Energy efficient window retrofits, including replacement of windows with double-pane units and insulated panels
 - Energy efficient lighting retrofits, including HID conversions and LED exit signs
 - High speed coil-type doors to reduce infiltration
 - Night and weekend setbacks of HVAC equipment
 - Upgraded chiller plant, including properly sized variable speed drive pumps
2. Central Heating Plant
 - Upgraded water treatment system resulting in improved heat transfer
 - Upgraded condensate system—pump replacement and steam trap program
 - Installation of oxygen trim controls
 - Variable speed drive motors
 - Valve insulation
 - Heat recovery from cooling tower water
 - Improved controls
 - Elimination of multiple boiler operation in transition months
3. Base-Wide Metering—Increase number of loads being metered. This additional information, coupled with energy management software, should help to better plan/control energy use.
4. Hydroplant Upgrades—ECIP (Energy Conservation Investment Program) modernization project will significantly increase generation capacity by up to 40 percent, reducing purchased electricity needs.

5. Process—Development and implementation of “short cycle heat treatment procedures,” which reduces the time parts must spend in a heat treatment furnace, thereby reducing energy use.

Process Energy/Pollution Reduction Opportunities

Process Equipment. Much of the equipment used at the manufacturing facility appears to be state-of-the-art. As such, equipment changeout to increase efficiency would yield little, if any benefit. For this equipment, as well as for the plant in general, operational changes (scheduling and control) would appear to be the best route towards process energy savings. However, realization of such savings would only be practical if the nature of the process operations could be modified to have a more predictable pattern. It is not obvious, based on the intermittent nature of the workflow, whether this could be accomplished.

It is possible that some of the furnaces could have efficiency upgrades (burners, controls, insulation, etc.), but gauging this potential would require more information on the specific units. The 1989 Energy Study identified several such improvements, e.g., installation of regenerative burners, seals, and special ceramic refractory coatings. However, on the basis of the site visit, it is not known whether these same furnaces are the ones still in operation nor whether these measures would prove economically attractive enough to qualify for funding.

Heat recovery appears to have some potential, although once again, more detailed information is needed. Several of the areas visited had heat recovery capabilities, although control issues and the degree to which they were used were not apparent.

Control of air emissions and treatment/disposal of process waste streams appeared to be state-of-the art, but insufficient information could be gathered to gauge this definitively.

Building Systems. Building envelope measures, including window upgrades, were already implemented or are in the works. The same is generally true of lighting system upgrades. Control of these systems and of mechanical systems was to be implemented. Current set back provisions for HVAC equipment appear to be a large energy saver.

Utility Systems. As discussed previously, the central heating plant has been upgraded recently to operate more efficiently and cleanly. There was no opportunity to visit this plant on this trip, although utility energy upgrades were a secondary purpose of this evaluation.

Conclusions

Based on the cursory examination of the manufacturing complex, and subsequent conversations with Mr. Bob Burchett and Mr. David Osborn, it appears that Rock Island Arsenal is representative of a relatively modern, energy efficient installation. While a number of operations observed at the complex are representative (plating, machining, painting, welding, etc.), they are carried out with state-of-the-art equipment in renovated space. As such, it would not be the most suitable choice for the PEPR development effort. Further consultation with AMCCOM staff is recommended to select more appropriate sites.

Site Visit at Aberdeen Proving Ground (APG) and the Army Environmental Center (AEC)

The team consisted of Mike Lin and Jeri Northrup of USACERL, and Robert Lorand and Jay Ratafia-Brown of SAIC. The team met with Lawrence Webber, who is responsible for compliance support related to air media at AEC. This visit was to investigate the extent of data collection efforts for Army Air Pollution Emission System (APES) by AEC. This database is needed for the SERDP project on energy conservation and air toxic compliance plan for DOD industrial facilities. Data for most of the AMC installations are being collected either by contractors or by base personnel. Larry Webber indicated that the air emission inventories have been completed for some installations, but would not be completed for others until summer 1994. The data collected will provide "snapshot" baseline information for comparison. Since APES does not accommodate real time operational data, it is necessary to examine ways of using the Naval Air Emission Tracking System (NAETS) program to get a more detailed picture on various process operations. The NAETS program organizes inventories and logs for the industrial source and also has many other features needed for report generation or to assist in process improvement studies. NAETS was demonstrated to Larry Webber at the conclusion of the meeting.

While at Aberdeen, the team also visited the Directorate of Public Works (DPW) of APG. NAETS was also shown to the energy and environmental staff at APG (DPW: Calvin Peake, Tom Caldwell, Steve Turner, Marty Thompson, Sandy Cormach; and Directorate of Safety, Health and Environmental: Amy Lafontaine). The software was enthusiastically received and a copy was left for the base staff to try out. This program has the possibility of interfacing with several computer programs used now for energy and environmental projects.

Note that APG is currently the largest energy user among the AMC installations. Permission for a facility visit at APG was not granted by the AMC Headquarters staff. However, discussion with base energy personnel had provided useful information in identifying major energy consuming activities at that location.

4 Review of Emission Inventory and Energy Conservation Programs

Several software programs under development at USACERL deal with energy conservation and emission inventories for DOD installations. Since these programs are applicable to DOD industrial operations, a brief review of each program is provided.

Naval Air Emission Tracking System (NAETS)

NAETS is a PC-based software package that provides detailed and timely information that environmental managers need to meet current regulatory requirements. The primary purpose of NAETS is to serve as a tool to assist source, plant, and environmental managers at the installation level.

From the mid-1970s, the Navy has lead the DOD in providing its environmental officers with computerized recordkeeping systems. That system, Naval Air Pollution Source Information System (NAPSIS) was programmed on a mainframe and required the shop level people to produce paper records followed by computer data entry by a specialist. This resulted in duplication of effort and was thus expensive in manpower costs. In the early 1990s, the Navy started another system using the latest programming technology and personal computers. This system was named the Naval Air Emissions Tracking System. (The Navy had planned other tracking systems for water, solid waste, and tanks, which they have produced concurrent with NAETS.) USACERL was contracted by the Navy to produce NAETS. The USACERL designers saw a need to centralize data entry so NAETS was programmed with that in mind. To meet information requirements of the wide variety of air pollution sources that might exist at an installation, the system is designed with modules for each emission source such as plating, painting, and boilers. Since the source modules need to share common information, each module is linked to common independent databases through a supervisory operating system. The NAETS system contains a source inventory (including technical information describing each source), detailed information about the emissions and the permits needed for each source, information concerning notices of violation, source inspections information, emission calculations,

compliance agreements, control measures, impact studies and cost analyses, alarms, regulations, and permit forms.

As the software evolved, USACERL found innovative ways to produce better products. Two of the additional programs that were produced were the data dictionary that classifies all the data items and an advanced units conversion program. The Defense Department has officially converted to the metric system, and the units conversion abilities of NAETS makes this easy.

NAETS' modular construction makes it flexible and expandable. From a cursory glance there appears to be much extraneous information gathered, but much of the information is used in other modules of the program that make NAETS useful as a management tool, rather than just an emissions calculation program. The user friendly program, like most modern software, promotes three dimensional thought. The user can find and manipulate needed information with ease. The Point of Contact (POC) for the NAETS program at USACERL is Ralph Moshage. POC at Naval Facility Engineering Service Center (NFESC) is Connie Pennington. In August 1994, Ralph Moshage and Connie Pennington presented NAETS to the Defense Environmental Corporate Information Management (DECIM) Air Media Functional Evaluation Committee. The purpose of this meeting was to develop a final recommendation on the Air Media Migratory System for all organizations in DOD. NAETS was selected to be part of the Air Media Migratory System. NAETS will function at the Shop Level while AQUIS (an Air Force System) will function at the Environmental Coordinators Level. When the recommendation is formally approved, work will begin on enhancing NAETS and AQUIS and developing an interface between the two systems.

Army Air Pollution Emission System (APES)

The Federal Clean Air Act Amendments of 1990 (CAAA) require management of a wide variety of air pollutant emissions. The Army is strongly impacted by the CAAA due to its widespread and varied operations. The Army Air Pollution Emission System (APES) program, undertaken by USACERL, contains several projects, some of which are completed, others still in progress. The first phase of the program was to provide a data entry tool for the compilation of Army emission data by commercial vendors contracted by the Army to catalog the major Army installations. The second phase of the program is to expand the data entry system into a full management system. The full system will promote compliance with the CAAA, automate recordkeeping for air emissions, provide management tracking and decision tools for all levels of air pollutant management, and automate Emission Factor calculations for the majority of the Army emission sources. The preliminary system for contractor data entry has been

released. Six APES inventory reports were provided by Mr. Webber of AEC, from Watervliet Arsenal and five Army Ammunition plants (Lone Star, Iowa, Milan, Holston, and Radford).

Renewables and Energy Efficiency Planning (REEP)

The Renewables and Energy Efficiency Planning (REEP) program provides the means to assess the economic potential for investment in energy efficiency and renewable resource technologies. The USACERL-developed REEP program can be used to analyze the energy, environmental, and economic impacts of retrofit projects for 240 DOD facilities. REEP uses relatively simple algorithms in conjunction with installation-specific data to estimate the energy conservation potential for entire installations. It provides monetary social benefits of avoided pollution due to conservation initiatives. The program models 78 energy and water conservation opportunities, and has eight basic categories of opportunities: (1) electrical, (2) lighting, (3) building envelope, (4) HVAC, (5) water, (6) utilities, (7) renewables, and (8) miscellaneous. REEP was developed using Microsoft FoxPro Version 2.5 for Windows. The financial portion of REEP performs an economic analysis resulting in simple payback, savings-to-investment ratio, adjusted internal rate of return, and a discounted life-cycle cost analysis based on Title 10 of the Code of Federal regulations, Part 436. Budget analysts can use the program to develop a long-term economic investment strategy to maximize the benefits of limited capital from energy conservation projects. REEP is an ideal tool for providing a broad overview of energy savings potential and associated economics at an installation level and for optimizing energy, financial, or pollution variables. The USACERL POC is Mr. Robert Nemeth.

5 Characterization of Heavy Metal Air Toxic Sources

Identification and characterization of potential metal air toxic emission sources are the initial steps to be taken in studying the emissions problems. Appendix A includes a summary of the literature search on heavy metal pollutant sources. Among the 189 air toxics, eleven high priority metals were found to be of concern, including Antimony (Sb), Arsenic (As), Beryllium (Be), Cadmium (Cd), Chromium (Cr), Cobalt (Co), Lead (Pb), Manganese (Mn), Mercury (Hg), Nickel (Ni), and Selenium (Se). Table A3 lists the major industrial sources emitting these metals. It was recommended that:

1. A detailed description of the DOD facilities that discharge metals into the atmosphere should be compiled
2. Several typical facilities (e.g., plating, painting, welding, machining shops, central heating plants) should be identified with the intent of implementing a sampling program
3. The sampling results should be evaluated to permit USACERL to ascertain if other facilities should be included in a broader scope or in a more detailed individual program
4. Research into indoor air quality remains as one of the most important environmental programs, and USACERL shall begin a concerted effort in this area.

6 Watervliet Arsenal Plating Process Study

It was recognized in the planning stage of this project that the PEPR program would need an accurate source of input data. In an effort to find sources, the Army Environmental Center was contacted because they are conducting air emission inventories for the majority of the Army installations. Due to the "snapshot" nature of the data, this source was judged to be inadequate to meet current needs. Generating a second software program to collect and organize the data was considered to be too expensive and time consuming. However, NAETS provided many of the needed functions for this task. Also, it was found that Watervliet Arsenal was interested in field testing the NAETS program. Hence, it was mutually beneficial to provide partial funding to customize the NAETS program plating module and to use it to collect plating shop data to validate the PEPR plating process.

The NAETS program includes inventories of materials and equipment. It has logging capability and history files as well as a units conversion utility. NAETS organizes information concerning the materials and tracks them in shops and waste streams. Since plating is a process that has high toxic emissions and energy consumption, it was an ideal choice for this study. Watervliet Arsenal agreed to assist in collecting the information for this project.

Plating Shops Information

Watervliet Arsenal has several plating facilities. The operation uses hazardous materials to complete the mission. Scrubber systems are required to meet OSHA and environmental laws. These systems will be upgraded to include continuous monitoring. NAETS is used to track and monitor the use of the material required. Watervliet's goal is to achieve zero-discharge systems; in fact, the Arsenal has designed a new plating line aimed at achieving this goal.

Plating is done in several discrete steps. In electroplating, an electrical charge is passed through a metal ion solution using the object to be plated as part of the circuit. The process produces a thin surface coating of one metal on another by electro-deposition. This surface coating is typically used as a corrosion protection, as resistance to wear caused by water or erosion, for antifrictional properties, or for

decorative purposes. The electroplating of common metals includes the processes in which ferrous or nonferrous base material is coated with copper, nickel, chromium, brass, bronze, zinc, tin, lead, cadmium, iron, aluminum or combinations thereof. Precious metal electroplating includes overlays of gold, silver, palladium, platinum, rhodium, indium, ruthenium, iridium, osmium, or combinations of these metals.

Electroless plating is an auto-catalytic chemical reduction process that depends on the reduction of a metallic ion in an aqueous solution containing a reducing agent. The subsequent deposition of metal occurs without the use of external electrical energy. Electroless plating provides a uniform plating thickness on all areas of the part regardless of the configuration or geometry of the part. An electroless plate on a properly prepared surface is dense and virtually nonporous.

Immersion plating is a chemical plating process in which a thin metal deposit is obtained by chemical displacement of the basis metal. A metal will displace from solution any other metal that is below it in the electromotive series of elements. This process is not autocatalytic. Chemical conversion coating uses a phosphating solution on steel. Anodizing of aluminum, magnesium, zinc, and titanium is achieved by dipping the metal in dilute sulfuric acid or dilute chromic acid solution. A layer of the plating material forms on the surface.

Etching and chemical milling are processes for taking very thin layers of material off the part. Etching is done with chemical reagents, etchants, and an ion beam. This process is used to produce a very bright finish or to produce a surface for study of the metal. Passivation is a form of etching where iron particles are removed from stainless steel and a coating of tin oxide is layered on the surface.

Process Flow in Most Shops

Disassembly takes place both in the shop and before shipment to the plating shop. Parts are tagged and sent to the proper area to be processed. Parts must be cleaned of all oil, grease, and dirt from the basic material. In the past, acids and alkaline solutions were commonly used to clean the parts before plating. Water, detergents, and other dispersing agents are now the cleaners of choice. The solution tanks are maintained by the chemist.

Mechanical plating operations include barrel processing and automatic dip vats. Barrel processing is applied to small component parts that would be difficult or uneconomical to plate conventionally. There are two general types of barrel processing. The first uses an open-ended barrel unit that contains the component

parts and plating solution. The parts and solution are rotated together at an angle to complete the plating process. The second, more modern type of barrel plating uses a totally enclosed, submersible barrel driven by a belt or gear system from above the plating solution. Both of these barrel systems allow for free movement of the component parts when the barrel is rotated.

The tank-type plating uses racks or hangers that go manually from tank to tank. This can be automated by conveyors that use hangers and racks. Typical time for plating is one to several hours. Figure 3 shows the typical electroplating flow diagram.

In electroplating, the emissions are formed by the electrical current disassociating the water at the cathode and anode, and forming gas bubbles. The bubbles burst at the surface scattering a fine mist. The emissions are controlled by several methods, one being a ventilation system. Other methods are used as well, such as plastic balls floating on the surface of the tank, chemical suppressants, foam blankets, and wetting agents. Wetting agents reduce surface tension, thereby reducing mist formation. When combined with a layer of foam, wetting agents provide the added protection of allowing the hydrogen and oxygen gases to reform into water. The mist is considered a particulate pollutant rather than a gas or vapor because it contains aerosols.

Plating Data Needs

Software designed primarily as a management tool for plating processes must include a number of general categories, such as specific work accomplished (usually logs), the material needed to complete the task, and inventory and costs of the equipment. Depending on the plating operation, there may also be information required by a chemist who tests and calibrates the solutions of the baths.

For the software to be useful to the environmentalist, it must log information that correlates to the permits and regulations governing the operation. These regulations are currently being created for plating. Hard chrome plating was the first plating process to be covered by the USEPA. Some of the monitoring required by the regulations are: measuring the gas velocity of inlet stream to the control device once per day, measuring concentration of chromic acid in scrubber water if a packed bed scrubber is used, recording performance of washdown of the packed bed or mesh pad, and measuring and recording pressure drop across the device. Emissions have not been tracked by many plating shops in the past so the measurement equipment is not available. Thus, the USEPA has designed methods for estimating and reporting the required information.

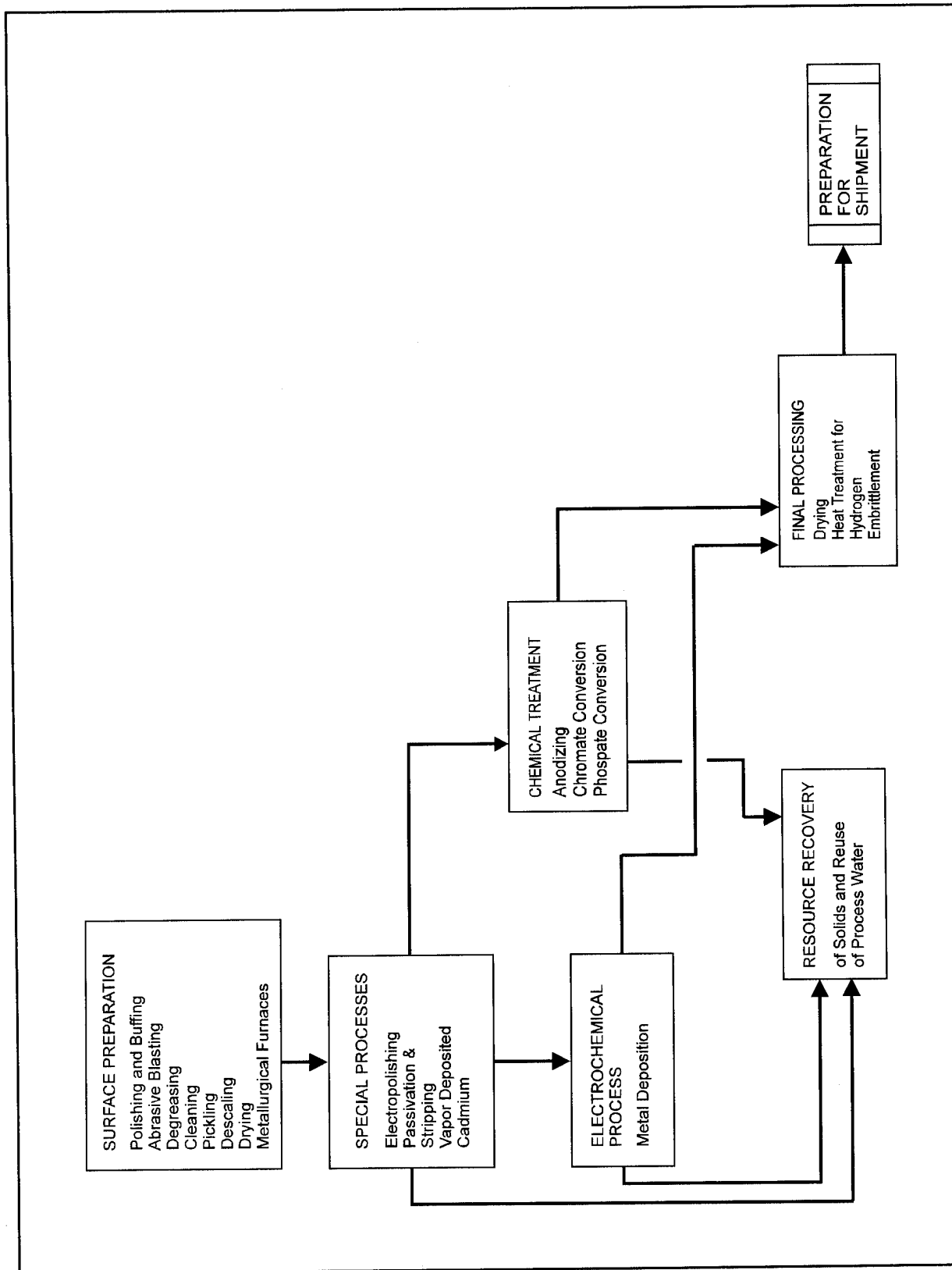

Figure 3. Typical electroplating flow diagram for work.

Current Data Collection and Reduction

The data that is collected now at the shop level addresses what is required for the regulations in place and what is needed for shop management. The regulations for chrome plating were minimal and had been assigned to the environmental offices. The environmental personnel would go to the shop and request the logs for chemistry changes and vat dumps to show that they were within the correct limits. This information was usually in the form of paper logs that had to be entered into a spreadsheet for reduction. This process allowed for errors at both the shop and the environmental office.

Future Data Collection Needs

Since State environmental offices were initiating chrome recordkeeping for air pollution, the need for computer-based log keeping was apparent before the USEPA promulgated the law to control chrome air emissions. Work done by the U.S. Navy in California has served as a guide for the USEPA regulation on chrome and for the NAETS program. Some of the recordkeeping that was required by the new regulation was already implemented in NAETS.

Database Development for NAETS Plating Module

NAETS is a system based on defined work processes. As such, the designers have predetermined how the information will be arranged in the program. The program is organized to include a static and a dynamic area as well as information about inventory and materials. Other sections are points of contact, unit conversion and the reports. The reports are both management and air emissions reports. Although there are many static items that will interest some and not others, it was felt that the program should have the widest application.

NAETS is written in FoxPro 2.6, a fully relational data base management system. The program requires a minimum 486 PC-compatible computer with a minimum hard drive capacity of 100 Mbytes. A mouse is recommended but not required. The first set of eight modules includes programs for Boilers, Dry Cleaners, Fiberglass/Composites, Plating Shops, Coating Operations, Incinerators, Cleaning/Degreasing, and Gas/Service Stations. Each of these is managed under the main NAETS Driver program. Other utilities within the NAETS driver include a Point of Contact (POC) data base, a Mail program for communications and scheduling, a Materials data base, and a

Units conversion section. Range checking, a Windows-like interface, and password control are some of the features of the software.

Plating Module Emission Factors

The emission factors are expressed in terms of weight of hexavalent chromium in milligrams (mg) divided by the electrical input in ampere-hours (current applied multiplied by time duration of the operation) times 10^{-9} , times an emission factor. If the information is not available for these calculations, the tank surface area is used with an emission factor. A third method to calculate the emissions is available in this program: a pick box of typical values is supplied for the user. This information is included in the NAETS Users Guide and the Technical Reference for Plating Module.

Materials Data Base

When entering the program, the user sees a list of materials (if any) that have been added previously. The user can elect to add or delete materials from this list. The three items necessary to identify a material are national stock number (NSN), name, and manufacturer. These are what appear for each material in the list. The user can then use the SELECT push-button to bring up the detail screen for that material. On this screen is simply more information about the selected material. From this, the user can provide a "list of approved users" and add constituents for each material. This database will be checked by each of the source's inventories to determine which materials in the materials database are approved for use at the source. On-hand inventory is limited and waste is avoided when these records are kept accurately.

Reports

Of the 37 reports available for the NAETS Plating Module, most are screen prints. The major exception is the emissions report. This report takes information in the system and calculates emissions using factors to be included in AP42 in the near future. The ability to generate additional ad-hoc reports from the information stored in NAETS was left to software packages already on the market (such as FoxPro). Report writing varies from package to package, but the format is very easy to follow.

NAETS Implementation

The management at Watervliet Arsenal set up a department to investigate advanced technologies for their industrial operations. This group has been tasked to seek out technologies that will benefit the Arsenal both monetarily and environmentally.

In the past year, the DOD has begun to track environmental fines at the Chief of Staff level. Now environmental issues are evaluated by both the regulatory standards and costs. Members of the Advanced Technology Team are familiar with computers and understand their advantages and weaknesses. Although they had already had a contract for a software program to track hazardous materials from purchase to disposal, they recognized the need for computer tracking of information that was kept in log books at the plating shop and wastewater plant. They agreed to review NAETS to see if it could be used at their installation. Managers of all involved departments (Advance technology, Engineering, Environmental, Plating, Wastewater) agreed to a trial. The trial would start with Plating. The plating shop would be given hardware and software that had been recommended for the Navy. The information from existing log books would first be entered into the system. It was agreed that after the shop manager was trained and had used the system for 2 months, an evaluation would be made of the program. Two thousand dollars would be set aside for making recommended changes in software.

Watervliet Arsenal has two large plating facilities. One is used for large items (the "majors"), the other can accommodate smaller items (the "minors"). The NAETS program allows the user to split up shops in this way although other structures are possible.

The information related to each shop has been kept in log books. The subjects of the log books are: Solid Waste Collection, Testing Records, Adjustment of Solutions, and Electro-Clean Analysis. Other items tracked by the program include formulas, inventory, and points of contact. NAETS was designed so that all of the information need not be input into the system if the source manager does not need it or is not able to invest the time for entry.

Data collection is both labor intensive and time consuming. Many people must be contacted to get information. This is why NAETS was so well received by the environmentalist. They did not have the information they needed and neither did the managers for the pollution source. When the information for a permit was aggregated, there was no organized way to store and retrieve the information for future use in other forms, permits or reports. NAETS fulfills this need.

Hardware

The hardware used was a 386 IBM-compatible PC with a mouse. This machine was not quite adequate to keep multiple copies of the program and data. The environment that it was placed into was harsh. The room was not air conditioned and particulate in the form of oily whisker-like filaments were on the air intake of the computer after one month. The room was air-conditioned 5 weeks after the installation. There did not seem to be any problems other than the machine being very slow. This would be an impediment for manipulating massive amounts of data and is an irritant for the operator. More advanced computer hardware is preferred for this task.

Methodology of Instruction

The NAETS plating module was installed on the computer for the shop. In 2 weeks of one-to-one training sessions, the trainer and the manager worked out the shop information entry in the program. When installing the program at Watervliet, paper logs were matched to the logs in the program. USACERL personnel collected information from various offices at the Arsenal and entered it into the program. Other people such as the environmental managers and the Advanced Technology Team were also trained in small groups. USACERL conferred with the users by phone several times, although the group that was trained was very quick to grasp the nuances of the program.

Evaluation of NAETS Implementation

The level of training in related information always has a direct bearing on the speed of the student to learn new material. In this task, all of the people that were to be instructed in the use of NAETS were computer literate. Most had worked with main-frame programs that are often more difficult to learn and use than the new menu-driven programs like NAETS. This meant that training this group was fairly easy. There were few occasions where material had to be repeated. The students already had most of the language or jargon that was specific to this program because the program designers tried to keep the vocabulary the same as typically used in shops. The NAETS plating module would be much more difficult to transfer to a group of people that were not acquainted with plating shops or environmental regulations.

Because the screens and information contained in the program are interconnected and used repeatedly, care must be taken to keep the operator from using an area of the program for something other than what the designers intended. For example, the

requirements engineer at Watervliet broke out the information concerning a plating device from the plating tanks. Watervliet did not have a plating device so the manager decided to use that part of the program for standard recipes for the tanks. Later, this database was used for the pick list in another area of the program. This pick list showed up with invalid information on it. USACERL added a new section for the standard starting formulas of the tanks to another part of the program. The design engineers had decided that there was no need for that kind of information in the original design because in the Navy a chemist would usually have this kind of information in another program.

New users expressed overwhelmingly favorable opinions of NAETS. The information that had previously been logged on paper was in the program. The change in the format is sometimes disconcerting, but to structure the information to appear as on their paper copy would require major changes to the program structure. For those who understand the program, this is a minor inconvenience.

7 Process Energy and Pollution Reduction Level I Analysis

To facilitate the development of the PEPR analysis tool, an energy/emission review was conducted at Pine Bluff Arsenal in Pine Bluff, AK. With full cooperation of the base production personnel and energy coordinators, a 1-day workshop was conducted, followed by a 3-day Level-I energy and emission review. A preliminary report summarizing the results of the audit was prepared and sent to the Arsenal for review. The Director of Environmental Management at Pine Bluff Arsenal gave the program a favorable review (Appendix B). The review results at Pine Bluff Arsenal are presented below.

Energy and Emission Review at Pine Bluff Arsenal

A 3-day Level I Process Review was sponsored by USACERL from 21 to 24 June 1994 under the Strategic Environmental Research and Development Program (SERDP) to analyze potential process improvements in the manufacturing operations of Pine Bluff Arsenal (PBA). Many opportunities were identified to improve energy efficiency, environmental impact, and other important manufacturing cost issues. The review team consisted of (Pine Bluff Arsenal personnel) Tony Davenport, Allen DeHagan, Charlie Neel, Nancy Rimmer, Randy Rosenwinkel, Steve Still, Philip Vick; (USACERL personnel) Mike Lin and Jeri Northrup; (Science Applications International Corporation [SAIC] personnel) Malcom Fraser and Robert Lorand; (Energy Technology Services International personnel) Walter Smith, Robert Erickson, William Liegois.

A Level I Process Audit is a 1- to 3-day walk-through effort to identify the dollar potential for Process Improvements (P.I.) to the bottom line. Technical solutions are assumed possible and economics are approximations (40 percent). No engineering measurements are made. A Level I with significant promise would normally be followed by a Level II Process Audit to verify level I assumptions and fully develop the ideas from the level I screening analysis. Table 2 shows details on achieving process optimization via process change.

Table 2. Achieving process optimization through process change.

Description	Level I	Level II
Objective	Determine economic "potential" from process improvements	Further development and evaluation of leading process improvement ideas
Assumptions	All solutions are technically and economically viable	Verify all critical technical and economic assumptions
Data	Observations by experts	Hard data measurements
Techniques	OLBs, BPF, WA, S.L.G., HWD	Extension of same with more depth and accuracy
Technology	Rely on site personnel	Intensive technology search
Calculations	Guesses and estimates	More accuracy and precision
Economics	Approximations ($\pm 40\%$)	More accurate ($\pm 15\%$)
Documentation	Memo report	Comprehensive report
Cost	\$5,000 – \$20,000	\$20,000 – \$200,000
Savings	1 – 5% of mfg. costs	5 – 20% of mfg. costs
Final Action	Proceed with Level I (or not)	Plant test process changes and verify results

This Level I effort found that potential exists to reduce the PBA manufacturing costs by a minimum of \$28 million Net Present Value (NPV) (Table 3) over a 10-year period by aggressively pursuing a concerted effort in process optimization. This conservative estimate amounts to a 1 to 4 million dollar savings per year (1 to 4 percent of the current \$100 million annual operating budget) phased in over a 1- to 10-year period. Details and basis of this bottom line dollar contribution are presented below in **Facility Cost Structure Evaluating Value** (p 49) and **Estimating Dollar Benefits** (p 72). From process improvements, annual savings based on the Level I assessments are \$900,000, or 30 percent of energy costs, \$800,000 or 20 percent of environmental operating costs and \$2,500,000 or 5 percent of operating labor costs. Clearly, the potential exists to significantly reduce manufacturing costs by aggressively pursuing process optimization. The opportunity exists to significantly expand this dollar contribution by recognizing the labor savings possible from process improvements.

The initial phase, establishing value, was to estimate the potential dollar contribution from process improvements in high cost areas. This required determining the site operating cost structure for purchased energy (Tables 4 and 5). The next steps were to analyze existing process energy use (One-Line Energy Balances, Figures 4 and 5), target areas for process improvement, quantify energy efficiencies, and analyze the strength and weakness of the current process. Selected process steps were then identified for further evaluation in critical cost areas such as reduced environmental impact, increased energy performance, and improved readiness.

Table 3. Estimating dollar benefits for P.B.A. based on a level I analysis.

Operating Budget (Current Yr., Mil. \$)	1994	1995	1996	1997	1998	1999	2000	2001	2002	2003
<i>Base case (without P.E.P.R.): assumes a 5% annual escalation in costs</i>										
Energy	3.3									
Environment	6.0									
Capital	8.2									
Total (1)	17.5	18.4	19.3	20.3	21.3	22.4	23.5	24.6	25.8	27.1
<i>Alternative (with P.E.P.R.): assumes no escalation because of process improvements</i>										
Energy	3.3									
Environment	6.0									
Capital	8.2									
Total (2)	17.5	17.5	17.5	17.5	17.5	17.5	17.5	17.5	17.5	17.5
<i>Avoided Cost</i>										
With P.E.P.R.										
Total (1-2)	0	0.9	1.8	2.8	3.8	4.9	6.0	7.1	8.3	9.6
<i>Net Present Value</i>										
@ 7% Discount Rate	0	0.84	1.56	2.25	2.80	3.35	3.90	4.30	4.63	4.80
<i>Sum of 10 Yr. NPV = \$28.4 Million</i>										

Table 4. Electrical consumption and cost.

Month	Demand kW	Entry A & B Consumption kWh	Cost (\$)	Demand kW	Entry C Consumption kWh	Cost (\$)	Demand kW	Total A, B, C Consumption kWh	Cost (\$)	Ave. Cost \$/kWh
May '93	1,958	677,754	48,213.54	3,044	989,832	69,406.01	5,002	1,667,586	117,619.55	0.070533
June	2,456	1,176,714	76,244.23	2,964	1,308,384	80,685.93	5,420	2,485,098	156,930.16	0.063148
July	2,646	1,072,764	72,124.95	4,375	1,574,496	109,631.10	7,021	2,647,260	181,756.05	0.068658
August	2,646	1,360,049	84,982.40	4,193	1,884,960	121,963.30	6,839	3,245,009	206,945.70	0.063774
Sept	3,110	1,288,980	75,407.40	3,568	1,075,536	69,466.67	6,678	2,364,516	144,874.07	0.061270
Oct	2,460	875,952	52,282.39	2,379	1,009,008	52,104.27	4,839	1,884,960	104,386.66	0.055379
Nov	1,894	792,036	41,950.82	2,621	986,832	55,094.77	4,515	1,778,868	97,045.59	0.054555
Dec	1,814	759,528	41,351.10	2,681	1,064,448	57,123.31	4,495	1,823,976	98,474.41	0.053989
Jan '94	1,885	909,216	45,944.13	1,885	1,175,328	58,334.75	3,770	2,084,544	104,278.88	0.050025
Feb	2,051	862,092	43,408.56	2,722	1,075,536	53,466.72	4,773	1,937,628	96,875.28	0.049997
Mar	2,051	961,884	47,326.81	2,157	989,832	47,477.88	4,208	1,951,716	94,804.69	0.048575
Apr	1,920	931,392	47,087.68	2,984	1,164,240	60,577.69	4,904	2,095,632	107,665.37	0.051376
Total:		11,668,361	676,324.01		14,298,432	835,332.40		25,966,793	1,511,656.41	
Average cost; \$/kWh						0.058421259			0.0582149829	0.057607

Table 5. Natural gas consumption and cost.

Month	Consumption (MMBTU)	Cost (\$)	\$/MMBTU
May '93	37,722	117,890.57	3.13
June	31,285	100,008.33	3.20
July	31,064	99,689.69	3.21
August	33,092	104,343.74	3.15
Sept	31,814	100,821.49	3.17
Oct	35,586	104,731.81	2.94
Nov	52,934	161,904.58	3.06
Dec	61,307	182,230.73	2.97
Jan '94	68,069	206,448.27	3.03
Feb	62,028	189,703.94	3.06
Mar	58,691	180,453.51	3.07
Apr	42,066	134,299.21	3.19
Total:	545,658	1,682,525.87	3.08

The Process Review used brain storming techniques to create a new process by modifying the existing (old) process. The existing process was challenged, and new practices and new technologies were considered. Forty-five ideas were generated for the White Phosphorous Plant, more than 40 ideas were generated for the Red Phosphorous Plant, and 34 ideas were generated for improvements in the Central Energy and Environmental Systems. A Level II study would analyze the economics of these 100 process improvements.

Clearly, many process improvements with considerable bottom line benefit were identified by the Process Review Team. Some of these can be accomplished with minimal investment and are recommended for further analysis (a Level II Study) and implementation. A Level II Study is typically 5 to 10 times the effort of a Level I, and it was estimated that, at PBA, the Level II study could be accomplished for \$80,000 to \$150,000 over a 6 to 10-week period, depending on scope.

Background

The success of a process review depends on the degree of involvement by site personnel on the review team. PBA actively participated as a team with USACERL representatives, resulting in a high degree of creativity and productivity. The team applied specific steps and techniques of process analysis and innovation learned during the workshop.

The review analyzed the current multistep manufacturing processes in the WP and L8A3 production areas. The initial step of a Process Review is to establish (estimate) the potential dollar value of process improvements involving energy as well as other cost categories (i.e., raw material use, capacity increases, and quality and environmental improvements).

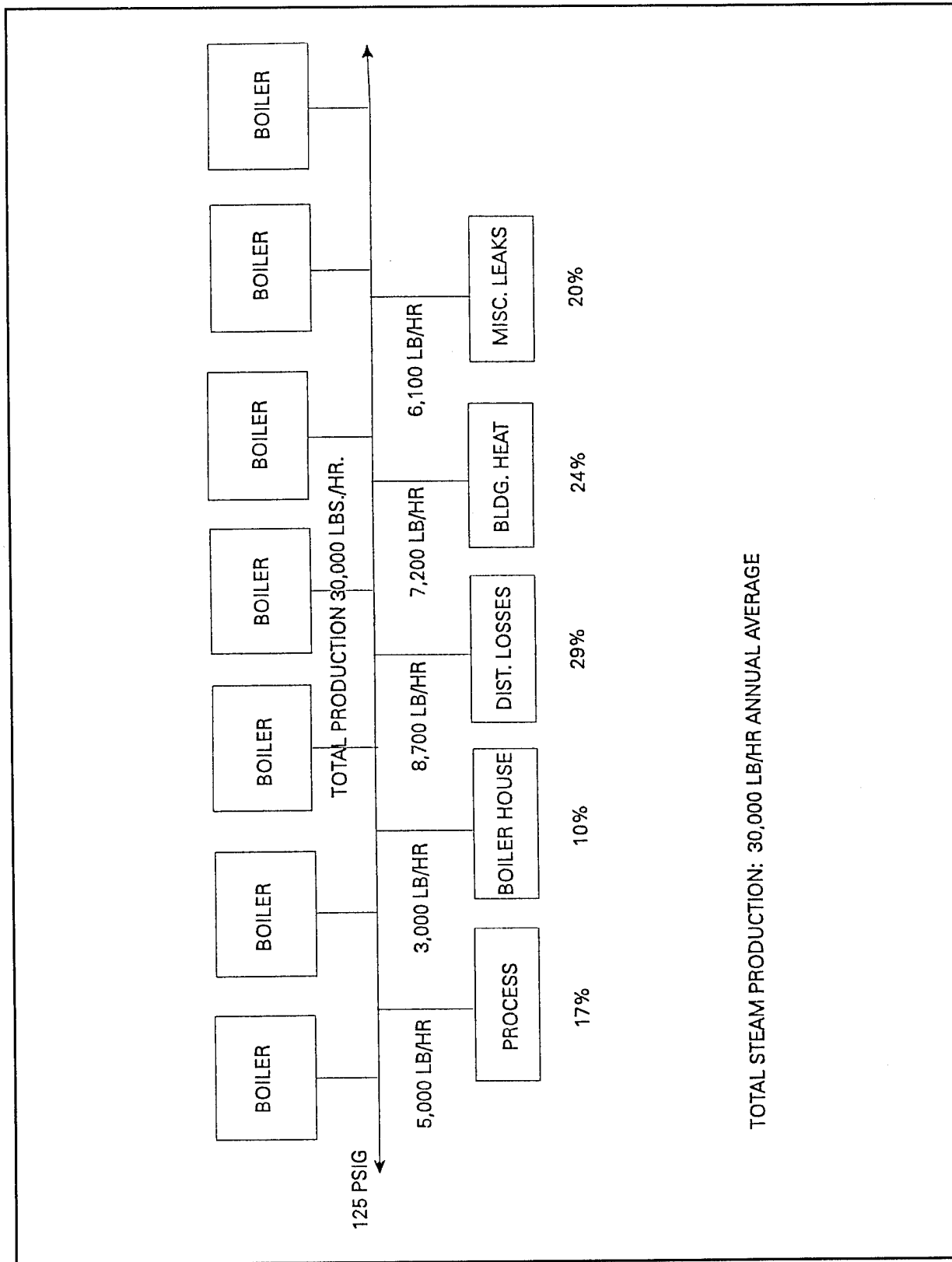

Figure 4. Steam one-line areas 1, 2, 3, and 4.

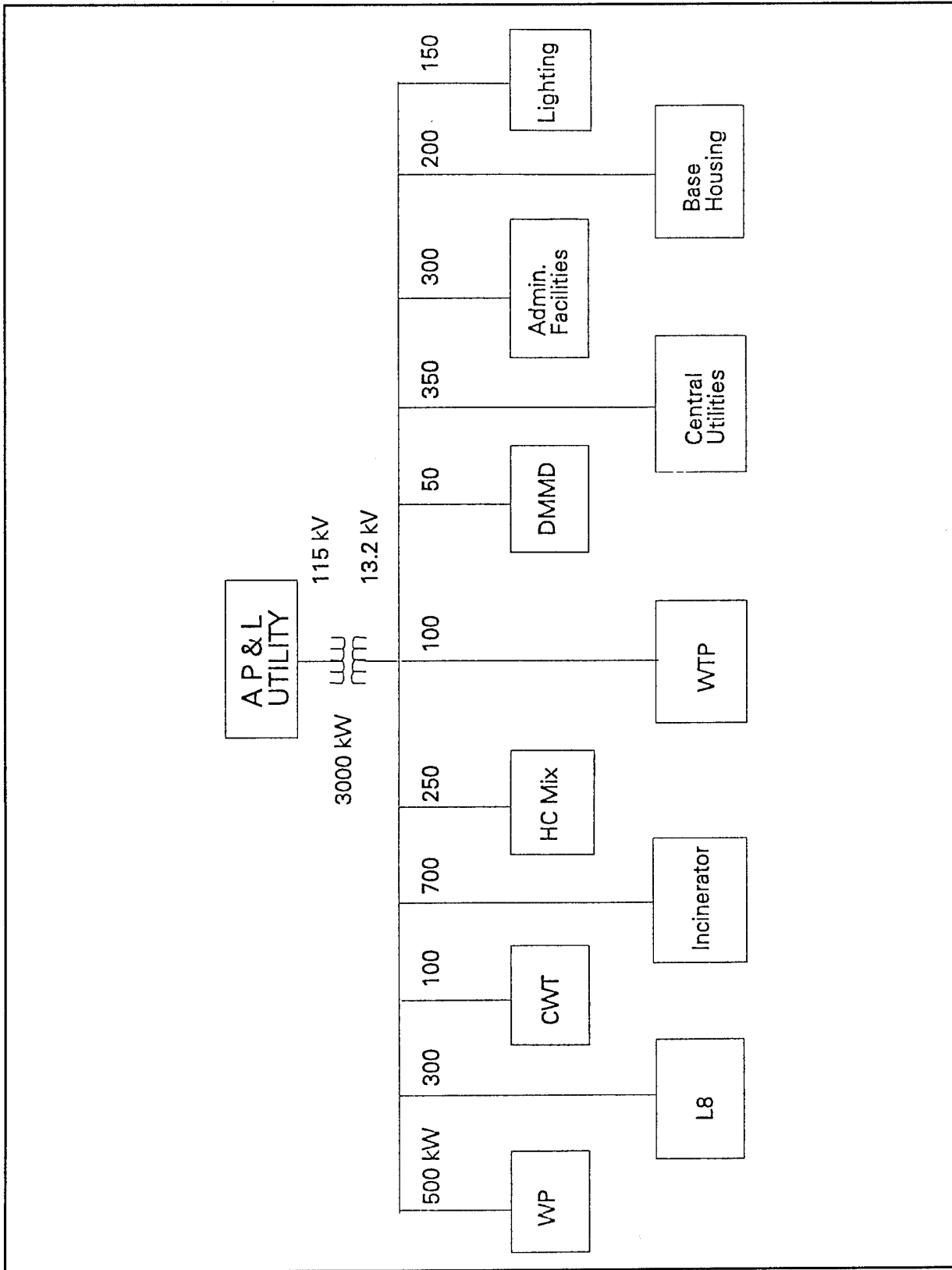

Figure 5. One-line electrical balance, PBA.

The second step is a technical analysis of the existing targeted process to determine how and where process energy is used (Figures 4 and 5). A Weakness Analysis is then used to identify areas for improvement in the existing process.

The third step uses specific brainstorming techniques to create a new process by process modification/change. The existing process is challenged and new technologies are considered. Preliminary results and ideas were presented to PBA management at the close of the review to elicit feedback and interest in pursuing Process Improvement at a Level II effort.

Review Objectives, Goals, and Review Team

The objective of the Process Review is to optimize manufacturing cost at lower levels with improved quality, raw material use, and environmental and energy performance by modifying the process operations or technology. Typical goals in these areas for commercial facilities in the private sector are a 10 to 20 percent reduction in manufacturing cost, a 5 to 10 percent increase in selling price, a 10 to 20 percent increase in capacity use, and avoiding planned future capital investments.

The overall objective was "to improve environmental, energy and other critical readiness issues at PBA by optimum use of funds." This objective is represented in Figure 6 as a "How-Why Diagram" that relates options to achieve the objective (the ultimate "Why" at the far right) to the "How's" proceeding logically in series and parallel paths to the left. Other critical readiness issues included safety, quality, reliability, productivity, maintainability, and capacity. A major goal of this pilot effort is to establish a computer-based screening model that will apply to many military facilities. The PEPR Workshop and PBA's Process Review were part of a USACERL initiative to reduce the cost and consumption of purchased energy and to strengthen PBA's environmental program. The program is unique in its heavy focus on how and why energy is used in the manufacturing operation, and in the methodology that improves energy and environmental performance through process modifications.

The Process Review uses a trained Process Review Team that follows a systematic approach and applies proven techniques of process analysis and innovation. The Review Team is largely comprised of a balance of technical, operational, and maintenance personnel from the facility. Outside consulting support provides overall guidance.

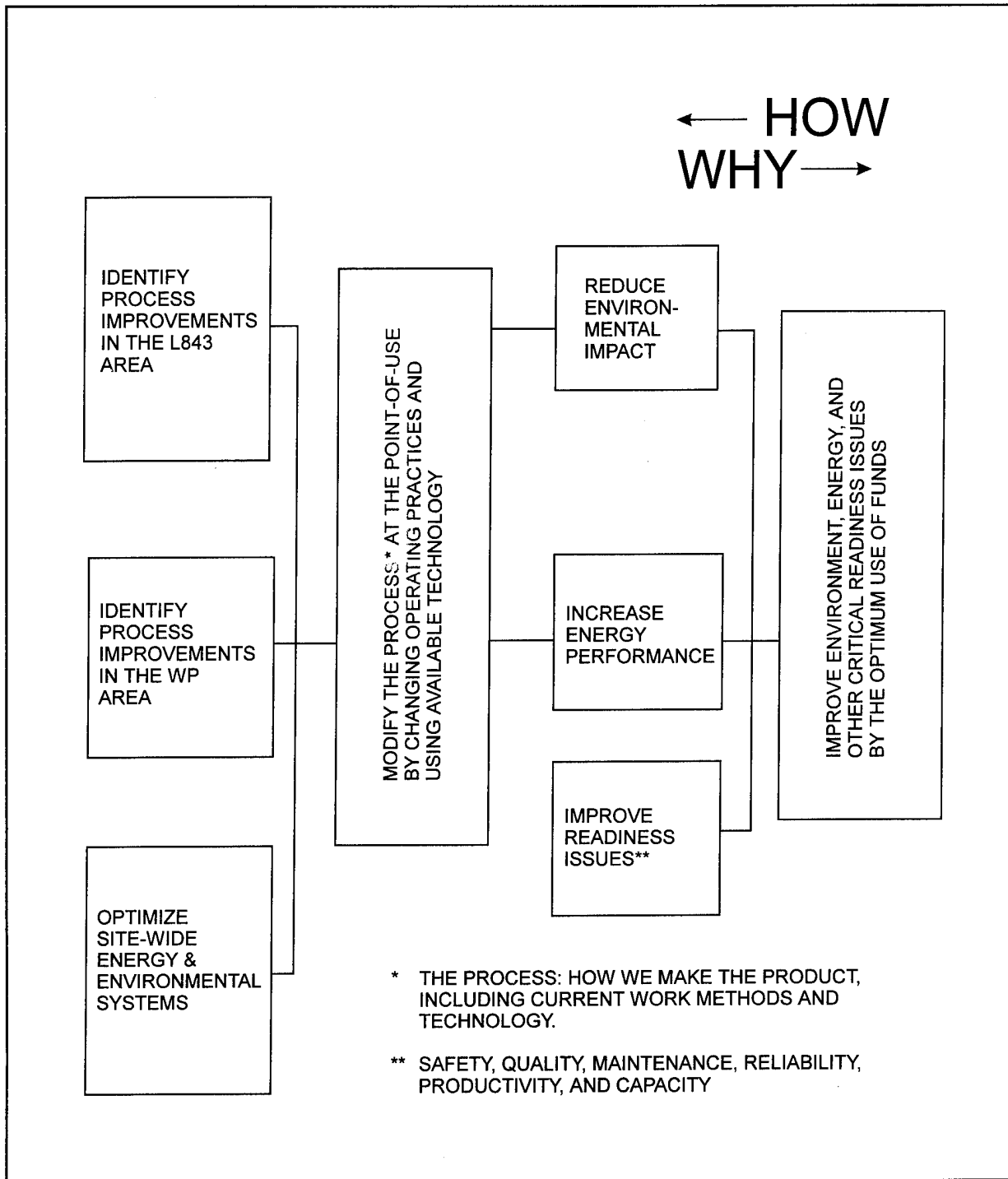

Figure 6. Primary how-why diagram for process improvements at Pine Bluff Arsenal.

Facility Cost Structure Establishing Value

The facility cost structure at PBA is unique due to PBA's manufacturing operations and the necessity of military readiness. The annual operating budget approaches \$100 million, approximately half of which is expended on operations and maintenance labor.

One of the initial tasks in the PEPR is to establish the total economic impact from potential process improvements at the site. This task is somewhat complicated at the PBA as there are currently low production levels in most manufacturing areas due to very limited current "buys" and unknown future "buys." Total energy consumption for the facility was determined from electricity and gas billing data for the past year (Tables 4 and 5).

During the 12-month period from May 1993 to April 1994, the PBA spent \$1,511,656 on electricity and \$1,682,525.87 on natural gas, for a total of \$3,194,181.87 (approximately 3 percent of operating budget). The most significant cost item is operating and maintenance labor (\$50 to \$55 million per year). The potential to reduce energy and environmental emissions through process improvement is believed significant. However, a far greater cost reduction potential is possible from corresponding increases in labor use and productivity through process improvements.

Process improvements in the manufacturing operations can also significantly reduce future capital investments in energy and environmental infrastructure, and free up capital for other production purposes. The section **Estimating Dollar Benefits Based on a Level I Analysis** (below) compares a 10-year scenario with and without Process Energy and Pollution Reduction.

Analyzing the Existing Process and Energy Infrastructure

Site Description

Pine Bluff Arsenal facility was constructed in 1942 on 15,545 acres of timberland, of which 4867 acres have been developed into the operating facility. PBA's specific mission within the Army AMCCOM is to:

1. Produce conventional smoke, riot control, incendiary and pyrotechnic mixes and munitions
2. Provide depot operations for conventional chemical munitions, lethal chemical munitions and materials

3. Destroy (demilitarize) chemical munitions
4. Repair and maintain chemical defensive equipment.

The overall facility is divided into three general areas: (1) ammunition production (South), (2) Administrative (Central), and (3) Depot and Binary (North). All audit activities were focused on the ammunition production area.

During World War II, PBA had as many as 50 operating production areas and a total of 25,000 personnel. Large centralized steam and compressed air production and distribution systems were developed to support the facility. At the time of this review, five production areas were operating that would be available as the focus area for the review. The WP Fill area was not operating, but was considered for evaluation because of its significant energy consumption during production and because of the area's requirements for pollution control.

Three specific areas were defined for process energy reduction activities: (1) White Phosphorus—WP Fill/Assembly, (2) L8A3 Mix, Fill, and Assembly, and (3) Central Steam and Compressed Air Systems. Figures 7, 8, and 9 show process schematics. A brief review of the central incinerator was conducted with the focus on environmental issues (Tables 6, 7, and 8). The general PEPR methodology was applied to each area, including weakness/problem identification (Tables 9 and 10), brainstorming (Tables 11 and 12), and developing the how-why diagram (Figures 10 to 18).

Steam Generation and Distribution System

Boilers in the production area that supply steam to the central distribution system are located in buildings 32-060, 33-060, and 34-140. The boilers in buildings 32-060 and 33-060 are identical and feed into a common header serving the buildings in the manufacturing area. These boilers are watertube, type "H" sterling boilers manufactured by Babcock and Wilcox. Combustion air is supplied by a forced-draft fan and is controlled by a jack-shaft damper arrangement. Boilers located in building 34-140 also feed the common header serving the manufacturing area. The three identical boilers were manufactured by Babcocks and Wilcox, watertube boilers model HSB-13168. The boilers are controlled to supply steam at 140 psig (pounds per square in gauge). Table 13 summarizes the capacities of these boilers. Figure 4 shows a One-Line Steam Balance for the site, with estimates of steam loads to functional users. Significantly, for all steam produced, only 17 percent is used in manufacturing, 24 percent in building heating (Figure 19), and the remaining 59 percent is accounted for by system losses. The analysis outlined in Figure 20 suggests decentralizing as a solution.

ITEMS SUPPORTED

LINE 1

- 105MM, MICEE1
- 4.2", M326
- 2.75", M156
- CANISTER, MK14
- 105MM, M416
- 80MM, M302
- 80MM, M722

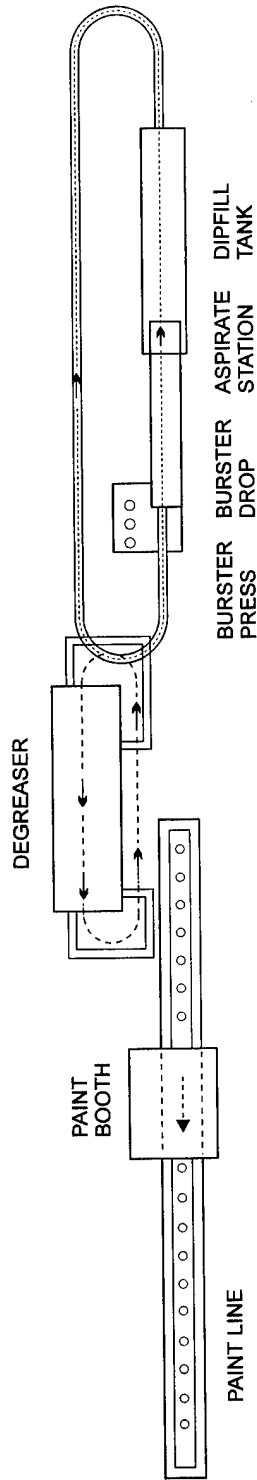
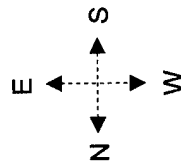

Figure 7. Line No. 1 dipfill.

ITEMS SUPPORTED

LINE 2

2.75", M259
155MM, M825

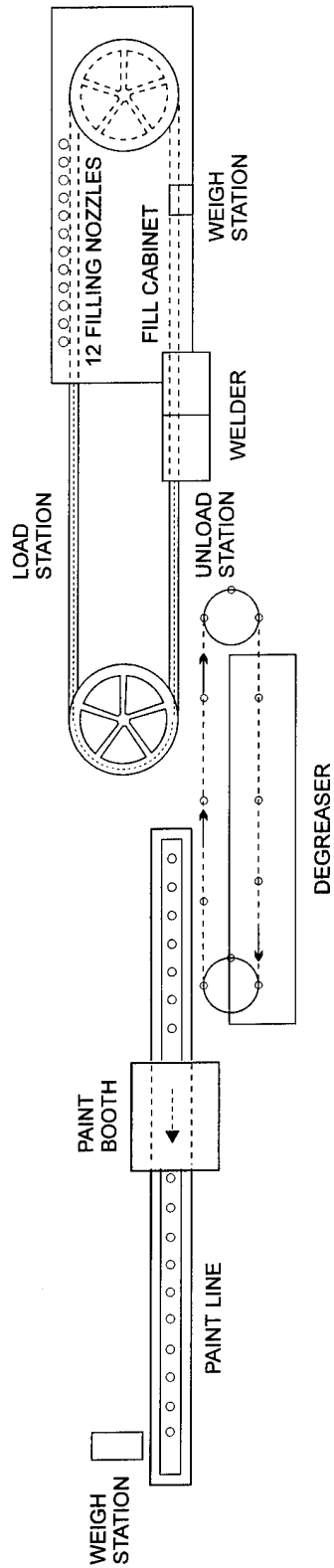
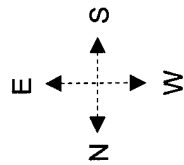

Figure 8. Line No. 2 dryfill.

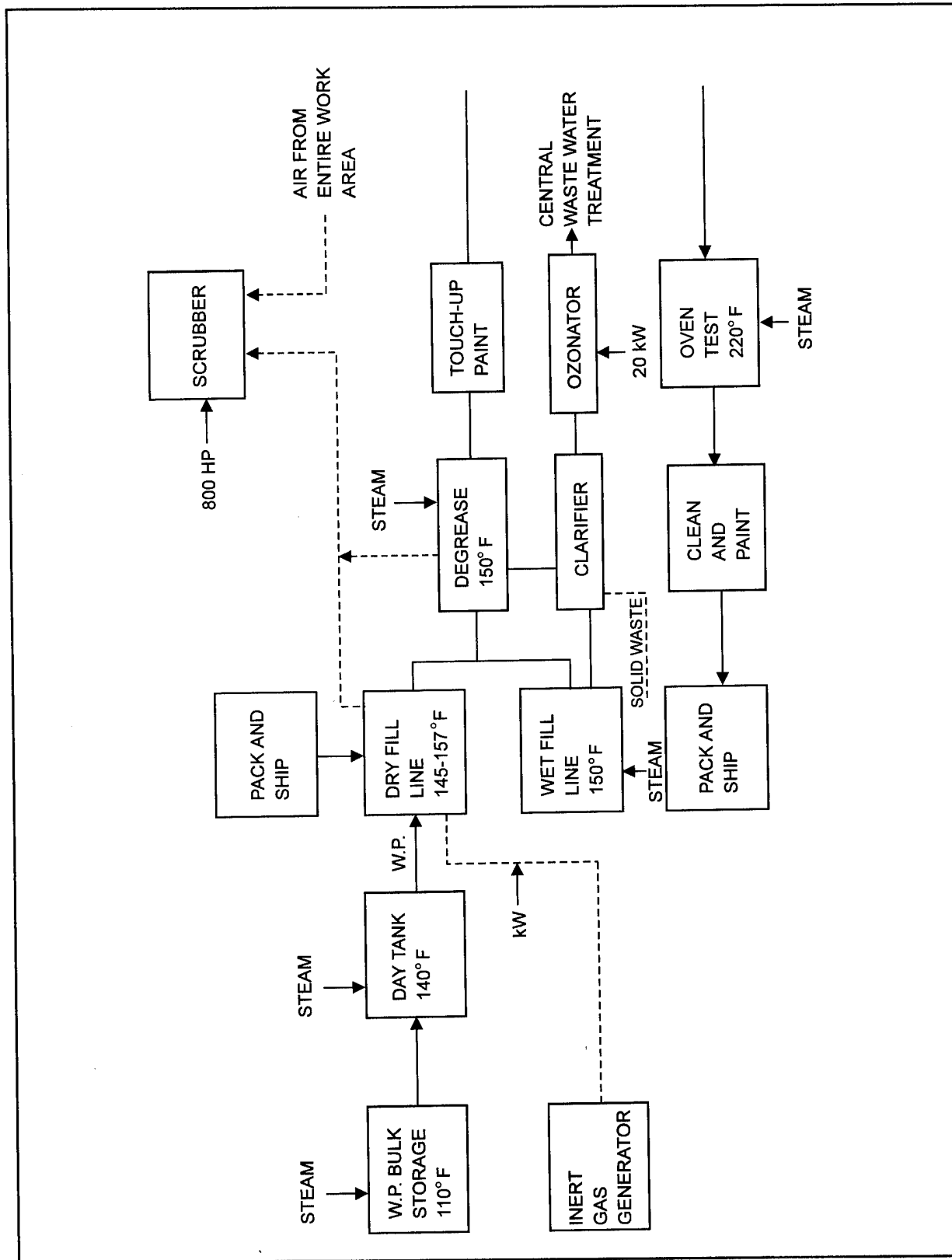

Figure 9. WP fill block process flow diagram.

Table 6. Improvements to optimize the central steam system and improve the effectiveness of energy utilization at the point-of-use.

1.	Improve steam production and distribution systems
2.	Increase boiler efficiency
3.	Lower steam pressure
4.	Install oxygen trim system
5.	Tune-up boilers using portable oxygen analyzer
6.	Implement currently valid recommendations from previous studies
7.	Reduce distribution steam losses
8.	Decommission idle steam segments
9.	Install or fully utilize condensate return system
10.	Repair leaks, traps and insulation (establish Leak Buster Team)
11.	Reduce building heat requirements
12.	Install or up-grade controls
13.	Consider alternate sources to the central steam system to supply heat
14.	Use solar hot water to heat buildings at night
15.	Use electric heat pumps for remote buildings

Table 7. Improvements to optimize the central electrical system and improve the effectiveness of energy utilization at the point-of-use.

1.	Improve the electrical distribution system
2.	Install energy management control system to control peak demand
3.	Improve utilization of compressed air
4.	Increase compressor efficiency
5.	Reduce pressure at central compressor to meet only largest legitimate need of end-use
6.	Evaluate opportunities to reduce pressure requirement of user setting pressure requirement
7.	Control air compressors to run only when needed
8.	Use less compressed air
9.	De-centralize compressed air supply
10.	Decommission idle compressed air lines
11.	Establish Leak Buster Team to Repair leaks
12.	Investigate use of desiccant AC

Table 8. Improvements to optimize the central industrial waste water treatment system, sanitary waste water treatment, central water treatment, and incineration facilities

1.	Control blow-down from incinerator and process scrubbers
2.	Evaluate mechanical vapor recompression to concentrate waste water treatment streams and liquid steams going to the incinerator
3.	Recover heat from the fluidized bed incinerator
4.	Use reed bed holding pond at sanitary water treatment facility
5.	Install ozonator for waste water treatment
6.	Recycle water to reduce hydraulic load to industrial and sanitary waste water treatment plants
7.	Investigate water treatment plant motor efficiencies, load matching, and load control

Table 9. Weakness analysis for white phosphorous production line.

Energy	Labor & Capacity	Environmental	Quality	Maint./Reliability	Safety
Steam Leaks	High Downtime at Dryfill Lines	WP Leaks	Touch-up Painting	Power Failures	Heat in Work Place
Degrease at 150°F		VOCs Off Paint Step(s)	Surface Oxidation of Shells	Dryfill Nozzles	WP Leaks
800 kW Exhaust to Scrubber		Waste Water			
Oven Heat		Clean Up System			

Table 10. Weakness analysis for red phosphorous I8a3 production line.

Energy	Labor & Capacity	Environmental	Quality	Maintenance / Reliability	Safety
Cannot Modulate Fan Power	Clips	Noisy Fan	00% Rejects on Top Contact	Pellet Presses	Black Powder Storage
Air Cond. Effectiveness	Air Permit (Batch Limit)	Excessive Solid Waste	typical Rejects: 1-5%	Flow Meters on MCL	Breathing Apparatus Recovery
Cubicle Environment		MCL Losses			
		RP Droppings			
		Waste Water			
		Clean-Up System			

Table 11. Process improvements to reduce emissions and energy consumption at the point-of-use.

No.	Improvement
1.	Convert inert gas generator to alternative technology
2.	Evaluate molecular sieve or Pressure Swing Adsorber technology for inert gas
3.	Solve power reliability problem
4.	Install engine generator set
5.	Add ozone before the clarifier to reduce hazardous waste
6.	Skip second paint step
7.	Reduce steam pressure to entire WP area
8.	Lower steam temperature requirements to test oven
9.	Use alternative technology to preheat shells
10.	Use IR heater
11.	Solve high maintenance problem with fill nozzles
12.	Redesign fill nozzles
13.	Reduce bulk heating of long-term storage
14.	Use suction heater for at WP storage outlet
15.	Replace solvent based paint requirements in Mil-Spec
16.	Use Jeri and USACERL to accomplish above
17.	Evaluate cogeneration for reliable power, hot water/steam, and inert gas production (3rd party financing)
18.	Replace scrubber with alternative technology
19.	Modify use and control of 800 HP fan on scrubber
20.	Eliminate need for scrubber
21.	Improve efficiency of hood designs
22.	Provide indoor air monitoring to minimize exhaust system to scrubber
23.	Replace steam heat to solar with storage
24.	Control temperature of containers leaving wet fill
25.	Eliminate wet fill lines
26.	Minimize inert gas needs
27.	Eliminate test oven step
28.	Fix leak problems
29.	Find an alternative to oven test step
30.	Eliminate use of steam
31.	Improve degreasing step with less soap
32.	Use hot water for steam or staged heating

No.	Improvement
33.	Use a different metal for shell casing
34.	Replace metal casing with engineering plastics
35.	Use anodized Aluminum casing
36.	Improve worker comfort with cooling jackets
37.	Fix uninsulated steam lines
38.	Fill casing with nitrogen before wet fill to reduce sludge production
39.	Institute Total Productive (Preventive) Maintenance
40.	Use waste heat from test ovens
41.	Use carbon filters on VOC emissions
42.	Route paint booth VOC to scrubber
43.	Make oxygen and use nitrogen by-product for inert gas
44.	Fix all leaks (steam, phosphorous, and air)
45.	Provide engineering solutions to leaks.

Table 12. Process improvements to reduce emissions and energy consumption at the point-of-use.

No.	Improvement
1.	Change contractor for clips (Q,L,C)
2.	Change/redesign clips (Q,L,C)
3.	Put plastic protector over clip in transit (Q,L,C)
4.	Recirculate HVAC air (E)
5.	Modulate fan speed based on need of individual cubicles (E,EV)
6.	Improve cubicle thermal envelope (E)
7.	Handle MCI in hoods, etc. to eliminate breathers (S)
8.	Use catalytic polymer to eliminate MCI (S)
9.	Use alternate ways to clean up; minimize wash down (EV)
10.	Automate worker tasks (all)
11.	Add variable speed drive with smart control to MCI recovery fan (E)
12.	Add sensors for HVAC, humidity, and temp control in the individual cubicles (E)
13.	Provide HVAC control System (E)
14.	Use water from MCI recovery process for wash down
15.	Reduce RP droppings by redesigning oven racks
16.	Change pellet press control to PLC (M)
17.	Use vacuum system to collect loose mix (EV)

No.	Improvement
18.	Use steam pressure needed to allow lower central pressure boiler operation (E)
19.	Granulate and coat at the same time (EV)
20.	Do process control, not quality control (Q)
21.	Look at off-peak storage for HVAC (Cost)
22.	Replace noisy fan with high efficiency, quiet one (E, EV)
23.	Evaluate loads on breathing air and process air requirements (E, EV, S)
24.	Assess conditions in drying ovens (E)
25.	Eliminate drying ovens (E)
26.	Install an ozonator (EV)
27.	Mechanize continuity test (Q)
28.	Ozonate liquid before putting into solid waste (Ev)
29.	Heat recovery from cool down of ovens (E)
30.	Change grenade/shell material (E, Ev, L/C)
31.	Pull vacuum on RP to eliminate oven step (E, Ev)
32.	Heat rubber (do not dissolve) to eliminate MCI (E, Ev)
33.	Use injection molding instead of pellet press (M,Q)
34.	Substitute epoxy rubber instead of butyl rubber (Ev)
35.	Fix leaks (E, Ev)
36.	Use higher volume press (L/C)
37.	Improve overall recovery efficiency of MCI (now 80%) (E, Ev)
	(a) Increase residence time in carbon bed
	(b) Reduce flow to carbon bed
	(c) improve MCI capture system
	(d) Optimize regeneration time
	(e) Evaluate 2 absorber in series vs. 2 in parallel
38.	Put oven step in cubicle to minimize handling production (Ev, L/C)
39.	Use steam cleaning instead of water wash (Ev)
40.	Simultaneously operate both sides -- control them separately (E, L/C)
* Identifies weakness/problem are being addressed	

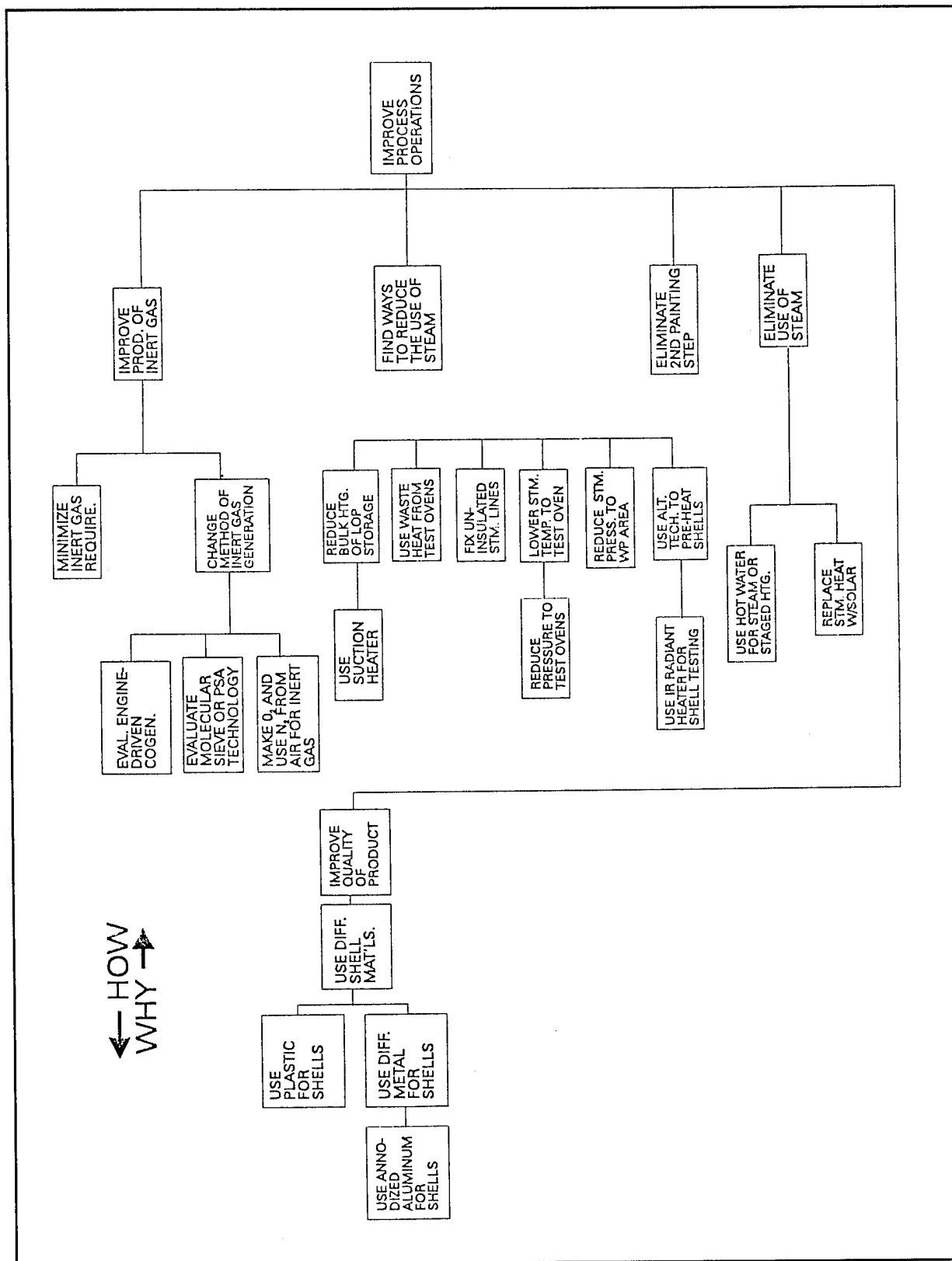

Figure 10. WP fill how-why diagram; improve process operations.

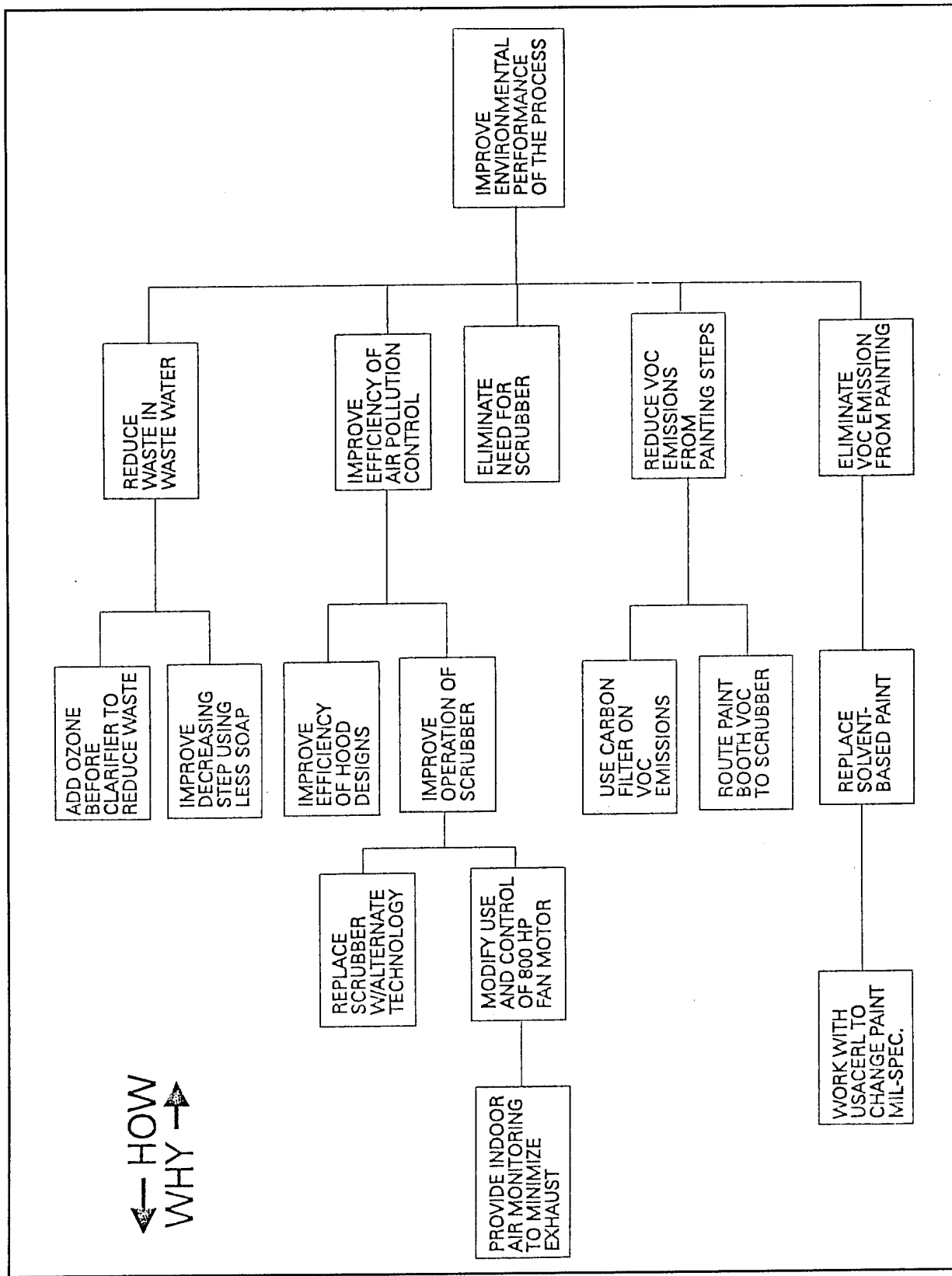

Figure 11. WP fill how-why diagram; improve environmental performance of the process.

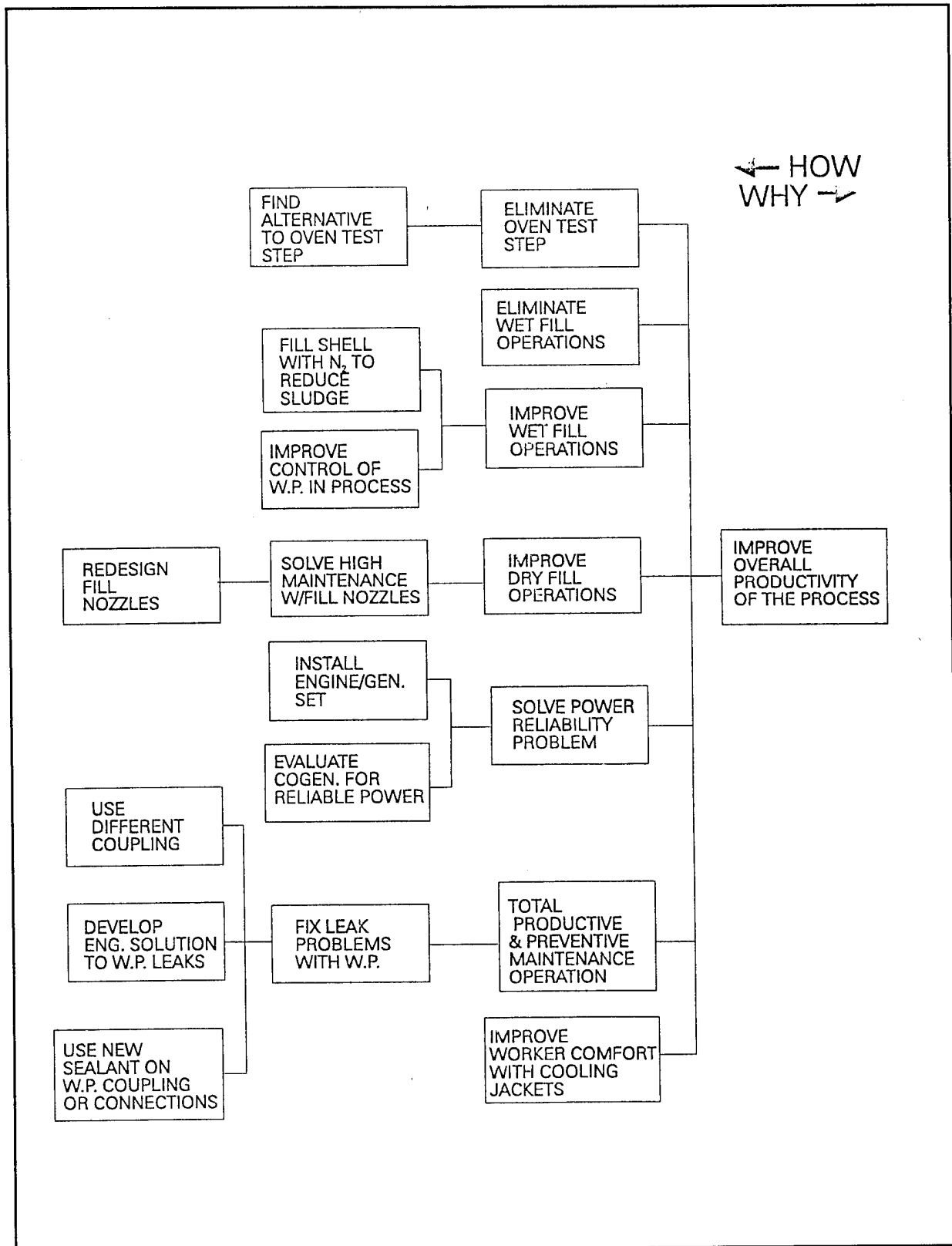

Figure 12. WP fill how-why diagram; improve overall productivity of process.

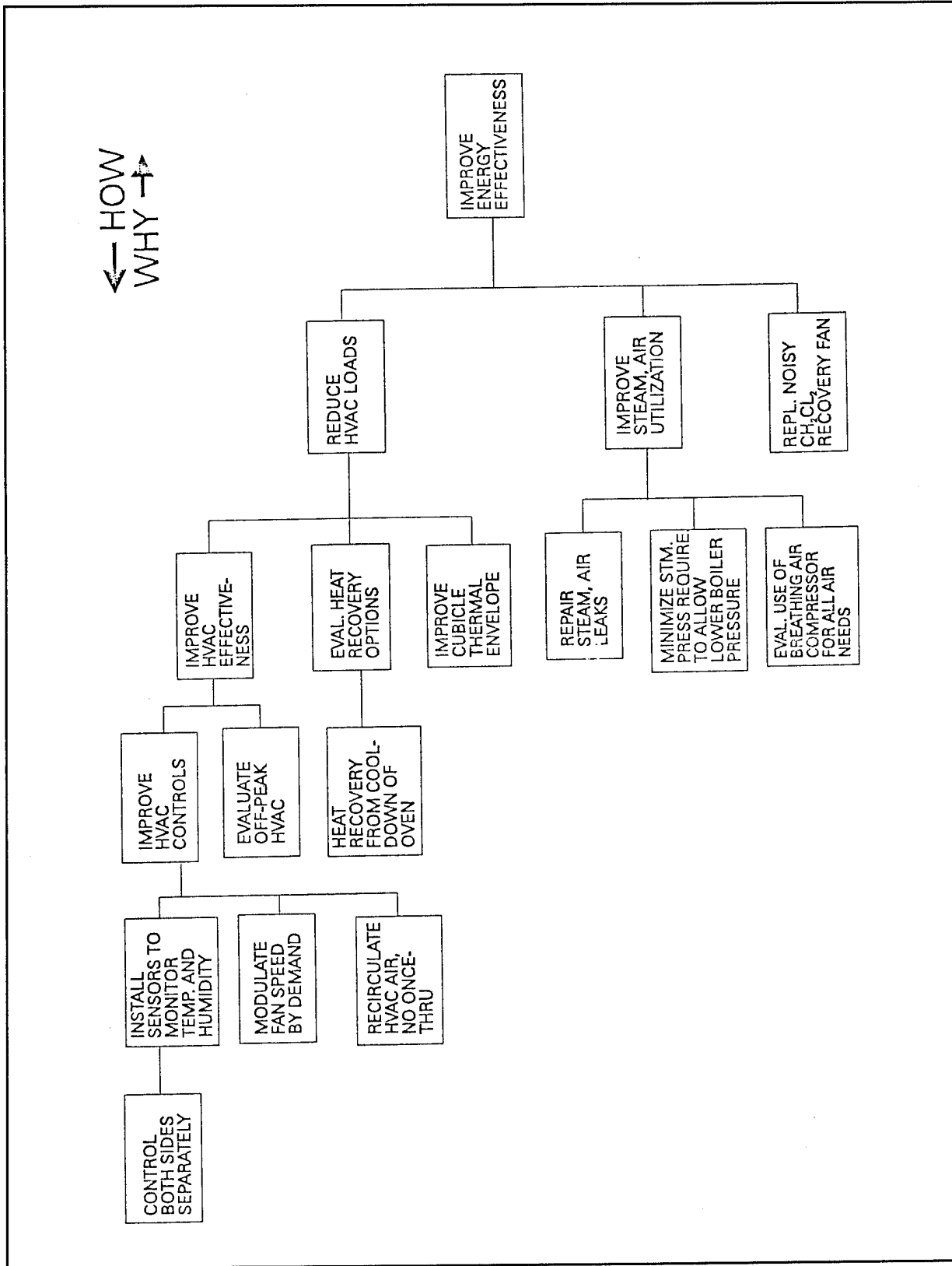

Figure 13. Improve performance of L8A3 production how-why diagram; improve energy effectiveness.

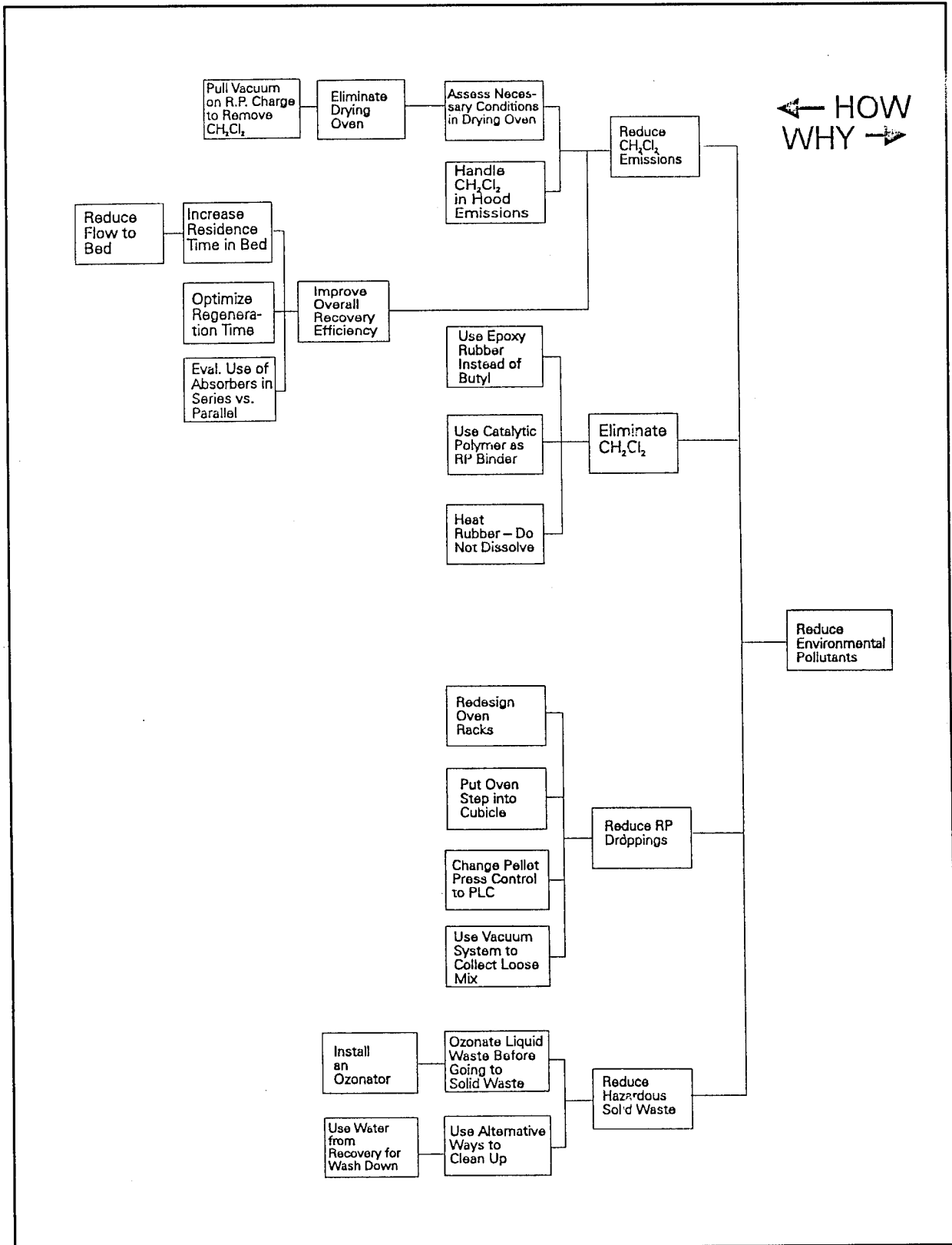

Figure 14. Improve performance of L8A3 production area how-why diagram; reduce environmental pollutants.

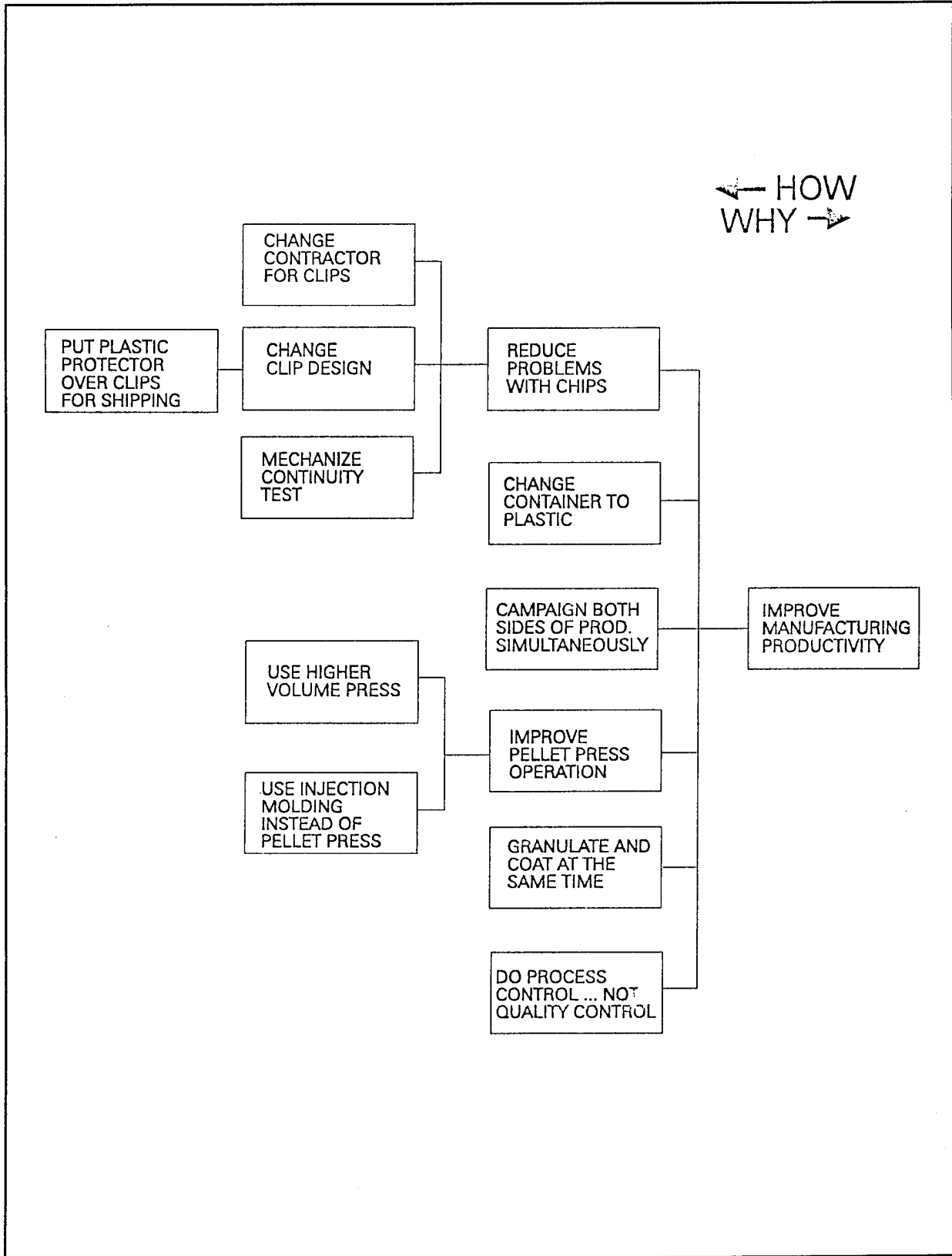

Figure 15. Improve performance of L8A3 production area how-why diagram; improve manufacturing productivity.

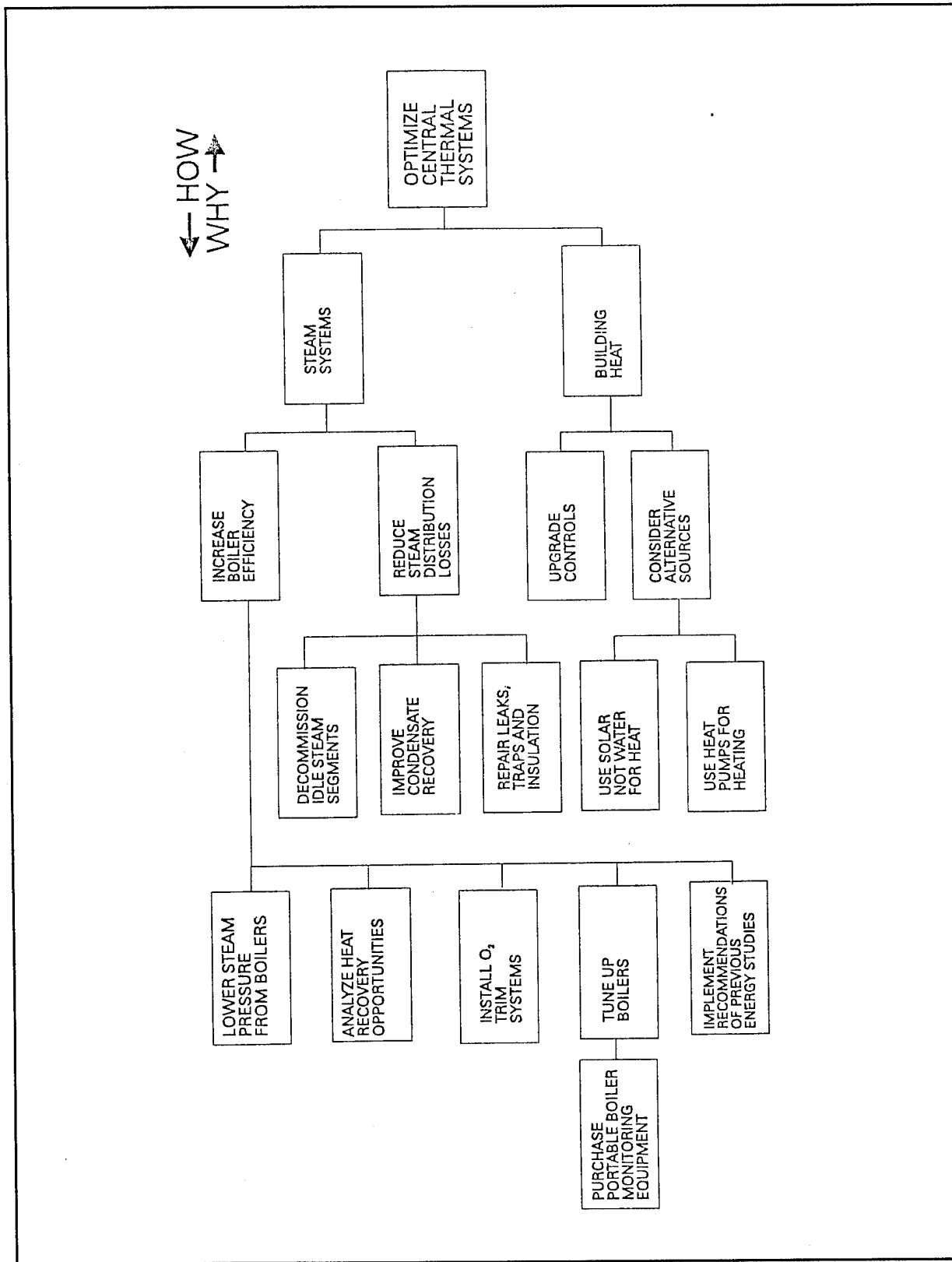

Figure 16. Improve performance of site-wide central systems how-why diagram No. 1; central thermal system.

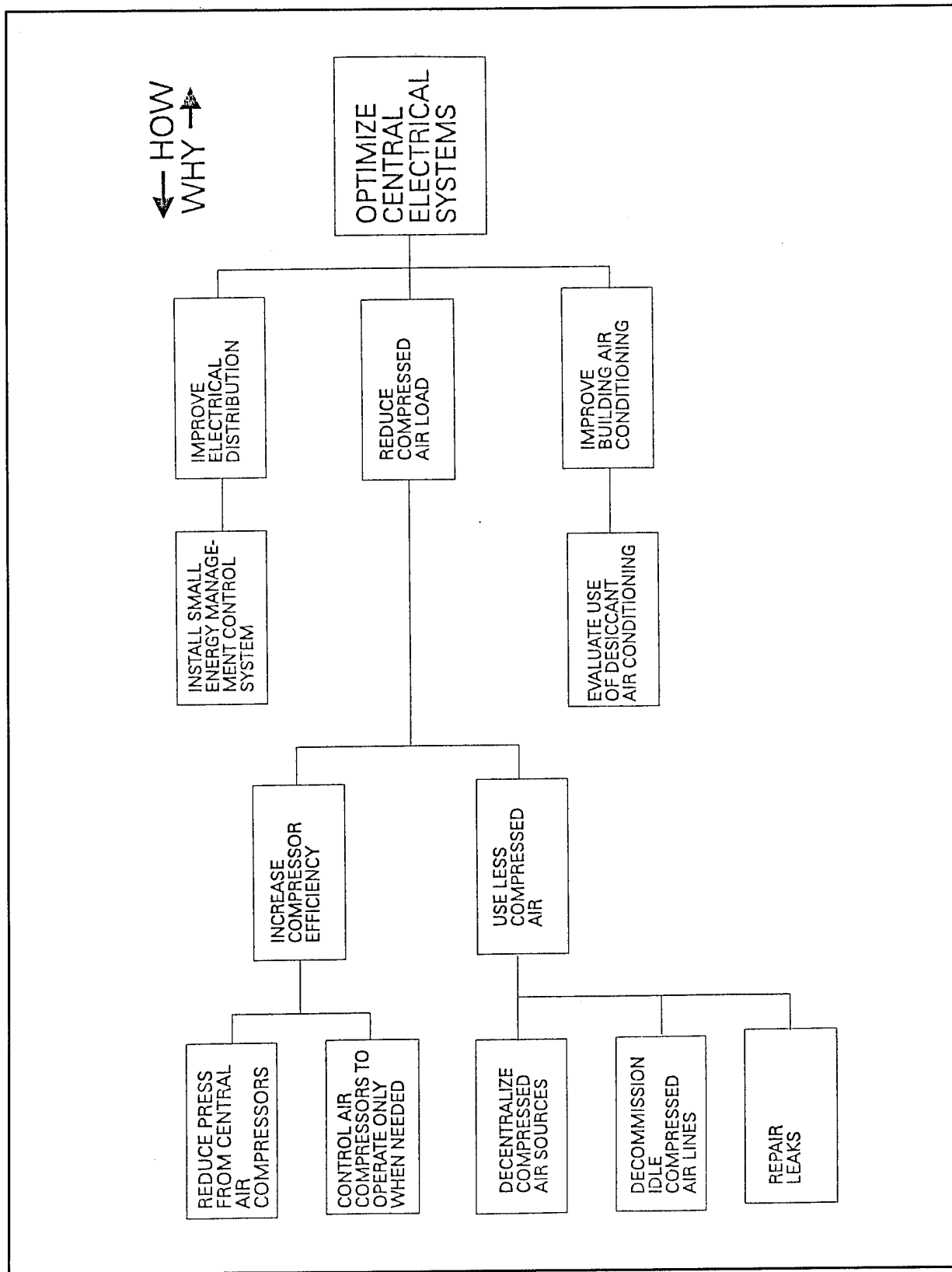

Figure 17. Improve performance of site-wide central systems how-why diagram No. 2; central electrical system.

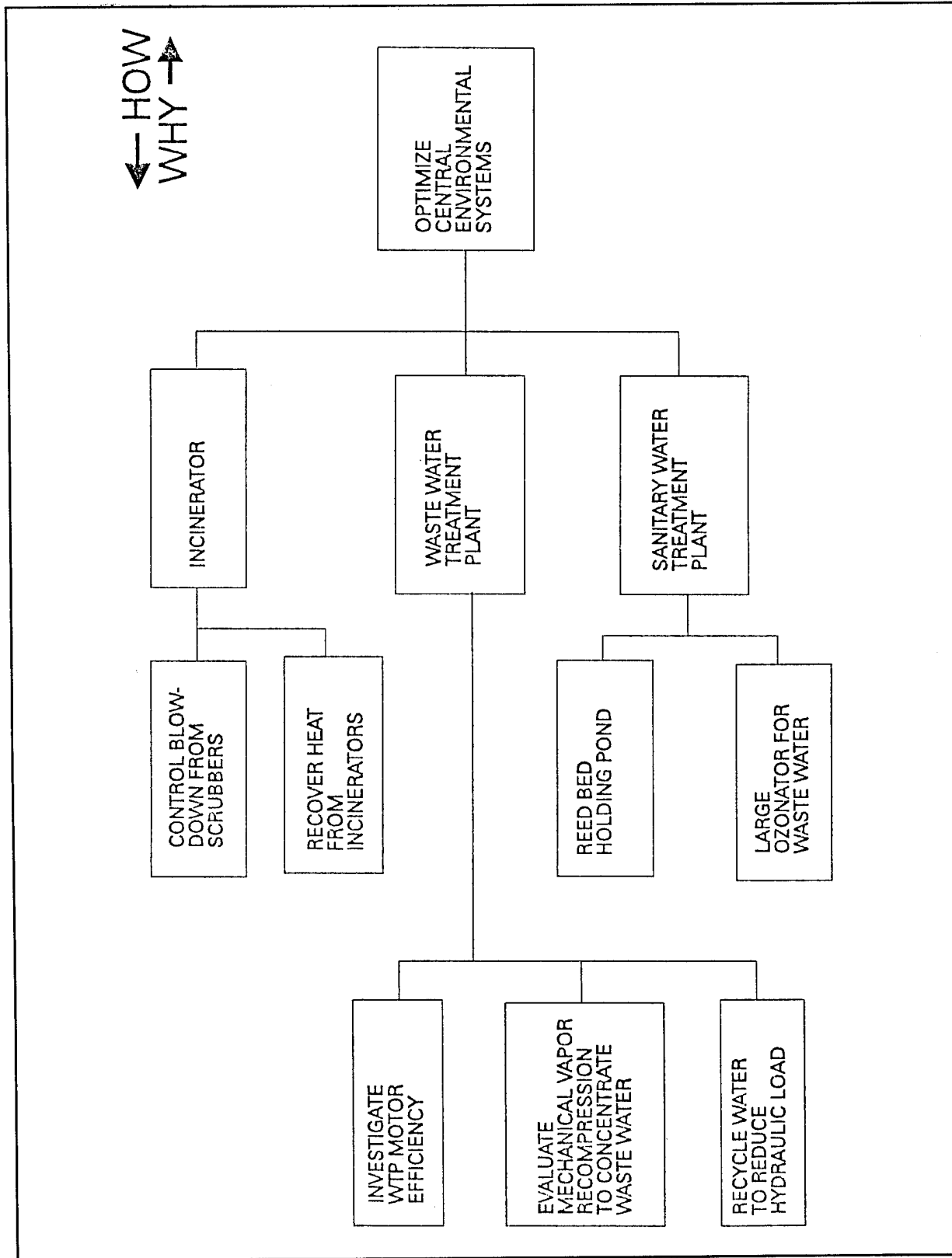

Figure 18. Improve performance of site-wide central systems how-why diagram No. 3; central environmental systems.

Table 13. Central heating plant boilers for production area.

Boilers Located in Building Number	Nominal Boiler Capacity	
	(BTU per Hour)	Number of Boilers
32-060	10,400,000	2
33-060	10,400,000	2
33-140	8,340,000	3

The steam distribution system and condensate return system serving the production area have approximately 68,000 linear feet of piping that supplies steam to the buildings and returns condensate. Of this, 34,000 ft is steam piping and 34,000 ft is

condensate return. All piping is above ground and the steam piping is mostly covered with 1 to 2 in. of insulation. Condensate is collected in pits and, if the system worked as designed, would be returned to the boilers by steam pressure. However, it is estimated that only 20 percent of the condensate is currently being returned to the boilers.

Electrical System and Compressed Air

Figure 5 shows a One-Line Electrical Balance, which accounts for an annual average load of 3000 kW (26 million kWh per year over 8760 hours).

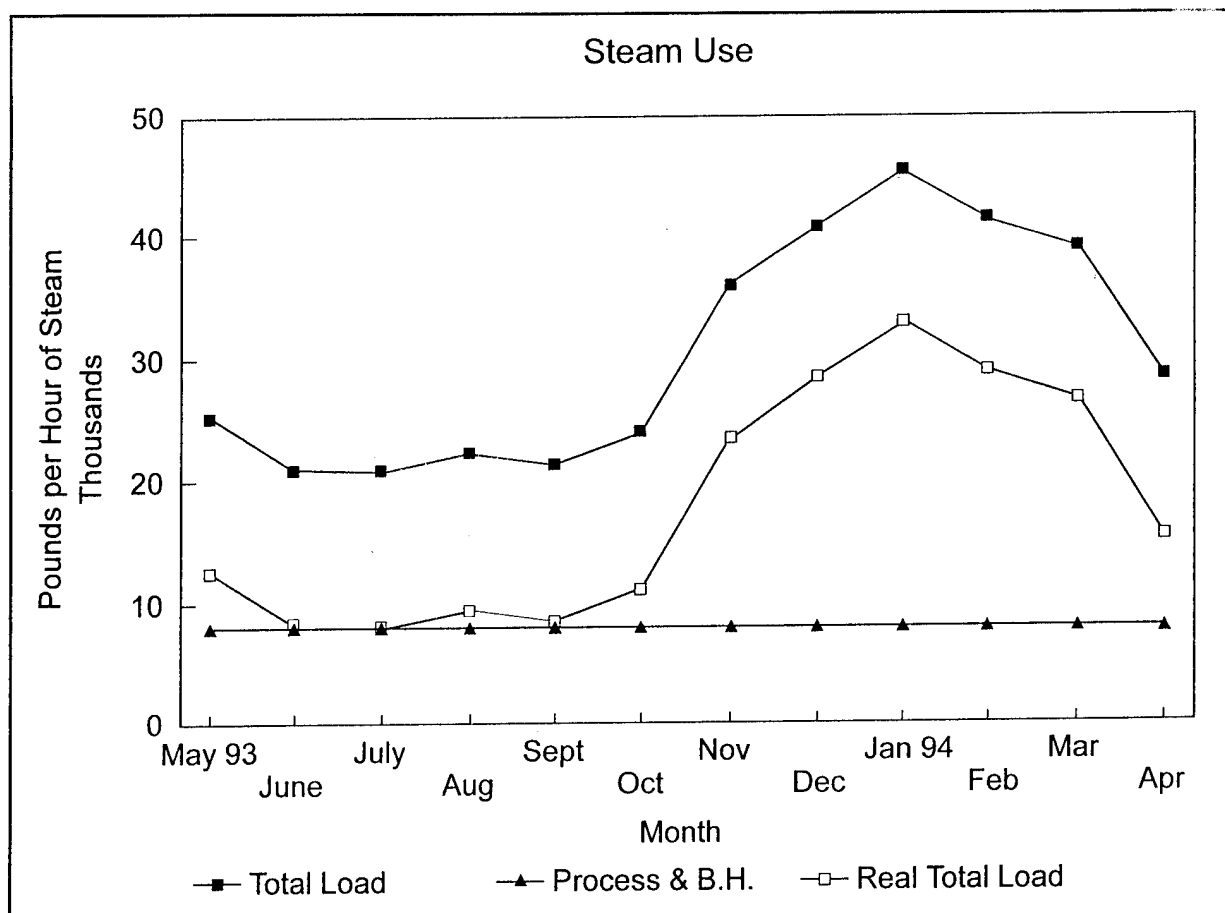

Figure 19. Steam use for boilers 32, 33, and 34.

Problem

Central energy supply and distribution systems are designed for full production capacity.

Solution

Downsize and/or decentralize to match legitimate process need.

- Decommission-idle piping segments
 - Compressed air
 - Steam
 - Condensate
- Portable decentralized compressed air units.
- Cluster production facilities when possible.
- Optimize use of smaller boilers to meet process needs.

Analysis of steam cost due to high percentage distribution losses:

Cost of Steam: Fuel (N.G.) \$3.33/10⁶ Btu

Boiler Efficiency: 75%

Heat-in-steam: 1100 Btu/lb steam

Assume Fixed cost equal to variable

From one-line steam balance (Figure 2A): Only 41% is currently used by process (17%) and building heat (24%).

Therefore, the true unit cost for steam actually consumed by the user is:

1. Variable (fuel only) exported from boilers

$$\frac{\$3,33.195 \text{ Btu} \times 1100 \text{ Btu/lb}}{0.75} = \$4.88/\text{K LB}$$

2. Cost per unit consumed by process and building heat

$$\frac{4.88}{0.41} + \frac{4.88}{\text{(Fixed)}} = 11.90 + 4.88 = \$16.78/\text{K lb}$$

Figure 20. Weakness analysis of central utility systems.

Compressed air is used throughout the production area in various manufacturing processes. The compressors are located in the central plant boiler houses. Six 173-horsepower (HP) XLE Ingersoll-Rand and two 75 HP Worthington two-stage reciprocating compressors provide air at 100 psig to a common header from which air is distributed to the loads.

Creating the New Process

Process Innovation both questions and challenges the existing process operating conditions, procedures, and practices, and considers where new technologies can be used. The result is a new process with significant improvement in performance. At the PBA, this Level I PEPR focused on energy and environmental issues that affected the production area. The Process Review Team used several brainstorming techniques to develop Process Improvement Ideas. Brainstorming techniques include "Silent Idea Generation" (S.I.G.) and development of How-Why diagrams. Figure 6 shows a sample How-Why Diagram. The primary "Why" at the far right on Figure 4 for this PEPR was to "Improve Environmental, Energy and other Critical Readiness Issues by the Optimum Use of Funds." The How's by which the Why is achieved are positioned to the left, such as "Increase Energy Performance." Three operations were examined:

1. Process improvements in the L8A3 area
2. Process improvements in the WP Fill area
3. Optimization of site-wide energy and environmental systems.

The operations identified were first reviewed to define areas of weakness or problems. Based on these problems, the areas were brainstormed using the S.I.G. technique during a concentrated 10 to 15 minute period. All individual ideas were listed on a flip chart, discussed for clarification, and condensed into How-Why diagrams.

WP Fill Area

Figure 7 shows a schematic presentation of the WP Fill Dip Fill (Wet) process; Figure 6 shows the Dry Fill Process. Figure 9 shows the overall Process Block Flow Diagram developed for this area. Table 9 lists the weak points identified in the Weakness Analysis of the WP Fill Area. Brainstorming this Weakness Analysis identified 45 ideas (Table 11). These ideas were then structured into three How-Why diagrams that addressed ideas to "Improve Process Operations" (Figure 10), "Improve Environmental Performance of the Process" (Figure 11), and "Improve Productivity of the Process" (Figure 12).

L8A3 Area

Table 10 lists the wear points identified in the Weakness Analysis of the L8A3 Area. Brainstorming this Weakness Analysis identified 40 ideas (Table 12). These ideas were then structured into three How-Why diagrams that addressed "Ideas to Improve Energy Effectiveness" (Figure 13), "Reduce Environmental Pollutants of the Process" (Figure 14), and "Improve Manufacturing Productivity of the Process" (Figure 15).

Site-Wide Centralized Energy Systems

A Weakness Analysis of the central utility systems concluded that the major problem with the systems was the existing oversize for required current loads (Figure 20). Figure 4 shows a diagram of the central steam system. Brainstorming the site-wide central systems identified more than 40 ideas in three areas (Tables 6, 7, and 8). These ideas were then structured into three How-Why diagrams that addressed "Ideas to Optimize Central Thermal Systems" (Figure 16), "Optimize Central Electrical Systems" (Figure 17), and "Optimize Central Environmental Systems" (Figure 18).

Site-Wide Environmental Systems

Pine Bluff Arsenal has four incinerators for disposal of waste materials. Three of the incinerators are connected to a single afterburner for final waste destruction. These units are: the car bottom, the rotary deactivator, and the chain grate. Each of these units has a maximum heat release of 3.5 million Btus per hour. The afterburner has a burner capacity of 20 million Btus per hour.

The design temperature for the afterburner is 1648 °F. The fourth incinerator is a fluidized bed. The bed is a silica base and the unit is also operated at approximately 1648 °F. Because of the high temperature of the fluidized bed, an afterburner is not required.

Both the fluidized bed and the afterburners discharge to their own quencher/scrubber systems. The quenchers reduce the flue gas temperatures to around 250 °F and the scrubbers remove particulate matter. New fiberglass scrubbers will remove 99.99 percent of the particulate entering the scrubber. The existing scrubbers have an outlet emission concentration limit of 0.08 grains per standard cubic foot (SCF). The new units will have outlet limits of 0.02 grains per SCF. The scrubbers use caustic for pH control and remove the HCl in the flue gases. The ductwork between the incinerators and the quenchers is all made of Inconel 625, an expensive alloy designed to withstand the corrosive environment created by the HCl.

The incinerators burn a variety of waste materials. The quantity and composition of the waste to be disposed of cannot be controlled. Some of the material, such as tear gas, has a very high heating value. Other wastes, such as those from wastewater treatment plants, have no heat content at all and impose a significant heat duty on the incinerator.

The incinerator systems appear to be well maintained and operated. They are highly regulated with regular unscheduled inspections from several government agencies. The cost of natural gas for the incinerators was estimated to be from \$250,000 to 500,000 for 1994. Normally, heat recovery would be considered from the high temperature waste gas streams; however, due to the highly corrosive characteristics of this waste gas, the cost of heat recovery equipment is not economically justified. The combined incineration of high-heat-content wastes with high-water-content wastes is recommended when possible. This may, in fact, increase the rate for burning the highly volatile waste material as much as possible before incineration. The purchase of new equipment for this operation may be justified. Mechanical vapor compression is one technology that should be investigated. This type of equipment might achieve a five- to tenfold reduction in the amount of water incinerated.

Estimating Dollar Benefits Based on a Level I Analysis

Table 14 lists the potential dollar benefits from process improvements at PBA. An attempt to conservatively quantify these potential economic benefits indicates that a \$28.4 million Net Present Value (1994\$) could be realized by avoiding an otherwise 5 percent escalation in the energy, environmental, and capital spending budget. The 1994 level of spending (Figure 3) is \$17.5 million. An annual 5 percent escalation in

Table 14. Potential dollar benefits from process improvements at Pine Bluff Arsenal.

Process Improvement	Potential	
	K\$/YR	Percent
Reduces energy operating costs	900	30
Reduces environmental operating costs	800	20
Increases productivity	2500	5
Increases ability to meet facility budget targets		
Provides discretionary funds		
Ensures energy and environmental targets are achieved in most effective manner		
Provides competitive edge		

these cost areas will result in \$27.1 million in year 10 (2003). However, by pursuing a formal PEPR program, which could conservatively hold the 1994 spending constant; i.e., \$17.5 million each year for 10 years or \$175 million (current year dollars). This difference (savings), if discounted at 7 percent over the 10-year period, results in \$28.4 million of 1994 Net Present Value. These dollar benefits from aggressively pursuing process improvements by a formal PEPR program are achievable over a phased program with an average payback on investments of less than 2 years. Corollary benefits in labor and raw material use from process improvements could well be three to five times the \$28.4 million contribution from combined energy, environmental, and capital savings.

Preliminary Conclusions

The Level I PEPR review at the Pine Bluff Arsenal met its objective to broadly assess the potential dollar benefits from process improvement in the facilities operations. Results of the Level I review were presented at a management debriefing on 24 June 1994. Analysis of the processes at the WP Fill and L8A3 areas, as well as a review of the central energy systems, identified over 80 ideas that could result in a reduction in energy consumption and a reduction in hazardous wastes and air emissions. Qualitative benefits that would be realized by PBA in implementing projects resulting from these ideas were:

- 45 process improvements identified in the WP plant (Table 11)
- 40 process improvements in the L8A3 Plant (Table 12)
- 34 process improvements in central energy and environmental systems (Tables 6, 7, and 8).

A Level II study would analyze the economics of these potential process improvements. The primary result of this Level I audit was to identify from the many ideas generated the large potential for cost savings at PBA. A preliminary estimate of the overall economic potential is conservatively estimated at 28 million dollars (1994 dollars) over 10 years (Figure 3). This can be achieved only by changes that would be identified and developed in a Level II study.

Some preliminary estimates of possible savings were made in specific areas of the central steam distribution system and the compressed air system. Losses due to leaks and thermal losses in the 34,000 ft of the steam distribution piping represent a significant portion of the energy used to supply steam to the manufacturing end-users. Figure 4 shows an estimate of the steam production and load required by the process and boiler houses. From the data presented in this figure, it is estimated that the

losses during the nonheating season represent approximately 65 percent of the site loads, and on an annual average basis 41 percent of the site load. This effect on cost of steam to the process is shown in Figure 20. It is estimated that the real cost of steam received by the end-user is \$16.78 per 1000 pounds of steam, which provides a significant cost driver for justifying changes to the steam system. Solutions from the "brainstorming" sessions that would allow PBA to downsize and/or decentralize the system to match legitimate process needs include:

1. Decommissioning of idle steam and condensate line segments
2. Use of packaged boilers locally at production areas during the nonheating season
3. Use of cluster production facilities where possible.

A similar assessment for the compressed air system that was completed focused on the use of compressed air at the L8A3 production area. Currently, compressed air is being supplied to the L8A3 area for production purposes. A compressor located in the L8A3 area currently provides breathing air for personnel working in the cubicles where the CH₂Cl₂ is used in the process. Process air from the central system comes to the L8A3 area wet (carrying oil). An oil separator and desiccant are used to dry the air and remove oil. The estimated use of air for process purposes is 20 SCFM. Compressed air losses are estimated at 30 SCFM for drying. Line losses to bring the compressed air to the L8A3 area are estimated at 120 SCFM. Breathing air is estimated at 60 SCFM when three persons have their breathing apparatus attached to the system. Based on the full load amps required by the compressor in the L8A3 area, that compressor has a 50 HP motor. Estimated capacity for the breathing air compressor is 220 SCFM, of which a maximum of 60 SCFM is used for breathing air. The process air requirements of 20 SCFM could easily be added to the breathing compressor and the central compressor could be unloaded by 150 SCFM since the line to the L8A3 area could be decommissioned and the purging of the desiccant bed could be stopped. Assuming a cost of \$0.058/kWh, the result would be an unloading of 33 HP at the central compressors, resulting in a savings of \$11,500 annually for electricity.

The above examples demonstrate the significant energy savings potential available to PBA by initiating a Level II Process Energy and Pollution Reduction study. The current Level I Review identified a large number of specific ideas for process energy and pollution reduction. Quantifying the benefits of these ideas and defining plans for implementation of these ideas would be carried out in the Level II Review.

Note that, while the ideas generated from the Level I review are specific to PBA operations, some of them may apply to other DOD industrial bases with similar operations. The next Chapter discusses how the PEPR analysis tool can help develop a list of ideas for broad application to major energy- and emission-intensive processes.

8 PEPR Analysis Tool Development

A contract was awarded to SAIC to develop the PEPR analysis tool. The following chapter briefly describes what the tool is intended to accomplish. On completion of the contracted work, a technical report will be prepared to: (1) document in detail the selection of major industrial processes, procedures for conducting energy and emissions evaluation, estimations of process energy consumption, and toxic emissions, and (2) to list opportunities for each major process to reduce process energy and pollution.

Overview/Scope

Process Energy and Pollution Reduction (PEPR) involves three levels of procedures: Level I, an analysis based upon a walk through the plant, accounting for perhaps 50 percent of the energy use with no measurements being involved (2 to 15 workdays of effort); Level II, a shortened in-depth analysis of the process, accounting for perhaps 80 percent of the energy use with some measurements being involved (15 to 70 workdays of effort); and Level III, which involves several weeks and 50 to 400 work-days of effort, accounting for 95 percent of the energy use and developing a detailed analyses of energy and pollution reduction measures. It should indeed be possible to automate these procedures to a certain degree via software programming to introduce this methodology into other DOD industrial plants without sponsoring a workshop at every location. A tutorial PEPR software tool can be designed to teach the methodology—together with the PEPR workshop materials—and interest the energy people at DOD facilities in applying PEPR on their own. However, it should be made clear from the beginning what a software approach can and cannot accomplish, particularly at the outset of the development and the use of a software PEPR tool.

At the present time a software tool could be developed for initial screening. This would be the equivalent of an analysis somewhat beyond Level I but perhaps not quite Level II. The tool would initially encompass five “generic” processes selected as being representative and significant in terms of energy and emissions. Such a tool could:

1. Organize the available data
2. Bring to the analysis data from other sources and databases
3. Ask questions to lead the analyst through the methodology like a tutorial

4. Supply default or typical values for missing data
5. Perform the calculations of, for example, specific energy consumption, theoretical energy requirements, process energy efficiency, and pollutants generated.

With a database of available data on the performance and the cost of possible process improvements for typical process unit operations in DOD industrial processes, it should be possible, within the framework of the tool, to develop rough order-of-magnitude analyses of energy and pollution reduction measures for screening, prioritizing, and further analysis.

Basic Structure

Input

The data input for a "run" would be prepared in the form of a "facility file" that would hold all the relevant data for the process energy and emissions analysis for a selected DOD facility. An existing facility file could be chosen, or a new one assembled. For a new file, the facility name would be selected, and general data for that facility would be entered on, for example, applicable environmental regulations, base-wide energy consumption, and emissions data. Such data could be retrieved from three existing databases on environmental regulations (Central Heating Plant Economic Evaluation Program [CHPECON], base-wide energy consumption [DEIS data], and emissions data [NAETS]) via software links, or could be entered manually into the facility file. Data on centralized facilities supplying electricity, steam, hot water, compressed air, chilled water, etc. would also be inserted into the facility file if the data were available. If not, the program would note their absence (and resulting inability to analyze the central facilities) and leave places for later inclusion and file update.

The next task in preparing the facility file would deal with developing the data to describe the industrial processes at the facility being analyzed. Each separate process is thought of as being comprised of a number of discrete unit operations or process steps. The program would contain a database of previously defined unit operations or process steps ("process modules," see Table 15) that would contain a variety of quantitative data on process conditions and charac-

Table 15. Common process steps that could be included in the process module database.

Parts washing
Heat treating
Drying (different types)
Mixing
Painting
Parts forming
Filling
Metal bending
Cleaning (with solvent or water)
Assembling
Conveying
Steaming
Grinding
Heating
Generating inert gas
Packing

teristics, i.e., typical input and output temperatures, pressure, material flows, steam usage, power requirements, emissions, etc. (Table 16) as well as similar data on process alternatives. Initially, the process module database would contain only those process steps comprising the five selected processes.

Each separate process in the facility would be defined as a sequence of identified steps. A user with specific information could edit the data associated with each module in the database or simply accept default values. Provision would be made for the user to define new process modules to describe specific processes. The user-supplied information for the new modules would be inserted into the facility file for the appropriate process. (The new modules would also be inserted into the process module database).

Process Analysis

The next step in the program would be to analyze the processes that have been defined in the facility file. This analysis would be done for the existing "as-is" processes and/or new alternative processes (as selected and controlled by the user via menu options), and would consist of a number of basic calculations. For each process, the total energy requirements (total steam Btus; total compressed air; total electrical power; total air, water, and solid emissions; etc.) would be calculated from the requirements for the individual process steps. For each process, the theoretical energy requirements and theoretical energy efficiencies would be calculated as well. Comparing the actual and theoretical energy efficiencies would highlight those process steps and those processes having the most potential for process energy reduction. Similarly, an analysis of the process emissions would highlight those process operations having the most potential for emissions reduction.

Table 16. Necessary data for each process module.

Process Conditions	Process Characteristics	Process Alternatives*
<ul style="list-style-type: none"> • Pressure • Temperature (of material being worked on, steam usage per unit product, and temperature of supply) • Compressed air usage and pressure of supply • Power required (kW) • Electricity usage (kWh) • Chilled water usage (temperature) • Hot water usage and temperature of supply • Residence time • Air, water emissions (quantity per unit product) • Solid wastes (material, quantity per unit product) 	<ul style="list-style-type: none"> • Material flows (materials, quantity per unit product) • Batch or continuous • Operating hours per year • Operating schedule (day, night, not on weekends, etc.) • Date of installation • Hazards • Variables impacting product quality (especially "bottlenecks") 	<ul style="list-style-type: none"> • Alternative 1 • Alternative 2 • etc.
<p>* New materials, new equipment, changed conditions, new process technology, etc.; quantitative data on each if possible.</p>		

After the "as-is" analysis, the program would then address process alternatives, using available data included in the process modules on the performance and cost of alternative process steps. The data on process alternatives could be categorized as:

1. *Improve existing equipment*—tune-up, make minor modifications, etc.
2. *Select new technologies to do same operations.*
3. *Major process modifications*—change production steps in process, add/delete/combine process steps.

Alternatives in categories 1 and 2 can perhaps be quantified; those in category 3 can be suggested via a question list.

For process alternatives developed by substituting new process steps in place of the old ones (categories 1 and 2), the total energy requirements and the new total (reduced) emissions would be calculated and compared with the existing figures of merit. The substitution of a new process step for an old one could have an impact on other steps. Logic would have to be developed and included in the analysis to estimate the possible interactive effects of such substitution. Life-cycle costs would be calculated for each process alternative.

For process alternatives in the category of major process modifications, the analysis would be nonquantitative and would consist of a description and discussion of options. If the user can define a new alternative process and provide the necessary quantitative data for its analysis, provision could be made for inserting this input into the program and analyzing the new process.

Analysis Logic

As an aid in the analysis of process alternatives, the calculations would be guided by a decision tree to determine which alternative process options should be analyzed and screened. For example, process steps (unit operations) involving the highest energy consumption should perhaps be analyzed first. Process alternatives involving the steps having the most potential for process energy reduction as revealed by a comparison of the actual and theoretical energy efficiencies should be examined. Process alternatives for emissions reduction could be selected for analysis through similar logic. Process steps identified as "bottlenecks" could also be highlighted.

Consideration may be given to developing the logic necessary to determine a hierarchy of potential process alternatives according to criteria defined by the user. Thus, poten-

tial alternatives could be ranked according to energy reduction, emissions reduction, life-cycle cost, etc.

Output

The program would have several types of outputs. First, the program would output the results of the "as-is" process analysis—the total energy requirements and total emissions (broken down by energy and emission type) and energy efficiency (actual and theoretical), broken down by process steps.

Then, for each process alternative analyzed, the output would consist of (1) a description of the alternative and associated costs, (2) the analysis of energy requirements and emissions (like the output for the "as-is" process), (3) a comparison of the alternative and existing processes, e.g., the reductions in energy requirements and emissions, in terms of both the total quantity and the specific quantity (per unit product), and (4) the results of the economic analysis of the process alternative. For process alternatives involving major modifications, the output would consist of a description of the process and a discussion of the energy and emissions reduction potential.

It may also be of interest to aggregate the results for the alternatives for a particular process across all of the DOD facilities analyzed. The program might also include the ability to sum the results over a number of different runs with different facility files. In this case, the output could consist of a total reduction in energy or emissions, at a total cost, achieved by implementing certain alternatives to a specific process at a number of DOD facilities.

Programming Environment

Several possible programming environments may be suitable for developing this software. It could be programmed from scratch in C or PASCAL, or it could be programmed in a database environment. Present plans are to give the overall program the look and feel of the CHPECON or REEP program, which, along with NAETS, were developed using the database software FoxPro. Since it may be desirable to link these databases with the PEPR software, the PEPR program should probably also be programmed in FoxPro.

Future Use of the Program

The PEPR program will be developed initially to analyze five selected processes, so the process module database will be limited to data on the applicable process steps (unit operations) in these selected processes. However, it is anticipated that this program will be applied to other processes in the future. The cumulative future success of this software tool in analyzing DOD industrial processes, and identifying, analyzing, and selecting alternative processes for energy and pollution reduction will depend on the quality and the quantity of site-specific data inserted into the program and the amount of specific information included in the process modules on alternative processes. As the program is used to analyze additional processes, the collected data on existing processes and the results of studies on alternative processes should be used to update the software and its databases. The software should be easy to update, and it should be updated periodically with the results of various users' studies. The file for each DOD facility should be updated periodically, and the software should be used regularly so each facility can access the new information in an updated database.

9 Conclusions and Recommendations

Conclusions

This research developed a strategy to help Army installations cost effectively meet Federal industrial energy efficiency goals and Clean Air Act air toxic emissions reduction goals. The major task of this research was to identify technologies for the DOD industrial base that reduce energy consumption, and reduce air toxic emissions by improving the performance and operation of industrial processes. This project concludes that the DOD can meet these goals through an expansion and coordination of the following ongoing research programs:

1. Modernization of energy production facilities by the Army, Air Force and EPRI
2. Air pollutant emission source inventory surveys by the Army and Navy
3. Industrial energy auditing surveys by the Army
4. The Air toxic emissions source survey developed by Navy and Air Force for the Navy facilities in San Diego, CA
5. Industrial air toxic emissions research by the USEPA's Air and Energy Engineering Research Laboratory.

This project was originally proposed as a 5-year program, but was later modified to a 1-year work unit, even further qualified by the fact that the program review committee did not give permission to submit proposals for subsequent years' funding. Consequently, this study focused its major efforts on defining major industrial processes and developing a Process Energy and Pollution Reduction (PEPR) analysis tool. The research developed a detailed first year project plan to define major industrial processes. An emphasis of the plan is to draw DOD industrial energy and emission data from the Air Pollution Emission System database, now being collected by Army Environmental Center (AEC).

The development of a PEPR screening tool was undertaken to identify energy conservation and emission reduction opportunities for each of the major processes defined. To help in PEPR program development, an energy and emission review was held at Pine Bluff Arsenal, AK. With full cooperation of the base production personnel and energy coordinators, a 1-day workshop was held, followed by a 3-day Level-I energy and emission review. A preliminary report summarizing the results of the

audit was prepared and sent to the Arsenal for review. The base gave the audit a favorable response; a Level II analysis is currently under planning. The PEPR screening program will be beta tested in a DOD industrial facility such as Watervliet Arsenal, NY.

This study concludes that the PEPR analysis tool developed by this research will help installation personnel make informed decisions on whether to modify their production processes or to adopt new technologies to achieve the accelerated energy and environmental goals of the Clean Air Act Amendments and other directives.

Recommendations

It is recommended that:

1. A technical report and user manual be completed to document the development and implementation of the PEPR program.
2. A list of opportunities to reduce process energy and pollution for each of the widely applied DOD industrial processes should be compiled and distributed to base operational staff.
3. The process database for the PEPR program should be expanded to include most of the processes in use at the Defense Department so that the base operation can be thoroughly evaluated. Experiences obtained from previous process audits in the private sector showed that as much as 70 percent reductions in process energy usage was possible. The collateral economic benefits, including reduced environmental pollution, less waste and better quality, often surpass the energy savings.

Because the users of this research project will be a critical part of the research team, this project's proposed implementation plan should transfer into action smoothly. The results of this study will form the basis for modernization plans for industrial facilities, and remediation plans for cleanup of air toxic emission sources. This project will involve both Army installations and various Corps Centers of Expertise. It is recommended that the results be transferred by standard DOD methods such as technical reports, manuals, and notes, which may also be incorporated into training associated with existing energy management programs.

References

- Gard, Inc. *Services to Provide a Report on Process Energy Analysis Parameters*, Technical Report A1-65 (Gard, Inc., Niles, IL, November 1984).
- Lin, M.C.J., R.E. Moshage, G.W. Schanche, C.F. Blazek, R. Biderman, J.A. Kinast, J. Gutraj, D. Conley, and C. Schmidt, *Central Heating Plant Economic Evaluation Program*, Vol 1-5, Technical Report (TR) FE-95/08/ADA293522/ADA293292/ADA294374/ADA293485/ADA293484 (US Army Construction Engineering Research Laboratories [USACERL], January 1995).
- Nemeth, Robert, and D.F. Fournier, "DOD Creates Energy-Modeling Program Using Off-the-Shelf Software" *Energy User News* (May 1994), pp 24-27.
- Procedures for Establishing Emissions for Early Reduction Compliance Extensions, Vol 1, Synthetic Organic Chemical Manufacturing, Ethylene Oxide Sterilization, and Chromium Electroplating*, EPA 450/3-91-012a (U.S. Environmental Protection Agency [USEPA], March 1991), pp 3-5 to 3-7.
- Sliwinski, Benjamin J., *An Estimate of Process Energy Consumption in DARCOM*, TR E-189 (USACERL, October 1983).
- Utech, Daniel M., and T.P. Frazier, *Cost and Benefits of Energy Management Practices of DOD Process Facilities*, IDA Document D-1522 (Office of the Assistant Secretary of Defense [Production and Logistics], August 1994).

Appendix A: Characterization of Potential Metal Air Toxics

by

De Wu

Department of Nuclear Engineering, University of Illinois,
214 NEL, 103 S. Goodwin Ave. Urbana, IL 61801

Introduction

In 1990, the U.S. Federal Government passed the Clean Air Act Amendments (CAAA), one of the country's most significant pieces of legislation on environmental protection. Since the CAAA include many new restrictions under the amendments' various titles, almost every industry will be affected in different ways. For example, new approaches dealing with toxic air substances include the regulation of 189 specific substances, rather than regulating concentrations of the particulate matter with diameters less than 10 μm (PM-10) and a few hazardous pollutants as before. Among the 189 toxic substances, there are 11 high priority metals of concern, including antimony, arsenic, beryllium, cadmium, chromium, cobalt, lead, manganese, mercury, nickel, and selenium.

The toxic metals in air are present in airborne particulate matter, which may come from several types of emission sources, such as traffic, combustion, smelter operation, re-suspended soil, and many others (Buerki, Gaeli, and Nyffeler 1989). Combustion is a major metal emission source. According to the statistics, electric power plants emit half of the total amounts of trace elements by burning fossil fuels (Pacyna 1989). Refuse incineration is another example of toxic metal emission from the combustion since it is a common way to reduce volume of waste and to produce energy. Many studies on metal source appointments and their characterizations have found that municipal waste incineration is one of the important metal emission sources, especially for elements such as Cd, Pb, As and Hg. Studies have also shown that inhalation of the toxic metals could cause lung cancer and other related diseases. One study has even investigated a possible role of cadmium in the progression of HIV and AIDS (*24th Annual Conference* 1990). Controlling metal emissions has become a significant task to keep our environment clean for public safety.

Some environmental research groups have measured the concentrations of these elements in ambient atmosphere. The concentrations of the toxic metals vary with places to places, dependent on the emission sources nearby (Dick 1988; Purghart 1990; Scheff and Valiozis 1990; Kauppinen and Pakkanen 1990). Table A1 shows the typical concentrations of cadmium and lead in a remote, rural, and urban area, and a controlled emission source. As seen, the concentrations of Cd and Pb are several orders of magnitude difference between the locations. Note that the concentrations of Cd and Pb from the source flue are at least two or three orders of magnitude higher than those in a polluted urban area. This suggests that source monitoring and control is an urgent task.

Locating the major sources is the first step in controlling metal emissions. This report gives a detailed result of the literature survey for the sources of these eleven elements originating as air pollutants from industries, and recommends methods of characterization for the sources.

Data Base

This literature search focuses on the possible industrial sources of the eleven elements listed above. The main sources were *Chemical Abstracts (CA)*, and *Engineering Index (EI)*, both well-known abstract data bases. The *Wilson Index*, which includes 1,000 academic, business and popular journals, and the *Current Contents Databases*, which includes 7,000 academic journals over the past 2 years were also used. Both the *Wilson Index* and *Current Contents* cover many fields, such as applied science and technology, engineering, life science, and clinical medical.

Industrial Sources

The U.S. Environmental Protection Agency (USEPA) has listed the possible composition of uncontrolled particulate emissions, including possible major and trace elements in the report "Air Quality Criteria for Particulate Matter and Sulfur Oxides" (1982). Table A2 shows source categories in terms of the eleven hazardous elements.

Table A1. Typical level of Pb and Cd concentrations in several locations.

Element	Concentration			
	Remote Area ⁴ (Antarctica)	Rural Area ⁵ (Switzerland)	Urban Area ⁶ (Athens, Greece)	Source Flue ⁷ (a hospital refuse incinerator)
Pb	5.0 pg/m ³ (1)	1.1 - 382 ng/m ³ (10 ³)	162 - 2273 ng/m ³ (10 ⁵)	190 - 3070 ug/m ³ (10 ⁸)
Cd	0.06 pg/m ³ (1)	0.02 - 2.3 ng/m ³ (10 ³)	0 - 1140 ng/m ³ (10 ⁶)	6 - 28 ug/m ³ (10 ⁸)

Table A2. USEPA source categories of hazardous elements.

Source Category	Major Elements	Trace Elements (< 1% by Weight)	
Fuel combustion (utility, industrial, others)	Coal	—	As, Be, Cd, Co, Cr, Hg, Mn, Ni, Pb, Se
	Oil	—	As, cd, Co, Cr, Hg, Mn, Ni, Pb, Se
Industrial metal processes	Iron and steel	Mn, Pb	As, Cd, Ni, Se
	Primary copper	Pb	As, Cd, Hg, Sb, Se
	Primary lead	Pb	As, Cd, Se
	Primary zinc	Cd, Pb	Hg, Mn
Mineral products	Cement	—	Cd, Cr, Mn, Ni, Se
	Asphalt	—	As, Cr
	Gypsum	—	As, Cd, Cr, Mn, Ni, Pb, Se

Table A3 lists the detailed results of the literature survey of industrial sources of hazardous heavy metals. Basically, the sources include metal-related processes, such as welding, plating, soldering, and polishing. These sources are usually sufficiently strong to adversely affect the health of the workers in the plants, so that many studies have been performed on the medical effects resulting from exposures to these heavy metal air pollutants. Many processes that released metal contaminants to the ambient environment affected the health of people living near the sources, which become a public issue. Arsenic, cadmium, and lead were the metals of most interest in the literatures; beryllium has not been found as an air pollutant.

Table A3. Industrial sources of hazardous heavy metals.

Source	Summary	Hazardous Air Pollutants										Country/Ref.		
		As	Be	Cd	Co	Cr	Hg	Mn	Ni	Pb	Sb		Se	
Foundry	30 manganese-exposed foundry workers were examined, the results indicate that exposure standard of Mn 2.5 mg/m ³ in Sweden (5.0 mg/m ³ in most other country) is too high							X						Sweden/1
Foundry	The blood-lead level in foundry workers was significantly higher than in a control group										X			Poland/2
Automobile manufacture	Air lead exposures and blood lead levels in about 10,000 workers in automobile manufacturing processes measured (paste machine operator in battery plants; solder-grinders in assembly plants; and crane operators in foundries); the average Pb values: 10 µg/m ³ for air and 20 µg/dl for blood, respectively										x			USA/3
Foundry	Blood cadmium levels were determined; the level for steel foundry workers (0.54 µg/100ml) was significantly higher than control group (0.27 µg/100ml)			X										Poland/4
Paint, battery, foundry, steel metal shops	An evaluation of workers handling lead products										X			India/5
Welding shops	Welding aerosols with a high content of F, K, and soluble Mn							X						Russia/6
Welding shops	Determination of trace elements of welding fumes in workroom air	X			X	X		X				X		Canada/7
Permanent magnet production	Assessment of permanent magnet Sm and Co composite dust in working zone air, maximum allowable concentration of Co is 0.05 mg/m ³				X									Russia/8
Ni-Cd and general battery factory	Health examined for 38 workers; Cd in blood is 8-306 µg/l			X						X				Israel/9
Lead acid battery manufacture	Study of lead exposure of battery workers										X			USA/10
Aircraft maintenance facility at Tinker Air Force Base	A program of hazardous waste minimization for plating and surface-finishing			X		X				X				USA/11
A workshop in metallurgical plants	Study of hygienic standard for antimony maximum allowable concentration: 1 mg/m ³											X		China/12

Source	Summary	Hazardous Air Pollutants											Country/Ref.		
		As	Be	Cd	Co	Cr	Hg	Mn	Ni	Pb	Sb	Se			
Impregnated wood in joinery shops	Occupational exposure to wood dust in workroom air which contains Cu, Cr, and AS (CCA); concentration of As ranging from 0.54 to 3.1 $\mu\text{g}/\text{m}^3$	X				X									Sweden/27
Sulfuric acid producing plant	A study of the relation between exposure to As_2O_3 fumes and dust, and the urinary excretion of inorganic arsenic metabolites; the exposure concentrations ranged from 6 to 502 $\mu\text{g}-\text{As}/\text{m}^3$	X													Belgium/28
Glass bangle industry	A study of pulmonary function among worker exposed to multi-metals	X		X	X	X		X		X	X	X			India/29
Chemical plants	Cd and Pb contamination of soil and surface water near a plant producing plastic stabilizing material			X						X					Taiwan/30
Glass factory	Environment agencies target Cr emissions as air pollution					X									USA/31
Rotary cement kilns	The measurement of trace element emission from rotary cement kilns; 0.009 mg/m^3 of Cd and 0.016 mg/m^3 of Pb	X		X						X					Germany/32
Cement factories	Trace elements in dust from cement factories determined by INNA & RNAA	X		X	X	X	X	X		X	X	X			India/33
Power plant	An air emission assessment for benzo(a)pyrene and arsenic	X													USA/34
Highway tunnel exhaust air	Concentration and size distribution of several elements are tested in a highway tunnel							X		X		X			Germany/35
Steel works and non-ferrous plant	Significantly elevated levels were observed for cadmium and lead in the blood of steelworkers and industrial workers exposed to lead- and cadmium containing dusts			X							X				England/36
Plant of ceramic paints	Measurements of 33 trace elements in the hair samples of 48 workers in a manufacturing ceramic paints	X		X	X	X		X		X	X	X			Russia/37
Steel industry	Clean Air Act Amendments of 1990: impact on the steel industry. Cd, Mn, Cr Ni, and Pb are major source of hazardous heavy metals.			X		X		X	X	X					USA/38
Electric steel mills	Electric arc steel mills produce and release some very fine grain size wastes (<10 μm) containing high amount of Pb and Cd into the atmosphere			X							X				Spain/39

Source	Summary	Hazardous Air Pollutants										Country/Ref.		
		As	Be	Cd	Co	Cr	Hg	Mn	Ni	Pb	Sb		Se	
Copper-nickel smelters	A study of environmental impact of heavy metals in freshwater crayfish near copper-nickel smelters is performed; elements such as Cd, Ni and Mn are selected to evaluate the emission source			X				X	X					Canada/53
Copper and nickel smelters	Concentrations of trace metal emissions from two large copper and nickel smelters are measured; environmental impact of the smelters is evaluated			X		X			X	X				Canada/54
Ferro-nickel smelting plant	Seven heavy metals are measured in marine sediments, plants and invertebrates in the vicinity of a ferro-nickel smelting plant				X	X		X	X					Greece/55
Non-ferrous smelters	Characterization of particulate emissions from a zinc, a lead, and a copper smelters								X					USA/56
Secondary lead smelters	Ambient Pb concentrations around three secondary lead smelters are measured; the results show that high Pb emissions from the smelters exceed the provincial guidelines										X			Canada/57
Smelting process	A study of chemical partitioning of cadmium, zinc, lead, and copper in soils near a smelter										X			Japan/58
Primary lead smelters and refineries	Evaluation of the emission control methods for reducing lead levels in ambient air at several smelters										X			USA/59
Copper refining	Removal of trace element antimony from copper smelting process due to environmental concern	X										X		USA/60

Characterization

To control the emissions, one must first characterize the aerosol emissions from pollutant sources and the surrounding atmosphere. Information on the elemental concentrations of emission sources indicates what elements need to be controlled. The particulate size of the elements in fractional concentration is related to the control methods.

The toxicity of the heavy metals depends on the particle sizes, because toxicity is partially related to the particle's ability to penetrate the human lung. A particle with a smaller diameter has a greater potential to penetrate the human lung. This indicates that fine particle emissions require more attention than emissions with coarse

particles. A characterization of aerosols in the atmosphere indicates that the toxic metals, such as As, Cd, and Pb are found mainly in fine particles.

Characterization of the aerosols emitted by a refuse incinerator shows that mass size distribution was bimodal (Kauppinen and Pakkanen 1990). There are two peaks in the distribution, corresponding to the fine and coarse particle groups. Mass medium particle diameters of two peaks are about 0.1 and 6 μm , respectively (Figure A1). The peak of the coarse particle curve is relatively larger than the fine particle curve on mass basis. The elemental size distributions of cadmium and lead are similar to the mass size distribution, but the fine particles had a larger peak than the coarse particles on mass basis (Figure A2). This means that emissions from this source contained preponderantly fine particles of these two elements. This is true for most cases, especially for combustion, due to its effects on particulate formation.

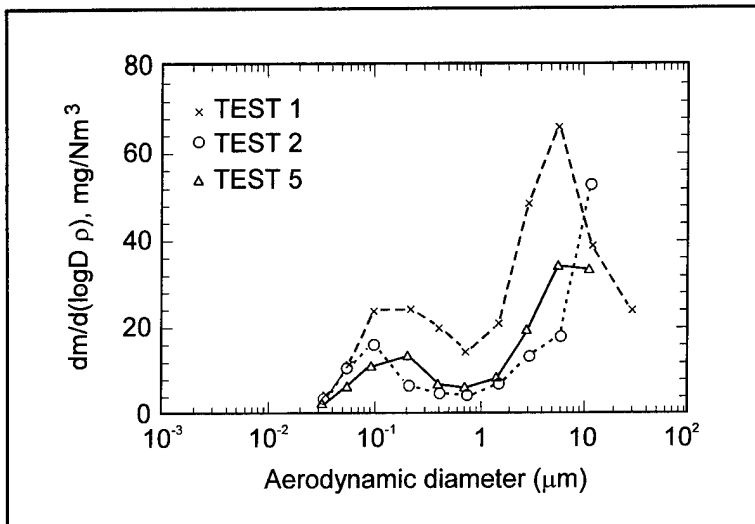

Figure A1. Mass size distribution.

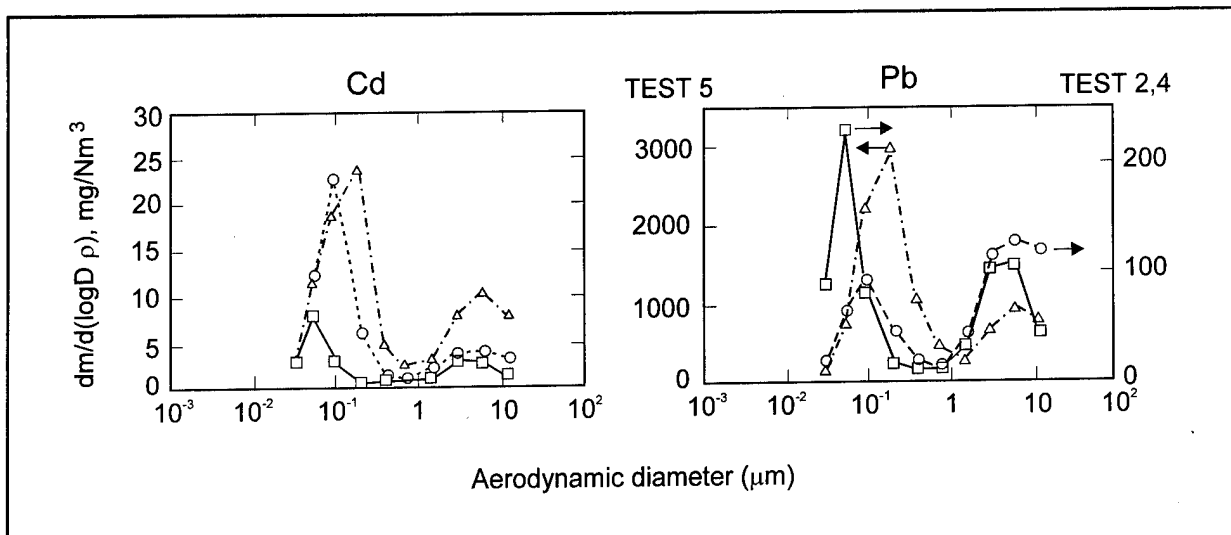

Figure A2. Elemental size distribution.

Sampling

Regular sampling must be done to characterize the particulate from any given sources. A typical collection method is filtration, where a pump is used to pull air (containing particle with the metals) through a filter, so the particulate matter in the air is loaded on the filter.

A cascade impactor is a typical tool for separating particles of different sizes. The numbers of the stages of the cascade impactor used for sampling depend on particle size ranges of interest. A personal sampler, which can be used to collect total particles, is also an easily transported and quiet tool. A large pump with PM-10 sampler is very useful to detect low levels of metal concentrations in ambient air.

Collection efficiency of any filter depends on the filter's pore size and material, and the air flow rate of the pump. Normally, for the same type of filter, a small pore size yields a higher collection efficiency. However, sometimes a filter with small pore size can not be used to collect enough particulate material because it gets plugged. While larger pore size filters may not plug, they are also prone to lose small particles. The filter material should have a minimal metal contamination, and should be suitable for elemental analysis.

Neutron Activation Analysis

Instrumental neutron activation analysis (NAA) is a well-accepted analytical method that avoids time-consuming chemical separation work. More than 40 elements can be analyzed accurately by using different procedures that combine irradiation time, decay time, and counting time. Recent improvement of NAA in the analysis of air filters has been shown using epithermal irradiation and Compton suppression techniques. Typical detection limits for many elements can be as low as a few nanograms (Landsberger and Wu 1993).

The principle of NAA is irradiation of a stable nuclide AZ with neutrons by the ${}^AZ(n,\gamma){}^{A+1}Z$ nuclear reaction. If the product ${}^{A+1}Z$ is a gamma-ray emitter, a gamma-ray detection system can be used to determine both the energy and intensity of the gamma-ray. They can be used to indicate the target nuclide AZ and to find the concentration of the element in the sample, respectively. The analytical sensitivity is mainly dependent on the abundance of the isotope AZ , the neutron capture cross section of AZ , the gamma-ray emission branching ratio of ${}^{A+1}Z$, and the interferences from other gamma-rays in the sample.

Table A4 summarizes the NAA techniques for analyzing eleven elements (Walker, Parrington, and Feiner 1989). Lead and beryllium cannot be analyzed by NAA, although other methods, such as ICP-AA, may be applied.

Recommendation

There are two principal sources of toxic metal emissions: (1) on-site, concentrated sources, and (2) general, dispersive sources. On-site cases are normally related to manufacturing processes. Reducing this type of emission benefits the health of workers. A typical approach to lower such emissions in industry is to install a good ventilation system with particle removal devices. More general sources of toxic metal emission disperse particles into the environment. The concentrations of such pollutants depend on the stability classes of the dispersion at certain places. However, the best approach to the problem is to reduce the emission of particulate material at its source. To do this, the current air pollutants must be accurately measured.

Table A4. Summary of techniques for analyzing the eleven elements.

Element	Nuclear reaction	I_{γ}/σ_{th} ratio	γ -peak used (keV)	Half-life	Method Code*	Comments
Arsenic (As)	$^{75}\text{As}(n,\gamma)^{76}\text{As}$	15.5	559.1	26.3 h	EMC	Good sensitivity
Cadmium (Cd)	$^{114}\text{Cd}(n,\gamma)^{115}\text{Cd}$ $\rightarrow ^{115m}\text{In}$	58.8	336.3	53.5 h	EMC	Decay time must be greater than 33 h
Chromium (Cr)	$^{50}\text{Cr}(n,\gamma)^{51}\text{Cr}$	0.5	320.1	27.7 d	TLC	Good sensitivity
Cobalt (Co)	$^{59}\text{Co}(n,\gamma)^{60}\text{Co}$	2.0	1332.5	5.27 y	TLN	Good sensitivity
Manganese (Mn)	$^{55}\text{Mn}(n,\gamma)^{56}\text{Mn}$	1.0	1810.8	2.56 h	TSN	Good sensitivity
Mercury (Hg)	$^{202}\text{Hg}(n,\gamma)^{203}\text{Hg}$	0.9	279.2	46.6 d	TLC	Interference with Se
Nickel (Ni)	$^{58}\text{Ni}(n,p)^{58}\text{Co}$		810.8	70.9 d	ELC	Sensitivity improved by epithermal irradiation
Antimony (Sb)	$^{121}\text{Sb}(n,\gamma)^{122}\text{Sb}$	33.6	564.1	64.8 h	EMC	Good sensitivity
Selenium (Se)	$^{74}\text{Se}(n,\gamma)^{75}\text{Se}$	12.5	264.7	119.8 d	TLN	400.7 keV low sensitivity, but free of interference

* the 1st letter for the irradiation method: epithermal(E) and thermal(T);
the 2nd letter for the irradiation length: short(S), medium(M) and long(L);
the 3rd letter for the counting method: Compton(C) and normal (N).

References

- Buerki, P.R., B.C. Gaelli, and U.P. Nyffeler, "Size-Resolved Trace Metal Characterization of Aerosols Emitted by Four Important Source Types in Switzerland," *Atmospheric Environment* (1989) vol 23A, No. 8, p 1659.
- Dick, A.L., "Trace Elements in Simultaneously Sampled Aerosol and Snow from the Antarctic Peninsula," *Annual Glaciology* (1988), vol 10, p 201.
- Hemphill, D.H., and R.C. Cothorn, *24th Annual Conference on Trace Substances in Environmental Health and the Annual Meeting of the Society for Environmental Geochemistry and Health (SEGH)* (Cincinnati, OH 9-12 July 1990), p 324.
- Kauppinen, E.I., and T.A. Pakkanen, "Mass and Trace Element Size Distributions of Aerosols Emitted by a Hospital Refuse Incinerator," *Atmospheric Environment* (1990), vol 24A, No. 2, p 423.
- Landsberger, S., and D. Wu, "Improvement of Analytical Sensitivities for the Determination of Sb, As, Cd, In, I, Mo, Si, and U in Airborne Particulate Matter by Epithermal Neutron Activation Analysis," *Journal of Radioanalytical Nuclear Chemistry* (1993), vol 167, p 219.
- Pacyna, J.M., "Technological Parameters Affecting Atmospheric Emissions of Trace Elements From Anthropogenic Sources," in J.M. Pacyna and B. Ottar, eds., *Control and Fate of Atmospheric Trace Metals* (Kluwer Academic Publishers, 1989) , pp 15-31.
- Purghart, B.C.G., U.P. Nyffeler, and P.W. Schindler, "Metals in Airborne Particulate Matter in Rural Switzerland," *Atmospheric Environment* (1990), vol 24A, No. 8, p 2191.
- Scheff, P.A., and C. Valiozis, "Characterization and Source Identification of Respirable Particulate Matter in Athens, Greece," *Atmospheric Environment* (1990), vol 24A, No. 1, p 203.
- Walker, F.W., J.R. Parrington, and F. Feiner, *Nuclides and Isotopes*, 14th ed. (GE Nuclear Energy, San Jose, CA, 1989).

Appendix B: Audit Response From Pine Bluff Arsenal



REPLY TO
ATTENTION OF

SMCPB-EME

DEPARTMENT OF THE ARMY
PINE BLUFF ARSENAL
PINE BLUFF, ARKANSAS 71602-9500



24 AUG 94

MEMORANDUM FOR Commander, US Army Corps of Engineers,
Construction Engineering Research Laboratories,
ATTN: Mrs. Jearldine Northrup,
P.O. Box 9005, Champaign, IL 61826-9005

SUBJECT: Process Energy and Pollution Reduction Audit

1. Pine Bluff Arsenal (PBA) appreciates the effort that you and your audit staff put forth during your auditing and subsequent Process Energy and Pollution Reduction Audit on June 21-24. We were impressed with the expertise and professionalism of the personnel that helped us complete this audit.
2. The techniques demonstrated on our L8A3 and WP process lines were beneficial to environmental, production, and engineering staff and will be used to improve the Arsenal's production capabilities, comply with pollution prevention and other environmental regulations, and reduce energy consumption.
3. The Arsenal is interested in continuing audits of this type on an on-going basis. Any help that CERL can provide to accomplish this task would be appreciated; please contact Mr. Phillip Vick, SMCPB-EME, at DSN 966-2810 or Commercial 501-540-2810 if you can be of any additional service or need any additional information.

FOR THE COMMANDER:

LULA H. DICKSON
Director, Environmental Management

USACERL DISTRIBUTION

Chief of Engineers
 ATTN: CEHEC-IM-LH (2)
 ATTN: CEHEC-IM-LP (2)
 ATTN: CECC-R
 ATTN: CEMP
 ATTN: CEMP-E
 ATTN: CEMP-C
 ATTN: CEMP-M
 ATTN: CERD-C
 ATTN: CERD-ZA
 ATTN: CERD-L
 ATTN: CERD-M
 ATTN: CERM
 ATTN: DAEN-ZC

CECPW 22310-3862
 ATTN: CECPW-E
 ATTN: CECPW-FT
 ATTN: CECPW-ZC

US Army Engr District
 ATTN: Library
 Far East 96205
 Japan 96343
 Walla Walla 99362

FORSCOM 98433
 ATTN: AFZH-DE

US Army Materiel Command (AMC)
 Alexandria, VA 22333-0001
 ATTN: AMCEN-F
 Redstone Arsenal 35898
 ATTN: DESMI-KLF
 Tobyhanna Army Depot 18466
 ATTN: SDSTO-EH
 Radford Army Ammunition Plant
 ATTN: SMCRA-EN 24141
 Aberdeen Proving Ground
 ATTN: STEAP-DEH 21005
 Savannah Army Depot 61074
 ATTN: SDSLE-VAE
 Rock Island Arsenal 61299
 ATTN: Library
 ATTN: AMSMC-EH
 ATTN: SMCRI-TL
 ATTN: US Army Industrial Engineer Activity
 Watervliet Arsenal 12189
 ATTN: SMCWV-EH
 Red River Army Depot 75507
 ATTN: SDSRR-G
 Harry Diamond Lab
 ATTN: Library 20783
 Corpus Christi Army Depot
 ATTN: SDSCC-ECD 78419

Fort Belvoir 22060
 ATTN: Strebe
 ATTN: CETEC-ES 22315-3803

AMMRC 02172
 ATTN: Library
 ATTN: Tech Info Center

CEWES 39180
 ATTN: Library

CECRL 03755
 ATTN: Library

Fort Leonard Wood 65473
 ATTN: ATSE-DAC-LB (3)
 ATTN: ATSE-DAC-LG
 ATTN: ATSE-DAC-FL

US Army ARDEC 07806-5000
 ATTN: SMCAR-AES-P
 ATTN: SMCAR-ISE
 ATTN: Technical Library (2)

Defense Logistics Agency
 ATTN: DLA-WI 22304-6100

Engr Societies Library
 ATTN: Acquisitions 10017

US Military Academy 10996
 ATTN: Geography & Envr Engrg

Naval Facilities Engr Command
 Facilities Engr Command
 ATTN: Code 03 22332-2300 (2)
 Division Offices
 ATTN: Atlantic Division 23511
 ATTN: Western Division 94066
 Naval Facilities Engr Service Center 93043-4328
 ATTN: Bldg 560
 ATTN: Code C35
 ATTN: Public Works Center 92136-5113

Tyndall AFB 32403
 ATTN: HQAFCEA Program Ofc
 ATTN: British Army Staff

US Army Environmental Center 21010
 ATTN: SFIM-AEC-TSD (2)

Production Base Modernization Activity
 ATTN: SMSMC-PBE-C 07806

US Gov't Printing Office 20401
 ATTN: Rec Sec/Deposit Sec (2)

Nat'l Institute of Standards & Tech
 ATTN: Library 20899

Defense Tech Info Center 22060-6218
 ATTN: DTIC-O (2)