

GR

NASA TECHNICAL  
MEMORANDUM

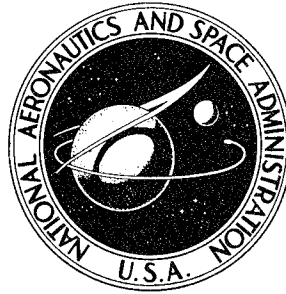

NASA TM X-2852

NASA TM X-2852

APPROVED FOR PUBLICATION  
Agreement to publish in NASA  
Technical Reports

AN EXPERIMENTAL INVESTIGATION  
OF THE DAMPING CONTRIBUTION  
OF AN ELASTOMERIC ABLATOR  
ON ALUMINUM BEAMS

*by William E. Howell*  
*Langley Research Center*  
*Hampton, Va. 23665*

19960313 032

20943



1. Report No. NASA TM X-2852	2. Government Accession No.	3. Recipient's Catalog No.	
4. Title and Subtitle AN EXPERIMENTAL INVESTIGATION OF THE DAMPING CONTRIBUTION OF AN ELASTOMERIC ABLATOR ON ALUMINUM BEAMS		5. Report Date April 1974	6. Performing Organization Code
		8. Performing Organization Report No. L-8713	10. Work Unit No. 502-31-50-01
7. Author(s) William E. Howell	9. Performing Organization Name and Address NASA Langley Research Center Hampton, Va. 23665		11. Contract or Grant No.
12. Sponsoring Agency Name and Address National Aeronautics and Space Administration Washington, D. C. 20546			13. Type of Report and Period Covered Technical Memorandum
		14. Sponsoring Agency Code	
15. Supplementary Notes			
16. Abstract <p>Damping results are presented for an elastomeric ablation material bonded to an aluminum alloy substrate. Tests were conducted on aluminum beams 0.159, 0.318, and 0.476 cm thick, with and without an ablator. Ablation-material thickness varied from 0.159 to 0.953 cm. Comparative damping data were obtained by using variations of the free-free beam technique with strain gages and piezoelectric transducers. Of the two test arrangements employed, the technique using strain gages produced results that indicated less restraint of the beams. Ablation material, in thicknesses less than 1 cm, substantially increased the damping parameter of the aluminum beams.</p>			
17. Key Words (Suggested by Author(s)) Damping Elastomeric ablator Heat shield		18. Distribution Statement Unclassified — Unlimited  STAR Category 18	
19. Security Classif. (of this report) Unclassified	20. Security Classif. (of this page) Unclassified	21. No. of Pages 21	22. Price* \$3.00

\* For sale by the National Technical Information Service, Springfield, Virginia 22151

DAVIDSON

AN EXPERIMENTAL INVESTIGATION OF THE  
DAMPING CONTRIBUTION OF AN ELASTOMERIC ABLATOR  
ON ALUMINUM BEAMS

By William E. Howell  
Langley Research Center

SUMMARY

Damping results are presented for an elastomeric ablation material bonded to an aluminum alloy substrate. Tests were conducted on aluminum beams 0.159, 0.318, and 0.476 cm thick, with and without an ablator. Ablation-material thickness varied from 0.159 to 0.953 cm. Comparative damping data were obtained by using variations of the free-free beam technique with strain gages and piezoelectric transducers. Of the two test arrangements employed, the technique using strain gages produced results that indicated less restraint of the beams. Ablation material, in thicknesses less than 1 cm, substantially increased the damping parameter of the aluminum beams.

INTRODUCTION

A considerable amount of work has been done in developing and testing low-density ablation materials for thermal protection of reentry spacecraft (refs. 1 to 4). The dynamic mechanical response of ablative heat shields of Earth reentry vehicles used to date (Apollo, Gemini, and Mercury) has not been important, since the heat shields were attached directly to small stiff structures. Large lifting-body reentry vehicles such as the space shuttle, however, may use panels of sufficient size to require a better understanding of the damping characteristics of ablative heat-shield materials. In cases where the predicted aeroelastic response of a panel may be near critical, an accurate knowledge of the damping contributed by the ablator may increase the flutter margin sufficiently so that increased panel stiffness, and hence added weight, would be unnecessary.

In investigations of viscoelastic material damping described in the literature, the cantilever beam (refs. 5 and 6) and the free-free beam (ref. 7) methods have been used.

The cantilever beam method has several disadvantages in that a heavy, complex clamping fixture is required to obtain the proper boundary conditions, and metal must be substituted for the elastomer within the clamp. Conversely, the fixture required to suspend the beam in a free-free condition is relatively simple. Therefore, the free-free beam method was chosen for this investigation.

The objectives of this investigation were: (1) to develop a simple experimental apparatus and technique for measuring the fundamental frequency and damping of beams mounted in a free-free condition, (2) to measure the damping of aluminum and aluminum-ablator composites, and (3) to evaluate the contribution of the ablation material to beam damping.

#### SYMBOLS

$A_1$	peak-to-peak oscilloscope trace amplitude, cm
$A_2$	a second peak-to-peak oscilloscope trace amplitude, $A_1/e$ , cm
D	distance between $A_1$ and $A_2$ along the longitudinal axis of the oscilloscope trace, cm
e	base of natural logarithms
F	fundamental frequency, Hz
N	number of cycles of vibration between $A_1$ and $A_2$
S	oscilloscope sweep time, sec/cm

#### TEST SPECIMENS

The dimensions of aluminum alloy (2024-T4) and composite rectangular beams of aluminum and ablator used in this investigation are shown in table I. Both clean aluminum and composite beams of all combinations of aluminum and ablator thicknesses shown in

the table were tested. The ablation material (E4A1) was composed of 75 percent silicone-elastomeric resin, 10 percent phenolic microspheres, 11 percent silica microspheres, and 4 percent silica fibers. It had a nominal density of  $640 \text{ kg/m}^3$ .

After the aluminum beams were tested in the clean configuration, a layer of ablation material 0.953 cm thick was bonded with room-temperature vulcanizing silicone rubber to one side of each beam. A layer of ablation material was removed after each set of tests to obtain the thinner composite beam specimens.

## TEST PROCEDURES

Two types of test techniques were employed. In the first, a small electromagnetic shaker was used to excite the beam and a piezoelectric transducer was used to detect the vibration. The tests employing this technique are referred to herein as "transducer tests." In the second, the beam was excited by striking it near the center and the response was detected through strain gages bonded to the beam. Tests employing this technique are referred to herein as "strain-gage tests."

### Transducer Tests

The beams were supported at the fundamental nodal points by cotton thread. An electromechanical shaker and a piezoelectric transducer were attached to the beam through a small wire bonded to the beam with sealing wax, as shown in figure 1. An audio-oscillator was used to control the shaker. The transducer signal was fed into a frequency counter, an oscilloscope, and an ammeter. The audio-oscillator signal was used to drive the oscilloscope sweep axis. The frequency of the audio-oscillator was varied until a lissajous ellipse was observed on the oscilloscope. The resonant frequency was taken at the point where maximum amplitude response was obtained on the ammeter. The input to the shaker was cut and the oscilloscope trace of the freely damping beam was photographed. Several photographs of the oscilloscope trace were taken for each beam. Measurements were made from enlarged photographs of each trace, and the logarithmic decrement (damping parameter) was calculated.

In this investigation, the individual cycles of vibration were not discernible (fig. 2); therefore, the logarithmic decrement was obtained by the following procedure. First an arbitrary response amplitude  $A_1$  was measured on the photograph. Then this amplitude was divided by the natural-logarithm base  $e$  to obtain a new amplitude  $A_2$ . The

location of  $A_2$  on the oscilloscope trace (damping horn) was marked and the distance between  $A_1$  and  $A_2$  was determined. From these data, the number of cycles of vibration between  $A_1$  and  $A_2$  was calculated by the equation

$$N = FSD$$

The logarithmic decrement is the reciprocal of  $N$ . The average logarithmic decrement value for each beam is listed in table II.

The composite beams were tested in the same manner as the clean beams. The composite beams with an ablation-material thickness of 0.953 cm were tested first. Then the ablation material was machined to a thickness of 0.794 cm and the composite beams were tested again. This procedure was repeated for the other two ablation-material thicknesses listed in table I.

#### Strain-Gage Tests

A pair of semiconductor strain gages forming a half-bridge was bonded to the center of one side of each of the aluminum beams as shown in figure 3. After being mounted in the test fixture and supported at the fundamental nodal points by cotton thread (figs. 3 and 4), the test specimens were excited by an impulse from a solenoid-driven striker. A signal generated by the strain-gage bridge was fed into an oscilloscope and the trace was photographed. Theoretically, the striker impulse will excite all modes of vibration of the beam, but all modes higher than the fundamental damp out in several cycles and the trace then appears to be a smooth, decaying sine wave. Two photographs were required for each data point: one with the oscilloscope sweep time adjusted to display a distinct sine-wave trace for determining the fundamental frequency, and one with a longer oscilloscope sweep time to obtain the damping horn. Several tests were made on each beam, and the average values are listed in table III. The fundamental frequency and logarithmic decrement were calculated by the same method as for the transducer tests.

After the clean aluminum beams were tested, a layer of ablation material 0.953 cm thick was bonded to the clean side of each of the beams. These composite beams were tested and consecutively machined to the ablator thicknesses listed in table I, as described for the transducer tests.

It is shown in reference 8 that a pressure of less than  $1.31 \times 10^{-2}$  atmosphere (1.33 kPa) is required to essentially eliminate aerodynamic damping caused by air pressure drag and viscosity effects. Strain-gage tests were performed at a pressure of  $10^{-3}$  to  $10^{-4}$  atmosphere (100 to 10 Pa) and at 1 atmosphere (100 kPa) to determine the magnitude of aerodynamic damping.

## RESULTS AND DISCUSSION

### Transducer Tests

Average values of the data obtained from the transducer tests are listed in table II. The theoretical fundamental frequencies of the beams were determined by using analytical methods developed in reference 9 and included the effects of transverse shear and rotary inertia. Figure 5 shows a comparison between the theoretical values and the experimental data for the clean aluminum beams and the composite beams with a layer of ablator 0.953 cm thick. The increase in stiffness caused by the attached shaker and transducer probably caused the disparity between the theoretical and experimental frequency values of the clean aluminum beams.

For the composite beams, the theoretical natural frequencies were calculated by using the total mass of the composite beams but neglecting ablator stiffness and the shear and rotary inertia effects of the ablator. Figure 5 shows good agreement for the two thicker composite beams (0.318- and 0.476-cm-thick aluminum) but significant deviation for the thinnest composite beam (0.159-cm-thick aluminum).

Damping data are presented in figure 6, where the logarithmic decrement is plotted as a function of ablation-material thickness. Straight lines have been faired through the data for each of the three aluminum thicknesses. The curves were continued to the data points for the clean beams. The differences between damping values of the composite beams and the clean aluminum beams show the damping contribution of the ablator. The increase in damping of the composite beams over that of the clean aluminum beams was: 8 to 11 times for the 0.159-cm-thick aluminum beams, 5 to 14 times for the 0.318-cm-thick aluminum beams, and 5 to 18 times for the 0.476-cm-thick aluminum beams. The ablator thicknesses used in these tests are, in general, less than actual thickness requirements for heat shields. The linear relationship of the logarithmic decrement to ablator thickness, when plotted on a semilogarithmic scale, should give reasonable estimates of damping for actual heat-shield ablator thicknesses.

## Strain-Gage Tests

Average values of the data obtained from the strain-gage tests are listed in table III. Figure 7 presents a comparison of the theoretical fundamental-frequency values (ref. 9) with the average of the experimental values. For the clean aluminum beams, the two sets of values are in good agreement, indicating that the strain-gage tests more closely approach the ideal free-free beam condition than the transducer tests.

The theoretical fundamental frequencies of the composite beams were calculated by using the mass of the composite beams but neglecting ablator stiffness and the shear and rotary inertia of the ablator. These frequency values were in good agreement for the two thicker sets of composite beams (0.318- and 0.476-cm-thick aluminum). However, for the thinnest set of beams (0.159-cm-thick aluminum) the ablator stiffness, geometry, shear, and rotary inertia effects are probably significant.

Damping data obtained from the strain-gage tests are presented in figure 8. The results parallel those for the transducer tests, although the logarithmic decrement envelope is lower. These data show that the increase in damping of the composite beams was: 1.3 to 18 times for the 0.159-cm-thick aluminum beams, 5 to 21 times for the 0.318-cm-thick aluminum beams, and 4 to 26 times for the 0.476-cm-thick aluminum beams. The largest damping factor obtained in the strain-gage tests was 26. This factor was obtained for the composite beams with a 0.953-cm-thick layer of ablation material. The largest damping factor obtained in the transducer tests was 18. The difference was probably due to the restraint added by the attached transducers in the transducer tests.

The two sets of data presented in figure 8 show the contribution of aerodynamic damping. This contribution was small but discernible for the clean aluminum beams and for the composite beams with the thinnest layer (0.159 cm) of ablation material; however, for the other three sets of composite beams, aerodynamic damping was insignificant.

In order to compare the transducer and strain-gage test techniques, the logarithmic decrements of the clean beams are presented in figure 9. The values obtained in the strain-gage tests were lower than those obtained in the transducer tests by a factor of 2. This result indicates that the clean aluminum beams used in the strain-gage tests were less restrained than those used in the transducer tests.

In figure 10 the experimentally determined fundamental frequencies for the transducer and strain-gage tests are compared with the theoretical values. This comparison also shows that the frequencies obtained in the strain-gage tests agree more closely with

the theoretical frequencies, an indication that the beams in the strain-gage tests were less restrained than those in the transducer tests.

The results obtained in this investigation are for free-free beams and are not directly applicable to panels. Further study is required to determine the damping contribution of an elastomeric ablator on panels. However, an increase in the structural damping coefficient of the magnitude indicated by the results of the present investigation would add appreciable damping to large panels on such vehicles as the space shuttle.

#### CONCLUDING REMARKS

An experimental investigation has been made of the damping contribution of a silicone-elastomeric ablation material bonded to an aluminum substrate. Comparative data were obtained by using variations of the free-free beam technique with strain gages and piezoelectric transducers. Of the two test arrangements employed, the technique using strain gages produced results that indicated less restraint of the beams. Therefore, the strain-gage technique is recommended.

The strain-gage test results showed that the ablation material increased the damping of the aluminum beams by a factor as high as 26. Damping contributions of this magnitude are significant in increasing panel flutter stability.

Langley Research Center,  
National Aeronautics and Space Administration,  
Hampton, Va., December 13, 1973.

## REFERENCES

1. Swann, Robert T.; Brewer, William D.; and Clark, Ronald K.: Effect of Composition, Density, and Environment on the Ablative Performance of Phenolic Nylon. NASA TN D-3908, 1967.
2. Moss, James N.; and Howell, William E.: Recent Developments in Low-Density Ablation Materials. Advances in Structural Composites, SAMPE Vol. 12, Soc. Aerosp. Mater. & Process Eng., c.1967.
3. Strauss, Eric L.: Superlight Ablative Systems for Mars Lander Thermal Protection. J. Spacecraft & Rockets, vol. 4, no. 10, Oct. 1967, pp. 1304-1309.
4. Moss, James N.; and Howell, William E.: A Study of the Performance of Low-Density Phenolic-Nylon Ablators. NASA TN D-5257, 1969.
5. Nashif, Ahid D.: New Method for Determining Damping Properties of Viscoelastic Materials. Shock & Vib. Bull., Bull. 36, Pt. 4, U.S. Dep. Def., Jan. 1967, pp. 37-47.
6. Owens, F. S.: Elastomers for Damping Over Wide Temperature Ranges. Shock & Vib. Bull., Bull. 36, Pt. 4, U.S. Dep. Def., Jan. 1967, pp. 25-35.
7. Ferry, John D.: Viscoelastic Properties of Polymers. Second ed., John Wiley & Sons, Inc., 1970.
8. McWithey, Robert R.; and Hayduk, Robert J.: Damping Characteristics of Built-Up Cantilever Beams in a Vacuum Environment. NASA TN D-3065, 1965.
9. Kruszewski, Edwin T.: Effect of Transverse Shear and Rotary Inertia on the Natural Frequency of a Uniform Beam. NACA TN 1909, 1949.

TABLE I.- NOMINAL SPECIMEN DIMENSIONS

Material	Length, cm	Width, cm	Thickness, cm	Mass, g
Aluminum alloy	15.24	2.54	0.159	17.5
↓	↓	↓	.318	34.6
			.476	51.3
Ablator	15.24	2.54	0.159	3.9
↓	↓	↓	.476	11.6
			.794	19.3
			.953	23.0

TABLE II. - SUMMARY OF RESULTS OF THE PIEZOELECTRIC TRANSDUCER TESTS

Specimen	Aluminum thickness, cm	Ablator thickness, cm	Resonant frequency, <sup>a</sup> Hz	Logarithmic decrement <sup>a</sup>	
1	0.163	0.0	405	$4.93 \times 10^{-3}$	
2		↓	404	$5.54 \times 10^{-3}$	
3		↓	407	$5.72 \times 10^{-3}$	
4		0.159	↓	355	$4.46 \times 10^{-2}$
5			↓	357	$4.93 \times 10^{-2}$
6			↓	354	$5.01 \times 10^{-2}$
7		0.476	↓	318	$4.41 \times 10^{-2}$
8			↓	317	$4.32 \times 10^{-2}$
9			↓	318	$4.36 \times 10^{-2}$
10		0.794	↓	304	$5.53 \times 10^{-2}$
11			↓	307	$5.76 \times 10^{-2}$
12			↓	303	$5.36 \times 10^{-2}$
13		0.953	↓	309	$6.52 \times 10^{-2}$
14			↓	309	$6.41 \times 10^{-2}$
15			↓	300	$5.73 \times 10^{-2}$
16	0.323	0.0	739	$1.48 \times 10^{-3}$	
17		↓	739	$1.35 \times 10^{-3}$	
18		↓	737	$1.35 \times 10^{-3}$	
19		0.159	↓	673	$5.95 \times 10^{-3}$
20			↓	673	$6.60 \times 10^{-3}$
21			↓	673	$6.82 \times 10^{-3}$
22		0.476	↓	622	$9.71 \times 10^{-3}$
23			↓	622	$9.85 \times 10^{-3}$
24			↓	622	$9.19 \times 10^{-3}$
25		0.794	↓	585	$1.65 \times 10^{-2}$
26			↓	586	$1.62 \times 10^{-2}$
27			↓	585	$1.59 \times 10^{-2}$
28		0.953	↓	571	$1.88 \times 10^{-2}$
29			↓	570	$1.95 \times 10^{-2}$
30			↓	571	$1.86 \times 10^{-2}$
31	0.475	0.0	1077	$5.04 \times 10^{-4}$	
32		0.159	1011	$2.77 \times 10^{-3}$	
33		.159	1011	$1.89 \times 10^{-3}$	
34		0.476	952	$3.13 \times 10^{-3}$	
35		.476	952	$3.67 \times 10^{-3}$	
36		0.794	901	$6.85 \times 10^{-3}$	
37		.794	901	$7.72 \times 10^{-3}$	
38		0.953	879	$8.93 \times 10^{-3}$	
39		.953	877	$9.46 \times 10^{-3}$	

<sup>a</sup> Each resonant frequency and logarithmic decrement is an average of approximately three test values.

TABLE III. - SUMMARY OF RESULTS OF THE STRAIN-GAGE TESTS

Specimen	Aluminum thickness, cm	Ablator thickness, cm	Resonant frequency, <sup>a</sup> Hz	Logarithmic decrement <sup>a</sup>	Pressure, atm <sup>b</sup>	
40	0.162 ↓	0.0	369	$2.72 \times 10^{-3}$	1.0	
		.0	369	$2.40 \times 10^{-3}$	$3.0 \times 10^{-4}$	
41		0.159	326	$3.49 \times 10^{-3}$	1.0	
		.159	326	$3.26 \times 10^{-3}$	$2.6 \times 10^{-4}$	
42		0.476	294	$1.74 \times 10^{-2}$	1.0	
		.476	294	$1.72 \times 10^{-2}$	$1.3 \times 10^{-4}$	
43		0.794	286	$4.70 \times 10^{-2}$	1.0	
		.794	287	$4.47 \times 10^{-2}$	$3.7 \times 10^{-4}$	
44		0.953	292	$6.59 \times 10^{-2}$	1.0	
		.953	294	$6.19 \times 10^{-2}$	$1.3 \times 10^{-4}$	
45		0.314 ↓	0.0	713	$7.98 \times 10^{-4}$	1.0
46			↓	719	$6.71 \times 10^{-4}$	$5.6 \times 10^{-4}$
				719	$7.73 \times 10^{-4}$	1.0
				719	$6.96 \times 10^{-4}$	$5.3 \times 10^{-4}$
47	0.159		671	$1.37 \times 10^{-3}$	1.0	
	↓		672	$1.28 \times 10^{-3}$	$2.6 \times 10^{-4}$	
664			$5.69 \times 10^{-3}$	1.0		
663			$5.44 \times 10^{-3}$	$3.9 \times 10^{-4}$		
49	0.476		613	$4.87 \times 10^{-3}$	1.0	
	↓		613	$4.75 \times 10^{-3}$	$2.6 \times 10^{-4}$	
614			$5.34 \times 10^{-3}$	1.0		
614			$5.34 \times 10^{-3}$	$2.6 \times 10^{-4}$		
51	0.794		573	$9.68 \times 10^{-3}$	1.0	
	↓		575	$9.46 \times 10^{-3}$	$5.1 \times 10^{-4}$	
575		$1.04 \times 10^{-2}$	1.0			
575		$1.02 \times 10^{-2}$	$5.4 \times 10^{-4}$			
563		$1.34 \times 10^{-2}$	1.0			
53	0.953	563	$1.32 \times 10^{-2}$	$3.6 \times 10^{-4}$		
	↓	556	$1.76 \times 10^{-2}$	1.0		
556		$1.64 \times 10^{-2}$	$4.3 \times 10^{-4}$			
556		$1.64 \times 10^{-2}$	$4.3 \times 10^{-4}$			
55	0.470 ↓	0.0	1063	$2.96 \times 10^{-4}$	1.0	
56		↓	1063	$3.19 \times 10^{-4}$	1.0	
			1063	$2.62 \times 10^{-4}$	$5.6 \times 10^{-4}$	
			1016	$1.14 \times 10^{-3}$	1.0	
57		0.159	1016	$1.14 \times 10^{-3}$	1.0	
		↓	1016	$8.56 \times 10^{-4}$	$1.3 \times 10^{-4}$	
1004			$8.78 \times 10^{-4}$	1.0		
1005			$7.74 \times 10^{-4}$	$2.6 \times 10^{-4}$		
59		0.476	956	$2.24 \times 10^{-3}$	1.0	
		↓	957	$2.21 \times 10^{-3}$	$1.3 \times 10^{-4}$	
953			$1.91 \times 10^{-3}$	1.0		
953			$1.88 \times 10^{-3}$	$1.3 \times 10^{-4}$		
61		0.794	904	$5.02 \times 10^{-3}$	1.0	
		↓	904	$5.08 \times 10^{-3}$	$7.9 \times 10^{-4}$	
899	$4.84 \times 10^{-3}$		1.0			
899	$4.79 \times 10^{-3}$		$5.7 \times 10^{-4}$			
63	0.953	875	$6.53 \times 10^{-3}$	1.0		
	↓	875	$6.83 \times 10^{-3}$	$2.0 \times 10^{-4}$		
875		$6.63 \times 10^{-3}$	1.0			
875		$6.53 \times 10^{-3}$	$2.6 \times 10^{-4}$			

<sup>a</sup> Each resonant frequency and logarithmic decrement is an average of approximately three test values.

<sup>b</sup> 1 atm = 100 kPa.

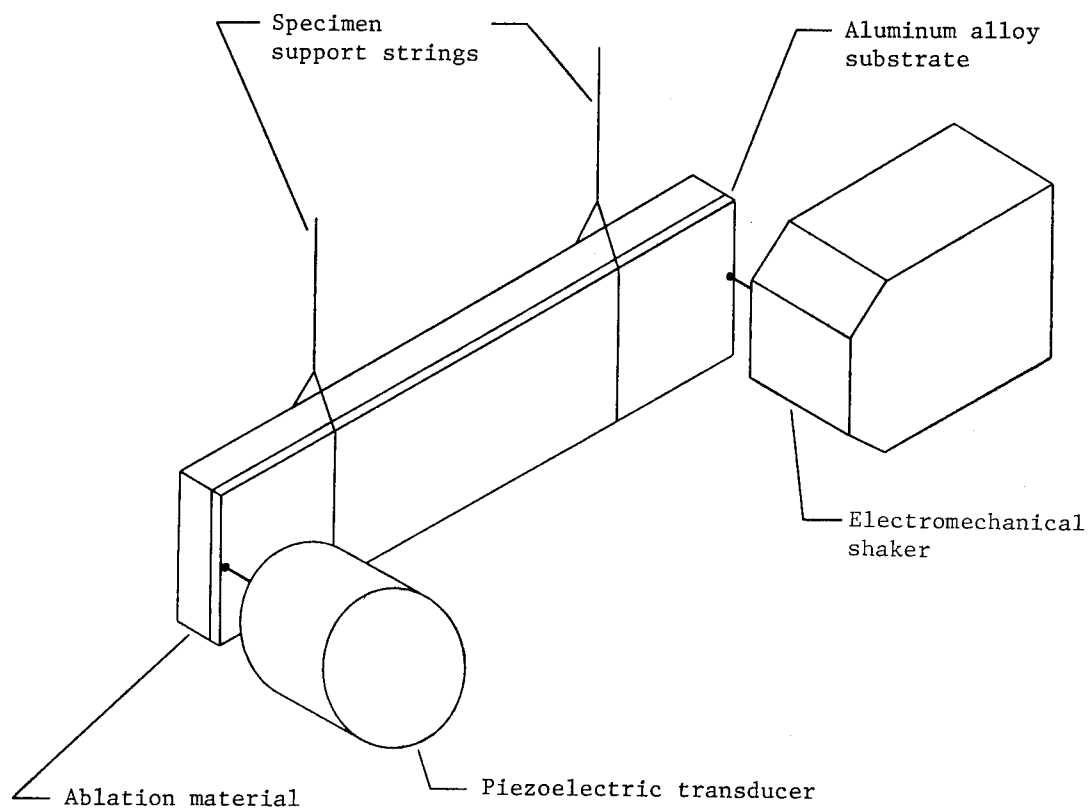
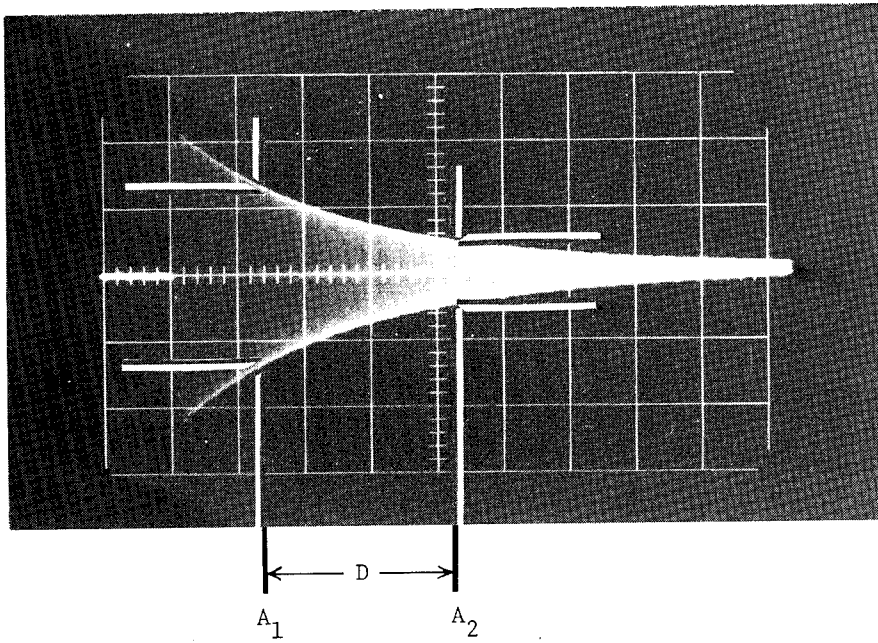

Figure 1.- Specimen-mounting configuration and instrumentation for the piezoelectric transducer tests.



$A_1$  = amplitude  
 $A_2 = A_1/e$   
 $D$  = Distance, cm

L-73-8045

Figure 2.- Composite-beam damping trace showing how  $D$  is determined.

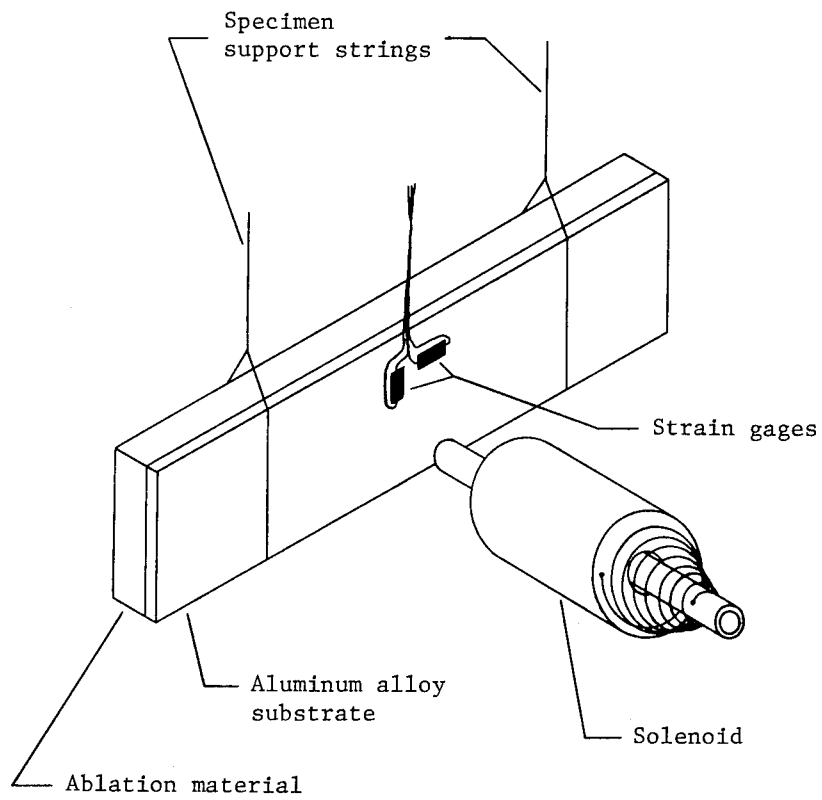
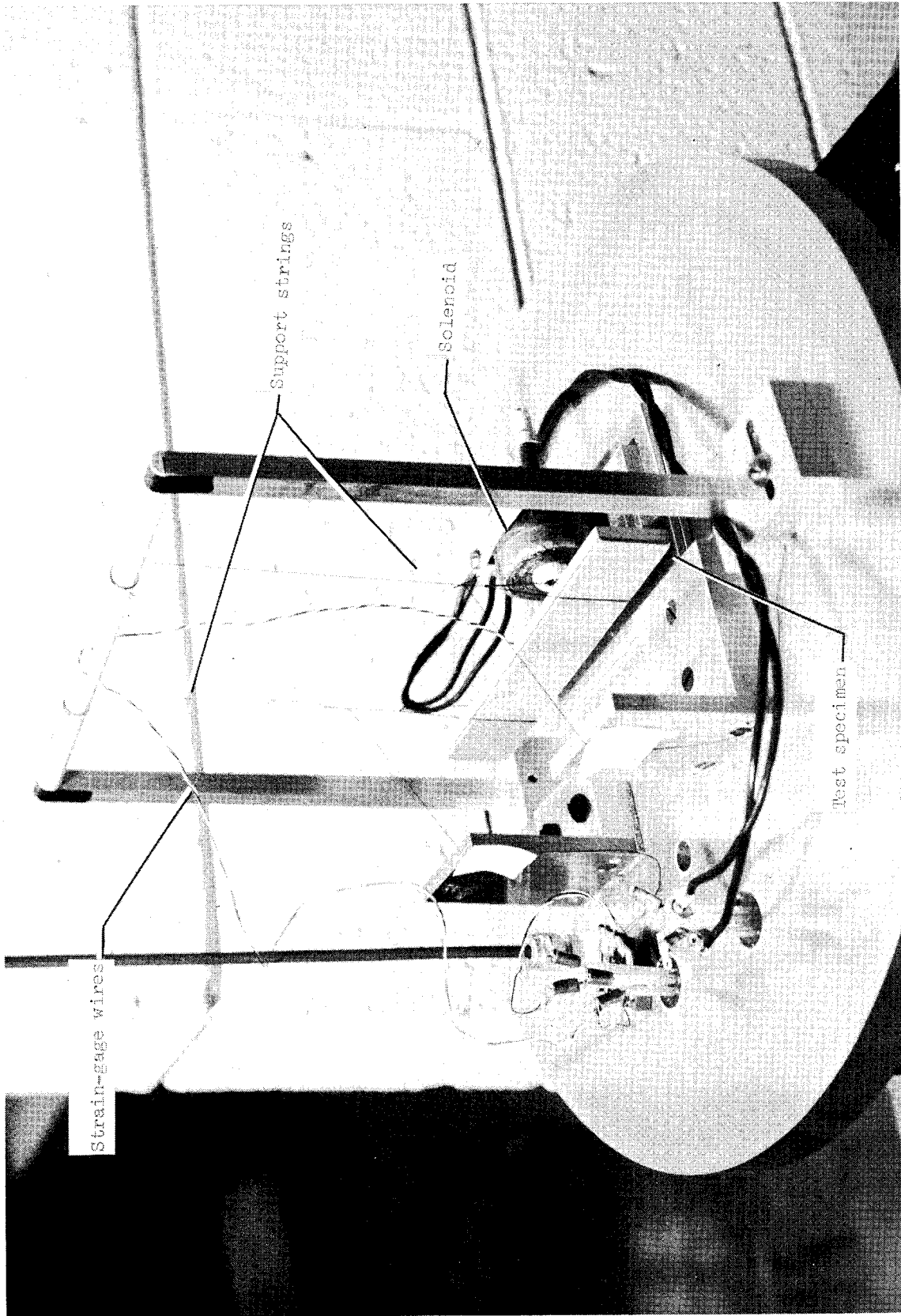

Figure 3.- Specimen-mounting configuration and instrumentation for the strain-gage tests.



L-70-8628.1

Figure 4.- Specimen-mounting configuration for the strain-gage tests.

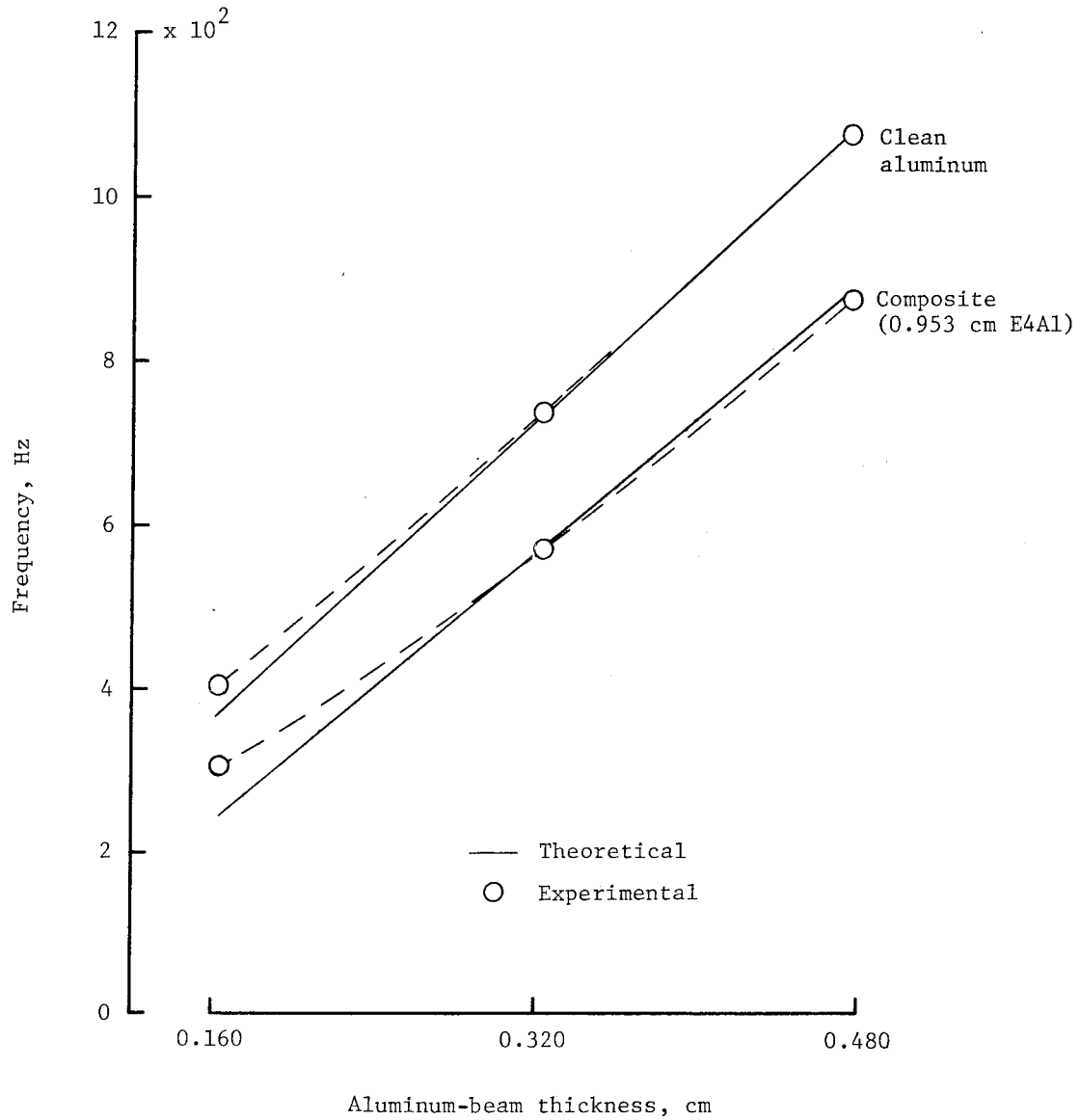

Figure 5.- A comparison of the theoretical and experimentally determined fundamental frequencies for the transducer tests.

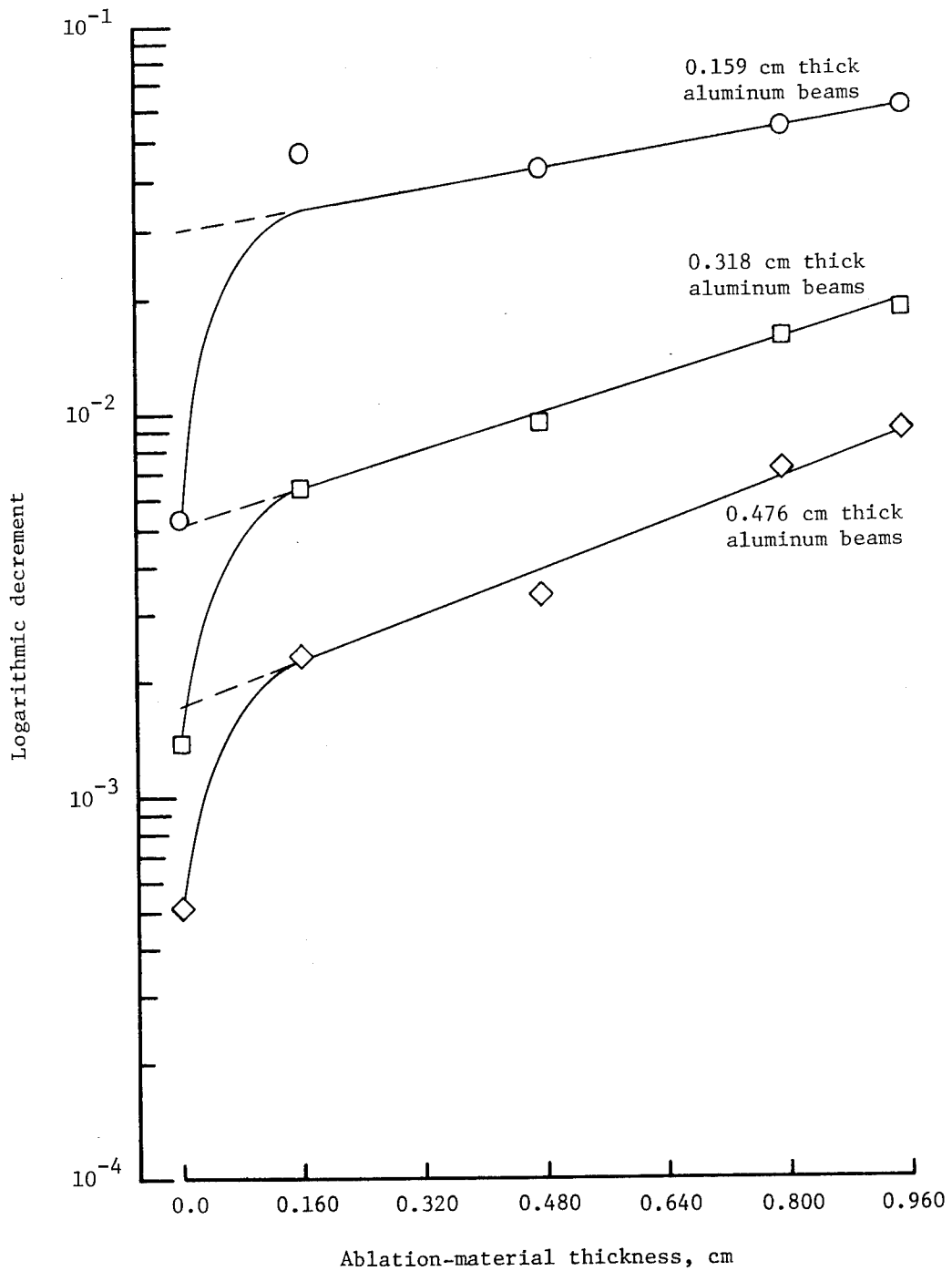

Figure 6.- Effect of an ablation material on the damping characteristics of aluminum beams for the transducer tests.

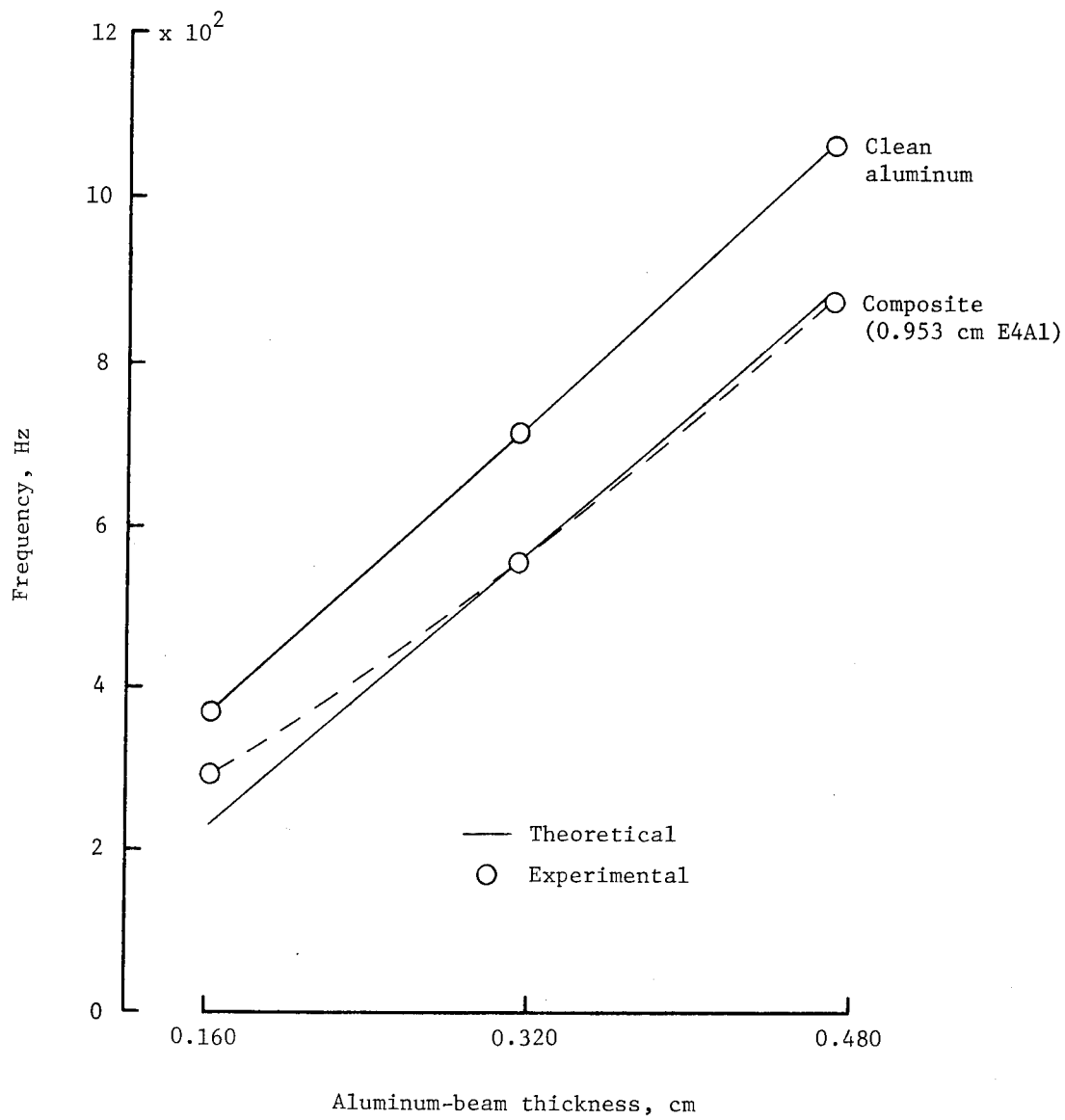

Figure 7.- A comparison of the theoretical and experimentally determined fundamental frequencies for the strain-gage tests.

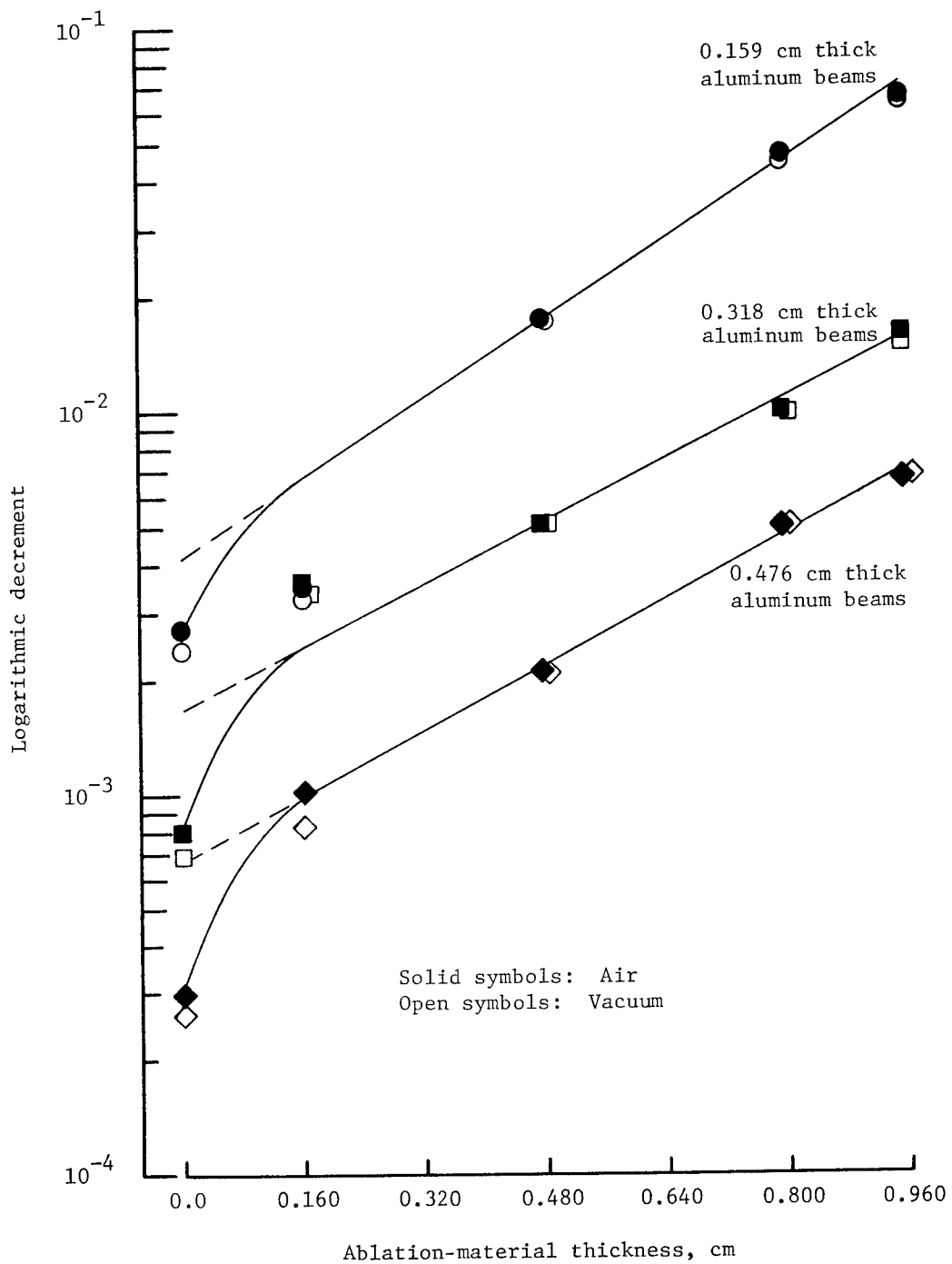

Figure 8.- Effect of ablation material on the damping characteristics of aluminum beams for the strain-gage tests.

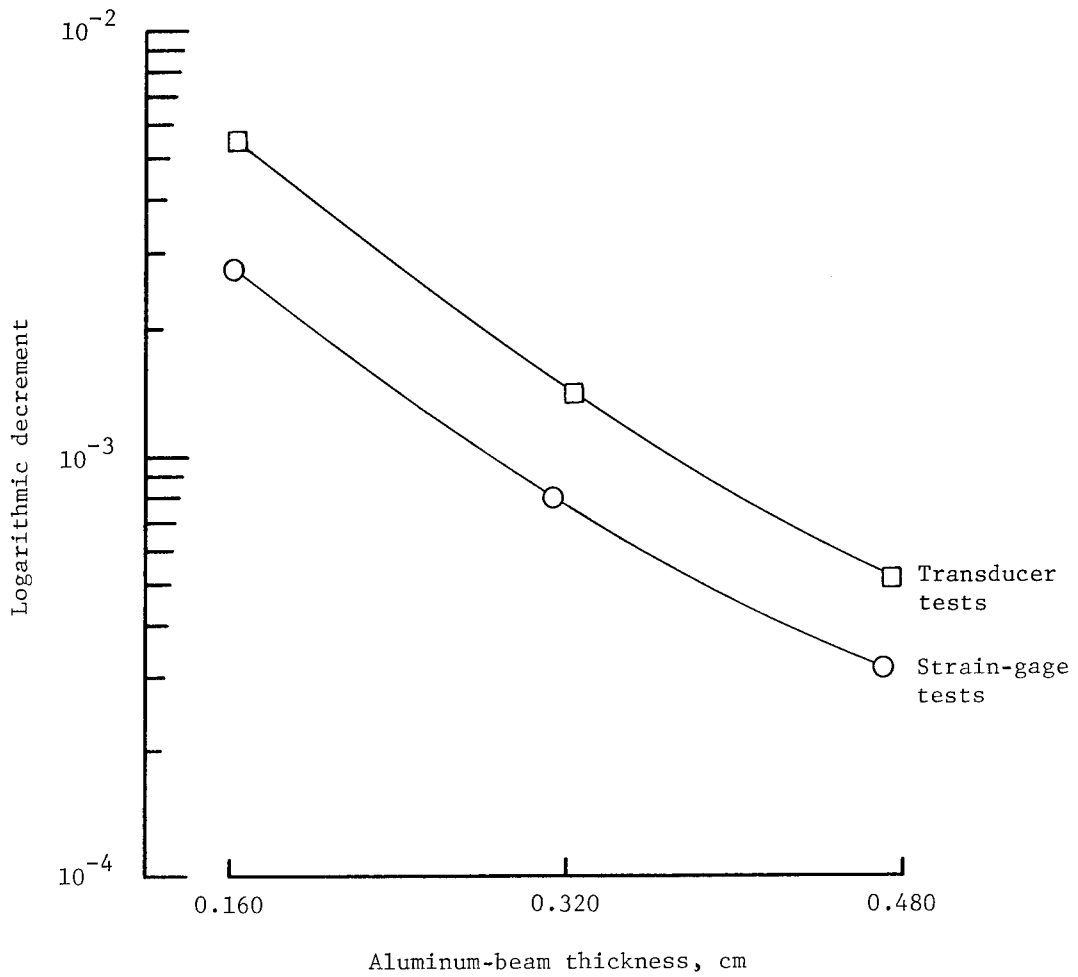

Figure 9.- A comparison of the logarithmic decrement of the aluminum beams for the transducer and strain-gage tests.

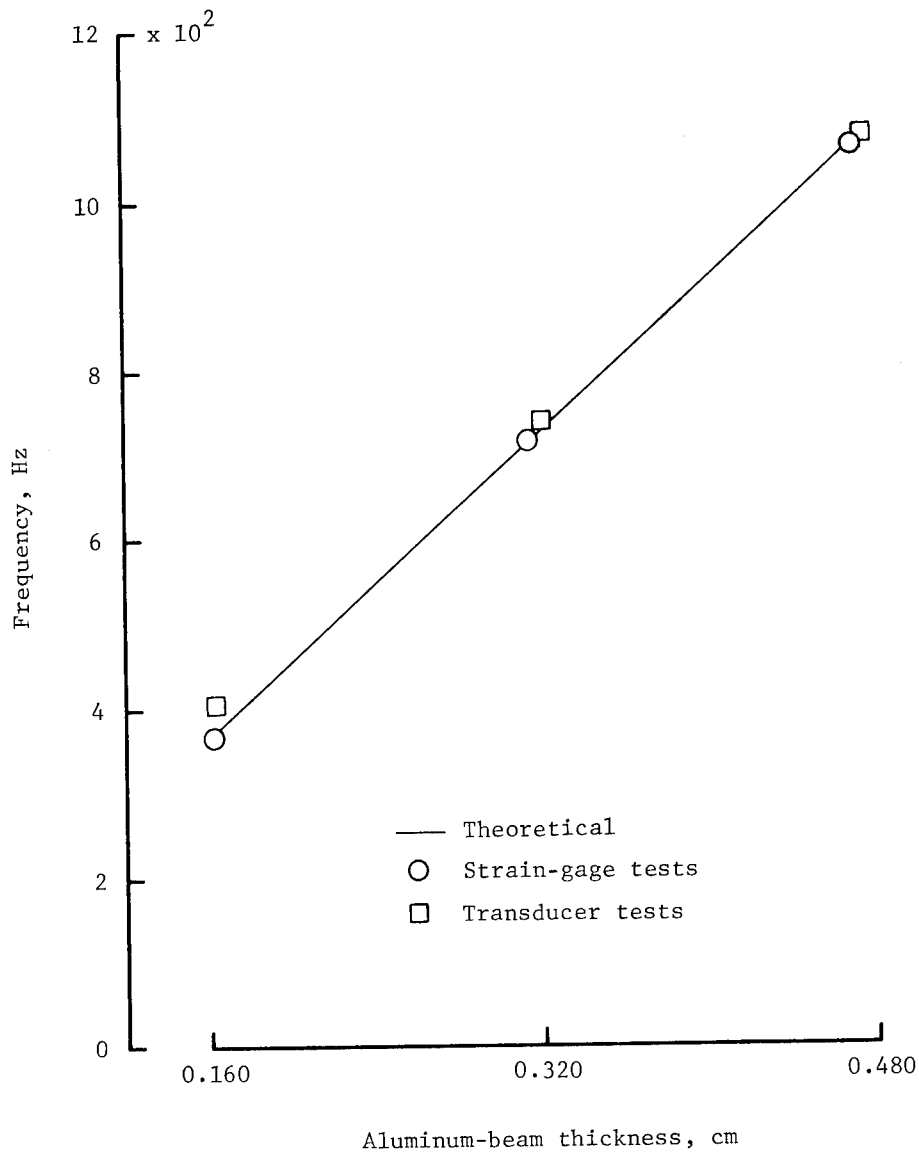

Figure 10.- A comparison of the experimentally determined fundamental frequencies for the transducer and strain-gage tests.

NATIONAL AERONAUTICS AND SPACE ADMINISTRATION  
WASHINGTON, D.C. 20546

OFFICIAL BUSINESS  
PENALTY FOR PRIVATE USE \$300

SPECIAL FOURTH-CLASS RATE  
BOOK

POSTAGE AND FEES PAID  
NATIONAL AERONAUTICS AND  
SPACE ADMINISTRATION  
451



215 001 01 U 18 740315 S00942DS  
DEPT OF THE ARMY  
PICATINNY ARSENAL  
PLASTICS TECHNICAL EVALUATION CENTER  
ATTN: SMUPA-VP3  
DOVER NJ 07801

POSTMASTER :

If Undeliverable (Section 158  
Postal Manual) Do Not Return

*"The aeronautical and space activities of the United States shall be conducted so as to contribute . . . to the expansion of human knowledge of phenomena in the atmosphere and space. The Administration shall provide for the widest practicable and appropriate dissemination of information concerning its activities and the results thereof."*

—NATIONAL AERONAUTICS AND SPACE ACT OF 1958

## NASA SCIENTIFIC AND TECHNICAL PUBLICATIONS

**TECHNICAL REPORTS:** Scientific and technical information considered important, complete, and a lasting contribution to existing knowledge.

**TECHNICAL NOTES:** Information less broad in scope but nevertheless of importance as a contribution to existing knowledge.

**TECHNICAL MEMORANDUMS:** Information receiving limited distribution because of preliminary data, security classification, or other reasons. Also includes conference proceedings with either limited or unlimited distribution.

**CONTRACTOR REPORTS:** Scientific and technical information generated under a NASA contract or grant and considered an important contribution to existing knowledge.

**TECHNICAL TRANSLATIONS:** Information published in a foreign language considered to merit NASA distribution in English.

**SPECIAL PUBLICATIONS:** Information derived from or of value to NASA activities. Publications include final reports of major projects, monographs, data compilations, handbooks, sourcebooks, and special bibliographies.

**TECHNOLOGY UTILIZATION PUBLICATIONS:** Information on technology used by NASA that may be of particular interest in commercial and other non-aerospace applications. Publications include Tech Briefs, Technology Utilization Reports and Technology Surveys.

*Details on the availability of these publications may be obtained from:*

**SCIENTIFIC AND TECHNICAL INFORMATION OFFICE**

**NATIONAL AERONAUTICS AND SPACE ADMINISTRATION**

Washington, D.C. 20546